



<p>© ELECTROLUX HOME PRODUCTS ITALY S.p.A. Spares Operations Italy Corso Lino Zanussi, 30 I - 33080 PORCIA /PN</p> <p>Fax +39 0434 394096</p> <p>Edition: 2007-10-10</p>	<p><b>Washing machines with electronic control system</b></p> <p><b>EWM3500</b></p> <p><b>Technical and functional characteristics</b></p> <p><b>ENV06</b></p> <p><b>Styling AEG</b></p> <p><b>SERIES 8</b></p>	



# CONTENT

1	Purpose of this manual .....	4
2	PRECAUTIONS .....	4
3	SERIES 8 .....	5
3.1	GENERAL CHARACTERISTICS .....	5
3.2	CONTROL PANEL .....	6
3.2.1	Styling SERIES 8 .....	6
3.3	Configuration of control panel .....	7
3.3.1	Programme selector (S1) .....	7
3.3.2	Programme configuration .....	7
3.3.3	LCD and buttons .....	8
4	DEMO .....	14
5	DIAGNOSTIC SYSTEM .....	15
5.1	Access to diagnostics mode .....	15
5.2	Exiting diagnostics mode .....	15
5.3	Diagnostics phases .....	16
5.3.1	Analysis of the LCD display during the diagnostic cycle .....	17
6	ALARMS .....	18
6.1	Displaying the alarms to the user .....	18
6.2	Reading the alarm codes .....	19
6.2.1	Displaying the alarm .....	20
6.2.2	Examples of alarm display .....	20
6.2.3	Operation of alarms during diagnostics .....	20
6.3	Rapid reading of alarm codes .....	21
6.4	Cancelling the last alarm .....	21
6.5	Cancelling the memories .....	22
7	OPERATING TIME COUNTER .....	22
8	WASHING PROGRAMMES AND OPTIONS .....	23
8.1	Programmes .....	23
8.2	Options .....	24
8.2.1	Compatibility between Options .....	26
8.3	Descriptions of the options .....	27
9	TECHNICAL CHARACTERISTICS .....	29
9.1	Control system memory .....	29
9.1.1	General structure of the memory system .....	29
9.1.2	FLASH .....	29
9.1.3	RAM .....	30
9.2	Door interlock .....	31
9.2.1	Voltmetric interlock with PTC .....	31
9.2.1.1	Operating principle .....	31
9.2.2	Instantaneous door interlock .....	32
9.2.2.1	Operating principle .....	32
9.2.2.2	Conditions required for opening the door .....	32
9.2.2.3	Automatic unlock .....	32
9.3	Water fill system .....	33
9.4	Analogue pressure switch of water level control in the tub .....	33
9.5	Drain pump .....	34
9.6	Recirculation pump (if featured) .....	34
9.7	Heating .....	35
9.8	Temperature sensor .....	35
9.9	Three-phase asynchronous motor .....	36
9.9.1	Power supply to motor .....	36
9.10	Anti-foam control system .....	37
9.11	FUCS ( Fast Unbalance Control System) .....	38
10	Table of alarm codes of the main PCB .....	40
11	Diagram with THREE-PHASE ASYNCHRONOUS MOTOR .....	44
12	ACCESSIBILITY TO THE ELECTRONIC CONTROL SYSTEM .....	46
12.1.1	Work top .....	46
12.1.2	Control panel .....	46

# 1 Purpose of this manual

The purpose of this manual is to provide service engineers who are already familiar with the repair procedures for traditional washing machines with information regarding appliances fitted with the ENV06 electronic control system and produced in Porcia (Italy) and Olawa (Poland).

The characteristic of the ENV06 electronic control system is to use only an electronic pressure switch to check the various water levels in the tub (with the elimination of the mechanical pressure switches: anti-overflow, anti-boiling, 1st-2nd level), and a new heater with two thermal fuses which interrupt if the temperature degree overcomes the values by which they are calibrated.

The following are described:

- general characteristics
- control panel and washing programmes
- technical and functional characteristics
- access to the electronic control system

For detailed information concerning hydraulic circuit, structural characteristics of the appliances and accessibility, please refer to Service Manual:

- *Publication no. 599 37 67-82 – washing machines with HEC-ARCHED cabinet.*

## 2 PRECAUTIONS



- **Electrical appliances must be serviced only by qualified Service Engineers.**
- **Always remove the plug from the power socket before touching internal components.**
- **In case of replacement of the heater, replace it with one with the same characteristics in order not to compromise the safety of the appliance.**

### 3 SERIES 8

#### 3.1 GENERAL CHARACTERISTICS

The ENV060 electronic control system consists of two electronic boards. One integrates the power and control functions and the selector, the other the display function, where also the LCD display is connected.

The PCB is mounted on a casing fitted to the control panel.



<p><b>Version</b></p> <p style="text-align: center;"><b>SERIES 8</b></p>	
<p><b>Number of buttons</b></p>	<ul style="list-style-type: none"> <li>▪ Max. 7 (1 options + start/pause)</li> </ul>
<p><b>Number of LEDs</b></p>	<ul style="list-style-type: none"> <li>▪ Max. 2 + LCD</li> </ul>
<p><b>Programme selector</b></p>	<ul style="list-style-type: none"> <li>▪ 21 positions with main switch (incorporated in the PCB )</li> </ul>
<p><b>Serial port</b></p>	<ul style="list-style-type: none"> <li>▪ DAAS-EAP communications protocol up to 115.200 baud</li> </ul>
<p><b>Power supply</b></p>	<ul style="list-style-type: none"> <li>▪ 220/240V</li> <li>▪ 50/60 Hz (configurable)</li> </ul>
<p><b>Type of washing</b></p>	<ul style="list-style-type: none"> <li>▪ Jet-system</li> </ul>
<p><b>Rinsing system</b></p>	<ul style="list-style-type: none"> <li>▪ Jet-system</li> </ul>
<p><b>Motor</b></p>	<ul style="list-style-type: none"> <li>▪ Two-pole asynchronous, with three-phase tachometric generator (with Inverter)</li> </ul>
<p><b>Spin speed</b></p>	<ul style="list-style-type: none"> <li>▪ 1200 ÷ 1600 rpm</li> </ul>
<p><b>Anti-unbalancing system</b></p>	<ul style="list-style-type: none"> <li>▪ FUCS</li> </ul>
<p><b>Water fill</b></p>	<ul style="list-style-type: none"> <li>▪ 1 solenoid valve with 1 inlet – 2/3 outlets</li> </ul>
<p><b>Detergent drawer</b></p>	<ul style="list-style-type: none"> <li>▪ 4 compartments: prewash, wash, conditioners, (stains)</li> </ul>
<p><b>Control of water level in the tub</b></p>	<ul style="list-style-type: none"> <li>▪ Electronic/analogue pressure switch</li> </ul>
<p><b>Door safety device</b></p>	<ul style="list-style-type: none"> <li>▪ Traditional (with PTC)</li> <li>▪ Instantaneous</li> </ul>
<p><b>Power of heating element</b></p>	<ul style="list-style-type: none"> <li>▪ 1950W with thermal fuses incorporated</li> </ul>
<p><b>Temperature control</b></p>	<ul style="list-style-type: none"> <li>▪ NTC sensor incorporated in the heater</li> </ul>
<p><b>Buzzer</b></p>	<ul style="list-style-type: none"> <li>▪ Traditional incorporated in the electronic board</li> </ul>
<p><b>Sensors</b></p>	<ul style="list-style-type: none"> <li>▪ Water fill gauge (flowmeter)</li> <li>▪ Aqua control</li> </ul>

## 3.2 CONTROL PANEL

### 3.2.1 Styling SERIES 8

- max. 7 buttons
- 21-position programme selector
- LEDs 2
- LCD

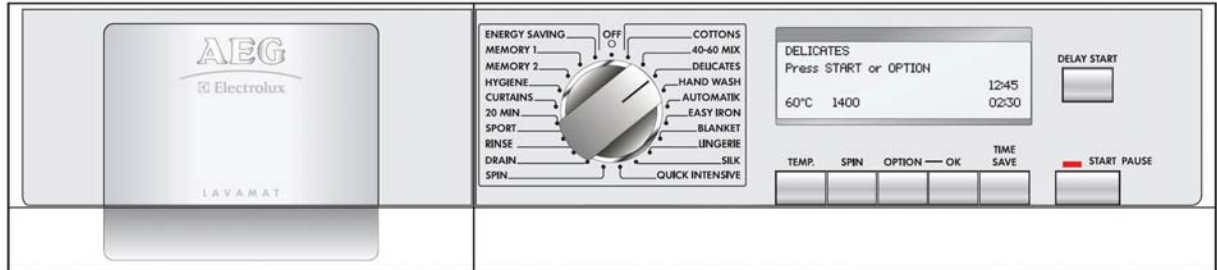

- Disposition of LEDs and buttons

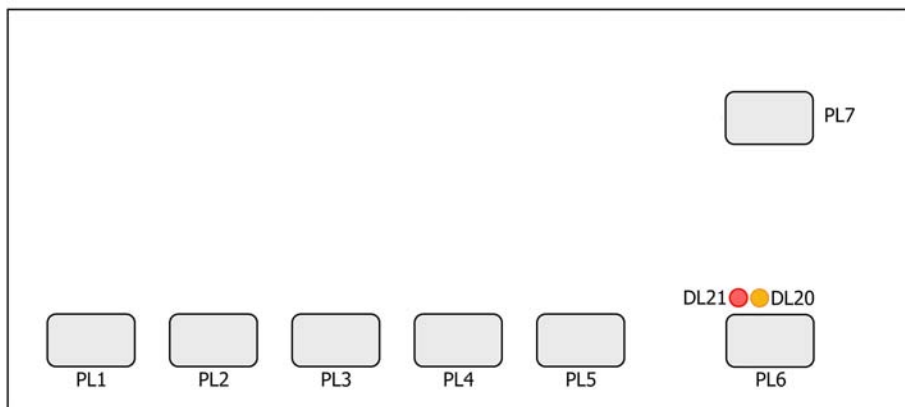

### 3.3 Configuration of control panel

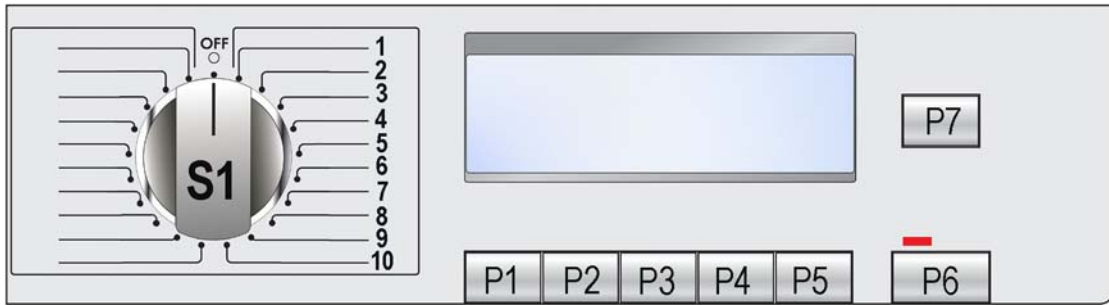

**The washing programmes, the functions of the selector knob and the various pushbuttons vary according to the model, since these are determined by the configuration of the appliance.**

#### 3.3.1 Programme selector (S1)

The selector features 21 positions and incorporates the ON/OFF switch. The various positions of the selector may be configured to perform different washing programmes (ex: water level, drum movement, no. of rinses and the washing temperature to be selected according to the type of clothes). It can be turned both clockwise and anti-clockwise.

In the first position, the appliance is switched off and the current programme is cancelled.

If during the execution of a washing programme, the programme selector knob is turned to another programme, the display will show the following: **Turn the programme selector to the last selected position.**

For each programme, the compatible options and other parameters are defined.



#### 3.3.2 Programme configuration

The table below lists the parameters that can be used to define the washing programmes.

<b>Types of fabric</b>	Cotton/linen, Synthetic fabrics, Delicates, Wool, Hand-wash, Shoes, Jeans, Duvet, Silk.
<b>Special programmes</b>	Soak, Miniprogramme, Easy-Iron, Conditioner, Rinses, Delicate rinses, Drain, Delicate spin, Spin.
<b>Temperature</b>	Normal, Maximum: the initial temperature is the maximum that can be selected for a specific washing programme.
<b>Spin</b>	Normal, Minimum, Maximum.
<b>Options (Normal / Possible)</b>	Pre-wash, Stains, Bleach, Extra rinse, Sensitive, Child lock, Memories, Setting, Short, Very short.
<b>Programme phases</b>	Pre-wash, Wash, Rinses, Spin, Delayed start.





#### First switching on

At first switching on of the appliance (turning the programme selector knob both clockwise and anti-clockwise) the LCD displays a short introduction to help the user programming the appliance.



Firstly, it is necessary to choose the language with which the messages will be displayed from now on.



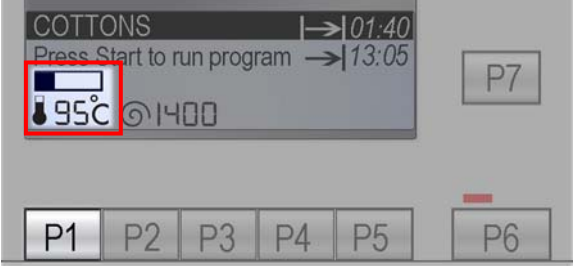
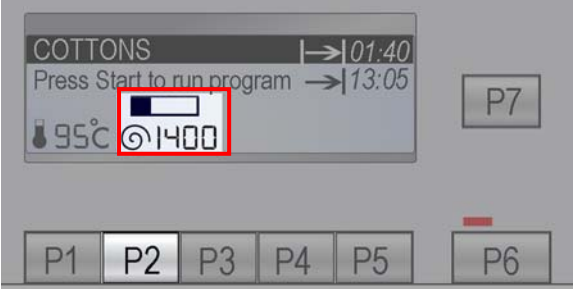

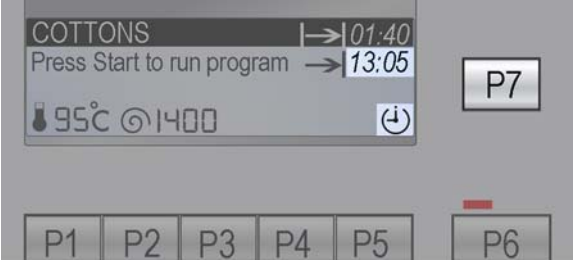
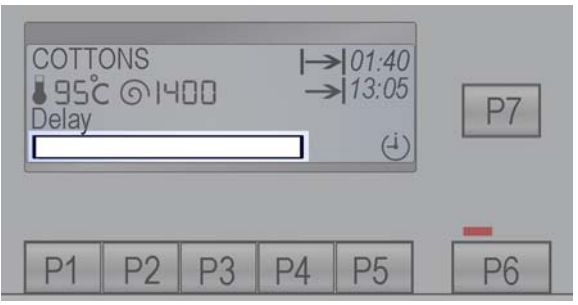

After selecting the language, it is necessary to set the clock. (Always maintain the clock time, because the end-of-cycle time depends on it). Pushing the **OPTIONS** button shortly, the variation is by minutes, while if the button press is prolonged, the variation is by ten minutes.

### 3.3.3 LCD and buttons

<ul style="list-style-type: none"> <li>◆ After turning the programme knob, the higher part of the display (black background and white characters) shows: On the left, the programme name, on the right its duration and below the end-of-cycle time. The duration of the programme is calculated automatically on the basis of the max load for each type of fabric and the time is updated every minute.</li> <li>◆ On the left, bottom of the display, you can find: -the temperature degrees of the programme; -the spin speed of the programme.</li> </ul>	
<ul style="list-style-type: none"> <li>◆ After some seconds the display shows: «Press Start to run program» (P6).</li> </ul>	
<ul style="list-style-type: none"> <li>◆ <b>LED off</b> : appliance off or the washing programme has finished.</li> </ul>	
<ul style="list-style-type: none"> <li>◆ <b>LED flashing</b>: the programme has been selected and it is possible to push the Start button to run the programme.</li> </ul>	
<ul style="list-style-type: none"> <li>◆ <b>LED fixed</b>: the appliance is performing a washing cycle.</li> </ul>	
<ul style="list-style-type: none"> <li>◆ <b>TEMPERATURE (P1)</b> If the temperature set by the programme it is not ok, modify it pushing button P1. The variation is indicated with some levels 95°,60°,50°,40°,30° and cold cycle. Above, the variation is shown by means of a scale. The selection of the cold cycle is represented by the symbol. ✱</li> </ul>	
<ul style="list-style-type: none"> <li>◆ <b>SPIN (P2)</b> If the spin set by the programme it is not ok, it is possible to modify it pushing button P2. The variation is indicated through some levels 1800, 1600, 1400, 1200, 1000, 800, 600, 400, Night cycle and Rinse hold. Above, the variation is shown by means of a scale. The selection of a Night cycle is represented by the symbol. ☾ --- The selection of Rinse hold is represented by symbol. ☐ ---</li> </ul>	

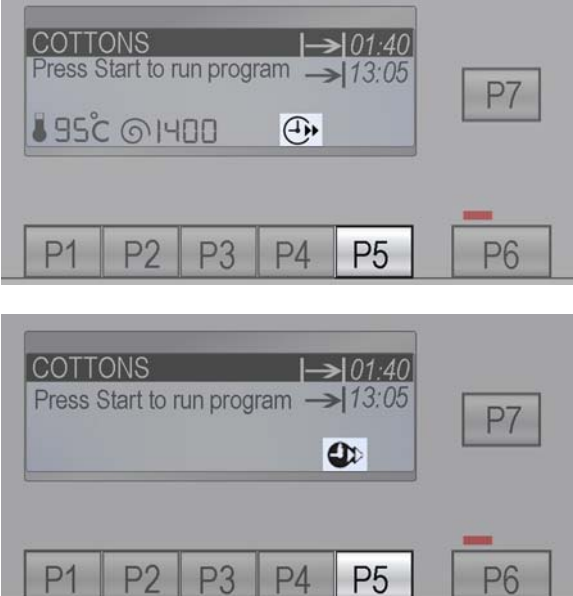

<ul style="list-style-type: none"> <li>◆ <b>OPTIONS (P3)</b> Pushing button P3 (under the chosen programme name) a list of possible options appears. Pushing the same button it is possible to scroll the list and the active option is highlighted by a black border around the option name.</li> </ul>	
<ul style="list-style-type: none"> <li>◆ <b>OK (P4)</b> If the option remains active for some seconds, the name changes to «Press OK». This is to help the user to choose. To confirm/deactivate an option push button P4.</li> </ul>	
<ul style="list-style-type: none"> <li>◆ After confirming the option, the relative symbol appears. Selecting an incompatible option with the others, these are automatically deactivated. When the appliance, at the end of the washing cycle is switched off, all selected options are cancelled. Only the «EXTRA RINSE» option remains active also in the following washing cycles.</li> </ul>	
<ul style="list-style-type: none"> <li>◆ <b>DELAYED START (P7)</b> Pushing the button P7, you can modify the end-of-cycle time, at intervals of 30' till two hours and at intervals of one hour till the max delay time of 20 hours. After setting the delay time, the symbol appears in the lower right part of the display and in the second line, for some seconds, the time to end. The time to end diminishes minute by minute.</li> </ul>	
<ul style="list-style-type: none"> <li>◆ After selecting the delay time and the washing cycle has started, in the lower left part of the display there is a bar with an index that indicates that the time is decreasing. When the delay time reaches zero, the bar and the symbol of the delayed start disappear and the washing cycle starts.</li> <li>◆ The cycle of the delayed start can be cancelled: Push the START/PAUSE button and push the DELAY START button till the delay time is cancelled.</li> </ul>	

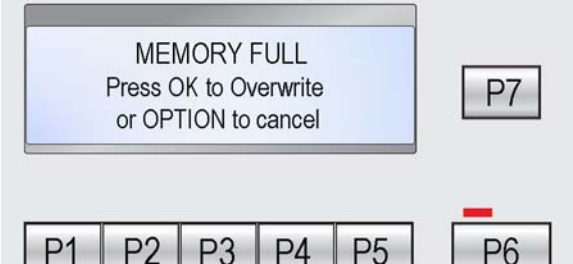
<ul style="list-style-type: none"> <li>◆ <b>TIME REDUCTION (P5)</b> When a washing cycle is selected, the one set is for a normally dirt clothes. The programme cycle can be modified pushing button P5.</li> <li>◆ This option can be selected only for programmes «Cottons», «Synthetics» and «Delicates»</li> <li>◆ Pushing once the button P5 the icon  lights up with a reduction of the washing time for daily clothes. Pushing twice the button P5 the icon  lights up with another washing time reduction for slightly dirty clothes.</li> </ul>	
<ul style="list-style-type: none"> <li>◆ <b>MEMORIZTION</b> Some positions of the programme selector are dedicated to the memorization of the washing cycles that the user can personalize, so as to avoid repetitive modifications to a programme, for ex the temperature, the spin speed and modify the options. When the appliance is new, all memories are empty. The user has to define them. Select a programme and do any possible modifications.</li> </ul>	
<p>Push button P3 and select the option "Program Memory". Push button P4.</p>	
<p>Pushing button P3 select in which memory you want the chosen programme. Push P4 to confirm.</p>	
<p>The display shows "SAVED".</p>	
<p>If in the chosen memory there is already a programme, the display shows "MEMORY FULL Press OK to Overwrite or OPTION to cancel".</p> <p>The content of the memories cannot be cancelled but only overwritten.</p>	

<p><b>“CHILD LOCK”</b></p> <p>This function is inserted inside the option menu. When it is activated, this function locks all controls and the door opening, after starting the programme, so as the children cannot change or cancel the programme.</p>	
<p>To activate this function, select pushing the option button (P3) the line with “CHILD LOCK”. To confirm the choice, push button (P4) and simultaneously the padlock symbol appears.</p>	
<p>The option remains active till it is not deactivated, pushing the OPTION (P3) and OK (P4) buttons simultaneously, the padlock symbol disappears.</p>	

<p><b>“SETTINGS”</b></p> <p>Inside this menu it is possible to regulate the “BUZZER”, the “LANGUAGE”, the ‘CLOCK”, the “BRIGHTNESS” and the CONTRAST. Please find below as example one regulation only, for the others the procedure is the same.</p>	
<p>Selecting “SETTINGS” with button (P3) and confirm the choice with button (P4) a menu composed by five lines appears.</p> <p>Select the brightness with button (P3).</p>	
<p>Confirming the selection with button (P4), it is possible to regulate the display luminosity. During the regulation phase a scale with a bar appears and under it a number (0÷9) that indicates the brightness level. The scale border in this phase flashes.</p>	
<p>With button (P3) it is possible to vary this level and to confirm the regulation push button (P4). Now the scale border scale border does not flash anymore.</p> <p>What it has been explained for the brightness, it is valid also for the contrast.</p>	
<ul style="list-style-type: none"> <li>◆ Language – possibility of choice between twenty-five; the language set by the factory is the one silk-screened on the control panel.</li> <li>◆ Clock – it can be selected only in the setting phase, not after the cycle start, so as to avoid a wrong time of the end of cycle.</li> <li>◆ Brightness and Contrast – from 0 = Min. to 9 = Max. level</li> <li>◆ Buzzer – two regulation levels (ON/OFF). It can be activated/deactivated at any time. When it is activated, it sounds at the end of the cycle and if an alarm occurs. When it is deactivated, it sounds only if an alarm occurs. The setting of the factory is Buzzer OFF; in some cases it can be Buzzer ON.</li> </ul>	

### EXECUTION OF WASHING PROGRAMME

During the washing cycle, the display shows: the name of the selected programme, the temperature and the spin speed of the cycle, the cycle phase and under an animated bar that indicates the washing cycle carried out (dark part of the bar) and the part of the programme to be executed (light part). In the top right corner, the remaining time of the cycle appears, under it the time at which the washing cycle ends (both the duration time and the end-of-cycle time can be influenced by: dirty filter, etc. and this includes the changing of the end-of-cycle time proposed at the start of the programme) and the options if they have been selected.

The main phases of washing programme are seven: Water fill, Heating, Washing, Rinses, Drain, Spin and End.



### PAUSE

A washing programme can be blocked momentarily during its execution pushing button P6: the LED starts flashing; the animated bar stops and it appears above "PAUSE".

During this time, it is possible to change the options and open the door if the temperature and the water level are low.



### END OF CYCLE

At the end of the washing cycle the name of the phase changes to "CYCLE FINISHED". If the door is locked alternatively to "CYCLE FINISHED" also "DOOR CLOSED" appears.

The duration time of the cycle (represented at the top left of the display) is displayed by "zeros" to indicate that the cycle has finished: **00:00**.

The LED above button P6 switches off.

If the washing cycle has finished with **water in tub**, alternatively to "DOOR CLOSED" the message that reminds to set the drain cycle appears.

If too much detergent has been used at the end of the cycle alternatively to "CYCLE FINISHED" also "DETERGENT OVERDOSING" appears.

At the end of the cycle an acoustic signal formed by three short beeps every 20" for the duration of 2'. This signal can be interrupted opening the door, turning the selector or pushing any button.

About 10' after the end of the cycle, if the appliance remains on, the backlighting shuts off and the LED starts flashing at a low frequency (a flash every 5" seconds).

To activate the backlighting just open the door or push any button.

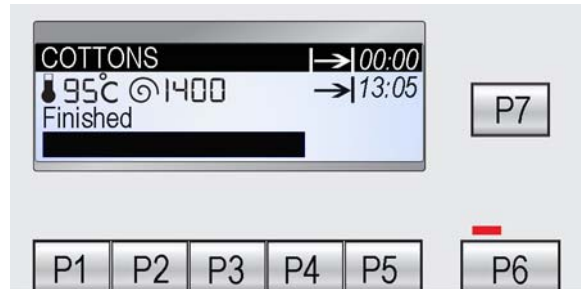

#### BLOCK/ CANCELLATION OF THE CYCLE

When a cycle is executing, it can be stopped or cancelled by turning the programme selector to OFF. When the appliance is switched on again, the display shows: "Press Start to resume program or press OK to cancel".

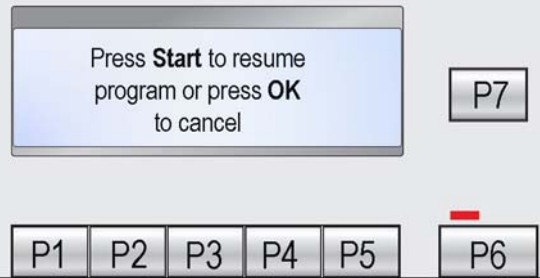

#### WARNINGS / ALARMS

During the washing cycle, the display can show some alarms or warnings that indicate the malfunctioning of the appliance, while the LED flashes and the Buzzer sounds.

During the displaying of an alarm, the display remains always on (not in stand-by) till the appliance is switched off.

Some problems are displayed and can be solved by the user.



## 4 DEMO

A special programme allows the demonstration of the operation of these appliances in shops, without the connection to the water system, in an interactive way with the user:

- ◆ The interactive way consists in selecting any programme, introducing some options and, after pushing the start button, the appliance will execute only some phases of the programme, skipping those that cannot be performed (water fill, drain, heating).

The cycle is performed as follows:

- ↺ The door lock device is activated normally (door locked during the operation, possibility to open it at the end of the cycle or in pause).
- ↺ Motor: all movements at low speed are activated; the pulses and the spin are deactivated.
- ↺ The water fill solenoids and the drain pump are deactivated.
- ↺ LCD: it displays all the programme phases very quickly.
- ↺ Alarms: for safety reasons the alarm families E40 (door closing), E50 (motor) and E90 (communication between board/configuration) are enabled.

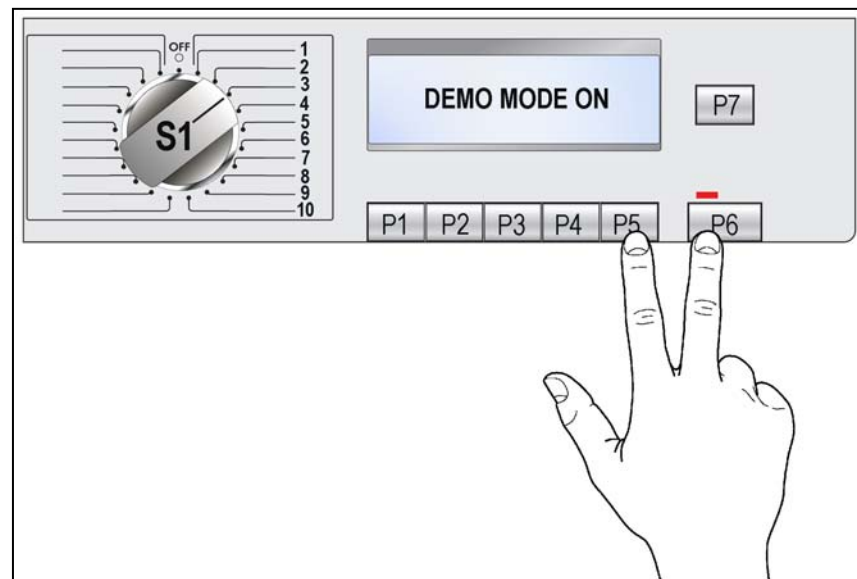

If after the setting of the Demo, the options and the programme are not modified, after three minutes a continuous cycle starts with the displaying of the various programme phases represented by the DISPLAY without powering the functional parts of the appliance.

To exit DEMO function, switch the appliance off.



## 5 DIAGNOSTIC SYSTEM

### 5.1 Access to diagnostics mode

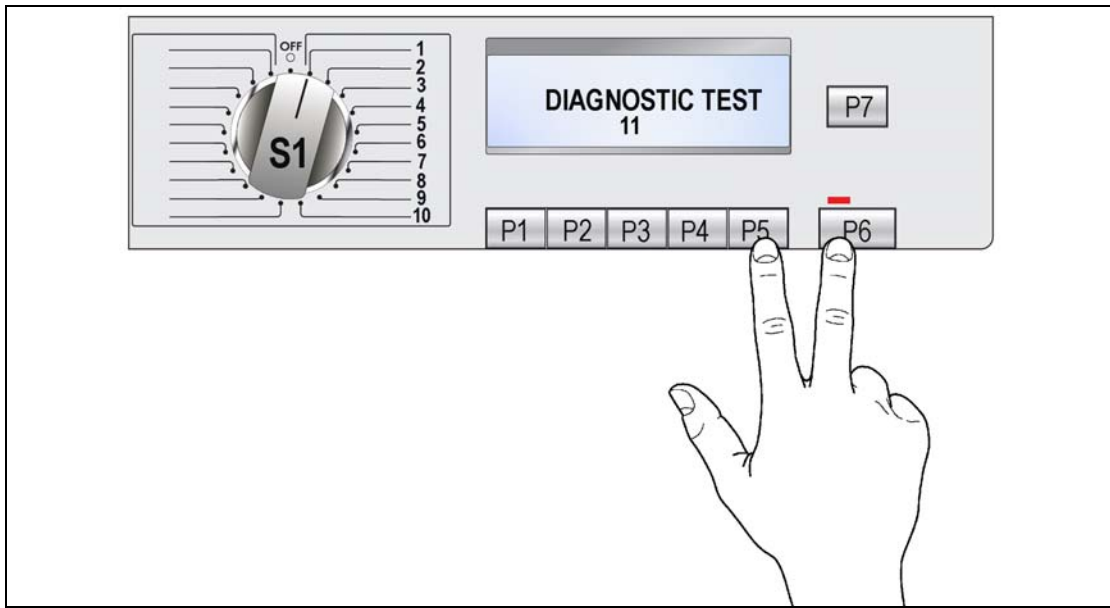

The diagram illustrates the control panel for entering diagnostic mode. On the left is a rotary selector knob labeled 'S1' with positions 1 through 10 and an 'OFF' position. To its right is a digital display showing 'DIAGNOSTIC TEST' and the number '11'. Further right is a button labeled 'P7'. Below the display is a row of seven buttons labeled 'P1' through 'P7'. A hand is shown pressing the 'P5' and 'P6' buttons simultaneously. The 'P6' button has a small red indicator light above it.

1. Switch off the appliance.
2. Press and hold down **START/PAUSE** button and the **P5** button (as represented in figure).
3. Holding down both buttons, switch the appliance on by turning the programme selector by **one position clockwise**.
1. Continue to hold down the buttons till the display lights up and the "DIAGNOSTIC TEST" appears.

In the first position, the operation of the buttons, the relative LEDs and the LCD display are checked; turning the selector knob **clockwise** the diagnostics cycle for the operation of the various components and the alarm reading is activated.







### 5.2 Exiting diagnostics mode

→ To exit the diagnostics cycle, switch the appliance off, then on, and then off again.

When the appliance is switched on again, it is necessary to set the time and language.

### 5.3 Diagnostics phases

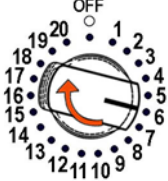
Irrespective of the type of PCB and the configuration of the programme selector it is possible, after entering diagnostics mode, to perform diagnostics on the operation of the various components and to read the alarms by turning the programme selector **clockwise**. All the alarms are enabled during the diagnostics cycle.

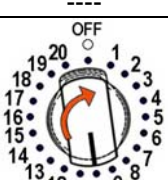
Selector position	Components actioned	Operating conditions	Function checked	LCD
1 	- All the LEDs and symbols light in sequence. - When a button is pressed, the corresponding LED or symbol light.	Always activated	Operation of the user interface	
2 	- Door interlock - Wash solenoid	Door locked Water level below anti-flooding level Maximum time 5 minutes	Water ducted through washing compartment	Displays the water level in tub
3 	- Door interlock - Pre-wash solenoid	Door locked Water level below anti-flooding level Maximum time 5 minutes	Water ducted through pre-wash compartment (bleach)	Displays the water level in tub
4 	- Door interlock - Pre-wash and wash solenoids	Door locked Water level below anti-flooding level Maximum time 5 minutes	Water ducted through conditioner compartment	Displays the water level in tub
5 	- Door interlock - Bleach/stains solenoids	Door locked Water level below anti-flooding level Maximum time 5 minutes	Water ducted through conditioner/stains compartments	Displays the water level in tub
6 	- Door interlock - Wash solenoid if the level of water in the tub does not cover the heater - Heating element - Recirculation pump	Door locked Water level above the heater Maximum time 10 minutes or up to 90°C (*)	Heating Recirculation	Wash water temperature
7 	- Door interlock - Wash solenoid if the level of water in the tub does not cover the heater - Motor (55 rpm clockwise, 55 rpm counter-clockwise, 250 rpm impulse)	Door locked Water level above the heater	Check for leaks from the tub	Displays the drum speed (the real value divided by ten)
8 	- Door interlock - Drain pump - Motor up to 650 rpm then at maximum spin speed	Door locked Water level lower than anti-boiling level for spinning	Drain and spin; control of congruence in closure of level pressure switches	Displays the drum speed (the real value divided by ten)
9 ----	----	----	----	
10 	- Reading/Cancellation of the last alarm	----	----	

(\*) In most cases, this time is sufficient to check the heating. However, the time can be increased by repeating the phase without draining the water: pass for a moment to a different phase of the diagnostics cycle and then back to the heating control phase (if the temperature is higher than 80°C, heating does not take place).

(\*\*) The check at the maximum speed occurs without control of the FUCS and no clothes have to be inserted inside the appliance.



### 5.3.1 Analysis of the LCD display during the diagnostic cycle

In position 1 the LCD display is displayed through the chessboard lighting (with different dimensions) of all the display points. Every time that during this test a button is pushed the test is interrupted and in the bottom centre the button codification in shown.

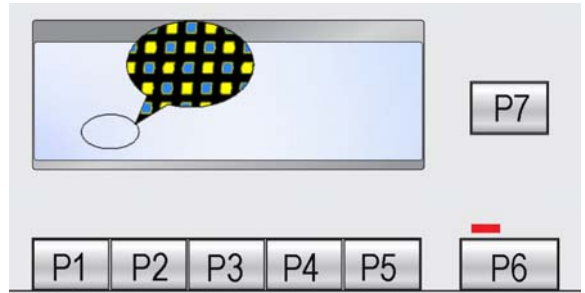

From position 2 to position 9 the display represents:

- The description of the phase being executed.
- The temperature on the left bottom side.
- The drum speed in the centre.
- The water level on the right.



In position 10 the reading alarm is shown.



## 6 ALARMS

### 6.1 Displaying the alarms to the user

The alarms are displayed by the flashing of the yellow LED placed above the START/PAUSE button and simultaneously through the LCD.



**The alarms displayed to the user are listed below:**

↪ E10 - Water fill difficulty (closed tap)

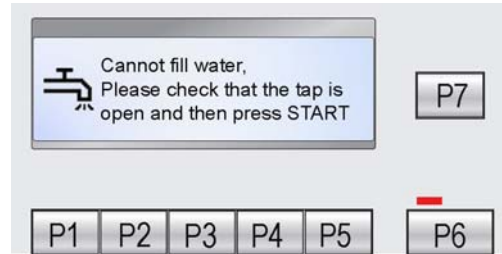

↪ E20 - Drain difficulty (dirty filter)

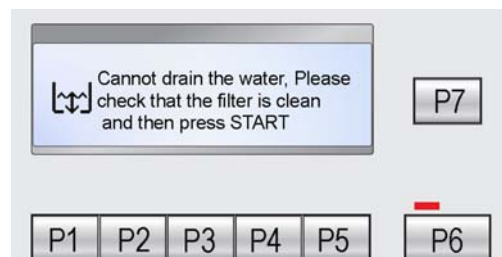

↪ E40 - Door open

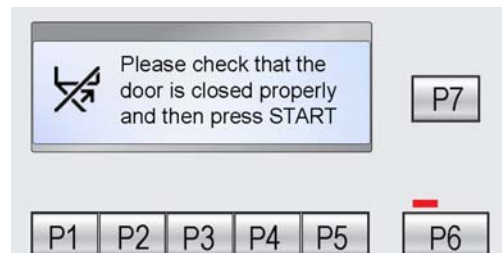

**They can be solved directly by the end user;**

**While the alarms listed below:**

↪ EF0 - Water leakage (Aqua Control System)

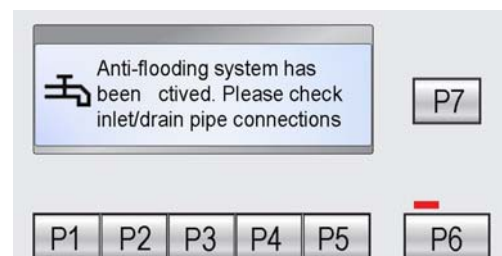

↪ EH0 - Voltage or frequency out of the normal values

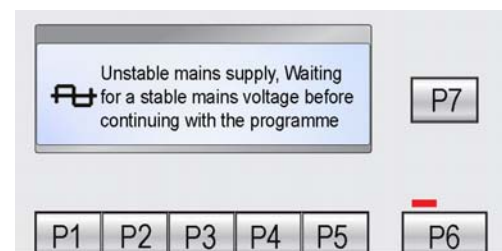

**They are displayed to the user, but for their solution it is necessary the intervention of the Service.**

The alarms are enabled during the execution of the washing programme, with the exception of alarms associated with configuration and the power supply (voltage/frequency), which are also displayed during the programme selection phase.

The door can normally be opened (except where specified) when an alarm condition has occurred on condition that:

- The level of the water in the tub is below a certain level
- Water temperature lower than 55°C
- Motor stopped

Certain alarm conditions require that a drain phase be performed before the door can be opened for safety reasons:

- Cooling water fill if the temperature is higher than 65°C
- Drain until the analogue pressure switch is on empty, during a max. 3-minute time.

## 6.2 Reading the alarm codes

It is possible to display the last three memorised alarms in the FLASH memory of the electronic board:

- Enter diagnostics mode (par. 4.1).
- Irrespective of the type of PCB and configuration, turn the programme selector **clockwise** to the **tenth position**.

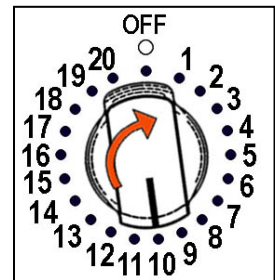

- The last alarm is displayed.



- To display the previous alarms, press button TEMPERATURE (1) or SPIN (2).



### 6.2.1 Displaying the alarm

The alarm is displayed by a repeated flashing sequence of the START / PAUSE button with yellow and red light (0,5 seconds on, 0,5 seconds off with a 2,5 second pause between the sequences).

- button indicator START / PAUSE with yellow light → indicates the first digit of the alarm code (family)
- button indicator START / PAUSE with red light → indicates the second digit of the alarm code (internal number of the family)

These two LEDs are featured in all models.

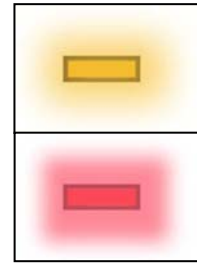

















#### Notes:

- The first letter of the alarm code "E" (Error) is not displayed, since this letter is common to all alarm codes.
- The alarm code "families" are shown in hexadecimal; in other words:
  - **A** is represented by **10** flashes
  - **B** is represented by **11** flashes
  - ...
  - **F** is represented by **15** flashes
- Configuration errors are shown by the flashing of all the LEDs (user interface not configured).

### 6.2.2 Examples of alarm display

Example: Alarm E43 (problems with the door interlock Triac) will display the following:

- the sequence of four flashes of the START / PAUSE button with yellow light, indicates the first number **E43**;
- the sequence of three flashes of the START / PAUSE button with red light, indicates the second number **E43**;

START / PAUSE button with yellow light			START / PAUSE button with red light		
ON / OFF	Time (Sec.)	Value	ON / OFF	Time (Sec.)	Value
	0.5	1		0.5	1
	0.5			0.5	
	0.5	2		0.5	2
	0.5			0.5	
	0.5	3		0.5	<b>3</b>
	0.5			0.5	
	0.5	<b>4</b>		2.5	Pause
	0.5				
	1.5	Pause			

### 6.2.3 Operation of alarms during diagnostics

All alarms are enabled during the components diagnostics phase.

### 6.3 Rapid reading of alarm codes

The last three alarm codes can be displayed even if the programme selector is not in the tenth position (diagnostics) or if the appliance is in normal operating mode (e.g. during the execution of the washing programme):

- Press and hold down **START/PAUSE** and the **P5** button (as to enter the DIAGNOSTICS), for at least two seconds: the display shows directly a screen with all the alarms.
- To return to the main screen press any button.
- The alarm reading system is as described in paragraph 5.2.
- While the alarms are displayed, the appliance continues to perform the cycle or, if in the programme selection phase, maintains the previously-selected options in memory.

### 6.4 Cancelling the last alarm

It is good practice to cancel the last alarm:

- after reading the alarm code, to check whether the alarm re-occurs during diagnostics;
- after repairing the appliance, to check whether it re-occurs during testing.

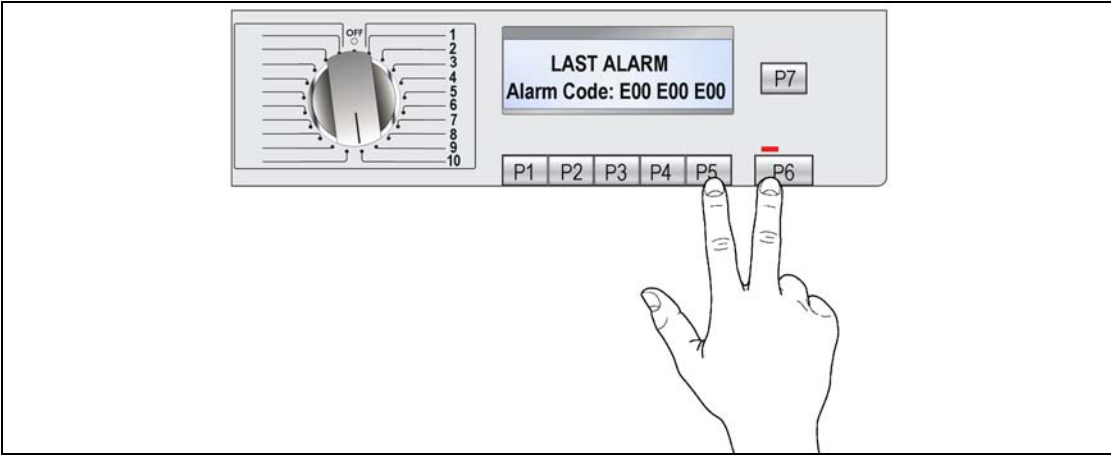

1. Select diagnostics mode and turn the programme selector to the **tenth** position (alarm reading,; the CD display shows only the last alarm while pushing the TEMPERATURE or SPIN button the history of the last three alarms is displayed).

2. Press the **START/PAUSE** and the **P5** button simultaneously (as represented in figure).

3. Hold down the buttons (at least 5 seconds) till the LCD display shows “E00” (for the first displaying) “E00 E00 E00” for the second option.

N.B. With this operation all the memorised alarms are deleted.

## 6.5 Cancelling the memories

To cancel the content of the memories, proceed as follows:

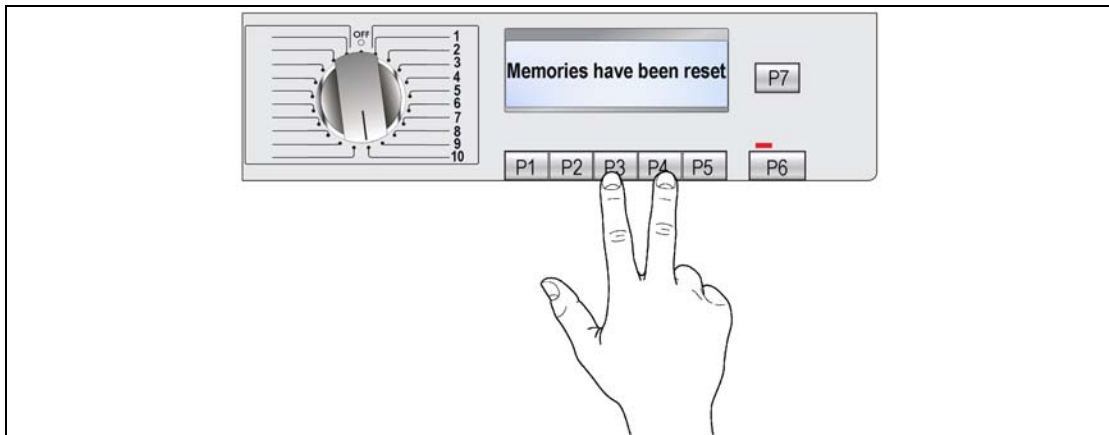

The diagram shows a control panel with a rotary programme selector on the left, numbered 1 to 10, with an 'OFF' position. To the right is an LCD display showing 'Memories have been reset' and a 'P7' button. Below the display are buttons labeled P1, P2, P3, P4, P5, and P6. A hand is shown pressing the P3 and P4 buttons simultaneously.

1. Select diagnostics mode and turn the programme selector to the **tenth** position.
2. Push the P 3 and 4 buttons simultaneously (as represented in figure).
3. Hold down the buttons till the LCD display shows "Memories have been reset" (at least 5 seconds).

## 7 OPERATING TIME COUNTER

Using a specific procedure, the operator can display the total operating time for the appliance, which is counted from the moment it is first switched on.

This option is available only on models equipped with a display. The unit can count up to a maximum of **6550** hours of operating time.

- Only the operating time of normal programmes (and not diagnostic programmes) is counted
- The actual operating time for the cycle is counted (which does not include pauses, delayed start time, time of a stop with water in the drum, and soaking phases)
- The precision of the counter is 30 seconds per programme
- Only whole hours of operation are counted (1 hr and 59 min = 1 hr)

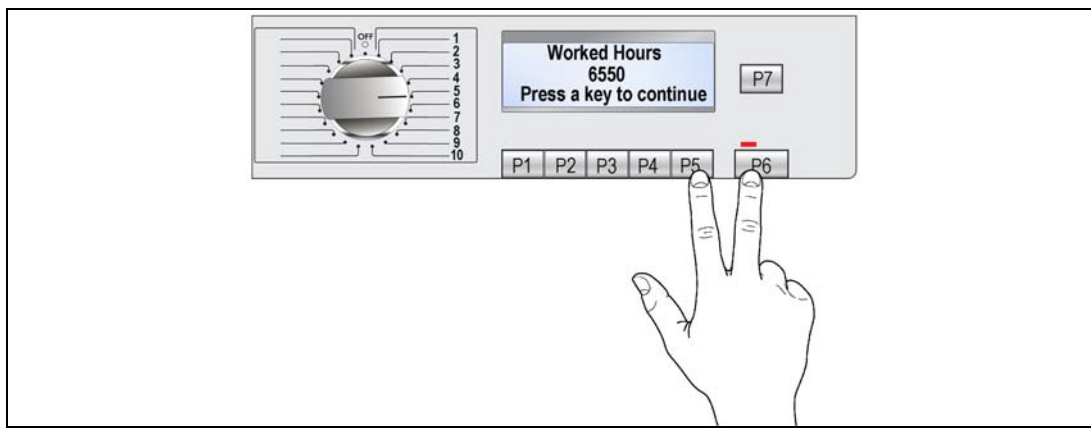

The diagram shows the same control panel as in the previous figure. The rotary programme selector is now turned to position 5. The LCD display shows 'Worked Hours 6550' and 'Press a key to continue'. A hand is shown pressing the P5 and P6 buttons simultaneously.

1. Switch off the appliance.
2. Press the **START/PAUSE** and the **P5** button simultaneously (as represented in figure).
3. Holding the buttons down, switch on the appliance turning the programme selector of **five positions clockwise**.
4. Hold the buttons down till the LCD shows "WORKED HOURS" (at least 5 seconds) and the display shows the number of the working hours of the appliance.

## 8 WASHING PROGRAMMES AND OPTIONS

### 8.1 Programmes

The washing programmes can be configured. The basic programmes are listed in the table below.

Programme		Temperature (°C)	Number of rinses	Final spin (rpm)
Cotton	90	82	3	Max. 1800
	90E	67(*)	(**)	
	60	60	3	
	60E	55 (*)	(**)	
	50	50	3	
	50/40E	44(*)	(**)	
	40	40	3	
	30	30		
	cold	20		
Synthetic fabrics	60	60	3	Max. 1200
	60/50E	42(*)	(**)	
	50	50	3	
	40	42		
	30	30		
	cold	20		
Mini Programme	30	30	3	Max. 900
	cold	20		
Delicates	40	40	3	Max. 1200
	30	30		
	cold	20		
Wool Hand-wash	40	38	3	Max. 1200
	30	33		
	cold	20		
Shoes	60	60	5	Max. 1200
	50	50		
	40	40		
	30	30		
	cold	20		
<b>Soak</b>		30/20	----	----
<b>Rinses</b>		----	3	Max. 1200
<b>Drain</b>		----	----	----
<b>Spin</b>		----	----	Max. 1800

The data are indicative.

(\*) "Energy label" programmes

(\*\*) In some countries the rinses are 3, in others 2

## 8.2 Options

The table below lists the possible options for the washing programmes, the compatibility of the various options and with the cycle, and when it is possible to select or modify the options.

The options can be selected in three ways:

- using the programme selector: in this case, the options are configured as special programmes;
- using the pushbuttons.

		OPTIONS															
		Rinse-hold	Night cycle	Pre-wash	Stains	Sensitive	Extra rinse	Easy-iron	Economy (*)	Intensive	Normal	Daily	Quick	Super Quick	Extra rinse	Easy-iron	
Compatibility with PROGRAMMES	Cotton	90°C	X	X	X	X	X	X	X	X	X	X	X	X	X	X	X
		60°C	X	X	X	X	X	X	X	X	X	X	X	X	X	X	X
		50°C	X	X	X	X	X	X	X	X	X	X	X	X	X	X	X
		40°C	X	X	X	X	X	X	X	X	X	X	X	X	X	X	X
		30°C	X	X	X		X	X	X		X	X	X		X	X	X
	cold	X	X	X		X	X	X		X	X	X		X	X	X	
	Cotton Economy	90°C	X	X	X	X	X	X	X	X						X	X
		60°C	X	X	X	X	X	X	X	X						X	X
		50°C	X	X	X	X	X	X	X	X						X	X
		40°C	X	X	X	X	X	X	X	X						X	X
	Synthetics	60°C	X	X	X	X	X	X	X	X		X	X		X	X	X
		50°C	X	X	X	X	X	X	X	X		X	X		X	X	X
		40°C	X	X	X	X	X	X	X	X	X	X	X		X	X	X
		30°C	X	X	X		X	X	X		X	X			X	X	X
	Delicates	cold	X	X	X		X	X	X		X	X			X	X	X
		40°C	X	X	X	X		X			X	X			X	X	X
		30°C	X	X	X			X			X	X			X	X	X
	Wool / Hand wash	cold	X	X							X	X			X	X	X
		30°C	X	X							X				X	X	X
		40°C	X	X							X				X	X	X
	Easy-iron	cold	X		X			X	X		X				X	X	X
		30°C	X		X			X	X		X				X	X	X
		40°C	X		X			X	X		X				X	X	X
		50°C	X		X			X	X		X				X	X	X
		60°C	X		X			X	X		X				X	X	X
	Duvet	cold	X		X			X	X		X				X	X	X
		30°C									X				X		
	Lingerie	40°C	X	X							X				X	X	X
		30°C	X	X							X				X	X	X
		cold	X	X							X				X	X	X
	Silk	30°C	X	X										X	X	X	X
		cold	X	X										X	X	X	X
	Jeans	60°C	X	X	X			X	X		X				X	X	X
		50°C	X	X	X			X	X		X				X	X	X
		40°C	X	X	X			X	X		X				X	X	X
		30°C	X	X	X			X	X		X				X	X	X
		cold	X	X	X			X	X		X				X	X	X
Short 20 min.	30°C												X	X	X		
MIX 40°-60°	40°C	X	X	X	X	X		X						X	X		
Hygienize	90°C	X	X		X		X	X		X				X	X	X	
	60°C	X	X		X		X	X		X				X	X	X	
	50°C	X	X		X		X	X		X				X	X	X	
	40°C	X	X		X		X	X		X				X	X	X	

(\*) Economy

Cotton: 90°C = Eco 67°C; 60°C = Energy Label; 50°-40°C = Eco 40° C AA

Synthetics: 60-60°C = Eco 40°C



X Option included in the programme and cannot be deleted

X Option included in the programme, can be activated/disabled through the option menu



			OPTIONS													
			Rinse-hold	Night cycle	Pre-wash	Stains	Sensitive	Extra rinse	Easy-iron	Economy (*)	Intensive	Normal	Daily	Quick	Super Quick	Reduced spin speed
Compatibility with PROGRAMMES	Curtains	40°C	X	X	X			X			X				X	X
		30°C	X	X	X			X			X				X	X
		cold	X	X	X			X			X				X	X
	Sanitise 60°	60°C	X		X	X		X	X		X				X	X
	Short Intensive for JET	60°C	X					X	X		X				X	X
		40°C	X					X	X		X				X	X
	Short Intensive for OKO COT + Quick	60°C	X					X	X				X		X	X
		40°C	X					X	X				X		X	X
	Sport	40°C	X					X	X		X				X	X
		30°C	X					X	X		X				X	X
		cold	X					X	X		X				X	X
	Rinses delicates		X	X				X							X	X
	Drain															
	Spin														X	

(\*) Economy

Cotton: 90°C = Eco 67°C; 60°C = Energy Label; 50°= Eco 48°C;40°C = Eco 44°C AA

Synthetics: 60-50°C = Eco 40°C

**X** Option included in the programme and cannot be deleted

**X** Only for JETSYSTEM+FLOWMETER

8.2.1 Compatibility between Options

		OPTIONS																
		Rinse-hold	Night cycle	Pre-wash	Stains	Bleach	Extra rinse	Easy-iron	Economy (*)	Intensive	Normal	Daily	Light	Quick	Super Quick	Reduced spin speed	No spin	Half-load
Compatibility with OPTIONS	Rinse-hold			X	X	X	X	X	X	X	X	X	X	X	X			X
	Night cycle			X	X	X	X		X	X	X	X	X	X	X			X
	Pre-wash	X	X		(*)	(*)	X	X	X	X	X	X	X	X	X	X	X	X
	Stains	X	X	(*)		(*)	X	X	X	X	X	X	X	X	X	X	X	X
	Bleach	X	X	(*)	(*)		X	X	X	X	X	X	X	X	X	X	X	
	Super rinse	X	X	X	X	X		X	X	X	X	X	X	X	X	X	X	X
	Easy-iron	X		X	X	X	X		X	X	X	X	X	X	X	X	X	X
	Economy	X	X	X	X	X	X	X									X	X
	Intensive	X	X	X	X	X	X	X									X	X
	Normal	X	X	X	X	X	X	X									X	X
	Daily	X	X	X	X	X	X	X									X	X
	Light	X	X	X	X	X	X	X									X	X
	Quick	X	X	X	X	X	X	X									X	X
	Super Quick	X	X	X	X	X	X	X									X	X
	Reduced spin speed			X	X	X	X	X	X	X	X	X	X	X	X	X		X
	No spin			X	X	X	X	X	X	X	X	X	X	X	X	X		X
Half-load	X	X	X	X		X	X	X	X	X	X					X	X	
Phases in which selection or modification are possible	Selection	X	X	X	X	X	X	X	X	X	X	X	X	X	X	X	X	
	Pre-wash	X	X		X	X	X	X								X	X	
	Wash	X	X		X	X	X									X	X	
	Rinses	X	X															
	Spin																	

(\*) Prewash, Stains and Bleach are compatible depending on which detergent drawer is used.

- The delayed start is compatible with all programmes, except for the drain; the max. time that can be selected is 20 hours.
- The spin selection is available for all programmes, except for the drain.

## 8.3 Descriptions of the options

- **Rinse-hold**

- Stops the appliance with water in the tub before the final spin cycle.
- To drain the water, reset the programme and then select a drain or spin cycle.

- **Night cycle**

- Eliminates all spin phases and adds **three** rinses in COTTON cycles and **two** rinses in SYNTHETICS cycles.
- Stops the appliance with water in the tub before the final rinse.
- Eliminates the buzzer (if configured)
- To drain the water, reset the programme and then select a drain or spin cycle.

- **Pre-wash**

- Adds a pre-wash phase at the start of the cycle with water heating to 30°C (or cold, if selected).
- In COTTON and SYNTHETICS cycles, performs a short spin before passing to the washing phase.
- This option cannot be selected for WOOL and HAND-WASH cycles.

- **Soak**

- Adds a pre-wash phase (with duration of 30' with wool cycle movement) at the start of the cycle with water heating to 30°C (or cold, if selected).
- In COTTON and SYNTHETICS cycles, performs a short spin before passing to the washing phase.
- Together with the delayed start option it is possible to select a soak time from 30min to 10 hours.
- This option cannot be selected for WOOL and HAND-WASH cycles.

- **Stains**

- Adds a 5-minute motor movement phase after heating to 40°C.
- Ducts water to the pre-wash/stains compartment in order to introduce the special stain-removal product.
- This option cannot be selected for DELICATES, WOOL and HAND-WASH cycles.

- **Bleach**

- Ducts water through the bleach compartment at the beginning of the first rinse in COTTON cycles.

- **Economy / Energy label**

- Modifies the structure of the COTTON 40-60 and SYNTHETICS 50/60 programmes in order to reduce energy consumption.
- Reduces the washing temperature.
- Increases the duration of the wash phase.

- **Super-rinse**

- Adds **two** rinses in the COTTON, SYNTHETICS and DELICATES cycles.
- Eliminates the intermediate spin cycles, with the exception of the final rinse, which is reduced to 450 rpm.

- **Half-load**

- Eliminates one rinse in COTTON programmes.

- **Easy-Iron**

- In COTTON programmes:
  - adds **three** rinse cycles
  - eliminates the intermediate spin cycles
  - performs an impulse spin phase
  - adds an "untangling" phase after the spin cycle
- In SYNTHETICS cycles:
  - reduces the heating temperature in 50/60° cycles to 40°C
  - increases the washing time
  - prolongs the cooling phase at the end of the washing phase
  - adds **one** rinse
  - adds an "untangling" phase after the impulse spin cycle

- **Reduced spin speed**

→ Reduces the speed of **all** spins as shown in the table.

<b>Maximum spin speed (rpm)</b>	600	700	800	900	1000	1100	1200	1300	1400	1550
<b>Reduction for COTTON (rpm)</b>	450	450	450	450	500	550	600	650	700	750
<b>Reduction for ALL OTHER CYCLES (rpm)</b>	450	450	450	450	450	450	450	450	450	450

- **No spin**

→ Eliminates **all** the spin phases.

→ If selected, three rinses are added in the COTTON cycle and one in the SYNTHETICS cycle.

- **Intensive**

→ Performs a specific intensive cycle.

- **Daily**

→ Modifies the structure of the COTTON - SYNTHETICS - DELICATES cycles to obtain a good washing performance with a short time.

- **Light**

→ Modifies the structure of the wash phase of the COTTON - SYNTHETICS - DELICATES cycles in a short time.

- **Short**

→ Modifies the structure of the COTTON - SYNTHETICS - DELICATES cycles to obtain very short washing times (optimized for reduced wash loads and very dirty).

→ Reduces the number of rinses (one rinse less).

→ Increases the water level of the other two rinses.

- **Very short**

→ Modifies the structure of the wash phase of the COTTON - SYNTHETICS - DELICATES cycles for half load

## 9 TECHNICAL CHARACTERISTICS

### 9.1 Control system memory



#### 9.1.1 General structure of the memory system

The system features an EEPROM memory module, fitted externally to the microprocessor, which serves to memorize the configuration data, the description of the cycle, the status of the appliance in the event of a power failure, and the alarms.

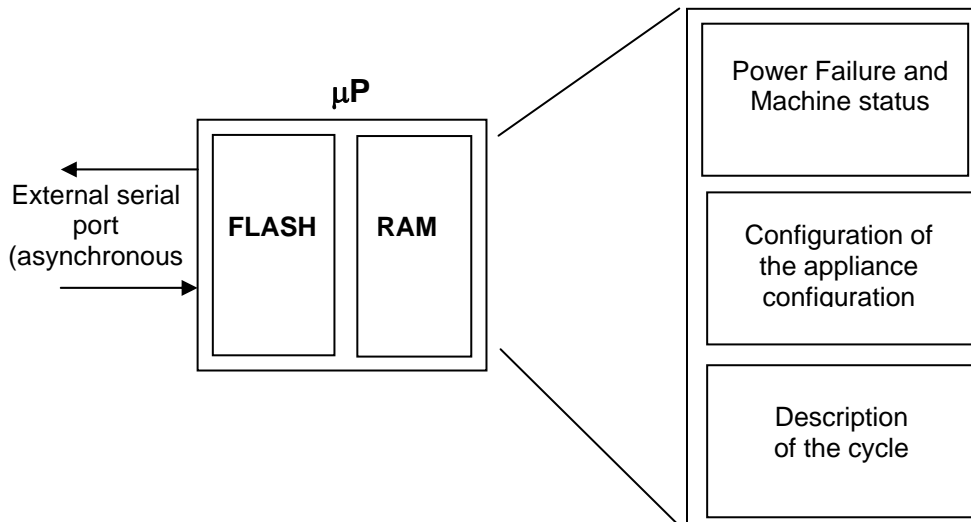

#### 9.1.2 FLASH

This area memory contains the firmware code relative to the functions of the appliance:

- ⇒ Control of electrical loads (motor, pump, solenoid valves etc.).
- ⇒ Control of the sensors (pressure switches, motor speed, door status etc.).
- ⇒ Control of the user interface
- ⇒ Control of the serial port
- ⇒ Control of power failure procedure and alarms
- ⇒ Execution of the washing programme
- ⇒ Power failure, i.e. the information necessary to restart the appliance in the event of a power failure:
  - Selected cycle and options
  - Current phase and sub-phase
- ⇒ Machine status, used to perform special cycles such as:
  - Electrical test (used in the assembly line)
  - Continuous cycles (used in the factory workshop)
- ⇒ Machine configuration: the data contained in the EEPROM define the characteristics of the model and are interpreted by the function software. The variables are as follows:
  - Type of appliance (front-loader, top-loader, compact)
  - Type of door interlock (PTC or instantaneous)
  - Anti-flooding safety device
  - Transmission ratio between drum pulley and motor pulley
  - Structure of the washing group
  - Power supply frequency (50/60 Hz)
  - Type of PCB (horizontal or vertical buttons)
  - Detergent drawer (3 or 4 compartments)
  - Final spin speed (600 – 1400 rpm)
- ⇒ Identification of the appliance:
  - Prod. N.
  - ELC
  - Serial number
- ⇒ Configuration of the user interface:
  - Programmes on main selector
  - Function of secondary selector (if featured)
  - Number and functions of buttons
  - Functions of the LEDs
  - Operation of the buzzer

- ⇒ Washing cycle tables: Each washing cycle consists of a series of phases (steps); the steps are the basic instructions which comprise the description of the cycle, which is common to all appliances having the same characteristics:
  - Water fill
  - Motor movement
  - Reset
  - Heating
  - Drain
  - Spin
  - "IF" conditions (options, temperatures etc.)
- ⇒ Configuration of the washing cycle: for each family of appliances, certain parameters associated with the washing programme are defined:
  - Operational limits (voltage/frequency)
  - Transmission ratios
  - Parameters for control of the signal from the tachometric generator
  - Parameters for half-range operation of the motor
  - Structure of the washing group
  - Control parameters for the FUCS anti-unbalancing system
  - Water fill control algorithm
  - Alarm control system
  - Sensor parameters (flowmeter etc...)

### 9.1.3 RAM

The RAM (Random-Access Memory) contains the variables, i.e. all the dynamic information used during execution of the programme:

- ⇒ Motor speed
- ⇒ Water temperature
- ⇒ Alarms
- ⇒ Cycle selected
- ⇒ Machine status

The RAM is cancelled when the power supply is disconnected (power failure or appliance switched off).

The contents of the RAM can be read using a computer connected via a DAAS interface.

The same system can be used to send commands to the electronic control unit such as:

- ⇒ Select remote control mode
- ⇒ Action the various loads in remote mode
- ⇒ Select diagnostics mode
- ⇒ Select a cycle and options, and start the cycle

## 9.2 Door interlock

There are two types of door interlock:

- voltmetric with PTC
- instantaneous

### 9.2.1 Voltmetric interlock with PTC

10 Suppressor  
19 Door interlock  
20 PCB

ON/OFF = Main switch (programme selector)

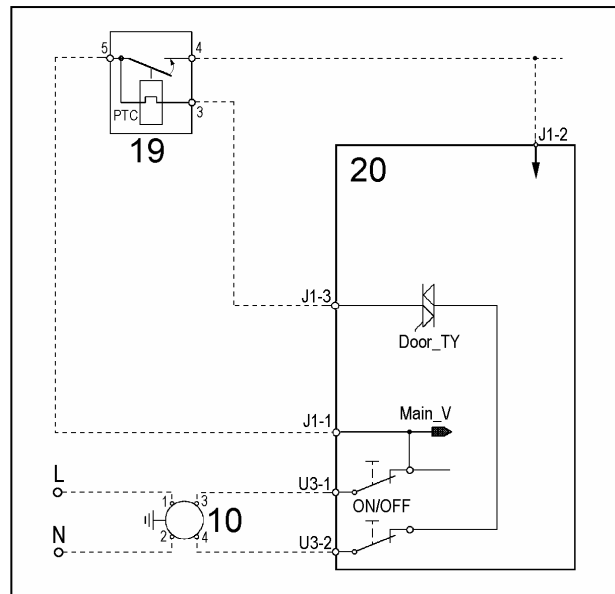

#### 9.2.1.1 Operating principle

- ↪ When the washing programme is started by pressing the START/PAUSE button, the bi-metal PTC (contacts 3-5) is powered by the triac on the PCB: after 2 – 4 seconds, this closes the switch (5-4) which powers the electrical components of the appliance (only if the door is closed).
- ↪ The door interlock prevents aperture of the door while the appliance is in operation.
- ↪ At the end of the washing programme, the PCB disconnects the interlock from the power supply, but the door remains locked for 1 to 3 minutes (PTC cooling time).

## 9.2.2 Instantaneous door interlock

- With this safety device it is possible to open the door immediately after the end of the cycle.

9 Door interlock  
 19 Suppressor  
 20 PCB

ON/OFF = Main switch (programme selector)

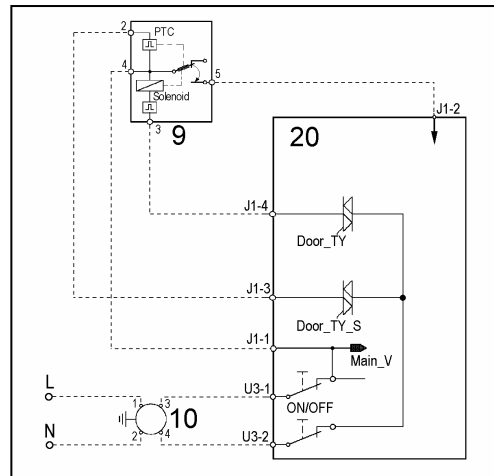

### 9.2.2.1 Operating principle

- ↪ When the ON/OFF switch closes and the appliance is switched on, power is applied to the bimetallic PTC switch (contact 4-2), but the door remains unlocked.
- ↪ When the programme starts (Start/Pause button), the main board sends a 20 msec pulse to contacts 4-3 on the solenoid (at least 6 seconds must have passed since the appliance was switched on). This locks the door and simultaneously closes the main switch (contacts 4-5), thus applying power to all components on the appliance.
- ↪ When the programme ends, the main board sends two additional 20 msec pulses (200 msec apart):
  - the first pulse does not unlock the door
  - the second pulse (which is sent only if the appliance is operating properly) unlocks the door lock device and simultaneously opens the contacts on the main switch.

### 9.2.2.2 Conditions required for opening the door

- ↪ Before pulses are sent to open the door, the main board checks for the following conditions:
  - The drum must not be moving (no signal from the tachometric generator).
  - The water level must not be higher than the bottom of the door.
  - The water temperature must not exceed 40° C.

### 9.2.2.3 Automatic unlock

If a power failure occurs, if the appliance is shut off, or if the solenoid malfunctions, the bimetallic PTC will cool down and the door will unlock in 1 - 4 minutes.



### 9.3 Water fill system

The electric valves are powered by the PCB by means of the triac and the control of the water level in the tub is carried out by the analogue pressure switch.

- 3 Analogue pressure switch
- 5 Prewash electric valve
- 6 Wash electric valve
- 7 Bleach electric valve
- 20 PCB

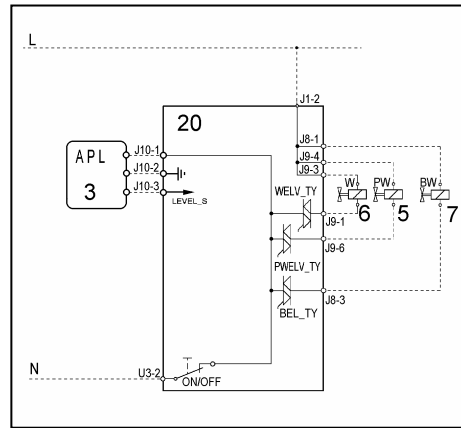

### 9.4 Analogue pressure switch of water level control in the tub

#### General features

The electronic pressure switch is an analogue device that controls the water level in the tub, used in the models with electronic control and it is directly connected to the main PCB.

ELECTRONIC PRESSURE SWITCH		
Electronic pressure switch	Electric symbol	

The pressure switch is connected by a hose to the pressure chamber.

When the tub is filled with water, the pressure created inside the hydraulic circuit expands the diaphragm. This in turn modifies the position of the core inside the coil, thus changing the inductance and the frequency of the oscillating circuit.

The electronic PCB, according to the frequency, recognizes the quantity of the water in the tub.

- 1 hose
- 3 coil
- 5 core

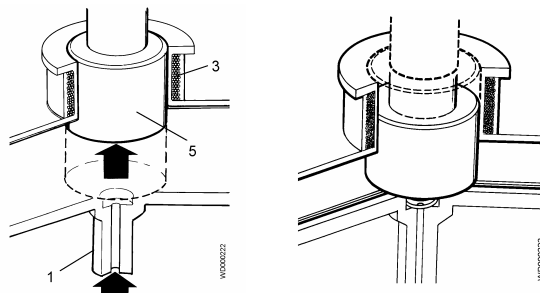

#### Frequency variation according to the water quantity in the tub

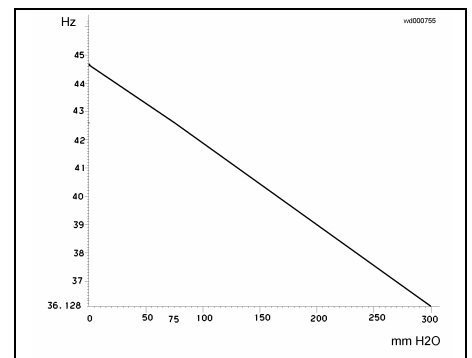

## 9.5 Drain pump

- 15 Drain pump
- 16 Thermal protector
- 20 PCB

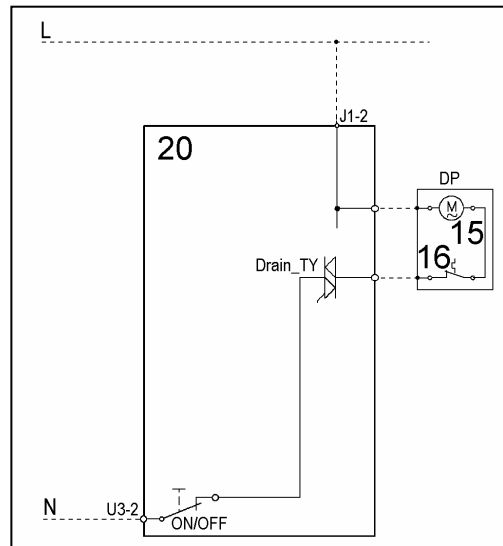

The PCB powers the drain pump via a triac as follows:

- until the electronic pressure switch closes on empty, after which the pump is actioned for a brief period or passes to the subsequent phase;
- for a pre-determined period (and eventually an alarm appears).

## 9.6 Recirculation pump (if featured)

On jetsystem models, the main board powers the recirculation pump through a triac.

- 17 Drain pump
- 18 Thermal protector
- 20 PCB

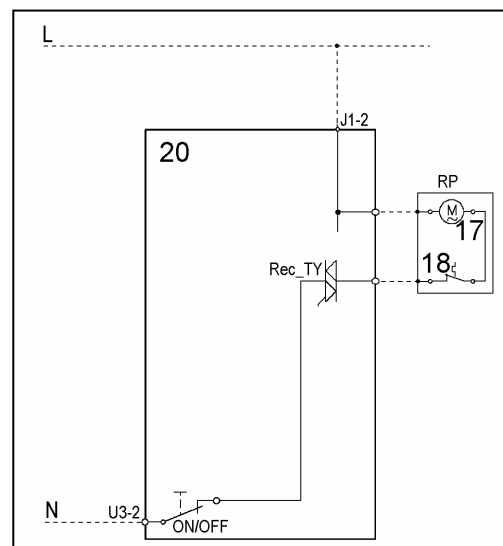

## 9.7 Heating



- 2 NTC temperature sensor
- 13 Heating element (with thermal fuses)
- 14 PCB
- K1 Relay

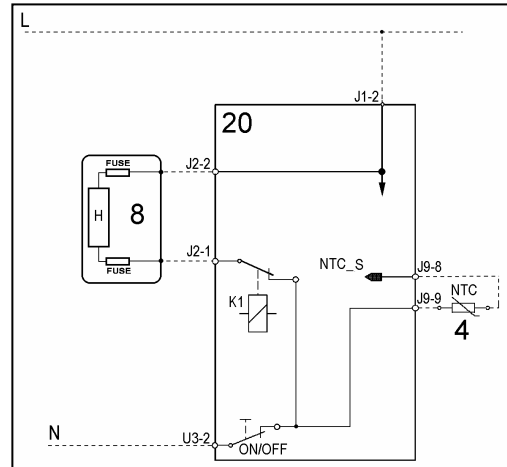

- 1. Tubular casing
- 2. Thermal fuses
- 3. NTC Sensor
- 4. Connectors

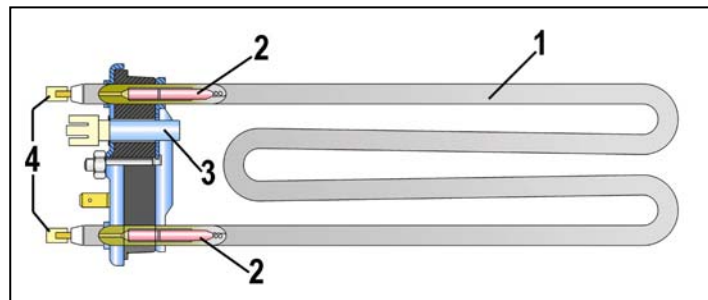

The heating element is powered by a relay (K1) of the electronic board and is provided with two thermal fuses, which interrupt if the temperature degree exceeds the values by which they are calibrated.

### WARNING



**In case of replacement of the heater, replace it with one with the same characteristics in order not to compromise the safety of the appliance.**

## 9.8 Temperature sensor

The temperature is controlled by the PCB by means of a NTC temperature sensor incorporated in the heating element.

- 1. NTC resistor
- 2. Metallic capsule
- 3. Terminals
- 4. Plastic casing

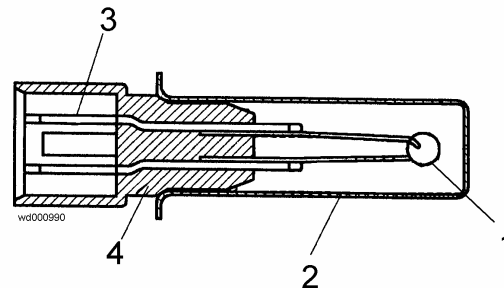

TEMPERATURE (°C)	RESISTANCE (Ω)		
	Nominal value	Maximum value	Minimum value
20	6050	6335	5765
60	1250	1278	1222
80	640	620	660

## 9.9 Three-phase asynchronous motor

- 11. Tachometric generator
- 20. PCB
- 23. Inverter
- 24. Motor

X-Y-X = Motor windings

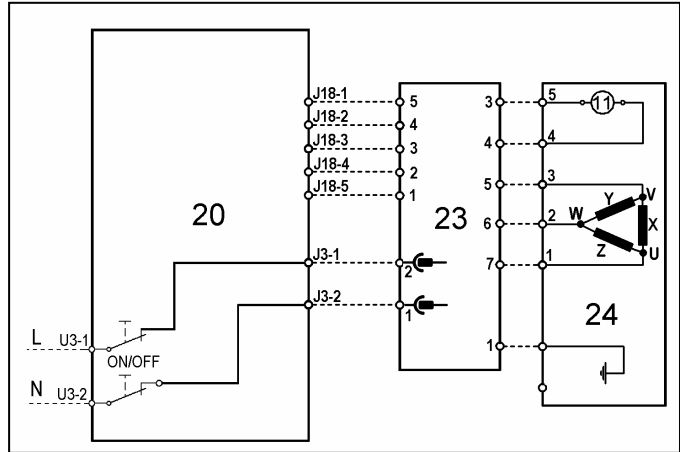

### 9.9.1 Power supply to motor

Three-phase power is fed by the inverter (4) which sends, through the connectors 5-6-7, the three phases to connectors 1-2-3 on the motor (nodes V-W-U), where the windings (Y-X-Z-) are connected. The phase shift between the phases is  $120^\circ$  and peak amplitude is 310V.

The condition of the motor can be determined by measuring the resistance of the windings:

- Winding y ohm 5,4  $\sim \pm 7\%$  (contacts 2-3)
- Winding x ohm 5,4  $\sim \pm 7\%$  (contacts 1-2)
- Winding z ohm 5,4  $\sim \pm 7\%$  (contacts 1-3)
- Winding T (tachometric) ohm 121  $\sim \pm 7\%$  (contacts 4-5)

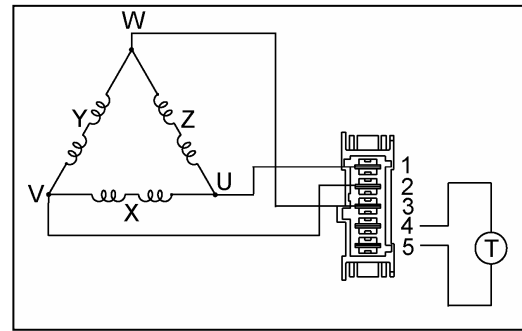

- The electrical components must be serviced by qualified personnel only.
- Unplug the appliance before accessing internal components.

## 9.10 Anti-foam control system

The anti-foam control procedure (if featured) is performed via the anti-boiling pressure switch.

### Spin phase without foam

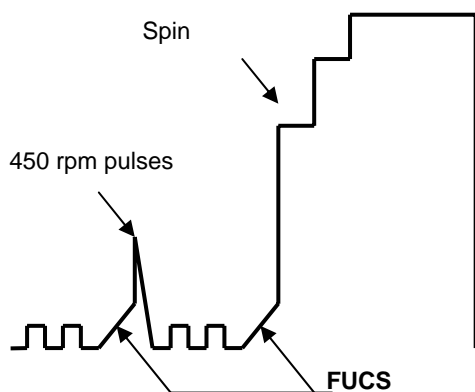

### Spin phase with little foam

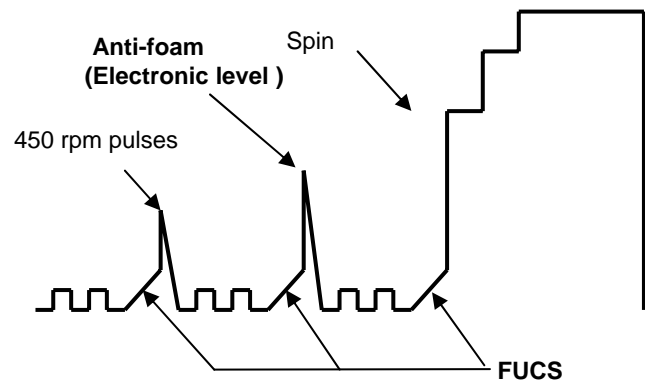

- **Spin with little foam:** if the contact of the electronic pressure switch closes on FULL, the spin phase is interrupted; the drain pump continues to operate and, when the contact returns to EMPTY, the spin phase is resumed.
- **Spin with excessive foam in the tub (critical situation):** The control system detects whether the electronic pressure switch commutates 5 times to FULL. In this case, the spin phase is skipped, and a one-minute drain cycle is performed with the motor switched off; in the case of a washing phase, a supplementary rinse is added.

## 9.11 FUCS (Fast Unbalance Control System)

The control procedure for unbalanced loads is performed dynamically, before each spin cycle, as follows:

- ↪ The phase begins at a speed of 55 RPM. The speed may not drop below this threshold; if it does, the check is repeated.
- ↪ At intervals of 300 ms, the balance is calculated and compared with established limits. If the value is lower than the limit, drum speed is increased by a certain amount that depends on the transmission ratio between the motor pulley and the drum. If unbalance is greater than the limit, the speed is decreased by the same amount, which enables the laundry to arrange itself correctly. The process continues until the load is completely balanced.
- ↪ Correct balancing of the load occurs at 115 RPM. After this speed is reached, the spin cycle begins.

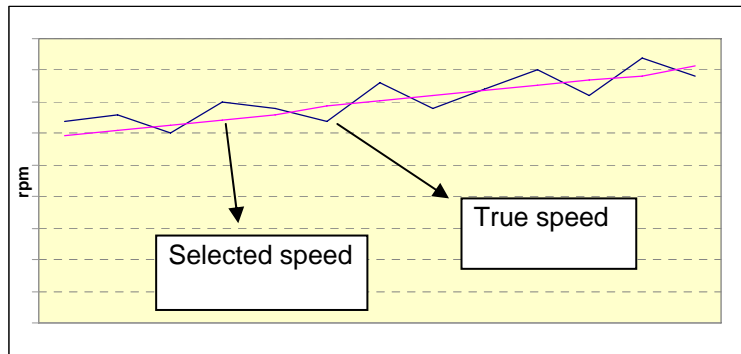

The unbalance control procedure may be performed in a number of phases. Each phase involves:

- ↪ an unbalancing rating (0-1-2-3)
- ↪ an unbalancing threshold (ex: 350, 650, 850, 1200g)
- ↪ a timeout

- **Conclusion of the FUCS procedure**

The FUCS procedure is considered to be concluded when:

- ↪ The speed of drum rotation is 115 RPM (or 85 RPM for certain unbalance ratings). At this point, the scheduled spin phase is carried out.
- ↪ In some cases, optimum balance is not reached and the spin is performed at a lower speed that depends on the level of unbalance.
- ↪ In the worst case scenario, a minimum level of balance is not achieved after all the FUCS phases have been performed and the spin phase is skipped.

- **Situation of ideal balancing**

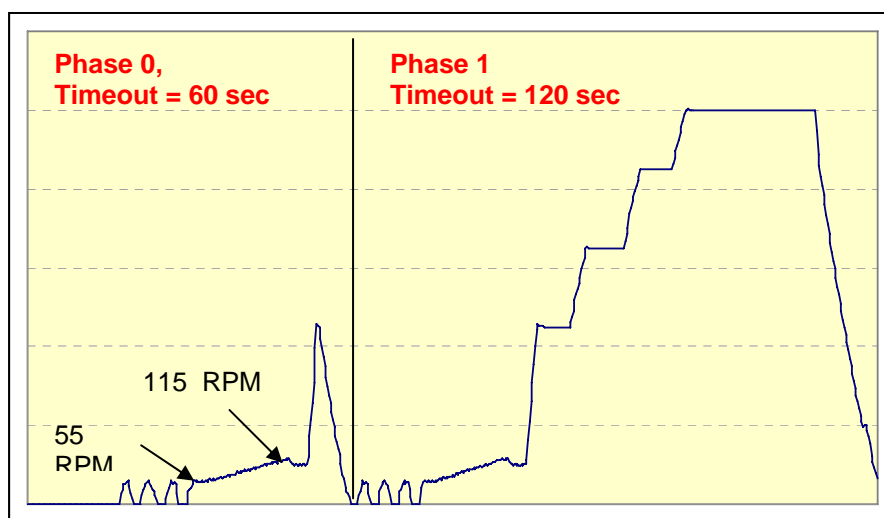

- An example of drum balancing in the longest interval of time available

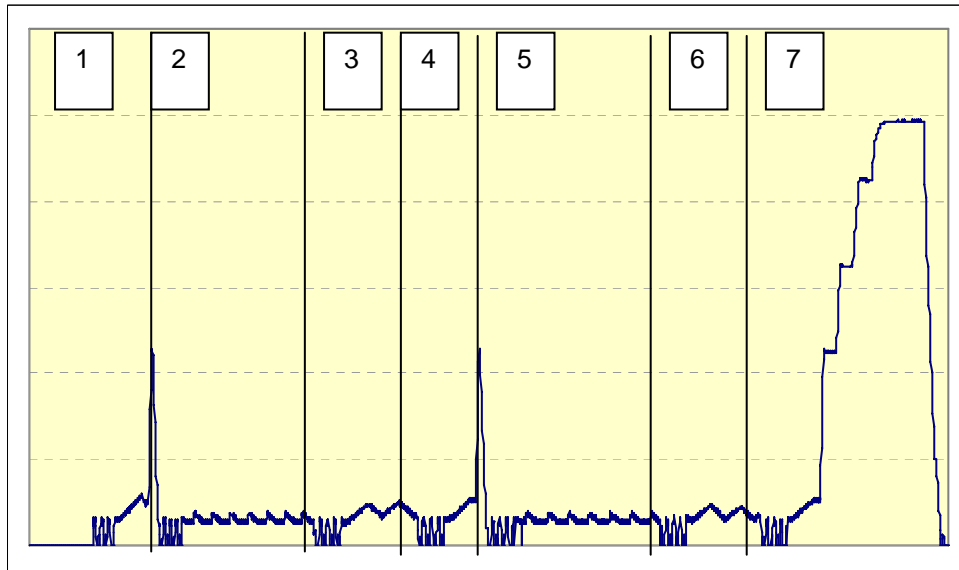

Phase	Unbalance rating	Time-out (sec)
1	0	60
2	1	120
3	2	60
4	3	90
5	1	120
6	2	60
7	3	90

- An example of unbalancing after all FUCS phases have been performed

In this case, the spin (or pulse operation) is skipped.

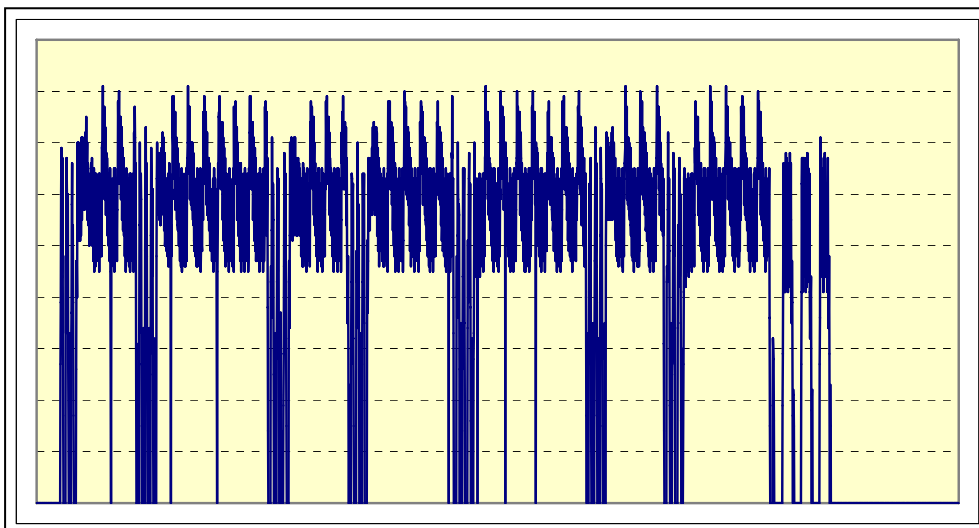

## 10 Table of alarm codes of the main PCB

Alarm	Possible fault	Action/machine status	Reset
E11	Tap closed or water pressure too low; Drain tube improperly positioned; Water fill solenoid valve is faulty; Leaks from water circuit on pressure switch; Pressure switch faulty; Wiring faulty; PCB faulty.	Cycle is paused with door locked.	START/RESET
E12	Tap closed or water pressure too low; Drain tube improperly positioned; Water fill solenoid valve is faulty; Leaks from water circuit on pressure switch; Pressure switch faulty; Wiring faulty; PCB faulty.	Cycle is paused with door locked.	START/RESET
E13	Drain tube improperly positioned; Water pressure too low; Water fill solenoid valve is faulty; Water circuit on pressure switch is leaking/clogged; Pressure switch faulty.	Cycle is paused with door locked.	START/RESET
E21	Drain tube kinked/clogged/improperly positioned; Drain filter clogged/dirty; Drain pump faulty; Pressure switch faulty; Wiring faulty; PCB faulty; Electrical current leak between heating element and ground.	Cycle is paused (after 2 attempts).	START/RESET
E22	Drain tube kinked/clogged/improperly positioned; Drain filter clogged/dirty; Drain pump faulty; Pressure switch faulty; Wiring faulty; PCB faulty; Electrical current leak between heating element and ground.	Cycle is paused	START/RESET
E23	Drain pump faulty; Wiring faulty; PCB faulty.	Safety drain cycle - Cycle stops with door unlocked.	RESET
E24	PCB faulty.	Safety drain cycle - Cycle stops with door unlocked.	RESET
E31	Pressure switch; Wiring; Main PCB.	Cycle stops with door locked.	RESET
E32	Drain tube kinked/clogged/improperly positioned; Drain filter clogged/dirty; Drain pump faulty; Water circuit on pressure switch; pressure switch; Wiring; main board.	Cycle is paused.	START/RESET
E35	Water fill solenoid valve is faulty; Leaks from water circuit on pressure switch; Pressure switch faulty; Wiring faulty; PCB faulty.	Cycle stops. Safety drain cycle. Drain pump continues to operate (5 min. on, then 5 min. off, etc.).	RESET
E38	Water circuit on pressure switches; Pressure switches; Motor belt broken.	Heating phase is skipped.	ON/OFF RESET
E3A	PCB faulty.	Cycle stops with door locked.	RESET
E41	Door lock unit faulty; Wiring faulty; PCB faulty.	Cycle is paused.	START/RESET



<b>Alarm</b>	<b>Possible fault</b>	<b>Action/machine status</b>	<b>Reset</b>
<b>E42</b>	Door lock unit faulty; Wiring faulty; PCB faulty.	Cycle is paused.	START/RESET
<b>E43</b>	Door lock unit faulty; Wiring faulty; PCB faulty.	(Safety drain cycle) Cycle stops.	ON/OFF RESET
<b>E44</b>	PCB faulty.	(Safety drain cycle) Cycle stops.	ON/OFF RESET
<b>E45</b>	PCB faulty.	(Safety drain cycle) Cycle stops.	ON/OFF RESET
<b>E51</b>	PCB faulty; current leakage from motor or from wiring.	Cycle blocked, door locked (after 5 attempts).	RESET
<b>E52</b>	Motor faulty; wiring faulty; PCB faulty.	Cycle blocked, door locked (after 5 attempts).	RESET
<b>E53</b>	PCB faulty.	Cycle blocked, door locked.	RESET
<b>E54</b>	PCB faulty; current leakage from motor or from wiring.	Cycle blocked, door locked (after 5 attempts).	RESET
<b>E57</b>	Wiring defective on inverter for motor, inverter board defective.	Cycle stops with door locked (after 5 attempts).	RESET
<b>E58</b>	Wiring defective on inverter for motor, inverter board defective, abnormal motor operation (motor overloaded); Motor defective.	Cycle stops with door locked (after 5 attempts).	RESET
<b>E59</b>	Motor defective; Wiring defective on inverter for motor; Inverter board defective.	Cycle stops with door locked (after 5 attempts).	RESET
<b>E5A</b>	Inverter board defective. NTC open (on the inverter board). Overheating caused by continuous operation or ambient conditions (let appliance cool down).	Cycle stops with door locked (after 5 attempts).	RESET
<b>E5H</b>	Wiring defective, Inverter board defective.	Cycle stops with door locked (after 5 attempts).	RESET
<b>E5C</b>	Inverter board defective, the masters voltage is too high (measure the masters voltage).	Cycle stops with door locked (after 5 attempts).	RESET
<b>E5d</b>	Line interference, Wiring defective, defective main board or inverter board.	Cycle stops with door locked (after 5 attempts).	RESET
<b>E5E</b>	Defective wiring between main board and inverter board, Defective inverter board, defective main board.	Cycle stops	ON/OFF
<b>E5F</b>	Defective inverter board, Defective wiring, defective main board.	Cycle stops with door locked (after 5 attempts).	RESET
<b>E61</b>	NTC sensor faulty; heating element faulty; wiring faulty; PCB faulty.	The heating phase is skipped.	START/RESET
<b>E62</b>	NTC sensor faulty; heating element faulty; wiring faulty; PCB faulty.	Safety drain cycle – Cycle stopped with door open.	RESET
<b>E66</b>	PCB faulty.	Safety drain cycle – Cycle stopped with door open.	RESET
<b>E68</b>	Earth-leakage between heater and earth.	Cycle blocked with door open.	RESET

<b>Alarm</b>	<b>Possible fault</b>	<b>Action/machine status</b>	<b>Reset</b>
<b>E69</b>	Washing heating element interrupted (thermofuse open)	-----	START/RESET
<b>E71</b>	Faulty NTC sensor; Wiring faulty; PCB faulty.	Heating is skipped.	START/RESET
<b>E72</b>	Wiring faulty; Drying NTC sensor (condenser) faulty; PCB faulty.	Drying heating is skipped	START/RESET
<b>E73</b>	Wiring faulty; Drying NTC sensor (duct) faulty; PCB faulty.	Drying heating is skipped	START/RESET
<b>E74</b>	NTC sensor improperly positioned; Faulty NTC sensor; Wiring faulty; PCB faulty.	Heating is skipped.	START/RESET
<b>E82</b>	PCB faulty (Wrong configuration data). Selector, wiring	-----	RESET
<b>E83</b>	PCB faulty (Wrong configuration data). Selector, wiring	Cycle cancelled.	START/RESET
<b>E91</b>	Wiring faulty; Faulty control/display board PCB faulty.	-----	RESET
<b>E92</b>	Wrong control/display board; Wrong PCB (do not correspond to the model).	Cycle interrupted.	OFF/ON START
<b>E93</b>	Incorrect configuration data; PCB faulty.	Cycle interrupted.	OFF/ON
<b>E94</b>	Incorrect configuration data; PCB faulty.	Cycle interrupted.	OFF/ON
<b>E95</b>	PCB faulty.	Cycle interrupted.	RESET
<b>E97</b>	Faulty PCB (Wrong configuration data).	Cycle interrupted.	RESET
<b>E98</b>	Incompatibility between main board and Inverter.	Cycle interrupted.	OFF/ON
<b>E9b / E9H</b>	Display board.	Cycle interrupted.	ON/OFF RESET
<b>E9C</b>	Display board.	Cycle interrupted.	ON/OFF RESET
<b>E9d</b>	Display board.	Cycle interrupted.	ON/OFF RESET
<b>E9F</b>	PCB.	Cycle interrupted.	OFF/ON
<b>EH1</b>	Power supply problems (incorrect / disturbance); PCB faulty.	Wait for frequency nominal conditions.	OFF/ON
<b>EH2</b>	Power supply problems (incorrect / disturbance); PCB faulty.	Wait for voltage nominal conditions.	OFF/ON
<b>EH3</b>	Power supply problems (incorrect / disturbance); PCB faulty.	Wait for voltage nominal conditions.	OFF/ON
<b>EHE</b>	Wiring faulty; PCB faulty.	Safety drain cycle – Cycle stopped with door open.	RESET
<b>EHF</b>	PCB faulty.	Safety drain cycle – Cycle stopped with door open.	RESET
<b>EC1</b>	Solenoid valve faulty/blocked; PCB faulty.	Cycle interrupted with door closed. Drain pump functions always (5 min., then it stops for 5 min. etc.)	RESET
<b>EC3</b>	Wiring faulty; Weight sensor faulty; PCB faulty.	-----	START/RESET
<b>Ed1</b>	Wiring faulty between PCB and WD board; WD board faulty; PCB faulty.	Cycle interrupted.	OFF/ON
<b>Ed2</b>	Wiring faulty between PCB and WD thermostats; WD board faulty; PCB faulty.	Cycle interrupted with door open.	RESET
<b>Ed3</b>	Wiring faulty between PCB and WD thermostats; WD board faulty; PCB faulty.	Cycle interrupted with door open.	RESET
<b>Ed4</b>	Wiring faulty; WD board faulty; PCB faulty.	Cycle interrupted with door open.	RESET

<b>Alarm</b>	<b>Possible fault</b>	<b>Action/machine status</b>	<b>Reset</b>
<b>EF1</b>	Drain tube blocked/kinked/too high; Drain filter dirty/blocked.	Warning displayed at the end of cycle (specific LED).	START/RESET
<b>EF2</b>	Excessive detergent dosing; drain tube kinked/blocked; Drain filter dirty/blocked.	Warning displayed after 5 attempts or by the specific LED.	RESET
<b>EF3</b>	Water leaks onto base frame; water control system defective.	Machine drains and cycle stops	ON/OFF RESET
<b>EF4</b>	Tap closed, water pressure too low.	-----	RESET
<b>EF5</b>	Final spin phases skipped.	-----	RESET
<b>E00</b>	-----	-----	-----

# 11 Diagram with THREE-PHASE ASYNCHRONOUS MOTOR

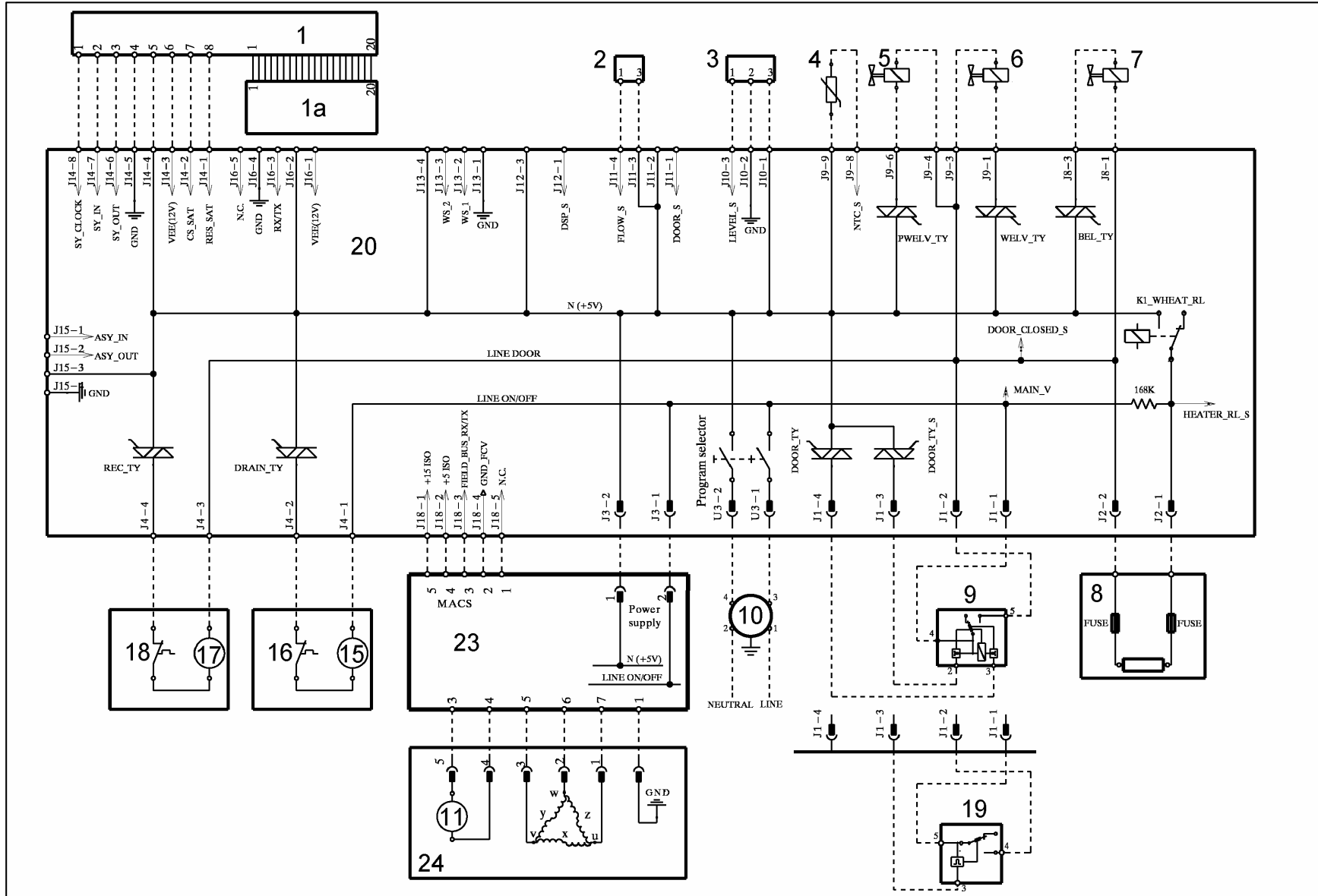

- Key to diagram with THREE-PHASE ASYNCHRNOUS MOTOR

Electrical components on appliance	Components on main board	
1. Display board 1a. LCD display 2. Flowmeter 3. Analogue pressure switch 4. NTC temperature sensor 5. Solenoid valve for prewash 6. Solenoid valve for wash 7. Solenoid valve for bleach 8. Heating element (with thermofuses) 9. Door interlock (instantaneous) 10. Suppressor 15. Drain pump 16. Thermal cut-out (drain pump) 17. Recirculation pump 18. Thermal cut-out (recirculation pump) 19. Door interlock (with PTC) 20. PCB 23. Inverter 24. Three-phase motor	DOOR_TY DRAIN_TY REC-TY K1 ON/OFF PWELV_TY WELV_TY BEL_TY	Door interlock Triac Drain pump Triac Recirculation pump Triac Heating element relay Main switch (programme selector) Pre-wash solenoid Triac Wash solenoid Triac Bleach solenoid Triac

## 12 ACCESSIBILITY TO THE ELECTRONIC CONTROL SYSTEM

### 12.1.1 Work top

- a. Remove the two rear screws, push the top panel towards the rear and release from the cabinet.

### 12.1.2 Control panel

- b. Extract the drawer.



- d. Remove the screw which secures the control panel to the dispenser.



- d. Release the clamp from the cross-member.
- e. Cut the clamp which secures the wiring to the board casing (while re-assembling, put a new clamp).

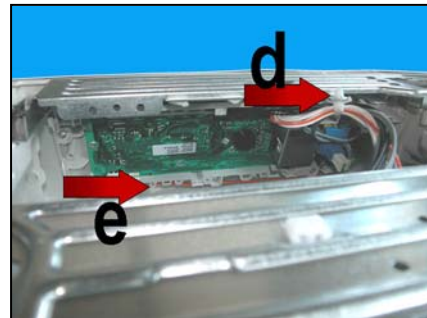

- f. Loosen the screws which secure the cross-member to the cabinet and that central to the conveyor.
- g. Release the hook of the dispenser to the cross-member.
- h. Loosen the screws and release the hook which secures the control panel to the cross-member.

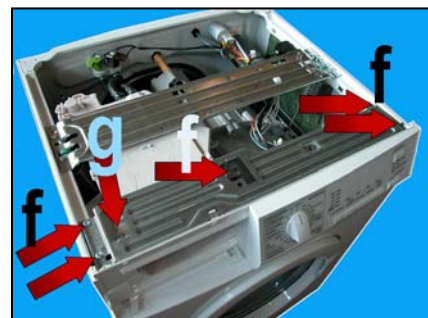

- a. Lift the control panel up and extract it.



- b. Rotate the control panel around itself.



- c. Place it as indicated in figure paying attention not to scrape it.



- e. Remove the screws and release the hooks which secure the board casing to the control panel.

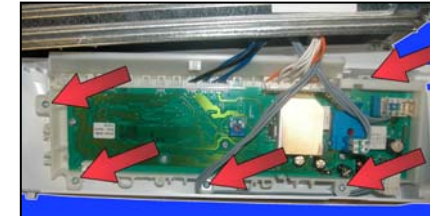

- f. Before mounting the new board extract the knob pressing the hooks indicated by the arrows as represented in figure.

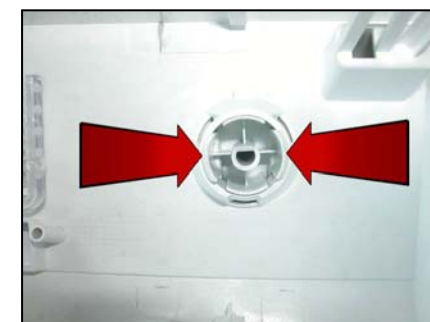

While re-assembling repeat the same operations in reverse order and pay attention to position correctly the knob.



While remounting the work top please pay attention not to position it as in fig. A but as in fig. B.

