

*DS Golf Car*

**Electric  
Vehicles**

# 2003 Owner's Manual



play to win



## NOTICE

---

The Club Car Limited Warranty for owners of individual golf cars appears on the pages following this notice, and the Limited Lifetime Fleet Warranty appears at the end of this manual, along with limited warranty information for 2003 T-105 6-Volt Batteries, 2003 PowerDrive 8-Volt Batteries, 2003 36-Volt Battery Chargers, 2003 PowerDrive Battery Chargers, and 2003 Onboard Computers and Solid State Speed Controllers. No other warranties, expressed or implied, are contained herein. Your authorized representative checked the vehicle before it was delivered to you and will provide you a copy of the completed vehicle warranty registration form.

Club Car is not liable for errors in this manual or for incidental or consequential damages that result from the use of the material in this manual.

This vehicle conforms to the current American National Standards Institute's Z130 Safety and Performance Requirements for Golf Cars. This standard, which promotes safety in the design, application, and operation of golf cars, defines a golf car as "a vehicle used to convey a person or persons and equipment to play the game of golf in an area designated as a golf course." Throughout this manual, the words "golf car" and "vehicle" are used interchangeably.

This manual contains proprietary information that is protected by copyright. All rights are reserved. No part of this manual may be photocopied, reproduced, or translated to another language without the written consent of Club Car, Inc.

The information contained in this document is subject to change without notice.

Club Car reserves the right to make design changes to vehicles without obligation to make these changes on units previously sold.

These vehicles do not conform to Federal Motor Vehicle Safety Standards for automobiles or to FMVSS 500 for low-speed vehicles, and are not equipped for operation on public streets, roads, or highways.



**P. O. Box 204658**  
**Augusta, Georgia 30917-4658 USA**  
**Telephone 706-863-3000**  
**Service Parts Fax 706-855-7413**  
**[www.clubcar.com](http://www.clubcar.com)**

Copyright © 2002 Club Car, Inc.  
*Club Car*, *ArmorFlex*, and *PowerDrive*  
are registered trademarks of Club Car, Inc.  
This manual effective July 22, 2002.

# CLUB CAR® LIMITED THREE YEAR WARRANTY FOR 2003 INDIVIDUAL GOLF CARS

---

## 1. WARRANTY:

CLUB CAR, INC., ("CLUB CAR") hereby warrants to the Original Retail Purchaser that its new 2003 Model DS golf car purchased from CLUB CAR or an authorized distributor or dealer shall be free from defects in material and workmanship under normal use and service as a golf car for the periods stated below, subject to the provisions, limitations and exclusions contained in this limited warranty.

**LIMITED THREE YEAR WARRANTY:** The golf car frame (excluding the front and rear bumper mounts), rack and pinion steering gearbox unit, suspension system (defined as the shock absorbers, shock mounts, A-plate, leaf springs, shackles, and associated hardware), gasoline engine, unitized transaxle, torque converters (drive and driven), starter generator, transaxle (electric vehicle), and electric motor are warranted with respect to parts and labor for a period of three years from the date of purchase.

**LIMITED TWO YEAR WARRANTY:** All remaining components of the golf car not specified otherwise, except options and accessories, are warranted with respect to parts and labor against defects in material and workmanship for a period of two years from the date of purchase.

**LIMITED ONE YEAR WARRANTY:** All original equipment options and accessories supplied by CLUB CAR are warranted with respect to parts and labor against defects in material and workmanship for a period of one year from the date of purchase.

This limited warranty covers material, workmanship and repair labor cost as to those items specifically listed above for the periods specified. Such repair labor shall be performed only by CLUB CAR, its authorized distributors or dealers, or a service agency approved by CLUB CAR.

IF THE WARRANTY REGISTRATION FORM IS NOT COMPLETED AND RETURNED TO CLUB CAR AT THE TIME OF THE ORIGINAL RETAIL SALE, PURCHASER MUST PROVIDE PROOF OF DATE OF PURCHASE WITH ANY WARRANTY CLAIM.

## 2. EXCLUSIONS:

Excluded from any CLUB CAR warranty are all fuses, filters, decals (except safety decals), spark plugs, light bulbs, lubricants, trim pieces, seats, routine wear items such as the charger plug and receptacle, brake shoes, belts, brushes, bushings, engine mounts, mats and pads, maintenance adjustments, cosmetic deterioration, and items which deteriorate or fail due to exposure or ordinary wear and tear. Batteries, battery charger, onboard computer, and solid-state speed controller are covered under separate CLUB CAR warranties. Also excluded from any CLUB CAR warranty is damage to a golf car or component resulting from a cause other than a defect including unreasonable or unintended strain or use, improper installation of accessories, installation of parts or accessories that are not original equipment, overloading, accident, alteration, abuse or neglect.

Transportation expenses for warranty services are also excluded from this warranty.

## 3. VOIDING OF WARRANTY:

THIS AND ANY OTHER WARRANTY SHALL BE VOID IF THE GOLF CAR IS ABUSED OR USED IN AN UNINTENDED MANNER OR SHOWS INDICATIONS THAT IT HAS BEEN ALTERED IN ANY WAY, INCLUDING, BUT NOT LIMITED TO, MODIFICATION OF THE SPEED GOVERNOR, BRAKING SYSTEM, STEERING, TRANSAXLE, OR OTHER OPERATING SYSTEMS OF THE CAR TO CAUSE IT TO PERFORM OUTSIDE CLUB CAR SPECIFICATIONS. THE WARRANTY IS LIKEWISE VOID IF THE CAR INVOLVED SHOWS INDICATIONS THAT REASONABLE OR NECESSARY MAINTENANCE AS OUTLINED IN THE OWNER'S MANUAL AND MAINTENANCE AND SERVICE MANUAL WAS NOT PERFORMED AT THE TIME AND IN THE MANNER SPECIFIED IN SUCH MANUALS.

## 4. SOLE REMEDY:

CLUB CAR's liability under this limited warranty, or in any action whether based upon warranty, contract, negligence, strict product liability, or otherwise, shall be the repair or replacement, at CLUB CAR's option, of the golf car or component thereof that CLUB CAR deems to be defective. Replacement shall mean furnishing, during the applicable limited warranty period, a new golf car or factory-reconditioned vehicle or component thereof that is identical or reasonably equivalent to the warranted product or component at no cost to the purchaser. Repair shall mean remedying a defect in the golf car or component thereof at no cost to the purchaser during the applicable limited warranty period. If CLUB CAR elects to repair the golf car, it may provide factory-reconditioned parts or components. All parts and components replaced under warranty shall become the property of CLUB CAR.

#### **5. HOW TO MAKE A WARRANTY CLAIM:**

To make a warranty claim under this limited warranty, you must present the golf car or defective component to an authorized CLUB CAR distributor or dealer or send the defective component, freight prepaid, to WARRANTY SERVICES, CLUB CAR, INC., 4125 Washington Road, Evans, Georgia 30809, U.S.A., 706-863-3000.

#### **6. DISCLAIMER:**

**THIS LIMITED WARRANTY IS EXCLUSIVE. CLUB CAR MAKES NO OTHER WARRANTY OF ANY KIND, EXPRESSED OR IMPLIED. ANY IMPLIED WARRANTIES OF MERCHANTABILITY OR FITNESS FOR A PARTICULAR PURPOSE WHICH EXCEED THE OBLIGATIONS OR TIME LIMITS STATED IN THIS WARRANTY ARE HEREBY DISCLAIMED BY CLUB CAR AND EXCLUDED FROM THIS WARRANTY. THE PURCHASER AND CLUB CAR EXPRESSLY AGREE THAT THE REMEDY OF THE REPLACEMENT OR REPAIR OF THE DEFECTIVE GOLF CAR OR COMPONENT THEREOF IS THE SOLE REMEDY OF THE PURCHASER. CLUB CAR MAKES NO OTHER REPRESENTATION OR WARRANTY OF ANY KIND, AND NO REPRESENTATIVE, EMPLOYEE, DISTRIBUTOR OR DEALER OF CLUB CAR HAS THE AUTHORITY TO MAKE OR IMPLY ANY REPRESENTATION, PROMISE OR AGREEMENT, WHICH IN ANY WAY VARIES THE TERMS OF THIS WARRANTY.**

#### **7. NO CONSEQUENTIAL DAMAGES:**

**IN NO EVENT SHALL CLUB CAR BE LIABLE FOR ANY INCIDENTAL OR CONSEQUENTIAL DAMAGES INCLUDING, BUT NOT LIMITED TO, LOSS RELATED TO PROPERTY OTHER THAN THE GOLF CAR, LOSS OF USE, LOSS OF TIME, INCONVENIENCE, OR ANY OTHER ECONOMIC LOSS.**

Some states allow neither limitation on the duration of an implied warranty nor exclusions or limitation of incidental or consequential damages. Therefore, the above limitations or exclusions may not apply to you.

This warranty gives you specific legal rights, and you may also have other rights, which vary from state to state.

#### **8. INFORMATION:**

For further information contact WARRANTY SERVICES, CLUB CAR, INC., P.O. Box 204658, Augusta, Georgia 30917-4658, U.S.A., 706-863-3000.

#### **9. WARNING:**

Any modification or alteration of any golf car beyond factory specifications, including those that affect the weight distribution, stability, or speed of the golf car, can cause serious personal injury or death.



## FOREWORD

---

Thank you for choosing Club Car, the golf car most widely recognized as the industry leader in vehicle efficiency and long-lasting value. You have chosen the finest golf car on the market. Please protect your investment and ensure that your Club Car provides years of reliable, superior performance by reading and following the maintenance instructions in this manual.

Your comfort and safety are important to us as well, so we urge you to read and follow the step-by-step operating instructions and safety precautions in this manual. These instructions must be followed in order to avoid the risk of severe personal injury. If you rent or loan your vehicle to others, we recommend that you ask them to read this manual before they operate the vehicle.

Club Car products are backed by a customer support system designed to offer you fast, courteous service. In the event that your golf car needs repairs or service, we recommend that your local authorized Club Car representative perform them. For the name and address of the Club Car representative nearest you, logon to our web site at [www.clubcar.com](http://www.clubcar.com) or call 1-800-ClubCar (258-2227). If you would prefer to write to us, direct your letter to: Club Car, Attention: Marketing Services, P.O. Box 204658, Augusta, Georgia 30917-4658 USA. Your local authorized Club Car representative can also provide technical advice, parts, and service manuals.

We hope you will consider this owner's manual a permanent part of your golf car. If you sell the vehicle, please include the manual so that the next owner will have the important operating, safety, and maintenance information it contains.

# Practice Safety



Safety signs like you see above may at first seem shocking, but their impact is mild compared with the reality of severe personal injury.

Your safety and satisfaction are of the utmost importance to Club Car. That is why before operating the vehicle, we urge you to review the information in this manual. Understand and become familiar with the DANGER, WARNING and CAUTION statements and procedures it contains, along with the safety decals that are affixed to your vehicle.

Take time to understand the language of safety. It is a language that can save your life.

## PROPOSITION 65 – STATE OF CALIFORNIA

---

### **⚠ WARNING**

This product contains or emits chemicals or substances that have been determined by the state of California to cause cancer and birth defects or other reproductive harm.



## TABLE OF CONTENTS

---

Safety Details . . . . .	8
General Warnings . . . . .	8
Vehicle Feature Identification . . . . .	10
General Information . . . . .	12
Model Identification . . . . .	13
Safety Committee . . . . .	13
Controls and Indicators . . . . .	14
Pre-Operation and Daily Safety Checklist . . . . .	18
Driving Instructions . . . . .	20
Towing . . . . .	22
Transporting on a Trailer . . . . .	22
Storage . . . . .	23
Maintenance . . . . .	24
Periodic Service Schedule . . . . .	24
Periodic Lubrication Schedule . . . . .	26
Vehicle Controller . . . . .	27
Batteries . . . . .	27
Battery Charger . . . . .	29
Cleaning the Vehicle . . . . .	33
Accessories . . . . .	33
Subsequent Owner Registration . . . . .	34
Vehicle Specifications . . . . .	34
Club Car® Limited Three Year Warranty for 2003 Individual Golf Cars . . . . .	36

---

## SAFETY DETAILS

---

### **WARNING**

- **This owner's manual should be read completely before attempting to drive or service the vehicle. Failure to follow the instructions in this manual could result in property damage, severe personal injury, or death.**

It is important to note that some vital statements throughout this manual and on the decals affixed to the vehicle are preceded by the words DANGER, WARNING, or CAUTION. For your protection, we recommend that you take special notice of these safety precautions. Safety precautions are essential and must be followed.

Throughout this manual and on the operation and safety decals affixed to the vehicle, the words "golf car" and "vehicle" are used interchangeably. "Golf car" is defined in the Notice of this manual and no other representation is stated or implied.

If any of the operation or safety decals on the vehicle become damaged, have been removed or cannot be easily read, they should be replaced immediately to avoid possible property damage, personal injury, or death. Contact your Club Car distributor/dealer.

### **DANGER**

- **A DANGER indicates an immediate hazard that will result in severe personal injury or death.**

### **WARNING**

- **A WARNING indicates an immediate hazard that could result in severe personal injury or death.**

### **CAUTION**

- **A CAUTION indicates a hazard or unsafe practice that could result in minor personal injury or product or property damage.**

---

## GENERAL WARNINGS

---

The following safety statements must be heeded whenever the vehicle is being operated, repaired, or serviced. Vehicle feature identification information is also included on pages 10 and 11. Other specific safety statements appear throughout this manual and on the vehicle.

### **DANGER**

- **Battery – Explosive gases! Do not smoke. Keep sparks and flames away from the vehicle and service area. Ventilate when charging or operating vehicle in an enclosed area. Wear a full face shield and rubber gloves when working on or near batteries.**
- **A Club Car vehicle will not provide protection from lightning, flying objects, or other storm-related hazards. If caught in a storm while driving a Club Car vehicle, exit the vehicle and seek shelter in accordance with applicable safety guidelines for your location.**

---

## **▲ WARNING**

- Follow the procedures exactly as stated in this manual, and heed all **DANGER**, **WARNING**, and **CAUTION** statements in this manual as well as those on the vehicle and battery charger.
- Do not leave children unattended on vehicle.
- Prior to leaving the vehicle unattended or servicing the vehicle, turn the key switch **OFF**, remove the key, and place the Forward/Reverse handle or switch in the **NEUTRAL** position. Chock the wheels when servicing the vehicle.
- Improper use of the vehicle or failure to properly maintain it could result in decreased vehicle performance, severe personal injury, or death.
- Any modification or change to the vehicle that affects the stability or handling of the vehicle, or increases maximum vehicle speed beyond factory specifications, could result in severe personal injury or death.
- Check the vehicle for proper location of all vehicle safety and operation decals and make sure they are in place and are easy to read.
- Only trained technicians should service or repair the vehicle or battery charger. Anyone doing even simple repairs or service should have knowledge and experience in electrical and mechanical repair. The appropriate instructions must be used when performing maintenance, service, or accessory installation.
- **IQ System vehicles:**  
Place Tow/Run switch in the **TOW** position before disconnecting or connecting the batteries. Failure to heed this warning could result in a battery explosion or severe personal injury.
- **All electric vehicles:**  
To avoid unintentionally starting the vehicle, disconnect the batteries as shown (Figure 1 and Figure 2).
- **IQ System vehicles:**  
After disconnecting the batteries, wait 90 seconds for the controller capacitors to discharge.
- **PowerDrive System 48 vehicles:**  
After disconnecting the batteries, discharge the controller capacitors as follows:
  - Turn key switch to **ON** and place the Forward/Reverse handle in **REVERSE**.
  - Slowly depress the accelerator pedal and keep it depressed until the reverse warning buzzer can no longer be heard. When the buzzer stops sounding, the controller capacitors are discharged.
- Wear safety glasses or approved eye protection when servicing the vehicle or battery charger. Wear a full face shield and rubber gloves when working on or near batteries.
- Do not wear loose clothing or jewelry such as rings, watches, chains, etc., when servicing the vehicle or battery charger.
- Use insulated tools when working near batteries or electrical connections. Use extreme caution to avoid shorting of components or wiring.

# DS ELECTRIC VEHICLE

## DRIVER / PASSENGER WARNING DECAL

**⚠ WARNING**

**ROLLOVER OR FALLING OFF MAY CAUSE DEATH.**

- Before using vehicle, read operating instructions.
- Remain seated and hold on to seat handle while moving.
- Do not start vehicle until all occupants are seated.
- Two (2) persons per seat maximum.
- Operate from driver side only and not on public roads.
- Keep entire body inside vehicle while moving.
- Drive slowly in turns and straight up and down slopes.
- Do not leave children unattended on vehicle.
- Never operate under the influence of alcohol or drugs.
- Use brakes to reduce speed when coasting downhill.
- Never stand in front of or behind vehicle.

CCI 101960601

**OPERATING INSTRUCTIONS**

- Read Owner's Manual and safety warnings located on dash panel prior to driving.
  - Study and understand controls.
  - Make sure wheels are turned in desired direction.
- Turn key to "ON" position and be sure nothing is in your path.
  - While vehicle is stopped, select direction by placing shift lever or switch in desired position:
    - F - Forward N - Neutral R - Reverse (Buzzer will sound)
- Vehicle will start moving when accelerator pedal is depressed.
- Slowly depress accelerator pedal to increase speed. Park brake will release when accelerator pedal is depressed.
  - To stop, release accelerator pedal and depress brake pedal.
- After stopping the vehicle:
  - Firmly depress park brake until it locks.
  - Place Forward/Reverse switch in "NEUTRAL" position.
  - Turn key "OFF" and remove key when not in use.

CCI 101621601

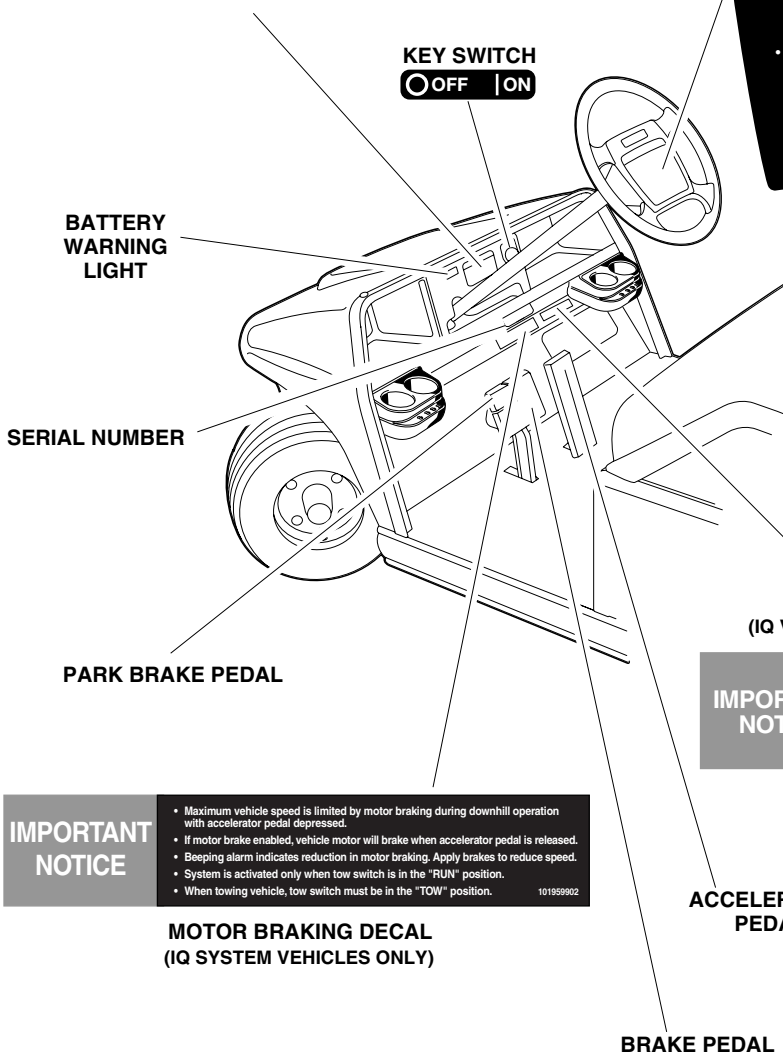

## OPERATING INSTRUCTIONS DECAL

## PRIVATE SPEED DECAL (IQ VEHICLES WITH PRIVATE SPEED OPTION)

**IMPORTANT NOTICE**

This vehicle does not conform to ANSI Z130.1 - "Standard for Golf Cars - Safety and Performance Requirements" because it is capable of speeds in excess of 15 miles per hour. Exercise caution.

CCI 102228701

**IMPORTANT NOTICE**

- Maximum vehicle speed is limited by motor braking during downhill operation with accelerator pedal depressed.
- If motor brake enabled, vehicle motor will brake when accelerator pedal is released.
- Beeping alarm indicates reduction in motor braking. Apply brakes to reduce speed.
- System is activated only when tow switch is in the "RUN" position.
- When towing vehicle, tow switch must be in the "TOW" position.

101959902

## MOTOR BRAKING DECAL (IQ SYSTEM VEHICLES ONLY)

# DS ELECTRIC VEHICLE

**WARNING** HOT RESISTORS (COILED WIRE) CAN CAUSE SEVERE BURNS.

**RESISTOR WARNING DECAL**  
(ON BODY UNDER SEAT ON  
V-GLIDE 36-VOLT VEHICLE)

**ELECTRICAL COMPONENT DECAL**  
(ON SPEED CONTROLLER COVER  
IQ SYSTEM VEHICLE ONLY)

**FORWARD/REVERSE  
HANDLE**  
(POWERDRIVE SYSTEM 48  
AND V-GLIDE 36-VOLT VEHICLES)

**NOTICE**  
Do not operate vehicle without this cover properly installed.  
Do not direct water stream in this area; will cause damage to components.  
See vehicle maintenance and service manual before servicing. CCI 101931501



OR

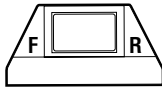

**FORWARD/REVERSE  
SWITCH**  
(IQ SYSTEM  
VEHICLES ONLY)

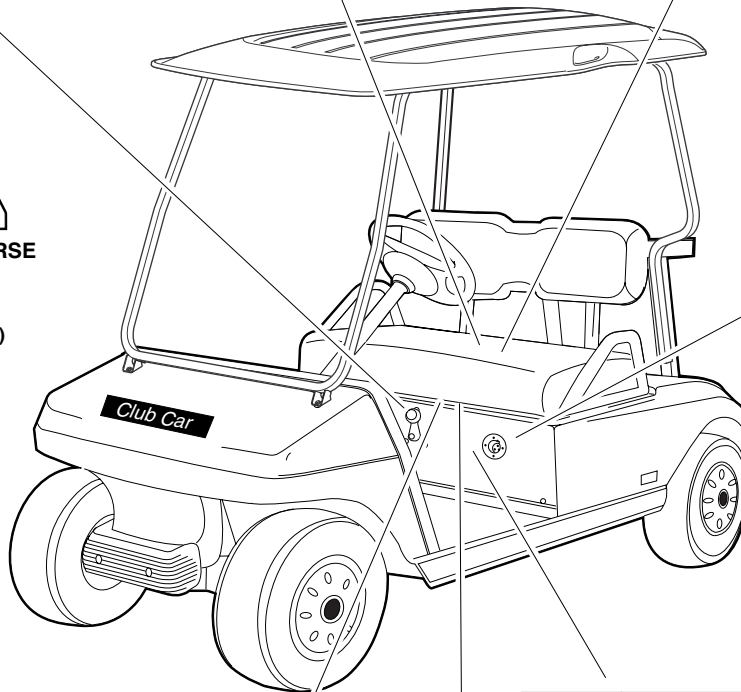

**CHARGER  
RECEPTACLE**

**TOW SWITCH WARNING DECAL**  
(IQ SYSTEM VEHICLES ONLY)  
(ON TOW SWITCH BRACKET UNDER SEAT)

**NOTICE** • DO NOT OPERATE VEHICLE WITHOUT COVER IN PLACE.  
• DO NOT DIRECT WATER STREAM AT THIS SWITCH. CCI 1016109-01

**WARNING** TOW RUN

Place Tow/Run switch in TOW position before:

- Disconnecting or connecting batteries
- Towing
- Extended storage
- Servicing

**FAILURE TO HEED THIS WARNING COULD RESULT IN A BATTERY EXPLOSION OR SEVERE PERSONAL INJURY.**

CCI 101908601

**POTENTIOMETER DECAL**  
(ON WIPER SWITCH COVER INSIDE  
BATTERY COMPARTMENT ON  
WIPER SWITCH VEHICLES ONLY)

**BATTERY DANGER DECAL**  
(ON BODY UNDER SEAT)

**⚠ DANGER / POISON**

<p>EXPLOSIVE GASES CAN CAUSE BLINDNESS OR INJURY</p>	<p>SHIELD EYES</p>	<p>NO SPARKS FLAMES SMOKING</p>	<p>SULFURIC ACID CAN CAUSE BLINDNESS OR SEVERE BURNS</p>	<p>FLUSH EYES IMMEDIATELY WITH WATER GET MEDICAL HELP FAST</p>
--	--------------------	---	--	--

KEEP OUT OF THE REACH OF CHILDREN - DO NOT TIP - KEEP VENT CAPS TIGHT AND LEVEL

## GENERAL INFORMATION

There are three electric DS Golf Car models: the DS V-Glide (36-volt) vehicle, the DS PowerDrive System 48 (48-volt) vehicle, and the DS IQ System (48-volt) vehicle. Throughout this manual, important features unique to each model are highlighted. We urge the owner/operator to read and understand this manual, and to pay special attention to the features specific to his/her vehicle(s).

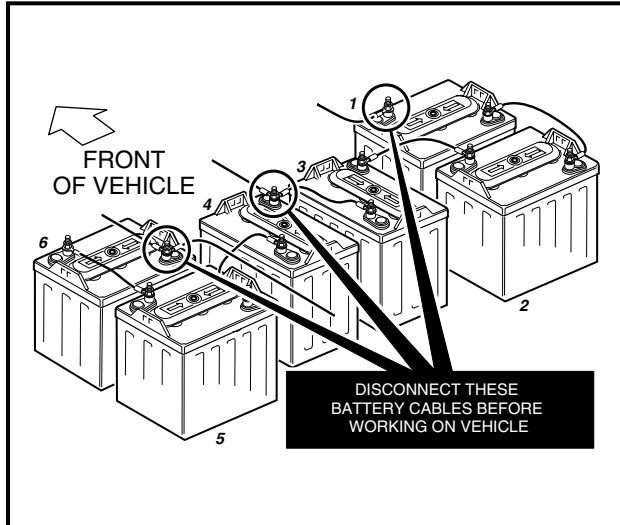

Figure 1 V-Glide 36-Volt Vehicle

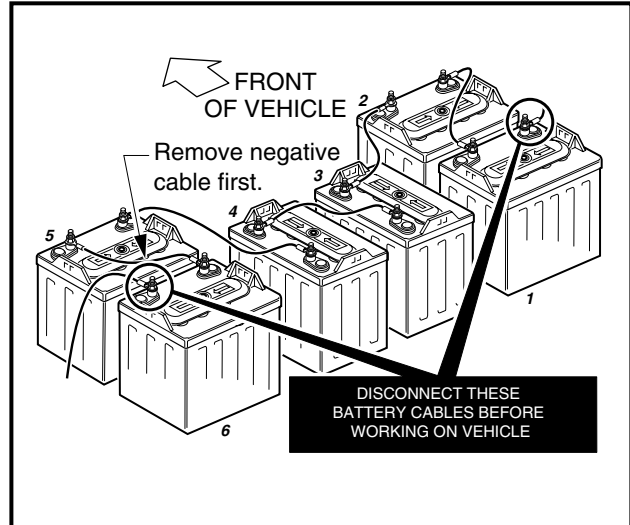

Figure 2 PowerDrive System 48 Vehicle

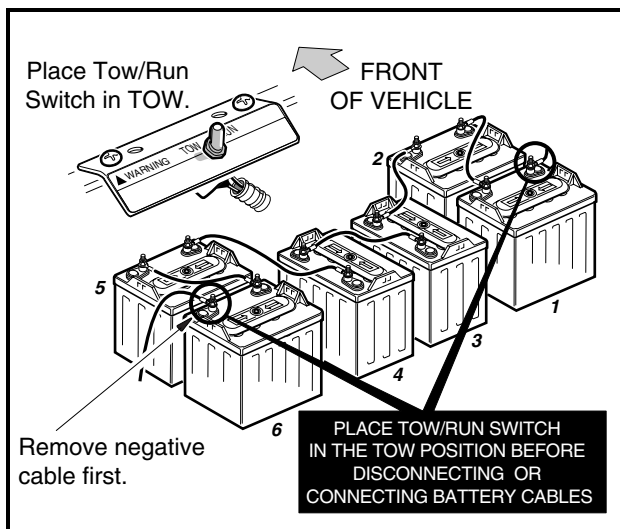

Figure 3 IQ System Vehicle

## MODEL IDENTIFICATION

The serial number of your Club Car is printed on a bar code decal mounted on the frame directly above the accelerator pedal (Example: AQ0301-123456) **(Figure 4)**. There is also a second serial number decal mounted on the front body frame behind the center dash panel. The center dash panel must be removed to view this decal. **See following NOTE.**

**NOTE:** Have the vehicle serial number available when ordering parts or making inquiries.

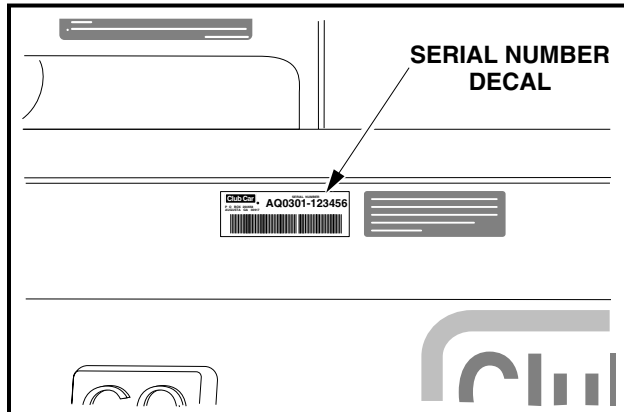

Figure 4 Serial Number Decal

## SAFETY COMMITTEE

If the golf car is to be rented or is part of a fleet, we strongly recommend that a safety committee be appointed. One of the main concerns of this committee should be the safe operation of the golf cars.

This should include at a minimum:

- Where golf cars should be driven.
- Ensuring that proper warnings of driving hazards are displayed and visible.
- Who should and who should not drive golf cars.
- Instructing first time drivers.
- Maintaining golf cars in a safe driving condition.
- How various rules are to be enforced.

The safety committee should include all these items and such others as the committee feels necessary or appropriate.

WARNING SIGN	CCI P/N
Sharp Left	S9911211
Sharp Right	S9921211
Steep Hill	S9931211

## CONTROLS AND INDICATORS

Read **DANGER** and **WARNING** on page 9.

### **⚠ WARNING**

- If renting or loaning the vehicle, make sure the driver is familiar with all controls and operating procedures before allowing the vehicle to be driven.
- Any modification or change to the vehicle that affects the stability or handling of the vehicle, or increases maximum vehicle speed beyond factory specifications, could result in severe personal injury or death.
- Do not shift the Forward/Reverse handle or switch while the vehicle is moving. To avoid injury to an unsuspecting passenger or damage to the vehicle, always bring the vehicle to a full stop before shifting the Forward/Reverse handle or switch.
- Release the accelerator pedal and then depress the brake pedal firmly until the vehicle stops. To avoid unintentionally starting or rolling the vehicle, set the park brake, turn the key switch to OFF, and remove the key when leaving the vehicle.

### KEY SWITCH

The key switch is mounted on the dash to the right of the steering column (**Figure 5**). It has two positions, OFF and ON, which are clearly labeled. **See following NOTE.**

**NOTE:** The key can be removed only when the key switch is in the OFF position.

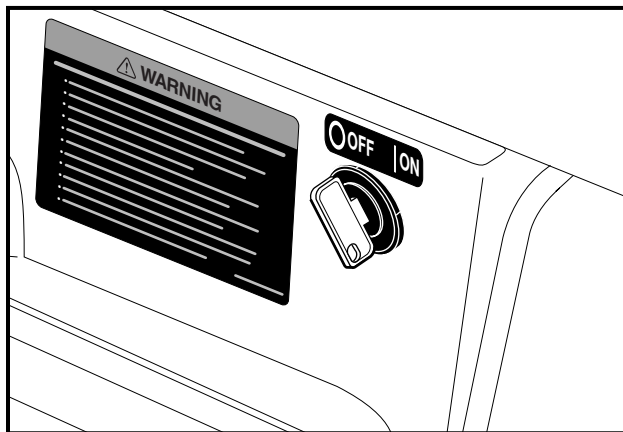

Figure 5 Key Switch

### FORWARD/REVERSE CONTROL

#### DS V-Glide and DS PowerDrive System 48 Vehicles

The Forward/Reverse handle is located on the seat support panel, below and to the right of the driver's right knee (**Figure 6**). The Forward/Reverse handle has three distinct positions: **F** (FORWARD), **R** (REVERSE), and **N** (NEUTRAL). Rotate the handle towards the driver (FORWARD) to operate the vehicle in the forward direction, or towards the passenger (REVERSE) to operate vehicle in reverse. When the handle is in the straight up position (NEUTRAL), vehicle will not operate. Club Car vehicles operate at reduced speed in reverse. The reverse buzzer will sound as a warning when the Forward/Reverse handle is in REVERSE.



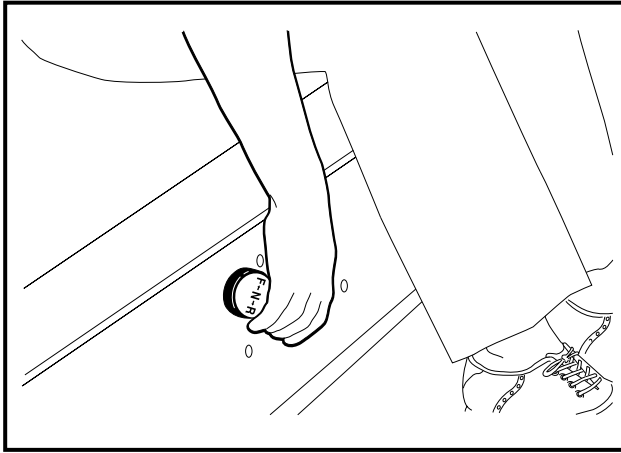

Figure 6 Forward/Reverse Handle

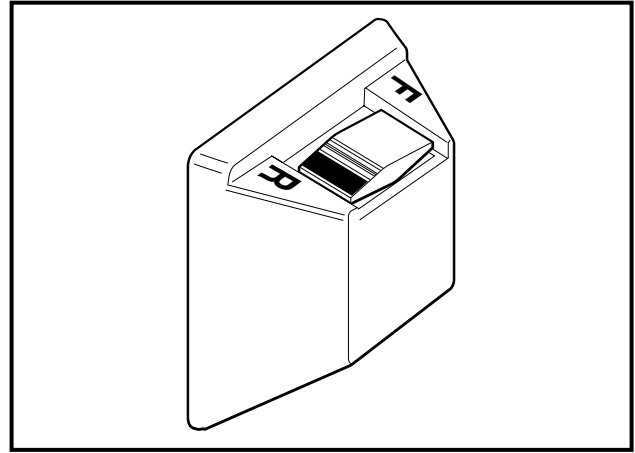

Figure 7 Forward/Reverse Rocker Switch

## DS IQ System Vehicles

The Forward/Reverse rocker switch is located in the same place as the Forward/Reverse handle on all other DS models: on the seat support panel below and to the right of the driver's right knee. The **F** (FORWARD) and **R** (REVERSE) positions are clearly marked. Push down the FORWARD side of the switch to operate the vehicle in the forward direction, or push down the REVERSE side of the switch to operate the vehicle in reverse. When the rocker switch is positioned in NEUTRAL, with neither side down, the vehicle will not operate if the accelerator pedal is depressed (**Figure 7**). The reverse buzzer will sound as a warning when the Forward/Reverse switch is in REVERSE.



Figure 8 Accelerator and Brake Pedals

## ACCELERATOR PEDAL

The accelerator pedal is the pedal on the right, with the word **GO** molded into it (**Figure 8**). The operation of the accelerator pedal differs from that of an automobile. When the key switch is ON, and the Forward/Reverse handle or switch is in either FORWARD or REVERSE, depressing the accelerator pedal will automatically release the park brake and start the vehicle moving in the direction selected (forward or reverse). As the accelerator pedal is depressed, speed will increase until full speed is reached. When the accelerator is released, power will be cut off and the motor will stop running.

**IQ System vehicles only:** See “pedal-up” and “pedal-down” motor braking on page 19.

## BRAKE PEDAL

The brake pedal is the large pedal on the left with the word STOP molded into it (**Figure 8**). To slow or stop the vehicle, depress the brake pedal with your foot (**Figure 9**).



Figure 9 Brake Pedal

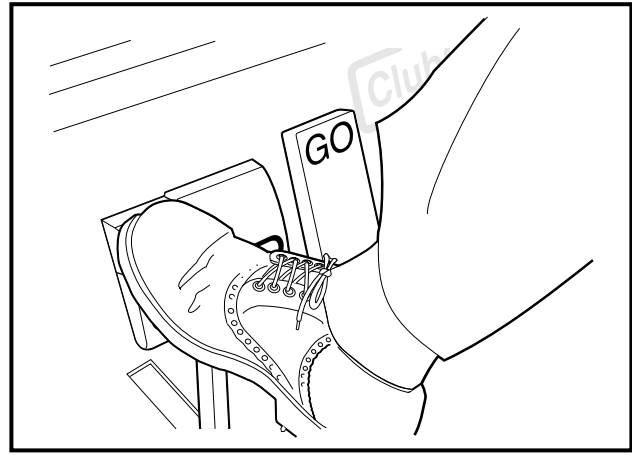

Figure 10 Park Brake Pedal

## PARK BRAKE PEDAL

The park brake pedal is the small raised portion in the upper left corner of the brake pedal. It has the word PARK molded into it and the words PARK BRAKE marked on top of it (**Figure 9**). To set the park brake, depress the brake pedal firmly and tilt the park brake portion of the pedal forward with your foot (**Figure 10**). See following **WARNING**.

### **⚠ WARNING**

- The park brake will release automatically when either the accelerator or brake pedal is depressed. The park brake has multiple locking positions and should be firmly pressed and locked to prevent the vehicle from rolling.

## BATTERY WARNING LIGHT

### PowerDrive System 48 and IQ System Electric Vehicles Only

PowerDrive System 48 and IQ System vehicles feature a dash-mounted warning light (above steering column) that, when the vehicle is in operation, indicates low battery voltage or, when the vehicle is being charged, indicates a charging problem. The battery warning light is controlled by the onboard computer.

When the vehicle is in operation, the warning light will illuminate and remain illuminated if:

- Batteries voltage drops below 48 volts when there is no load on the batteries (the vehicle is stopped and there are no accessories on).
- Batteries have discharged to less than 25% of rated capacity.

If the warning light illuminates when the vehicle is operating, there will be enough power remaining to drive the vehicle for approximately 30 minutes. However, the vehicle should be charged at the first opportunity. If the warning light illuminates and the vehicle is unable to operate for 30 minutes, have your Club Car distributor/dealer check the vehicle for a possible battery or electrical system problem.

When the batteries receive an incomplete charge because 1) the DC power cord is disconnected, 2) AC power to the charger is interrupted, 3) automatic charger shut-off occurs after 16 hours of operation, or 4) the charger malfunctions, the warning light will indicate as follows:

- The warning light will not illuminate if the charge is 90% or more complete. The onboard computer will retain in memory the amount of charge needed to fully replenish the batteries and will complete the charge during the next charge cycle.
- When the charger is unplugged, the warning light will illuminate and remain illuminated for 10 seconds if the charge is less than 90% complete but the vehicle has enough power for approximately 30 minutes of operation. This will alert the operator that the vehicle may be used, but that it must be charged to completion as soon as possible.
- The warning light will repeatedly illuminate for 10 seconds, with 4 second intervals if the charger times out at 16 hours and the batteries are not sufficiently charged. **See PowerDrive Owner's Manual.** This indicates an abnormal charge cycle. The charger and batteries should be checked by your Club Car distributor/dealer.
- The warning light will repeatedly illuminate for 10 seconds, with 4 second intervals during a charge cycle (DC plug is still connected) if AC power to the charger is interrupted. The light will go out when AC power is restored.

**LED Light:** In addition to the warning light, there is an infrared LED in the dash light assembly, which transmits an infrared signal from the onboard computer (OBC). This signal is received by the optional Communication Display Module, which provides information on the condition of the vehicle and batteries.

## TOW/RUN SWITCH

### IQ System Vehicles Only

#### **▲ WARNING**

- **Place Tow/Run switch in the TOW position before disconnecting or connecting the batteries. Failure to heed this warning could result in a battery explosion or severe personal injury.**
- **When the Tow/Run switch is in the TOW position, all motor braking functions, including zero-speed detect, are disabled.**

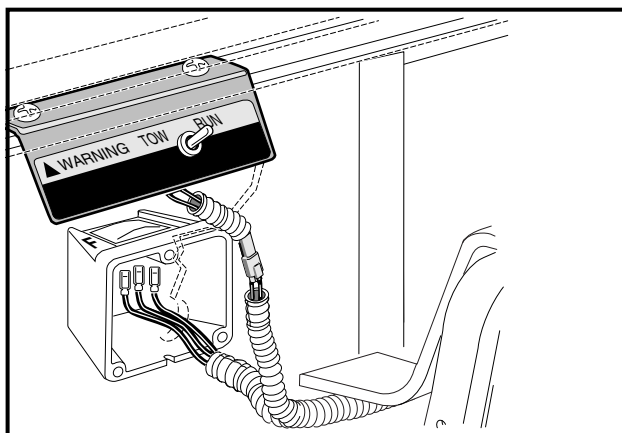

Figure 11 Tow/Run Switch

DS IQ System vehicles are equipped with a Tow/Run switch, located under the seat just above the Forward/Reverse switch (**Figure 11**). The switch must be in the RUN position in order to operate the vehicle. When the switch is in the TOW position, power to the vehicle electrical components is turned off and the vehicle will not operate. **See following NOTE.**

**NOTE:** After placing the Tow/Run switch in the TOW position, allow 10 seconds to elapse before switching back to the RUN position.

After placing the Tow/Run switch in RUN position, allow 10 seconds to elapse before operating the vehicle.

The Tow/Run switch should be placed in the TOW position under the following conditions:

- **Before Towing the Vehicle:** Place the Tow/Run switch in the TOW position to disable all motor braking functions, thus preventing possible damage that could occur to the vehicle or electrical components if the vehicle is towed while the Zero-Speed Detect motor braking function is operating.
- **Before Disconnecting or Connecting Battery Cables:** Place the Tow/Run switch in the TOW position to turn off power to the vehicle electrical system, thus preventing severe arcing and possible battery explosion as the battery cables are disconnected.
- **For Long Term Storage:** Place the Tow/Run switch in the TOW position to turn off power to the vehicle electrical system, thus preventing vehicle electrical components from discharging the batteries.

## PRE-OPERATION AND DAILY SAFETY CHECKLIST

Each Club Car vehicle has been thoroughly inspected and adjusted at the factory; however, upon receiving your new vehicle(s), you should become familiar with its controls, indicators, and operation. Carefully inspect each vehicle to ensure that it is in proper working condition before accepting delivery.

Use the following checklist as a guide to inspect the vehicle. This checklist should be used daily to ensure that the vehicle is in proper working condition and in conjunction with the Periodic Service Schedule on page 25. Any problems should be corrected by a Club Car distributor/dealer or a trained technician.

- **General:** All the parts should be in place and properly installed. Be sure that all nuts, bolts, and screws are tight.
- **Safety and information decals:** Check to ensure that all safety and information decals are in place. **See pages 10 and 11.**
- **Tires:** Check for proper tire pressure on your new vehicle. **See Vehicle Specifications on page 34.** Visually inspect tires for wear, damage, and proper inflation on a daily basis.
- **Batteries:** Check electrolyte to ensure that it is at its proper level (**Figure 13, Page 28**). Check battery posts. Wires should be tight and free of corrosion. Charge batteries fully before first use of vehicle.
- **Charger cord, plug, and receptacle:** Visually inspect for cracks, loose connections, and frayed wiring. **See Plug and Receptacle on page 32.**
- **Wiper switch (for V-Glide 36-volt vehicles):** Be sure wiper switch cover is properly secured prior to operating the vehicle.

### **WARNING**

- **Be sure the plastic has been removed from the seat bottom before operating the vehicle. Failure to do so may result in a fire, property damage, personal injury, or death.**

## PERFORMANCE INSPECTION

After you have familiarized yourself with the vehicle controls and have read and understood the driving instructions, take the vehicle for a test drive.

Use the following checklist as a guide to inspect the vehicle and check daily for proper operation. Any problems should be corrected by a Club Car distributor/dealer or a trained technician.

### All Vehicles

- **Forward/Reverse switch:** Check for proper operation. **See Controls and Indicators on page 14.**
- **Brakes:** Be sure the brakes function properly. When brake pedal is fully depressed under moderate pressure, it should not go more than halfway to the floor, and vehicle should come to a smooth, straight stop within 14 feet (4.3 m). If the pedal goes more than halfway to the floor, or if the vehicle swerves or fails to stop within 14 feet (4.3 m), have the brake system checked and adjusted as required. Brake adjustment must be maintained so that the brake pedal cannot be depressed to the floor under any circumstance.
- **Park brake:** When latched, the park brake should lock the wheels and hold the vehicle stationary (on an incline of 20% or less). It should release when either the accelerator or brake pedal is depressed.
- **Reverse buzzer:** The reverse buzzer will sound as a warning when the Forward/Reverse handle or switch is in REVERSE.
- **Steering:** The vehicle should be easy to steer and should not have any play in the steering wheel.
- **Accelerator:** With the key switch ON and the Forward/Reverse switch in the FORWARD position, as the accelerator pedal is depressed, the motor should start and the vehicle should come up smoothly to full speed. When the pedal is released it should return to the original position and the motor should rotate freely. All Club Car vehicles operate at reduced speed in reverse.

**IQ System vehicles only:** When the pedal is released it should return to the original position and the motor should rotate freely or go into motor braking mode. **See "Pedal Up" Motor Braking below.**

- **General:** Listen for any unusual noises such as squeaks or rattles. Check the vehicle's ride and performance. Have a Club Car distributor/dealer or a trained technician investigate anything unusual.

### DS IQ System Vehicles

- **Zero Speed Detect:** With the vehicle parked on level ground and the park brake disengaged, place the Tow/Run switch in the RUN position and attempt to push the vehicle. Motor braking should engage and cause resistance to rolling (moving at no more than 1 to 3 mph) (1.5 or 4.8 km/h) with the Forward/Reverse switch in any position. When zero speed detect motor braking is engaged, the reverse buzzer should emit a distinct pattern of beeps.
- **"Pedal Up" Motor Braking (adjustable on IQ System vehicles):** Accelerate the vehicle to full speed and then release the accelerator pedal. Motor braking should quickly and smoothly slow the vehicle to approximately 11 mph (17.7 km/h). Motor braking will disengage when vehicle slows to 11 mph (17.7 km/h). This feature is adjustable for IQ System vehicles only. Contact your local Club Car dealer/distributor to inquire about this adjustable feature.
- **"Pedal Down" Motor Braking:** Accelerate down an incline with the accelerator pedal depressed. When the vehicle reaches maximum designed speed, motor braking should engage and limit the vehicle to its maximum designed speed. On very steep grades, the vehicle may slightly exceed its maximum designed speed, requiring use of the brake pedal.

---

## DRIVING INSTRUCTIONS

---

### **WARNING**

- Only licensed drivers should be allowed to drive the vehicle.
- If renting or loaning the vehicle, make sure the driver is familiar with all controls and operating procedures before allowing the vehicle to be driven.
- No more than two people should be on the vehicle at one time.
- The vehicle is not specially equipped for handicapped persons:
  - Be sure all persons can properly operate the vehicle prior to allowing them to drive the vehicle.
  - Be sure all passengers are capable of securing themselves in a vehicle before allowing them to ride in one.
- For night use, the vehicle must be equipped with headlights, taillights and reflectors.
- Stop the vehicle before shifting the Forward/Reverse switch. Failure to do so may result in injury to an unsuspecting passenger and (or) damage to the vehicle.
- To help avoid being struck, do not stand in front of or behind the vehicle.
- Operate the vehicle from the driver seat only.
- To help prevent falls from the vehicle, remain seated in a moving vehicle and hold on to seat handles or handrails at all times. Driver should keep both hands on the steering wheel when the vehicle is in motion.
- To help prevent the possibility of serious injury, keep your entire body inside the vehicle.
- Do not leave children unattended on vehicle.
- To help prevent overturning the vehicle, drive slowly straight up and down slopes. Avoid driving the vehicle on slopes exceeding 20% incline.
- To help avoid possible injury to an inattentive passenger and (or) damage to the vehicle, avoid sudden starts, sudden stops, and abrupt turns.
- To help avoid the possibility of losing control of or overturning the vehicle, reduce speed for adverse driving conditions such as wet grass or rough terrain.
- Do not use the vehicle on public roads. It is not designed or intended for street use and should not be licensed for use on public roads.
- Obey all local rules concerning golf cars.
- The vehicle should be driven in only specified areas by trained drivers.
- Do not drive while under the influence of alcohol, drugs, or medications.
- To prevent overturning the vehicle, drive slowly in turns.
- Use brakes to reduce speed when coasting downhill.

No one should drive the vehicle without first being instructed in the proper operation and use of the vehicle's controls. An experienced operator should accompany each first-time driver on a test drive before allowing him/her to operate the vehicle alone.

To ensure safe operation of the vehicle, follow exactly and in order, all of the following procedures. Read and understand all instructions prior to driving the vehicle.

## STARTING THE VEHICLE

1. Study and understand controls.
2. Make sure everyone is seated and holding onto seat handles or handrails.
3. Read safety warnings located on dash and (or) above pedals.
4. Make sure wheels are turned in desired direction.
5. Turn key to the ON position and make sure nothing is in your path.
6. Select direction by placing Forward/Reverse handle or switch in desired position (F = forward or R = reverse). A buzzer will sound as a warning when the Forward/Reverse handle or switch is in REVERSE.
7. Slowly depress accelerator pedal. The park brake will release automatically and the vehicle will start to move. As the accelerator pedal is depressed, speed will increase until full speed is reached. **See following WARNING.**

### **WARNING**

- Operator must control vehicle speed when going downhill.
- **IQ System vehicles only:** “Pedal down” or “pedal up” motor braking may be used to help control speed when going downhill; however, steep terrain or other conditions may require that pedal braking be used in conjunction with motor braking.

## STOPPING THE VEHICLE

### **WARNING**

- Driving through water may affect the brakes. After driving through water, check effectiveness of the brakes by gently depressing the brake pedal. If the vehicle does not slow down at the normal rate, continue to depress the brake pedal until the brakes dry out and normal performance returns.

### **CAUTION**

- When stopped on a hill, use the brake pedal to hold your position. Do not use the accelerator pedal.

To stop the vehicle, release the accelerator pedal and depress the brake pedal with your right foot until the vehicle comes to a complete stop.

## PARKING AND LEAVING THE VEHICLE

1. After stopping the vehicle, firmly depress the park brake pedal until it locks. This will prevent the vehicle from rolling.
2. Turn the key switch to OFF and place the Forward/Reverse handle or switch in the NEUTRAL position. Remove the key when the vehicle is not in use.
3. **IQ System vehicles only:** When the Tow/Run switch is in the RUN position, (with the Forward/Reverse switch or key switch in any position), the “zero speed detect” function will prevent the vehicle from rolling at more than 1 or 3 mph (1.5 or 4.8 km/h) unless the accelerator is depressed. This prevents the possibility of a parked vehicle (with the park brake disengaged) rolling away too fast to be overtaken on foot. **See Zero Speed Detect on page 19.**

---

## TOWING

---

### **WARNING**

- Do not tow the vehicle on public streets or highways.
- Use only approved Club Car tow bars.
- Turn the key switch to OFF and place the Forward/Reverse handle or switch in NEUTRAL before towing the vehicle.
- Extreme caution should be used when towing any vehicle.
- Do not exceed 5 mph (8 km/h) towing speed.
- Do not allow people in the vehicles being towed.
- Avoid sudden starts, sudden stops, and tight turns when towing.
- Avoid stopping on a hill when towing. If you must stop on a hill, avoid sudden starts or rolling backwards and stopping suddenly. Failure to heed this warning could cause the vehicle to overturn, possibly resulting in severe personal injury.
- Do not tow more than one Club Car vehicle with another Club Car vehicle. If more than one vehicle must be towed, an adequately powered vehicle (tractor or full sized truck) properly fitted, with a tow hitch height of 11 inches (28 cm) should be used. Only heavy-duty tow bars should be used for multi-vehicle towing. Never tow more than five vehicles at one time.
- IQ System vehicles only: Place the Tow/Run switch in TOW position; otherwise, the vehicle will not roll while being towed.

All vehicles are equipped with both front and rear tow bar attaching points. A light duty tow bar is available for break-down towing and single vehicle towing. A heavy duty tow bar and an onboard tow bar are available for multi-vehicle towing. Observe all of the previous WARNING statements when towing.

---

## TRANSPORTING ON A TRAILER

---

### **WARNING**

- For use on public roads, the trailer must meet all federal, state, and local requirements such as taillights, brake lights, etc.
- Do not tow a Club Car vehicle behind a passenger vehicle or truck on a public road unless it is on an approved trailer.
- The vehicle to be towed should be tied securely to the trailer, with the Forward/Reverse handle or switch in NEUTRAL, the key switch OFF, and the park brake firmly depressed and locked.
- Do not allow people in the trailer or vehicle being towed.
- Avoid sudden starts, sudden stops, and tight turns when towing.
- Avoid stopping on a hill when towing. If you must stop on a hill, avoid sudden starts or rolling backwards and stopping suddenly. Failure to heed this warning could cause the vehicle to overturn, possibly resulting in severe personal injury.
- When towing on a trailer, normal road speed of the tow vehicle should be reduced.
- Because of the added length of the trailer, caution should be used when turning a corner.
- Remove the vehicle windshield before transporting on a trailer.

If the vehicle must be transported over long distances or on public highways, it should be transported on an approved trailer that has the approved load rating of 1200 lb. (544 kg) per vehicle being transported.

**NOTE:** A two-car trailer should be rated at  $2 \times 1200 = 2400$  lb. ( $2 \times 544 = 1088$  kg).



---

## STORAGE

---

Read **DANGER** and **WARNING** on page 10.

### **⚠ WARNING**

- Turn the key switch **OFF**, remove the key, and leave the **Forward/Reverse** handle or switch in the **NEUTRAL** position during storage. This is to prevent unintentionally starting the vehicle or a fire hazard.
- Do not attempt to charge frozen batteries or batteries with bulged cases. Discard the battery. Frozen batteries can explode.

### **⚠ CAUTION**

- Batteries in a low state of charge will freeze at low temperatures.
- When washing the vehicle, do not direct water stream at the accelerator switch, Forward/Reverse switch, or other electrical component.
- **IQ System vehicles only:** Place Tow/Run switch in **TOW** position.

## PREPARING THE VEHICLE FOR EXTENDED STORAGE

1. Fully charge batteries. **See Charging Batteries on page 30.**
2. Batteries should be clean and free of corrosion. Wash tops and terminals of batteries with a solution of baking soda and water (1 cup (237 mL) baking soda per 1 gallon (3.8 L) of water). Rinse solution off batteries. Do not allow this solution to enter the batteries. Be sure terminals are tight. Let the terminals dry and then coat them with Battery Terminal Protector Spray (CCI P/N 1014305).
3. Store vehicle in a cool, dry place. This will minimize battery self-discharge.
4. Adjust tires to recommended tire pressure. **See Vehicle Specifications on page 34.**
5. Lubricate front suspension and do all other semiannual periodic lubrication. **See Periodic Lubrication Schedule on page 26.**
6. Thoroughly clean front body, rear body, seats, battery compartment, and underside of vehicle.
7. Do not engage the park brake. Chock the wheels to prevent the vehicle from rolling.
8. Keep batteries fully charged during storage.
  - **PowerDrive Chargers:** Leave PowerDrive Chargers plugged in during storage. The onboard computer will automatically activate the charger when necessary. If charger cannot remain plugged in, or AC power will not be available during extended storage, disconnect the batteries for storage (**Figure 2, Page 12**).
  - **Accu-Power Chargers only:** Charge batteries every six to eight weeks. If it is not possible to charge the batteries every six to eight weeks, disconnect the batteries for storage (**Figure 2, Page 12**).

---

## RETURNING THE STORED VEHICLE TO SERVICE

1. If necessary, connect batteries.
2. Fully charge batteries.
3. Adjust tires to recommended tire pressure. **See Vehicle Specifications on page 34.**
4. Perform the Pre-Operation and Daily Safety Checklist on page 18.

---

## MAINTENANCE

---

### Read DANGER and WARNING on page 9.

To ensure trouble-free vehicle performance, it is very important to follow an established preventive maintenance program. Regular and consistent vehicle maintenance can prevent vehicle downtime and expensive repairs that can result from neglect. Use the Pre-Operation and Daily Safety Checklist on page 18 and the following Periodic Service Schedule and Periodic Lubrication Schedule to keep the vehicle in proper working condition.

Any vehicle not functioning correctly should be removed from use until it is properly repaired. This will prevent further damage to the vehicle and avoid the possibility of injury due to unsafe conditions.

Contact your local Club Car distributor/dealer to perform all repairs and semiannual and annual periodic service.

### **WARNING**

---

- **If any problems are found during scheduled inspection or service, do not operate the vehicle until repairs are made. Failure to make necessary repairs could result in fire, property damage, severe personal injury, or death.**
- **Hot! Do not attempt to service hot motor or resistors. Attempting to do so could cause severe burns.**

---

## PERIODIC SERVICE SCHEDULE

---

### **WARNING**

---

- **Service, repairs, and adjustments must be made per instructions in the maintenance and service manual.**

**NOTE:** If the vehicle is constantly subjected to heavy use or severe operating conditions, the preventive maintenance procedure should be performed more often than recommended in the periodic service and lubrication schedules.

Both the Periodic Service Schedule and Periodic Lubrication Schedule must be followed to keep vehicle in optimum operating condition.

PERIODIC SERVICE SCHEDULE		
REGULAR INTERVAL	SERVICE	
Daily service by owner	Batteries	Charge batteries (after each use only).
Weekly service by owner	Batteries	Check electrolyte level. Add water if necessary. <b>See page 28.</b>
Monthly service by owner or trained technician	Batteries	Wash battery tops and clean terminals with baking soda/water solution.
	Tires	Check air pressure and adjust if necessary. <b>See Vehicle Specifications on page 34.</b>
	Wiper switch (V-Glide 36-volt vehicle only)	Check for cracks or other damage; make sure switch is securely fastened to frame. Check moveable contact for correct operation.
	General vehicle	Wash battery compartment and underside of vehicle.
Semiannual service by trained technician only (every 50 hours of operation or 100 rounds of golf)	Brake system	Check brake shoes; replace if necessary. <b>See Section 6 – Wheel Brake Assemblies in the appropriate maintenance and service manual.</b>
		Lubricate brake slides per Lubrication Schedule. <b>See Section 6 – Wheel Brake Assemblies in the appropriate maintenance and service manual.</b>
		Check brake cables for damage; replace if necessary.
	Electrical wiring and connections	Check for tightness and damage.
	Forward/Reverse switch	Check condition of contacts and wire connections. Make sure connections are tight.
	Front wheel alignment and camber	Check and adjust as required. <b>See Section 7 – Steering and Front Suspension in the appropriate maintenance and service manual.</b>
	Motor controller output regulator (MCOR)	Check for loose hardware, cracks and other damage.
Annual service by trained technician only (every 100 hours of operation or 200 rounds of golf)	Batteries	If batteries are not performing as expected, see Section 13 – Batteries in the appropriate maintenance and service supplement.

** WARNING**

- If any problems are found during scheduled inspection or service, do not operate the vehicle until repairs are made. Failure to make necessary repairs could result in fire, property damage, severe personal injury, or death.

## PERIODIC LUBRICATION SCHEDULE

PERIODIC LUBRICATION SCHEDULE			
REGULAR INTERVAL	SERVICE	LUBRICATION POINT	RECOMMENDED LUBRICANT
Semiannually by owner or trained technician (every 50 hours of operation or 100 rounds of golf)	Brake pedal shaft bearings	1	Dry Moly Lube (CCI P/N 1012151)
	Brake linkage and pivots	2	Dry Moly Lube (CCI P/N 1012151)
	Accelerator rod pivots and mounts (V-Glide only) Accelerator pivot rod supports (PowerDrive and IQ System)	3	Dry Moly Lube (CCI P/N 1012151)
	Charger receptacle (all vehicles) Forward/Reverse switch contacts (V-Glide and PowerDrive only)	4	WD-40
	Brake slides	5	Dry Moly Lube (CCI P/N 1012151)
	Front suspension (5 fittings)	6	Chassis Lube – EP NLGI Grade 2
Annually by trained technician only (every 100 hours of operation or 200 rounds of golf)	Check/fill transaxle to plug level	7	22 oz. (0.67 liters) SAE 30 WT. API Class SE, SF, or SG Oil (or higher)
	* Repack tapered front wheel bearings. (Sealed bearings require no lubrication.)	8	Chassis Lube – EP NLGI Grade 2

\* Tapered front wheel bearings are provided with a chrome metal bearing cap. Sealed ball bearing front wheel bearings are provided with a black plastic bearing cap.

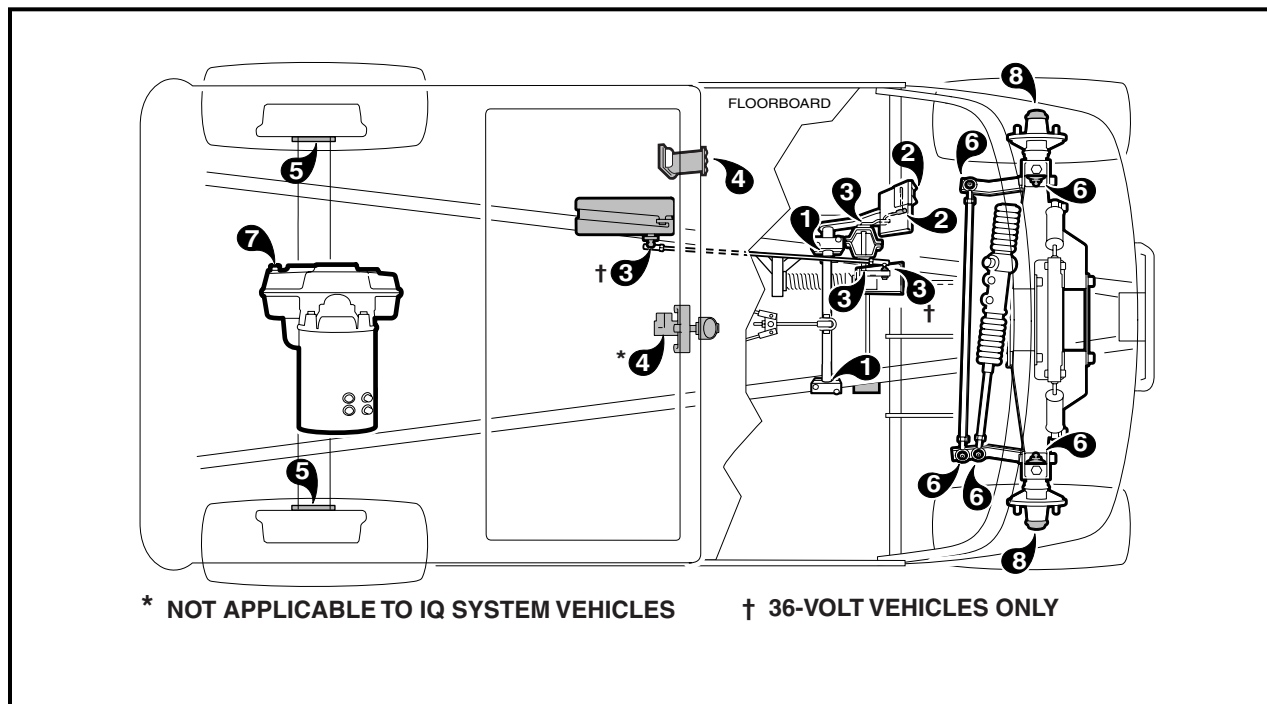

Figure 12 Lubrication Points

---

## VEHICLE CONTROLLER

---

The DS electric vehicle is equipped with either a solid state speed controller (PowerDrive System 48 and IQ System), or a V-Glide speed controller (36-volt vehicle). In order to properly service and maintain the solid state controller vehicle or the V-Glide speed controller vehicle, it is necessary to understand the electrical circuitry and the functions of all components in both systems. Therefore, if any repair or servicing needs to be performed, we recommend that it be performed by an authorized Club Car distributor/dealer using Club Car OEM parts.

---

## BATTERIES

---

Read **DANGER** and **WARNING** on page 9.

### **DANGER**

---

- **Battery – Explosive gases! Do not smoke. Keep sparks and flames away from the vehicle and service area. Ventilate when charging or operating vehicle in an enclosed area. Wear a full face shield and rubber gloves when working on or near batteries..**
- **Charge batteries in a well-ventilated area only. Batteries emit hydrogen while being charged. Hydrogen is an explosive gas and must never exceed a level of 2% of the air.**
- **Battery – Poison! Contains acid! Causes severe burns. Avoid contact with skin, eyes, or clothing. Antidotes:**
  - **External: Flush with water. Call a physician immediately.**
  - **Internal: Drink large quantities of milk or water followed with milk of magnesia or vegetable oil. Call a physician immediately.**
  - **Eyes: Flush with water for 15 minutes. Call a physician immediately.**

### **WARNING**

---

- **Wear safety glasses or approved eye protection when servicing the vehicle or battery charger. Wear a full face shield and rubber gloves when working on or near batteries.**
- **Use insulated tools when working near batteries or electrical connections. Use extreme caution to avoid shorting of components or wiring.**

### **CAUTION**

---

- **On all vehicles, turn off all accessories before charging batteries.**

**NOTE:** *Recycle or dispose of discarded batteries in accordance with local, state, and federal regulations.*

- The batteries in DS V-Glide 36-Volt electric vehicles are 6 volts each.
- The batteries in PowerDrive System 48 and IQ System electric vehicles are 8 volts each.

Both the 6- and 8-volt batteries are deep-cycle batteries, specially built for electric vehicle application. Automotive batteries should never be used.

New batteries will not deliver their full capabilities until they have been discharged and recharged 20 to 50 times. To obtain the maximum service life from new batteries, restrict PowerDrive System 48 and IQ System vehicles with new batteries to 36 holes of use between charges in the first two months of operation; V-Glide 36-volt vehicles should be limited to 18 holes between charges in the first two months. Batteries should be fully charged before first use of new vehicle, before first use of a vehicle after storage, and before releasing vehicle for use each day.

## BATTERY CARE

To keep batteries in good working condition, follow this maintenance program on a regular basis:

1. The batteries should be kept clean and free of corrosion. Wash tops and terminals of batteries with a solution of baking soda and water (1 cup (237 mL) baking soda per gallon (3.8 L) of water). Rinse solution off of the batteries. Do not allow this solution to enter the battery. Be sure terminals are tight. Let the terminals dry and then coat with Battery Terminal Protector Spray (CCI P/N 1014305). **See following NOTE.**

**NOTE:** *Dispose of waste water properly.*

2. The electrolyte level in the batteries should be checked weekly (**Figure 13**). Add water only after charging unless the electrolyte level is below the top of the plates. In this case, add just enough water to cover the plates, charge and then check the level again. Never charge batteries if plates are exposed above electrolyte level. For best battery life, add only distilled water. **See following NOTE.**

**NOTE:** *A battery watering gun or bottle is available at many auto parts dealers.*

3. The hold-down straps should be tight enough so that the batteries do not move while the vehicle is in motion, but not so tight as to crack or buckle the battery case. Tighten hold-down retaining nuts to 40 in-lb (4.5 N·m). The terminal connections should be clean and tight, and any worn insulation or frayed wires should be replaced. Tighten battery terminals to 110 in-lb (12.4 N·m). **See following CAUTION.**

### **⚠ CAUTION**

- If battery wire terminals are damaged or corroded, they should be replaced or cleaned as necessary. Failure to do so may cause them to overheat during operation.
4. After use, the batteries should be placed on charge. The batteries should never be left discharged any longer than absolutely necessary (do not leave discharged overnight).

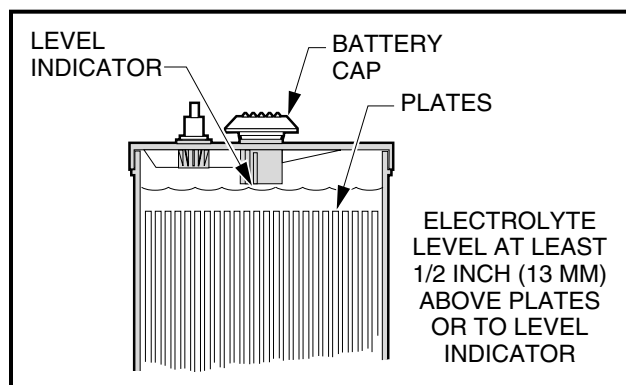

**Figure 13 Battery Electrolyte Level**

---

## BATTERY CHARGER

---

### **⚠ DANGER**

- The charging area must be ventilated. Hydrogen level in the air must never exceed 2%. The total volume of air in the charging area must be changed five times per hour. Exhaust fans should be located at the highest point of the roof. Contact a local HVAC engineer.
- Do not charge the vehicle batteries with the vehicle covered or enclosed. Any enclosure or cover should be removed or unzipped and pulled back when batteries are being charged. An accumulation of hydrogen gas could result in an explosion.

### **⚠ WARNING**

- Only trained technicians should repair or service the charger. Contact your nearest Club Car distributor/dealer.
- Each charger should have its own dedicated 15 or 20 ampere separately protected (circuit breaker or fuse) single phase branch circuit, in accordance with all applicable electrical codes for the location.
- Connect the charger AC supply cord to a properly grounded, three-wire outlet of the proper voltage and frequency as shown on the charger.
- Do not use an adapter to plug the charger with a three-prong plug into a two-prong outlet. Improper connection of the equipment-grounding conductor can result in a fire or an electrical shock.
- An extension cord or electrical outlet must accept a three-prong plug. Extension cord should be a three-wire No. 12 AWG, and be as short as possible. The use of improper extension cord could result in fire or an electrical shock.
- Do not operate the charger if it has received a sharp blow, was dropped, or otherwise damaged in any way.
- Have worn, cut, or damaged power cords or wires replaced immediately.
- Do not use near fuels, grain dust, solvents, thinners, or other flammables. Chargers can ignite flammable materials and vapors.
- Do not expose to rain or any liquid. Keep the charger dry.
- Never push objects of any kind into the charger through cabinet slots. They may touch dangerous voltage points or cause an electrical short circuit that could result in fire or electrical shock.
- Do not connect a stationary charger to the receptacle if the charger cord, plug, or the vehicle receptacle is broken, damaged, or does not make a good electrical connection. Fire or personal injury can result. Have a qualified technician replace the parts.
- 36-Volt Accu-Power Charger: Do not disconnect the DC output plug from the vehicle receptacle when the charger is on. The resulting arcing and burning could damage the plug and receptacle and could cause batteries to explode. If the charger must be stopped, disconnect the AC supply plug from the wall outlet before disconnecting the charger DC cord from the vehicle receptacle.
- 48-Volt PowerDrive Charger: When the charger is on, the charger DC cord may be disconnected from the vehicle receptacle slowly. Jerking or pulling the DC cord out quickly could cause arcing and burning that could damage the plug and receptacle and could cause batteries to explode.

## **CAUTION**

- Do not block or cover the charger ventilation slots. The slots provide ventilation and protect the charger from overheating.
- Do not allow clothing, blankets, or other material to cover the charger.
- Do not allow the charger to operate for more than 30 minutes at 19 or more amperes.
- **36-Volt Accu-Power Charger:** Do not leave the DC cord plugged into a vehicle receptacle while unattended for more than two consecutive days. Severe overheating and damage to the batteries may result if the charger does not turn off.
- Install surge arrestors on incoming AC power lines. Surge arrestors will help protect electrical components in the charger and on the vehicle from all but direct or close lightning strikes.

**NOTE:** Because the PowerDrive Charger has a storage charge feature that automatically checks and recharges the batteries as necessary every 15 days, it can remain plugged to a PowerDrive or IQ System vehicle throughout the storage period.

*Shortly after charging begins, the PowerDrive Charger will shut off in order to run a self-diagnostic program (ammeter will drop to zero). Charging will resume in a few moments (ammeter returns to previous rate of charge). This will be repeated at one hour and at two hours into the charge cycle.*

Each electric vehicle is supplied with a fully automatic battery charger as standard equipment. The AC cord to each charger is to be connected to a source capable of supplying 10 amperes minimum per charger.

To reduce the risk of electric shock, the battery charger must be grounded. The charger is equipped with an AC electric cord having an equipment-grounding conductor and a grounding type plug. The AC plug must be connected to an appropriate receptacle that is properly installed and grounded in accordance with the National Electrical Code and all local codes and ordinances. See the owner's manual supplied with the charger for specific operating instructions before using the charger.

The use of an extension cord with the charger should be avoided. If an extension cord must be used, use a three-conductor no. 12 AWG (American Wire Gauge) or no. 14 SWG (British Standard Wire Gauge), heavy-duty cord with ground, properly wired and in good electrical condition. Keep it as short as possible (no more than 12 feet (3.7 m)). Place all cords so they will not be stepped on, tripped over, or otherwise subject to damage or stress.

Ensure that the charger ventilation slots are unobstructed and that there is adequate ventilation.

## **CHARGING BATTERIES**

### **WARNING**

- Be sure all wire connections at the receptacle and the fuse link are clean and tight.
- Do not rock or bend the plug. To connect the charger plug to the vehicle receptacle, grasp the plug handle and push the plug straight into the receptacle (Figure 14, Page 32).
- Do not pull on the DC cord (Figure 15, Page 32). Do not twist, rock or bend the plug. To disconnect the charger plug from the vehicle receptacle, grasp the plug by the handle and pull the plug straight out of the receptacle.



- **Do not connect a charger to the receptacle if the charger cord, plug, or the vehicle receptacle is broken, damaged in any manner, or does not make a good electrical connection. Fire or personal injury can result. Have it replaced by a qualified service person immediately.**
- **Failure to follow these instructions could result in damage to the charger cord, the plug, and (or) the vehicle receptacle.**
- **Do not use a charger if:**
  - **The plug is too loose or does not make a good connection.**
  - **The plug and receptacle feel hotter than normal during charge.**
  - **The plug pins (PowerDrive Chargers) or blades (Accu-Power Chargers), or receptacle contacts are bent or corroded.**
  - **The plug, receptacle, or cords are cut, worn, have any exposed wires or are damaged in any way.**
- **Using the charger with any of the above symptoms could result in a fire, property damage, personal injury, or death.**

***NOTE:** When temperatures fall below 65 °F (18.3 °C), batteries charged in unheated areas should be placed on charge as soon as possible after use. Batteries are warmest immediately after use, and cold batteries require more time to fully charge.*

Insert the charger DC plug into the vehicle receptacle. The charger will turn on two to ten seconds later (**Figure 14**).

When inserting the DC plug, align the raised guide on the plug with the guide slot in the receptacle and push straight in slowly.

The PowerDrive Charger interacts with an onboard computer on PowerDrive System 48 and IQ System vehicles. The computer records the amount of energy consumed during vehicle use. While the charger is plugged in, the vehicle's control circuit is locked out, preventing operation of the vehicle, as well as the possibility of consequent damage to the charger and the vehicle.

Once the lockout is actuated, the charger turns on. The onboard computer then records the amount of energy being returned to the batteries. When the optimum amount of energy needed to replenish the batteries is returned, the charger will shut off. The control circuit lockout remains activated until the charger plug is disconnected from the vehicle.

Only PowerDrive System 48 and IQ System vehicles are compatible with PowerDrive chargers. Other Club Car models or vehicles made by other manufacturers are not compatible.

As long as the charger is allowed to shut off by itself, the batteries will be fully charged. Overcharging and undercharging will normally be prevented.

Batteries should be put on charge even if they have been used for only a short period (9 holes of golf or 10 minutes). The charger is automatic and will turn off when batteries are fully charged. If the charger does not seem to be operating properly, or if the batteries seem weak, contact your local Club Car distributor/dealer.

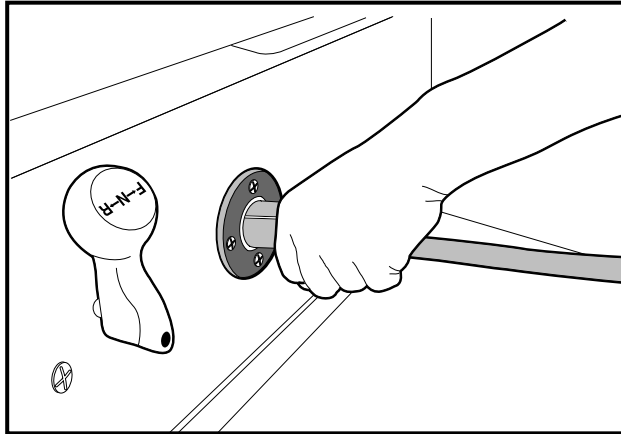

Figure 14 Correct Insertion of Charger DC Plug

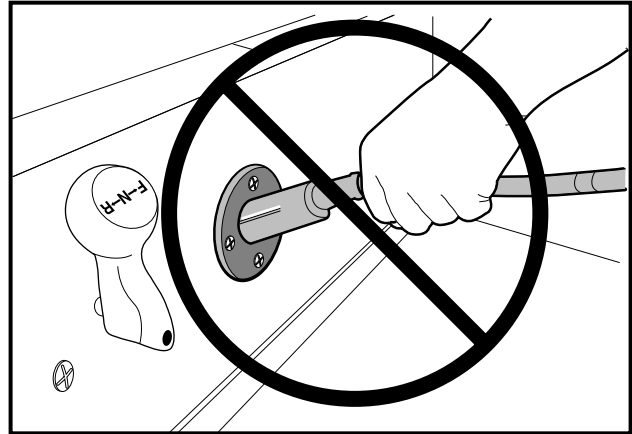

Figure 15 Incorrect Insertion of Charger DC Plug

## PLUG AND RECEPTACLE

The charger cord, plug, and receptacle are wear items and should be inspected daily. Visually inspect them for cracks, loose connections, and frayed wiring; they must be replaced when worn or damaged. If charger plug or receptacle show signs of corrosion or the plug is difficult to insert or remove, the receptacle contacts and plug terminals should be cleaned with a good electrical contact cleaner or lightly sprayed with WD-40® brand spray lubricant. The plug should then be inserted and removed several times to ensure ease of insertion, ease of removal, and good electrical contact. **See following NOTE.**

**NOTE:** If the warning tag has been damaged or removed from the DC cord, have it replaced immediately.

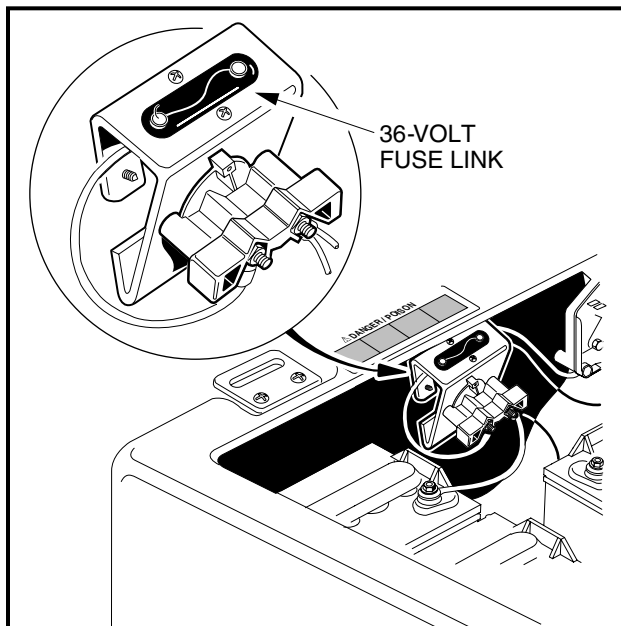

Figure 16 Receptacle Fuse Link for 36-Volt Vehicle

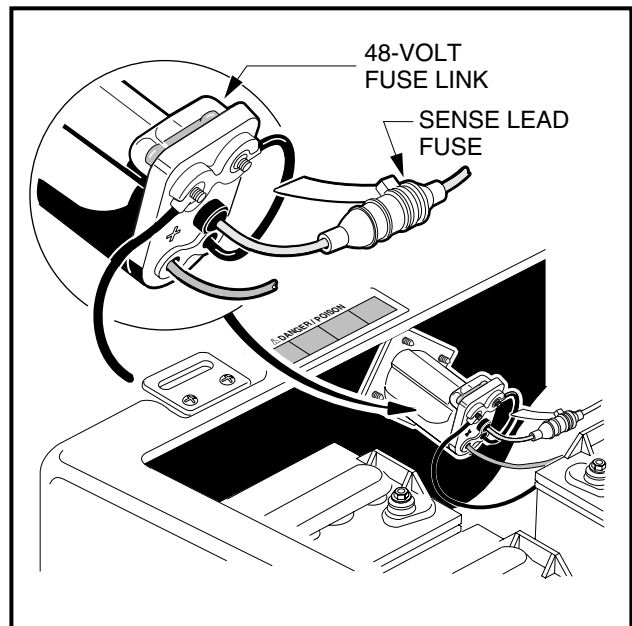

Figure 17 Receptacle Fuse Link for 48-Volt and IQ System Vehicles

## RECEPTACLE FUSE LINK

As an additional feature to protect the batteries and charging circuit from an overload, the electric vehicle is equipped with a receptacle fuse link (**Figure 16 for V-Glide 36-Volt vehicles, or Figure 17 for PowerDrive System 48 and IQ System vehicles**). If the charger does not come on when the vehicle is placed on charge, visually inspect the fuse link. **See following WARNING.**

### **⚠ WARNING**

- **If the receptacle fuse link is blown, determine the source of the electrical problem and correct it before replacing the fuse. Contact your nearest Club Car distributor/dealer.**

## CLEANING THE VEHICLE

Club Car DS vehicles are equipped with ArmorFlex<sup>®</sup> front and rear bodies. Use only commercially available automotive cleaners with a sponge or soft cloth for normal cleaning. A garden hose at normal residential water pressure is adequate.

Club Car does not recommend any type of pressure washing or steam cleaning. Such a process (especially if the vehicle has an ArmorFlex rear body that is removed) will expose electrical components to moisture. Moisture entering electrical components can result in water damage and subsequent component failure.

Use non-abrasive wax products. Battery acid, fertilizers, tars, asphalt, creosote, paint, or chewing gum should be removed immediately to prevent possible stains.

The seats of the vehicle will last longer with proper cleaning. Use a solution of 10% liquid soap and warm water applied with a soft cloth. For imbedded dirt, a soft bristle brush may be used. For heavy soiling, difficult stains or scratches, blemishes, or other body damage, see Section 4 of the appropriate maintenance and service manual.

**NOTE:** *Dispose of waste water properly.*

## ACCESSORIES

There is a complete line of accessory equipment available from Club Car and our dealers/distributors. Care should be taken that these accessories are properly installed by trained technicians, and that they are used in the manner for which they were designed. **See following WARNING.**

### **⚠ WARNING**

- **Tinted windshields and weather-proof enclosures will not protect occupants from flying objects (golf balls, etc.).**

### ACCESSORY EQUIPMENT

Accent striping	Glove box	Hour meter
Custom club decals	Performance grade tires	Information holder
Number decals	Standard tread tires	Beverage cooler
Rear rain curtain	Extra traction tires	Extra two-bag attachment
Weather-proof enclosure	DC to DC converter	Sand bunker rake kit
Tinted split hinged windshield	Chrome hub wheel covers	Battery indicator
Differential guard	Trailer hitch	Ashtray

Sand bottle divot repair kit	Uncommon key switch	Club protector
Sand bucket divot repair kit	Permanent tow bar for multiple vehicle towing (factory installed)	Lighting package (headlights, taillights, brake lights and horn)
Turn signals (for vehicles with lights)	3.5 hp electric motor (V-Glide 36-Volt vehicle only)*	Rear view mirror
Temporary tow bar for single vehicle towing	Onboard tow bar	Private speed mode (IQ System vehicle only)*

**\*NOTICE:** This accessory will increase the speed of the vehicle so that it will not conform to the speed criteria of the ANSI Z130.1 Standard for Golf Cars/Safety and Performance Requirements. The vehicle speed will exceed 15 miles per hour (24 km/h).

## SUBSEQUENT OWNER REGISTRATION

In the event a vehicle is bought as a used vehicle from another individual or from a distributor/dealer, we strongly urge the new owner to register the vehicle with Club Car. This will enable us to contact you if the need arises. Please send your name, address, and serial number(s) of the vehicle(s) to CLUB CAR, INC., P.O. Box 204658, Augusta, Georgia 30917-4658, Attention: Vehicle Registration.

## VEHICLE SPECIFICATIONS

SPECIFICATIONS	POWERDRIVE SYSTEM 48	IQ SYSTEM	36-VOLT
<b>POWER SOURCE</b>			
<b>Drive motor:</b> Direct drive, 48 volts DC, series-wound, 3.1 hp	•		
<b>Drive motor:</b> Direct drive, 48 volts DC, shunt-wound, 3.2 hp		•	
<b>Drive motor:</b> Direct drive, 36 volts DC, series-wound, 2.97 hp			•
<b>Transaxle:</b> Double reduction helical gear with 12.3:1 direct drive axle	•	•	•
<b>Transaxle:</b> Double reduction helical gear with 12.44:1 direct drive axle			•
<b>Electrical system:</b> 48 volts DC, reduced speed reverse	•	•	
<b>Electrical system:</b> 36 volts DC, reduced speed reverse			•
<b>Batteries:</b> High capacity, deep cycle, Trojan PowerDrive 8-volt, 117 min. capacity	•	•	
<b>Batteries:</b> High capacity, deep cycle, Trojan 6-volt, 115 min. capacity			•
<b>Charger:</b> Automatic, 48-volt; UL and CSA listed	•	•	
<b>Charger:</b> Automatic, 36-volt; UL and CSA listed			•
<b>STEERING/SUSPENSION/BRAKES</b>			
<b>Steering:</b> Self-adjusting rack and pinion	•	•	•
<b>Suspension:</b> Front and rear tapered mono-leaf springs with dual hydraulic shocks	•	•	•
<b>Brakes:</b> Dual rear wheel self-adjusting brakes with cast iron drums and single brake pedal with automatic-release park brake	•	•	•
<b>BODY/CHASSIS</b>			
<b>Frame/Chassis:</b> Twin I-Beam welded aluminum	•	•	•
<b>Front and rear body:</b> ArmorFlex®	•	•	•
<b>Body finish:</b> Matched paint finish over molded-in color	•	•	•
<b>Tires:</b> 18 x 8.5 – 8 tubeless, 4 ply rated	•	•	•
Vehicle Specifications continued on next page...			

<b>SPECIFICATIONS</b>	<b>POWERDRIVE SYSTEM 48</b>	<b>IQ SYSTEM</b>	<b>36-VOLT</b>
<b>DIMENSIONS/WEIGHT</b>			
Overall length	91.5 in. (232 cm)		
Overall width	47.25 in. (120 cm)		
Overall height (with canopy)	68.5 in. (174 cm)		
Overall height (at steering wheel)	48 in. (122 cm)		
Wheelbase	65.5 in. (166 cm)		
Ground clearance	4.5 in. (11 cm)		
Front wheel tread	34.5 in (88 cm)		
Rear wheel tread	38.5 in. (98 cm)		
Weight (standard electric vehicle with canopy, without batteries)	476 lb. (216 kg)		469 lb. (213 kg)
Weight (IQ System vehicle with canopy, without batteries)		494 lb. (224 kg)	
Forward speed	12-15 mph (19-24 km/h)		
Curb clearance circle (diameter)	17 ft.-6 in. (533 cm)		
Braking distance (at 12 mph (19 km/h))	14 ft. (427 cm)		
Standard seating capacity	2	2	2
<b>LIQUID CAPACITIES</b>			
Transaxle	22 oz. (.67 liters)	22 oz. (.67 liters)	
Transaxle (Type K or G)			22 oz. (0.67 liters)
Transaxle (Type D)			11 oz. (0.33 liters)
<b>TIRE PRESSURE</b>			
Front and rear	18-20 psi (1.24-1.38 Bars)		

# CLUB CAR<sup>®</sup> LIMITED LIFETIME WARRANTY FOR 2003 FLEET GOLF CARS

---

## 1. Warranty:

CLUB CAR, INC., ("CLUB CAR") hereby warrants to the Original Retail Fleet Purchaser or Original Retail Fleet Lessee, as those terms are defined herein, and subject to the provisions, limitations and exclusions contained in this limited warranty, that its new 2003 Model DS golf car purchased from CLUB CAR or an authorized distributor or dealer shall be free from defects in material and workmanship under normal use and service as a golf car for the periods stated below, subject to the provisions, limitations, and exclusions contained in this limited warranty.

**LIMITED LIFETIME WARRANTY:** The golf car frame (excluding the front and rear bumper mounts), rack and pinion steering gearbox unit and suspension system (defined as the shock absorbers, shock mounts, A-plates, leaf springs, shackles and associated hardware) are warranted for the lifetime of the vehicle with respect to parts and labor against defects in material and workmanship from the date of purchase while owned by the Original Retail Fleet Purchaser or in the possession of the Original Retail Fleet Lessee.

**LIMITED THREE YEAR WARRANTY:** The gasoline engine, torque converter (drive and driven), unitized transaxle, starter generator, transaxle (electric vehicle) and electric motor are warranted for a period of three years with respect to parts and labor against defects in material and workmanship from the date of purchase while owned by the Original Retail Fleet Purchaser or in the possession of the Original Retail Fleet Lessee.

**LIMITED TWO YEAR WARRANTY:** All remaining components of the golf car not specified otherwise, except options and accessories, are warranted for a period of two years with respect to parts and labor against defects in material and workmanship from the date of purchase while owned by the Original Retail Fleet Purchaser or in the possession of the Original Retail Fleet Lessee.

**LIMITED ONE YEAR WARRANTY:** All original equipment options and accessories supplied by CLUB CAR are warranted with respect to parts and labor against defects in material and workmanship for a period of one year from the date of purchase while owned by the Original Retail Fleet Purchaser or in the possession of the Original Retail Fleet Lessee.

This limited warranty covers material, workmanship and repair labor cost as to those items specifically listed above for the periods specified. Such repair labor shall be performed only by CLUB CAR, its authorized distributors or dealers, or a service agency approved by CLUB CAR.

IF THE WARRANTY REGISTRATION FORM IS NOT COMPLETED AND RETURNED TO CLUB CAR AT THE TIME OF THE ORIGINAL RETAIL SALE, PURCHASER MUST PROVIDE PROOF OF DATE OF PURCHASE WITH ANY WARRANTY CLAIM.

## 2. EXCLUSIONS:

Excluded from any CLUB CAR warranty are all fuses, filters, decals (except safety decals), spark plugs, light bulbs, lubricants, trim pieces, seats, routine wear items such as the charger plug and receptacle, brake shoes, belts, brushes, bushings, engine mounts, mats and pads, maintenance adjustments, cosmetic deterioration, and items which deteriorate or fail due to exposure or ordinary wear and tear. Batteries, battery charger, onboard computer, and solid-state speed controller are covered under separate CLUB CAR warranties. Also excluded from any CLUB CAR warranty is damage to a golf car or component resulting from a cause other than a defect including unreasonable or unintended strain or use, improper installation of accessories, installation of parts or accessories that are not original equipment, overloading, accident, alteration, abuse or neglect.

Transportation expenses for warranty services are also excluded from this warranty.

## 3. VOIDING OF WARRANTY:

THIS AND ANY OTHER WARRANTY SHALL BE VOID IF THE GOLF CAR IS ABUSED OR USED IN AN UNINTENDED MANNER OR SHOWS INDICATIONS THAT IT HAS BEEN ALTERED IN ANY WAY, INCLUDING, BUT NOT LIMITED TO, MODIFICATION OF THE SPEED GOVERNOR, BRAKING SYSTEM, STEERING, TRANSAXLE, OR OTHER OPERATING SYSTEMS OF THE CAR TO CAUSE IT TO PERFORM OUTSIDE CLUB CAR SPECIFICATIONS. THE WARRANTY IS LIKEWISE VOID IF THE CAR INVOLVED SHOWS INDICATIONS THAT REASONABLE OR NECESSARY MAINTENANCE AS OUTLINED IN THE OWNER'S MANUAL AND MAINTENANCE AND SERVICE MANUAL WAS NOT PERFORMED AT THE TIME AND IN THE MANNER SPECIFIED IN SUCH MANUALS.

## 4. SOLE REMEDY:

CLUB CAR's liability under this limited warranty, or in any action whether based upon warranty, contract, negligence, strict product liability or otherwise, shall be the repair or replacement, at CLUB CAR's option, of the golf car or component thereof that CLUB CAR deems to be defective. Replacement shall mean furnishing, during the applicable limited warranty period, a

new golf car or factory-reconditioned vehicle or component thereof that is identical or reasonably equivalent to the warranted product or component at no cost to the purchaser. Repair shall mean remedying a defect in the golf car or component thereof at no cost to the purchaser during the applicable limited warranty period. If CLUB CAR elects to repair the golf car, it may provide factory-reconditioned parts or components. All parts and components replaced under warranty shall become the property of CLUB CAR.

#### **5. HOW TO MAKE A WARRANTY CLAIM:**

To make a warranty claim under this limited warranty, you must present the golf car or defective component to an authorized CLUB CAR distributor or dealer or send the defective component, freight prepaid, to WARRANTY SERVICES, CLUB CAR, INC., 4125 Washington Road, Evans, Georgia 30809, U.S.A., 706-863-3000.

#### **6. DEFINITIONS:**

For the purpose of this warranty, an Original Retail Fleet Purchaser is the original purchaser of the golf car who is in the business of owning or operating golf courses and who purchases such golf car for the purpose of renting it to golf players for use on such courses. An Original Retail Fleet Lessee is the first end-user of the golf car who is in the business of owning and operating golf courses and who leases such golf car for the purpose of renting it to golf players for use on such golf courses. In the event the golf car is purchased or leased by any entity for the purpose of leasing it to an Original Retail Fleet Lessee, then this limited warranty shall extend only to the first Original Retail Fleet Lessee, and not to such entity or to any subsequent lessee of the golf car.

#### **7. DISCLAIMER:**

**THIS LIMITED WARRANTY IS EXCLUSIVE. CLUB CAR MAKES NO OTHER WARRANTY OF ANY KIND, EXPRESSED OR IMPLIED. ANY IMPLIED WARRANTIES OF MERCHANTABILITY OR FITNESS FOR A PARTICULAR PURPOSE WHICH EXCEED THE OBLIGATIONS OR TIME LIMITS STATED IN THIS WARRANTY ARE HEREBY DISCLAIMED BY CLUB CAR AND EXCLUDED FROM THIS WARRANTY. THE PURCHASER AND CLUB CAR EXPRESSLY AGREE THAT THE SOLE REMEDY OF THE REPLACEMENT OR REPAIR OF THE DEFECTIVE GOLF CAR OR COMPONENT THEREOF IS THE SOLE REMEDY OF THE PURCHASER. CLUB CAR MAKES NO OTHER REPRESENTATION OR WARRANTY OF ANY KIND, AND NO REPRESENTATIVE, EMPLOYEE, DISTRIBUTOR OR DEALER OF CLUB CAR HAS THE AUTHORITY TO MAKE OR IMPLY ANY REPRESENTATION, PROMISE OR AGREEMENT, WHICH IN ANY WAY VARIES THE TERMS OF THIS WARRANTY.**

#### **8. NO CONSEQUENTIAL DAMAGES:**

**IN NO EVENT SHALL CLUB CAR BE LIABLE FOR ANY INCIDENTAL OR CONSEQUENTIAL DAMAGES INCLUDING, BUT NOT LIMITED TO, LOSS RELATED TO PROPERTY OTHER THAN THE GOLF CAR, LOSS OF USE, LOSS OF TIME, INCONVENIENCE, OR ANY OTHER ECONOMIC LOSS.**

Some states allow neither limitation on the duration of an implied warranty nor exclusions or limitation of incidental or consequential damages. Therefore, the above limitations or exclusions may not apply to you.

This warranty gives you specific legal rights, and you may also have other rights, which vary from state to state.

#### **9. INFORMATION:**

For further information contact WARRANTY SERVICES, CLUB CAR, INC., P.O. Box 204658, Augusta, Georgia 30917-4658, U.S.A., 706-863-3000.

#### **10. WARNING:**

Any modification or alteration of any golf car beyond factory specifications, including those that affect the weight distribution, stability, or speed of the golf car, can cause serious personal injury or death.

## **CLUB CAR<sup>®</sup> LIMITED THREE YEAR WARRANTY FOR 2003 T-105 6-VOLT BATTERIES**

---

CLUB CAR, INC., ("CLUB CAR") hereby warrants to the original retail purchaser that the new "Trojan T-105" 6-Volt Battery installed in its new electric vehicle purchased from CLUB CAR or an authorized distributor or dealer will be free from defects in material and workmanship and will provide 36 hole performance (60 minute discharge capacity) for a period of three years or 600 rounds from the date of purchase, whichever first occurs, subject to the terms and conditions contained herein.

This limited warranty only covers defects in material and workmanship for a period of three years or 600 golf car rounds from date of purchase. The terms of this three-year or 600 round limited warranty shall be as follows:

Free replacement with respect to parts and labor within three years or 600 rounds, whichever first occurs, from date of purchase.

The battery should be returned to an authorized CLUB CAR distributor or dealer with evidence of proof of purchase date and number of rounds, freight prepaid. CLUB CAR reserves the right to test and recharge any battery returned for adjustment.

### **LIMITED WARRANTY EXCLUSIONS**

THE PROVISIONS OF THIS LIMITED WARRANTY SHALL NOT APPLY TO FAILURE DUE TO:

- 1) Abuse such as overcharging, undercharging, improper fluid levels, loose wiring, or rusted or corroded hardware;
- 2) Lack of proper maintenance as outlined in the electric vehicle owner's manual;
- 3) Damages caused by improper installation of the battery;
- 4) Neglect, breakage, freezing, fire, explosion, wreckage, the addition of any chemical, or the operation of the battery in an uncharged condition (below half charge – 1,200 specific gravity);
- 5) A battery damaged by a defective charger.

Without limiting the generality of the foregoing in any way, and as part of its limited warranty exclusion, CLUB CAR does not warrant that its battery is suitable for use in any application other than in its products. As in the use of any battery, a prudent owner will read and study the charger owner's manual, the electric vehicle owner's manual, the operator instructions, and the battery warning labels; and will exercise due care in working on or around batteries.

Transportation expenses for warranty services are also excluded from this warranty.

### **WARRANTY LIMITATIONS**

CLUB CAR's liability under this limited warranty shall be to replace a defective battery. Replacement shall be furnishing a new or used battery with sufficient life to complete the remainder of the warranty term, which is identical or reasonably equivalent to the warranted product at no cost to the purchaser during the three-year or 600 round limited warranty period, whichever first occurs. All batteries, which are replaced under this limited warranty, become the property of CLUB CAR.

**THIS LIMITED WARRANTY IS EXCLUSIVE. CLUB CAR MAKES NO OTHER WARRANTY OF ANY KIND, EXPRESSED OR IMPLIED. ANY IMPLIED WARRANTIES OF MERCHANTABILITY OR FITNESS FOR A PARTICULAR PURPOSE WHICH EXCEED THE OBLIGATIONS OR TIME LIMITS STATED IN THIS WARRANTY ARE HEREBY DISCLAIMED BY CLUB CAR AND EXCLUDED FROM THIS WARRANTY. THE PURCHASER AND CLUB CAR EXPRESSLY AGREE THAT THE REPLACEMENT OR REPAIR OF THE DEFECTIVE VEHICLE OR COMPONENT THEREOF IS THE SOLE REMEDY OF THE PURCHASER. CLUB CAR MAKES NO OTHER REPRESENTATION OR WARRANTY OF ANY KIND AND NO REPRESENTATIVE, EMPLOYEE, DISTRIBUTOR OR DEALER OF CLUB CAR HAS THE AUTHORITY TO MAKE OR IMPLY ANY REPRESENTATION, PROMISE OR AGREEMENT, WHICH IN ANY WAY VARIES THE TERMS OF THIS WARRANTY.**

This battery is intended to be used by persons with training and experience with batteries and only in CLUB CAR electric vehicles. Any other use renders the Limited Warranties expressed herein and all implied warranties null and void and same are hereby excluded.

**ALSO EXCLUDED FROM THIS LIMITED WARRANTY ARE ANY AND ALL INCIDENTAL OR CONSEQUENTIAL DAMAGES INCLUDING, BUT NOT LIMITED TO, LOSS OF USE OR REVENUE, LOSS OF TIME, INCONVENIENCE OR ANY OTHER ECONOMIC LOSS.**

Damage not resulting from a defect in material or workmanship or that occurs due to abuse or neglect (including failure to provide reasonable and necessary maintenance), accident or alteration is excluded from this limited warranty.

Some states allow neither limitation on the duration of an implied warranty nor exclusions or limitations of incidental or consequential damages. Therefore, the above limitations or exclusions may not apply to you.

This warranty gives you specific legal rights, and you may also have other rights, which vary from states to states.

For further information contact WARRANTY SERVICES, CLUB CAR, INC., P.O. Box 204658, Augusta, Georgia, 30917-4658, U.S.A., 706-863-3000.



# **CLUB CAR<sup>®</sup> LIMITED FOUR YEAR WARRANTY FOR 2003 POWERDRIVE<sup>®</sup> 8-VOLT BATTERIES**

---

CLUB CAR, INC., ("CLUB CAR") hereby warrants to the original retail purchaser that the new PowerDrive 8-volt Battery installed in its new electric vehicle equipped with the PowerDrive System 48™, PowerDrive Plus<sup>®</sup> or IQ System™, purchased from CLUB CAR or an authorized distributor or dealer will be free from defects in material and workmanship and will provide 36-hole performance (60 minute discharge capacity) for a period of four years or 800 rounds, whichever first occurs, from the date of purchase subject to the terms and conditions contained herein.

This limited warranty only covers defects in material and workmanship for a period of four years or 800 golf car rounds from date of purchase. The terms of this four-year or 800 round limited warranty shall be as follows:

Vehicles used for golf, free replacement with respect to parts and labor within four years or 800 rounds, whichever first occurs, from date of purchase.

Vehicles used for purposes other than golf, free replacement with respect to parts and labor within four years or 16,000 energy units as recorded by the Onboard Computer, whichever first occurs, from the date of purchase.

The battery should be returned to an authorized CLUB CAR distributor or dealer with evidence of proof of purchase date and number of rounds, freight prepaid. CLUB CAR reserves the right to test and recharge any battery returned for adjustment, and to verify number of rounds played by accessing information contained in the PowerDrive System 48, PowerDrive Plus, or IQ System Onboard Computer.

## **LIMITED WARRANTY EXCLUSIONS**

THE PROVISIONS OF THIS LIMITED WARRANTY SHALL NOT APPLY TO FAILURE DUE TO:

- 1) Abuse such as overcharging, undercharging, improper fluid levels, loose wiring, or rusted or corroded hardware;
- 2) Lack of proper maintenance as outlined in the electric vehicle owner's manual;
- 3) Damages caused by improper installation of the battery;
- 4) Neglect, breakage, freezing, fire, explosion, wreckage, the addition of any chemical, or the operation of the battery in an uncharged condition (below half charge – 1,200 specific gravity);
- 5) A battery damaged by a defective charger.

Without limiting the generality of the foregoing in any way, and as part of its limited warranty exclusion, CLUB CAR does not warrant that its PowerDrive battery is suitable for use in any application other than in its products. As in the use of any battery, a prudent owner will read and study the charger owner's manual, the electric vehicle owner's manual, the operator instructions, and the battery warning labels; and will exercise due care in working on or around batteries.

Transportation expenses for warranty services are also excluded from this warranty.

## **WARRANTY LIMITATIONS**

CLUB CAR's liability under this limited warranty shall be to replace a defective battery. Replacement shall be furnishing a new or used battery with sufficient life to complete the remainder of the warranty term, which is identical or reasonably equivalent to the warranted product at no cost to the purchaser during the four-year, 800 round or 16,000 Energy Unit limited warranty period, whichever first occurs. All batteries, which are replaced under this limited warranty, become the property of CLUB CAR.

**THIS LIMITED WARRANTY IS EXCLUSIVE. CLUB CAR MAKES NO OTHER WARRANTY OF ANY KIND, EXPRESSED OR IMPLIED. ANY IMPLIED WARRANTIES OF MERCHANTABILITY OR FITNESS FOR A PARTICULAR PURPOSE WHICH EXCEED THE OBLIGATIONS OR TIME LIMITS STATED IN THIS WARRANTY ARE HEREBY DISCLAIMED BY CLUB CAR AND EXCLUDED FROM THIS WARRANTY. THE PURCHASER AND CLUB CAR EXPRESSLY AGREE THAT THE REPLACEMENT OR REPAIR OF THE DEFECTIVE VEHICLE OR COMPONENT THEREOF IS THE SOLE REMEDY OF THE PURCHASER. CLUB CAR MAKES NO OTHER REPRESENTATION OR WARRANTY OF ANY KIND AND NO REPRESENTATIVE, EMPLOYEE, DISTRIBUTOR OR DEALER OF CLUB CAR HAS THE AUTHORITY TO MAKE OR IMPLY ANY REPRESENTATION, PROMISE OR AGREEMENT, WHICH IN ANY WAY VARIES THE TERMS OF THIS WARRANTY.**

This battery is intended to be used by persons with training and experience with batteries and only in CLUB CAR electric vehicles. Any other use renders the Limited Warranties expressed herein and all implied warranties null and void and same are hereby excluded.

**ALSO EXCLUDED FROM THIS LIMITED WARRANTY ARE ANY AND ALL INCIDENTAL OR CONSEQUENTIAL DAMAGES INCLUDING, BUT NOT LIMITED TO, LOSS OF USE OR REVENUE, LOSS OF TIME, INCONVENIENCE OR ANY OTHER ECONOMIC LOSS.**

Damage not resulting from a defect in material or workmanship or that occurs due to abuse or neglect (including failure to provide reasonable and necessary maintenance), accident or alteration is excluded from this limited warranty.

Some states allow neither limitation on the duration of an implied warranty nor exclusions or limitations of incidental or consequential damages. Therefore, the above limitations or exclusions may not apply to you.

This warranty gives you specific legal rights, and you may also have other rights, which vary from state to state.

For further information contact WARRANTY SERVICES, CLUB CAR, INC., P.O. Box 204658, Augusta, Georgia, 30917-4658, U.S.A., 706-863-3000.

## **CLUB CAR<sup>®</sup> LIMITED THREE YEAR WARRANTY FOR 2003 36-VOLT BATTERY CHARGERS**

---

CLUB CAR, INC., ("CLUB CAR") hereby warrants to the original retail purchaser that its new Ultra-Power II or Accu-Power Charger purchased from CLUB CAR or an authorized distributor or dealer will be free from defects in material and workmanship under normal use and service for a period of three years from the date of purchase, subject to the terms, provisions, limitations, and exclusions contained herein.

The limited warranty with respect to parts and labor only covers defects in material and workmanship for a period of three years from the date of purchase. Such repair labor shall be performed only by CLUB CAR or by an authorized distributor or dealer. Purchaser shall be responsible for all freight costs to and from CLUB CAR's facility.

### **LIMITED WARRANTY EXCLUSIONS**

THE PROVISIONS OF THIS LIMITED WARRANTY SHALL NOT APPLY TO FAILURE DUE TO:

- 1) Lack of normal maintenance services such as preventive maintenance checks and tightening loose wire connections;
- 2) Semiconductor parts such as diodes and fuses which are vulnerable to electrical overloads (including lightning) beyond the control of CLUB CAR;
- 3) Charger DC cord set with plug, which is a wear item and subject to user abuse.

Any warranty service, which includes labor during the first year, must be performed by CLUB CAR or by an authorized distributor or dealer. For repairs made by qualified technicians other than CLUB CAR's factory technicians or an authorized distributor or dealer, CLUB CAR will provide only the replacement parts or components.

This charger is intended to be used by persons with knowledge of the charger and proper charging practices and only on CLUB CAR 36-Volt vehicles. Any other use renders the Limited Warranties expressed herein and any implied warranties null and void and same are hereby excluded.

Without limiting the generality of the foregoing in any way, and as part of its limited warranty exclusion, CLUB CAR does not warrant that the Ultra-Power II or Accu-Power Charger is suitable for use in any application other than its 36-volt products. As in the use of any electrical device, a prudent owner will read and study the charger owner's manual, the electric vehicle owner's manual, the operator instructions, and the battery warning labels; and will exercise due care in working on or around electrical devices.

Transportation expenses for warranty services are also excluded from this warranty.

### **WARRANTY LIMITATIONS**

CLUB CAR's liability under this limited warranty, or in any action whether based upon warranty, contract, negligence, strict product liability or otherwise, shall be the replacement or repair of a charger or component thereof that CLUB CAR deems to be defective. Replacement shall mean furnishing, during the applicable limited warranty period, a new charger or component thereof that is identical or reasonably equivalent to the warranted product or defective component at no cost to the purchaser. Repair shall mean remedying a defect in the charger or component thereof at no cost to the purchaser during the applicable limited warranty period. If CLUB CAR elects to repair the charger, it may provide factory-reconditioned parts or components. All parts and components replaced under warranty shall become the property of CLUB CAR.

**THIS LIMITED WARRANTY IS EXCLUSIVE. CLUB CAR MAKES NO OTHER WARRANTY OF ANY KIND, EXPRESSED OR IMPLIED. ANY IMPLIED WARRANTIES OF MERCHANTABILITY OR FITNESS FOR A PARTICULAR PURPOSE WHICH EXCEED THE OBLIGATIONS OR TIME LIMITS STATED IN THIS WARRANTY ARE HEREBY DISCLAIMED BY**

**CLUB CAR AND EXCLUDED FROM THIS WARRANTY. THE PURCHASER AND CLUB CAR EXPRESSLY AGREE THAT THE REPLACEMENT OR REPAIR OF THE DEFECTIVE VEHICLE OR COMPONENT THEREOF IS THE SOLE REMEDY OF THE PURCHASER. CLUB CAR MAKES NO OTHER REPRESENTATION OR WARRANTY OF ANY KIND AND NO REPRESENTATIVE, EMPLOYEE, DISTRIBUTOR OR DEALER OF CLUB CAR HAS THE AUTHORITY TO MAKE OR IMPLY ANY REPRESENTATION, PROMISE OR AGREEMENT, WHICH IN ANY WAY VARIES THE TERMS OF THIS WARRANTY.**

**IN NO EVENT SHALL CLUB CAR BE LIABLE FOR ANY INCIDENTAL OR CONSEQUENTIAL DAMAGES INCLUDING, BUT NOT LIMITED TO, LOSS RELATED TO PROPERTY OTHER THAN THE BATTERY CHARGER, LOSS OF USE, LOSS OF TIME, INCONVENIENCE OR ANY OTHER ECONOMIC LOSS.**

Damage not resulting from a defect that occurs due to unreasonable use, abuse or neglect (including failure to provide reasonable or necessary maintenance), accident or alteration is excluded from the limited warranty.

Some states allow neither limitation on the duration of an implied warranty nor exclusions or limitations of incidental or consequential damages. Therefore, the above limitations or exclusions may not apply to you.

This warranty gives you specific legal rights, and you may also have other rights, which vary from state to state.

For further information contact WARRANTY SERVICES, CLUB CAR, INC., P.O. Box 204658, Augusta, Georgia 30917-4658, U.S.A., 706-863-3000.

## **CLUB CAR<sup>®</sup> LIMITED FOUR YEAR WARRANTY FOR 2003 POWERDRIVE<sup>®</sup> CHARGERS**

---

CLUB CAR, INC., ("CLUB CAR") hereby warrants to the original retail purchaser that its new PowerDrive Chargers purchased from CLUB CAR or an authorized distributor or dealer will be free from defects in material and workmanship under normal use and service for a period of four years from the date of purchase, subject to the terms, provisions, limitations, and exclusions contained herein.

The limited warranty with respect to parts and labor only covers defects in material and workmanship for a period of four years from the date of purchase. Such repair labor shall be performed only by CLUB CAR or by an authorized distributor or dealer. Purchaser shall be responsible for all freight costs to and from CLUB CAR's facility.

### **LIMITED WARRANTY EXCLUSIONS**

THE PROVISIONS OF THIS LIMITED WARRANTY SHALL NOT APPLY TO FAILURE DUE TO:

- 1) Lack of normal maintenance services such as preventive maintenance checks and tightening loose wire connections;
- 2) Semiconductor parts such as diodes and fuses which are vulnerable to electrical overloads (including lightning) beyond the control of CLUB CAR;
- 3) Charger DC cord set with plug, which is a wear item and subject to user abuse.

Any warranty service, which includes labor during the first year, must be performed by CLUB CAR or by an authorized distributor or dealer. For repairs made by qualified technicians other than CLUB CAR's factory technicians or an authorized distributor or dealer, CLUB CAR will provide only the replacement parts or components.

PowerDrive Chargers are intended to be used by persons with knowledge of the chargers and proper charging practices and only on CLUB CAR PowerDrive System 48™, PowerDrive Plus®, and IQ System™ vehicles. Any other use renders the Limited Warranties expressed herein and any implied warranties null and void and same are hereby excluded.

Without limiting the generality of the foregoing in any way, and as part of its limited warranty exclusion, CLUB CAR does not warrant that the PowerDrive Charger is suitable for use in any application other than its PowerDrive System 48, PowerDrive Plus, and IQ System products. As in the use of any electrical device, a prudent owner will read and study the charger owner's manual, the electric vehicle owner's manual, the operator instructions, and the battery warning labels; and will exercise due care in working on or around electrical devices.

Transportation expenses for warranty services are also excluded from this warranty.

### **WARRANTY LIMITATIONS**

CLUB CAR's liability under this limited warranty, or in any action whether based upon warranty, contract, negligence, strict product liability or otherwise, shall be the replacement or repair of a charger or component thereof that CLUB CAR deems

to be defective. Replacement shall mean furnishing, during the applicable limited warranty period, a new charger or component thereof that is identical or reasonably equivalent to the warranted product or defective component at no cost to the purchaser. Repair shall mean remedying a defect in the charger or component thereof at no cost to the purchaser during the applicable limited warranty period. If CLUB CAR elects to repair the charger, it may provide factory-reconditioned parts or components. All parts and components replaced under warranty shall become the property of CLUB CAR.

**THIS LIMITED WARRANTY IS EXCLUSIVE. CLUB CAR MAKES NO OTHER WARRANTY OF ANY KIND, EXPRESSED OR IMPLIED. ANY IMPLIED WARRANTIES OF MERCHANTABILITY OR FITNESS FOR A PARTICULAR PURPOSE WHICH EXCEED THE OBLIGATIONS OR TIME LIMITS STATED IN THIS WARRANTY ARE HEREBY DISCLAIMED BY CLUB CAR AND EXCLUDED FROM THIS WARRANTY. THE PURCHASER AND CLUB CAR EXPRESSLY AGREE THAT THE REPLACEMENT OR REPAIR OF THE DEFECTIVE VEHICLE OR COMPONENT THEREOF IS THE SOLE REMEDY OF THE PURCHASER. CLUB CAR MAKES NO OTHER REPRESENTATION OR WARRANTY OF ANY KIND AND NO REPRESENTATIVE, EMPLOYEE, DISTRIBUTOR OR DEALER OF CLUB CAR HAS THE AUTHORITY TO MAKE OR IMPLY ANY REPRESENTATION, PROMISE OR AGREEMENT, WHICH IN ANY WAY VARIES THE TERMS OF THIS WARRANTY.**

**IN NO EVENT SHALL CLUB CAR BE LIABLE FOR ANY INCIDENTAL OR CONSEQUENTIAL DAMAGES INCLUDING, BUT NOT LIMITED TO, LOSS RELATED TO PROPERTY OTHER THAN THE BATTERY CHARGER, LOSS OF USE, LOSS OF TIME, INCONVENIENCE, OR ANY OTHER ECONOMIC LOSS.**

Damage not resulting from a defect that occurs due to unreasonable use, abuse or neglect (including failure to provide reasonable or necessary maintenance), accident or alteration is excluded from the limited warranty.

Some states allow neither limitation on the duration of an implied warranty nor exclusions or limitations of incidental or consequential damages. Therefore, the above limitations or exclusions may not apply to you.

This warranty gives you specific legal rights, and you may also have other rights, which vary from state to state.

For further information contact WARRANTY SERVICES, CLUB CAR, INC., P.O. Box 204658, Augusta, Georgia 30917-4658, U.S.A., 706-863-3000.

## **CLUB CAR® LIMITED FOUR YEAR WARRANTY FOR 2003 ONBOARD COMPUTERS AND SOLID STATE SPEED CONTROLLERS**

---

CLUB CAR, INC., ("CLUB CAR") hereby warrants to the original retail purchaser that the new Onboard Computer and the Solid State Speed Controller, hereinafter called "Computer" and "Controller" respectively, installed in its new electric vehicle equipped with the PowerDrive® System 48™, PowerDrive Plus®, or IQ System™ purchased from CLUB CAR or an authorized distributor or dealer will be free from defects in material and workmanship for a period of four years or 800 rounds, whichever first occurs, from the date of purchase subject to the terms and conditions contained herein.

This limited warranty only covers defects in material and workmanship for a period of four years or 800 golf car rounds from date of purchase. The terms of this four-year or 800 round limited warranty shall be as follows:

Vehicles used for golf, free replacement with respect to parts and labor within four years or 800 rounds, whichever first occurs, from date of purchase.

Vehicles used for purposes other than golf, free replacement with respect to parts and labor within four years or 16,000 energy units as recorded by the Computer, whichever first occurs, from date of purchase.

The Computer or Controller should be returned to an authorized CLUB CAR distributor or dealer with evidence of proof of purchase date and number of rounds, freight prepaid. CLUB CAR reserves the right to test any Computer returned for warranty and to verify number of rounds played by accessing information contained in the Computer.

### **LIMITED WARRANTY EXCLUSIONS**

THE PROVISIONS OF THIS LIMITED WARRANTY SHALL NOT APPLY TO FAILURE DUE TO:

- 1) Abuse or neglect, such as improper battery fluid levels, loose wiring, or rusted or corroded hardware;
- 2) Lack of proper maintenance as outlined in the electric vehicle owner's manual;
- 3) Damages caused by improper installation of the Computer or Controller;
- 4) Vehicles charged by systems other than the CLUB CAR PowerDrive Charger.

Without limiting the generality of the foregoing in any way, and as part of its limited warranty exclusion, CLUB CAR does not warrant that the Computer or Controller is suitable for use in any application other than its PowerDrive System 48, PowerDrive Plus, and IQ System products. As in the use of any battery operated device, a prudent owner will read and

study the charger owner's manual, the electric vehicle owner's manual, the operator instructions, and the battery warning labels; and will exercise due care in working on or around batteries.

Transportation expenses for warranty services are also excluded from this warranty.

**WARRANTY LIMITATIONS:**

CLUB CAR's liability under this limited warranty shall be to replace a defective Computer or Controller. Replacement shall be furnishing a new or reconditioned Computer or Controller, which is identical or reasonably equivalent to the warranted product at no cost to the purchaser during the four-year or 800 round limited warranty period for golf use or 4 years or 16,000 energy units for use other than golf, whichever first occurs, except for transportation expenses. All parts and components replaced under this limited warranty become the property of CLUB CAR.

**THIS LIMITED WARRANTY IS EXCLUSIVE. CLUB CAR MAKES NO OTHER WARRANTY OF ANY KIND, EXPRESSED OR IMPLIED. ANY IMPLIED WARRANTIES OF MERCHANTABILITY OR FITNESS FOR A PARTICULAR PURPOSE WHICH EXCEED THE OBLIGATIONS OR TIME LIMITS STATED IN THIS WARRANTY ARE HEREBY DISCLAIMED BY CLUB CAR AND EXCLUDED FROM THIS WARRANTY. THE PURCHASER AND CLUB CAR EXPRESSLY AGREE THAT THE REPLACEMENT OR REPAIR OF THE DEFECTIVE VEHICLE OR COMPONENT THEREOF IS THE SOLE REMEDY OF THE PURCHASER. CLUB CAR MAKES NO OTHER REPRESENTATION OR WARRANTY OF ANY KIND AND NO REPRESENTATIVE, EMPLOYEE, DISTRIBUTOR OR DEALER OF CLUB CAR HAS THE AUTHORITY TO MAKE OR IMPLY ANY REPRESENTATION, PROMISE OR AGREEMENT WHICH IN ANY WAY VARIES THE TERMS OF THIS WARRANTY.**

This computer or controller is intended to be used only in CLUB CAR PowerDrive System 48, PowerDrive Plus, and IQ System electric vehicles. Any other use renders the Limited Warranties expressed herein and all implied warranties null and void and same are hereby excluded.

**ALSO EXCLUDED FROM THIS LIMITED WARRANTY ARE ANY AND ALL INCIDENTAL OR CONSEQUENTIAL DAMAGES INCLUDING, BUT NOT LIMITED TO, LOSS OF USE OR REVENUE, LOSS OF TIME, INCONVENIENCE OR ANY OTHER ECONOMIC LOSS.**

Damage not resulting from a defect in material or workmanship or that occurs due to abuse or neglect (including failure to provide reasonable and necessary maintenance), accident or alteration is excluded from this limited warranty.

Some states allow neither limitation on the duration of an implied warranty nor exclusions or limitations of incidental or consequential damages. Therefore, the above limitations or exclusions may not apply to you.

This warranty gives you specific legal rights, and you may also have other rights, which vary from state to state.

For further information contact WARRANTY SERVICES, CLUB CAR, INC., P.O. Box 204658, Augusta, Georgia, 30917-4658, U.S.A., 706-863-3000.

## Your Comments Are Appreciated

*Please select your category:*

- Distributor/Dealer                       Technician  
 Individual Owner                       Golf Course Superintendent  
 Other: \_\_\_\_\_

*In order to help us better serve you, please rate this publication in the following categories:*

	Poor	Fair	Average	Good	Excellent
1. Ease of Understanding	<input type="checkbox"/>	<input type="checkbox"/>	<input type="checkbox"/>	<input type="checkbox"/>	<input type="checkbox"/>
2. Ease of Finding Information	<input type="checkbox"/>	<input type="checkbox"/>	<input type="checkbox"/>	<input type="checkbox"/>	<input type="checkbox"/>
3. Clarity of Illustrations	<input type="checkbox"/>	<input type="checkbox"/>	<input type="checkbox"/>	<input type="checkbox"/>	<input type="checkbox"/>

*Comments/Suggestions:*

---

---

---

---

---

---

---

---

---

---

---

---

---

---

---

---

---

Please fax a copy of this page to (706) 228-2662.

Thank You!  
Club Car Technical Publications Department



**Manual No. 102318602**  
**Edition Code 0802C0203A**

**Golf Cars/Electric**  
Club Car, Inc., P.O. Box 204658  
Augusta, GA 30917-4658

