

UHS Propane Burnisher
PE400BU



Pioneer Eclipse®

NOTICE

Proper maintenance is necessary with all propane powered floor machines. Following the scheduled maintenance procedures found in your operation manual will provide many years of uninterrupted service.



In addition to the scheduled maintenance procedures listed it is recommended to have your machine serviced by certified service personnel every three months. This service should include an emissions check.

DANGER! For your safety, if you smell propane:

1. Extinguish any open flame.
2. Open window.
3. Do not touch electrical switches.
4. Immediately call your propane supplier.

DANGER! Do not store or use gasoline or other flammable vapors and liquids in the vicinity of this or any other appliance.

Record This Important Information		
Date of Purchase	_____	
Purchased From	_____	
Address	_____	
City	State	Zip
_____	_____	_____
Phone	Contact	_____
_____	_____	_____
Machine Model	_____	
Machine Serial Number	_____	
Important Phone Numbers		
Medical Emergency	_____	
Police	_____	
Fire Department	_____	

In this Operation Manual you will find three statements that you must read and observe to ensure safe operation of this machine.

DANGER! indicates that the possibility of severe bodily injury or death can occur if DANGER! statements are ignored. Read and observe all DANGER! statements included in the Operation Manual and attached to the machine.

WARNING! indicates that the possibility of bodily injury to the operator and other people can occur if WARNING! statements are ignored. Read and observe all WARNING! statements included in the Operation Manual and attached to the machine.

CAUTION! indicates that the possibility of damage to the machine or other property can occur if CAUTION! statements are ignored. Read and observe all CAUTION! statements included in the Operation Manual and attached to the machine.

Contents

Quick Reference Specifications.....	1	Maintenance	13
Safety Precautions.....	2	Oil Level Inspection.....	13
Refueling and Storage of Fuel Cylinders.....	4	Oil Change.....	13
Operator Responsibility.....	4	Oil Filter Replacement.....	13
Machine Preparation.....	5	Spark Plug Inspection and Replacement.....	14
Unpacking the Machine.....	5	Air Filter Inspection and Replacement.....	14
Filling the LP Cylinder.....	5	Inspect Fuel Hose and Connections.....	14
Installing the LP Cylinder.....	5	Engine Dust Filter.....	15
Controls and Instruments.....	6	Check and adjust valve clearance/Retorque Heads.....	15
Engine Ignition Switch.....	7	Clean and lap valve-seating surface.....	15
Engine Throttle.....	7	Head Bolt Maintenance.....	15
Hour Meter/Tachometer.....	7	Cooling Fin Maintenance.....	15
Rok-Bak / Handle Adjustment.....	7	Inspect Drive Belt.....	15
Pad Change.....	8	Belt Maintenance.....	15
Fuses.....	8	Battery Maintenance.....	16
Wheel Adjustment.....	8	Machine Storage.....	16
How the Machine Works.....	9	Repacking the Machine.....	16
Pre-Operation Checklist.....	9	Transporting the Machine.....	16
LP Fuel Cylinder.....	9	Machine Specifications.....	17
Installing the LP Fuel Cylinder.....	9	Wiring Schematic.....	19
Starting the Machine.....	10	Connections.....	20
Burnishing.....	10	Engine Assembly.....	22
Idling and Stopping the Machine.....	10	Deck Sub-Assembly.....	24
Machine Troubleshooting.....	11	Handle Sub-Assembly.....	26
Scheduled Maintenance Chart.....	12	Main Assembly.....	28
		Regulator and Solenoid Assembly.....	30
		Small Off Road Engine Certification Warranty Form.....	33
		Warranty.....	34
		Safety Awareness Form.....	35

Quick Reference Specifications:

Capacities:

- Engine Oil:
 - Filter not removed: 1.6qt. (1.5L)
 - Filter removed: 1.8qt. (1.7L)
 - Engine Oil Type: SAE30 with API Service Classification SH or SJ

Routine Maintenance Parts:

- Engine Dust Filter: MP035200
- Engine Oil Filter: KA490657007
- Engine Primary Air Filter (Paper Element): KA110137049
- Engine Air Pre-Cleaner (Foam Element): KA110137046
- Spark Plug: KA920702112
- Battery: MP362200
- Drive Belt: MP8070 (21")
MP041000 (28")
- Fuses:
 - 20A: SS2570
- Pads:
 - 21" Blue Blend: PDDB06021
 - 21" Natural Poly-Blend: PDNP02021
 - 21" Thermal Thunder: PDTT01421
 - 21" White Lightning: PD010021

 - 28" Blue Blend: PDDB06028
 - 28" Natural Poly-Blend: PDNP02028
 - 28" Thermal Thunder: PDTT01428
 - 28" White Lightning: PD010028

Your Authorized Amano Pioneer Eclipse Distributor _____

Authorized Amano Pioneer Eclipse Distributor Telephone Number _____

Amano Pioneer Eclipse: 1-336-372-8080

Safety Precautions

Anyone operating the machine should read the following carefully and be informed of potentially dangerous operating conditions. Operators should be familiar with the location and use of all safety devices on the machine. Do not use the machine if it is not in proper operating condition, and report any damage or operation faults immediately.

DANGER! Operate this machine in a well-ventilated area. It is the responsibility of the machine operator, machine owner, and the site manager to ensure that the air exchange system where the machine is to be used is in compliance with local building codes and is operating properly. Failure to operate this machine in a well-ventilated area could lead to sickness, injury, or death from carbon monoxide (CO) exposure.

DANGER! This machine emits CO, which is colorless, odorless, non-irritating gas. The first symptoms of CO exposure include headache, drowsiness, dizziness, and nausea. If you should experience any of these symptoms while operating the machine, shut off the machine and go outside to get fresh air. Have the machine tested for CO emissions by a qualified service technician before using it again.

DANGER! Prolonged or high exposure to CO may result in vomiting, confusion, and collapse in addition to loss of consciousness and muscle weakness. If such symptoms occur, call 911 for emergency medical attention. If you have experienced these symptoms, **DO NOT** operate this machine or any other propane machine again until cleared by a physician. Excessive exposure to CO can result in death.

DANGER! Propane is a highly flammable fuel. If you smell propane, shut off the machine immediately and take it outside the building. **DO NOT** use the machine again until a qualified service technician has corrected the propane leak. **DO NOT** use or allow another person to use an ignition source such as a cigarette lighter near the propane machine. **DO NOT** smoke near the propane machine. **DO NOT** vent a propane cylinder inside a building. **DO NOT** store propane cylinders inside a building.

DANGER! This machine has parts, including the pad assemblies, that can cause severe injury if these parts are contacted while they are moving. **DO NOT** allow any part of the body or clothing to come in contact with these parts while they are moving. **DO NOT** try to change attachments while the machine is running. **DO NOT** allow other people to come near the machine while it is in operation. **DO NOT** allow the machine to run unattended. **DO NOT** leave the machine in a place where unauthorized or untrained personnel could use the machine. **DO NOT** run the machine with the pad off center, damaged or missing. **DO NOT** run machine with unsecured guards and shields.

DO NOT operate the machine if the machine has loose parts.

DANGER! Federal law and California State law prohibits the following acts or the causing thereof: (1) the removal or rendering inoperative by any person other than for purposes of maintenance, repair, or replacement, of any device or element of design incorporated into any new engine for the purpose of emission control prior to its sale or delivery to the ultimate purchaser or while it is in use, or (2) the use of the engine after such device or element of design has been removed or rendered inoperative by any person.

Among those acts presumed to constitute tampering are the acts listed below: **DO NOT** tamper with the original emission related part.

- Throttle body and internal parts
- Spark plugs
- Magneto or electronic ignition system
- Air cleaner elements
- Crankcase
- Cylinder heads
- Breather chamber and internal parts
- Intake pipe and tube
- Regulator
- Fuel lock-off

WARNING! Overfilled or liquid withdraw cylinders can damage the fuel system and create a fire hazard. **DO NOT** overfill the cylinder or use a liquid withdraw cylinder on the machine. If the regulator freezes stop the burnisher and take the cylinder outside. Inspect cylinder, if a vapor withdraw cylinder, use gloves or pliers to open bleeder valve and purge cylinder until only vapor is escaping. If it is a liquid withdraw cylinder, replace with a vapor withdraw cylinder. Both cylinders are shown below.

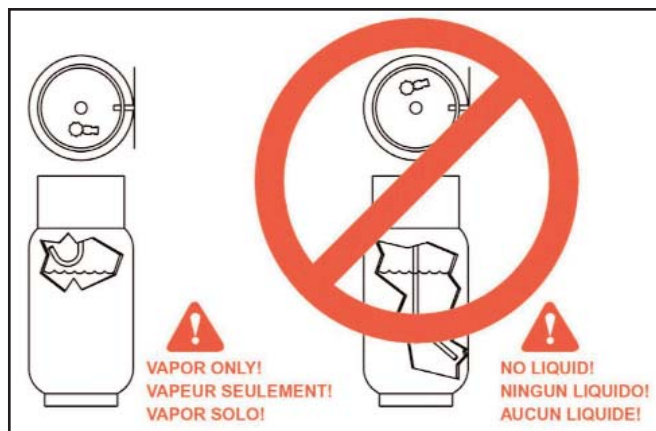

WARNING! Modifications or alterations to this machine can lead to personal injury or damage to the machine. **DO NOT** make unauthorized modifications or alterations to this machine. Amano Pioneer Eclipse assumes no liabilities for injury or damage resulting from an unauthorized modification or alteration to the machine. Any unauthorized modification or alteration to this machine voids all warranties.

WARNING! The muffler and the engine become hot enough while the machine is in operation, and for a long time after the machine is shut off, to cause severe burns. **DO NOT** touch these parts of the machine until they have cooled.

WARNING! Injury can occur to the eyes and body while using the machine. Safety goggles, safety shoes, and safety clothing are recommended while operating the machine.

WARNING! Continuous exposure to high noise levels can cause hearing loss. Hearing protection is recommended while the machine is in operation.

WARNING! Machine vibration may cause tingling or numbness in the fingers or hands. Gloves are recommended to reduce machine vibration. If tingling or numbness persists, shut off the machine. If the vibration is caused by loose parts, adjust or tighten these parts before using the machine again.

CAUTION! A dirty engine filter can cause overheating. Check and replace following recommended maintenance schedule.

CAUTION! Overheating can be caused by insufficient or low oil. Check oil before each use, and fill or change as needed.

CAUTION! Never over-fill engine with oil. Over-filling could cause irreparable damage to the engine.

CAUTION! Overheating can be caused by dirty oil. Check oil before each use and change regularly following recommended maintenance schedule.

CAUTION! Do not engage starter for more than 5 seconds. Allow a 10 second cool-down period for second failed start-up attempt.

CAUTION! Perform all recommended scheduled maintenance. Regular maintenance of your propane powered floor machine is necessary to keep it in safe working condition.

CAUTION! DO NOT operate machine unless trained and authorized. **DO NOT** operate machine unless you have read and understand the operation manual. **DO NOT** operate machine in flammable or explosive areas.

CAUTION! Before starting machine ensure all safety devices are in place and functioning properly. Before starting machine check for proper operation.

CAUTION! When using machine, go slowly on inclines or slippery surfaces. Use care when operating machine in reverse.

CAUTION! When servicing machine, stay clear of moving parts. **DO NOT** wear loose clothing when working on machine. Block machine wheels before raising or jacking up machine. Use hoist stands that will support the weight of the machine. Wear eye and ear protection when using pressurized air or water. Disconnect battery connections before servicing machine. Use only replacement parts supplied by Amano Pioneer Eclipse or an Amano Pioneer Eclipse Authorized Distributor or Service Center.

CAUTION! When loading or unloading machine onto or off a truck or trailer, turn machine OFF. Only use a truck or trailer that will support the weight of the machine to transport. **DO NOT** push the machine onto or off a truck or trailer unless the load height is 15 in (380mm) or less from the ground. Block machine wheels when transporting. Tie the machine down securely to truck or trailer when transporting.

This machine is manufactured for commercial use only.

This machine is designed and manufactured for indoor use in burnishing wax coated hard floor surfaces. Amano Pioneer Eclipse does not recommend use of this machine in any environment other than an indoor environment. This propane powered floor machine is designed and manufactured for commercial floor burnishing only. This machine is designed to burnish most modern types of floors including composition tile, stone, marble, terrazzo, and resilient floor covering, and some coated wood floors. Even though NFPA 11.13.2.3 says..."the use of floor maintenance machines in buildings frequented by the public, including the times when such buildings are occupied by the public, shall require the approval of the authority having jurisdiction." Amano Pioneer Eclipse suggests usage when occupancy of a given work area is minimal.

These machines should not be used

- In nursing homes, hospitals, day-care centers, etc. that are occupied.
- By unqualified or untrained personnel.
- Unless properly maintained and adjusted.
- On areas with obstructions such as thresholds, floor outlet boxes, etc.
- In areas where loose debris or other objects are present.
- In rooms and areas without proper ventilation.

Refueling and Storage of Fuel Cylinders

This machine uses a 20lb (9.1kg) capacity aluminum or steel cylinder, which meets the DOT 4E240 standards. These cylinders are also listed by UL. In addition, the steel cylinder meets European TPED specifications and is CE compliant. Filling should be done ONLY by a qualified propane dealer. **FILL THROUGH THE SERVICE VALVE ONLY.** A properly filled cylinder should not exceed 80% of the rated capacity.

DO NOT attempt cylinder repair. Return the cylinder to your propane dealer if repair is necessary. Please note that DOT regulations prohibit shipping of cylinders after the cylinder has been filled with propane.

When not in use, cylinders should always be stored outside in an upright position in a secure, tamper-proof, steel mesh storage cabinet. The cabinet may be located next to the building, but with at least five feet (1.5 m) of space between the cabinet and the nearest building opening (door or window).

The cylinder to be used on this machine is a vapor withdraw cylinder. **A liquid withdraw cylinder is not to be used with this machine.** The use of a liquid withdraw cylinder on a vapor withdraw system could freeze the

regulator and create a fire hazard. The National Fire Protection Association (NFPA) Standard for Storage and Handling of LP Gas is the appropriate authority for safe propane use. A copy of this publication is available through the National Fire Protection Association (1-800-344-3555) or www.NFPA.org.

Operator Responsibility

The operator is responsible for performing the recommended daily maintenance and checkups of the machine to keep it in good working condition. The operator must inform the service mechanic or supervisor when recommended maintenance procedures are required as described in the MAINTENANCE section of this manual.

Read this manual carefully before operating this machine.

FOR SAFETY: **DO NOT** operate machine before reading and understanding the operation manual.

Check the machine for shipping damage.

Keep your machine regularly maintained by following the maintenance information in this manual. We recommend taking advantage of a service contract from your Amano Pioneer Eclipse Authorized Distributor or Service Center. Order parts and supplies only from an Authorized Amano Pioneer Eclipse Distributor. Use the parts illustration section of your manual when ordering parts.

During and after operation, perform the recommended daily and hourly procedures outlined in the Maintenance Chart.

Machine Preparation

Unpacking the Machine

The machine is shipped boxed on a wooden pallet. To unpack machine:

1. Cut and remove bands holding the box to the pallet.
2. Remove staples attaching the box to the platform at the bottom edge of the box.
3. With two people, one at either end of the box, lift box straight up and off machine.
4. Cut and remove bands securing the machine to the pallet.
5. Remove back brace.



6. Remove bolt, nut, and washer from handle.

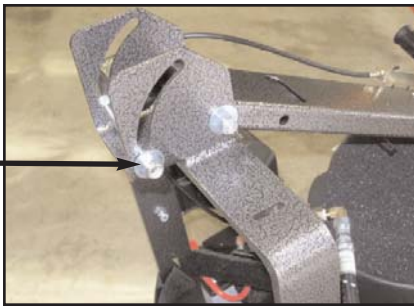

7. Rotate handle to the user position. Then insert the bolt through the handle bracket and handle top.



8. Place the washer and nut on the bolt. Do not over tighten the lock nut. The nut should be tightened as to allow the handle movement for pad change, but still not move during normal use.

9. Connect the battery cables to the battery.
NOTE: Connect the red cable to the (+) post and the black cable to the (-) post.
10. Check machine fluid levels (engine oil). See *Maintenance* section.
Note: If machine was shipped by airfreight, add engine oil.
11. Carefully back the machine off of the pallet.

Filling the LP Cylinder

This machine uses the 20 lb (9.1 kg) capacity cylinder, which meets the D.O.T. 4E240 standards. These cylinders are also listed by UL. In addition, the steel cylinder meets European TPED specifications and is CE compliant. Filling should be done **ONLY** by a qualified propane dealer. A properly filled cylinder should not exceed 80% of the rated capacity. Do not overfill the cylinder or use a liquid withdraw cylinder on the machine. The use of a liquid withdraw cylinder on a vapor withdraw system could freeze the regulator and create a fire hazard.

Installing the LP Cylinder

Place the Safe-Fill[®] cylinder on the cylinder platform at the back of the machine. Connect the fuel hose coupling to the service valve by turning to the right (clockwise). **HAND TIGHTEN ONLY!** Make sure coupling is not cross threaded and check for leakage by noting any propane odors immediately after cylinder is connected. Finally, secure the tank to the machine using the adjustable strap. Remove slack by pulling on the loose end and secure back to strap.

TO REMOVE THE LP CYLINDER, reverse the above procedure. Always connect or change cylinders in a well-ventilated area.

Machine Components

Controls and Instruments

Engine Throttle

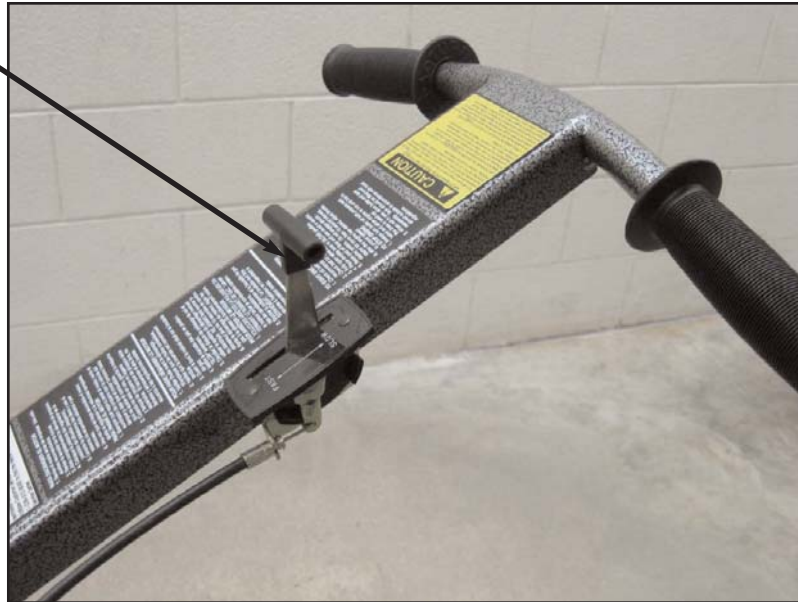

Key Switch

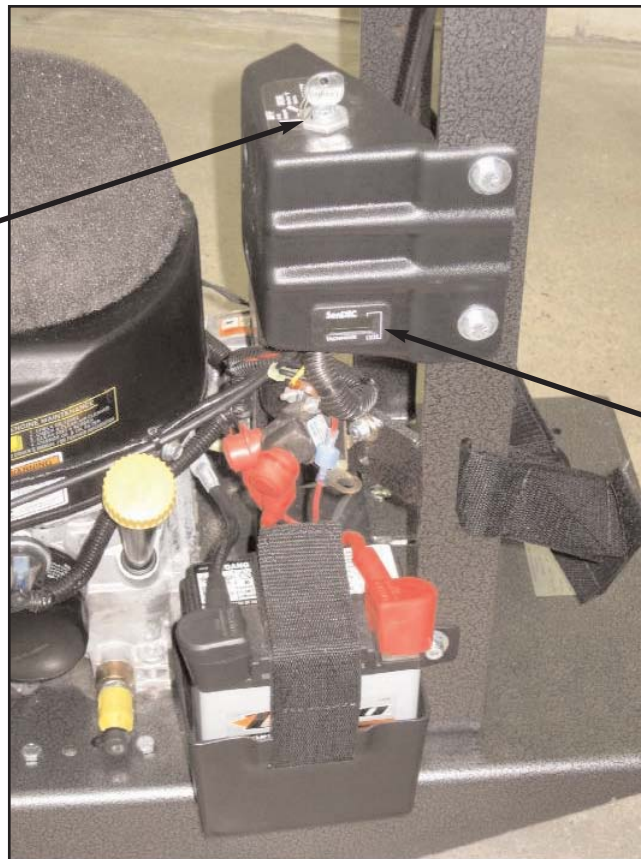

Hour Meter

Engine Ignition Switch

This machine features a key switch ignition.

Start: Turn the key all the way clockwise or START to engage the engine starter motor. Once the engine starts release the key.

Note: Always start this machine with the engine throttle in the idle or "slow" position.

Run: This is the position of the key while the engine is running.

Off: Turn the key to the "OFF" position to stop the engine from running.

Note: For safety, always close the propane cylinder valve to stop the engine and then turn the key switch to the "OFF" position.



Engine Throttle

The engine throttle controls the engine speed. To increase engine speed, move the hand lever forward. For idle position, pull the lever back.

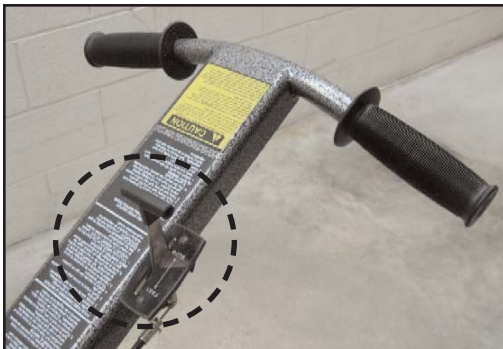

Hour Meter / Tachometer

The hour meter / tachometer records the number of hours the machine has been powered ON. The hour meter reading is used to mark recommended maintenance intervals. It also displays the engine speed. This meter displays hours when the machine is turned OFF and engine speed when the machine is turned ON.



Rok-Bak / Handle Adjustment

1. The height of the handle can be adjusted by raising or lowering the handle.
2. If necessary, use a wrench to loosen the nut that retains the handle in the adjustment bracket.



3. To place this machine in the Rok-Bak position turn the engine OFF.
4. Raise the handle to the full-up position.
5. Lift up on the front of the deck, rocking the machine back until it rests on the handle grips.



6. When lowering the machine down, do not drop the machine. Slowly lower the machine to the floor until the wheels are on the ground.

Pad Change

1. Close the valve on the propane cylinder, allow the engine to stop and turn the machine OFF.
2. Remove the propane cylinder.
3. Raise the handle to the full-up position (about a 45° angle).
4. Rock the machine by lifting up on the front of the machine until it rests on the handle grips.



5. Remove centering device and inspect pad. If pad has worn less than 1/4" (6mm), replace it.



CAUTION! Carefully inspect the pad holder for cracks or damage. Replace if necessary.

WARNING! A damaged pad holder rotating at high speeds may be an extreme hazard if it should come apart.

Fuses

The machine's electrical circuit is protected by a fuse, which stops the flow of current in the event of a circuit overload. Once a fuse blows, it must be replaced. If the overload that caused the fuse to fail is still present, the new fuse will fail and the problem must be corrected. **DO NOT** bypass any fuse. The ignition fuse is located on the side of the starter switch panel.

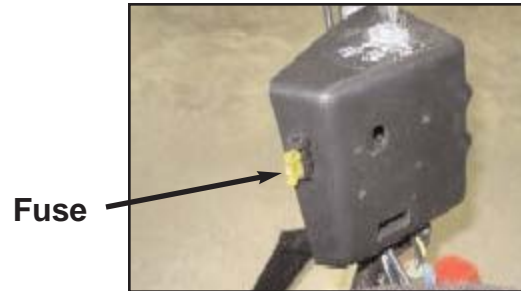

Wheel Adjustment

1. Close the valve on the propane cylinder, allow the engine to stop and turn the machine OFF.
2. Remove the propane cylinder.
3. Raise the handle to the full-up position (about a 45° angle).
4. Rock the machine by lifting up on the front of the machine until it rests on the handle grips.
5. Remove the clevis pin that retains each wheel and relocate to the desired wheel position.

NOTE: To increase pad pressure (more aggressive) move wheels to rear of machine. To decrease pad pressure (less aggressive) move wheels toward the front of machine.



How the Machine Works

This machine is a propane burnisher that has a pad driver that is belt driven directly from the engine crank shaft.

Pre-Operation Checklist

- Check the engine oil level. Add oil if needed. Refer to *Maintenance*.
- Inspect the engine dust filter and clean off any debris or dust buildup. Refer to *Maintenance*.
- Inspect the burnishing pad and replace, if necessary. Refer to *Maintenance*.
- Inspect the pad holder for cracks or damage! Replace if necessary. Refer to *Maintenance*.

WARNING! A DAMAGED PAD HOLDER ROTATING AT HIGH SPEEDS MAY BE AN EXTREME HAZARD IF IT SHOULD DISINTEGRATE.

- Inspect air filter. Clean or replace if necessary. A dirty air filter could lead to elevated levels of carbon monoxide. Refer to *Maintenance*.
- Inspect the drive belt. Replace if necessary. Refer to *Maintenance*.
- Check the machine for leaks or loose fasteners.

LP Fuel Cylinder

This machine uses the 20 lb (9.1 kg) capacity cylinder, which meets the D.O.T. 4E240 standards. These cylinders are also listed by UL. In addition, the steel cylinder meets European TPED specifications and is CE compliant. Filling should be done **ONLY** by a qualified propane dealer. A properly filled cylinder should not exceed 80% of the rated capacity. Do not overfill the cylinder or use a liquid withdraw cylinder on the machine. The use of a liquid withdraw cylinder on a vapor withdraw system could freeze the regulator and create a fire hazard.

Installing the LP Cylinder

1. Before bringing a propane cylinder indoors, always check it for over-filling.
2. Place the tank on the machine and secure with the retaining strap. Remove slack by pulling on the loose end of the strap and secure back to strap. Connect the fuel hose coupling to the service valve by turning clockwise. **HAND TIGHTEN ONLY**. Make sure coupling is not cross threaded and check for leakage by noting any propane odors immediately after cylinder is connected. (It is sometimes easier to install if the connection to the service valve is made before strapping the cylinder in place.)

CAUTION! Always open service valve slowly to allow pressure to equalize in hoses. Opening quickly may cause the flow check valve to engage, limiting fuel flow.

TO REMOVE THE SAFE-FILL CYLINDER, reverse procedure. Always connect or change cylinders in a well ventilated area.



Only Use a Vapor Cylinder!

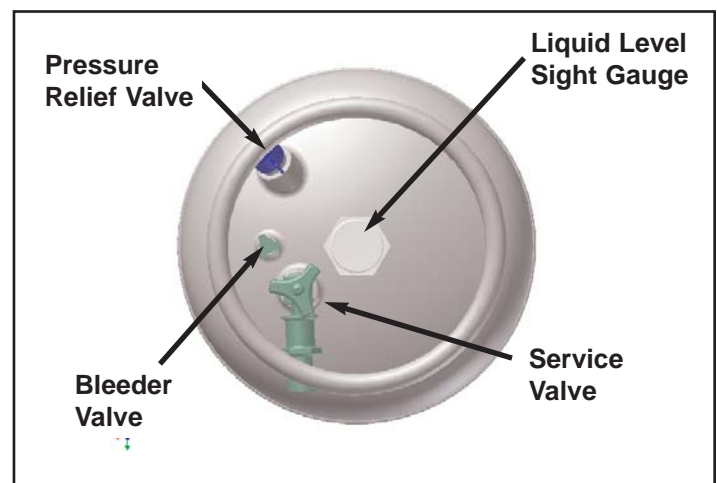
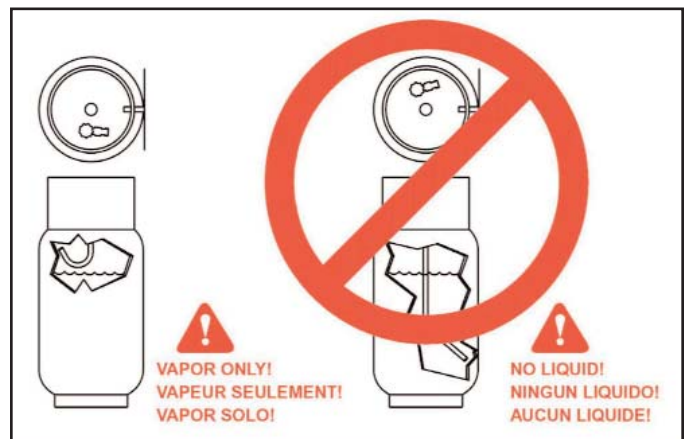

Starting the Machine

1. Check oil and fuel levels.
2. Check and clean engine dust filter.

CAUTION! Never run continuously for more than 1 hour without cleaning or changing engine dust filter.

3. Check carburetor air filter. Change if necessary. (See “Scheduled Maintenance”)
4. Turn propane service valve counterclockwise to open.

CAUTION! Always open service valve slowly to allow pressure to equalize in hoses. Opening quickly may cause the flow check valve to engage, limiting fuel flow.

5. Allow machine to tilt backward (pad off floor) and move throttle to SLOW position.
6. With the engine throttle lever in the idle position, engage the starter by turning the key switch to the starting position for approximately 5 seconds. If the engine does not start, release the key switch for 10 seconds, then try to start again in another 5 seconds.
7. After the engine has started, move the throttle forward approximately halfway and allow the engine to warm up for approximately 30 seconds.

WARNING! Catalytic mufflers require a few minutes to warm up before effectively removing harmful emissions. Make sure of proper ventilation during this warm-up period!

Burnishing

1. After engine has started, allow approximately 30 seconds for the engine to warm up.
2. Advance the throttle to operating speed.
3. Lower the burnishing head to the floor while moving the machine forward slowly.

CAUTION! Do not run the burnisher without moving the machine. If the machine is allowed to run in one spot, damage to the floor may occur.

4. To stop burnishing, push down on handle to raise the burnishing head off the floor.

CAUTION! DO NOT add weight to the burnisher head.

CAUTION! DO NOT lift up on the handle to add pressure while burnishing.

Note: To not comply with any of the **CAUTION!** statements could cause the engine to overheat and/or damage the padholder or drive components.

It is recommended to start burnishing on the right side of the aisle, turn and come back down the aisle in the opposite direction, overlapping the previous path slightly. Continue this pattern until the floor area to be burnished has been covered with the last pass being on the right side of the machine. The forward speed is generally at normal walking speed.

5. When done burnishing, push the machine to the desired location. Turn off the LP cylinder service valve. When the fuel is depleted and the engine stops, turn the key switch OFF.
6. Remove the LP cylinder and store properly. Refer to *Refueling and Storage of Fuel Cylinders*.

Idling and Stopping the Machine

DANGER! Allowing the engine to idle excessively will increase carbon monoxide emissions!

To stop the engine, close the service valve on the fuel cylinder by turning it clockwise (the engine will stop when the fuel in the lines is used up). Once the engine stops, turn the keyswitch off.

Machine Troubleshooting

Problem	Possible Cause	Solution	
Engine is hard to start	Propane cylinder is not properly connected.	Check connection and open service valve slowly.	
	Battery is weak.	Charge battery or replace.	
	Oil level is to low.	Check the oil level and add if needed.	
	Insufficient vacuum.		Place the engine throttle in the idle "slow" position.
			Check the regulator vacuum hose for breaks, pinched hose, or a bad connection.
	Coil air gap out of adjustment.	Adjust coil air gap (Check FS481V Service Manual). Contact an APEC Certified Technician.	
	Spark plug or head bolts loose.	Retorque (Check FS481V Service Manual). Contact an APEC Certified Technician.	
Head gasket blown or valves need adjusting	Replace head gasket, adjust valves and replace if necessary (Check FS481V Service Manual). Contact an APEC Certified Technician.		
Engine will not start	Propane cylinder is empty.	Install properly filled cylinder.	
	Oil level is to low.	Check the oil level and add if needed.	
	Machine is in the pad change position.	Lower the machine to operating position.	
	Main fuse is blown.	Inspect fuse and if blown replace	
	Insufficient vacuum.		Place the engine throttle in the idle "slow" position.
			Check the regulator vacuum hose for breaks, pinched hose, or a bad connection.
	Head gasket blown or valves need adjusting	Replace head gasket, adjust valves and replace if necessary (Check FS481V Service Manual). Contact an APEC Certified Technician.	
	Wires broken or disconnected.	Reconnect or replace wires. Contact an APEC Certified Technician.	
	Coil(s) defective.	Replace coil(s) (Check FS481V Service Manual). Contact an APEC Certified Technician.	
	Spark plug gap is incorrect.	Adjust gap to 0.025" (.64mm)	
Spark plug defective.	Replace spark plug.		
Engine lacks power	Insufficient vacuum.	Place the engine throttle in the idle "slow" position.	
		Check the regulator vacuum hose for breaks, pinched hose, or a bad connection.	
	Dirty air filter(s).	Clean or replace the primary filter (paper element).	
		Clean or replace the secondary filter (foam element).	
	Governor out of adjustment or malfunctioning.	Adjust governor and replace if necessary (Check FS481V Service Manual). Contact an APEC Certified Technician.	
	Head gasket leaking.	Replace head gasket (Check FS481V Service Manual). Contact an APEC Certified Technician.	
	No compression.	Worn piston ring(s) and/or cylinder head(s) require replacement (Check FS481V Service Manual). Contact an APEC Certified Technician.	
Fuel mixture is to lean.	Check and adjust fuel mixture if necessary. Contact an APEC Certified Technician.		
Valves need adjusting or replacing.	Adjust valves (Check FS481V Service Manual). Contact an APEC Certified Technician.		
Smell or burned rubber	Belt out of adjustment.	Check the automatic tensioner	
Machine vibrates	Loose fasteners.	Check the engine, tensioner, spindle, and pad holder fasteners. Tighten any fasteners that may be loose.	
	Pad is not centered on the pad holder.	Remove pad and re-center on padholder. Replace the pad with a new pad if necessary.	
	Padholder is out of balance.	Remove pad holder from the machine and clean both sides. Check for cracks or tears. Replace if necessary.	
Machine is burnishing too aggressively	Wheels are adjusted to far back.	Move both wheels forward in the wheel bracket.	
	Improper pads.	Only use recommended burnishing pads.	
Machine pulls to one side	Bent wheel bracket.	Replace wheel bracket.	
	Wheel is worn or a bad bearing.	Replace wheel.	
	Wheels are adjusted to far back.	Move both wheels forward in the wheel bracket.	
Engine stops running	Propane cylinder is empty.	Install properly filled cylinder.	
	Engine oil level is to low.	Check the oil level and add if needed.	
	Dirty air filter.	Clean both filters or replace if necessary.	

Scheduled Maintenance

Operation	Interval							
	Daily	First 8 Hrs.	Every 50 Hrs.	Every 100 Hrs.	Every 200 Hrs.	Every 300 Hrs.	Every 400 Hrs.	Every 500 Hrs.
Check & add engine oil	●							
Check for loose or lost fasteners	●							
Check for oil leakage	●							
Inspect fuel hose and connections	●							
Clean Engine dust filter	●							
Inspect pad holder	●							
Change Engine Oil		●	●					
Change engine oil filter		●		●				
Check & clean air cleaner paper element				●				
Check & clean air cleaner foam element				●				
Inspect battery and battery connections				●				
Replace air cleaner paper element					●			
Replace air cleaner foam element							●	
Inspect, clean, & re-gap spark plugs, Replace if necessary				●				
Check & adjust valve clearance.* Retorque heads.*						●		
Clean & lap valve seating surface.*						●		
Check engine emissions*								●
Clean cooling fins			●					
Inspect drive belt				●				
Inspect burnishing head assembly			●					
Replace drive belt	As Required							
* Check FS481V Service Manual. Contact Amano Pioneer Eclipse Certified Technician.								

Maintenance

Oil Level Inspection

1. Push machine to level surface.
2. Turn off LP cylinder and remove it.
3. Clean area around the oil gauge before removing it.
4. Remove the oil gauge and wipe it with a clean cloth.



5. The machine should be in an upright level position. If necessary, place a block under the back of the machine or apply weight to the front of the deck to maintain an upright, level position.
6. Insert the oil gauge into the tube, but do not tighten the oil gauge.
7. Check the oil level. It should be between the "FULL" and "ADD" marks on the oil gauge.

Note: If the oil level is near or below the "ADD" mark, remove the oil gauge and add enough engine oil to bring oil level to the "FULL" mark. (SH or SJ SAE30 Oil)

Note: If the oil level is too high, remove the excess oil by loosening the oil drain valve.

CAUTION! Do not fill above the "FULL" mark. Excess oil will cause a smoking condition and may cause the engine to overheat.

Oil Change

1. Change the oil after the first 8 hours of operation and every 50 hours thereafter.
2. Start and warm the engine so the oil will drain easily and completely. Push machine to a level surface. Stop the engine.
3. Turn off LP cylinder and remove it.
4. Remove cap on the end of oil drain valve.
5. Attach a piece of 1/2" tubing on the end of the oil drain valve (approx. 8" long).



6. Place a suitable container under the end of the oil drain hose.

WARNING! Be careful with hot oil being drained. It may be hot enough to cause severe burns.

7. Slowly turn the valve counter-clockwise, approximately 1/8 of a turn, then gently pull the valve outward to open the valve.

Note: In order for the oil to drain, it may be necessary to loosen the oil fill cap.

8. Push the oil drain valve inward and turn the valve 1/8 turn clockwise. Place cap back on the end of the valve.
9. Remove oil cap and add clean SH or SJ SAE 30 oil. Use 1.6 U.S. qt. (1.5 L) when the filter is not changed and 1.8 U.S. qt. (1.7 L) when filter is changed.
10. Screw in oil gauge. Reconnect the LP cylinder to the fuel hose.
11. Run the engine at low idle for 2 minutes. Check for leaks around the engine.
12. Stop the engine. Check the oil level (see *Oil Level Inspection* section).

Oil Filter Replacement

1. Place a suitable container underneath the oil filter.
2. Using a strap wrench or oil filter wrench, remove the oil filter. Turn the filter counter-clockwise to remove it.
3. Apply a thin coat of new oil or grease to the oil filter seal (A).
4. Install the new filter (**Amano Pioneer Eclipse part # KA490657007**) by turning it clockwise.
5. Turn the filter until the seal contacts the mounting surface (B) of the engine. Then, turn the filter BY HAND 3/4 turn more.

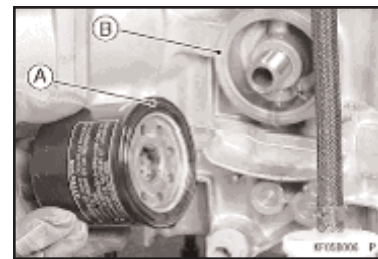

6. Reconnect the LP cylinder to the fuel hose.
7. Run the engine at low idle for 2 minutes. Check for leaks around the engine.
8. Stop the engine. Check the oil level (see *Oil Level Inspection* section).

Spark Plug Inspection and Replacement

1. Turn off LP cylinder and remove it.
2. Pull spark plug cap off of spark plug.
3. Remove spark plug by turning counter-clockwise and inspect it.

Note: If the plug is oily or has carbon build up on it, clean the plug using a high flash-point solvent and a wire brush or other suitable tool.

Note: If the spark plug electrodes are corroded or damaged, or if the insulator is cracked, replace the plug. **Use Only Amano Pioneer Eclipse part # KA920702112. Do not use any other spark plug!**

4. Measure the gap with a wire-type thickness gauge. The correct gap is .025 in (.635 mm). If the gap is incorrect, carefully bend the side electrode with a suitable tool to obtain the correct gap

- A: Insulator**
B: Center Electrode
C: Plug Gap
D: Side Electrode

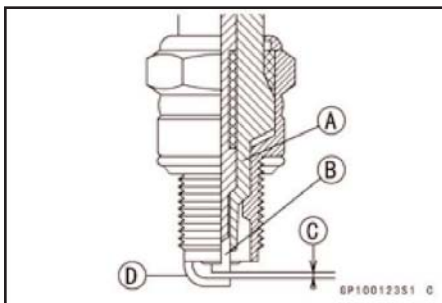

Air Filter Inspection and Replacement

1. Push machine to level surface.
2. Turn off LP cylinder and remove it.
3. Turn the two knobs 1/4 turn counter-clockwise and remove the filter cover.



4. Loosen clamp that retains filter and remove the air filter.

CAUTION! Do not wash the air cleaner filters. Do not oil the air filters. Do not use pressurized air to clean the air filters.

5. Inspect both primary and secondary air filters. If necessary, clean primary filter by lightly tapping and wipe seal ends with a clean cloth. If primary filter cannot be cleaned, is bent, or damaged, it must be replaced. **(Amano Pioneer Eclipse part # KA110137049)**. If secondary filter is dirty, do not attempt to clean it. Replace it with a new filter **(Amano Pioneer Eclipse part #KA110137046)**.
6. Check the intake hose for cracks or damage.
7. Install filters and replace cover.

Inspect Fuel Hose and Connections

1. Push machine to level surface.
2. Turn off LP cylinder and remove it.
3. Inspect hoses for abrasions and other signs of wear. Replace all worn or damaged hoses.
4. Check for gas leaks by spreading a soapy water solution around all connections while the LP cylinder is reconnected and the service valve is turned ON.



5. If a leak is detected, turn off the LP cylinder. If the leak is in a hose, replace it. If the leak is at a fitting, loosen and clean it. Apply pipe-sealing compound and re-tighten it.
6. Recheck for leaks using a soapy water solution. If leaks persist at fittings, replace them and recheck with a soapy water solution once more.

Engine Dust Filter

1. The engine dust filter should be cleaned each hour and after each use by shaking out the dust and then rinsing with mild detergent. The filter can also be vacuumed with a wet-dry vacuum.
2. Squeeze out the excess water (do not wring).
3. Allow the filter to air dry.

Note: Failure to maintain a clean engine filter will cause the engine to overheat. Also, it may cause the exhaust emissions to elevate to harmful levels. If necessary, replace with (APEC part number: MP035200).



Check and adjust valve clearance. Re-torque heads:

Refer to Kawasaki's FS481V service manual.

Clean and lap valve-seating surface:

Refer to Kawasaki's FS481V service manual.

Head Bolt Maintenance

Refer to Kawasaki's FS481V service manual.

Cooling Fin Maintenance

- A. Remove blower housing and any other shrouds.
- B. Clean the cooling fins as necessary using compressed air or pressure washer.
- C. Reinstall all housings and shrouds.

Inspect Pads and Pad Holders

1. Push machine to level surface.
2. Turn off LP cylinder and remove it.
3. Rock the machine back by lifting up the front of the machine until it rests on the handle grips. (See "Rok-Bak/Handle Adjustment" section.)
4. Remove centering device and inspect the pad. If the pad has worn less than 1/4" (6 mm), replace it.
5. Inspect the pad holder for cracks or damage. If

the pad holder does not have any damage proceed to step 9.

WARNING! A damaged pad holder rotating at a high rate of speed may be an extreme hazard if it should come apart.

6. If the pad holder needs to be removed, a 3/4" wrench will be required. Locate the wrench flats on top of the spindle shaft. With the spindle shaft secure, turn the pad holder counter clockwise until it is free of the spindle shaft.
7. Save the washer and/or spacer that is on the spindle shaft. Be sure they are in place when the pad holder is re-installed.
8. When threading the pad holder onto the spindle shaft, use the wrench to keep the shaft from turning. Be sure the pad holder is tight before proceeding.
9. Secure the pad with the centering device.
10. Lower the machine.

Belt Maintenance

1. Push machine to level surface.
2. Turn off LP cylinder and remove it.
3. Place the machine in the Rok-Bak position by lifting up on the front of the machine until it rests on the handle grips.
4. Rotate the pad drive and inspect the belt.
5. If cracks or excessive wear is present, the belt needs to be replaced.
6. To check for the proper tightness, squeeze the belt together. The belt should depress between 1/4" (0.6 cm) and 1/2" (1.3 cm).

To change belt:

(21") APEC Part Number: MP8070

(28") APEC Part Number: MP041000

- A. Remove the pad holder by holding the end of the shaft on the top of the machine with a 3/4" wrench and turn the pad holder counter-clockwise.
- B. Use the 3/4" wrench to turn the end of the spindle shaft on top of the machine while removing the old belt from the spindle pulley.
- C. Finish removing the belt from the engine pulley, if necessary.
- D. Check engine pulley for correct alignment with the spindle pulley. Check hardware attaching pulleys for proper tightness.
- E. Install the new belt onto the engine pulley.
- F. Reinstall the new belt onto the spindle pulley using the 3/4" wrench to turn the spindle clockwise. Make sure the belt is correctly placed on the idler pulley.
- G. Reinstall the pad holder onto the spindle shaft.
- H. Turn the machine upright in the burnishing position.
- I. Check belt for correct operation. Check all hardware for proper tightness.

Battery Maintenance

The battery supplied with this machine is a sealed, absorbed glass mat (AGM), maintenance free type. It never needs servicing. When battery replacement is necessary, use Amano Pioneer Eclipse part #: MP363200.

1. Push machine to level surface.
2. Turn off LP cylinder and remove it.



3. Disconnect the BLACK negative battery cable first. Disconnect the RED positive battery cable last.
4. Loosen battery-retaining strap.
5. Lift out old battery and replace with new battery.
6. Secure battery with battery-retaining strap.
7. Connect the RED positive battery cable first. Connect the BLACK negative battery cable last.

Note: Dispose of old battery in the proper manner. Most auto parts stores accept used batteries for recycling.

PROPOSITION 65 WARNING

- Battery posts, terminals, and related accessories contain lead and lead compounds, chemicals known to the State of California to cause cancer and reproductive harm.
- Batteries also contain other chemicals known to the State of California to cause cancer.
- Wash hands after handling.

Machine Storage

Only authorized, trained personnel should have access to propane cylinders and machines.

1. Remove propane fuel cylinder when not in use and store it outside in a storage cage in accordance with NFPA Handbook 58 CAN/CGAB149.2. Do not release or bleed propane inside the building. Please consult your local Fire Marshal to ensure that you are in compliance with local fire codes.
2. Store machine away from objects that may fall and damage it.
3. Never store machine or fuel cylinders near an open flame or heat-producing device.
4. Make sure machine is cleaned properly before storing.
5. Never store machine with cylinders installed, or store spare cylinders in an enclosed van or trailer.
6. Store machine in a dry location, temperature not to exceed 120°F (50°C).

Repacking the Machine

Refer to *Unpacking* and repack the machine using original packing materials and container. Store machine in a dry location, temperature not to exceed 120°F (50°C).

Transporting the Machine

When transporting a propane powered floor machine with the fuel cylinder installed, the cylinder should be securely fastened with the service valve closed and the machine should be secured in the vehicle. Any propane fuel cylinders not installed should be securely fastened to avoid movement and damage. Never store machine with cylinder installed or store spare cylinders in an enclosed van or trailer. It is a good practice to check propane cylinders for overfilling before transporting them. If overfilled, correct before loading them in the vehicle by venting the excess propane outside in a safe area using the bleeder valve.

Machine Specifications

<u>Starting:</u>	12VDC Battery
<u>Deck:</u>	Cast Aluminum
<u>Sound Level:</u>	< 89 dB(A)
<u>Vibration:</u>	Less than 2.5 m/s ²
<u>Engine:</u>	Kawasaki FS481V, 603cc Air Cooled
<u>Engine Speed:</u>	Idle - 1800-2000 rpm High Idle - 3400-3500 rpm
<u>Engine Oil:</u>	SAE 30 w/ API Service SH or SJ
<u>Engine Oil Capacity:</u>	
	Filter not removed - 1.6qt (1.5L)
	Filter removed - 1.8qt (1.7L)
<u>Engine Primary Air Filter (Paper Element):</u>	KA110137049
<u>Engine Air Pre-Cleaner (Foam Element):</u>	KA110137046
<u>Spark Plug:</u>	KA920702112
<u>Spark Plug Gap:</u>	0.025 in. (0.635 mm)
<u>LP Cylinder Type:</u>	20lb (9.1 kg) Vapor Withdraw

21" Machines

Pad Size:	21" (53.3 cm)
Pad Speed:	2000 RPM
Width:	24.5" (62.2 cm)
Length:	56" (142.4 cm)
Height:	39.5" (100 cm)
Weight:	187 lb (w/o tank) (85 kg)

28" Machines

Pad Size:	28" (71.1 cm)
Pad Speed:	1700 RPM
Width:	31.5" (80 cm)
Length:	61.5" (156.2 cm)
Height:	41.0" (104 cm)
Weight:	200 lb (w/o tank) (91 kg)

Wiring Schematic

082510

072910

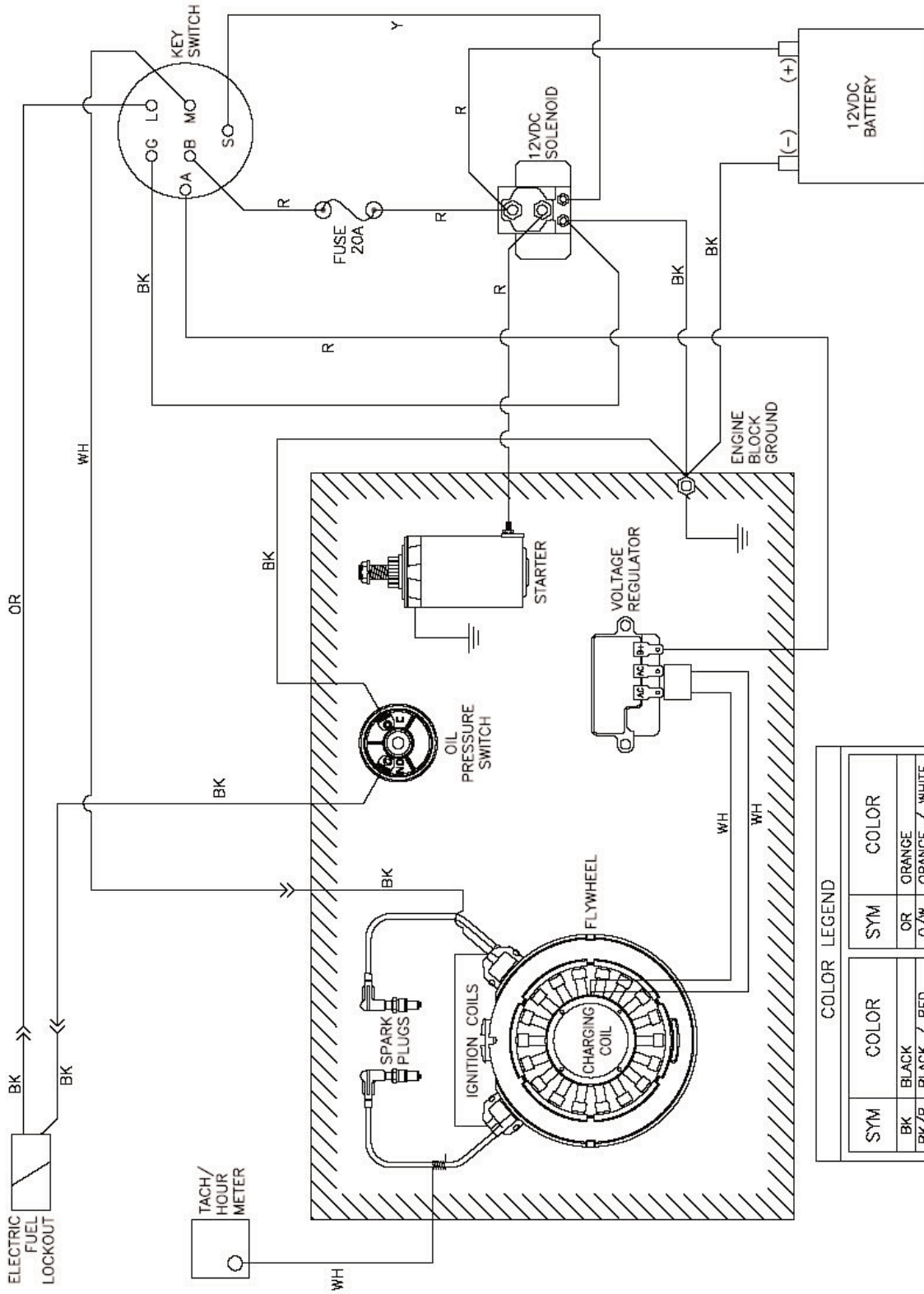

KEY SWITCH DIAGRAM

	A	L	B	S	I	G	M
OFF							●
RUN	●						●
START	●	●					●

COLOR LEGEND

SYM	COLOR	SYM	COLOR
BK	BLACK	OR	ORANGE
BK/R	BLACK / RED	O/W	ORANGE / WHITE
BK/Y	BLACK / YELLOW	P	PINK
BK/W	BLACK / WHITE	R	RED
BE	BLUE	R/BK	RED / BLACK
BE/R	BLUE / RED	R/Y	RED / YELLOW
BE/Y	BLUE / YELLOW	WH	WHITE
BR	BROWN	Y	YELLOW
GY	GRAY	Y/R	YELLOW / RED
GN	GREEN	Y/W	YELLOW / WHITE
GN/W	GREEN / WHITE		

RF032200

Connections

92810

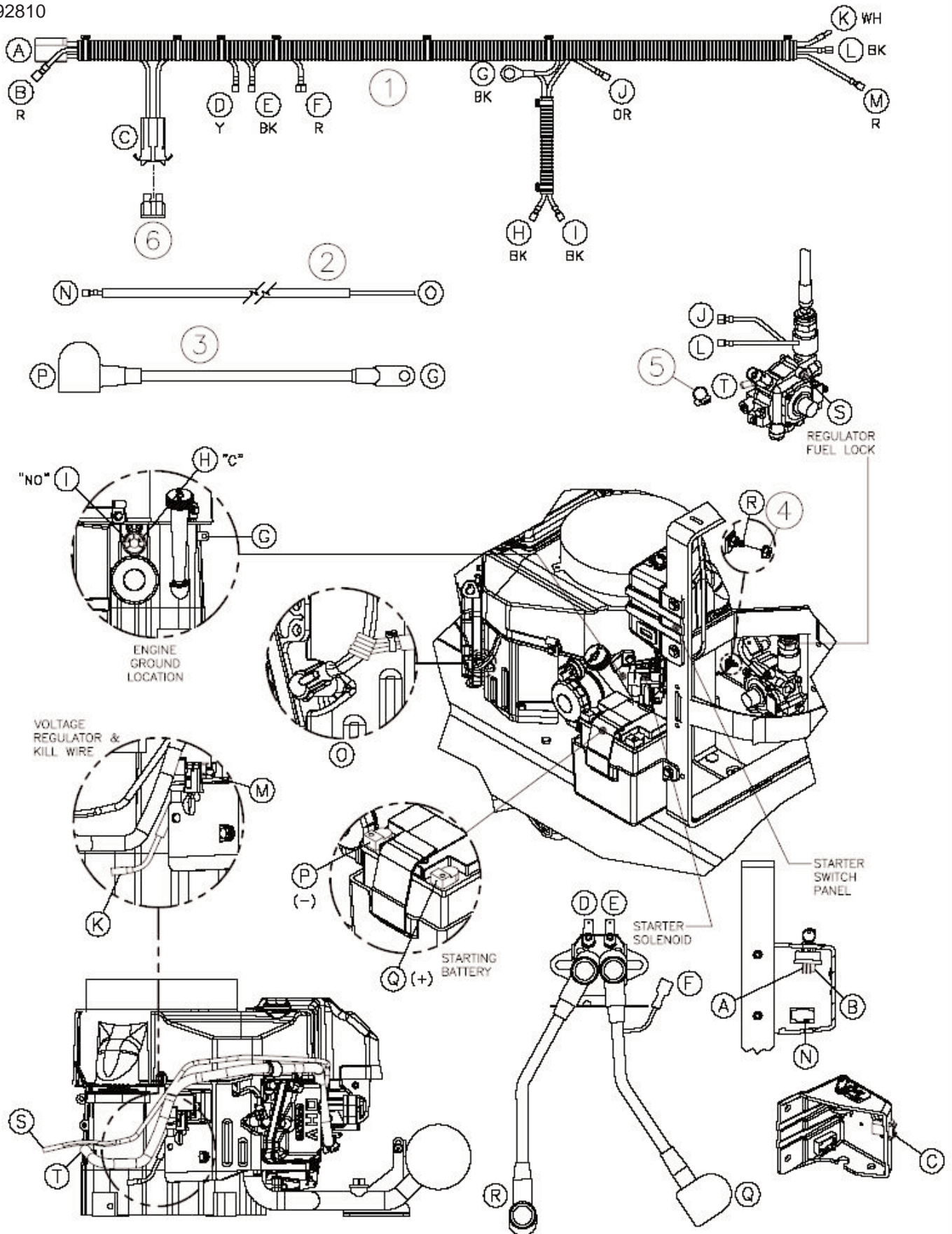

RF034500

092110

Connections Continued

Ref. Part #	Description	Qty.
1	MP368300 HARNESS, WIRING, BASE MODEL	1
2	MP368400 HARNESS, WIRING, METER, HOUR, 27"	1
3	MP368500 CABLE, BATTERY, NEG., 10"	1

Ref. Part #	Description	Qty.
4	NB9545 NUT, SPIN LOCK, 1/4-20	1
5	NB7282 CLAMP, HOSE, NO.38	1
6	SS2570 FUSE, 20 AMP, ATO	1

Engine Assembly

021711

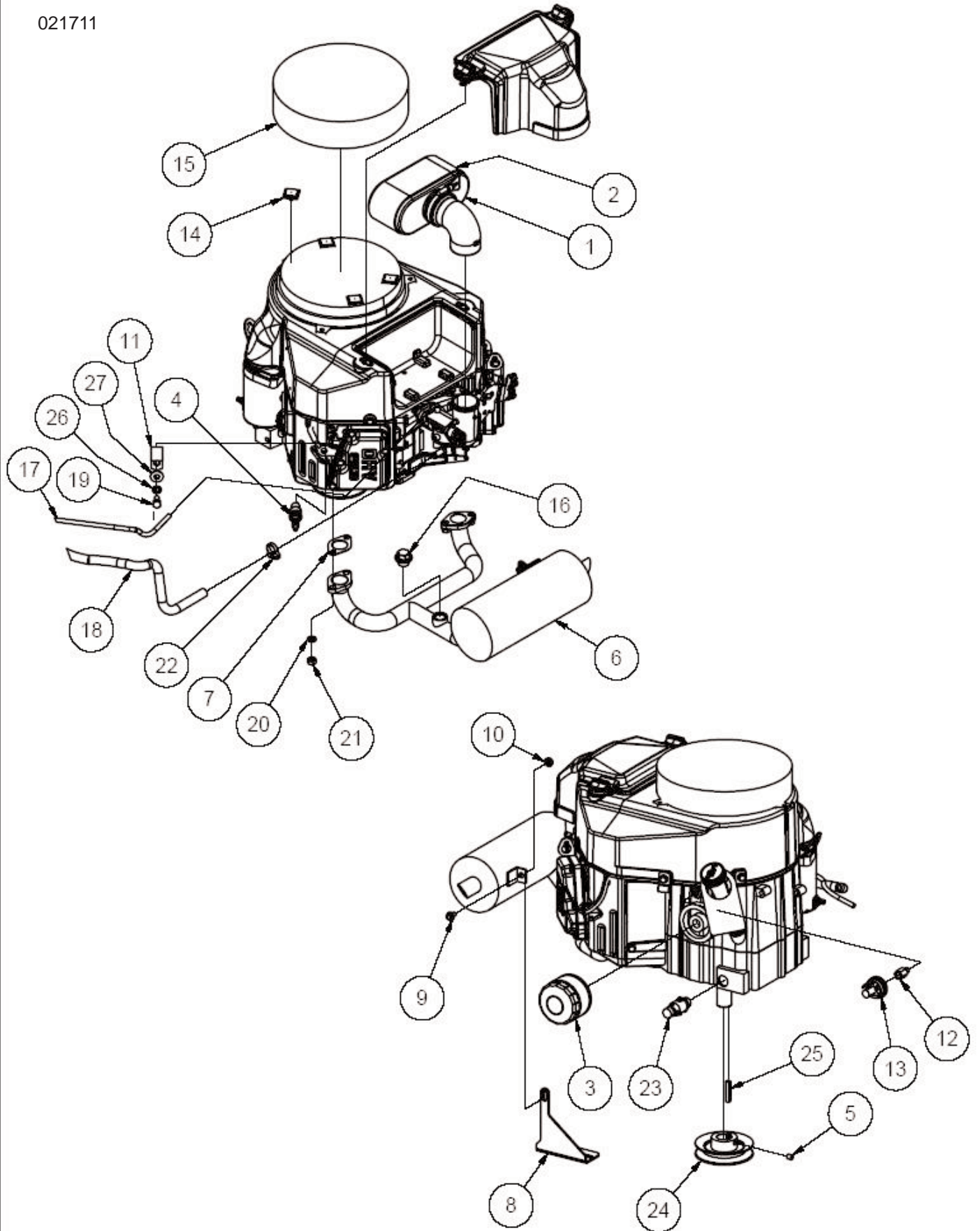

RF032300

020111

Engine Assembly Continued

Ref. Part #	Description	Qty.
1	KA110137049 ELEMENT, FILTER, AIR, FS481V	1
2	KA110137046 PRECLEANER, AIR, FS481V	1
3	KA490657007 FILTER, OIL, FS/FX481V	1
4	KA920702112 PLUG, SPARK, NKG, BPR4ES	1
5	NB2463 SCREW, SET, HEX SOCKET, 5/16-18 X 3/8	2
6A	MP368700 MUFFLER, w/o SHIELD, FS/FX481V	1
6B	MP365000 MUFFLER, w/o SHIELD, w/o CAT, FS/FX481V	1
7	KA110607016 GASKET, MUFFLER, 481V	2
8	MP120500 BRACKET, MUFFLER,	1
9	NB049300 SCREW, FLANGE, 1/4-20 X 1/2, ZINC	1
10	NB9545 NUT, SPIN LOCK, 1/4-20	1
11	NB8130 CLAMP, 3/4" ID, RETAINER	1
12	MP044800 ADAPTER, CONVERSION, BSPT/NPT, 1/8 X 1/8	1
13	MP019200 SWITCH, OIL PRESSURE, DOUBLE-POLE	1
14	MP8310 VELCRO, HOOK, STUDS	4
15	MP035200 FILTER, RECOIL, KAWASAKI	1
16	MP015200 PLUG, OXYGEN SENSOR	1
17	NB2460 HOSE, VACUUM, 5/32	26"
18	NB2470 FUEL, LINE, 3/8"	26"
19	NB065000 BOLT, HEX, M8 x16, GD 8.8, ZINC	1
20	KA461DA0800 WASHER, LOCK, 8MM	4
21	KA922107027 NUT, HEX, M8	4
22	NB7282 CLAMP, HOSE, NO.38	1
23	MP367200 VALVE, DRAIN, OIL, 3/8" NPT	1
24	MP367700 PULLEY, 4.00", w/ 1.00" BORE	1
25	MP7802 KEY, 1/4 X 1 1/2"	1
26	NB6111 WASHER, LOCK, 5/16"	1
27	NB9267 WASHER, FLAT, 5/16"	1

Deck Sub-Assembly

082510

081610

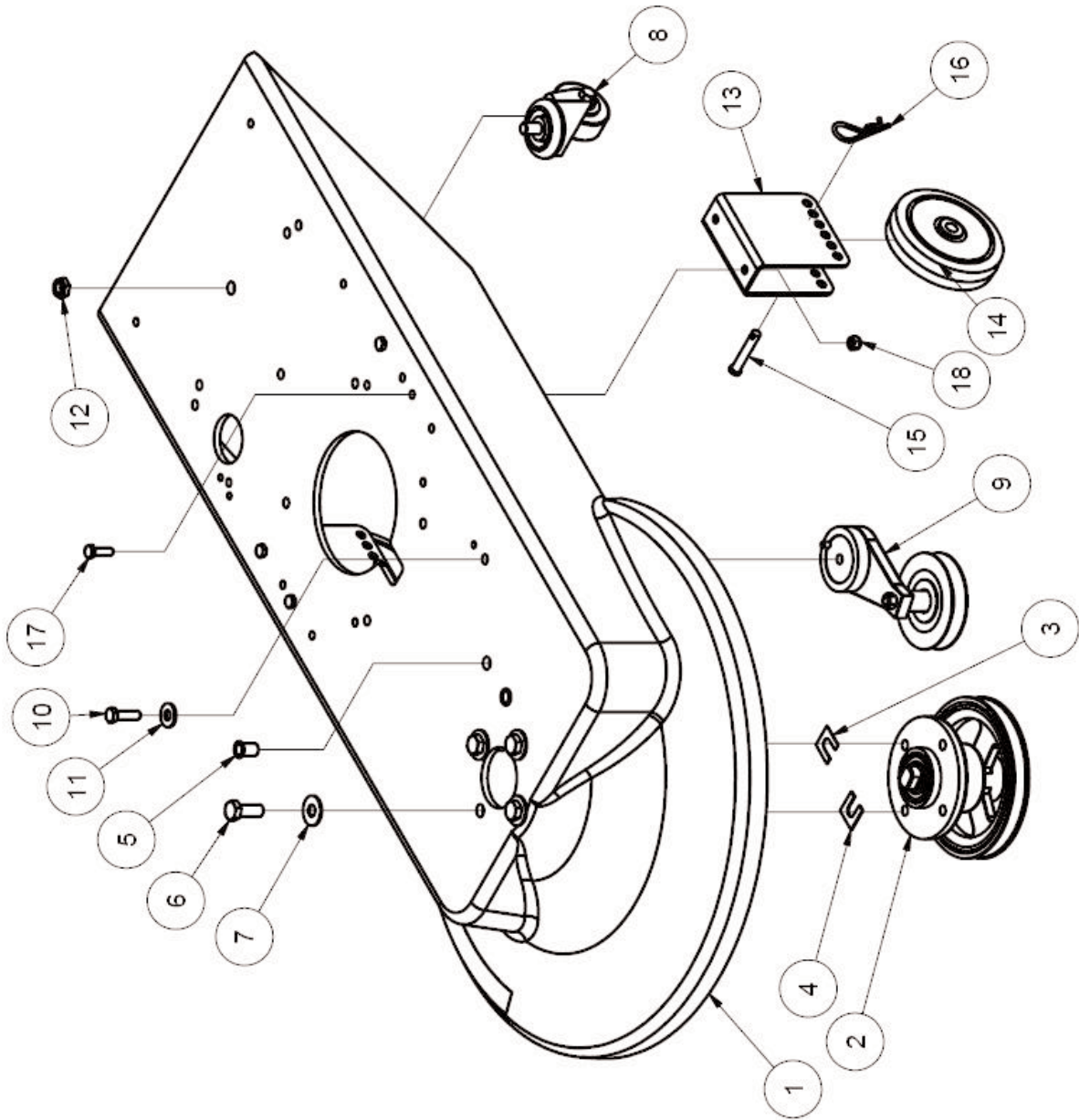

RF032400

Deck Sub-Assembly

Parts List 21"

Ref. Part #	Description	Qty.
1	MP365500 DECK, 21", BASE MDL, DETAILED	1
2	MP107700 SPINDLE, W/6.75" PULLEY, ASM.	1
3	MP197100 SHIM, CAMBER, 1/32"	1
4	MP197000 SHIM, CAMBER, 1/16"	1
5	NB011600 INSERT, 5/16-18, COMPRESSION TYPE	2
6	NB6864 BOLT, HEX, 1/2" X 1 1/4", NC	4
7	NB9269 WASHER, FLAT, 7/16	4
8	MP012801 CASTER, 2 1/2", REAR, 3/4" STEM	1
9	MP071800 TENSIONER, BELT, W/4" PULLEY	1
10	NB6044 SCREW, CAP, 3/8 X 1 1/4	1
11	NB3450 WASHER, FLAT, 3/8"	1
12	NB003100 NUT, HEX, 1/2"-13, JAM	1
13	MP366001 WHEEL BRACKET, ONE PIECE	2
14	MP105300 WHEEL, 5", PERFORMA, FLAT TREAD, GREY	2
15	MP038100 PIN, CLEVIS, 3/8" X 2-1/8"	2
16	LX2105 CLIP, HITCH PIN, STRAIN RELIEF	2
17	NB6545 SCREW, CAP, HH, 5/16"-18 X 1"	4
18	NB3265 NUT, LOCK, 5/16"-18, NC	4

Parts List 28"

Ref. Part #	Description	Qty.
1	MP365800 DECK, 28", BASE MDL, DETAILED	1
2	MP7240 SPINDLE, W/8.75" PULLEY, ASM.	1
3	MP197100 SHIM, CAMBER, 1/32"	1
4	MP197000 SHIM, CAMBER, 1/16"	1
5	NB011600 INSERT, 5/16-18, COMPRESSION TYPE	2
6	NB6864 BOLT, HEX, 1/2" X 1 1/4", NC	4
7	NB9269 WASHER, FLAT, 7/16	4
8	MP012801 CASTER, 2 1/2", REAR, 3/4" STEM	1
9	MP071800 TENSIONER, BELT, W/4" PULLEY	1
10	NB6044 SCREW, CAP, 3/8 X 1 1/4	1
11	NB3450 WASHER, FLAT, 3/8"	1
12	NB003100 NUT, HEX, 1/2"-13, JAM	1
13	MP366001 WHEEL BRACKET, ONE PIECE	2
14	MP105300 WHEEL, 5", PERFORMA, FLAT TREAD, GREY	2
15	MP038100 PIN, CLEVIS, 3/8" X 2-1/8"	2
16	LX2105 CLIP, HITCH PIN, STRAIN RELIEF	2
17	NB6545 SCREW, CAP, HH, 5/16"-18 X 1"	4
18	NB3265 NUT, LOCK, 5/16"-18, NC	4

Handle Sub-Assembly

082510

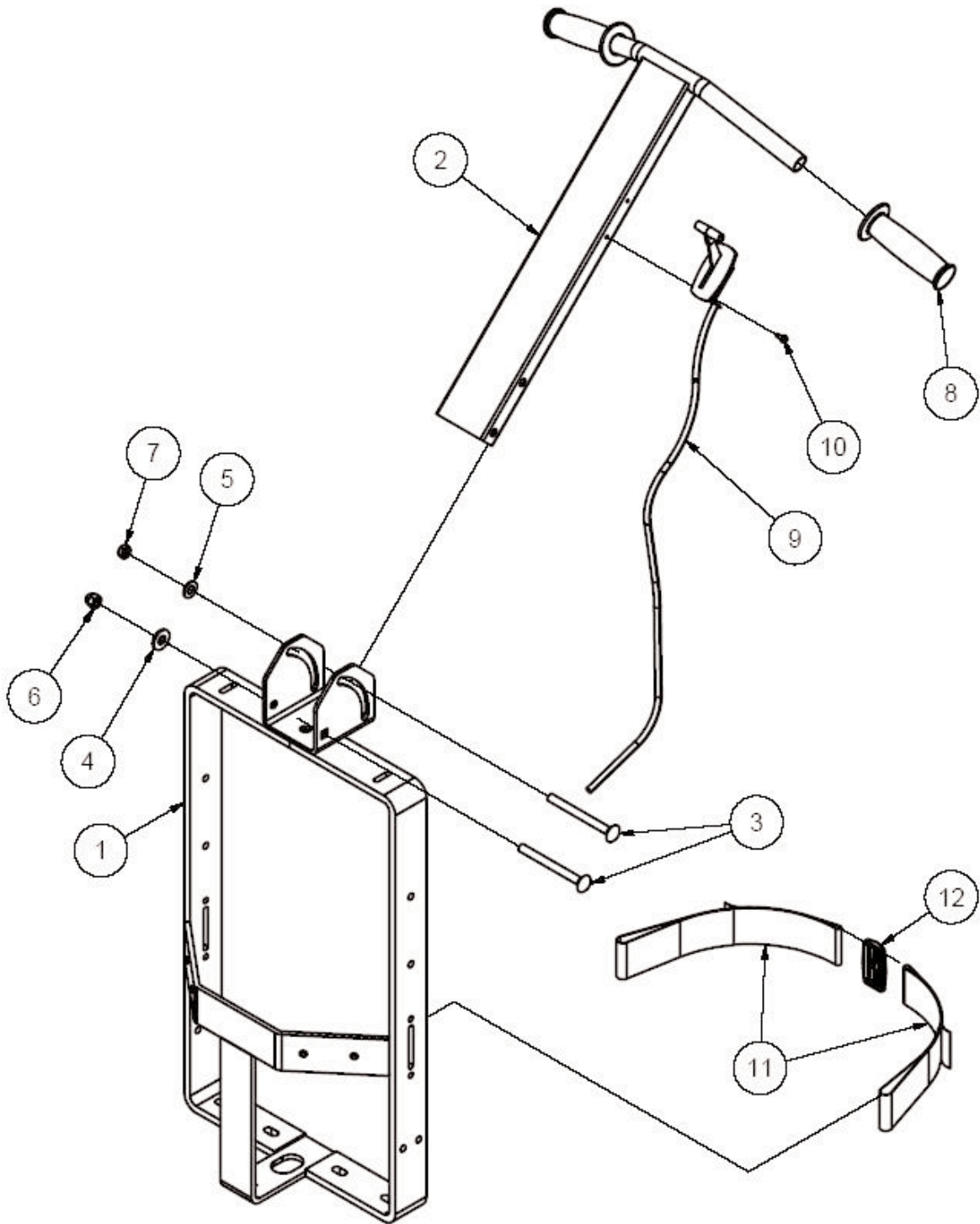

RF032500

081610

Handle Sub-Assembly Continued

Ref. Part #	Description	Qty.
1 MP366500	HANDLE, BASE, WELDMENT	1
2 MP366800	HANDLE, TOP, BASE MDL., WELDMENT	1
3 NB9460	BOLT, CARRIAGE, 3/8-16 X 4, ZINC	2
4 NB3450	WASHER, FLAT, 3/8"	1
5 MX1080	WASHER, FLAT, 3/8"	1
6 NB9470	NUT, ACORN, 3/8-16 UNC	1
7 NB9310	NUT, LOCK, JAM, 3/8-16	1
8 MP366900	GRIP, HANDLE, 7/8", BLK	2
9 MP368000	CABLE, THROTTLE, 46"	1
10 NB4382	SCREW, DRILL KWIK, 8 x 1/2	2
11 MP368100	STRAP, 2" x 23", OPEN ENDS	2
12 MP367600	SLIDE, STRAP, 2", BLK	1

Main Assembly

021711

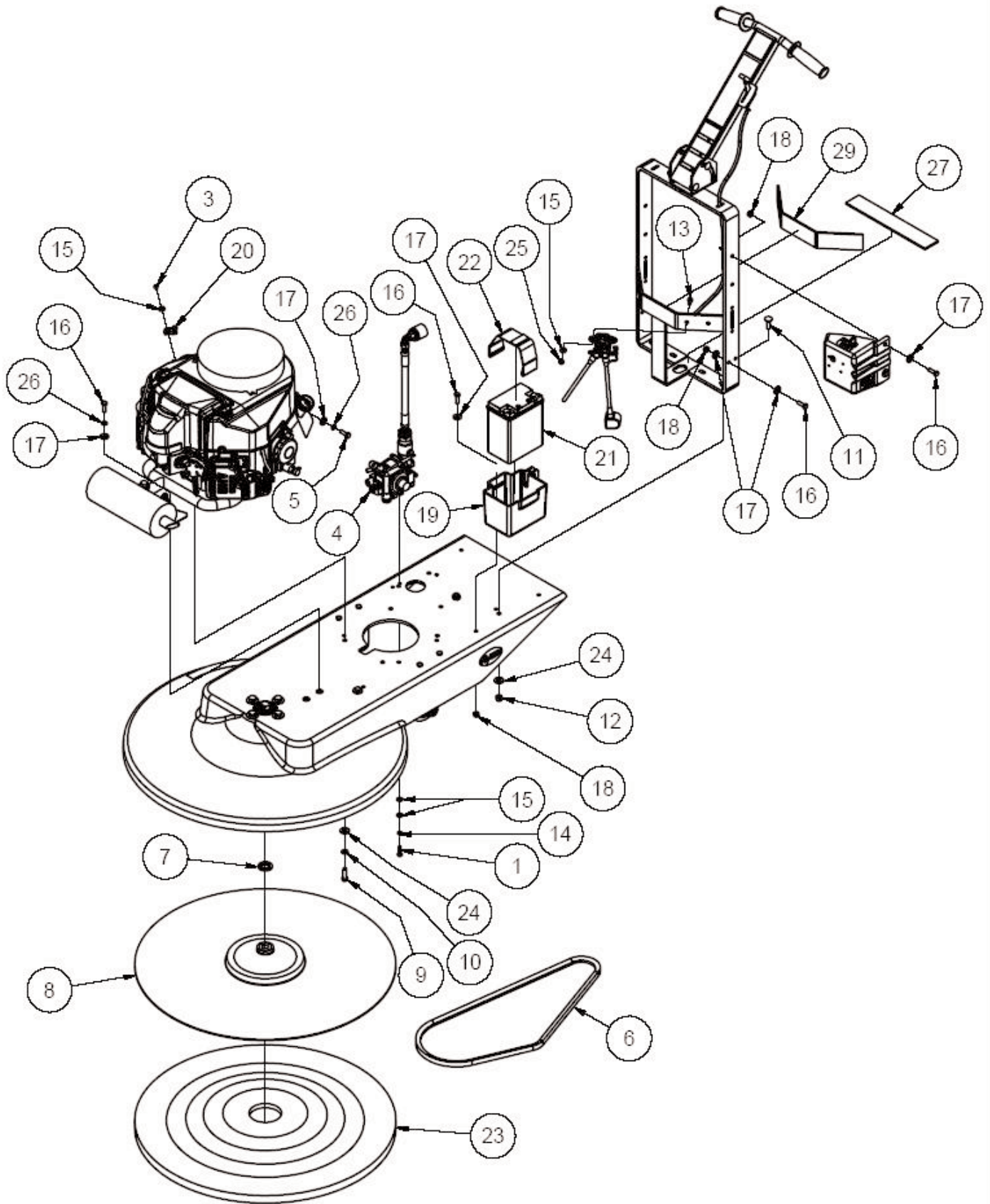

RF032800

021511

Main Assembly Continued

Ref. Part #	Description	Qty.
1 NB6530	SCREW, CAP, HH, 1/4-20 X 1	2
2 MP105900	CYLINDER, STEEL, PAINTED (NOT SHOWN)	1
3 NB064900	SCREW, #10 x 1/2", TRUSS HD, PHIL..	1
4 MP368200	REGULATOR, BASE MDL, ASM.	1
5 NB065100	BOLT, HEX, M8 x 25, GD 8.8, ZINC	1
6A MP041000	BELT, BX-56 (FOR 28" MACHINE)	1
6B MP8070	BELT, BX-46 (FOR 21" MACHINE)	1
7 MP195300	SPACER, BEARING, RIGHT	1
8A MP183700	PADHOLDER, 28", MALISH, W/RISER, ASM.	1
8B MP269400	PADHOLDER, 21", MALISH W/RISER RH THREAD	1
9 NB6044	SCREW, CAP, 3/8 X 1 1/4	4
10 MX1075	WASHER, LOCK, 3/8"	4
11 NB5520	BOLT, CARRIAGE, 3/8"-16 X 1 1/4"	3
12 NB3267	NUT, LOCK, 3/8", NC	3
13 NB019100	BOLT, HEX, 1/4-20 X 3/4, GD5	4
14 NB6110	WASHER, LOCK, 1/4"	2
15 NB3350	WASHER, FLAT, 1/4"	2
16 NB6545	SCREW, CAP, HH, 5/16"-18 X 1"	5
17 NB9267	WASHER, FLAT, 5/16"	7
18 NB3265	NUT, LOCK, 5/16"-18, NC	4
19 MP367500	TRAY, BATTERY, 5-1/4 X 3-1/2	1
20 NB8125	CLAMP, 1/4" ID, RETAINER	1
21 MP362200	BATTERY, 12V, 210CCA, AGM	1
22 MP368100	STRAP, 2" x 23", OPEN ENDS	1
23A PDBB06028	PAD, 28" BLUE BLEND	1
23B PDBB06021	PAD, 21", BLUE BLEND	1
24 NB3450	WASHER, FLAT, 3/8"	7
25 NB3275	NUT, LOCK, 1/4	2
26 NB6111	WASHER, LOCK, 5/16"	3
27 MP6600	VELCRO, FELT, BLACK	12"
28 MP6600	VELCRO, FELT, BLACK	15"

Regulator and Solenoid Assembly

021711

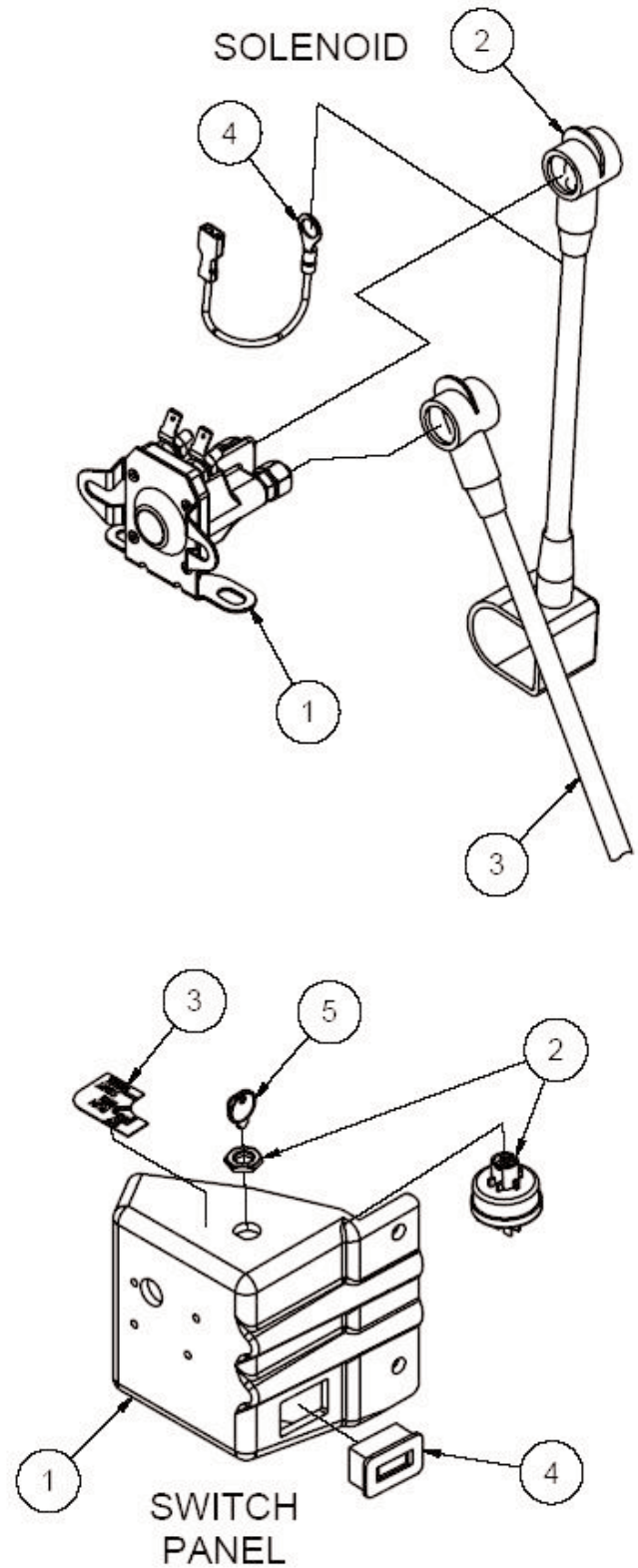
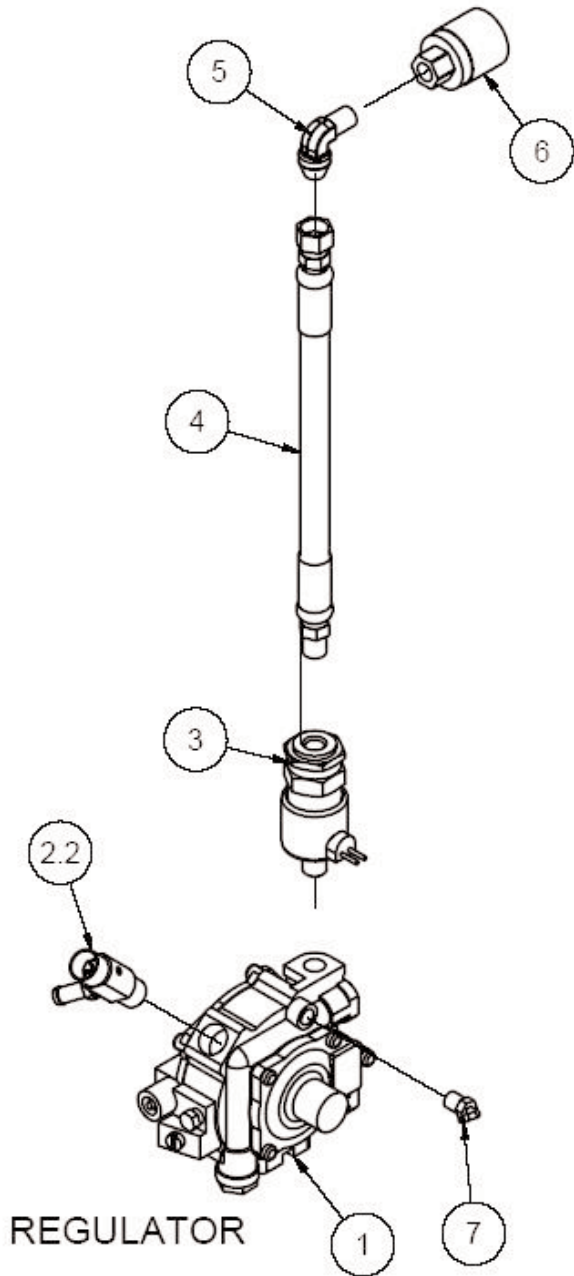

RF032900

020111

**Regulator and Solenoid Assembly
Continued**

Regulator

Ref. Part #	Description	Qty.
1 MP245100	REGULATOR, BEAM, T60	1
2 MP017900	FUEL, ADJUSTMENT, ASSEMBLY	1
3 MP317500	FUELOCK, 12 VOLT, ASM.	1
4 MP367300	HOSE, FUEL, LP, 12", ASM.	1
5 MP4330	FITTING, 49 X 6, REG TO FUELOCK	1
6 MP4500	COUPLER, QUICK REGO, FEMALE	1
7 MP355200	FITTING, ELBOW, NYLON, 1/8 MNPT X 1/8 HB	1

Solenoid

Ref. Part #	Description	Qty.
1 MP367100	SOLENOID, STARTER, 12VDC	1
2 MP366700	CABLE, BATTERY, POS., 9"	1
3 MP120900	CABLE, BATTERY, POSITIVE, 14"	1
4 MP354900	WIRE, SOLENOID, BATTERY	1

Switch Panel

Ref. Part #	Description	Qty.
1 MP367400	PANEL, SWITCH, STARTER, PLASTIC	1
2 MP199000	KEYSWITCH, BURNISHER, RIDE-ON	1
3 SS900001	LABEL, STARTER SWITCH, TRI-LINGUAL	1
4 MP280400	METER, HOUR/TACH, PANEL MOUNT	1
5 KC4834001	KEY, STARTER SWITCH	1

Small Off-Road Engine Certification Warranty Form

Emission Control Warranty Statement

Your Warranty Rights and Obligations

The California Air Resources Board and Amano Pioneer Eclipse Corporation is pleased to explain the emissions control system's warranty on your 2011 small off-road engine. In California, new equipment that use small off-road engines must be designed, built, and equipped to meet the State's stringent anti-smog standards. Amano Pioneer Eclipse Corporation must warrant the emissions control system on your small off-road engine for the period listed below provided there has been no abuse, neglect or improper maintenance of your equipment. Your emissions control system may include parts such as: carburetor's or fuel injection system, ignition system, catalytic converters, fuel tanks, valves, filters, clamps, connectors, and other associated components. Also, included may be hoses, belts, connectors, sensors, and other emission-related assemblies.

Where a warrantable condition exists, Amano Pioneer Eclipse Corporation will repair your small off-road engine at no cost to you including diagnosis, parts and labor.

Manufacturer's Warranty Coverage

This emissions control system is warranted for two years. If any emissions-related part on your equipment is defective, the part will be repaired or replaced by Amano Pioneer Eclipse Corporation.

Owner's Warranty Responsibilities

(a) As the small off-road engine owner, you are responsible for performance of the required maintenance listed in your owner's manual. Amano Pioneer Eclipse Corporation recommends that you retain all receipts covering maintenance on your small off-road engine, but Amano Pioneer Eclipse Corporation cannot deny warranty solely for the lack of receipts or your failure to ensure the performance of all scheduled maintenance.

(b) As the small off-road engine owner, you should however be aware that Amano Pioneer Eclipse Corporation may deny you warranty coverage if your small off-road engine or a part has failed due to abuse, neglect, or improper maintenance or unapproved modifications.

(c) You are responsible for presenting your small off-road engine to an Amano Pioneer Eclipse Corporation distribution center or service center as soon as the problem exists. The warranty repairs should be completed in a reasonable amount of time, not to exceed 30 days. If you have a question regarding your warranty coverage, you should contact Amano Pioneer Eclipse Corporation at 1-800-367-3550.

Defects Warranty Requirements

(a) The warranty period begins on the date the engine or equipment is delivered to an ultimate purchaser.

(b) **General Emissions Warranty Coverage.** Amano Pioneer Eclipse Corporation as the manufacturer of each small off-road engine or equipment must warrant to the ultimate purchaser and each subsequent owner that the engine or equipment is:

- (1) Designed, built, and equipped so as to conform with all applicable regulations adopted by the Air Resources Board; and
- (2) Free from defects in materials and workmanship that causes the failure of a warranted part for a period of two years.

(c) The warranty on emissions-related parts will be interpreted as follows:

- (1) Any warranted part that is not scheduled for replacement as required maintenance in the written instructions required by subsection (d) must be warranted for the warranty period defined in Subsection (b)(2). If any such part fails during the period of warranty coverage, it must be repaired or replaced by the manufacturer according to Subsection (4) below. Any such part repaired or replaced under the warranty must be warranted for the remaining warranty period.
- (2) Any warranted part that is scheduled only for regular inspection in the written instructions required by subsection (d) must be warranted for the warranty period defined in Subsection (b)(2). A

statement in such written instructions to the effect of "repair or replace as necessary" will not reduce the period of warranty coverage. Any such part repaired or replaced under warranty must be warranted for the remaining warranty period.

- (3) Any warranted part that is scheduled for replacement as replacement as required maintenance in the written instructions required by subsection (d) must be warranted for the period of time prior to the first scheduled replacement point for that part. If the part fails prior to the first scheduled replacement, the part must be repaired or replaced by the engine manufacturer according to Subsection (4) below. Any such part repaired or replaced under warranty must be warranted for the remainder of the period prior to the first scheduled replacement point for the part.
- (4) Repair or replacement of any warranted part under the warranty must be performed at no charge to the owner at a warranty station.
- (5) Notwithstanding the provisions of Subsection (4) above, warranty services or Repairs must be provided at all manufacturer distribution centers that are franchised to service the subject engines.
- (6) The owner must not be charged for diagnostic labor that leads to the Determination that a warranted part is in fact defective, provided that such diagnostic work is performed at a warranty station.
- (7) The manufacturer is liable for damages to other engine components Proximately caused by a failure under warranty of any warranted part.
- (8) Throughout the emissions warranty period defined in Subsection (b)(2), the manufacturer must maintain a supply of warranted parts sufficient to meet the expected demand for such parts.
- (9) Any replacement part may be used in the performance of any warranty Maintenance or repairs and must be provided without charge to the owner. Such use will not reduce the warranty obligations of the manufacturer.
- (10) Add-on or modified parts that are not exempted by the Air Resources Board may not be used. The use of any non-exempted add-on or modified parts will be grounds for disallowing a warranty claim. The manufacturer will not be liable to warrant failures of warranted parts caused by the use of a non-exempted add-on or modified part.
- (11) The manufacturer issuing the warranty shall provide any documents that describe that manufacturer's warranty procedures or policies within five working days of request by the Air Resources Board.

(d) Emission Warranty Parts List

- (1) Fuel Metering System
 - (i) Carburetor and internal parts and pressure regulator.
 - (ii) Cold start enrichment system.
- (2) Air Induction System
 - (i) Intake manifold.
 - (ii) Air filter.
- (3) Ignition System
 - (i) Spark Plugs.
 - (ii) Magneto or electronic ignition system.
 - (iii) Spark advance/retard system.
- (4) Exhaust System
 - (iii) Exhaust manifold.
- (5) Miscellaneous Items Used in Above Systems
 - (i) Electronic Fuel Cut-off control.
 - (ii) Vacuum, temperature, and time sensitive valves and switches.
 - (iii) Hoses, belts, connectors, and assemblies.

Amano Pioneer Eclipse Corporation will furnish with each new engine written instructions for the maintenance and use of the engine by the owner.

Exception: This warranty does not apply to any machine models that do not have a catalyst muffler.

Limited Warranty

PE400BU Burnisher

To Qualify for this warranty:

- 1) Machine must be registered at the time of purchase on a form provided by Amano Pioneer Eclipse® Corporation. Your Amano Pioneer Eclipse Distributor is responsible for the registration of your machine. Please cooperate with your Distributor in supplying necessary information on the card.
- 2) The machine must have been purchased from Amano Pioneer Eclipse or an authorized Amano Pioneer Eclipse Distributor.
- 3) This warranty extends to the original purchaser only and is not transferable to subsequent owners.

TIME PERIODS

- 1) Propane Engine warranted by engine manufacturer for (2) years.
- 2) Batteries warranted by battery manufacturer for (1) year.
- 3) Valve train warranted by Amano Pioneer Eclipse for (1) year.
- 4) NINETY (90) DAY WARRANTY - For the model PE400BU. Warranted to be free from defects in material and workmanship for a period of ninety (90) days from the date of purchase by the original owners. (See Exclusions.)

EXCLUSIONS (Not Covered by Warranty)

- 1) Parts that fail through normal wear by reason of their characteristics (cords, pads, belts, wheels, or other consumable parts).
- 2) This warranty does not extend to parts affected by misuse, neglect, abuse or improper maintenance. All defective parts must be returned to the Distributor for credit.

THE OBLIGATION OF AMANO PIONEER ECLIPSE CORPORATION

- 1) The obligation of Amano Pioneer Eclipse under this warranty is limited to repairing or replacing, at its option, any part which is proven to be defective in material or workmanship under normal use for the applicable period stated above.
- 2) Warranty repairs will be made by your Amano Pioneer Eclipse Distributor without charge for parts and labor. They will be compensated with a warranty labor rate of \$45.00 per hour.
- 3) Parts repaired or replaced under this warranty are warranted only during the balance of the original warranty period. All defective parts replaced under these warranties become the property of Amano Pioneer Eclipse.

WARRANTY SERVICE

To obtain warranty service, take your machine and proof of purchase to any authorized Amano Pioneer Eclipse Distributor. Amano Pioneer Eclipse will not reimburse expenses for service calls or travel. For the Distributor in your area, call Amano Pioneer Eclipse Customer Service Department at 800-367-3550 or 1-336-372-8080. If you are dissatisfied with the service that you receive, call or write Amano Pioneer Eclipse Customer Service Department for further assistance.

INSTRUCTIONS AND CONDITIONS FOR WARRANTY REIMBURSEMENT

- Order replacement part: Orders will be processed and charged, as normal procedure.
- Call APEC for R/A number.
- You will need the Engine Serial Number, Machine Serial Number, and the Machine Model Number.
- Parts must be returned, accompanied with the R/A number to be eligible for warranty credit.
- All Warranty Parts will be shipped prepaid UPS Ground, any other method will be at the recipients expense.
- Freight on any Warranty Part after 30 days must be paid for by the Purchaser.
- Warranty labor rate is 45.00 per hour.
- Credit will be issued upon completion of the above steps, at above rates.

DISCLAIMER OF CONSEQUENTIAL

AMANO PIONEER ECLIPSE DISCLAIMS ANY RESPONSIBILITY FOR LOSS OF USER TIME OF THE AMANO PIONEER ECLIPSE MACHINE OR ANY OTHER INCIDENTAL OR CONSEQUENTIAL DAMAGE EXCEPT AS STATED IN THE WARRANTY APPLICABLE TO EACH MACHINE. EXCEPT AS STATED IN SUCH WARRANTIES, THE COMPANY DOES NOT OTHERWISE WARRANT ANY MACHINE AND NO WARRANTY, EXPRESS, IMPLIED OR STATUTORY IS MADE BY THE COMPANY.

Copyright 2011 Amano Pioneer Eclipse Corporation



SAFETY AWARENESS FORM FOR PROPANE BURNISHERS

The following must be completed before an employee may use a propane burnisher!

I have read the "Operators Manual" and understand it.

Name: _____ Date: _____
(Print or Type)

Demonstrate to your instructor that you can do the following properly and safely:

How to prepare the propane burnisher for operation:

- A. Install Pads.....
- B. Check Oil.....
- C. Adjust Handle.....
- D. Check fuel cylinder for overfilling.....
- E. Install fuel cylinder.....
- F. Do you have a MSDS for propane?.....

How to operate a propane burnisher:

- A. Start and stop the engine.....
- B. Emergency stop.....
- C. Clean air filter.....

Cautions:

- A. Allow only qualified, trained personnel to operate the machine.
- B. Use only D.O.T. approved fuel cylinders supplied by Amano Pioneer Eclipse.
- C. Always store fuel cylinders outside in a proper enclosure.
- D. Never vent a fuel cylinder inside.
- E. Always wear a CO detector badge.
- F. Never leave the machine running unattended.
- G. Know what to do and whom to call in case of emergency.

When all items are checked off and this form is signed by an instructor or supervisor, you may operate a propane burnisher.

Employee Signature

Date

Instructor/Supervisor Signature

Date



Amano Pioneer Eclipse Corporation

1 Eclipse Rd • PO Box 909
Sparta, North Carolina 28675 • USA
www.pioneer-eclipse.com

+1-336-372-8080
1-800-367-3550
Fax 1-336-372-2913