

SkyAzúl

EQUIPMENT SOLUTIONS

DS-160



SERVICE MANUAL

NOTICE

SkyAzúl makes no warranty of any kind with regard to this material, including, but not limited to, the implied warranties of merchantability and/or its fitness for a particular purpose.

SkyAzúl will not be liable for errors contained in this manual or for incidental or consequential damages in connection with the furnishing, performance, or use of this manual. This document contains proprietary information, which is protected by copyright, and all rights are reserved.

No part of this document may be photocopied, reproduced, or translated to another language without the prior written consent of SkyAzúl.

SkyAzúl reserves proprietary rights to all drawings, photos and the data contained therein. The drawings, photos and data are confidential and cannot be used or reproduced without the written consent of SkyAzúl. The drawings and/or photos are subject to technical modification without prior notice.

All information in this document is subject to change without notice.



SkyAzúl, Inc.
200 W. Main Street, Suite, 2A
Middletown, MD 21769
Fax 301-371-0029
info@skyazul.com

TABLE OF CONTENTS

| | | |
|--------|--|----|
| 1 | GENERAL INFORMATION | 1 |
| 2 | WARNINGS | 1 |
| 3 | SYSTEM DESCRIPTION | 2 |
| 4 | GENERAL TROUBLESHOOTING INFORMATION | 3 |
| 4.1 | GENERAL FLOW CHARTS | 3 |
| 5 | ERROR CODES | 4 |
| 5.1 | OPERATING ERRORS E01 THROUGH E05 | 4 |
| 5.2 | LOCKOUT FUNCTION ERRORS 07 AND 08 | 5 |
| 5.3 | ANALOG INPUT CHANNEL ERRORS | 5 |
| 5.3.1 | TRUBLESHOOTING A SENSOR PROBLEM USING THE DISPLAY | 5 |
| 5.3.2 | ERROR CODES FOR THE ANALOG INPUTS | 6 |
| 5.4 | ERRORS 31 AND UP | 8 |
| 6 | FUNCTION LOCKOUT | 11 |
| 7 | NO DISPLAY | 12 |
| 8 | ANTI-TWO BLOCK PROBLEM | 14 |
| 9 | LENGTH READING PROBLEM | 17 |
| 10 | ANGLE READING PROBLEM | 19 |
| 11 | LOAD READING PROBLEM | 21 |
| 12 | DATA TRANSFER CENTRAL UNIT <--> CONSOLE | 23 |
| 13 | DRAWINGS | 25 |
| 13.1 | SYSTEM WIRING DIAGRAM | 25 |
| 13.2 | SYSTEM WIRING DIAGRAM | 26 |
| 13.3 | SYSTEM WIRING DIAGRAM | 27 |
| 13.4 | CENTRAL UNIT MAIN BOARD TERMINATION AND BREAKDOWN / PARTS LIST | 28 |
| 13.5 | CENTRAL UNIT MAIN BOARD LAYOUT | 29 |
| 13.6 | CONSOLE DS160/0005 / PARTS LIST | 30 |
| 13.7 | PRESSURE TRANSDUCER (DAVS314) | 31 |
| 13.8 | PRESSURE TRANSDUCER (DAVS300 / 3401) | 31 |
| 13.9 | CABLE REEL | 32 |
| 14 | PROCEDURES | 33 |
| 14.1 | EPROM LOCATION AND INSTALLATION PROCEDURE | 33 |
| 14.2 | MAIN BOARD REPLACEMENT PROCEDURE | 34 |
| 14.3 | CALIBRATION OF SENSORS PROCEDURE | 35 |
| 14.3.1 | PRESSURE TRANSDUCER CALIBRATION PROCEDURE | 35 |
| 14.3.2 | LENGTH SENSOR CALIBRATION PROCEDURE | 36 |
| 14.3.3 | ANGLE SENSOR CALIBRATION PROCEDURE | 37 |
| 14.4 | CABLE REEL LWG308/0001 ADJUSTMENT PROCEDURE | 38 |
| 14.5 | CABLE REEL LENGTH CABLE REPLACEMENT PROCEDURE | 39 |
| 15 | TROUBLESHOOTING MOISTURE | 40 |
| 15.1.1 | WATER INGRESS | 40 |
| 15.1.2 | CONDENSATION | 41 |
| 16 | SENSOR THEORY | 42 |
| 16.1 | THEORY 1. OPERATION OF PISTON SIDE LOAD SENSOR | 42 |
| 16.2 | THEORY 2. OPERATION OF ROD SIDE LOAD SENSOR | 43 |
| 16.3 | THEORY 3. OPERATION OF BOOM LENGTH SENSOR | 44 |

| | |
|--|----|
| 16.4 THEORY 4. OPERATION OF ANGLE SENSOR..... | 45 |
| 17 DS50C TO DS160 UPGRADE INSTALLATION | 46 |
| 17.1 CONSOLE MOUNTING..... | 47 |
| 17.2 CENTRAL UNIT MOUNTING | 47 |
| 17.3 SOFTWARE..... | 47 |
| 17.4 PRESSURE TRANSDUCER REPLACEMENT | 47 |
| 17.5 DS160 COMPONENT INSTALLATION PROCEDURE..... | 48 |
| 17.6 LMI SYSTEM TEST PROCEDURE..... | 55 |

1 GENERAL INFORMATION

The PAT Load Moment Indicator (LMI) DS 160 has been designed to provide the crane operator with the essential information required to operate the machine within its design parameters.

Using different sensing devices, the Load Moment Indicator monitors various crane functions and provides the operator with a continuous reading of the crane's capacity. The readings continuously change as the crane moves through the motions needed to make the lift.

The LMI provides the operator with information regarding the angle of the boom, working radius, rated load and the total calculated weight being lifted by the crane.

If non permitted conditions are approached, the DS 160 Load Moment Indicator will warn the operator by sounding an audible alarm, lighting a warning light and locking out those functions that may aggravate the crane's condition.

Refer to operator's manual 031-300-190-139 for console operating instructions.

2 WARNINGS

The LMI is an operational aid that warns a crane operator of approaching overload conditions and of over hoist conditions that could cause damage to equipment and personnel.

The device is not, and shall not, be a substitute for good operator judgment, experience and use of accepted safe crane operating procedures.

The responsibility for the safe crane operation shall remain with the crane operator who shall ensure that all warnings and instructions supplied are fully understood and observed.

Prior to operating the crane, the operator must carefully and thoroughly read and understand the information in this manual to ensure that he knows the operation and limitations of indicator and crane.

Proper functioning depends upon proper daily inspection and observance of the operating instructions set forth in this manual. Refer to Section *Pre-Operation Inspection and Calibration Verification* of the operator's manual.



WARNING

The LMI can only work correctly, if all adjustments have been properly set. For correct adjustment, the operator has to answer thoroughly and correctly all questions asked during the setup procedure in accordance with the real rigging state of the crane. To prevent material damage and serious or even fatal accidents, the correct adjustment of the LMI has to be ensured before starting the crane operation.

3 SYSTEM DESCRIPTION

The PAT Load Moment Indicator DS 160 consists of a central microprocessor unit, operating console, length/angle sensor, pressure transducers, and anti-two block switches.

The system operates on the principle of reference/real comparison. The real value, resulting from the load measurement is compared with the reference data, stored in the central processor memory and evaluated in the microprocessor. When limits are reached, an overload warning signal is generated at the operator's console. At the same time, the crane functions, such as hoist up and boom down, will be stopped.

The fixed data regarding the crane, such as capacity charts, boom weights, centers of gravity and dimensions are stored in memory chips in the central processor unit. This data is the reference information used to calculate the operating conditions.

The length/angle sensors inside the cable reel, which is mounted on the boom, measure the boom length and angle. The boom length is measured by the cable reel cable that also serves as an electrical conductor for the anti two-block switches.

The crane load is measured by pressure transducers attached to the piston and rod sides of the hoist cylinders.

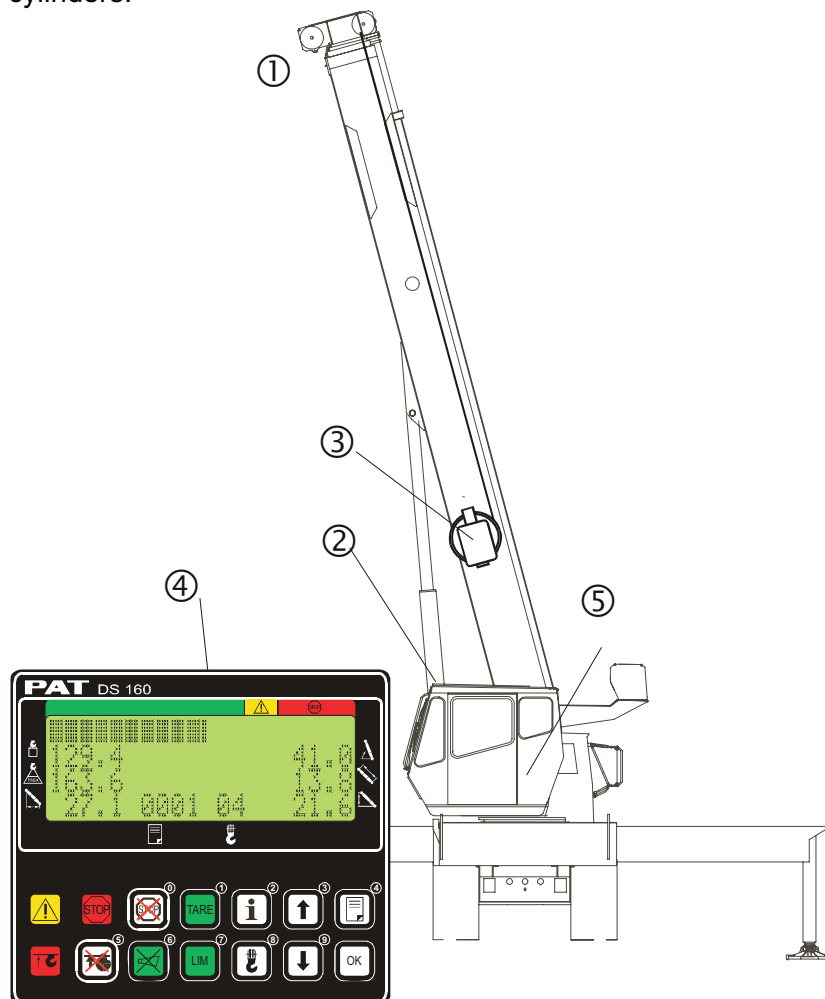

1. A2B Switch(-es)
2. Pressure Transducers
3. Cable Reel
4. Console
5. Central Unit (in cab or outside)

Fig. 1: Components of the LMI System PAT DS 160

4 GENERAL TROUBLESHOOTING INFORMATION

This section explains how to handle a problem that may arise with the PAT DS 160 System. The procedures are given in flowchart format for the following sections. Start with the general flowchart below that will guide you to one of the noted detailed sections. Use the Table of Contents to find the drawings and procedures that are referenced in these sections. **The system wiring diagram and central unit spare parts list are machine specific and can be found in the central unit lid. The system wiring diagram in the central unit lists component part numbers.**

4.1 GENERAL FLOW CHARTS

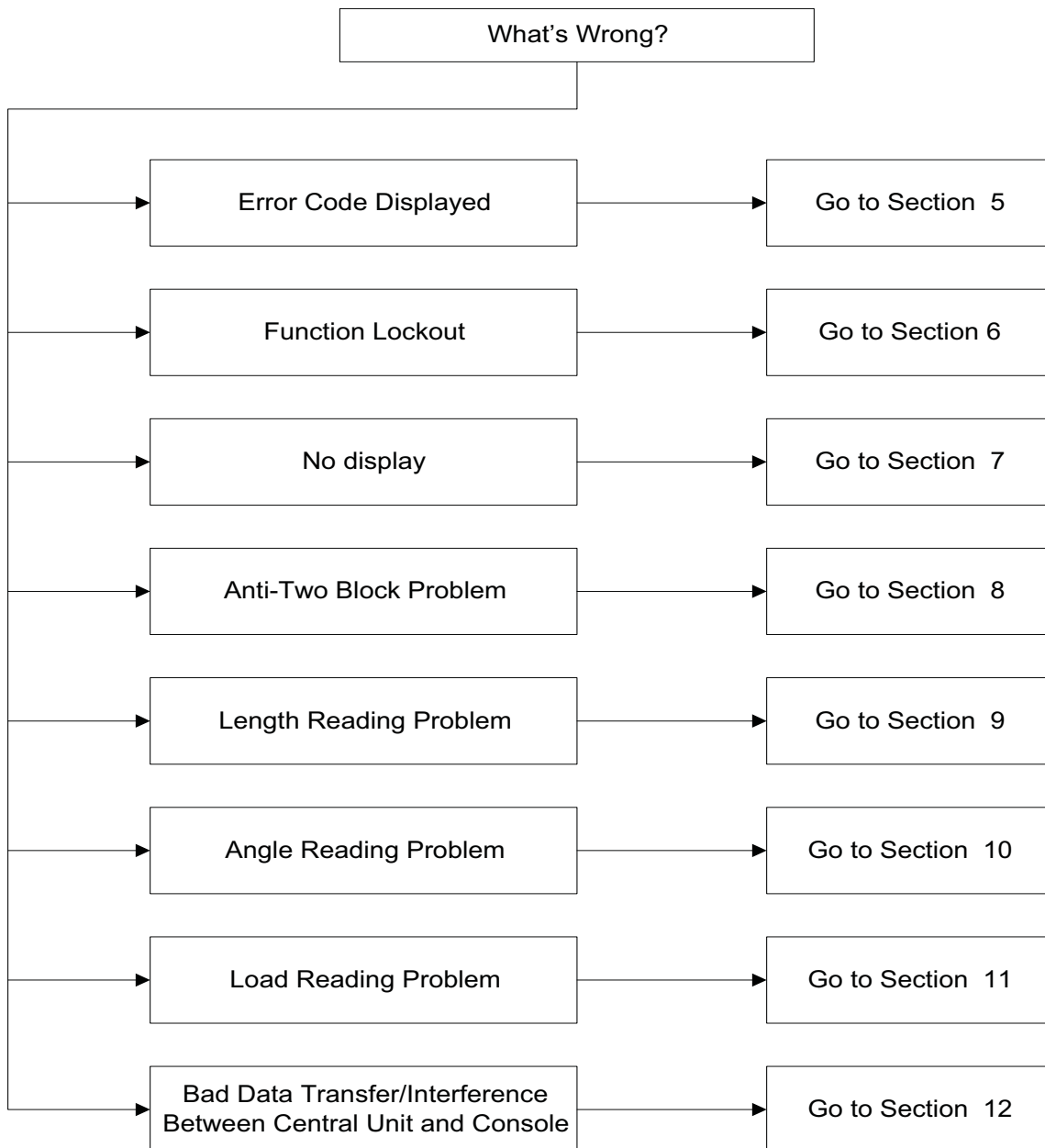

5 ERROR CODES

5.1 Operating Errors E01 through E05

These errors are usually caused by operating in a way that is not allowed per the load charts.

Note: If an error message is displayed which is not contained in the following list, please contact the PAT service department.

| Error Code | Error | Cause | Elimination |
|------------|---|---|---|
| E01 | Fallen below radius range or angle range exceeded | <ul style="list-style-type: none"> Fallen below the minimum radius or gone past the maximum angle specified in the respective load chart due to hoisting up the boom too far | <ul style="list-style-type: none"> Hoist the boom down to a radius or angle specified in the load chart. |
| E02 | Radius range exceeded or fallen below angle range | <ul style="list-style-type: none"> Gone past the maximum radius or fallen below the minimum angle specified in the respective load chart due to hoisting down the boom too far | <ul style="list-style-type: none"> Hoist the boom up to a radius or angle specified in the load chart. |
| E04 | Operating mode not existing or non permitted slewing zone | <ul style="list-style-type: none"> A non existing operating mode has been selected The selected operating mode is not available in the data EPROM or blocked. The boom is in a non-permitted slewing zone | <ul style="list-style-type: none"> Set the correct operating mode for the crane configuration in question Check programming of the data EPROM Slew the crane into a permitted area. |
| E05 | Forbidden length range of the main boom | <ul style="list-style-type: none"> Boom has been extended too far or not enough, e.g. the boom length has been moved out of the permitted range for load charts. The length sensor adjustment was modified, e.g. cable slid off the length sensor reel. Clutch between length sensor pot and drive is defective Failure of the +5V-supply for the analog part of the LMI-analog board. Length potentiometer defective. | <ul style="list-style-type: none"> Retract or extend boom to the correct length. Retract the boom. Check the pretension on the cable. Open the length sensor and carefully turn the length pot counterclockwise to the detent with a screwdriver. Completely replace the clutch with the drive wheel and adjust length sensor pot Check +5V-voltage. If there is no voltage or break down at a charge of 50 ohm approximately, exchange LMI board. Replace length potentiometer. |

5.2 Lockout Function Errors 07 and 08

These errors are caused by defects around the function lockouts.

| Error Code | Error | Cause | Elimination |
|------------|---|---|--|
| E07 | Faulty acknowledgment of the overload relay on the connection board. The relay should be energized, the 2nd contact however is indicated to be off, or the 2nd contact is indicated to be on while the relay should be de-energized. | <ul style="list-style-type: none"> Overload relay or main board are defective LMI board defective | <ul style="list-style-type: none"> Replace main board |
| E08 | No acknowledgment from the anti-two-block relay | <ul style="list-style-type: none"> refer to E07 | <ul style="list-style-type: none"> refer to E07 |

5.3 Analog Input Channel Errors

These errors occur if the input signal of an analog input channel falls below (E1x) the minimum (500V) or exceeds (E2x) the maximum (4500V) as measured on the troubleshooting display.

The analog channels are as follows (Use theory section to define voltage or current at terminal strip):

| Sensor | Pins Terminal X1 | Lower Limit | Upper Limit |
|-----------------------------------|------------------|-------------|-------------|
| Piston Pressure Transducer | 32 | E12 | E22 |
| Rod Pressure Transducer | 33 | E13 | E23 |
| Length Sensor | 34 | E11 | E21 |
| Angle Sensor | 35 | E15 | E25 |

5.3.1 Troubleshooting a Sensor Problem using the Display

For a sensor error or problem with a sensor, look at the output voltage of the pressure transducer, length, and angle sensors on the display screen and compare the reading with the following:

Pressure transducers (piston and rod), 500mV @ 0psi

Length sensor, 500mV @ retracted boom length

Angle sensor, 4500mV at 0°, 2500mV at 45°, or 500mV at 90°

Note: The sensor output voltages displayed will not be the same as measured in the central unit.

To access the analog output screen use the following procedure.

- From the operating screen, press and hold the information button  for 5 seconds.
- The screen show the following selections:
 - sensor outputs
 - exit
- Use the 'UP' and 'DOWN' arrows to high light (text flashes) sensor outputs, and then press 'OK' to display a similar screen as shown below:
- Press the 'OK' button to exit back to operating screen.

All Analog input voltages (shown in millivolts), received from the sensors will be displayed here as described below. The minimum values are show in the screen pictured.



5.3.2 Error Codes for the Analog Inputs

If it exceeds these limits, the following errors are triggered: (NOTE: the upper limit follows the lower limit error, i.e. 11 and 21, 12 and 22, 13 and 23...)

| Error Code | Error | Cause | Elimination |
|------------|--|---|---|
| E11 | Fallen below limit for the measuring channel "Length telescopic boom". | <ul style="list-style-type: none"> Length sensor potentiometer defective. Electronic board in the measuring channel defective. | <ul style="list-style-type: none"> Replace length sensor potentiometer. Replace LMI board. |
| E21 | Upper limit value for measuring channel "length telescopic boom" exceeded. | <ul style="list-style-type: none"> Length sensor potentiometer defective. Electronic part in the measuring channel defective. | <ul style="list-style-type: none"> Replace length sensor potentiometer. Replace LMI board. |
| E12 | Fallen below the lower limit value in the measuring channel "pressure piston side" | <ul style="list-style-type: none"> Cable between the central unit and pressure transducers defective or water inside the plugs Pressure transducer is defective. Electronic component in the measuring channel is defective. | <ul style="list-style-type: none"> Check cable as well as plugs, replace, if need be. Replace pressure transducer Replace LMI main board or processor board. |
| E22 | Upper limit value in measuring channel "pressure piston side" has been exceeded | <ul style="list-style-type: none"> refer to E12 | <ul style="list-style-type: none"> refer to E12 |

| Error Code | Error | Cause | Elimination |
|-------------------|---|---|--|
| E13 | Fallen below lower limit value in the measuring channel "pressure rod side" | <ul style="list-style-type: none"> • refer to E12 | <ul style="list-style-type: none"> • refer to E12 |
| E23 | Upper limit value in measuring channel "pressure rod side" has been exceeded. | <ul style="list-style-type: none"> • refer to E12 | <ul style="list-style-type: none"> • refer to E12 |
| E15 | Fallen below lower limit value for the measuring channel "angle main boom". | <ul style="list-style-type: none"> • Angle sensor defective. • Electronic part in the measuring channel defective. | <ul style="list-style-type: none"> • Replace angle sensor. • Replace LMI board. |
| E25 | Upper limit value in measuring channel "angle main boom" exceeded | <ul style="list-style-type: none"> • refer to E15 | <ul style="list-style-type: none"> • refer to E15 |
| E16 | Fallen below lower limit value for the measuring channel "middle section". | <ul style="list-style-type: none"> • Angle sensor defective. • Electronic part in the measuring channel defective. | <ul style="list-style-type: none"> • Replace angle sensor. • Replace LMI board. |
| E26 | Upper limit value in measuring channel "middle section" exceeded | <ul style="list-style-type: none"> • refer to E16 | <ul style="list-style-type: none"> • refer to E16 |
| E17 | Fallen below lower limit value for the measuring channel "telescopic jib". | <ul style="list-style-type: none"> • Angle sensor defective. • Electronic part in the measuring channel defective. | <ul style="list-style-type: none"> • Replace angle sensor. • Replace LMI board. |
| E27 | Upper limit value in measuring channel "telescopic jib" exceeded | <ul style="list-style-type: none"> • refer to E17 | <ul style="list-style-type: none"> • refer to E17 |
| E19 | Reference and/or supply voltage defective | <ul style="list-style-type: none"> • The supply voltage is falsified by one of the sensors (DAV, LWG) • Electronic component is defective | <ul style="list-style-type: none"> • Check the voltages on the LMI main board (AGND = MP0). Check sensors, plugs and cable, replace, if need be. • Replace LMI board |

5.4 Errors 31 and up

Miscellaneous Errors, most of them caused by electronics.

| Error Code | Error | Cause | Elimination |
|------------|--|---|---|
| E31 | Error in the system program | <ul style="list-style-type: none"> The system program EPROM is defective. | <ul style="list-style-type: none"> Replace system program PROM (D13) |
| E37 | Error in the program run. | <ul style="list-style-type: none"> EPROM with System program is defective Electronic component on the main board is defective | <ul style="list-style-type: none"> Replace system program EPROM. Replace main board. |
| E38 | System program and data EPROM do not match. | <ul style="list-style-type: none"> The system program in the LMI does not match to the programming in the data EPROM | <ul style="list-style-type: none"> Replace the system program EPROM (D13) or the data EPROM (D1) |
| E41 | Error in the internal write/read memory (RAM) of the computer component 80C537 | <ul style="list-style-type: none"> Computer component 80C537 defective CPU module defective Processor board defective. | <ul style="list-style-type: none"> Replace computer component 80C537. Replace CPU module. Replace processor board with CPU module. |
| E42 | Error in the external write/read memory, 1st part (RAM) | <ul style="list-style-type: none"> Write/read memory (CMOS RAM) or processor board defective. | <ul style="list-style-type: none"> Replace processor board with CPU module. |
| E43 | Error in the external write/read memory, 2nd part (RAM) | <ul style="list-style-type: none"> refer to E42 | <ul style="list-style-type: none"> refer to E42 |
| E48 | Error in the internal write/read memory (RAM) | <ul style="list-style-type: none"> Computer component 80C537 defective Processor board defective. | <ul style="list-style-type: none"> Replace processor board (main board) |
| E51 | Error in the data EPROM or EEPROM. | <ul style="list-style-type: none"> No valid data in the data EEPROM. Memory module wrongly bridged. Crane data EPROM defective | <ul style="list-style-type: none"> Load data EEPROM containing valid data. Bridge memory module acc. to memory type Replace crane data EPROM |
| E52 | Error in load chart PROM. | <ul style="list-style-type: none"> Memory module wrongly bridged. Load chart EPROM defective. | <ul style="list-style-type: none"> Bridge memory module acc. to memory type. Replace load chart EPROM |
| E56 | Error in the data EEPROM. | <ul style="list-style-type: none"> Memory module wrongly bridged. Crane data EEPROM defective | <ul style="list-style-type: none"> Bridge memory module acc. to memory type Replace crane data EEPROM |

| Error Code | Error | Cause | Elimination |
|-------------------|---|--|--|
| E57 | Error in serial crane data EEPROM. | <ul style="list-style-type: none"> Serial crane data EEPROM does not contain valid data. Memory module defective | <ul style="list-style-type: none"> Write data on the serial crane data EEPROM (by means of test program or on-line function), then restart the LMI Replace memory module. |
| E58 | Error in the serial analog data EEPROM. | <ul style="list-style-type: none"> No valid data in the serial analog data EEPROM. LMI module(s) defective. | <ul style="list-style-type: none"> Write data on the serial analog data EEPROM by means of the test program, then, restart the LMI Replace LMI module(s). |
| E82 | No pressure change sensed during boom down or telescope out | <ul style="list-style-type: none"> Blocked velocity fuse No pressure change at piston transducer | <ul style="list-style-type: none"> Verify correct operation of the velocity fuse. |
| E83 | Error in Telecode | <ul style="list-style-type: none"> The selected telecode is not available | <ul style="list-style-type: none"> Select an available telecode |
| E85 | Error in the radius determination | <ul style="list-style-type: none"> The computed radius is too small (negative deflection) | <ul style="list-style-type: none"> Check the programming in the data EPROM. |
| E91 | No data transmission from the console to the central unit | <ul style="list-style-type: none"> +UB supply voltage to the console is interrupted Interruption or accidental ground in the line between console electronics and central unit Transmitter/receiver module is defective | <ul style="list-style-type: none"> Check +UB voltage at terminal X1 of the console electronics Check the connection console electronics - central unit. In case of an accidental ground, the transmitter module of the console electronics might be damaged. Exchange console electronics or LMI main board resp. |
| E92 | Error in the data transmission from console to central unit | <ul style="list-style-type: none"> Loose connection in the line between console electronics and central unit Transmitter/receiver module is defective | <ul style="list-style-type: none"> Check the connection between console electronics and central unit Exchange console electronics or LMI main board resp. |
| E93 | Error in the data transmission from the central unit to the console | <ul style="list-style-type: none"> refer to E92 | <ul style="list-style-type: none"> refer to E92 |

| Error Code | Error | Cause | Elimination |
|-------------------|---|--|--|
| E94 | No data transmission from the central unit to the console | <ul style="list-style-type: none"> • Interruption or accidental ground in the cable between central unit and console • 5 V supply of the computer in the central unit is missing • 5 V supply is too low • Transmitter/receiver module is defective • Computer module is defective • Electro-magnetic interferences (e.g. when switching contactors or valves) | <ul style="list-style-type: none"> • Check wiring to the console (in case of accidental ground, replace console electronics, too). • Check connection to the power unit • Exchange the LMI main board • Replace console electronics or LMI main board • Replace processor board. • Eliminate the source of interferences by inverse diodes or varistors. |
| E95 | Error in the console EPROM | <ul style="list-style-type: none"> • The console EPROM is defective. | <ul style="list-style-type: none"> • Replace the console EPROM |
| E96 | Error in the internal RAM of the console. | <ul style="list-style-type: none"> • The CPU of the console is defective. • The console main board is defective. | <ul style="list-style-type: none"> • Replace the CPU of the console • Replace the console main board. |

6 FUNCTION LOCKOUT

PROBLEM: The lever lockout system of the crane is activated. Crane movements “hoist up”, “boom extended”, and “boom down” are stopped. Only if the crane is not in overload or two-block condition continue with flow chart.

WARNING: If overload or A2B condition exists, use extreme caution and move the crane out of the condition.

If Error Code is displayed goto Section 5.

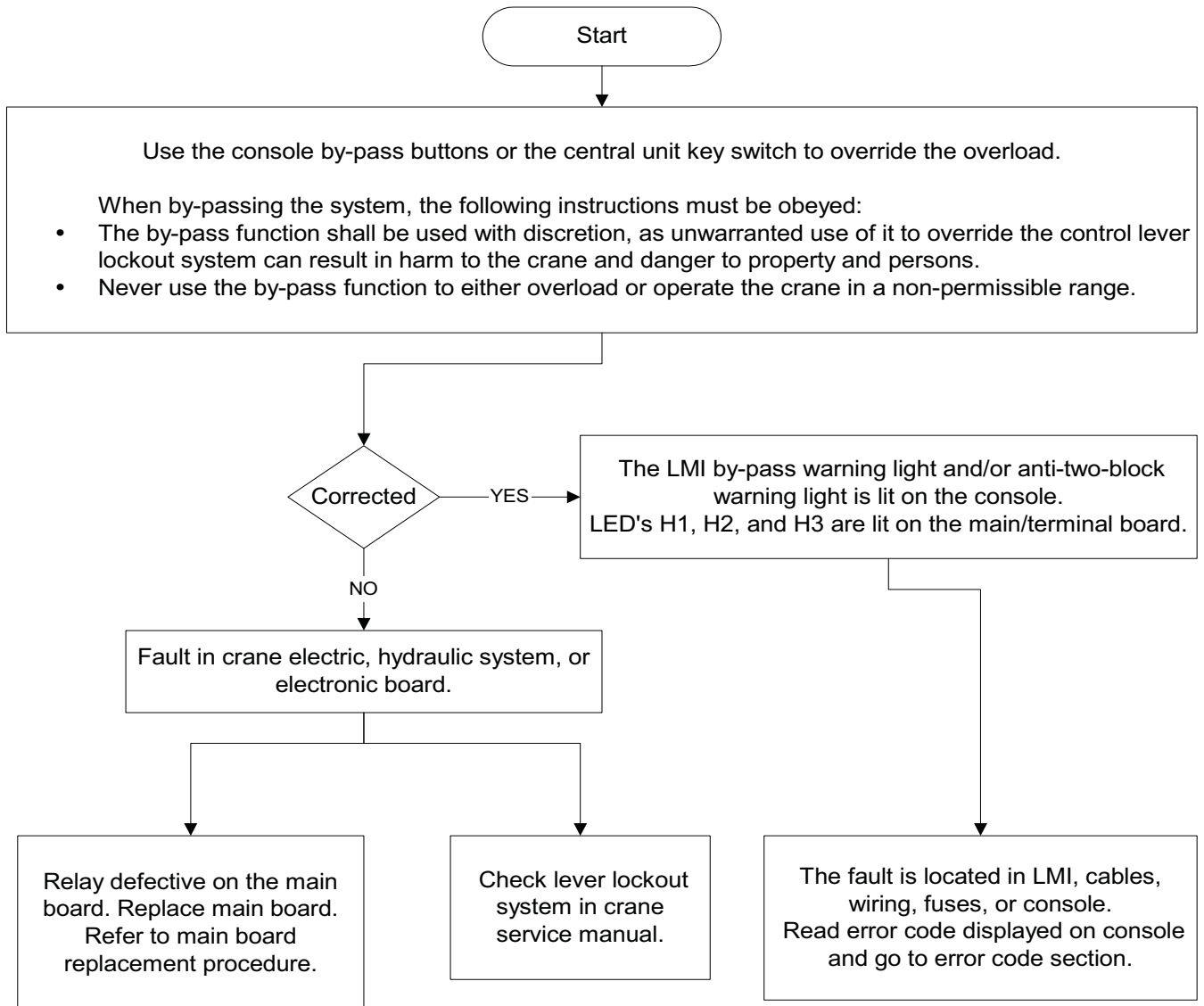

7 NO DISPLAY

PROBLEM: Blank console display with no warning light shown. All crane moments have been stopped.

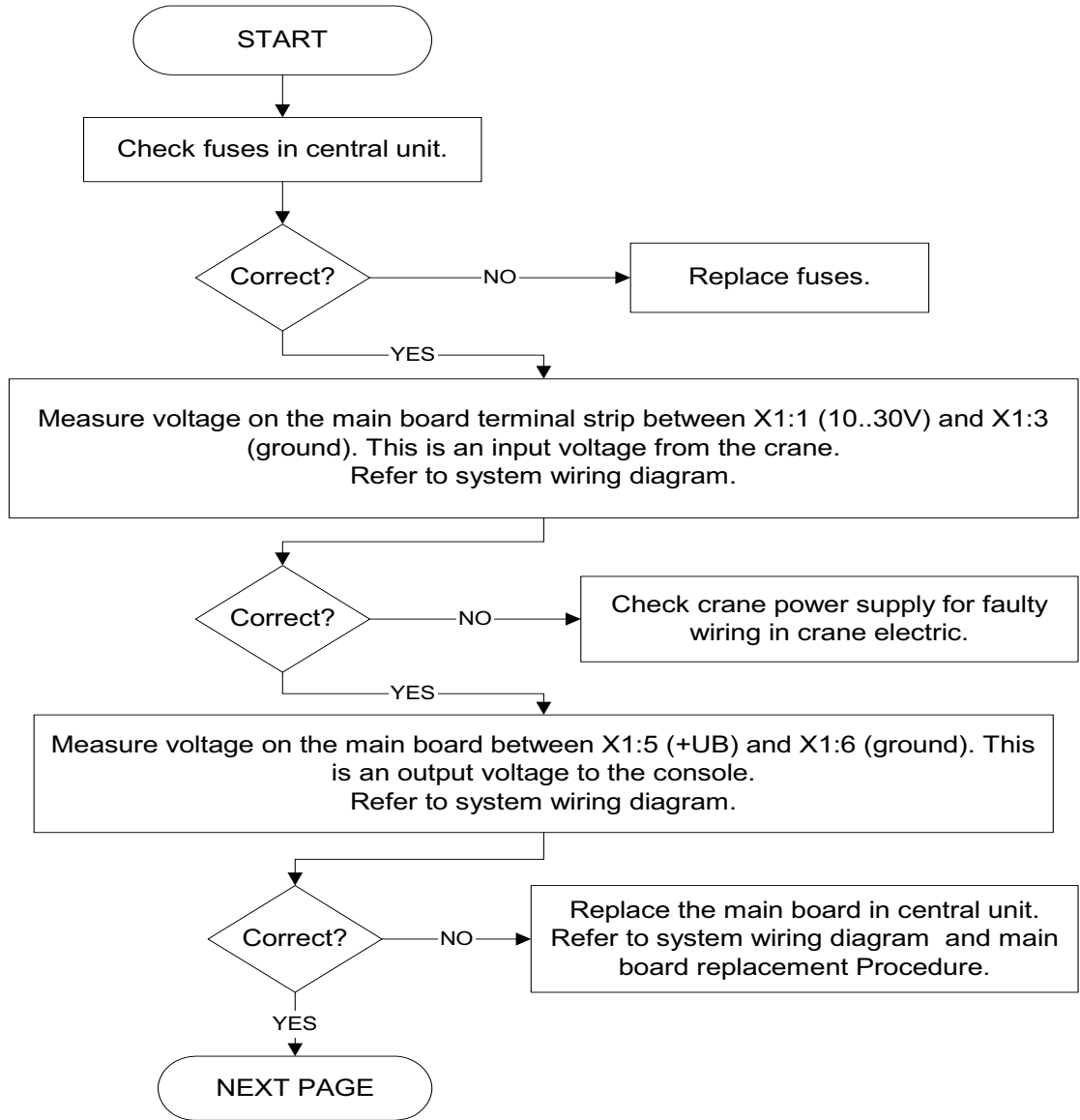

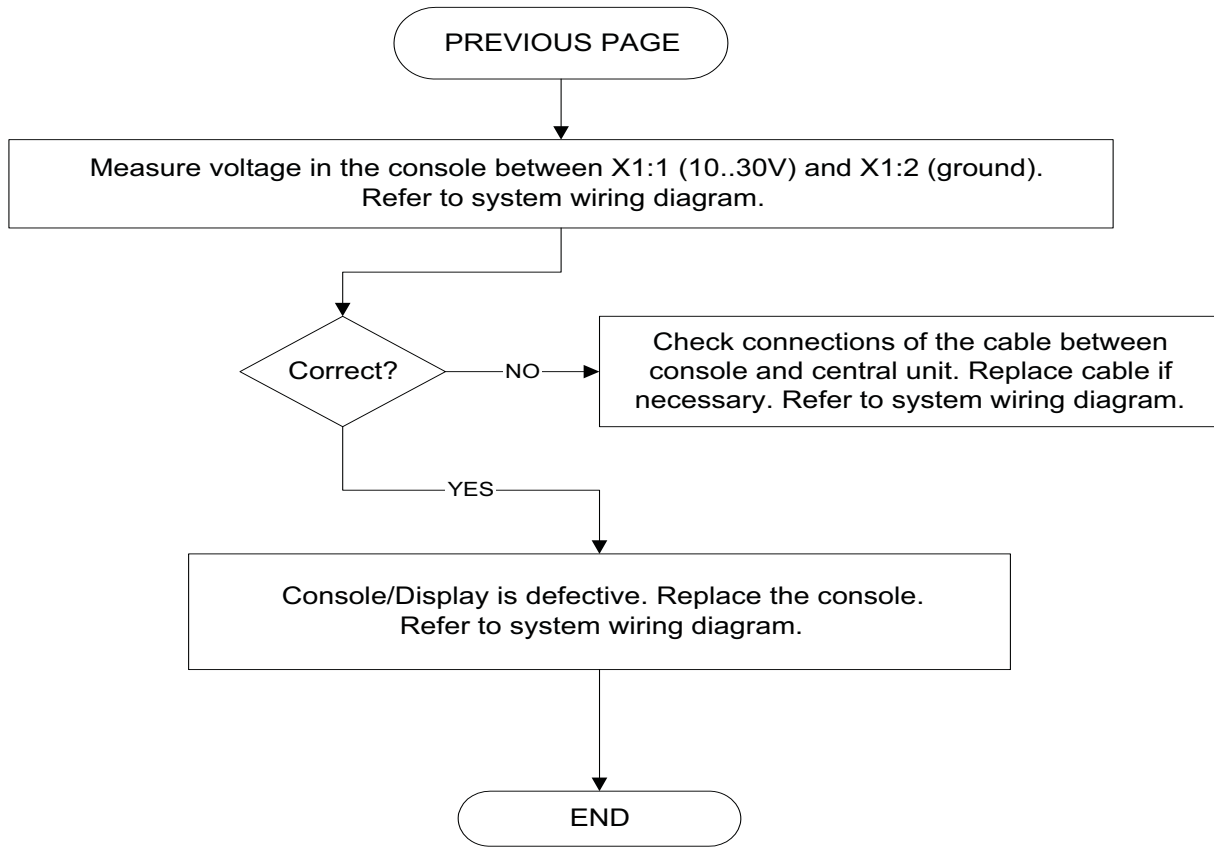

8 ANTI-TWO BLOCK PROBLEM

Refer to the crane owner's manual for a complete description of the anti-two-block system.

PROBLEM: Function of Anti-Two-Block System is faulty.

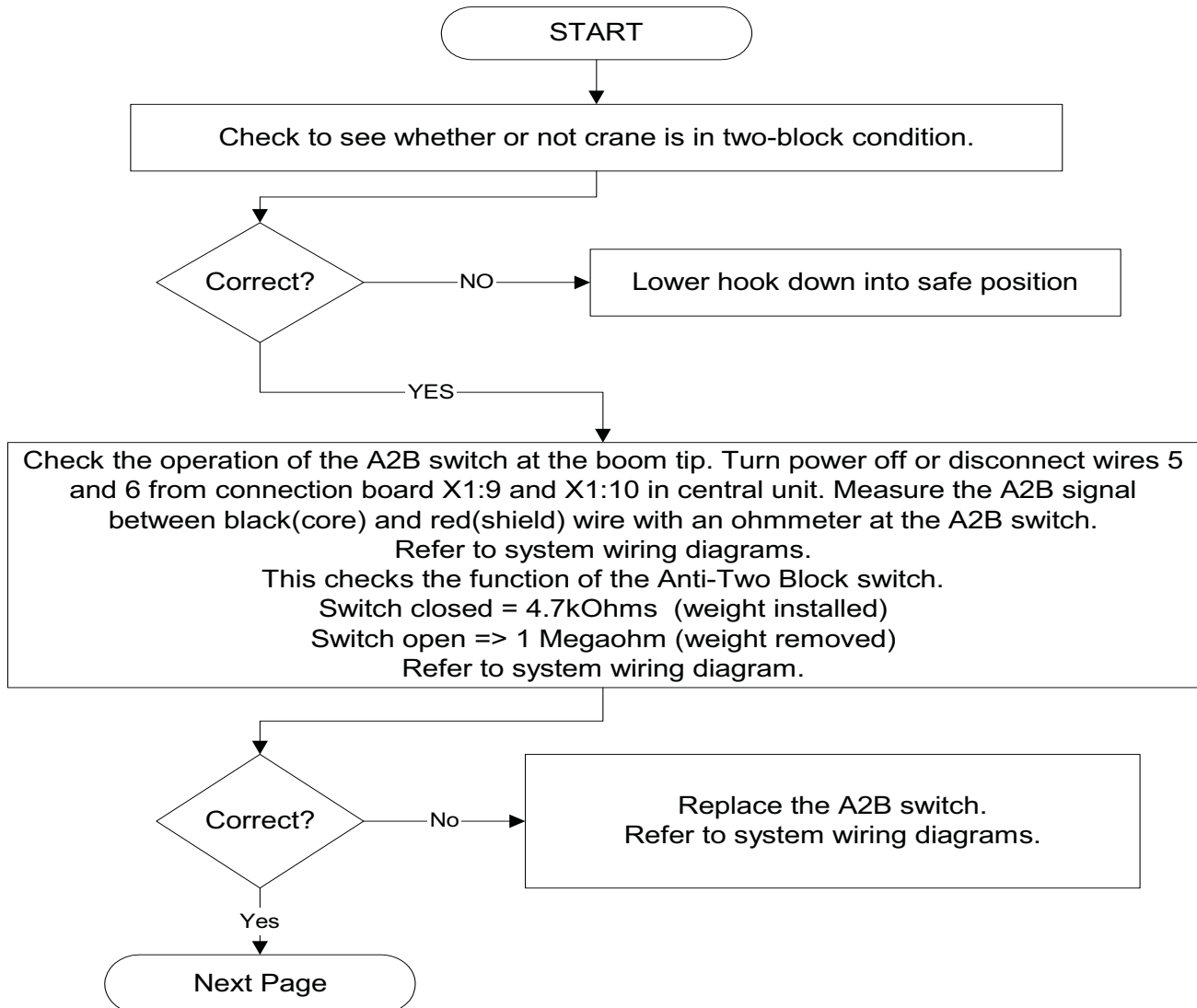

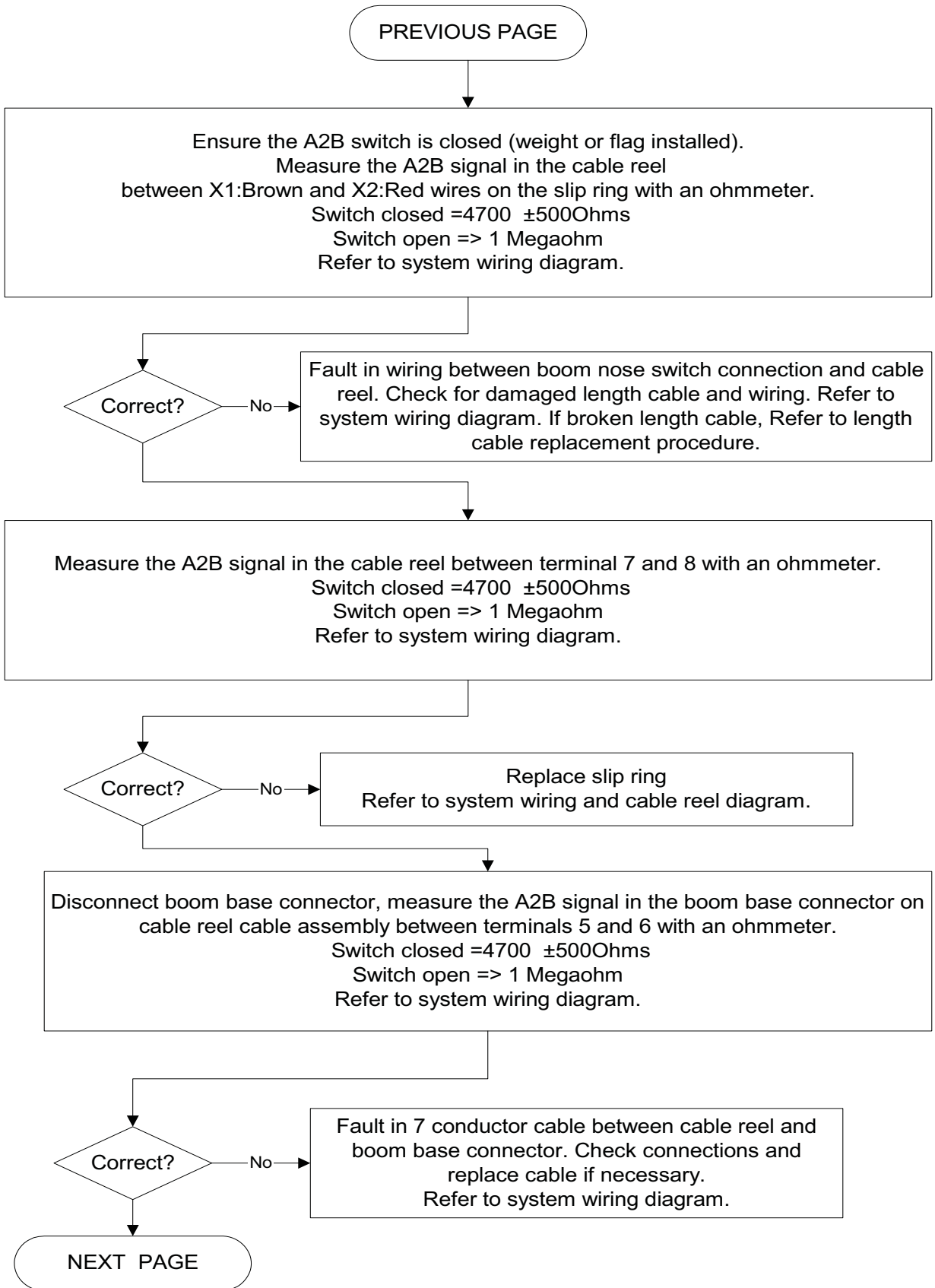

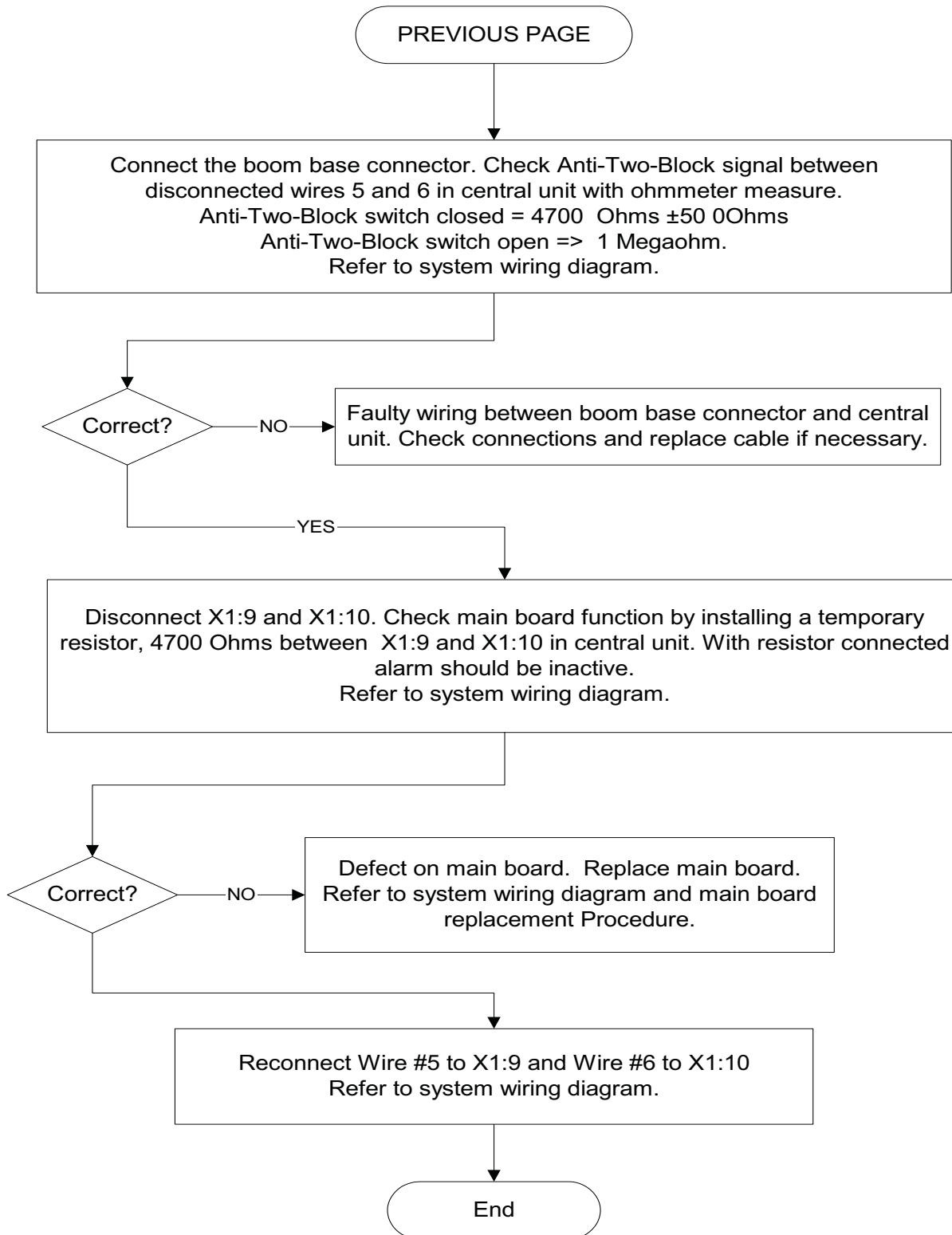

9 LENGTH READING PROBLEM

PROBLEM: Length displayed incorrect. Crane is not in "out of load chart" condition.

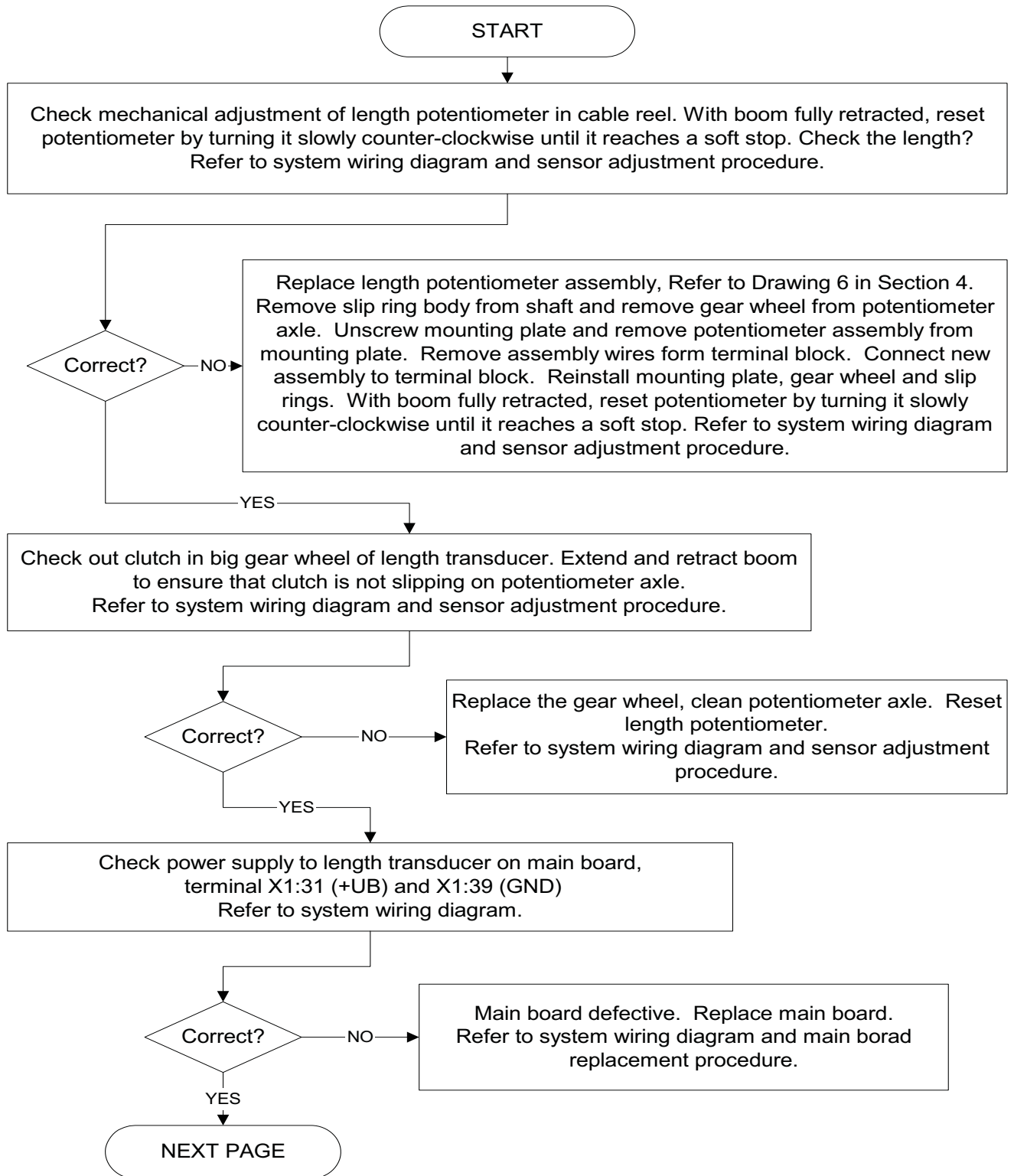

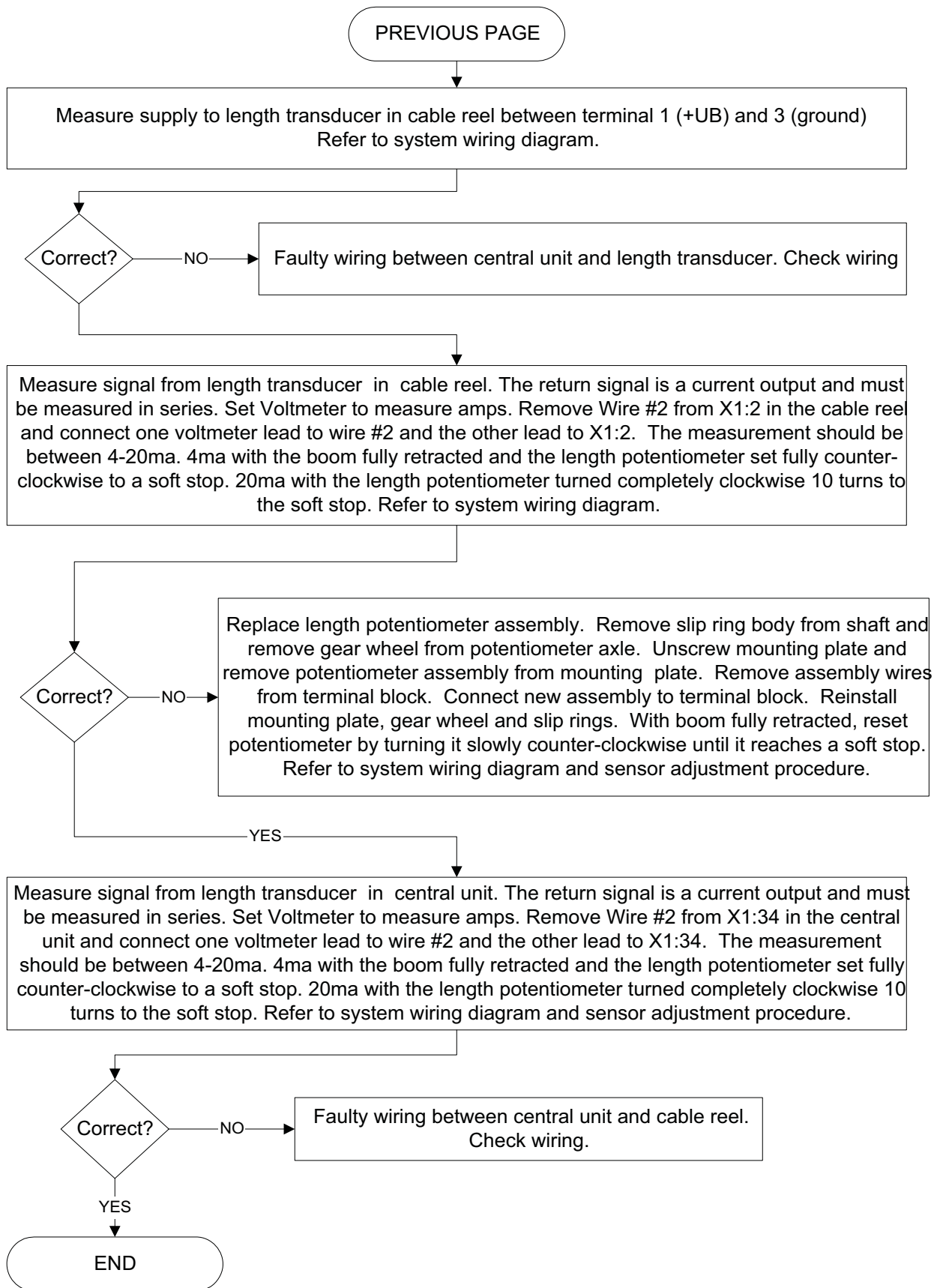

10 ANGLE READING PROBLEM

PROBLEM: Angle displayed incorrect. Crane is not in "out of load chart" condition.

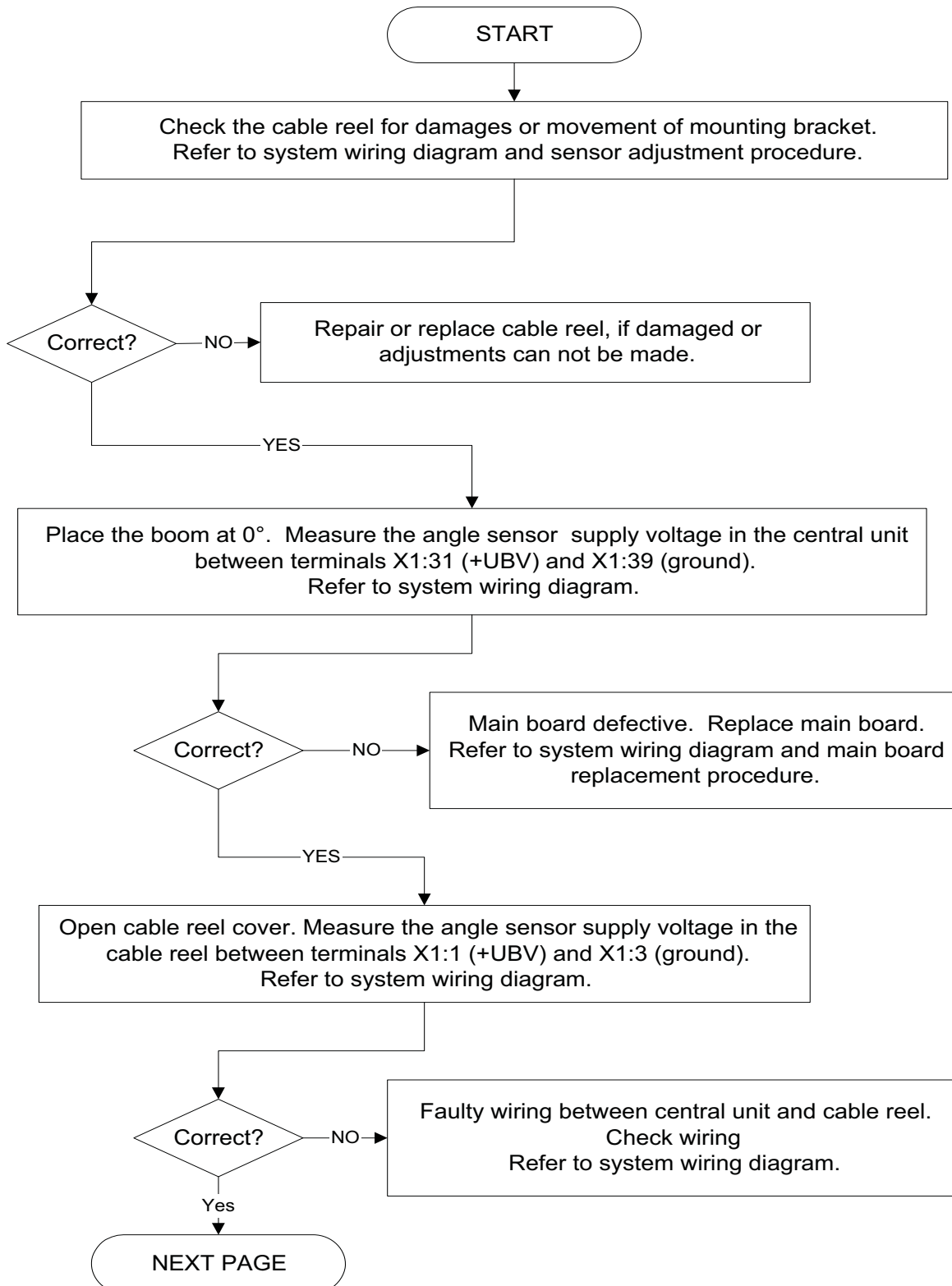

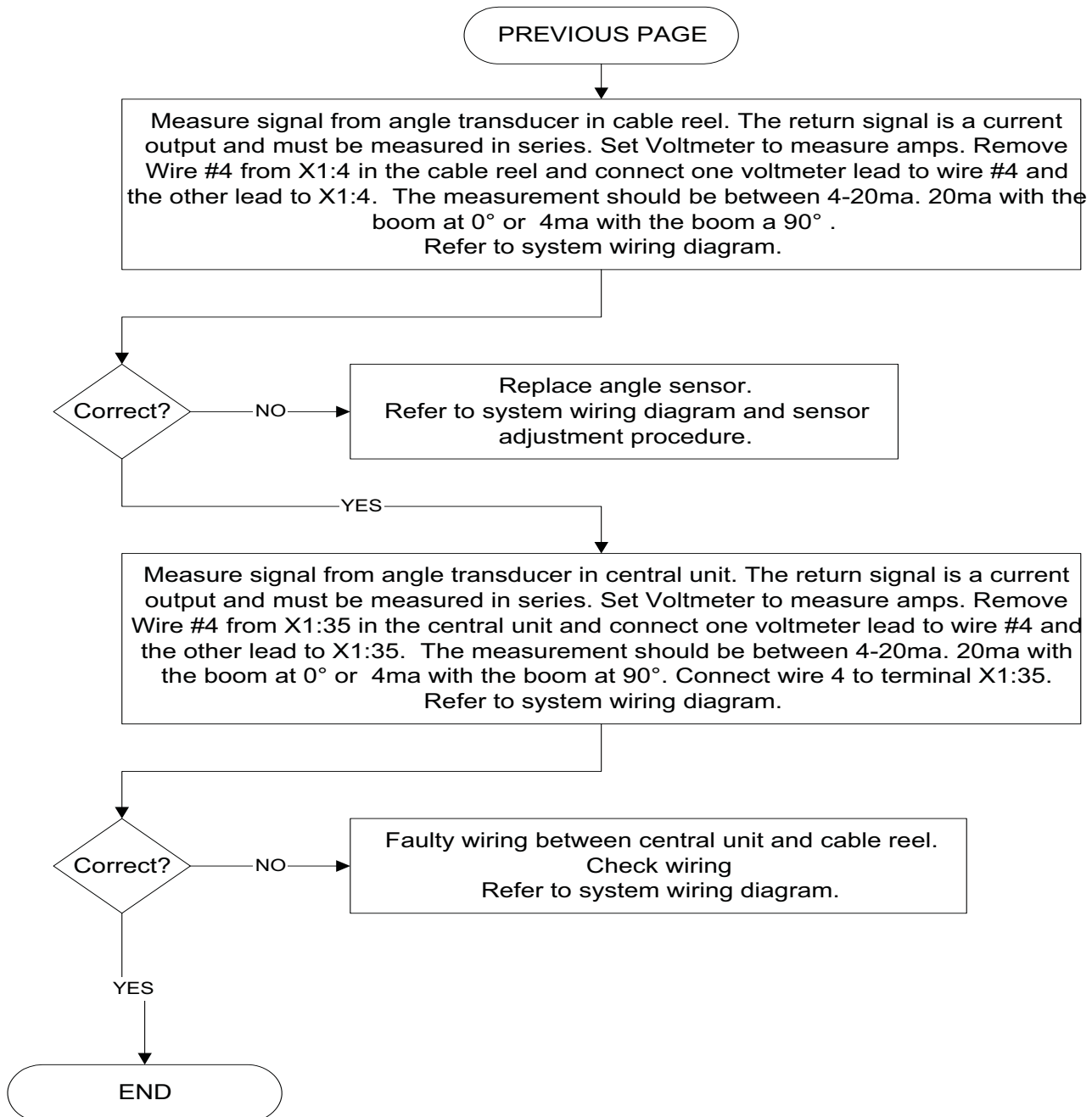

11 LOAD READING PROBLEM

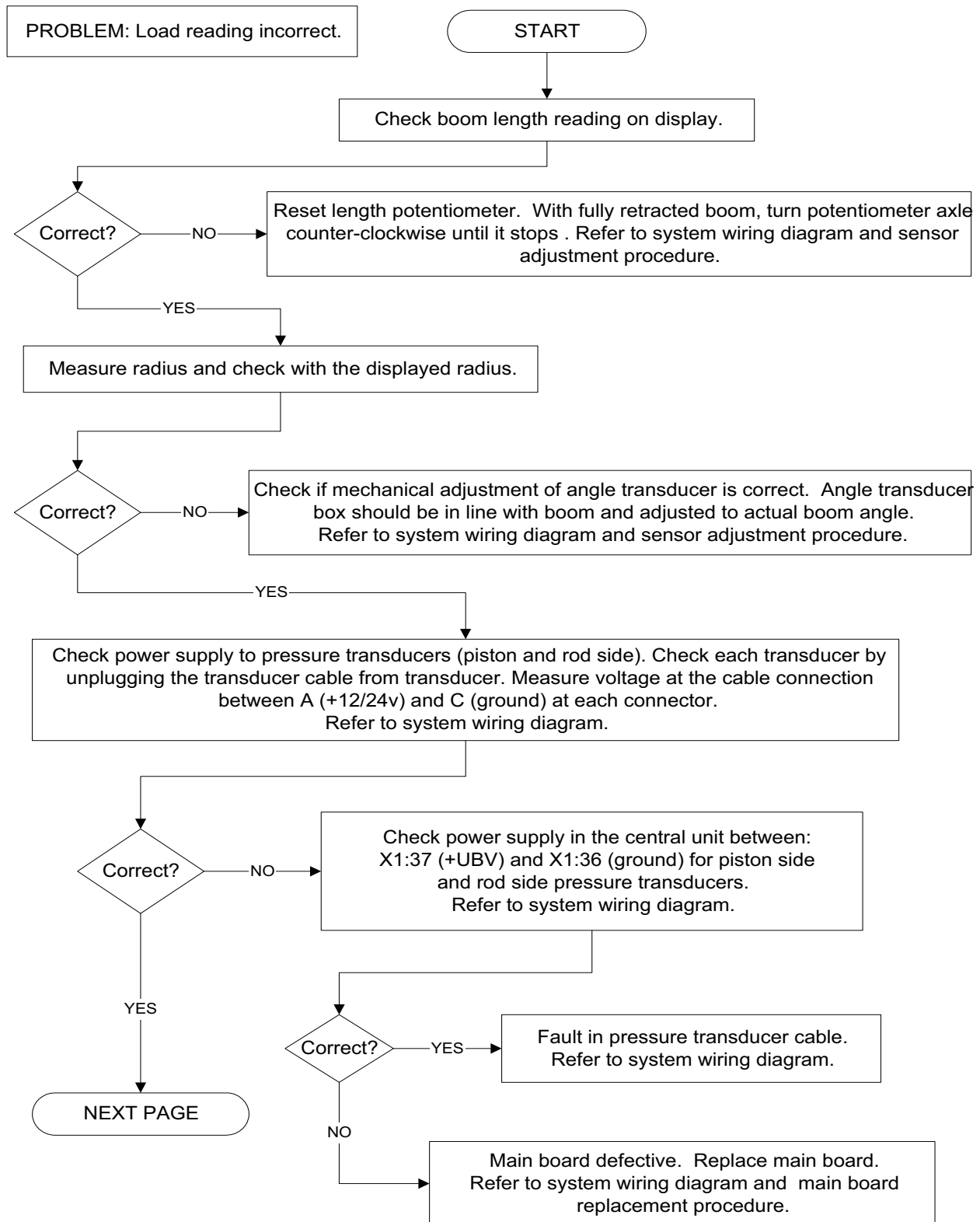

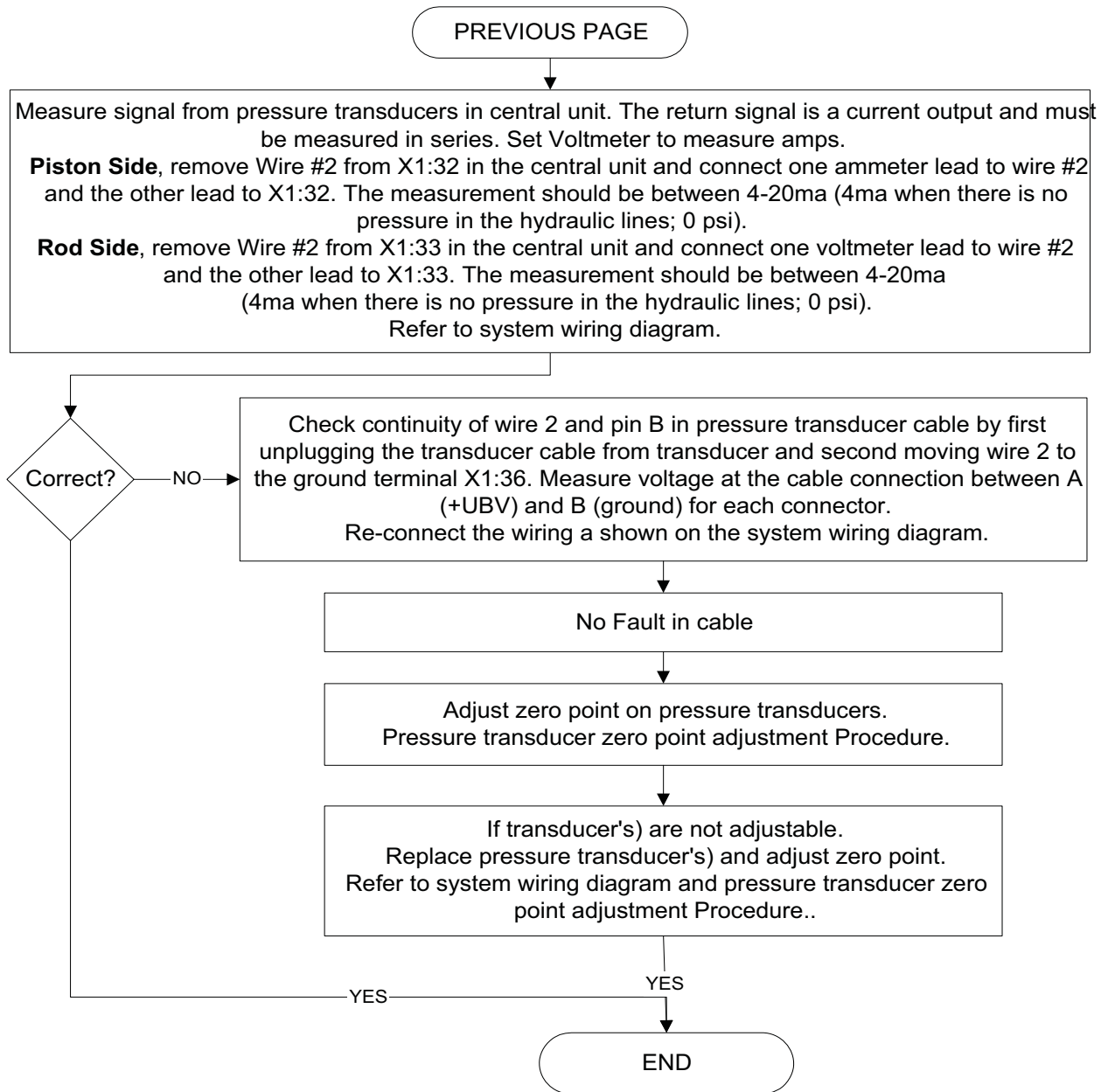

12 DATA TRANSFER CENTRAL UNIT <--> CONSOLE

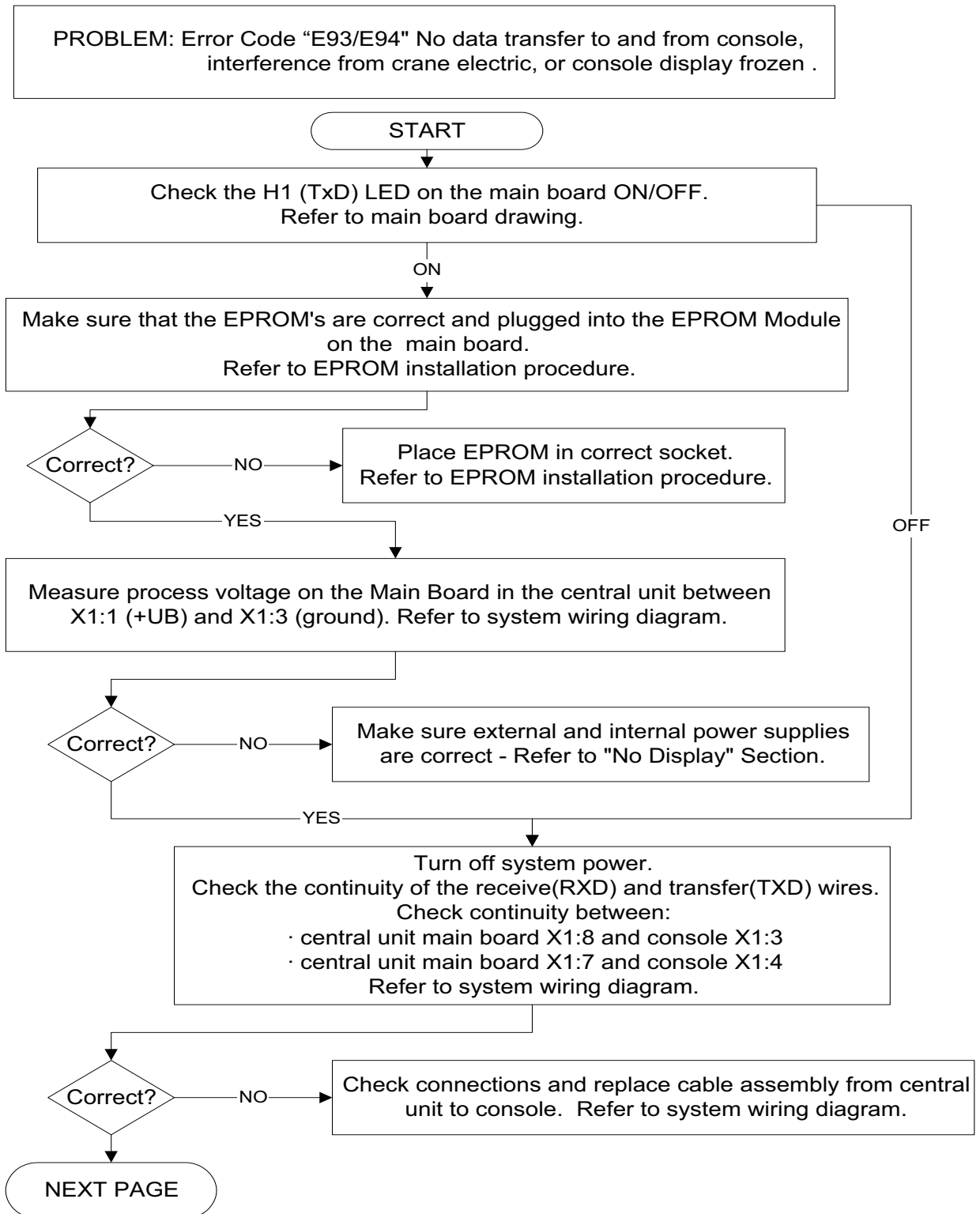

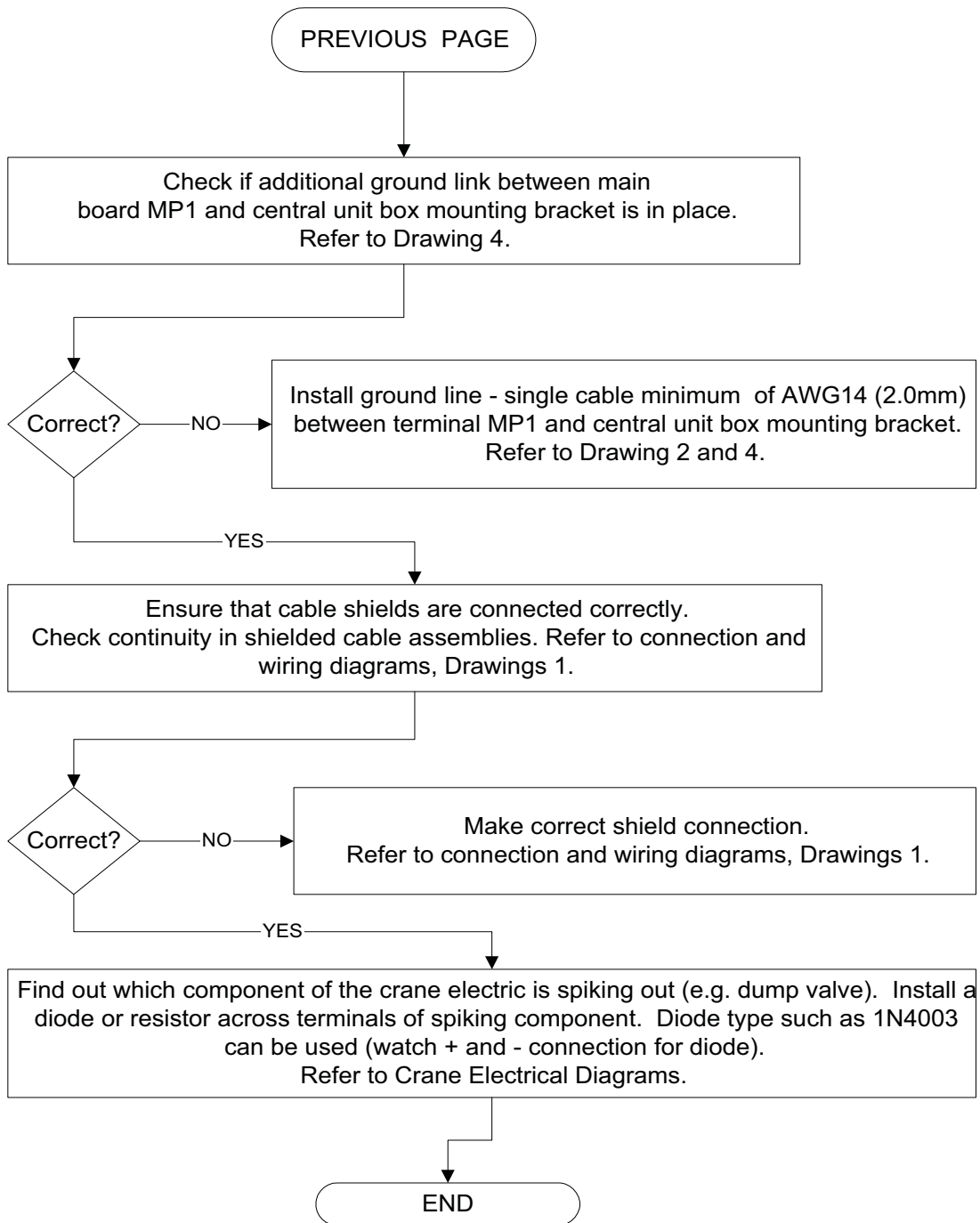

13 DRAWINGS

13.1 System Wiring Diagram

031-300-060-361 Central Unit

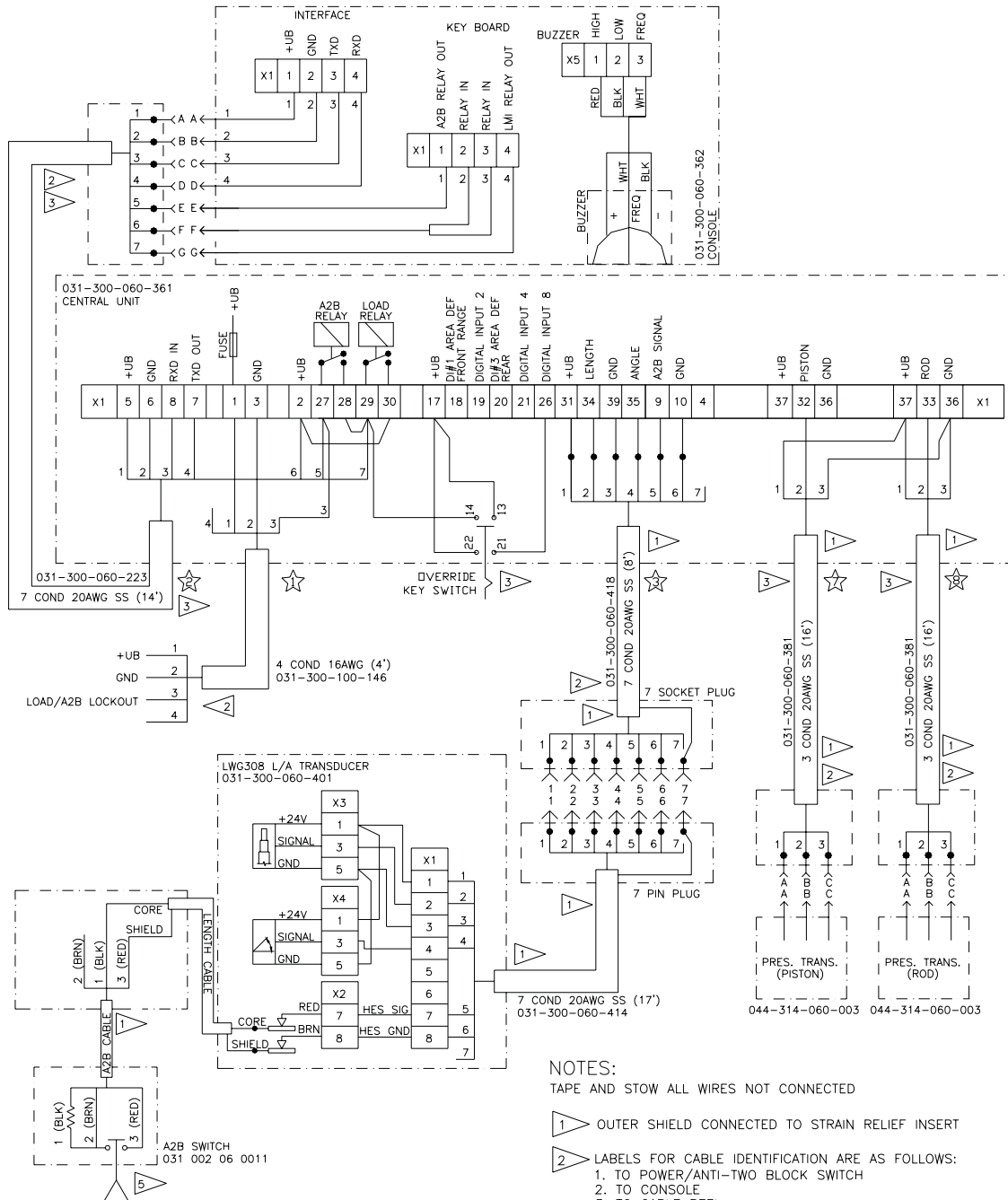

NOTES:

TAPE AND STOW ALL WIRES NOT CONNECTED

- 1 OUTER SHIELD CONNECTED TO STRAIN RELIEF INSERT
- 2 LABELS FOR CABLE IDENTIFICATION ARE AS FOLLOWS:
 - 1. TO POWER/ANTI-TWO BLOCK SWITCH
 - 2. TO CONSOLE
 - 3. TO CABLE REEL
 - 4. HOLE PLUG (NO LABEL REQUIRED)
 - 5. MOISTURE DRAIN (NO LABEL REQUIRED)
 - 6. HOLE PLUG (NO LABEL REQUIRED)
 - 7. TO PISTON SIDE PRESSURE TRANSDUCER
 - 8. TO ROD SIDE PRESSURE TRANSDUCER

STRAIN RELIEF POSITION NUMBER REFERENCE POSITION IN CENTRAL UNIT.

- 3 CABLE LENGTH SHOWN ON CABLE ASSEMBLIES ARE MEASURED FROM STRAIN RELIEF TO STRAIN RELIEF.
- 4 INNER SHIELD CUT AND INSULATED.

13.2 System Wiring Diagram 031-300-060-690 Central Unit

NOTES:

TAPE AND STOW ALL WIRES NOT CONNECTED

1 OUTER SHIELD CONNECTED TO STRAIN RELIEF INSERT

2 LABELS FOR CABLE IDENTIFICATION ARE AS FOLLOWS:
 1. TO POWER/ANTI-TWO BLOCK SWITCH
 2. TO CONSOLE
 3. TO CABLE REEL
 4. HOLE PLUG (NO LABEL REQUIRED)
 5. MOISTURE DRAIN (NO LABEL REQUIRED)
 6. HOLE PLUG (NO LABEL REQUIRED)
 7. TO PISTON SIDE PRESSURE TRANSDUCER
 8. TO ROD SIDE PRESSURE TRANSDUCER

STRAIN RELIEF POSITION NUMBER REFERENCE POSITION IN CENTRAL UNIT.

3 CABLE LENGTH SHOWN ON CABLE ASSEMBLIES ARE MEASURED FROM STRAIN RELIEF TO STRAIN RELIEF.
 4 INNER SHIELD CUT AND INSULATED.

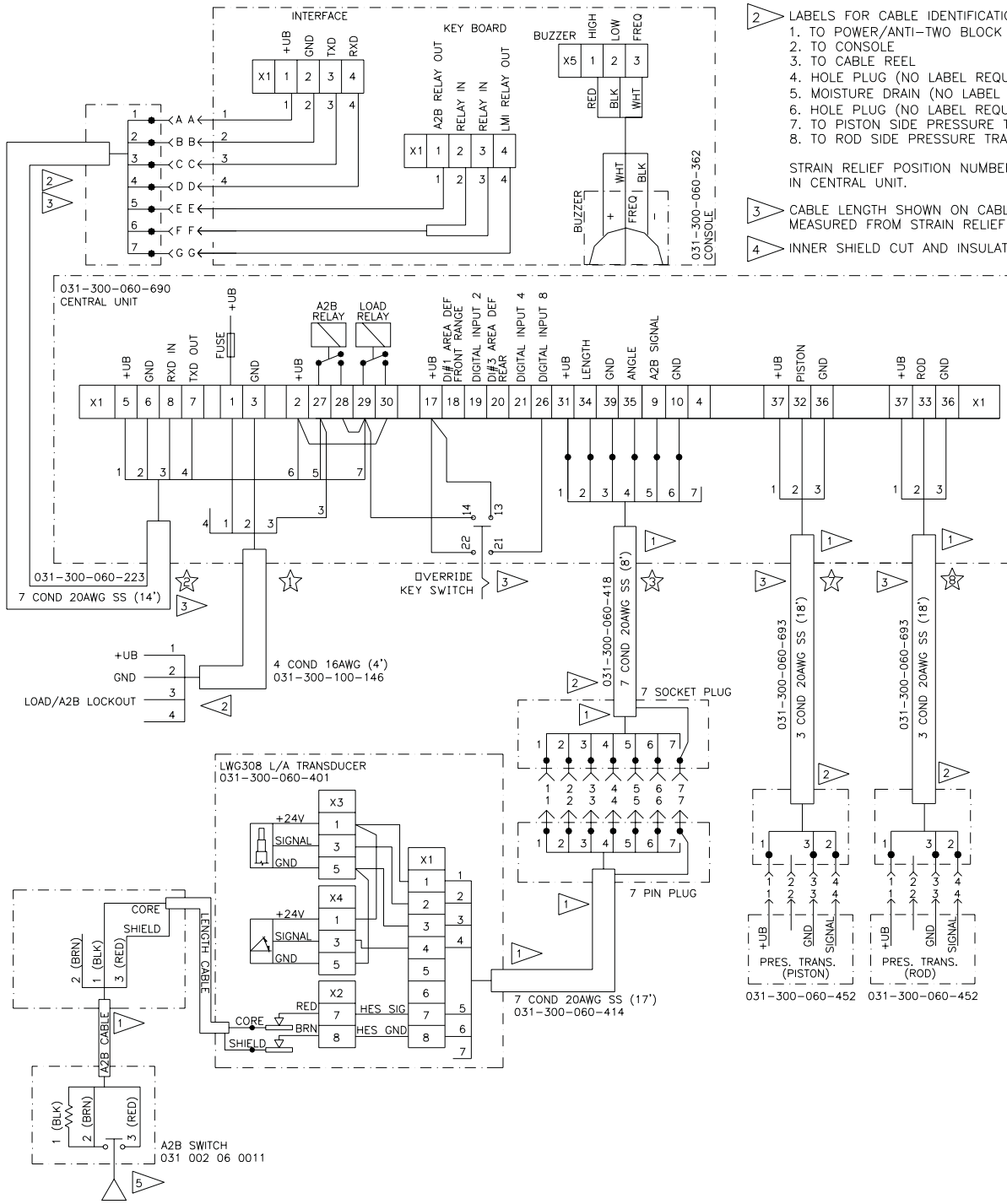

13.3 System Wiring Diagram 031-300-060-645 Central Unit

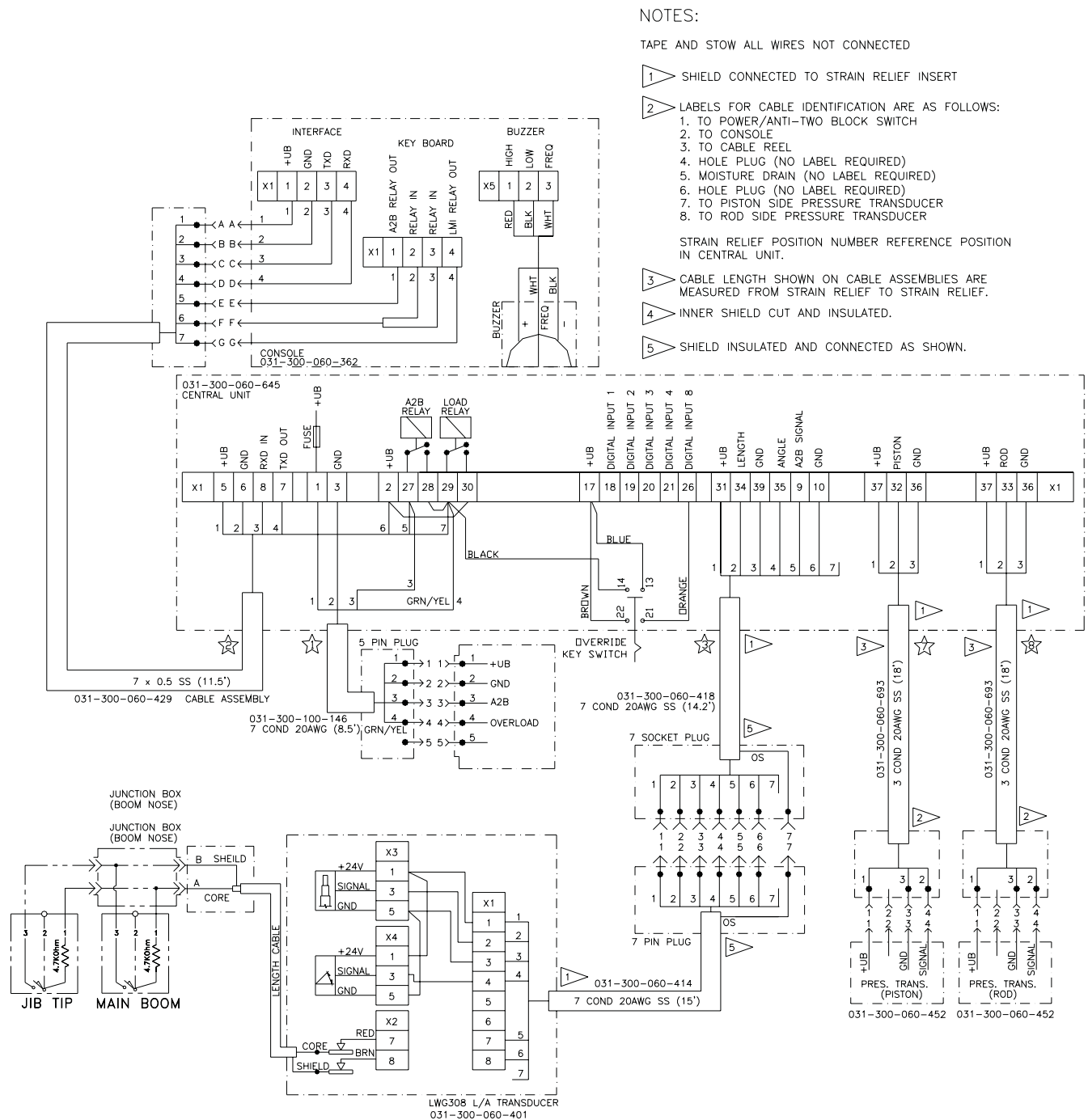

13.4 Central Unit Main Board Termination and Breakdown / Parts List

Refer to system electrical wiring and central unit parts break down diagram inside central unit lid for a complete list of system components and assemblies. For area definition switches and ranges, refer to specific documentation provided by crane manufacture.

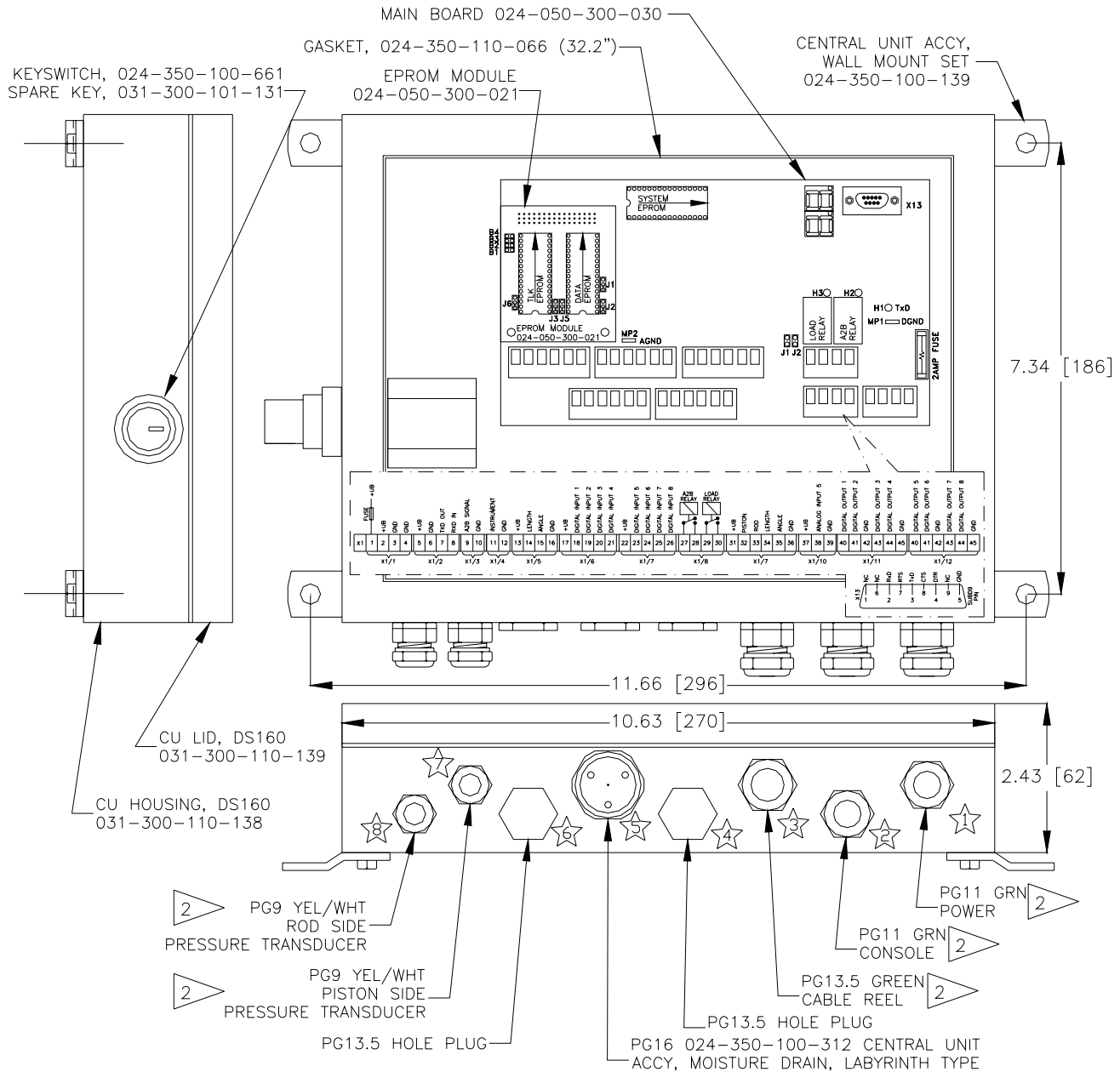

| ITEM_NO | STRAIN RELIEF DESCRIPTION |
|-----------------|-----------------------------|
| 021-441-060-409 | PG 9 4-6mm, YELLOW/WHITE |
| 000-214-340-009 | PG 9 HOLEPLUG |
| 031-300-050-255 | PG11 GREEN EMI/RFI 8-10.5mm |
| 000-214-340-011 | PG11 HOLE PLUG |
| 021-441-090-711 | PG11, 5.5mm-9mm BLACK+WHITE |
| 000-214-261-109 | PG11/PG 9 REDUCER |

| ITEM_NO | DESCRIPTION |
|-----------------|---------------------|
| 000-214-340-013 | PG13.5 HOLEPLUG |
| 000-214-261-309 | PG13.5/PG 9 REDUCER |
| 000-214-261-311 | PG13.5/PG11 REDUCER |
| 000-214-210-009 | NUT, PG9 |
| 000-214-210-011 | NUT, PG11 |
| 000-214-210-013 | NUT, PG13.5 |

13.5 Central Unit Main Board Layout

BOARD P/N 024-050-300-030

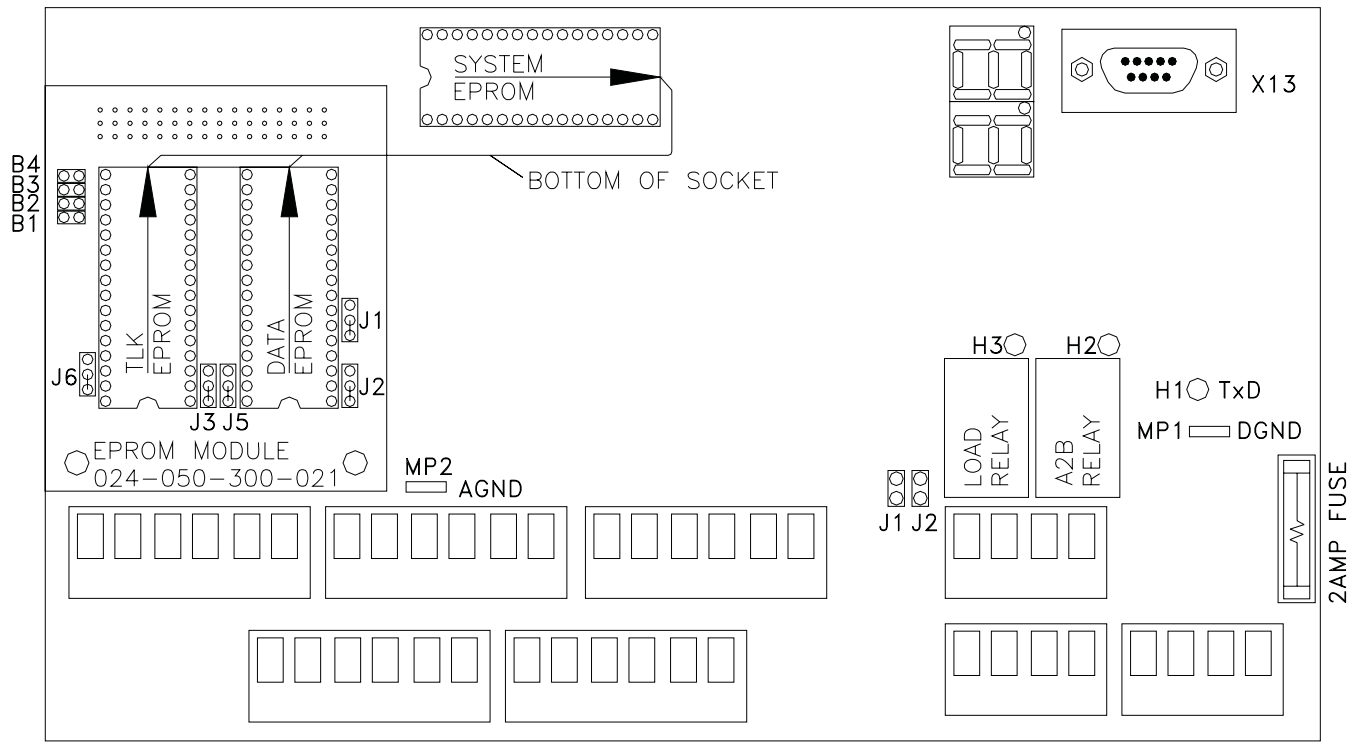

MP1 = DGND
MP2 = AGND

LED'S

- H1 – TxD on when transferring and receiving data form console
- H2 – A2B on when A2B relay energized
- H3 – LOAD on when LOAD relay energized

Two Digit Indication, normal two zeros or will show an error code if error condition occurs

Fuse - 2AMP

13.6 Console DS160/0005 / Parts List

Part Number **031-300-060-362** (Refer to system wiring diagram for 050-160-060-005 console wiring connections to central unit)

| NO. | PART NO. | QTY | DESCRIPTION |
|-----|-----------------|-----|--|
| 01 | 050-160-120-005 | 1 | DECAL, DS160/5 FRONT FOIL |
| 02 | 031-300-060-382 | 1 | MOUNTING ARM, RAM MOUNT B-101 W/ 1" BALL |
| 03 | 050-000-100-267 | 1 | INDICATOR, DISPLAY DS160/0005 |
| 04 | 050-050-300-030 | 1 | MAIN BOARD, D160/0005 |
| 05 | 031-300-050-223 | 1 | FUSE, 2 AMP AUTO |
| 06 | 050-050-300-036 | 1 | KEYBOARD, DS160 CONSOLE /0005 |
| 07 | 031-300-100-391 | 1 | CONNECTOR, 7-PIN RECEPTACLE |
| 08 | 024-350-100-312 | 1 | MOISTURE DRAINAGE PLUG |
| 09 | 050-000-100-274 | 1 | ALARM, DS160 CONSOLE /0005 IP65 W/ CABLE |
| 10 | 050-160-100-005 | 1 | HOUSING, COMPLETE DS160/0005 W/ DECAL |

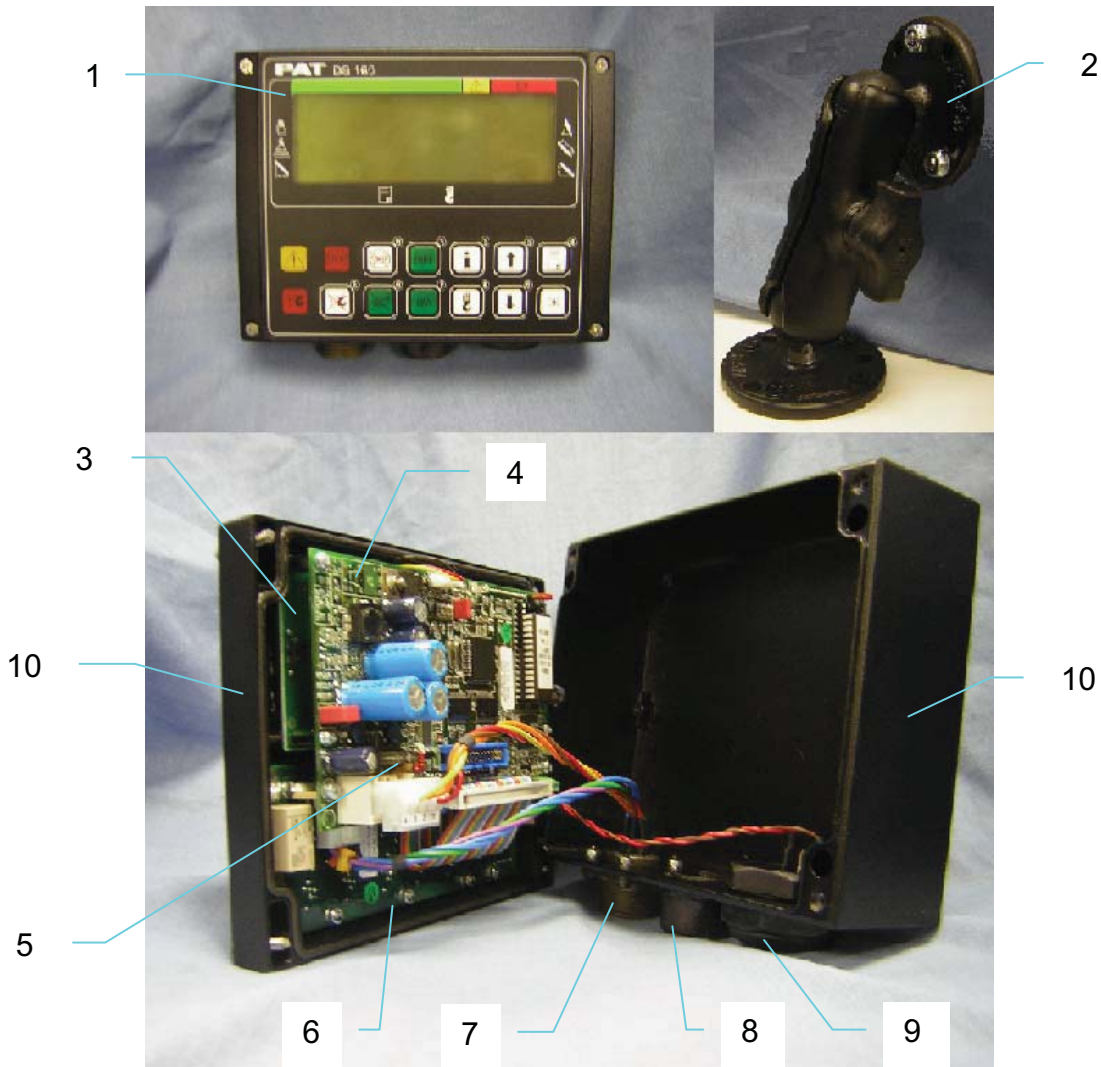

13.7 Pressure Transducer (DAVS314)

Part Number 044-314-060-003 (obsolete, replaced by 031-300-060-452)

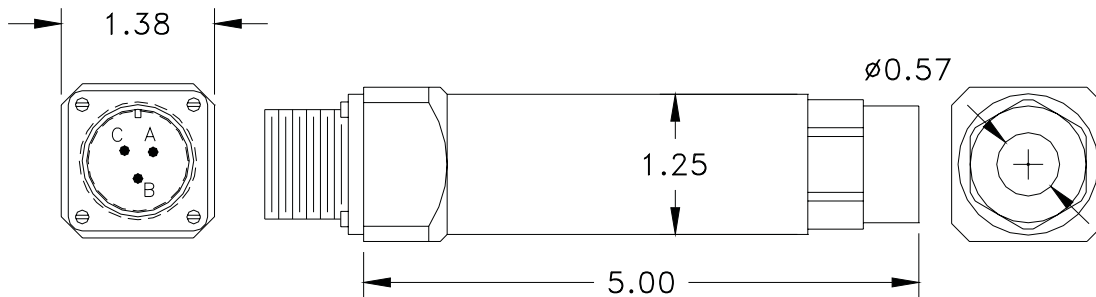

There are no spare parts associated with the pressure transducer; the following parts are used to make a hydraulic connection to a 9/16-18 JIC fitting.

000-209-140-016 Pressure Transducer Cutting Ring Seal

000-214-600-093 Pressure Transducer Adapter, 9/16-18 JIC 37 X 16M X 1.5

Replacement DAVS314 pressure transducers are no longer available. Pressure transducer replacement kit **031-300-101-515** contains all necessary items required to change to the updated DAVS300/3401 pressure transducer.

13.8 Pressure Transducer (DAVS300 / 3401)

Part Number **031-300-060-452** (4.20mA, 300 bar, M12, 9/16-18)

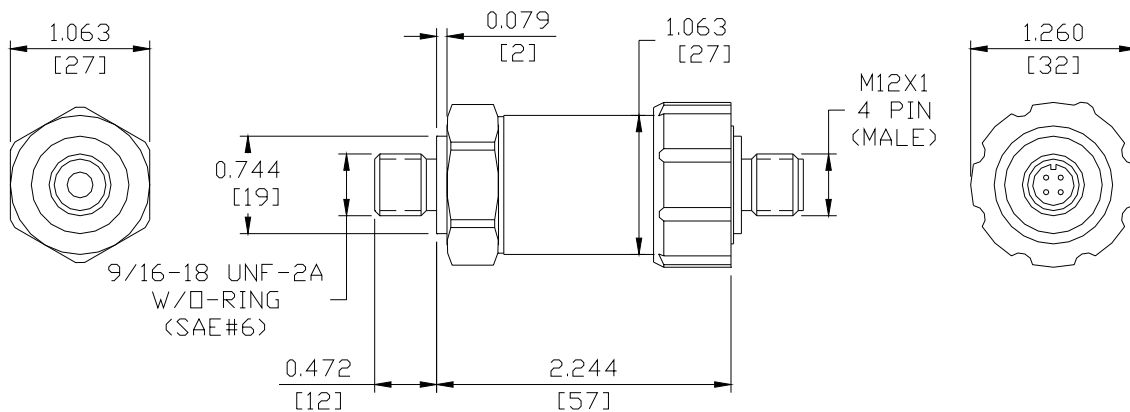

There are no spare parts associated with the pressure transducer; the following parts are use to make a hydraulic connection to a 9/16-18 JIC fitting.

000-209-140-016 Pressure Transducer Cutting Ring Seal

031-300-050-689 Pressure Transducer Adapter, 9/16-18 UNF-2B, M16 X 1.5

13.9 Cable Reel

Part Number **031-300-060-401** (Refer to system wiring diagram in central unit for assembly part numbers)

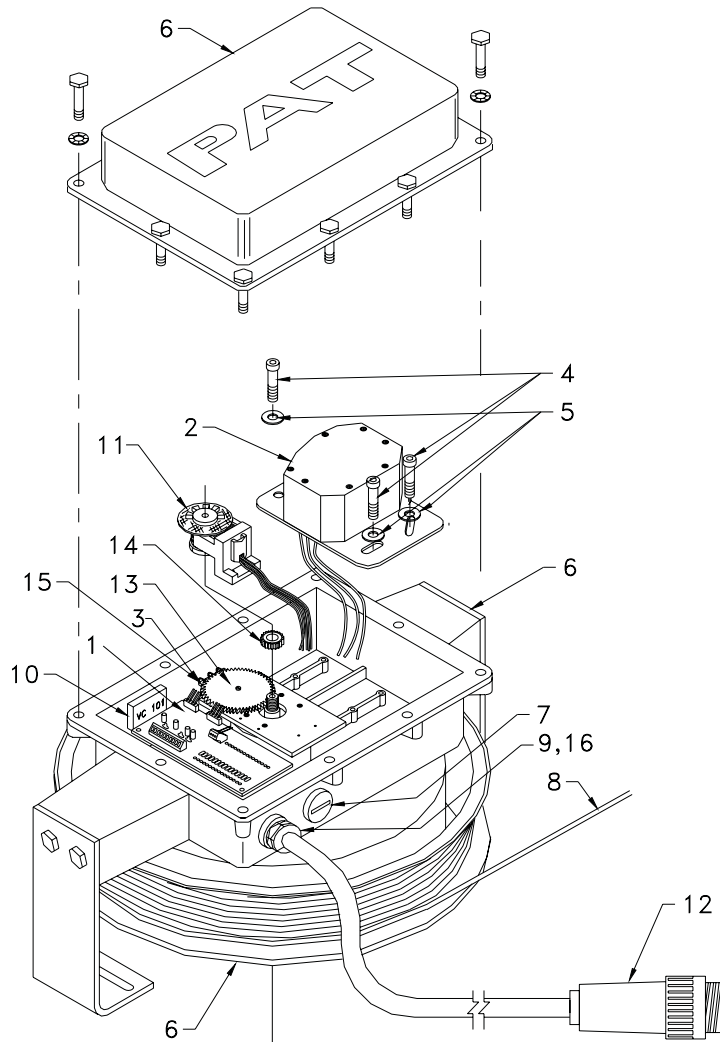

| NO. | PART NO. | QTY | DESCRIPTION |
|-----|-----------------|------|---|
| 01 | 068-000-300-060 | 1 | BOARD, TERMINAL W/ EMC FILTERS |
| 02 | 064-143-060-005 | 1 | ANGLE SENSOR WG103/0007 |
| 03 | 068-000-300-018 | 1 | SENSOR, LENGTH POT. LPE0018, CURRENT 4..20mA |
| 04 | 002-050-206-012 | 2 | SCREW M6 X 12 HEX SOCKET CAP |
| 05 | 000-207-010-064 | 2 | WASHER M6 FLAT |
| 06 | 068-000-100-152 | 1 | HOUSING KT200 |
| 07 | 000-214-340-013 | 1 | PG13.5 HOLE PLUG |
| 08 | 000-673-020-002 | 139' | CABLE, LENGTH SINGLE CORE |
| 09 | 031-300-050-255 | 1 | STRAIN RELIEF, PG11 GREEN |
| 10 | 031-300-100-206 | 1 | CHEMICAL, CORROSION INHIBITOR |
| 11 | 068-000-100-064 | 1 | SLIP RING ASSEMBLY 2 POLE |
| 12 | 031-300-060-414 | 1 | CABLE ASSEMBLY, 17' |
| 13 | 068-000-110-038 | 1 | GEAR, 75 TOOTH FOR LWG208 |
| 14 | 006-800-005-001 | 1 | GEAR, 25 TOOTH FOR LWG208 |
| 15 | 092-000-060-202 | 1 | CABLE, MODULAR LENGTH & ANGLE, SENSOR 3p 32cm |
| 16 | 000-214-261-311 | 1 | STRAIN RELIEF ACCY, PG13.5-11 REDUCER |

14 PROCEDURES

14.1 EPROM Location and Installation Procedure

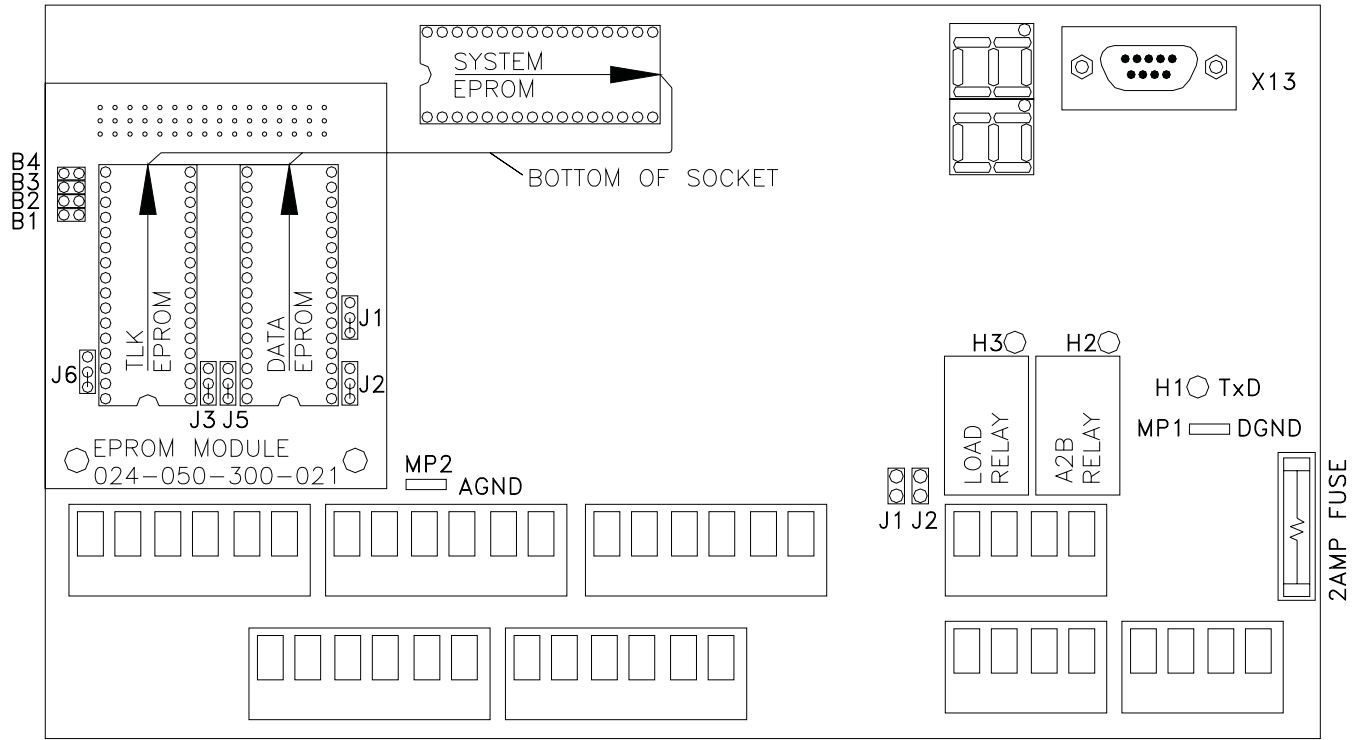

- Ensure the notch is in the correct direction.
- The DATA, TLK, and SYSTEM EPROM's fill the bottom of the socket as shown by the arrows.
- Place EPROM's in the correct EPROM socket as shown.

14.2 Main Board Replacement Procedure

Refer to Drawing 13.2, central unit parts list for board location.

1. Turn system power off.
2. Remove the central unit lid.



NOTE: Take care not to damage the boards with the screwdriver, when removing and inserting screws.

NOTE: Use care when lifting the CPU module board and analog input module from the main board, due to the fact that these boards have pins on the bottom side, which insert into the main board.

3. Disconnect the wiring by unplugging terminal blocks, ensure all blocks and wires are marked to simplify installation. If disconnecting wires from terminal blocks refer to the system wiring diagram in this manual or in the central unit lid for wiring connections.
4. Remove the EPROM module board by taking out the 2 small Philips screws holding it in place.
5. Remove the system EPROM.
6. Remove the main board by taking out the 4 Philips screws holding it in place.
7. Take notice of the orientation of the main board in the central unit. Remove main board and place in the packing material that the replacement main board came in.
8. Carefully insert the new main board in place.
9. Insert the 4 Philips mounting screws.
10. Insert system EPROM.
11. Insert EPROM module board by lining up the pins into the sockets X14 and the 2 screw holes.
12. Insert the 2 small Philips screws and washers.
13. Connect the X1 terminal blocks/wires to the main board. Refer to the system wiring diagram in this manual or in the central unit lid for wiring connections.
14. Turn power on and test system.
15. Inspect the gasket for nicks, cuts, or damages before installing and tightening the cover.

14.3 Calibration of Sensors Procedure

To access the calibration sensors screen use the following procedure.

1. From the operating screen, simultaneously press and hold  and  for approximately 5 seconds.
2. The screen show the following selections:

| |
|-------------------|
| CALIBRATE SENSORS |
| EXIT |

3. Use the 'UP' and 'DOWN' arrows to high light (text flashes) calibrate sensors, and then press 'OK' to display a similar screen as shown below: Note: the displayed length indication is noted by XX.X in following step.

| | | |
|-----|--------|---------|
| PIS | 0.500V | 000 PSI |
| ROD | 0.500V | 000 PSI |
| LEN | 0.500V | XX.X FT |
| ANG | 0.500V | 90 DEG |

Go to the following selection for the pressure transducer, length, or angle procedure below to complete sensor calibration after confirming the following step.

4. Acknowledge the sensor selection by selecting yes or no.

| |
|-------------------|
| CALIBRATE SENSOR? |
| YES |
| NO |

Proceed to the following sections for pressure transducer, length, and angle calibration procedures.

14.3.1 Pressure Transducer Calibration Procedure

After selecting 'PIS' or 'ROD' in steps 1 through 4 at the beginning of this section complete the following procedure. The zero setting consists of defining zero-point offset. The zero point offset is added to the transducer measurement to calculate the real physical pressure or force.

To define the zero-point offset the pressure transducer or force sensor must be in equilibrium (no load condition). Therefore the boom must be lowered all the way down (no rest pressure) and the hydraulic hoses disconnected from the pressure transducers.

CAUTION: Ensure there is no pressure in the hydraulic line when disconnecting the hoses from pressure transducers.

| |
|---|
| BOOM DOWN COMPLETELY AND DISCONNECT HYDR |
| OK |
| EXIT |

Press the 'OK' button to zero the selected piston or rod side pressure transducer. The rod and piston side pressure transducers are zeroed individually; therefore, you must complete this procedure for both piston and rod side pressure transducers.

Press **EXIT** to leave calibration or select the 'CALIBRATE SENSORS' to calibrate another sensor.

14.3.2 Length Sensor Calibration Procedure

After selecting 'LEN' in steps 1 through 4 at the beginning of this section complete the following procedure.

1. Fully retract the main boom and adjust length pot in cable reel define in the Cable Reel LWG308/0001 Adjustment Procedure in this manual.

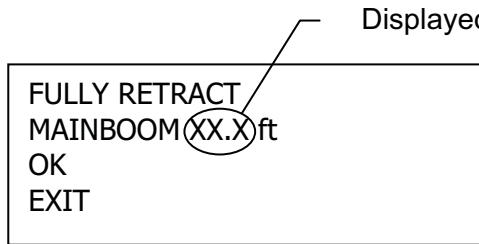

Displayed length indication

Note: the displayed length indication is noted by XX.X in following steps.

2. Verify the boom retracted boom length is correct. If incorrect, adjust length pot in cable reel define in the Cable Reel LWG308/0001 Adjustment Procedure.

Note: The retracted main boom length may not be indicating correctly until after the calibration procedure step 2. The display length is not the load chart length. The correct display length can be found in the LMI section of the crane operator's manual. If the indication is more than 0.2 feet incorrect, recheck step 1.

3. Press the 'OK' button.

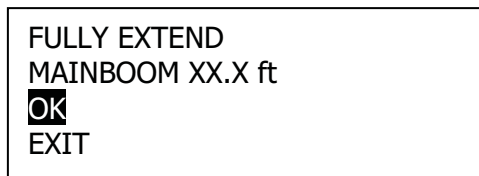

4. Fully extend the main boom.

Press the 'OK' button.

After 'OK' the system request the length sensor calibration is saved.

14.3.3 Angle Sensor Calibration Procedure

After completing steps 1 through 4 at the beginning of this section, boom down to a flat angle and mechanically adjust the angle sensor. The angle should be set to be +/-0.0 of the measured angle. Material – calibrated inclinometer.

Displayed angle indication

BOOM ANGLE 0.0 DEG
 MECH. 0-CALIBRATION
 OK
 EXIT

Note: the displayed angle indication is noted by XX.X in following steps.

Press “OK” when the sensor is mechanically set.
Pressing “OK” confirm the mechanical adjustment.

BOOM TO 40.0 DEG
 XX.X DEG

 EXIT

Boom up to the next correction angle, 40 DEG (range 35° - 45°). Note: When the boom angle is within the calibration range, the screen will add the ‘CHANGE’ and ‘OK’ text to the screen similar to the screen below. Measure the boom angle with the inclinometer and when the boom is positioned in the calibration range, compare the measured angle to the displayed angle.

BOOM ANGLE 40.0 DEG
 CHANGE XX.X DEG
 OK
 EXIT

Use the ‘UP’ and ‘DOWN’ arrow buttons to select “CHANGE” then press ‘OK’. The displayed angle should now be flashing.
Use the ‘UP’ and ‘DOWN’ arrow buttons to adjust the indicated angle to match the measured angle. After the display shows the correct angle, press ‘OK’.

Complete the above procedure to set the correction factor at 60° and 70° boom angle.
After ‘OK’ is selected the system defines a high boom correction angle, 60 DEG (range 55° - 65°).
After ‘OK’ is selected the system defines a high boom correction angle, 70 DEG (range 65° - 75°).
After ‘OK’ the system request the angle sensor calibration is saved.

SAVE CALIBRATION ?
 YES
 NO

Use the ‘UP’ and ‘DOWN’ arrow buttons to select ‘YES’, which should be flashing then press ‘OK’ to confirm calibration.

Press **EXIT** to leave calibration or select the ‘CALIBRATE SENSORS’ to calibrate another sensor.

14.4 Cable Reel LWG308/0001 Adjustment Procedure

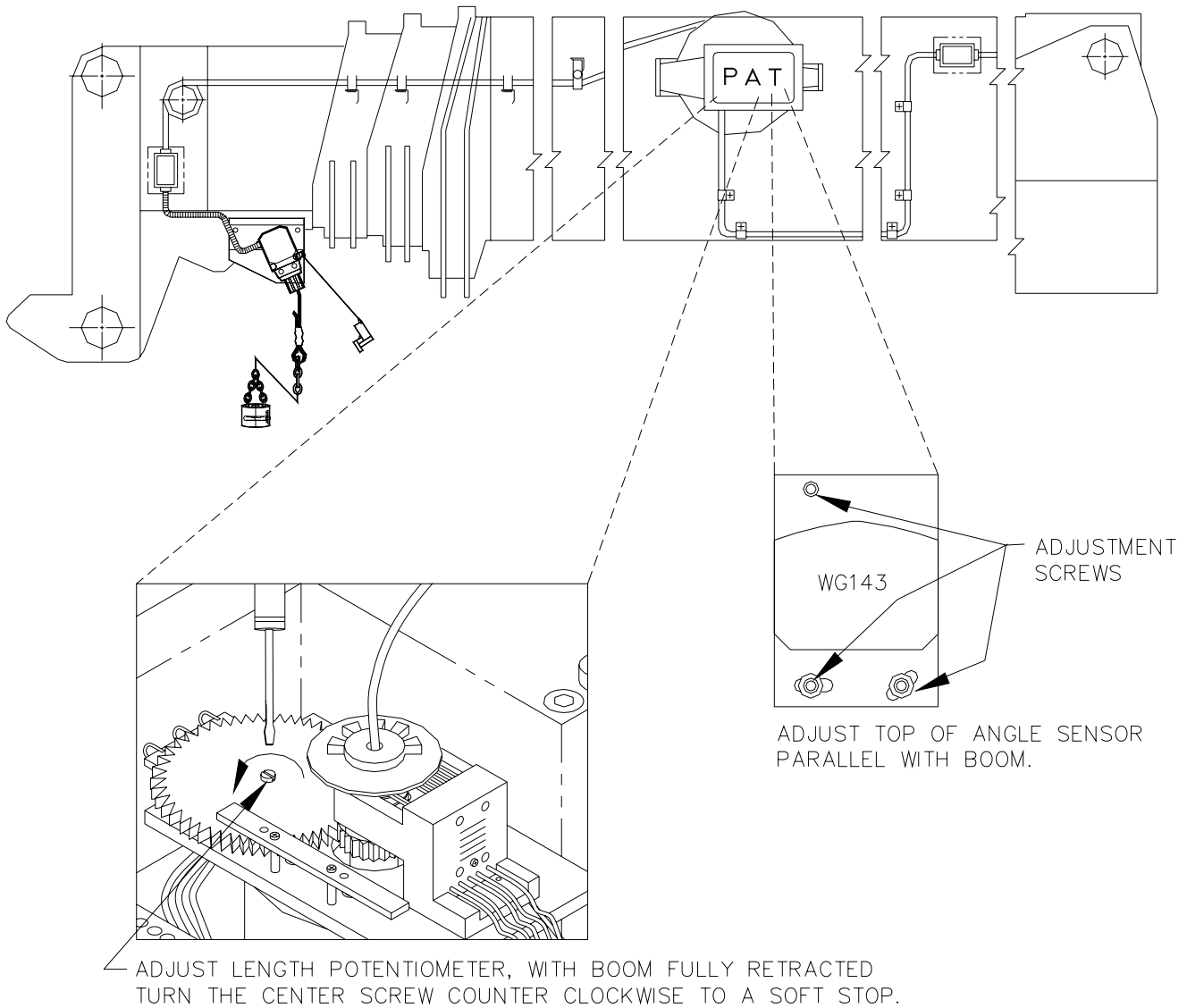

14.5 Cable Reel Length Cable Replacement Procedure

Replace length cable using the following procedure:

Refer to system electrical wiring diagram and cable reel - parts list

1. Cut old cable at cable drum.
2. Disconnect damaged length cable from junction box at the boom nose.
3. Open cable reel cover and disconnect wiring from terminal block. Pull 7 conductor cable out of strain relief. Note: Mark wires to make connection simpler after cable installation.
4. Remove cable reel from mounting brackets.
5. Remove damaged length cable, which is mounted to the slip rings in the cable reel, from slip ring terminal.
6. On the backside of the cable reel, open the strain relief attached to the axle in the center of the drum. Pull existing length cable out of the cable reel.
7. Pull new length cable through the hole, pipe and strain relief and push it through the axle of the reeling drum. Tighten new strain relief to ensure sealing.
8. Reconnect the length cable to the slip ring.
9. Remount cable reel to the boom.
10. Turn reeling drum clockwise to spool the new cable neatly onto the drum.
11. Set pre-load on cable reel by turning the drum counter-clockwise 5 to 8 turns.
12. Run the new length cable through the cable guides and wrap the length cable around the boom tip anchor pin (4 or 5 wraps) and secure with tie wraps. Leave enough length cable to connect into the boom tip junction box.
13. Connect the length cable into the boom tip junction box.
14. Reset length potentiometer in length angle transducer (screw is located in center of white gear); with boom fully retracted, turn potentiometer carefully counter-clockwise until it stops. Recheck length and angle display. Refer to Cable Reel LWG308/0001 Adjustment Procedure.

15 TROUBLESHOOTING MOISTURE

The PAT DS 160 LMI contains electronic components in various locations, such as central unit, sensors, junction boxes etc. These internal components cannot be designed to withstand exposure to moisture over a longer period of time. For this reason, the housings of the components are water protected according to IP 65. If you find water or moisture inside any of the housings, the source for the water ingress has to be detected and corrected to ensure proper operation.

There are two major possibilities for the occurrence of excessive moisture inside an enclosure:

- 1) Water ingress
- 2) Condensation

This outline gives instructions for detecting the cause for excessive moisture by using simple troubleshooting methods and how to prevent the moisture ingress from happening again.

15.1.1 Water Ingress

There are 6 possibilities for water to enter an enclosure:

- 1) Spray Cleaning
- 2) Missing / Loose Screws
- 3) Bent Lid
- 4) Defective Gasket
- 5) Loose Strain Relieves
- 6) Water Entry Through External Cabling

It is possible to find out the source of water ingress by going through the following steps and ruling out one possibility after the other until the cause is identified:

1) Spray Cleaning

The enclosures used for the PAT DS 160 system are water protected to IP 65. This means protection against the environment, such as rain. However, through the use of spray cleaner at short distances, it is possible to force water through the gasket or strain relieves. For this reason, avoid spraying any components from short distances with spray cleaners. Convey this fact to any member of a maintenance crew.

2) Missing / Loose Screws

All screws have to be present and to be equally tight to ensure water protection of the enclosure. If there are screws missing, replace them. If no screw is missing, check the tightness. If any were loose, then open all screws and then re-tighten them equally.

3) Bent Lid

An enclosure will only seal correctly if the lid is not bent. To check this, loosen all screws of the lid, take the lid off the box and visually inspect it for deflection. If the lid is bent or damaged, it needs to be replaced. Try to determine what has caused the lid to be bent and eliminate the reason for that. Order a new lid through your PAT representative.

4) Defective Gasket

The gasket underneath the lid seals the unit. The gasket needs to be in good condition in order to seal correctly. If the gasket is torn, brittle or severely bent, it needs to be replaced. Order a new gasket through your PAT representative.

5) Loose Strain Relieves

The strain relieves allow cabling to enter the box without allowing water to enter it. The strain relieves have to be correctly tightened in order to do this. Check the tightness by taking the external cable into one hand and carefully trying to turn it. If the internal wires turn with the outer cable, the strain relief is loose. Get a new grommet (insert) through your PAT representative and replace the existing one with the new one. Tighten the strain relief correctly. Note: Whenever a strain relief is opened, i.e. to replace a cable, a new grommet needs to be used. Never re-use any grommet or the strain relief will not seal properly!

6) Water Entry Through External Cabling

Even with a tight strain relief, water may still enter the box through the inside of the cable. In this case, you have to find out why and where water enters the cable. Look for damages to the cable itself and inspect the opposite side of the cable. In example, if the cable comes from a connector that is full of water, the water will run through the inside of the cable and fill up the central unit, too.

15.1.2 Condensation

In a climate with high humidity and rapidly changing temperatures, condensation can happen inside any enclosure, usually the larger the volume of the box, the more likely. In this case, water drops build up on the inner components when humid air is trapped inside the box. With condensation, water tightness is not a problem – the box is sealed just fine, which is what prevents the trapped air from exiting the box. There are two ways to deal with condensation:

1. If the volume is very small, a desiccant bag might be able to soak up the air's humidity.
2. If the effect is more severe, the only way to get rid of this effect is then to give the box the ability to breath without sacrificing its water tightness. Contact your PAT representative for breathing elements to than can be added to the box and will help to reduce the effects of humid climates.

16 SENSOR THEORY

The system sensors provide a 4 to 20mA output; however, due to a fixed resistor circuit in the central unit, the input signal can be measured using ammeter (current) or voltmeter (voltage). The input signal operating window is 4 to 20mA, measured in series at the analog input terminal OR 1.0 to 4.9V, measured in parallel between the analog input and ground (GND) terminals. At 4mA the voltage is 1.0V and at 20mA the voltage is 4.9V. When troubleshooting this system, a current or voltage needs to be measured to determine the status or condition of the sensor.

16.1 THEORY 1. OPERATION OF PISTON SIDE LOAD SENSOR

Measuring current:

The ammeter (A) is used to measure current at the piston side input signal. Remove the wire from X1:32 terminal in the central unit and measure the current with the ammeter in series. The measurement should be between 4..20mA.

Measuring voltage:

The voltmeter (V) is used to measure voltage between pins X1:32 (piston side signal) and X1:36 (gnd) on the main board (024-050-300-030). The conversion of 4mA to the voltage of 1.0V is due to the resistor circuit on the main board.

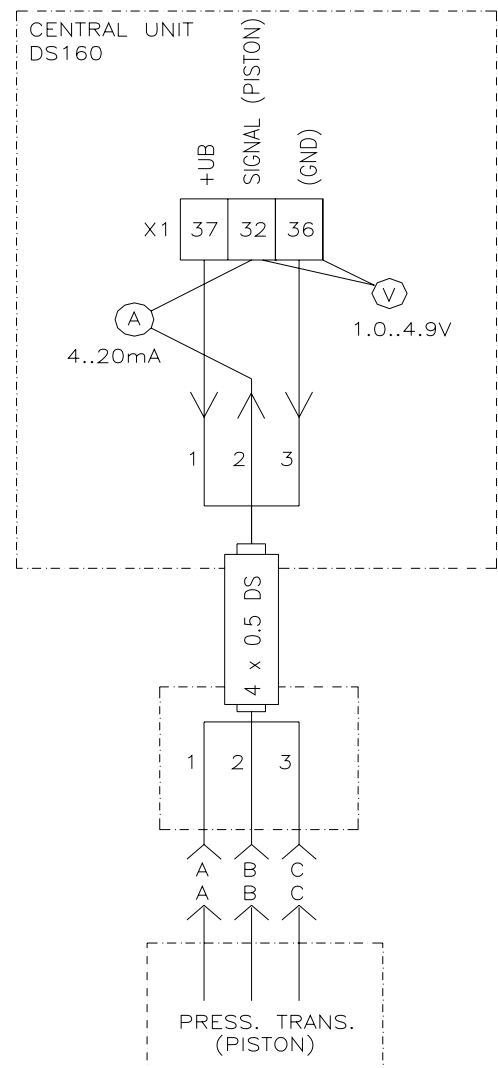
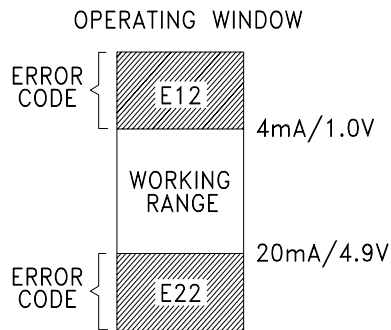

16.2 THEORY 2. OPERATION OF ROD SIDE LOAD SENSOR

Measuring current:

The ammeter (A) is used to measure current at the piston side input signal. Remove the wire from X1:33 terminal in the central unit and measure the current with the ammeter in series. The measurement should be between 4..20mA.

Measuring voltage:

The voltmeter (V) is used to measure voltage between pins X1:33 (rod side signal) and X1:36 (gnd) on the main board (024-050-300-030). The conversion of 4mA to the voltage of 1.0V is due to the resistor circuit on the main board.

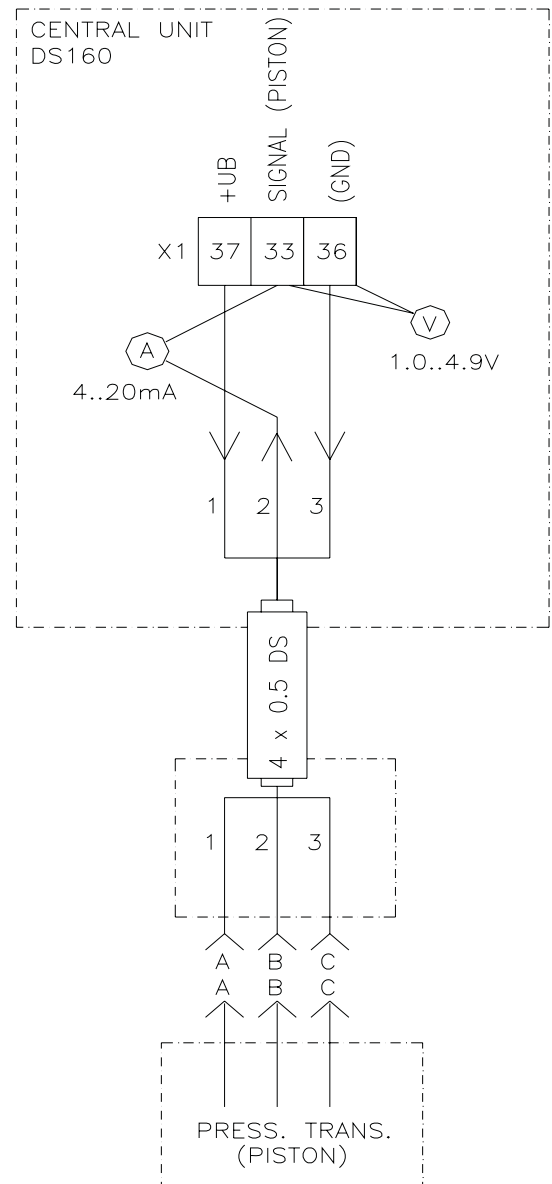
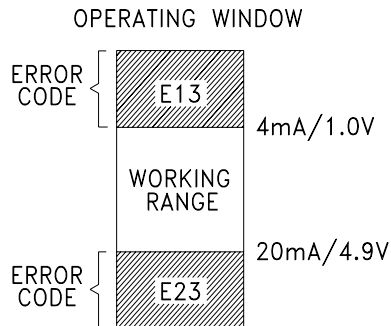

16.3 THEORY 3. OPERATION OF BOOM LENGTH SENSOR

Measuring current:

The ammeter (A) is used to measure current at the length input signal. Remove the wire from X1:34 terminal in the central unit and measure the current with the ammeter in series. The measurement should be between 4..20mA.

Measuring voltage:

The voltmeter (V) is used to measure voltage between pins X1:34 (length signal) and X1:39 (gnd) on the main board (024-050-300-030). The conversion of 4mA to the voltage of 1.0V is due to the resistor circuit on the main board.

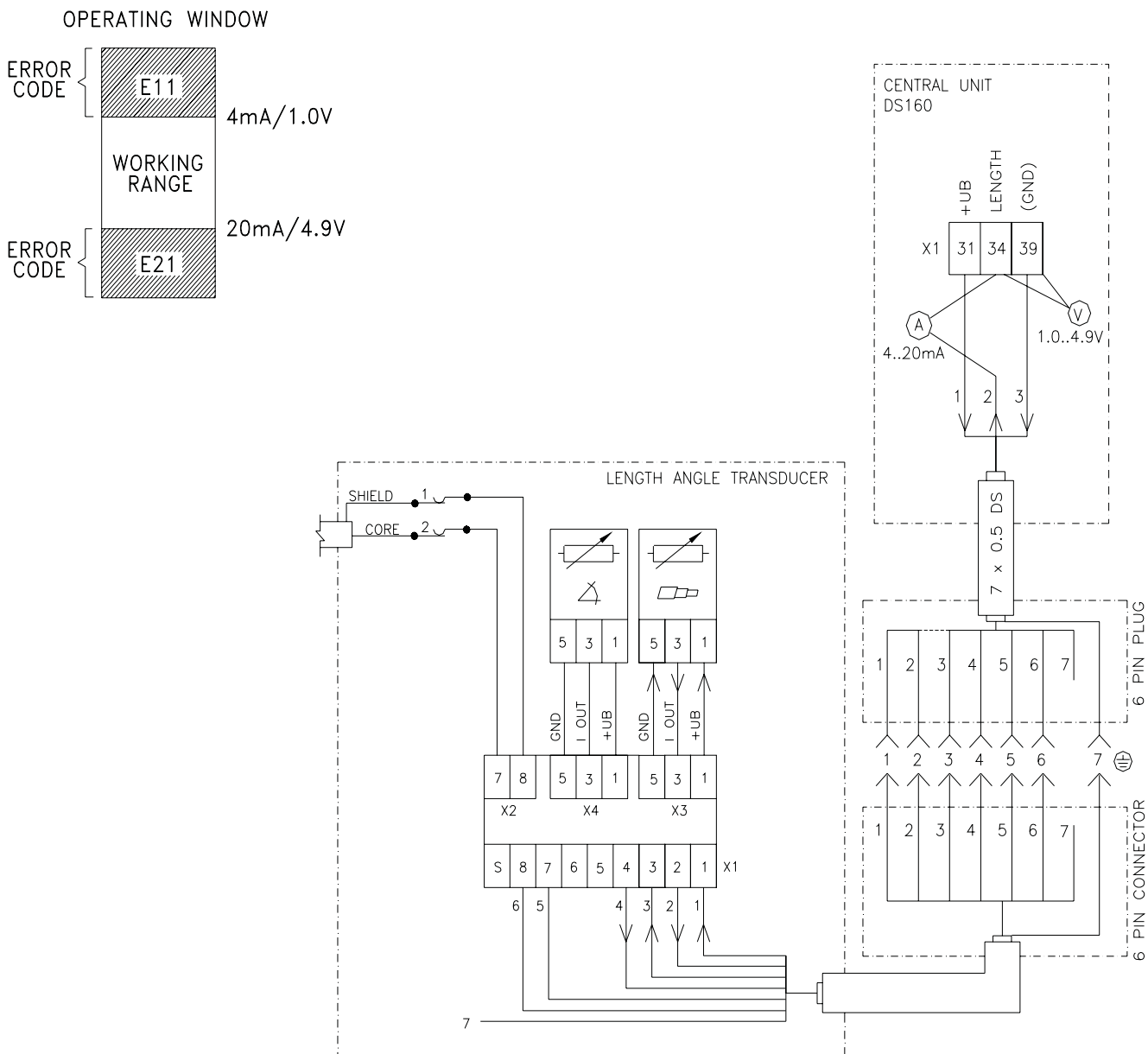

16.4 THEORY 4. OPERATION OF ANGLE SENSOR

Measuring current:

The ammeter (A) is used to measure current at the length input signal. Remove the wire from X1:35 terminal in the central unit and measure the current with the ammeter in series. The measurement should be between 4..20mA.

Measuring voltage:

The voltmeter (V) is used to measure voltage between pins X1:35 (angle signal) and X1:39 (gnd) on the main board (024-050-300-030). The conversion of 4mA to the voltage of 1.0V is due to the resistor circuit on the main board.

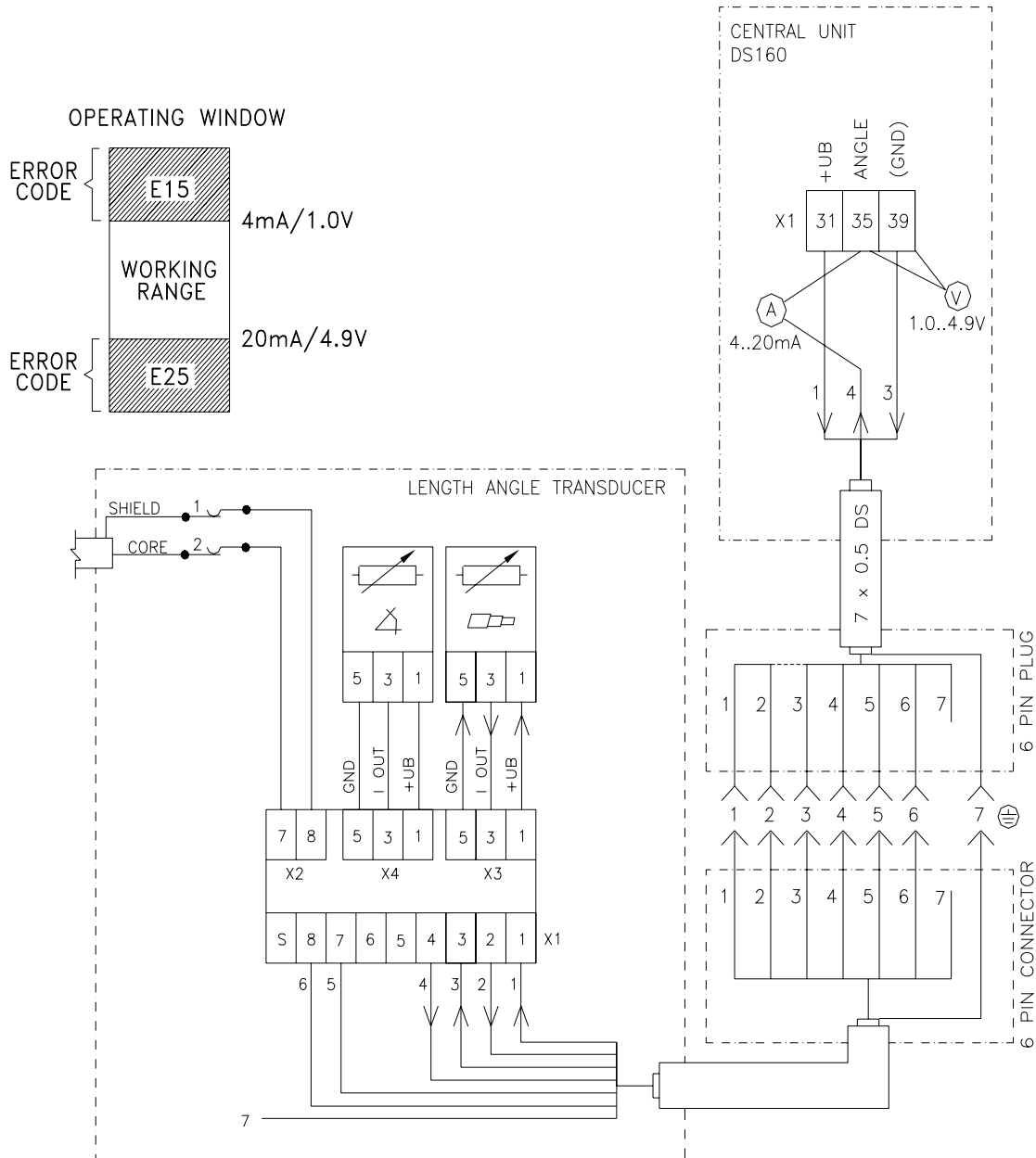

17 DS50C TO DS160 UPGRADE INSTALLATION

The following procedure is an installation guide for the DS160 system when upgrading from a DS50C system. The console and central unit are new installations. The cable reel internal components will be replaced with 4.20mA length and angle sensors. The new 4.20mA pressure transducer and adaptors will replace the existing passive pressure transducers.

031-300-101-552

KIT, DS160 BOOM UPGRADE DS50 TO LWG308

| ITEM | PART NUMBER | QTY | DESCRIPTION |
|------|-----------------|-----|---|
| 1 | 064-143-060-005 | 1.0 | SENSOR, ANGLE WG143/5 90 DEG.W/MTG. FOR LWG308/1/2 4.20mA |
| 2 | 000-205-020-616 | 3.0 | SCREW, 6mm X 16mm SOCKET CAP |
| 3 | 000-207-020-064 | 3.0 | WASHER, FLAT 6mm S.SDIN 9021-ST-A2 |
| 4 | 068-000-300-018 | 1.0 | SENSOR, LENGTH POT. LPE0018CURRENT AMP OUTPUT 4..20mA |
| 5 | 092-000-060-202 | 1.0 | CABLE, MODULAR LENGTH & ANGLESENSOR 3p 32cm |
| 6 | 068-000-300-060 | 1.0 | BOARD, TERMINAL W/EMC FILTERSFOR LG/LWG308 W/CURR. LOOP OUT |
| 7 | 000-205-370-306 | 2.0 | SCREW, 3mm x 6mm PH. PH. |
| 8 | 000-212-010-325 | 4.0 | HARDWARE, STANDOFF 3mm x 25 MF5mm HEX |
| 9 | 002-060-100-301 | 4.0 | NUT, 3MM HEX |
| 10 | 000-208-030-030 | 4.0 | WASHER, 3mm CONCAVE BELLVILLEFOR ELECTRONIC BOARDS |
| 11 | 031-300-060-414 | 1.0 | CABLE ASSY, 7COND 18' 7 PINPLUG, FOR CABLE REEL ASSEMBLY |
| 12 | 123-429-907-910 | 5.0 | WIRING ACCY, CRIMP FERRULE, 20AWG, INSULATED, WHITE |
| 13 | 123-429-907-890 | 3.0 | WIRING ACCY, CRIMP FERRULE, 14AWG, INSULATED, BLUE |
| 14 | 031-300-050-255 | 1.0 | STRAIN RELIEF, PG11 GREEN EMI/RFI 8-10.5mm |
| 15 | 000-214-261-311 | 1.0 | STRAIN RELIEF, PG13.5/PG11REDUCER |
| 16 | 000-214-340-013 | 1.0 | STRAIN RELIEF, PG13.5 HOLEPLUG |

031-300-101-579

KIT, DS160 CU, CONSOLE, PT, & SOFTWARE, US BASE KIT

| ITEM | PART NUMBER | QTY | DESCRIPTION |
|------|-----------------|-----|---|
| 1 | 031-300-060-645 | 1.0 | CENTRAL UNIT ASSY, DS160/0003RETRO W/90° CONSL CBL & H DAVS |
| 2 | 031-300-060-362 | 1.0 | CONSOLE ASSY, DS160 W/RAMMOUNT |
| 3 | 031-300-050-589 | 1.0 | CONSOLE ACCY, PCS30.5 MOUNTING1" BALL W/2.437" DIA PLATE |
| 4 | 031-300-050-485 | 6.0 | SCREW, #10-24 X 5/8 PH. PH. SSMACHINE SCREW |
| 5 | 031-300-050-489 | 6.0 | NUT, #10-24 LOCK NYLON INSERT |
| 6 | 000-207-010-053 | 6.0 | WASHER, FLAT #10 |
| 7 | 000-209-140-016 | 2.0 | SENSOR ACCY, CUTTING RING DKA16 (PRESSURE TRANSDUCERS) |
| 8 | 031-300-060-452 | 2.0 | SENSOR, PRES.TRAN.DAVS300/34014.20mA,300 bar,M12,9/16-18 |
| 9 | 031-300-050-689 | 2.0 | HYDR, ADAPTER, 9/16-18 UNF-2B;M16 X 1.5 |
| 10 | 021-441-110-811 | 1.0 | STRAIN RELIEF, PG11 6mm, GREEN+WHITE INSERT |
| 11 | 031-300-050-255 | 1.0 | STRAIN RELIEF, PG11 GREEN EMI/RFI 8-10.5mm |
| 12 | 031-300-190-139 | 1.0 | MANUAL, OPER, DS160 |
| 13 | 031-300-190-142 | 1.0 | MANUAL, SERV, DS160 |

17.1 Console Mounting

The console has a mount that allows the console to be swiveled into any direction and to be mounted in a variety of locations and on nearly any surface. Choose a location that is in line of site of the sensor and within reach of the operator. Securely attach the two RAM mount bases onto a solid surface for the left and right side operation. The console cable may not fit through goose neck/conduit as existing wiring; therefore, run the console cable to the outside of the conduit and insure there no interference. Refer to 13.6 Console DS160/0005 / Parts List.

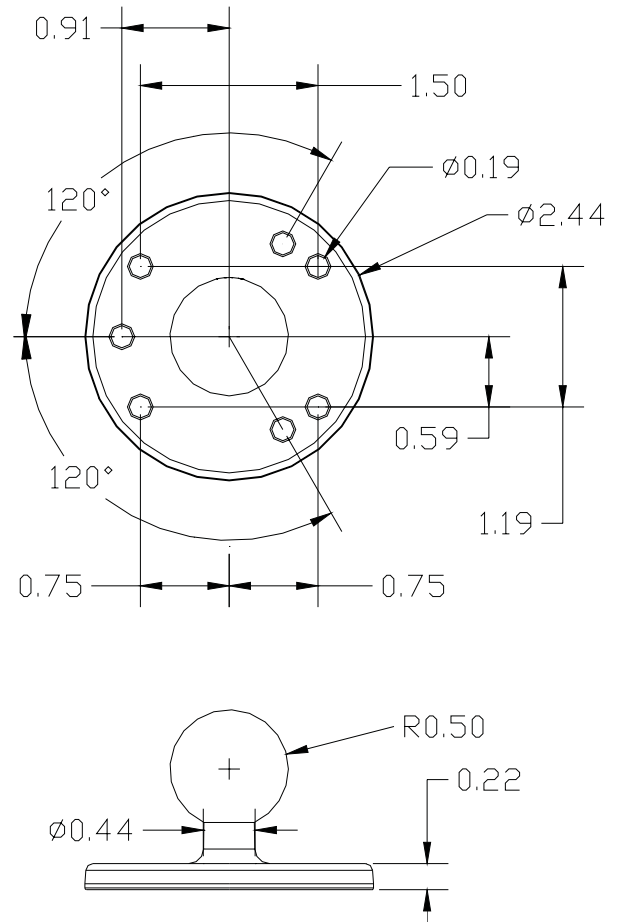

17.2 Central Unit Mounting

Mount the central unit in covered but accessible location. You will need to remove the cover and access the EPROM's and main board. The central is supplied with 4 mounting weld tabs or can be bolted in place. Refer to 13.4 Central Unit Main Board Termination and Breakdown / Parts List for CU dimensions and 13.3 System Wiring Diagram.

17.3 Software

The existing software for the DS50C must be sent to Hirschmann Electronics. The data on the EPROM's will be reconfigured for the DS160. **Use the EPROM module supplied with the DS160.**

17.4 Pressure Transducer Replacement

Use the 031-300-050-689 hydraulic adapter (9/16-18 UNF-2B;M16 X 1.56-18 UNF-2B) to replace the existing passive pressure transducers with the new 4.20mA pressure transducer. Refer to 13.8 Pressure Transducer (DAVS300 / 3401)

17.5 DS160 COMPONENT INSTALLATION PROCEDURE

1. Retract the boom fully. Refer to the manufacturer's operator's manual and familiarize yourself with its operation and the LMI bypass. Lower the boom to gain access to the DS 50 system.
2. Switch crane power off.
3. Remove the cable reel cover face by loosening all 10 screws. The screws should remain secured in the lid.
4. Remove all connections located at X-1, X-2, X-7 and X-8.
5. Remove the two screws that secure the EPROM module and remove it.

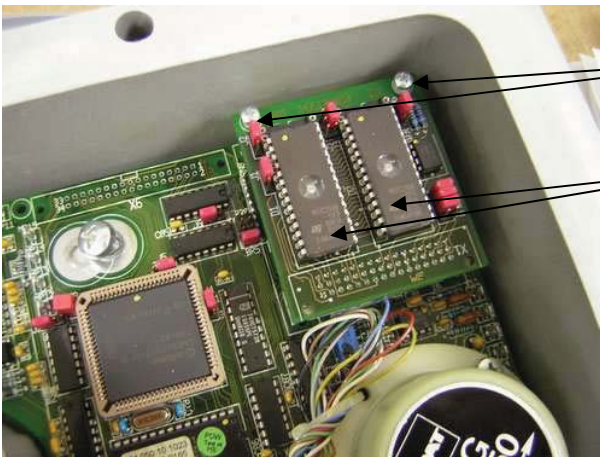

(2) screws that secure the EPROM module

The EPROM is a sensitive device and can be damaged if not handled properly. To prevent damage, discharge any static electricity in your body before handling the EPROM's. This can be accomplished by touching a grounded surface.

WARNING: Do not re-use the DS50 EPROM module in the cable reel, as damage may occur to the DS160 system.

6. Remove the two screws that secure the gear wheel guardrail.

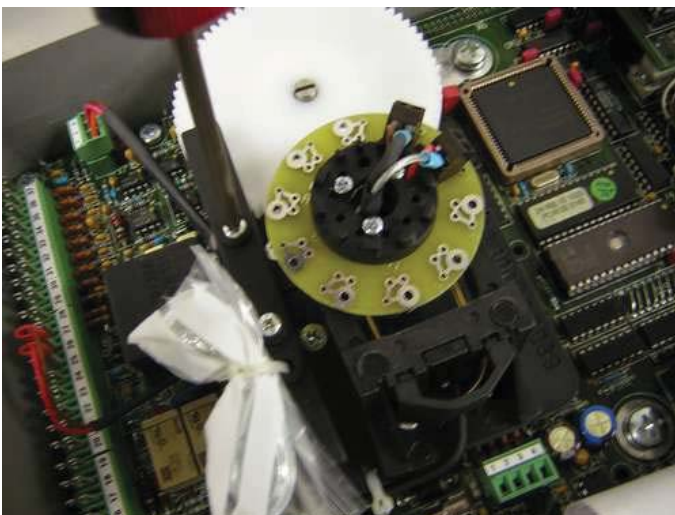

7. Remove the (4) screws holding the slip ring/length sensor mounting plates and remove the slip ring and length sensor assemblies.

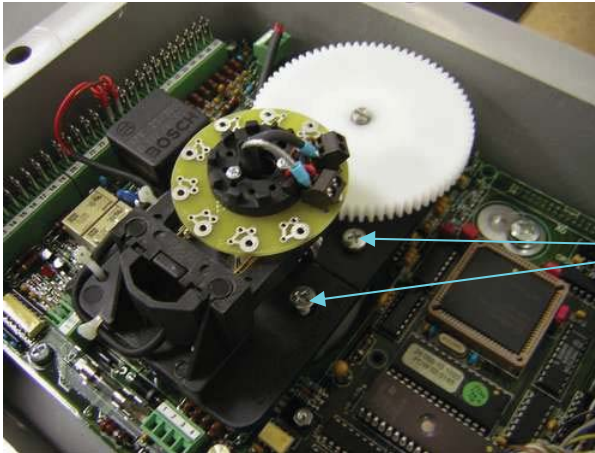

Mounting plate screws

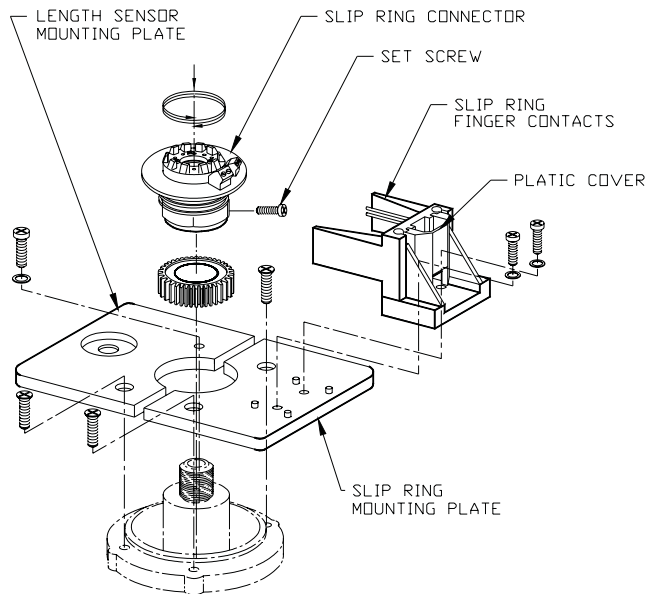

8. Replace the length sensor potentiometer (068-000-300-018) with the pot + board and JST wire assembly provided. The length pot is keyed not to turn as shown below and should be installed in the plastic mounting plate.

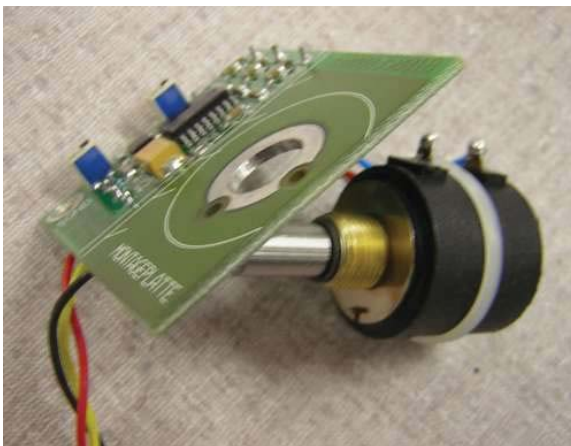

9. Locate the (8) Philips screws that secure the main board to the cable reel housing and carefully remove the screws.



10. Carefully remove the main board.

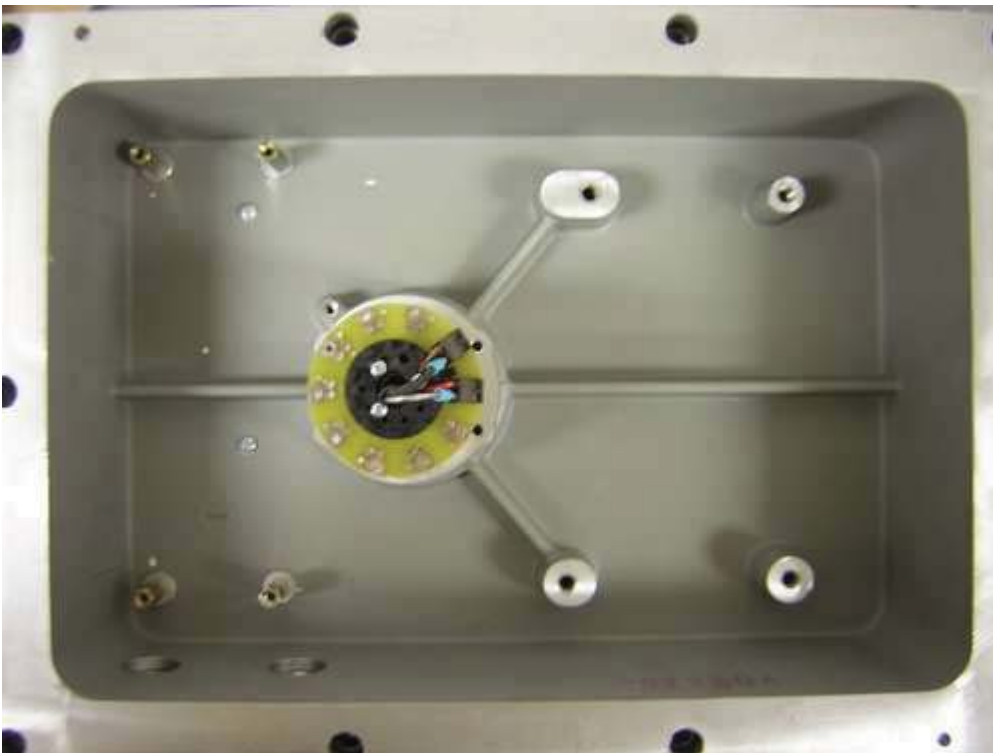

11. Remove (2) screws in the bottom of the cable reel as shown and install (2) M3 x 25mm standoffs as seen in the two photographs below.

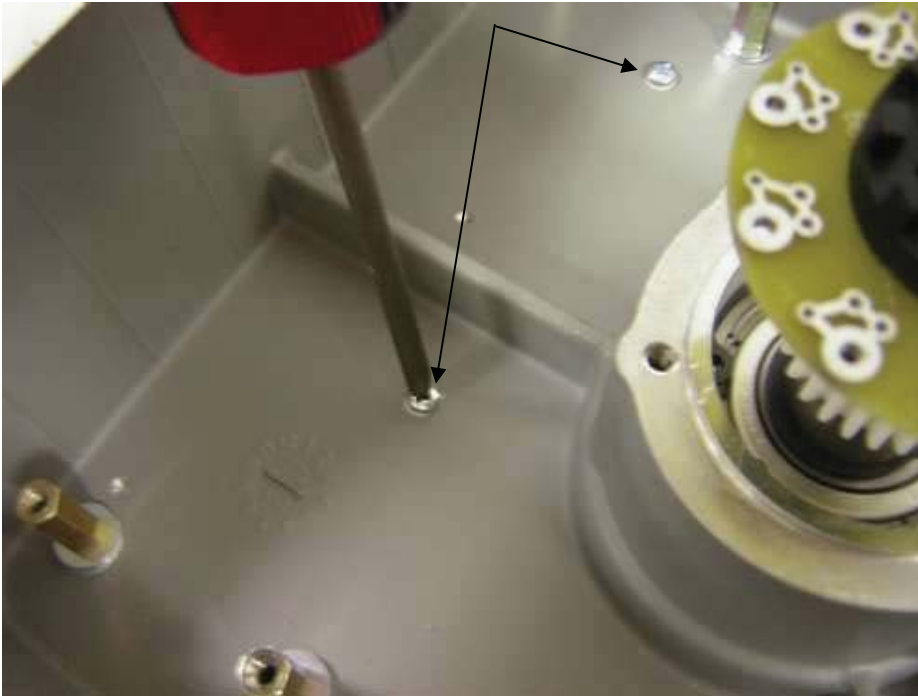

12. Reinstall the slip ring/length sensor and mounting plates (previously removed in step 7) into the cable reel and tighten the (4) screws.
13. Install angle sensor (064-143-060-005) into the cable reel using the (3) M6x16mm screws and washers provided in the kit.



14. Install the gear wheel and guard rail. Tie wrap the wires as shown to prevent wires from getting wrapped in the gear wheels or slip ring.

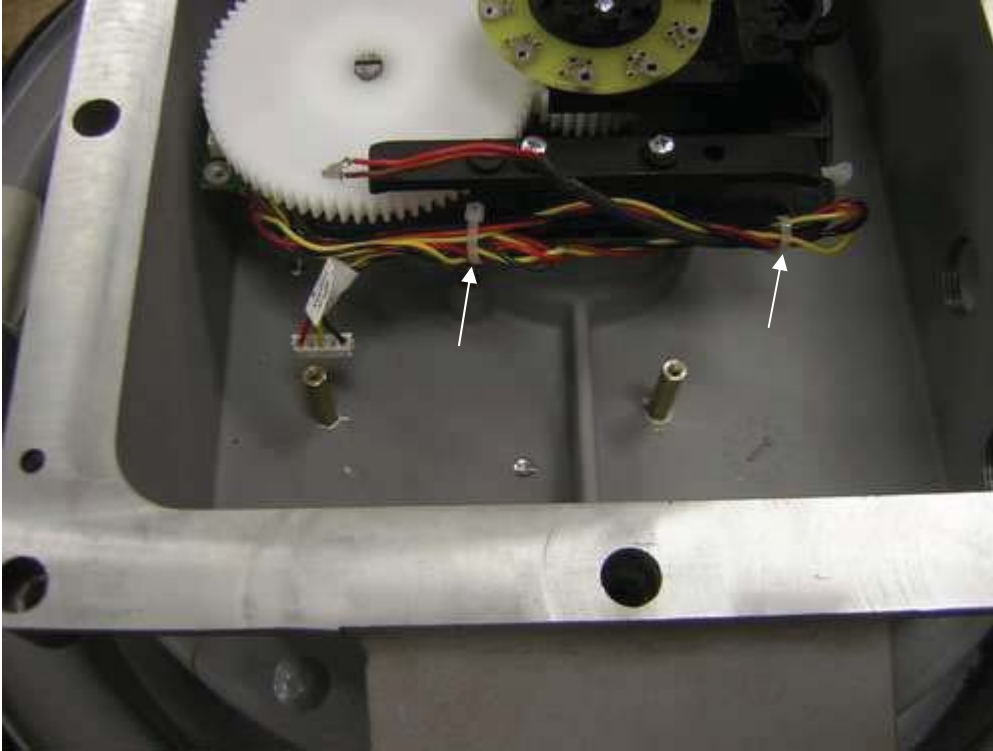

15. Install (2) M3 x 25mm standoffs in the 068-000-300-060 (labeled on board as 68 000 30 0060) using (2) 3mm hex nuts and (2) 3mm washers as shown below. These (2) standoffs serve as legs to support the board and are not attached to the reel.

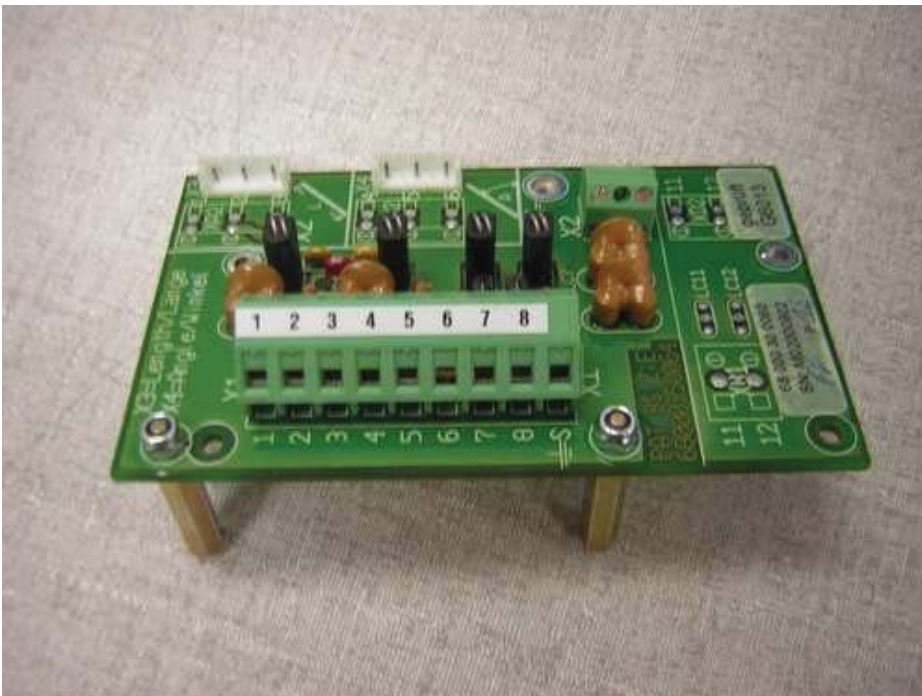

16. Install the board into the cable reel using (2) 3mm x 6mm screws and (2) 3mm washers. Connect the length JST connector to X3 and the angle sensor connector to X4. Strip the red and brown wires and connect red to X2:7 and brown to X2:8.

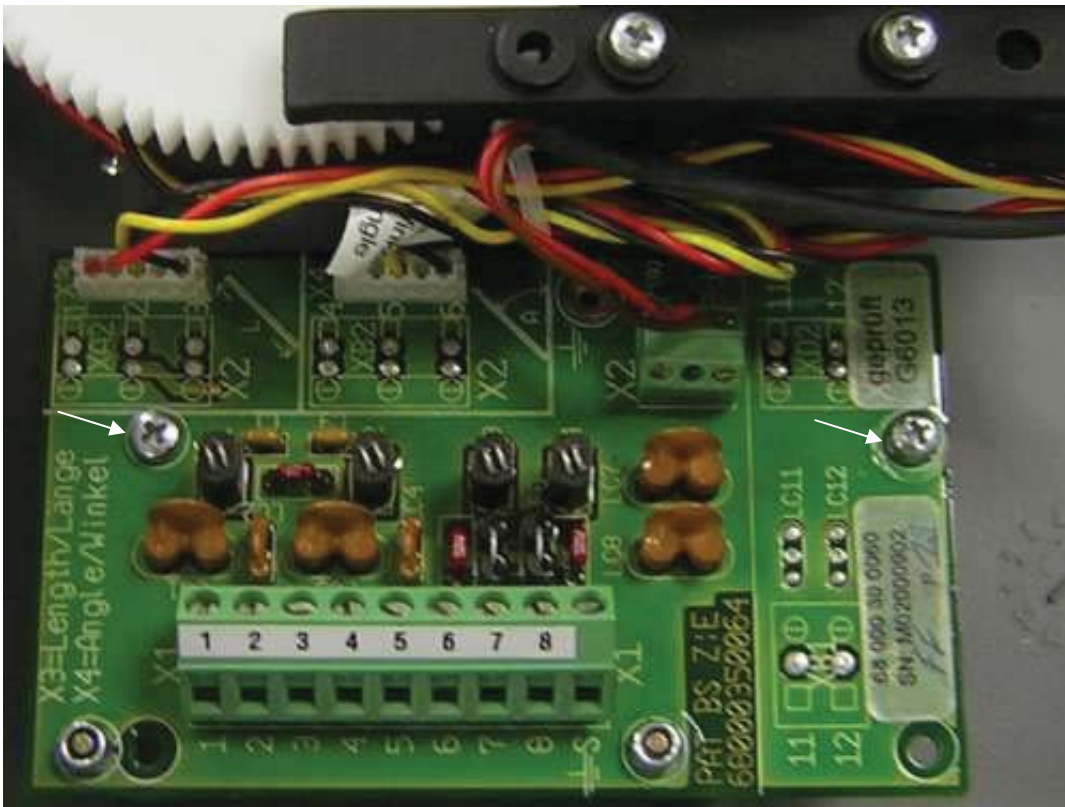

17. Connect cable assembly 031-300-060-414 (7 conductor x 18' long) to the cable assembly extending from the central unit. Route the cable up the boom to the cable reel. Allow a minimum 12" length to extend into the cable reel, then cutoff the excess cable. Strip the outer cable jacket, cut the outer shield, and install the cable into the reel through the PG11 green colored strain relief per the diagram below. For the wiring diagram to the board shown above, refer to the system wiring diagram on page 27 in this manual.

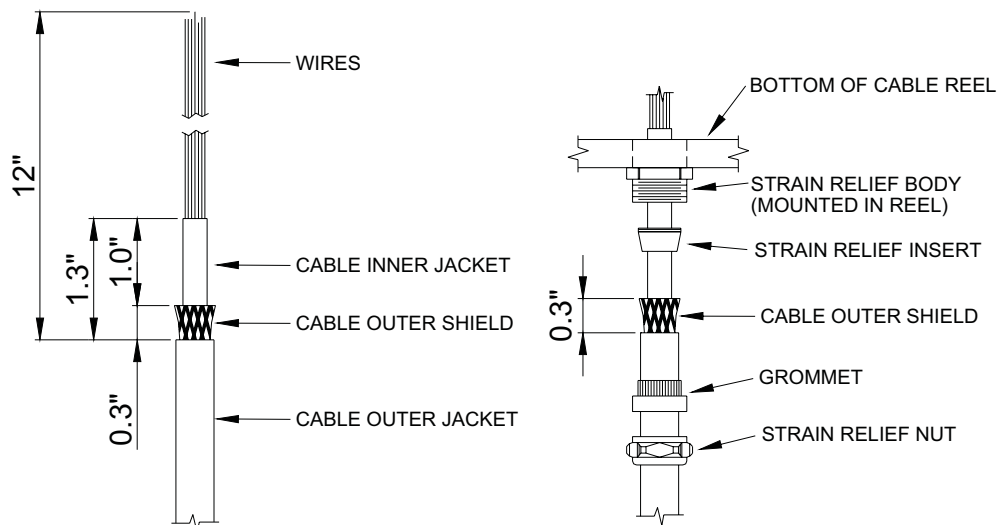

18. Install the PG13.5 hole plug in the other cable entry hole in the cable reel.
19. Adjust length and angle sensor.
 - a. Reset length potentiometer in length angle transducer (screw is located in center of white gear); with boom fully retracted, turn potentiometer carefully counter-clockwise until it stops.
 - b. Check the angle. Use a calibrated inclinometer to measure the main boom angle and compare with displayed angle on console. Adjust the angle sensor if necessary. Loosen the mounting screws holding the angle sensor in the reel. The plate is slotted which will allow the sensor to be adjusted in the reel until the displayed angle is equal to or 2 degrees less than the actual (measured) boom angle.
 - c. Verify A2B operation. Refer to Operator's Manual 031-300-190-139.

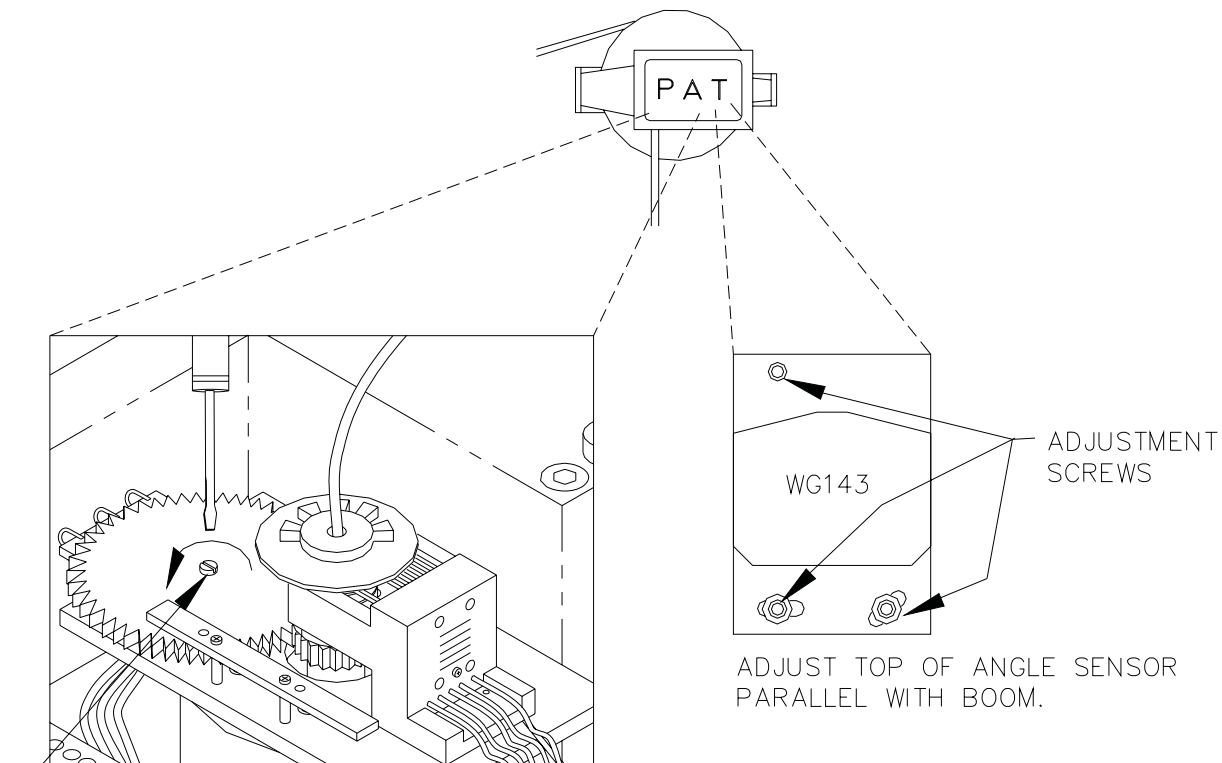

- ADJUST LENGTH POTENTIOMETER, WITH BOOM FULLY RETRACTED
TURN THE CENTER SCREW COUNTER CLOCKWISE TO A SOFT STOP.
20. Replace cable reel cover and tight the cover bolt in a crossing pattern to 5.5N-m or 7ft-lbs.
21. Proceed to **Section 14.3** (page 35) for the **Calibration of Sensors Procedure**.

17.6 LMI SYSTEM TEST PROCEDURE

WARNING
Do not operate the crane outside the permissible operating range for the type of crane / capacity chart being tested.

- 1) Most crane manufacturer calibrate the cranes with the jib removed it is recommended that this is done to carry out the following test. However on some cranes this might not be the case, if in doubt contact the manufacturer.
- 2) For calibration verification a test load is to be employed for each of the following configuration;

NOTE: For safety reasons first measure the allowable radius for the load being used have a spotter to ensure the system stops the functions at or before this point.

- 3) Maximum Boom Length and Middle Radius (select a load that will lock out the functions about the middle of the load chart in the long boom length step)
- 4) The following test should be recorded signed and dated. A copy of this test sheet should be available at all times.
- 5) Test load to be applied by suspending known weights accurate to +/-1%. Weights of all additional equipment such as blocks, slings, sensors, etc., are included in the test load. The total load is to be known to an accuracy of +/-1%.

With extended boom and the load suspended, move the load smoothly from the short radius to overload lock out, measure and record radius, calculate cut off % see section 6. Ensure the appropriate functions are disabled.

- 6) Computations:
 For each radius measured in the above tests refer to the applicable load rating chart and determine the rated load. At radii intermediate to those on the load chart, rated load shall be determined by linear interpolation unless otherwise specified by the crane manufacturer.

The system accuracy is to be determined from the following formula:

$$\frac{\text{TEST LOAD}}{\text{RATED LOAD at cut off radius/angle}} \times 100 = \% \text{ OF RATED LOAD}$$

- 7) The actual load which activates the overload lock out is not less than 90% of the rated load nor more than 100% of the rated load for the corresponding actual load radius or boom angle.

Note: This is a general standard and variations may exist, if in doubt contact the crane manufacturer.

CALIBRATION TEST

CRANE S/N:

| Op/ Mode | Parts of Line | Main / B Length | Main / B Angle | Jib / Ext Length | Jib Offset | Actual Load | Indicated Load | Actual Radius | Indicated Radius | Cutoff % |
|----------|---------------|-----------------|----------------|------------------|------------|-------------|----------------|---------------|------------------|----------|
| | | | | | | | | | | |
| | | | | | | | | | | |
| | | | | | | | | | | |
| | | | | | | | | | | |



www.skyazul.com

SkyAzul, Inc.

200 W. Main Street, Suite, 2A
Middletown, MD 21769
Phone 301-371-6126
Fax 301-371-0029
info@skyazul.com

