

CONSERVER II

CHEMICAL SANTIZING
DISHWASHER

SERVICE MANUAL

INCLUDES:

- | | |
|----------------------------|-------------------------|
| -Warranty Policy | -Specifications |
| -Installation Requirements | -Maintenance and Care |
| -Operating Instructions | -Illustrated Parts List |
| -Description of Components | -Electrical Diagrams |



WORLD HEADQUARTERS & MANUFACTURING OPERATIONS
Highway 25E, P.O. Box 1060
Barbourville, KY 40906
888/800-JMSC
FAX 606/532-9196

MANUFACTURERS WARRANTY ONE YEAR LIMITED PARTS & LABOR WARRANTY

ALL NEW JACKSON DISHWASHERS ARE WARRANTED TO THE ORIGINAL PURCHASER TO BE FREE FROM DEFECTS IN MATERIAL OR WORKMANSHIP, UNDER NORMAL USE AND OPERATION FOR A PERIOD OF (1) ONE YEAR FROM THE DATE OF PURCHASE, BUT IN NO EVENT TO EXCEED (18) EIGHTEEN MONTHS FROM THE DATE OF SHIPMENT FROM THE FACTORY.

Jackson MSC agrees under this warranty to repair or replace, at its discretion, any original part which fails under normal use due to faulty material or workmanship during the warranty period, providing the equipment has been unaltered, and has been properly installed, maintained and operated in accordance with the applicable factory instruction manual furnished with the machine and the failure is reported to the authorized service agency within the warranty period. This includes the use of factory specified genuine replacement parts, purchased directly from a Jackson authorized parts distributor or service agency. Use of generic replacement parts may create a hazard and void warranty certification.

The labor to repair or replace such failed part will be paid by Jackson MSC, within the continental United States, Hawaii and Canada, during the warranty period provided a Jackson MSC authorized service agency, or those having prior authorization from the factory, performs the service. Any repair work by persons other than a Jackson MSC authorized service agency is the sole responsibility of the customer. Labor coverage is limited to regular hourly rates, overtime premiums and emergency service charges will not be paid by Jackson MSC.

Accessory components not installed by the factory carry a (1) one year parts warranty only. Accessory components such as table limit switches, pressure regulators, pre rinse units, etc. that are shipped with the unit and installed at the site are included. Labor to repair or replace these components is not covered by Jackson MSC.

This warranty is void if failure is a direct result from shipping, handling, fire, water, accident, misuse, acts of god, attempted repair by unauthorized persons, improper installation, if serial number has been removed or altered, or if unit is used for purpose other than it was originally intended.

TRAVEL LIMITATIONS

Jackson MSC limits warranty travel time to (2) two hours and mileage to (100) one hundred miles. Jackson MSC will not pay for travel time and mileage that exceeds this, or any fees such as those for air or boat travel without prior authorization.

WARRANTY REGISTRATION CARD

The warranty registration card supplied with the machine must be returned to Jackson MSC within 30 days to validate the warranty.

REPLACEMENT PARTS WARRANTY

Jackson replacement parts are warranted for a period of 90 days from the date of installation or 180 days from the date of shipment from the factory, whichever ever occurs first.

PRODUCT CHANGES AND UPDATES

Jackson MSC reserves the right to make changes in design and specification of any equipment as engineering or necessity requires.

THIS IS THE ENTIRE AND ONLY WARRANTY OF JACKSON MSC. JACKSON'S LIABILITY ON ANY CLAIM OF ANY KIND, INCLUDING NEGLIGENCE, WITH RESPECT TO THE GOODS OR SERVICES COVERED HEREUNDER, SHALL IN NO CASE EXCEED THE PRICE OF THE GOODS OR SERVICES OR PART THEREOF WHICH GIVES RISE TO THE CLAIM.

THERE ARE NO WARRANTIES, EXPRESSED OR IMPLIED, INCLUDING FOR FITNESS OR MERCHANTABILITY, THAT ARE NOT SET FORTH HEREIN, OR THAT EXTEND BEYOND THE DURATION HEREOF. UNDER NO CIRCUMSTANCES WILL JACKSON MSC BE LIABLE FOR ANY LOSS OR DAMAGE, DIRECT OR CONSEQUENTIAL, OR FOR THE DAMAGES IN THE NATURE OF PENALTIES, ARISING OUT OF THE USE OR INABILITY TO USE ANY OF ITS PRODUCTS.

ITEMS NOT COVERED

This warranty does not cover adjustments to timer cams or thermostats, cleaning wash arms or strainers, or replacement of wear items such as curtains, squeeze tubes, drain balls, door guides, or gaskets beyond 30 days from installation of unit. Also not covered are conditions caused by the use of incorrect (non commercial) grade detergents, excessive supply water temperature or pressure, or hard water conditions.



INDEX

WARRANTY	
SPECIFICATIONS	3
GENERAL INSTRUCTIONS (Installation)	4
GENERAL INSTRUCTIONS (Operation)	6
GENERAL INSTRUCTIONS (Preventive Maintenance)	8
WASH/RINSE HEAD ASSEMBLY	9
TIMER ADJUSTMENTS	10
TIMER ASSEMBLY, SPANNER WRENCH, TIMERMICRO SWITCH, SIDE VIEW of CAM	11
FUNCTION of SWITCHES, CIRCUIT BREAKER, INDICATOR LIGHTS and CYCLE COUNTER	12
REPLACEMENT of SWITCHES in CONTROL PANEL	13
PERISTALTIC PUMP SANITIZING DISPENSING SYSTEM	14
SANITIZING AGENT INJECTOR	15
WASH/RINSE PUMPASSEMBLY	16
REPLACING SEAL and CERAMIC on WASH/RINSE PUMP	17
DRAIN VALVEASSEMBLY, STRAIGHTTHROUGH MODEL	18
SERVICE INSTRUCTIONS (Incoming Water Solenoid Valve)	19
INSTRUCTIONS for ADJUSTING TENSION of CANTILEVER	20
APPLYING NYLATRON STRIP to CONSERVER DOOR	22
TROUBLE SHOOTING GUIDE	23
PICTORIALS	
BACKSIDEVIEW	25
RIGHTSIDEVIEW	26
LEFTSIDEVIEW	27
INCOMING PLUMBING, VACUUM BREAKER, MERCURY RELAY	28
ANTI-FOAM VALVE	29
ELECTRICAL DRAWINGS	30,31
PARTS LIST	32,33
NOTES	34
PARTS DISTRIBUTORS	INSIDE BACK COVER

SPECIFICATIONS

Operating Capacity		Thermometers		Phase	Approximate
Racks per hour	74	Wash - °F	140	1 (3 wire)	Total Load Amps
(NSF Rated) Dishes per hour	1900	Water Requirements (NSF Rated)		Dimensions	26
Glasses per hour	1900	Inlet Temperature - °F	140	Depth	25"
Operating Cycle		Gal per hour	188	Width	44"
Total Cycle - Sec	90	Flow Pressure PSI	20	Height	67 1/4"
Wash Tank Capacity		Flow GPM	16.5	Standard Table Height	34"
Gallons	4.0	Inlet IPS	3/4"	Maximum Clearance for Dishes	15"
Wash Pump Capacity (2 pumps)		Drain IPS	2"	Racks	
Gal Per Min	55	Available Chlorine during rinse cycle Min. 50 ppm		Dish, 19 3/4 x 19 3/4	Optional
Electrical Rating		Wash Pump Motor		Combination	Optional
CONSERVER	Volts	Horsepower (2)	1	Shipping Weight	
	115			Approx Basic Model	350 lbs.

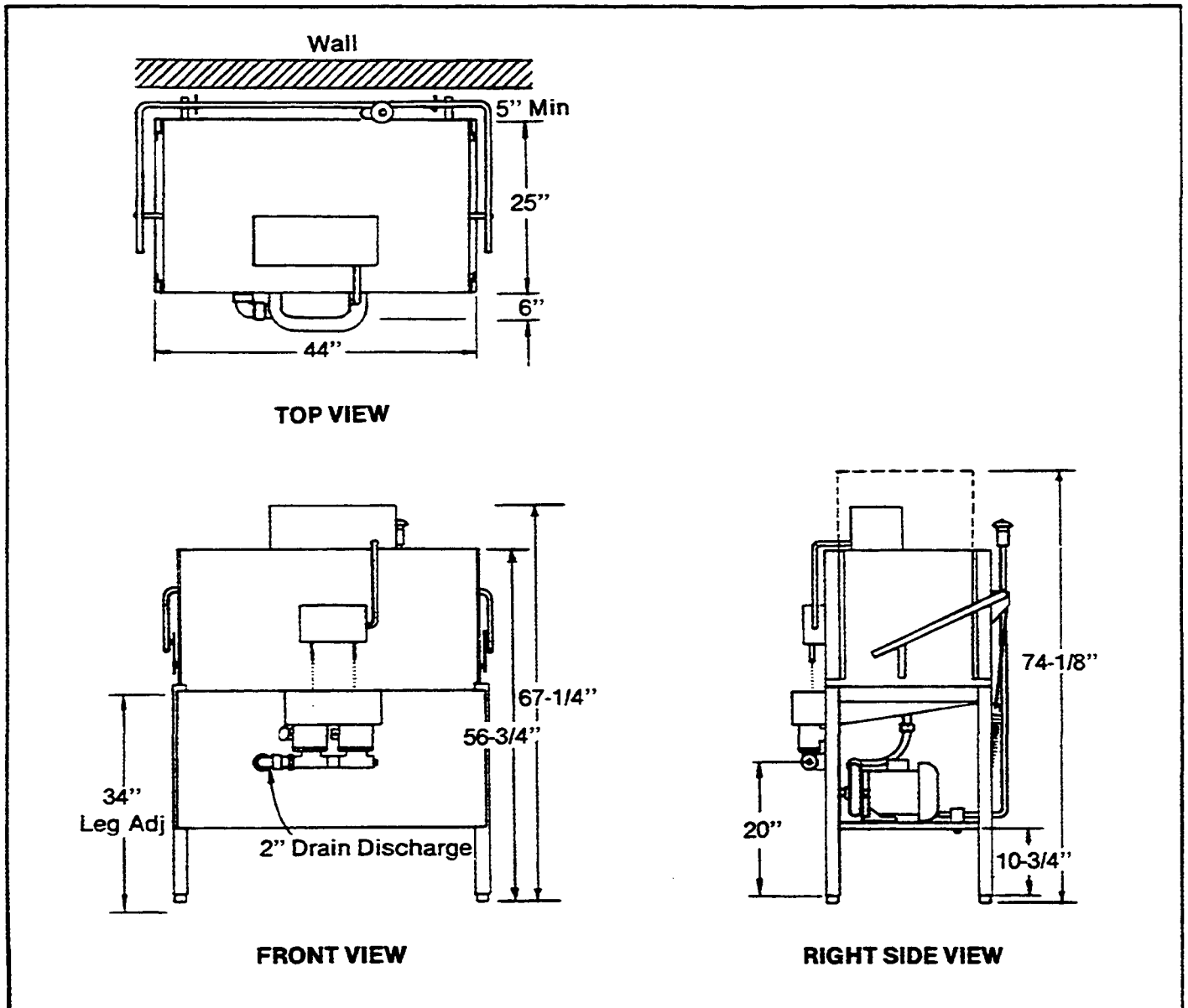

All dimensions and specifications are subject to change without notice.

GENERAL INSTRUCTIONS

(INSTALLATION)

Note: Read the following instructions carefully. Proper installation of your Conservor Dishwasher will ensure proper machine operation.

1. Cut straps holding machine to base of crate, ease machine on to floor and move into place of installation.
2. Connect drain line to bottom of machine (2 IPS female fitting on front of machine) to conform with local and/or national codes. Drain is a gravity feed system from the machine.
 - a. The Conservor is designed to accommodate an external scrap trap if one is shipped with the unit. The scrap trap should be placed beneath the unit with the top opening to the right of the pump and motor mounting shelf so that the top hole of the scrap trap is in line with the drain opening from the machine.
 - b. Direct the drain line from the dishwasher to the top of the trap and plumb accordingly with 2" pipe of the necessary length. Connect a 2" fitting to the back of the scrap trap and plumb to the drain line. The drain line is a gravity feed system from the dishwasher to the scrap trap and also from the scrap trap to the drain line. Scrap trap aids sluggish drains by containing machine water as it drains and letting it drain off slower.
3. Connect incoming $\frac{3}{4}$ " water line with capacity to supply 16.5 gallons per minute with a flow rate of 20 PSI at a temperature of 140°F. This connection is just before the Y-strainer. Connect to conform with local and/or national codes (standards).
 - a. It is recommended that in areas where there is fluctuating water pressure a restrictor valve allowing 8 gallons of water per minute be installed. This will help to provide a steady fill rate. The restrictor should be located down the line from the Y-strainer.
4. Install the proper circuit breaker, wire and conduit size to conform with local and/or national codes. Refer to data plate for electrical codes.
- 5- The electrical connections are made to the terminal block located in the dispenser/control box on the top of the machine. The terminal block is located on the back wall of the box with a grounding lug next to it. Three wires L1, N, and a ground wire should be passed through the hole in the back of the box and connected to the terminal block as marked.
- 6. Do not apply power until step #9.**
7. Turn on water supply to machine; check for any leaks in plumbing and connections.
8. Place the open end of the red tube into a container of detergent; white, into a container of sanitizer; and blue, into a container of rinse additive.
9. To energize electrically, proceed as follows:
 - a. Turn on customer's circuit breaker controlling the machine.
 - b. Check voltage at incoming terminals L1 and N. It should match data plate voltage. Voltage at L1 should be checked to ground to ensure that a high (or wild) leg is **NOT** connected. (Voltage exceeding 150V to ground would indicate a high leg.)
 - c. If voltages are in required range, turn on circuit breaker on the side of the dispenser/control box.
10. To fill the unit with water:
 - a. Located on the right side of the control box is a two-positioned momentary switch. To fill this unit initially with water, push and hold the switch to the top of the unit until the water reaches the-top of the cut out for the drain opening. Release the switch and it will return to the off position.
 - b. After the unit is full of water, check for leaks and see if the solenoid valve opens and closes as the fill switch is turned on and off.
 - c- After checking the plumbing lines for leaks, run the unit through a complete cycle to determine the proper water level. The proper level for the water is the top of the cut out for the drain opening leading from the machine into the drain strainer and stopper. If this level is either not reached or is exceeded, please turn to the timer section of this manual to determine the proper adjustment of the timer that has to be made.

- d. Above each peristaltic pump is a priming switch. After making sure that the feeder tubes to the pumps are in their proper containers, as marked on the pumps, press the switch and hold it until there is a discharge of the fluid into the machine. This is to be done to each pump before the initial operation of the machine. Water must be in wash-rinse tub to prevent discoloration or deterioration of the stainless tub by chemicals.
- e. The dishwasher is now ready to proceed with the washing of dishes in accordance with operating instructions in this manual.

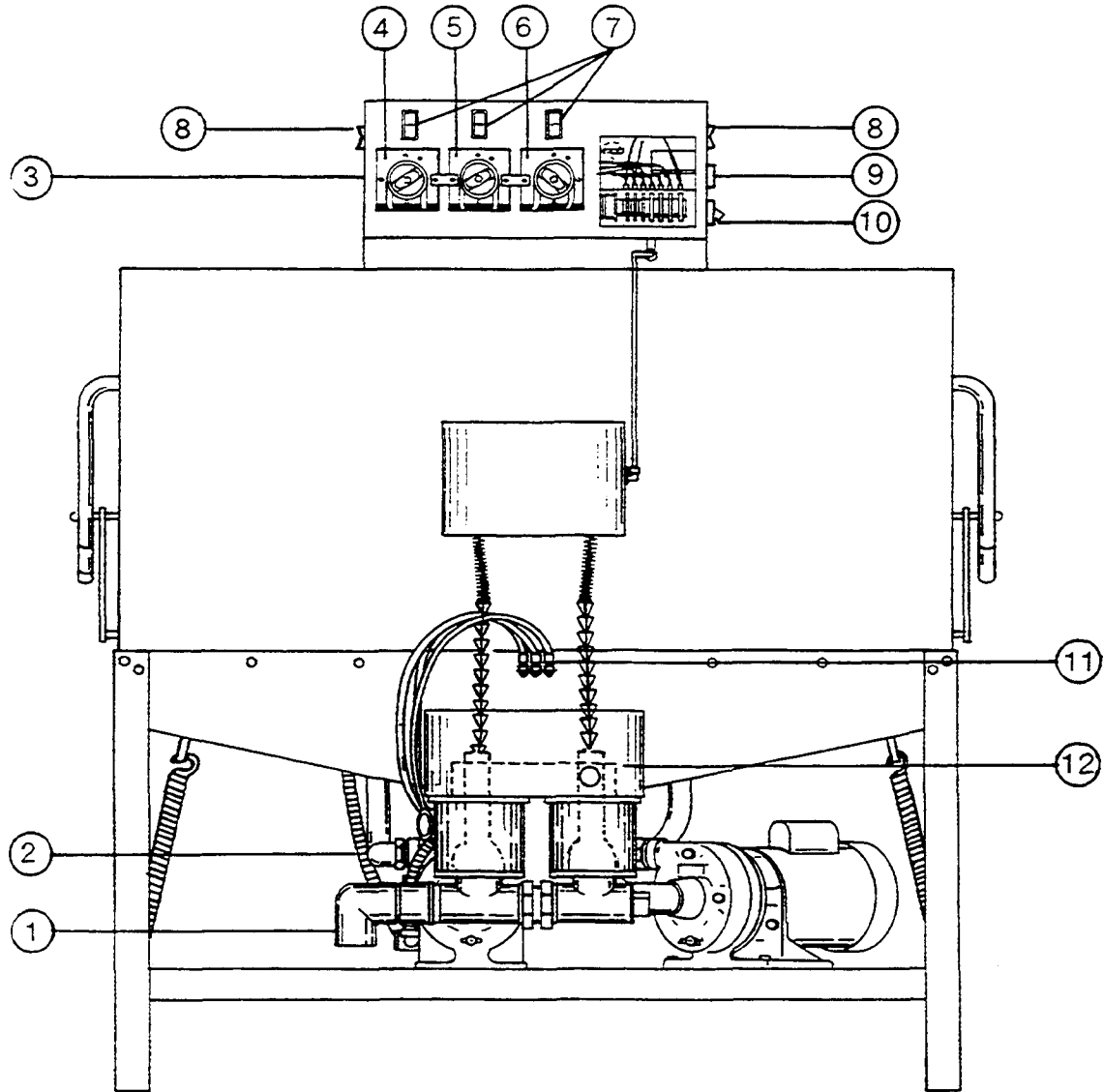

ITEM	P/N	DESCRIPTION		
1.		DRAIN OUTLET (2" GRAVITY FEED)		
2.		INCOMING WATER CONNECTION (3/4" IN BACK)		
3.		CUSTOMER ELECTRICAL SERVICE CONNECTION (IN BACK)		
4.	0046500	DETERGENT DISPENSER PUMP 115V, 60 CYCLE		
	0046000	DETERGENT DISPENSER PUMP 230V, 50 CYCLE		
5.	0046500	RINSE ADDITIVE DISPENSER PUMP 115V, 60 CYCLE		
			0046000	RINSE ADDITIVE DISPENSER PUMP 230V, 50 CYCLE
			6.	0046500
				0046000
			7.	0154300
			8.	0154300
			9.	0034000
			10.	0012000
			11.	
			12.	

GENERAL INSTRUCTIONS

(OPERATION)

Note: Read the following instructions carefully. Proper operation of your Conserver Dishwasher will ensure clean and sanitized glasses and dishes at optimum efficiency.

Dish Preparation:

1. Scrape dishes thoroughly.
2. Pre-wash by soaking or spraying with a pre-rinse hose.
3. Place dishes and cups in dish rack; cups, upside down.
4. Place glasses and silverware in combination glass silverware rack; glasses, upside down. Scatter silverware loosely on bottom. Do not put glasses on top of silverware.

Note: Silverware should be washed upright in a special compartment silverware rack for best results.

These silverware compartment racks are available through your dealer or service agency.

Machine Operation:

1. Insert drain strainers.
2. Be sure the drain stoppers are in place.
3. Insert two racks of dishes and close all doors.
4. Check the levels of the detergent, rinse additive and sanitizing agent containers. Fill them if necessary.
5. To put the unit into operation at the beginning of the day or a meal period, make sure the circuit breaker on the right side of the dispenser/control box on top of the machine is on.
6. For the initial fill, push the fill switch on the right side of the dispenser/control box. Hold the switch in this position until the water level reaches 5/16" above the top of the cut out for the drain opening.
7. When the unit is full of water press the start switch and count to three. This activates the time cycle and the cycle light will come on.
8. When the light goes out, open the side doors and slide out the racks of clean dishes. Slide in two racks of soiled dishes and repeat steps #7 and #8.
9. At the end of the mealtime, shut off the circuit breaker on the dispenser/control box and drain the unit by pulling on the drain stoppers. Clean any food debris out of the basket strainers.

Note: If the unit is not operated for extended periods of time, the water will drain out or go down in level. Be sure to check the water level before operating and if the level is down, see step #6

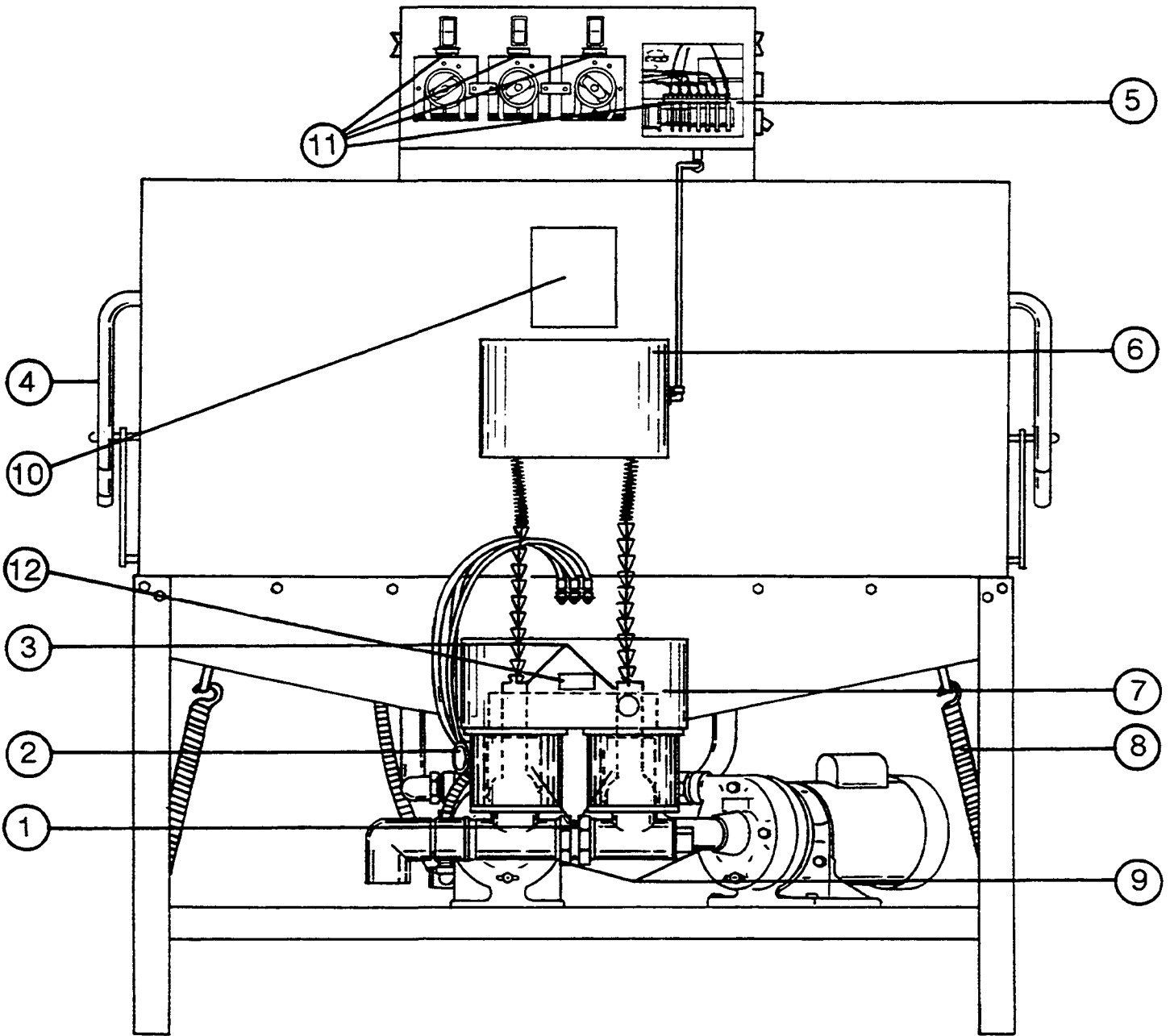

ITEM	P/N	DESCRIPTION
1.	0152100	PUMP INTAKE STRAINERS (2)
2.	0169000	WASH-RINSE WATER THERMOMETER
3.	0053813	DRAIN LINE STOPPERS (2)
4.	0008600	CANTILEVER ARM
5.	0171100	TIMER, 115V, 60 CYCLE
	0173200	TIMER, 220V, 50 CYCLE
6.	0054106	DRAIN SOLENOID "T" STYLE, 115V

ITEM	P/N	DESCRIPTION
7.		FILL LEVEL 5/16" ABOVE TOP OF CUTOUT FOR DRAIN
8.	0009000	CANTILEVER DOOR SPRING
9.	0087000	PUMP & MOTOR ASSEMBLY, 60 CYCLE
10.	0001210	OPERATIONS DECAL
11.	0001211	TIMER DECAL AND DET, SAN, RIN DECALS
12.	0001203	CLEAN STRAINER DECAL

GENERAL INSTRUCTIONS

(PREVENTIVE MAINTENANCE)

THE FOLLOWING IS TO BE PERFORMED AS NEEDED.

Note: Read the following instructions carefully. Proper maintenance of your Conservor Dishwasher will ensure optimum service with a minimum of down time. Before removing the cover to the Dispenser/Control Box turn off the circuit breaker on the side of the box.

1. Remove all lime and corrosion deposits. (Weekly or as needed.)

- a. Remove all three hoses for the pumps from their containers. b. Remove the three hoses from the sump on the front of the machine and place them off to the side in another container- This will prevent the chemicals from entering the sump during the cycling of the machine.
- c. Fill machine with wash water as would ordinarily be done for washing. d- Open door and place two cups or less of deliming compound into water. (Be sure to follow the amount and directions given on the package or bottle of the compound used.) The compound is available from your detergent supplier.
- e. Close door and push start switch. Run through four cycles.
- f. When cycle light goes out, open door and examine the interior. All lime should be removed and parts should be shiny. If not, scrub stubborn deposits with brush and repeat operation. (Protect hands with waterproof gloves.)
- g. After the interior is clean, turn off circuit breaker, empty wash water by removing the drain stoppers. Remove basket strainers and flush away all debris and build-up.
- h. Replace the basket strainers. Turn circuit breaker on to refill the machine and allow it to run through a cycle, then again drain as instructed in (f).
- i. Return the three hoses to the sump and install in the hose bracket.
- j. Return the three hoses to their proper containers and prime the pumps.

2. Clean the strainer baskets to provide for the maximum amount of water return to the pumps possible. (Daily or as needed.)

- a. Remove baskets from drain openings and brush away any debris or force it out of the strainer openings with water.

3. Clean Y-strainer on incoming water line. (Yearly or as needed.)

- a. Water to machine must be turned **off** for this operation.
- b. Remove plug and clean strainers (as water is trapped near strainer and 120° - 140°F, use care in removing plug and have container to catch water).

4. Clean Wash/Rinse tubes (Weekly or as needed.) (See drawing next page.)

- a. Turn the circuit breaker to **off** position.
- b. Open door and drain machine by lifting drain stoppers.
- c. When empty, replace drain stoppers.
- d. Loosen the two thumb screws opposite each other on each the top and bottom assemblies.
- e. Pull the assemblies out of the bases.
- f. Remove the hub assembly by loosening the nut with a wrench.
- g. After hub is off, remove the end plugs and either flush with clean water or a brush. (A straightened paper clip makes an excellent tool for cleaning the nozzles.)
- h. Clean the hub by either soaking or brushing with a deliming solution. (A toothbrush makes an excellent tool.)
- i. The bearings cannot be replaced separately; the whole hub must be replaced if it is needed.
- j. Reassemble the Wash/Rinse assembly by reversing steps d, e, f, and g.

5. Clean any deposits which may have built up on exterior moving parts. (Only as needed.)

- a. Remove with clean cloth. (A stainless polish or oil may be used to loosen deposits.)
- b. Deposits around fill switch can be removed with a dry toothbrush.

6. If an external scrap trap is supplied with the unit, flush the drain line and the scrap trap. (Weekly or as needed.)

- a. Remove the 2" pipe nipple on the end of the fitting underneath the drain outlet.
- b. Insert a hose into the line and flush the line out with a steady stream of water.
- c. Remove the scrap tray from the scrap trap and empty the food debris into a disposable container.

- d. Before reinstalling the scrap tray, flush the line from the machine to the trap, then from the trap to the drain line.
- e. Reinstall the scrap tray and replace the lid.
7. **Never allow the main pump to be operated without water in the machine.**
8. Inspect the peristaltic pumps on a weekly schedule for cracks in the tubes. On the right side of the dispenser/control box there is a counter to register each time the unit completes a full cycle. Anticipate about every 30,000 cycles having to replace the tubes in the peristaltic pumps. The tubes and instructions are available from your area parts distributor listed in the back of this manual.

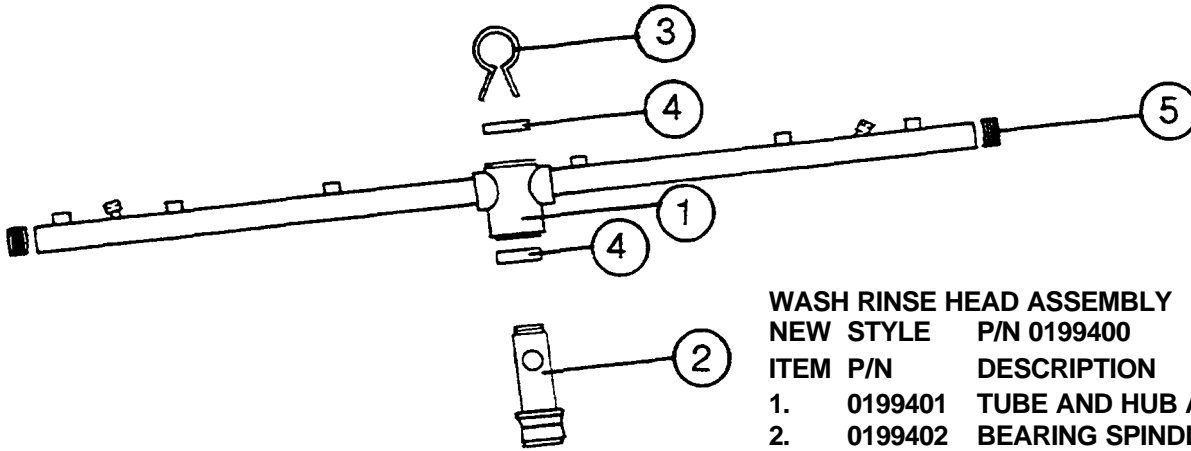

**WASH RINSE HEAD ASSEMBLY
NEW STYLE P/N 0199400**

ITEM	P/N	DESCRIPTION
1.	0199401	TUBE AND HUB ASSEMBLY
2.	0199402	BEARING SPINDLE
3.	0199403	RETAINING RING OR CLIP
4.	0199404	BEARINGS (2 EACH)
5.	0199501	END PLUGS

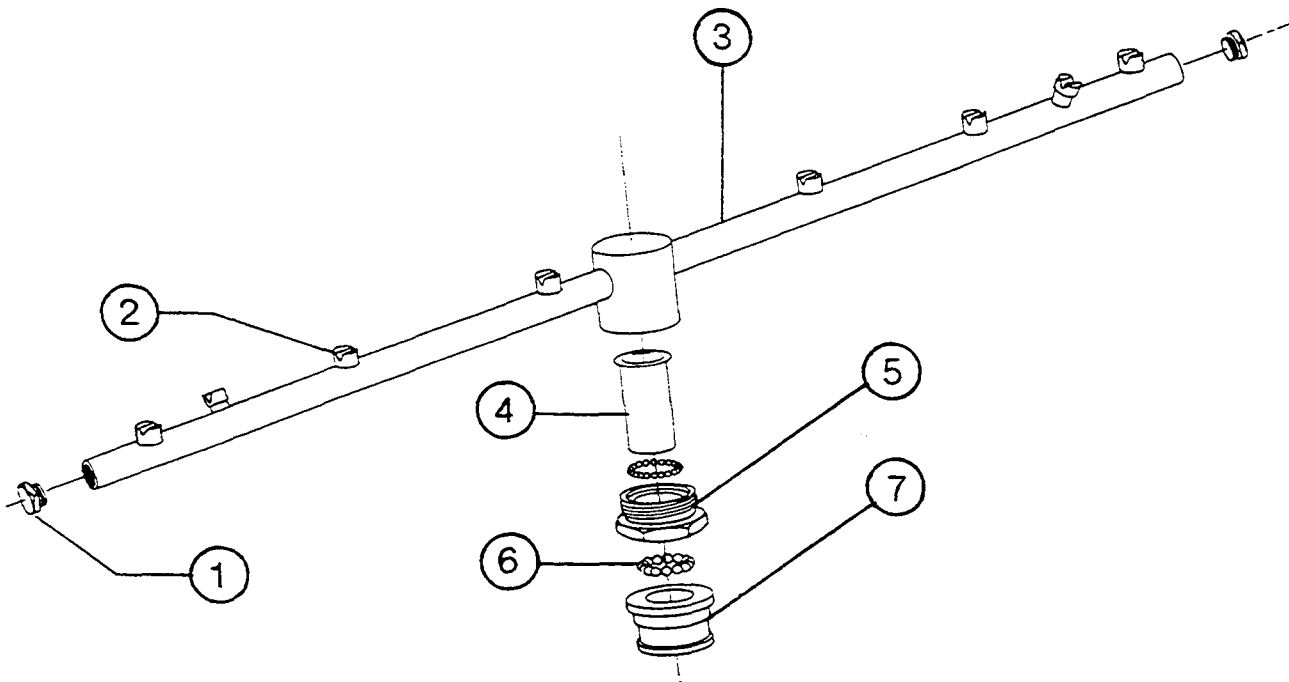

**WASH RINSE HEAD ASSEMBLY P/N 0199500
4 PER MACHINE**

ITEM	P/N	DESCRIPTION
1.	0199501	END PLUGS (4)
2.		VEE JETS (16)
3.	0199503	TUBE (4)
4.	0199504	INTERNAL SHAFT
5.	0199504	HEX BUSHING COMPLETE UNIT
6.	0199504	BEARINGS 4 EACH
7.	0199504	EXTERNAL SHAFT

TIMER ADJUSTMENTS

The timer is a self-contained (frame-mounted) timer of the repeating cycle type. It is mounted in the control box on the top of the machine to control the automatic functions of the machine. The timer motor operates on 110 VAC, 60 cycles, taking 90 seconds to complete **one full revolution**. There are six micro switches which are controlled by rotating cams driven by the timer motor. Two of the cams are fixed and cannot be adjusted. The remaining four cams are adjustable and can be adjusted to either lengthen or shorten the desired operation.

Remove the power to the machine when making all timer adjustments.

Included and taped in each control panel is a spanner wrench (as shown in the drawing). This wrench is needed to adjust the cams on the timer. The cams are preset at the factory but may have to be readjusted for different conditions of the country and for the different brands of detergent, rinse additive and sanitizing solutions. On both sides of the four adjustable cams, there are holes into which the spanner wrench is placed to apply leverage to make the desired change. The left side of the cam will always start an operation and the right side will end it. The cam on the right side is the one that will be adjusted more often since this one determines the length of the operation.

When making adjustments to the timer cams, be sure that the first cam next to the timer motor is in its stop position in the notch. Place one hand over the timer motor with your thumb lodged next to or on the first cam so that it will not move when the other cams are being adjusted. To make the adjustment, place the wrench in the holes on the right side of the cam. If a longer operating time is desired, increase the gap between the left and right side of the cam. If a shorter operating time is desired, decrease the gap between the left and right side of the cam. At the extreme end from the timer motor, there is a cam marked in five-degree increments. Every four degrees equals one second of the timer's revolution.

Function of each micro switch starting from the timer motor and going left to right

Timer Motor Micro Switch: controlled by a fixed cam that controls the total length of the cycle. It is activated by engaging the fill/start switch in the start position.

Detergent Micro Switch: controlled by an adjustable cam. It operates the peristaltic pump that dispenses the detergent. By adjusting the right side of the cam, you can either increase or decrease your amount of detergents.

Drain Solenoid Micro Switch: controlled by a fixed cam. It opens the solenoid valve during the cycle that drains the wash water out of the unit.

Fresh Water Solenoid Valve Micro Switch: controlled by adjustable cam. It is important that the unit have two-and-a-half gallons of water in it during the wash and rinse cycles. The proper level indicator is the height of the cut out leading into the drain strainer and stopper. By adjusting the right side of the cam, you can either increase or decrease your water supply to meet this required level. Fill water is turned on before drain cycle ends to ensure machine is flushed before filling.

Rinse Agent Micro Switch: controlled by an adjustable cam. It operates the peristaltic pump that dispenses the rinse agent. By adjusting the right side of the cam, you can either increase or decrease your amount of rinse additive. It should activate during the fill cycle.

Sanitizing Agent Micro Switch: controlled by an adjustable cam. It operates the peristaltic pump that dispenses the sanitizer solution. By adjusting the right side of the cam, you can either increase or decrease your amount of sanitizer solution. It should activate during the fill cycle. When the timer is preset at the factory, it is set to dispense 24 milliliters of detergent, 18 milliliters of rinse additive and 16 milliliters (50 parts per million) sanitizing agent based on an 8.4% solution of Sodium Hypochlorite.

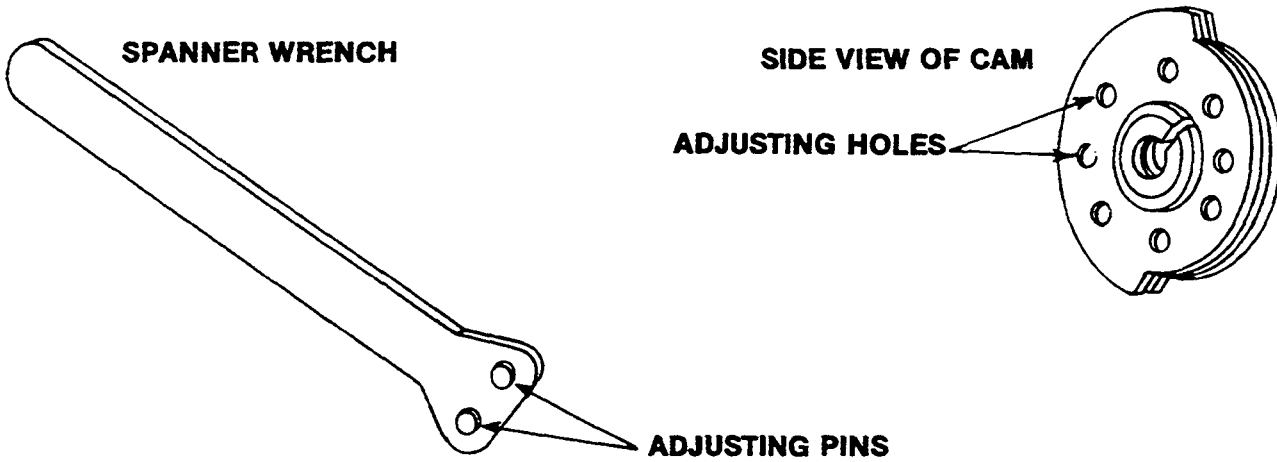
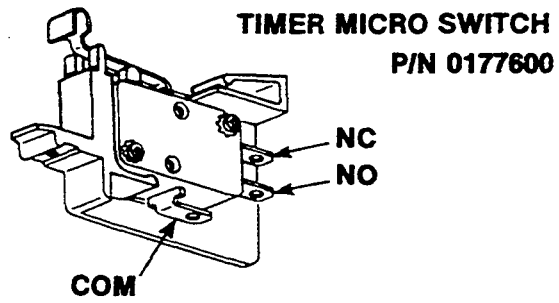

TIMER ASSEMBLY
P/N 0171100, 60 CYCLE
P/N 0173200, 50 CYCLE

1. TIMER MOTOR
2. TIMER MOTOR CAM (F)
3. DETERGENT CAM (A)
4. DRAIN SOLENOID CAM (F)
5. FRESH WATER SOLENOID CAM (A)
6. RINSE ADDITIVE AGENT CAM (A)
7. SANITIZING AGENT CAM (A)
8. DEGREE CAM (F)

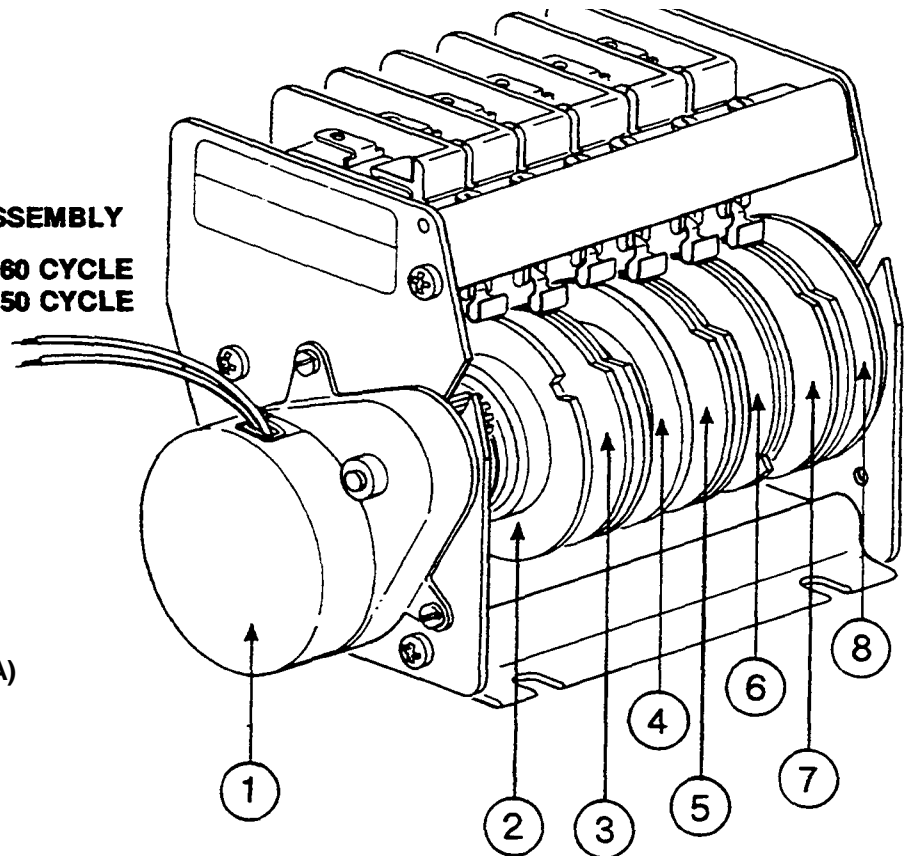

F—FIXED CAM
A—ADJUSTABLE CAM

FUNCTION of SWITCHES, CIRCUIT BREAKER, INDICATOR LIGHT and CYCLE COUNTER

Circuit Breaker — The circuit breaker is rated at 15 amps and is utilized as a protection device for the unit

Fill Switch — The Fill switch is a spring loaded momentary rocker switch and must be held in the up position until the water has reached the desired level.

Start Switch — The Start switch is a spring loaded momentary rocker switch and must be held in the up position for a count of three to start the automatic timer. There is a start switch on both sides of the control box.

Primer Switches — The primer switches are a spring loaded momentary rocker switch located over each peristaltic dispensing pump. The switches are utilized to operate the pumps when it is necessary to refill the intake tubes or pumps after they have been emptied. The pump is activated by pushing up on the switch and holding it for the desired length of time.

Cycle or Machine Light — This light comes on only when the automatic cycle is in progress and extinguishes when the cycle is complete.

Cycle Counter — The counter totals each single cycle that the unit goes through and is activated by the rinse additive micro switch on the timer. This counter cannot be reset

Power On Light — This light is lit all the time the circuit breaker is on.

REPLACEMENT of SWITCHES in CONTROL PANEL

There is one two basic type of manually operated switch utilized on the Conservor dishwasher. It is the rocker switch.

Before working on the machine, it is important that the power be turned off at the customer's circuit breaker. To prevent the possibility of electrical shock, trip the breaker to the **OFF** position. Then turn the machine circuit breaker **OFF** located on the side of the control box.

The rocker switch is mounted in a rectangular hole held in position by a bracket. This switch is designed to be released from the inside and pushed outward. The spring sides must be depressed to release the switch and bracket from the hole. To remove the bracket from the switch, wedge a screwdriver in between them then lift up and move off.

If the switch is found to be defective, mount a new one into the bracket and insert it into the hole in the control box. Make sure that the tab on the switch is in the proper notch on the bracket for easy operation of the switch. Replace the wires from the used switch terminal by terminal on to the new switch.

Power can now be applied to the dishwasher and run through cycles checking all operations.

ROCKER SWITCH

ITEM	DESCRIPTION
1.	CONNECTION TERMINALS
2.	BRACKET SPRING SIDES
3.	PANEL PLATE
4.	BRACKET FRONT
5.	ROCKER BUTTON

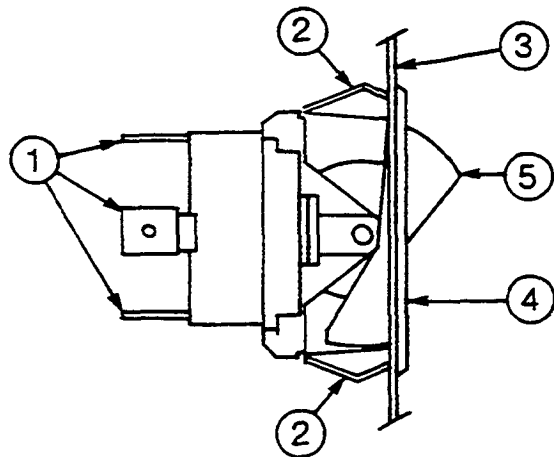

PERISTALTIC PUMP SANITIZING DISPENSING SYSTEM

The peristaltic pumps are mounted in the Control/Dispenser Box which is attached to the top of the unit. The pumps receive their electrical signals from two sources.

The first source is the primer switch, which is used to prime the pump when it is first put into operation and then every time the agent is changed and/or the tubes are clear of any solution.

The second source is the timer, which activates the pumps during the cycle at the proper time to dispense the correct agent when needed.

If control box is locked and access to prime switches is not available, just run dishwasher through several cycles to move liquid from storage bottles to pumps.

Checkout of Sanitizing Injector

The pump can be deemed operational if the following items are observed:

1. If the cam roller assembly rotates during each cycle.
2. If the solution is observed passing through the tube.

Note: Both of these operations must be observed to determine if the sanitizing agent is being dispensed.

If it is determined that the unit is not operating correctly, the following procedures will aid in correcting the problem:

1. Make certain that the tube is in the bottle of solution.
- 2- Make certain that there are no cracks in the tubing and particularly in the pump hose.
3. Check all wire connections on the pump, the timer cam, and the primer switch.
4. Check to see that there is no debris in the tubes.
5. Make sure that the tubing is inserted into the pump hose so that air is not drawn into the system.

SANITIZING AGENT INJECTOR

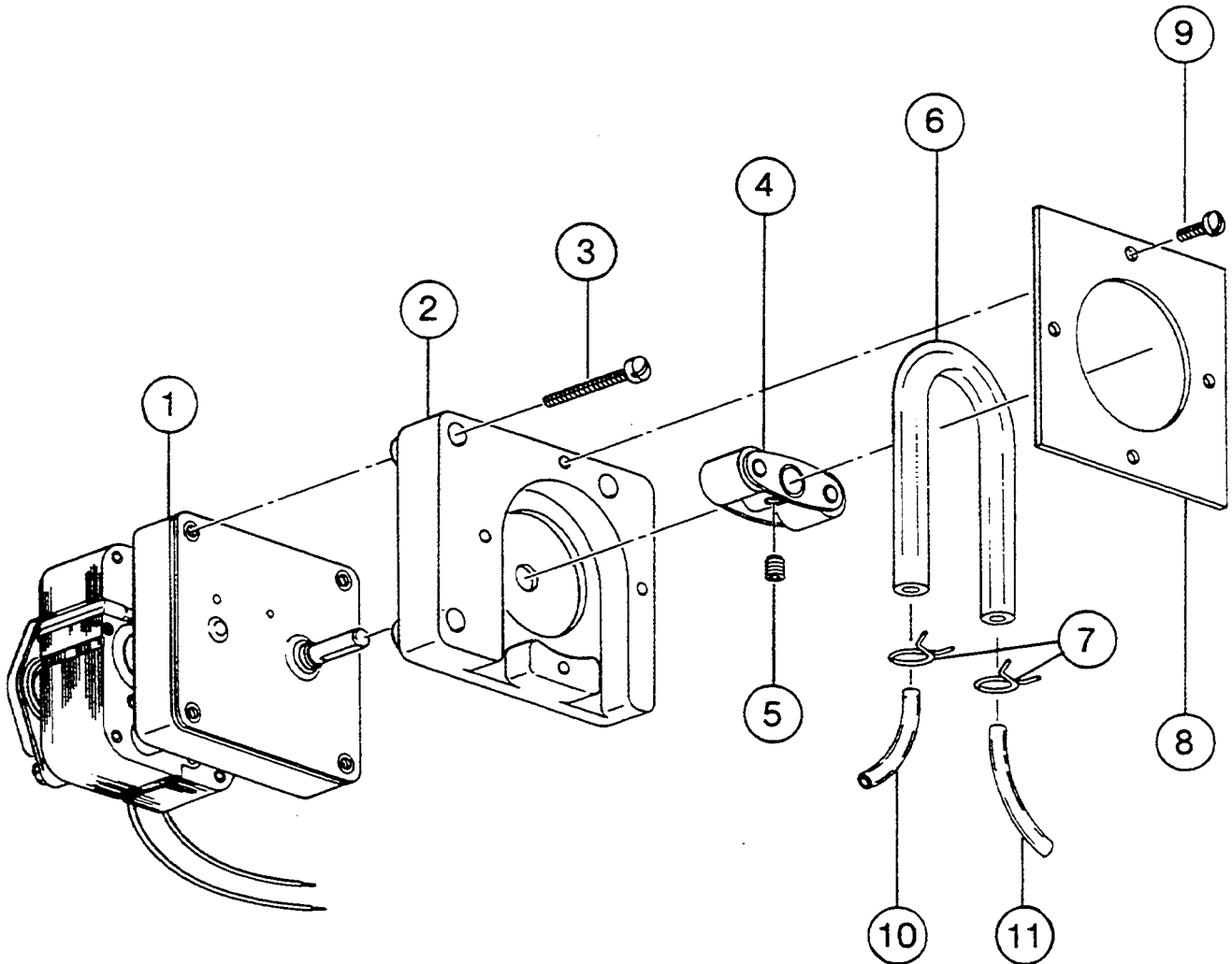

P/N465 COMPLETE PUMP ASSEMBLY, 60 CYCLE

ITEM	P/N	DESCRIPTION	ITEM	P/N	DESCRIPTION
1.	0046501	PUMP MOTOR, 60 CYCLE	8.	0046508	FACE PLATE
2.	0046502	PUMP HOUSING	9.	0046509	PLATE MOUNTING SCREWS (4) 8/32
3.	0046503	HOUSING MOUNTING BOLTS (3) 10/32 FILLSTER HEAD	10.	0046510	INTAKE OR SUCTION HOSE
4.	0046504	CAM ROLLER ASSEMBLY	11.	0046510	OUTPUT OR INJECTOR HOSE
5.	0046505	CAM ROLLER SET SCREW			
6.	0046506	PUMP HOSE			
7.	0046507	HOSE CLAMPS			

It is important to obtain the name of the correct type of pump/motor assembly before ordering these replacement parts, as needed. Both assemblies can be identified by the data plates, which will indicate either the GOULDS or CENTURY Motor.

PLEASE REFER TO THE ILLUSTRATION WITH PARTS BREAKDOWN LIST OF BOTH ASSEMBLIES

Note: The Goulds Pump/Motor Assembly may be used in place of the Price Pump/Century Motor. However, new mounting holes **MUST** be drilled for proper placement.

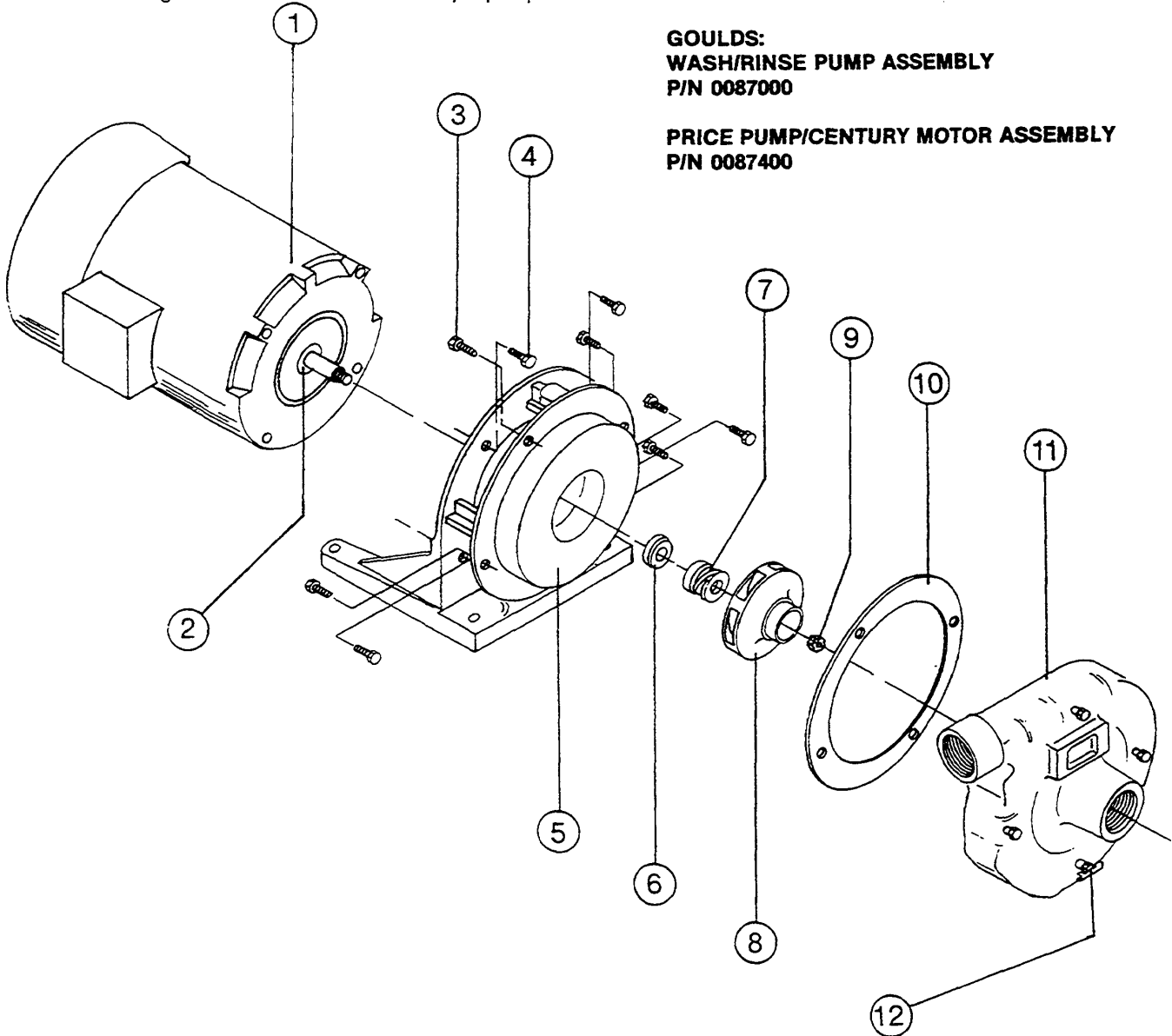

**GOULDS:
WASH/RINSE PUMP ASSEMBLY
P/N 0087000**

**PRICE PUMP/CENTURY MOTOR ASSEMBLY
P/N 0087400**

GOULDS ASSEMBLY:

ITEM	P/N	DESCRIPTION
1.	0087001	MOTOR, 110V, 1 HP.3450 RPM
2.	0087002	MOTOR SHAFT DEFLECTOR
3.	0087003	HOUSING TO FLANGE CAP SCREW
4.	0087004	HOUSING TO MOTOR CAP SCREW
5.	0087005	HOUSING
6.	0087006	CERAMIC FACE FOR SEAL
7.	0087006	MECHANICAL SEAL
8.	0087008	IMPELLER
9.	0087009	IMPELLER NUT
10.	0087010	FLANGE GASKET
11.	0087911	FLANGE
12.	0087912	FLANGE PETCOCK

PRICE PUMP/CENTURY MOTOR ASSEMBLY:

- 1. 0087401 - Motor • Century
- 6. & 7. 0087403 - Mech. Seal & Ceramic Face
- 8. 0087404-Impeller
- 10. 0087402 - Gasket

REPLACING SEAL and CERAMIC on WASH/RINSE PUMP

Function:

The pump is part of the total motor-pump system and utilizes one shaft seal and ceramic to prevent the pump from leaking around the impeller and shaft. One gasket is used to prevent leakage between the pump housing and the pump flange.

Replacement of Seal and/or Ceramic

1. Remove the power source to the machine by turning the circuit breaker to its **OFF** position on the side of the control/dispenser box.
2. Drain the system by raising the plunger and leaving it at an angle to allow all of the water to drain out of the unit. Open the petcock on the pump and drain the water from the pump into a catch basin.
3. Remove the four bolts that are holding the pump unit to the base of the machine.
4. Remove the eight bolts that hold the pump housing to the pump flange. This will eliminate having to remove the plumbing going into and coming out of the pump flange.
5. Pull the motor and the remaining pump parts away from the pump flange and plumbing. If unable to work on the pump at its present location, disconnect the wires and move it to a stable location.
6. To remove the impeller jam nut insert a screwdriver into one of the passages of the impeller and back off the jam nut with a 5/8" socket and wrench. 7- Remove the impeller by inserting a screwdriver in the end of the motor shaft to prevent it from turning and unscrew the impeller in a counter clockwise direction from the shaft.
8. To remove the mechanical seal from the shaft, place two screwdrivers opposite each other with their flat edges under the seal with the shank of the screwdrivers against the housing. Push on the screwdrivers with equal force and this will pry the seal off of the shaft.
9. After removing the four bolts that hold the housing to the motor, take off the housing and place it on a flat surface. Push out the ceramic seat and rubber cup being careful not to touch the housing.
10. Clean thoroughly the flange and housing gaskets of any scale or dirt build up. Clean the counterbore where the ceramic seat is located and the shoulder of the motor shaft that fits next to the impeller.
11. To enable the ceramic face and rubber cap to be installed in the housing squarely and evenly the counterbore in the housing and the rubber cup should be coated with a thin film of oil. Press the ceramic face and rubber cup into the counterbore of the housing using your thumbs. Apply even pressure all the way around to ensure a good tight fit, but be careful not to damage the top of the ceramic face.
12. Replace the housing on the motor being very careful not to damage or move the ceramic when passing the shaft through the ceramic. Tighten the four bolts tightly.
13. Apply a thin film of oil to the new mechanical seal and press it into place by placing a piece of tubing over the shaft and pushing it toward the ceramic face. The face of the seal has to fit snugly against the surface of the ceramic face. Be very careful not to allow the ceramic face to come out of the rubber cup while installing the seal.
14. Reassemble the pump and motor by reversing the procedure in steps 1-9. Close petcock on pump.

Caution: Do not operate unit until pump is filled with water.

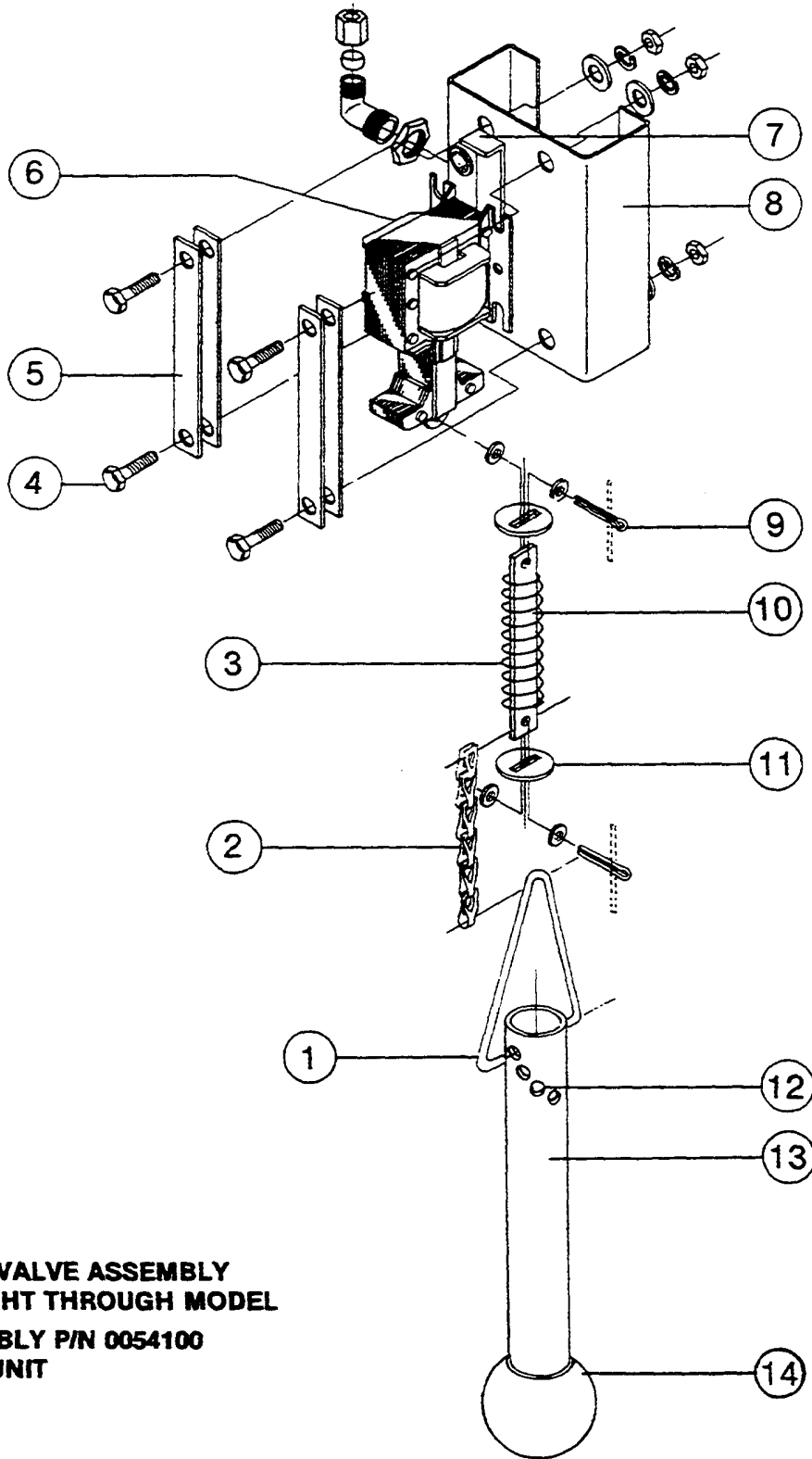

**DRAIN VALVE ASSEMBLY
STRAIGHT THROUGH MODEL
ASSEMBLY P/N 0054100
2 PER UNIT**

ITEM	P/N	DESCRIPTION
1.	0054101	BOLT, CHAIN TO STOPPER
2.	0054102	CHAIN TO STOPPER
3.	0054103	LINK SPRING
4.	0054104	BOLTS (4) SOLENOID TO PLATE
5.	0054105	SOLENOID COIL STRAPS
6.	0054106	SOLENOID COIL, 115V

ITEM	P/N	DESCRIPTION
7.	0054107	ADJUSTING LEVER
8.	0054108	MOUNTING PLATE
9.	0054109	COTTER PINS (2)
10.	0054110	LINK
11.	0054111	LINK WASHERS (2)
12.		STOPPER HEIGHT ADJUSTMENT
13.	0053812	STOPPER
14.	0053813	STOPPER BALL

SERVICE INSTRUCTIONS

(INCOMING WATER SOLENOID VALVE)

SOLENOID VALVE P/N
0143400, 115V 2 PER UNIT P/N 0143000, 220V

To Take The Valve Apart

Disassembly—These valves may be taken apart by unscrewing the bonnet and the enclosing tube assembly from the valve body assembly. See Fig. 3. After unscrewing, carefully lift off the bonnet and enclosing tube assembly. Don't drop the plunger. The "O" ring seal and diaphragm cartridge can now be lifted out.

Be careful not to damage the machined faces while the valve is apart.

To Reassemble—Place the diaphragm cartridge in the body with the pilot port extension UP. Hold the plunger with the synthetic seat against the pilot port. Make sure the "O" ring is in place, then lower the bonnet and enclosing tube assembly over the plunger. Screw bonnet assembly snugly down on the body assembly.

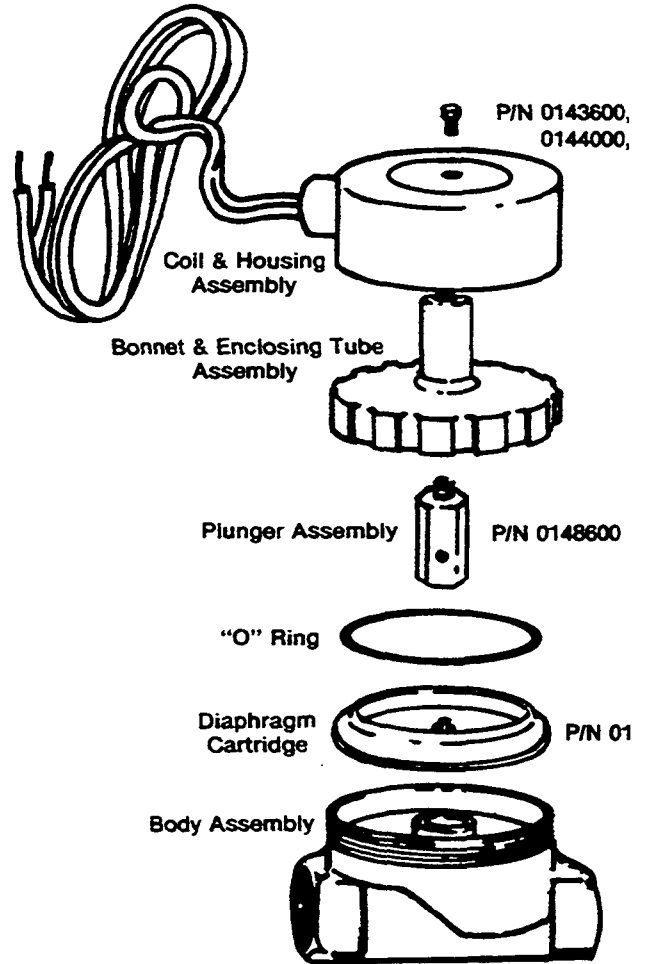
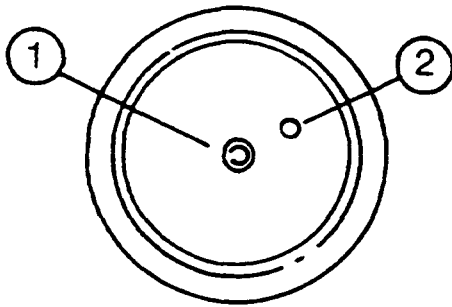

FIG.3

DIAPHRAGM CARTRIDGE



Possible Problems:

Pilot Port extension #1 clogged. Hole #2 clogged.

Remedy:

Pass heated straight pin through hole #2 or clean hole #1.

INSTRUCTIONS for ADJUSTING TENSION of CANTILEVER

Problem: Doors raise hard, but lower easily.

Solution:

1. Back off (loosen) upper adjusting nuts (F) on both eyebolts (E) about two or three complete turns.
2. Tighten lower adjusting nuts (G) on both eyebolts (E) a complete turn.
3. Check door for easy operation. Adjust further, if necessary.
4. When adjustment is completed, tighten upper adjusting nuts (F) down against angle to lock in position. Check both eyebolts.

Problem: Doors raise easily, but lower hard.

Solution:

1. Back off lower adjusting nuts (G) carefully, making sure there is still some thread on eyebolt available (both eyebolts).
2. Check door for easy operation. Adjust further, if necessary.
3. When adjustment is complete, tighten upper adjusting nuts (F) down against angle to lock in position. Check both eyebolts.

Problem: Doors sticking, or are hard to move up and down.

Solution:

1. Raise doors.
2. Clean inside door channels on machine with a good cleaning compound. It may be necessary to remove doors to completely clean channel. If so, remove only one door at a time. Make sure cantilever has stop to prevent pulling other door up and out of channel. If it does not have stop, secure cantilever arm to machine with doors in the closed position.
3. Build-up should be completely removed so it may be necessary to use an abrasive pad (non-metallic) to clean.
4. While you have the door out of channel, make sure it is not dented or crooked. If channel is crooked or dented, use 1/2" wide block to spread to proper opening.
5. Clean nylatron runners on the doors or replace nylatron, if excessively worn. See instructions on door runners.
6. Check door channels on machine for evenness and burrs. 7. After replacing doors, check for proper operation by raising and lowering with cantilever.

Problem: One side of door higher than other and does not close completely.

Solution:

1. Straighten cantilever arm.
2. This can sometimes be accomplished while arm is on machine by forcing down on the arm connected to the high door while the other side of the cantilever is pulled up.
3. If step two cannot be accomplished on machine, cantilever will have to be removed and straightened.

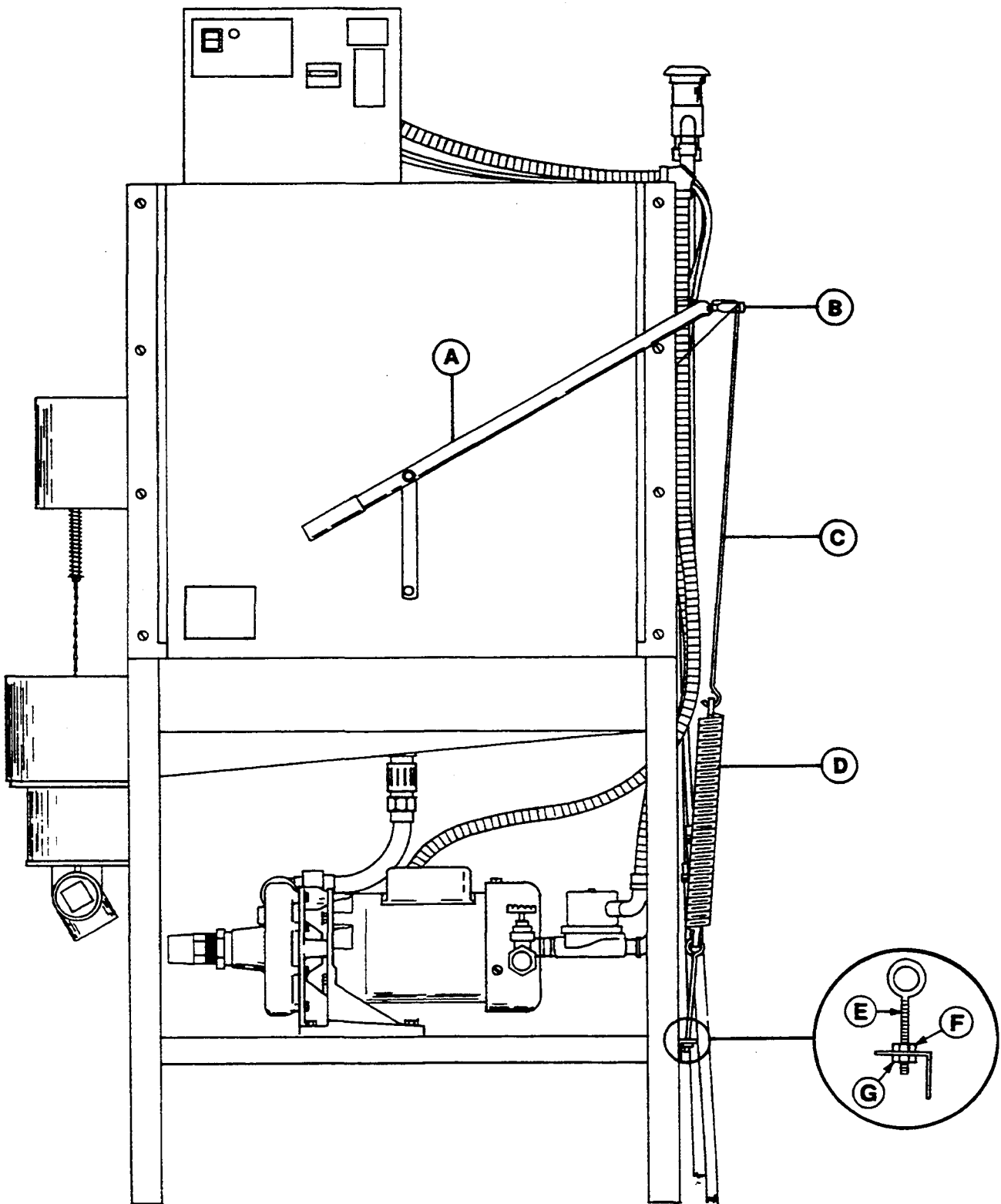

APPLYING NYLATRON STRIP to CONSERVER DOOR

It's important when removing the old door guides that the surface be cleaned thoroughly. This can be done with a solvent that will dissolve the remaining glue and/or the use of a fine sandpaper to scratch the surface where the door guide would make contact with the stainless steel door.

After this is accomplished and you are quite convinced that the surface is cleaned of all oil, glue, dirt, detergent, etc., then the door guide should be placed on a flat surface and a bed of silicone adhesive or any good non-hardening glue should be laid on the inside of the door guide's surface (top to bottom, making sure that none of the exposed surface to the outside has any glue on it).

Take the door guide and snap it over the door's edge as described in the attached sketch. Let this door set for at least one hour before use so that the glue or adhesive has a chance to set somewhat.

If these instructions are followed, the door guides should adhere to the door.

Fig. 1 - PUT A STREAM OF SILASTIC OR NON-HARDENING ADHESIVE IN INSIDE CORNER OF STRIP.

Fig. 2 - SIDE VIEW OF NYLATRON STRIP.

Fig. 3-SNAP STRIP ON DOOR LIP.

NOTE: DO NOT SLIDE STRIP FROM END ALWAYS SNAP ON.

Fig. 4 - PRESS DOWN WITH THUMB AND INWARD WITH FINGERS

Fig. 5 - FINISHED APPLICATION -END VIEW.

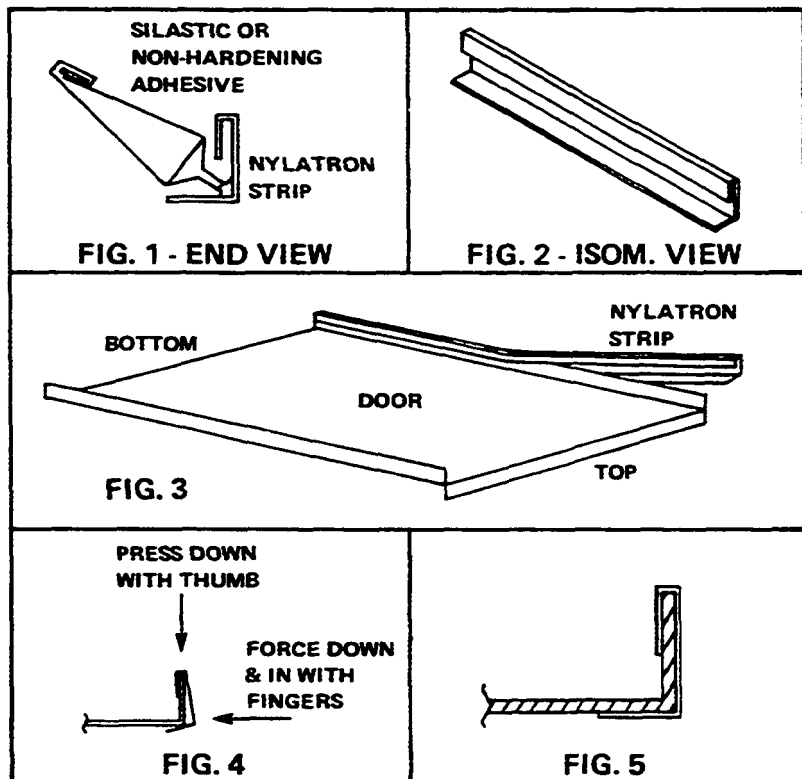

TROUBLE SHOOTING GUIDE

PROBLEM	CAUSE	SOLUTION
Nothing on machine operates.	<ol style="list-style-type: none"> 1. No voltage to dishwasher. <ol style="list-style-type: none"> a. Customer's fuse blown or circuit breaker tripped. 2. Machine circuit breaker tripped or turned off. 3. Voltage to machine low or circuit to machine broken. 	<ol style="list-style-type: none"> a. Replace or reset. 2. Turn on or reset. 3. Contact your electrician and/or power company for repair.
Will not fill with electrical power applied even though other components work.	<ol style="list-style-type: none"> 1. Water hand valve off. 2. Fill switch faulty or loose wire connection. 3. Solenoid valve does not operate. 	<ol style="list-style-type: none"> 1. Turn hand valve on. 2. Replace switch or wire terminal. 3. Contact your service agent, electrician or power company for repair.
Water runs continuously with power on.	<ol style="list-style-type: none"> 1. Fill switch sluggish or faulty. 2. Solenoid valve dirty or faulty. 	<ol style="list-style-type: none"> 1. Replace. 2. Contact your service agent, plumber or local repair man.
Water runs with no electrical power applied to solenoid. (master switch off).	<ol style="list-style-type: none"> 1. Water pressure excessive. 	<ol style="list-style-type: none"> 1. Check using pressure gauge during the flow period (solenoid valve open) should read 20 PSI, if in excess installation of a Pressure Reducer can reduce pressure.
Vacuum breaker leaks.	<ol style="list-style-type: none"> 1. Limed up. 2. Faulty. 	<ol style="list-style-type: none"> 1. Disassemble: a. Remove top using flat jaw wrench or channel locks. b. Remove poppet. c. Clean poppet and V.B. top and body. d. Replace parts removed. 2. Replace needed parts or whole V.B.
Wash arms spray water, but do not	<ol style="list-style-type: none"> 1. Race ways, where ball bearings rotate, rough or full of food particles. 	<ol style="list-style-type: none"> 1. See instructions for preventative
Wash water only sprays up and out of tubes a couple of inches.	<ol style="list-style-type: none"> 1. Pump drain strainer clogged. 2. Pump impeller worn or broken (only after many years of use). 3. Obstruction in pump chute or wash manifold. 4. Wash arms clogged. 	<ol style="list-style-type: none"> 1. Remove pump drain strainer and 2. Contact your service agent 3. Contact your service agent 4. Clean arm.
Wash motor does not operate Indicator light does not glow at any time.	<ol style="list-style-type: none"> 1. Faulty. 1. Lights faulty or poor connection. 	<ol style="list-style-type: none"> 1. Contact your service agent 1. Replace or correct connection.

TROUBLE SHOOTING GUIDE

PROBLEM	CAUSE	SOLUTION
None of the automatic functions work (wash, rinse)	<ol style="list-style-type: none"> 1. Start switch faulty. 2. Wire connections poor. 3. Time rinse or wash micro switch faulty. 	<ol style="list-style-type: none"> 1. Check switch. Replace if necessary, see instructions page concerning replacement of switches in control panel. 2. Correct connection. 3. Contact your service agent
Level of agents in bottle does not change.	<ol style="list-style-type: none"> 1. Defective agent pump (peristaltic). 2. Suction hose (intake tube) out of supple bottle. 3. Tubes in peristaltic pumps worn. 	<ol style="list-style-type: none"> 1. Replace. 2. Return to bottle. 3. Replace tubes.
Machine will not drain.	<ol style="list-style-type: none"> 1. Timer micro switch defective. 2. Drain solenoid defective. 3. Chain to stopper broken. 4. Debris clogged around stopper. 	<ol style="list-style-type: none"> 1. Replace. 2. Replace or contact local service agent 3. Repair with wire and/or replace. 4. Clean out

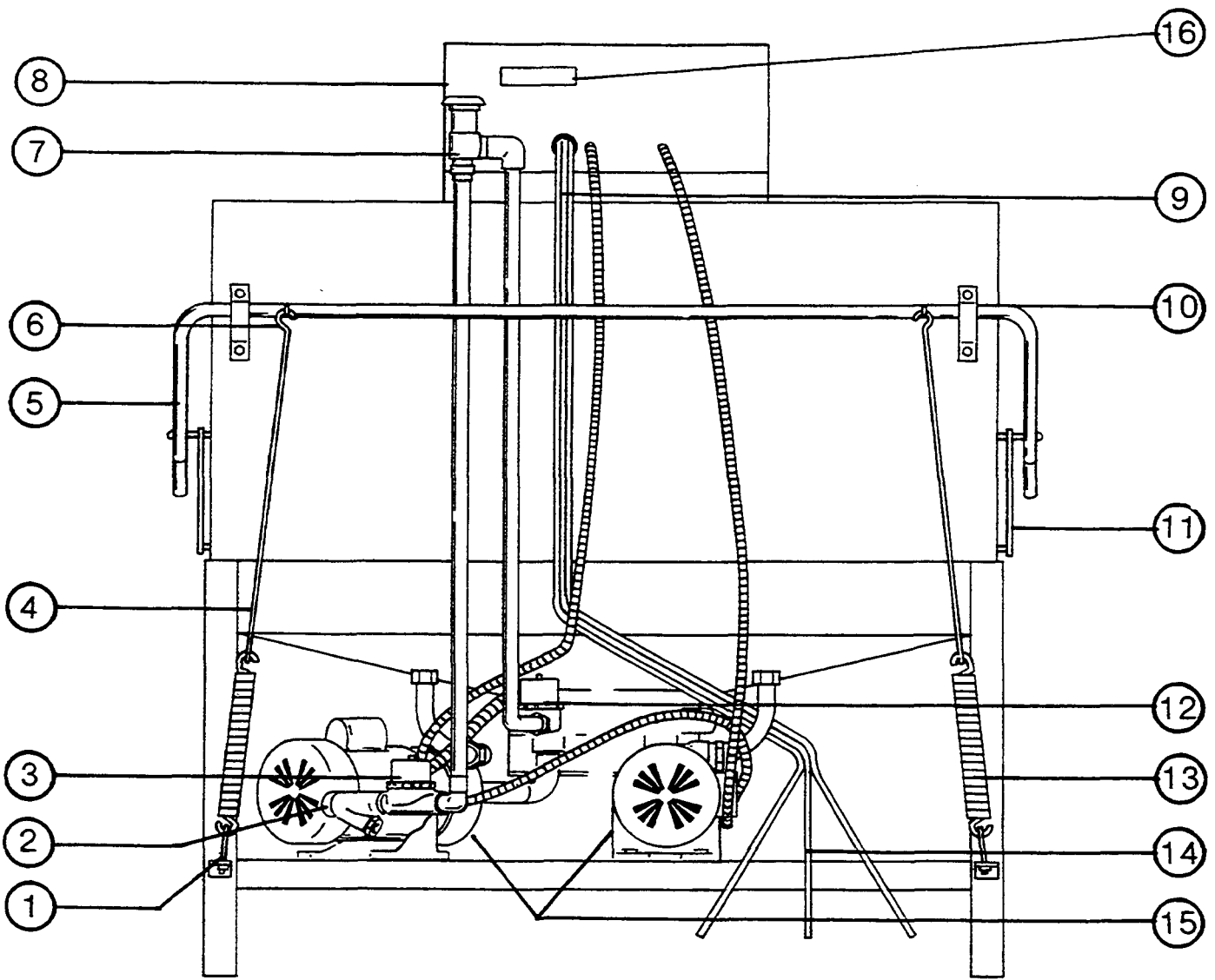

BACK VIEW

ITEM	P/N	DESCRIPTION
1.	0009400	CANTILEVER EYE BOLT
2.		INCOMING WATER CONNECTION 3/4"
3.	0143400 0185500 0143000	SOLENOID VALVE OR ANTI-FOAM VALVE SOLENOID VALVE, 220V
4.	0009000	SPRING ROD
5.	0008600	CANTILEVER ARM
6.	0009100	CANTILEVER YOKE ASSEMBLY
7.	0184301	VACUUM BREAKER
8.	0020600	CONTROL & DISPENSER BOX

ITEM	P/N	DESCRIPTION
9.		DISPENSER TO SUMP TUBING
10.	0008200	CANTILEVER MOUNTING BRACKET
11.	0011501	CANTILEVER DOOR COUPLER
12.	0143400 0143000	SOLENOID VALVE SOLENOID VALVE, 220V
13.	0009000	CANTILEVER SPRINGS
14.	0046512	DISPENSER INTAKE TUBING
15.	0087000	PUMP & MOTOR ASSEMBLY (2), 110V, 60 CYCLE
	0086900	PUMP MOTOR, 220V, 50 CYCLE
16.	0001201	110V POWER SUPPLY DECAL

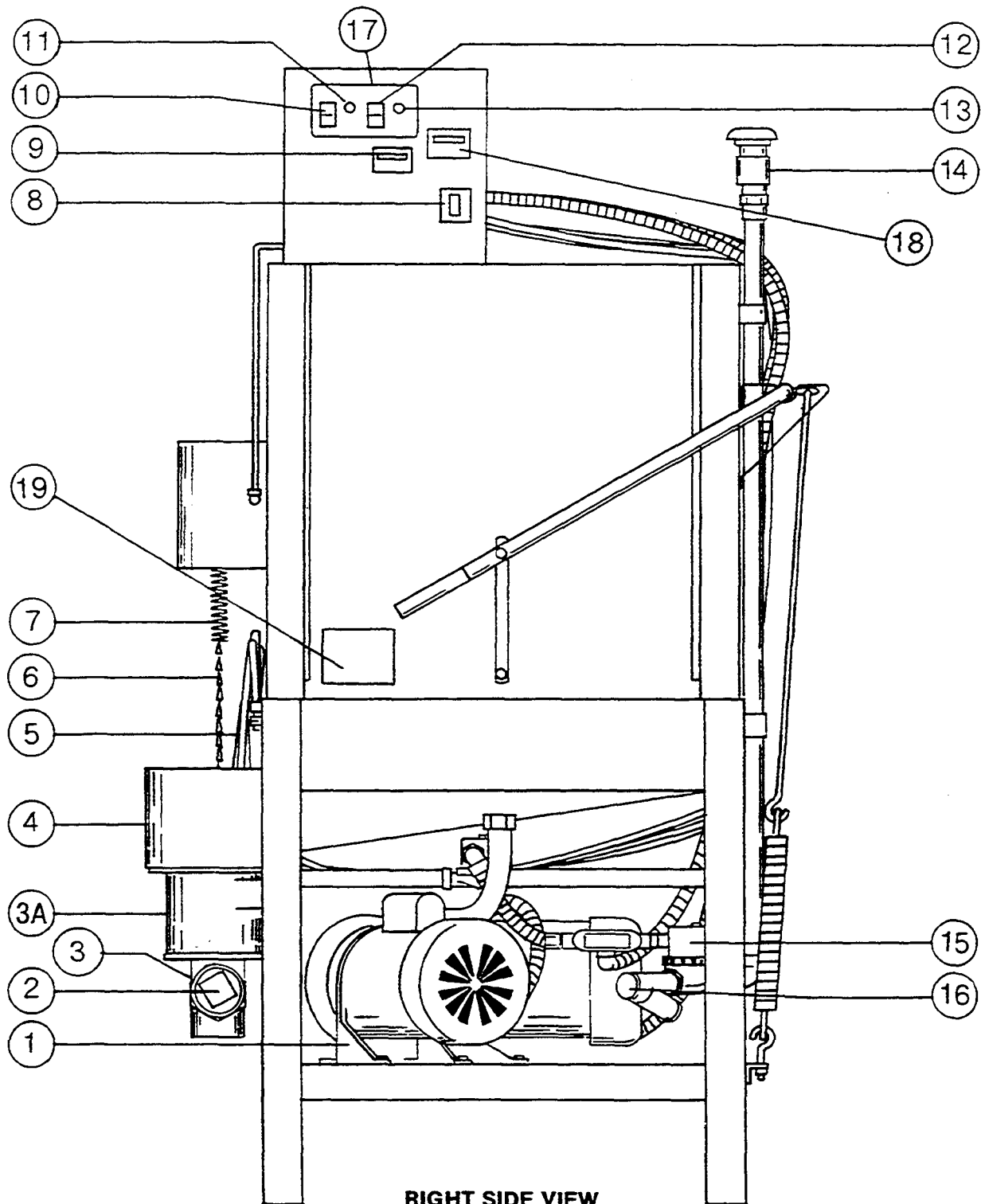

RIGHT SIDE VIEW

ITEM	P/N	DESCRIPTION	ITEM	P/N	DESCRIPTION
1.	0087000	PUMP & MOTOR ASSEMBLY (2), 60 CYCLE	10.	0154300	START SWITCH
2.	0086900	PUMP MOTOR, 50 CYCLE CUSTOMER CLEAN OUT FITTING	11.	0083500	CYCLE LIGHT
3.	0054203	DRAIN TEE-SUMP	12.	0154300	FILL SWITCH
3A.	0054200	DRAIN HOUSING L/H	13.	0083500	POWER ON LIGHT
	0054200	DRAIN HOUSING R/H	14.	0184300	VACUUM BREAKER
4.		DRAIN SUMP	15.	0143400	SOLENOID VALVE, 110V
5.		DISPENSER HOSES		0143000	SOLENOID VALVE, 220V
6.	See	DRAIN, CHAIN TO STOPPER	16.		INCOMING WATER CONNECTION 3/4"
7.	page 18	DRAIN, LINK & SPRING	17.	0001208	FILL & START SWITCH DECAL
8.	0012000	CIRCUIT BREAKER	18.	0001202	WARNING DECAL
9.	0034000	CYCLE COUNTER	19.	0001204	DOOR CAUTION DECAL

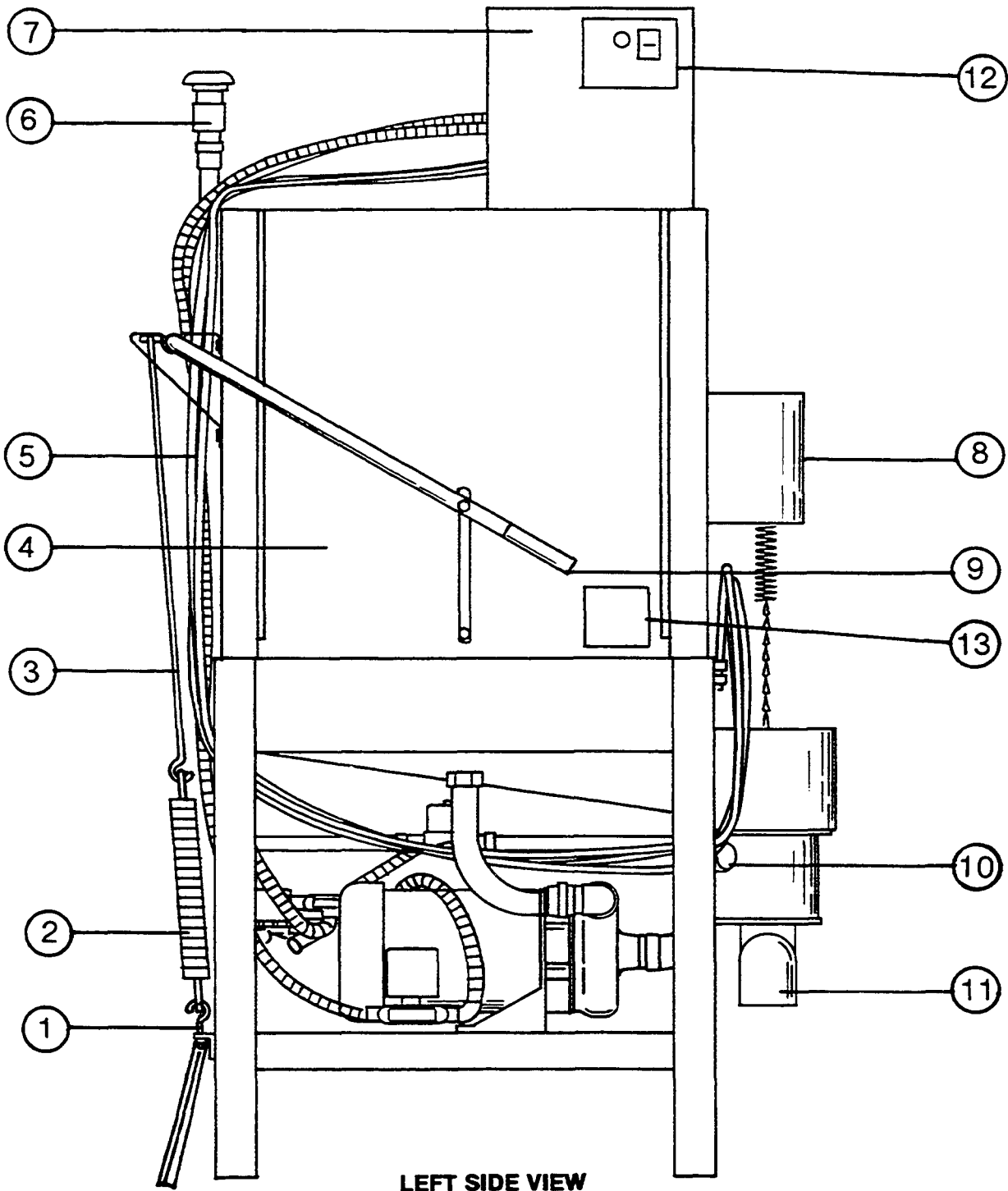

LEFT SIDE VIEW

ITEM	P/N	DESCRIPTION	ITEM	P/N	DESCRIPTION
1.	0009400	CANTILEVER EYE BOLTS	8.	0054100	DRAIN SOLENOID COVER
2.	0009000	CANTILEVER SPRINGS	9.	0008400	CANTILEVER HANDLE GRIPS
3.	0008700	CANTILEVER SPRING ROD	10.	0189000	WASH/RINSE THERMOMETER
4.	0048000	DOOR, SIDE	11.		CUSTOMER DRAIN CONNECTION 2"
5.		DISPENSER INTAKE TUBING	12.	0001209	LH START SWITCH DECAL
6.	0184300	VACUUM BREAKER	13.	0001204	DOOR CAUTION DECAL
7.	0020600	CONTROL & DISPENSER BOX			

MERCURY RELAY P/N 0122600, 110V
 MERCURY RELAY P/N 0122700, 220V

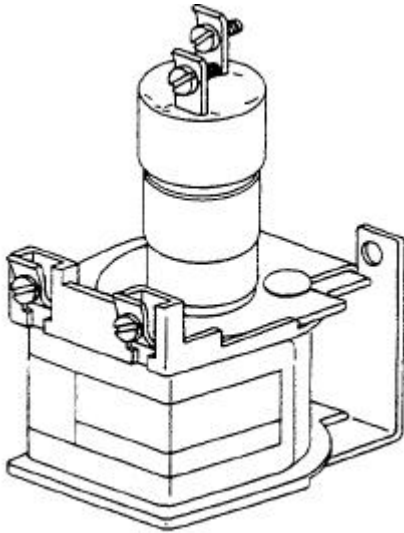

VACUUM BREAKER P/N 0184301

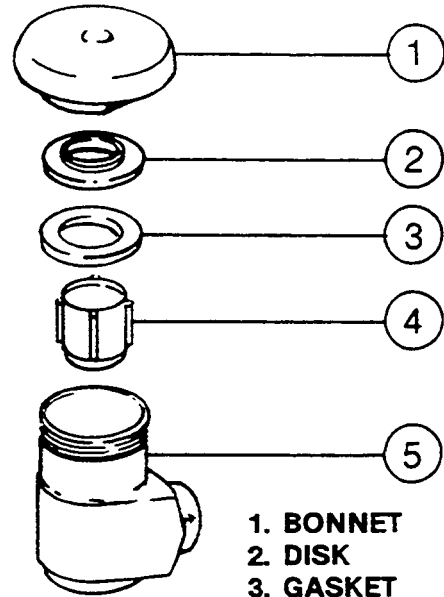

- 1. BONNET
- 2. DISK
- 3. GASKET
- 4. POPPET
- 5. BODY

REPAIR KIT P/N 0184400

INCOMING PLUMBING

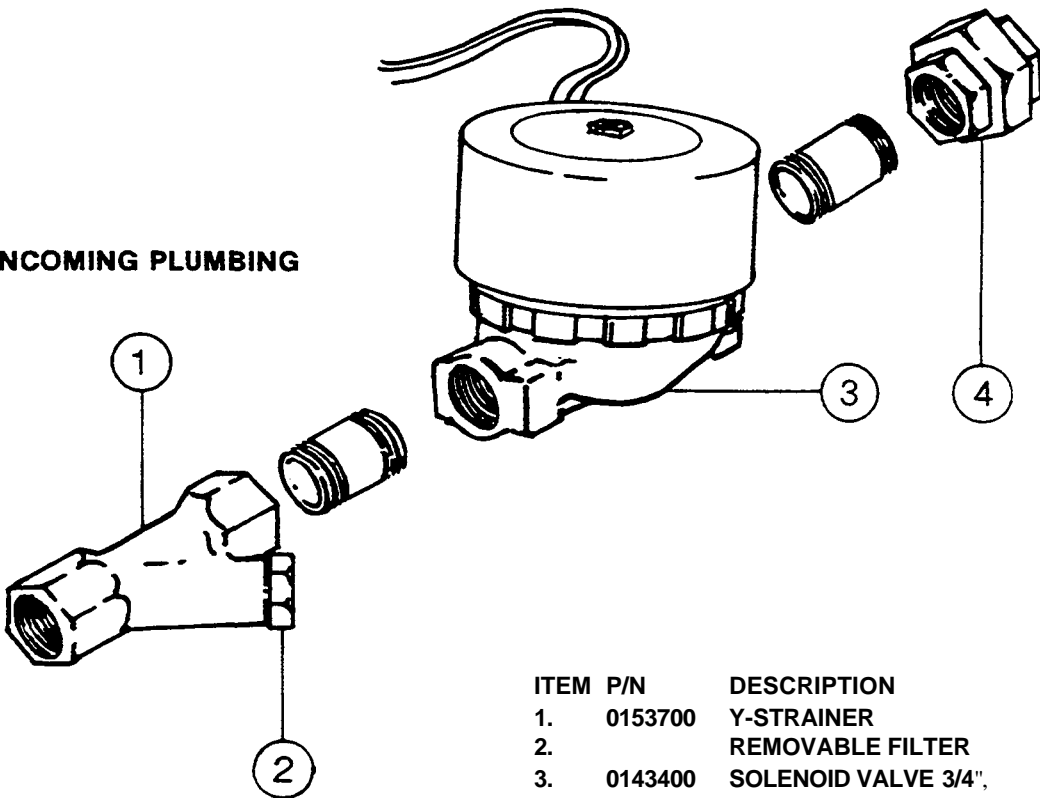

ITEM	P/N	DESCRIPTION	
1.	0153700	Y-STRAINER	
2.		REMOVABLE FILTER	
3.	0143400	SOLENOID VALVE 3/4",	110V
	0143000	SOLENOID VALVE 3/4",	220V
4.		PIPE UNION	

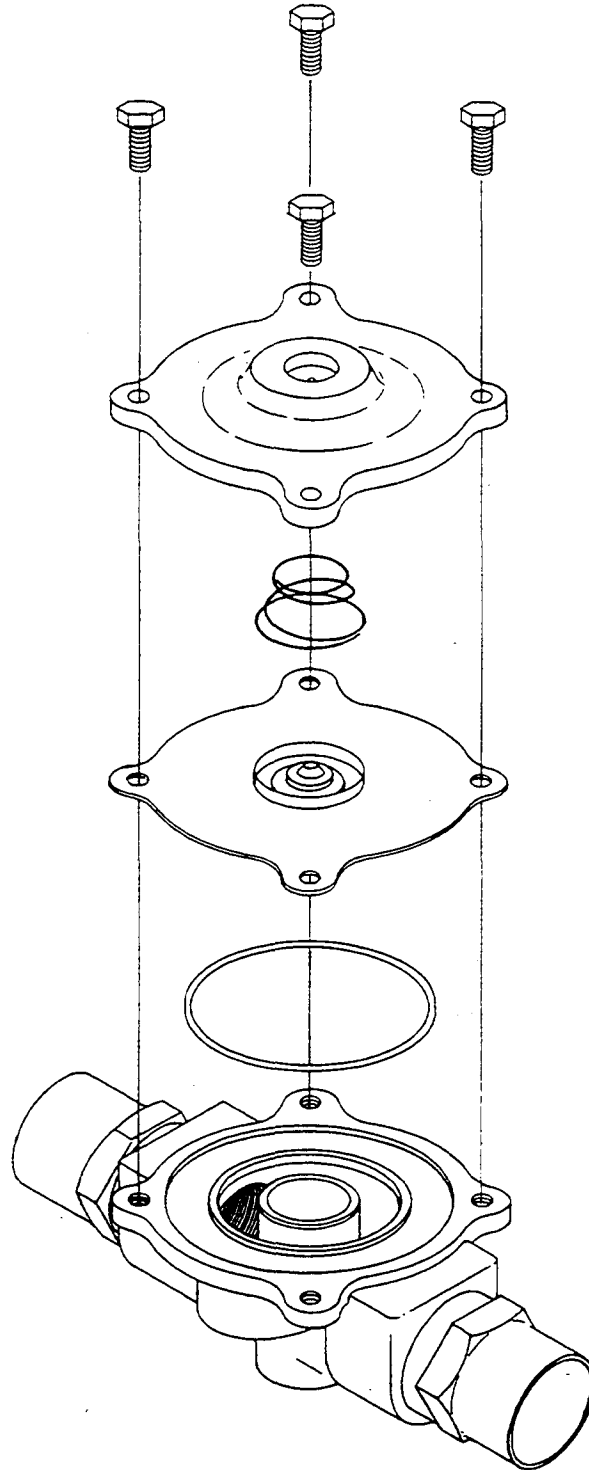

**ANTI-FOAM VALVE 3/4"
ASSEMBLY P/N 0185500
DIAPHRAGM KIT 0185501**

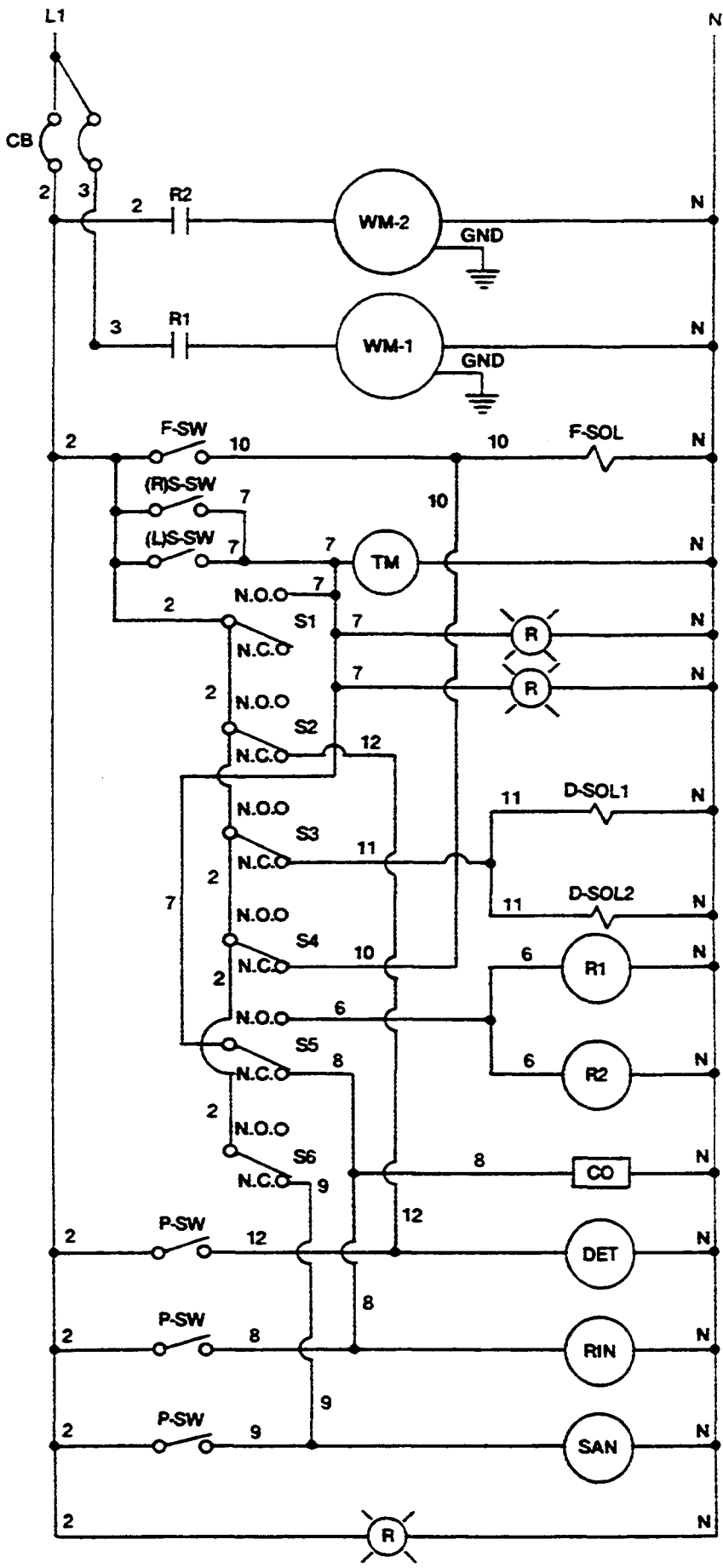

**CONSERVER II
SINGLE PHASE
115 VOLTS**

CONSERVER PARTS LIST

Part Number	Description	Number Used
0001201	110V Power Supply Decal	
0001202	Warning Decal	
0001203	Clean Strainer Decal	
0001204	Door Caution Decal	
0001208	Full & Start Switch Decal	
0001209	LH Start Switch Decal	
0001210	Operations Decal	
0001211	Timer Decal	
0008200	Cantilever Mounting Brackets	2
0008400	Cantilever Handle Grips	2
0008600	Cantilever Arm ONLY	1
0008700	Cantilever Spring Rods	2
0009000	Cantilever Springs	2
0009100	Cantilever Yoke Assembly	2
0009400	Cantilever Eye Bolts	2
0009600	Cantilever Nuts, for Eye Bolts	2
0010000	Cantilever Sleeve	2
0010300	Cantilever Bolt for Sleeve 1/4" x 1 3/8"	2
0010600	Cantilever Washer Flat, for Sleeve Bolt 1/4"	2
0010900	Cantilever Acorn Nut, for Sleeve Bolt 1/4"	2
0011200	Cantilever Lock Washer, for Sleeve Bolt 1/4"	2
0011500	Cantilever Door Coupler, to Cantilever	2
0011600	Cantilever Block, to Door	2
0012000	Circuit Breaker , 15AMP	1
0020800	Control/Dispenser Box , Completely wired	1
0029700	Control Dispenser Box Cover, w/out lock	1
0029800	Control/Dispenser Box Lock Only, w/key	1
0034000	Counter , Cycle	1
0046000	Dispenser, Peristaltic Pump Complete, 230V, 50 Cycle	
0046100	Dispenser, Peristaltic Pump Motor, 230V, 50 CYCLE	
0046500	Dispenser , Peristaltic Pump Complete	3
0046501	Dispenser, Peristaltic Pump Motor	3
0046502	Dispenser, Peristaltic Pump Housing	3
0046503	Dispenser, Peristaltic Pump Housing Mounting Bolts, 10/32" Fillster Head (3)	12
0046504	Dispenser, Peristaltic Pump Cam Roller Assembly	3
0046505	Dispenser, Peristaltic Pump Cam Roller Set Screw	3
0046506	Dispenser, Peristaltic Pump Hose	3
0046507	Dispenser, Peristaltic Pump Hose Clamp (2)	6
0046508	Dispenser, Peristaltic Pump Face Place	3
0046509	Dispenser, Peristaltic Pump Face Plate Mounting Screws, 8/32" (4)	12
0046512	Dispenser, Intake Tubing Stiffeners	3
0048001	Door, Side	2
0049000	Door Spacer, Side	
0049500	Door Screw, for Spacer 1/4" 20x1 3/8"	
0049600	Door Stop w/nut and Bolt N/S	
0051000	Door, Handle for Lid	1
0051800	Door, Nylatron Guides	4
0052200	Door Strip s/s Glue, Tube	
0053810	Drain Ball	2
0053811	Drain Stem	2
0053812	Drain Stopper Seat Plate	2
0053813	Drain Stopper Ball & Stem	2
0054100	Drain, Assembly Complete	2
0054101	Drain, Bolt, Chain to Stopper	2
0054102	Drain, Stopper Chain	2
0054103	Drain, Link Spring	2
0054104	Drain, Bolts, Solenoid to Plate (4)	8
0054105	Drain, Solenoid Coil Straps	8
0054106	Drain, Solenoid Coil, 115V	2
0054107	Drain, Adjusting Lever	2
0054108	Drain, Mounting Plate	2
0054109	Drain, Cotter Pins (2)	4
0054110	Drain, Link	2
0054111	Drain, Link Slotted Washers (2)	4

CONSERVER PARTS LIST

Part Number	Description	Number Used
0054114	Drain, Solenoid Cover	1
0054116	Drain, Solenoid Coil, 220V	
0054212	Drain, Housing LH	2
0054218	Drain, Housing R/H	
0054201	Drain, Housing Gasket Upper	2
0054202	Drain, Housing Gasket, Lower	2
0054203	Drain, Tee-Sump	2
0054204	Drain Housing, Single Drain N/S Special Units	
0054205	Drain Housing, Gasket, Upper, Single Drain N/S	
0083500	Light, Indicator	2
0086900	Pump Motor, 1 HP, 2850 RPM, 220V, 1 phase, 50 cycle	
0087000	Pump & Motor Assembly Complete 1 HP, 3450 RPM, 115V, 1 phase, 60 cycle	2
0087001	Pump, Motor, 115V, 1 HP, 3450 RPM	2
0087002	Pump, Motor Shaft Deflector	2
0087003	Pump, Housing to Flange Cap Screw (8)	16
0087004	Pump, Housing to Motor Cap Screw (4)	8
0087005	Pump, Housing	2
0087006	Pump, Ceramic Face for Seal	2
0087007	Pump, Mechanical Seal	2
0087008	Pump, Impeller	2
0087009	Pump, Impeller Nut	2
0087010	Pump, Flange Gasket	2
0087012	Pump, Flange Petcock	2
0087100	Pump & Motor Mounting Plate	2
0122600	Relay, Mercury	2
0122700	Relay, Mercury, 220V	
0143000	Solenoid Valve, 3/4", 220V, J E	
0143400	Solenoid Valve, J E, 3/4", 110V	2
0143500	Solenoid Valve Coil, J E, 110V	2
0145500	Solenoid Valve Diaphragm Cartridge and 'O' Ring, 3/4" J E	2
0148000	Solenoid Valve 'O' Ring, 3/4" J E	
0148500	Solenoid Valve Plunger Assembly, for 1/2" and 3/4" J E	
0150000	Solenoid Valve Strainer Screen, 3/4" J E	
0150100	Solenoid Valve Gasket 3/4" J E	
0152100	Strainer, Pump/Drain Line	2
0152300	Strainer, Pump/Drain Line, Single Drain, N/S	
0153700	Strainer, Y 3/4"	1
0154300	Switch, Primer, Drain, Rocker Type	5
0165500	Terminal Board, 3 Pole, Complete	
0169000	Thermometer, Rigid Stem	1
0171100	Timer, 110V w/ wires. Adjustable, 6 Cams	1
0173100	Timer Motor, 110V Single Cycle	1
0173200	Timer, w/ wires Single Cycle, 220V, 50 Cycle	
0177600	Timer Micro Switch	6
0179500	Track Assembly Complete	1
0184301	Vacuum Breaker, 3/4" Conbraco	1
0184400	Vacuum Breaker, 3/4" Conbraco Repair Kit	1
0185000	Valve, 1/4" for Health Inspectors Gauge	
0185500	Valve, Anti-Foam, 3/4"	
0185501	Valve Anti-Foam Diaphragm Kit	
0199400	Wash/Rinse Head Assembly N/S	
0199401	Wash/Rinse Head Tube & Hub Assembly	
0199402	Wash/Rinse Head Bearing Spindle N/S	
0199403	Wash/Rinse Head Retaining Ring S/S	
0199404	Wash/Rinse Head Bearing N/S	2
0199500	Wash/Rinse Head Assembly Comp	4
0199501	Wash/Rinse Head End Plugs	8
0199502	Wash/Rinse Head Vee Jets	32
0199503	Wash/Rinse Head Tube	8
0199504	Wash/Rinse Head Bearing & Shaft Assembly	4
0199505	Wash/Rinse Head Thumb Screws	8
0199506	Wash/Rinse Head Adaptor Riser	2
0199600	Wash/ Rinse Head Manifold	2
0199601	Wash/Rinse Head Manifold Gasket	2
0199612	Wash/Rinse Head Manifold; Left	1
0199613	Wash/Rinse Head Manifold; Right	1