

WHITE[®]

OPERATOR'S MANUAL

YARD BOSS 950 CHIPPER-VACUUM

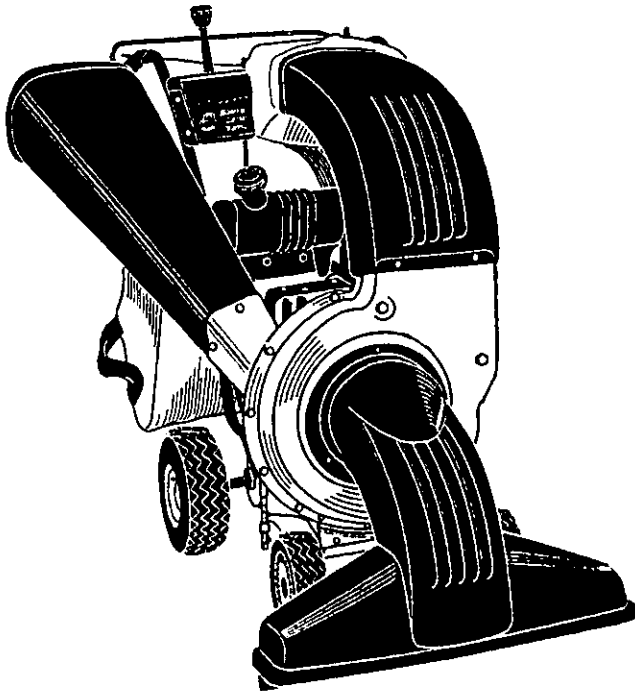

IMPORTANT: READ SAFETY RULES AND INSTRUCTIONS CAREFULLY

Warning: This unit is equipped with an internal combustion engine and should not be used on or near any unimproved forest-covered, brush-covered or grass-covered land unless the engine's exhaust system is equipped with a spark arrester meeting applicable local or state laws (if any). If a spark arrester is used, it should be maintained in effective working order by the operator. In the State of California the above is required by law (Section 4442 of the California Public Resources Code). Other states may have similar laws. Federal laws apply on federal lands. A spark arrester for the muffler is available through your nearest engine authorized service dealer or contact the service department, P.O. Box 361131 Cleveland, Ohio 44136-9722.

WHITE OUTDOOR PRODUCTS COMPANY P.O. BOX 361131 CLEVELAND, OHIO 44136-9722

PRINTED IN U.S.A.

FORM NO. 770-10052A
(5/99)

SECTION 1: IMPORTANT SAFE OPERATION PRACTICES



WARNING: THIS SYMBOL POINTS OUT IMPORTANT SAFETY INSTRUCTIONS WHICH, IF NOT FOLLOWED, COULD ENDANGER THE PERSONAL SAFETY AND/OR PROPERTY OF YOURSELF AND OTHERS. READ AND FOLLOW ALL INSTRUCTIONS IN THIS MANUAL BEFORE ATTEMPTING TO OPERATE YOUR CHIPPER-VACUUM. **FAILURE TO COMPLY WITH THESE INSTRUCTIONS MAY RESULT IN PERSONAL INJURY. WHEN YOU SEE THIS SYMBOL-HEED ITS WARNING.**



WARNING: The Engine Exhaust from this product contains chemicals known to the State of California to cause cancer, birth defects or other reproductive harm.



DANGER: Your chipper-vacuum was built to be operated according to the rules for safe operation in this manual. As with any type of power equipment, carelessness or error on the part of the operator can result in serious injury. This unit is capable of amputating fingers and hands and throwing objects. Failure to observe the following safety instructions could result in serious injury or death.

1. GENERAL OPERATION

- Read this operator's manual carefully in its entirety before attempting to assemble this machine. Read, understand, and follow all instructions on the machine and in the manual(s) before operation. Be completely familiar with the controls and the proper use of the machine before operating it. Keep this manual in a safe place for future and regular reference and for ordering replacement parts.
- Your chipper-vacuum is a powerful tool, not a plaything. Therefore, exercise extreme caution at all times. Your unit has been designed to perform two jobs; to chip and vacuum vegetation found in a normal yard. Do not use it for any other purpose.
- Never allow children under 16 to operate the unit. Children 16 years and older should only operate under close parental supervision. Only responsible individuals who are familiar with these rules of safe operation should be allowed to use your unit.
- Keep the area of operation clear of all persons, particularly small children and pets. Stop the engine when they are in the vicinity of the unit.
- When feeding material into this equipment, be extremely careful that pieces of metal, rocks, bottles, cans or other foreign objects are not included. Personal injury or damage to the machine could result.
- Always wear safety glasses or safety goggles, during operation and while performing - an adjustment or repair, to protect eyes from foreign objects that may be thrown from the machine.
- Wear sturdy, rough-soled work shoes and close fitting slacks and shirt. Shirt and slacks that cover the arms and legs and steel-toed shoes are recommended. Do not wear loose fitting clothes or jewelry, and secure hair above shoulder length. They can be caught in moving parts. Never operate a unit in bare feet, sandals or sneakers. Wear gloves when feeding material in the chipper chute.
- Do not operate the unit while under the influence of alcohol or drugs.
- Do not overreach. Keep proper footing and balance at all times.
- Never place your hands or any part of your body or clothing near or under rotating parts. Keep clear of the discharge opening at all times. Never insert your hands or any part of your body or clothing into the nozzle, chipper chute or discharge opening as the rotating impeller can cause serious injury.
- If it is necessary for any reason to unclog the feed intake or discharge openings or to inspect or repair any part of the machine where a moving part can come in contact with your body or clothing, stop the machine, allow it to cool, disconnect the spark plug wire from the spark plug and move it away from the spark plug before attempting to unclog, inspect or repair.
- Never operate unit without vacuum bag and discharge chute properly affixed to unit. Large zippered end of bag must be closed to prevent objects from being blown out.
- Never operate unit without either the inlet nozzle or optional hose attachment properly affixed to unit. These devices shield the operator from accidental contact with the rotating impeller. Never attempt to convert the unit from nozzle to hose mode or vice versa with the engine running.
- Never attempt to remove or empty vacuum bag when engine is running. Shut the engine off and wait for the impeller to come to a complete stop before removing the bag. The impeller continues to rotate for a few seconds after the engine is shut off. Never place any part of the body in the impeller area until you are sure the impeller has stopped rotating.
- Keep all guards and safety devices in place and operating properly.

- Do not allow an accumulation of processed material to build up in the discharge area as this will prevent proper discharge and can result in kickback from the chipper chute.
- Keep your face and body back from chipper chute to avoid accidental bounce back of any material.
- If the cutting mechanism strikes a foreign object or if your machine should start making an unusual noise or vibration, immediately stop the engine, disconnect the spark plug wire and move the wire away from the spark plug. Allow the machine to stop and take the following steps.
 - Inspect for damage
 - Repair or replace any damaged parts.
 - Check for any loose parts and tighten to assure continued safe operation.
- Muffler and engine become hot and can cause a burn. Do not touch.
- Do not allow leaves or other debris to build up on engine's muffler. The debris could ignite and cause a fire.
- Do not operate engine if air cleaner or cover over carburetor air intake is removed, except for adjustment. Removal of such parts could create a fire hazard.
- Check and add fuel before starting the engine. Never remove gas cap or add fuel while the engine is running. Allow engine to cool at least two minutes before refueling.
- Replace gasoline cap securely and wipe off any spilled gasoline before starting the engine as it may cause a fire or explosion.
- Extinguish all cigarettes, cigars, pipes and other sources of ignition.
- Never refuel unit indoors because flammable vapors will accumulate in the area.
- Never store the machine or fuel container inside where there is an open flame or spark such as a gas hot water heater, clothes dryer or furnace.
- Never run your machine in an enclosed area as the exhaust from the engine contains carbon monoxide, which is a odorless, tasteless and deadly poisonous gas.
- To reduce fire hazard, keep engine and muffler free of leaves, grass, and other debris build-up. Clean up fuel and oil spillage. Allow unit to cool at least 5 minutes before storing.
- Before cleaning, repairing, or inspecting, make certain the impeller and all moving parts have stopped. Disconnect the spark plug wire and keep wire away from spark plug to prevent accidental starting. Do not use flammable solutions to clean air filter.

2. CHILDREN

Tragic accidents can occur if the operator is not alert to the presence of small children. Children are often attracted to the chipping and vacuuming activity. Never assume that children will remain where you last saw them.

- Keep children out of the work area and under the watchful eye of a responsible adult other than the operator.
- Be alert and turn the unit off if a child enters the area.
- Never allow children under the age of 16 to operate the chipper-vacuum.

3. SERVICE

- Use extreme care in handling gasoline and other fuels. They are extremely flammable and the vapors are explosive.
- Store fuel and oil in approved containers, away from heat and open flame, and out of the reach of children.
- Keep all nuts, bolts, and screws tight to be sure the equipment is in safe working condition.
- Never tamper with safety devices. Check their proper operation regularly.
- After striking a foreign object, immediately stop the engine, disconnect the spark plug wire from the spark plug, and thoroughly inspect the unit for any damage. Repair damage before starting and operating unit.
- Do not alter or tamper with the engine's governor setting. The governor controls the maximum safe operating speed of the engine. Overspeeding the engine is dangerous and will cause damage to the engine and to other moving parts of the machine.
- Check the vacuum bag frequently for wear. Replace if worn or damaged.
- Keep vacuum bag free of debris when not in use.



WARNING - YOUR RESPONSIBILITY: Restrict the use of this power machine to persons who read, understand and follow the warnings and instructions in this manual and on the machine.

SECTION 2: SAFETY LABELS FOUND ON YOUR UNIT.

ROTATING BLADES INSIDE. KEEP HANDS AWAY FROM ALL OPENINGS. DO NOT REMOVE OR ATTACH NOZZLE OR OPTIONAL HOSE KIT WHEN ENGINE IS RUNNING!
S30183

DANGER

ROTATING CUTTING BLADES.
KEEP HANDS AND FEET OUT
OF OPENINGS WHILE MACHINE
IS RUNNING.

S30181

DO NOT OPERATE THIS UNIT WITHOUT
ENTIRE BAG AND DISCHARGE CHUTE
IN PLACE. TURN THE ENGINE OFF AND
ALLOW THE IMPELLER TO COME TO A
COMPLETE STOP BEFORE REMOVING
THE BAG.

S30131

WARNING

TO AVOID SERIOUS INJURY

- Read Owner's Manual and all safety labels on machine before starting and using machine.
- Keep hands, feet, face, long hair and clothing out of chipper inlet, vac inlet, and discharge area. There are ROTATING BLADES inside these openings.
- Wear approved safety glasses and gloves. Avoid loose fitting clothes.
- Keep the area of operation clear of all persons, particularly small children and pets.
- Keep all shields and guards (e.g. upper chipper chute extension, discharge chute, nozzle assembly) in place and securely attached.
- Check bag frequently for wear. Replace if worn or damaged.
- If unit becomes clogged or jammed, shut off engine right away. Do not attempt to clear clog or jam with engine running. Refer to Maintenance Section of Owner's Manual for unclogging instructions.
- Muffler and engine get hot and can cause burns. Do not touch. To avoid a fire hazard, keep leaves, grass, and other combustible debris off hot muffler and engine.
- Do not attempt to remove or attach vac nozzle or optional Hose Kit with engine running. Do not operate unit unless nozzle or optional Hose Kit is secured in place.
- Do not fill gas tank while engine is running. Allow engine to cool at least 2 minutes before re-fueling.

SECTION 3: FINDING YOUR MODEL NUMBER

This Operator's Manual is an important part of your new chipper-vacuum. It will help you assemble, prepare and maintain your chipper-vacuum. Please read and understand what it says.

Before you prepare your chipper-vacuum for its first use, please locate the model plate and copy the information from it in this Operator's Manual. The information on the model plate is very important if you need help from your dealer or the Customer Support Department.

- Every chipper-vacuum has a model plate. You can locate it by standing behind the unit in the operating position and looking down at the frame just below the engine.
- The model plate will look like this.

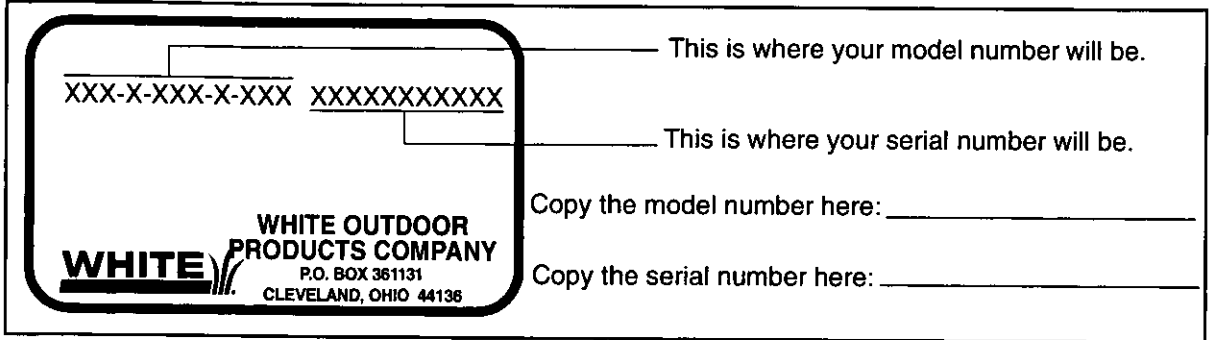

SECTION 4: CALLING WARRANTY SERVICE

If you are having difficulty assembling this product or if you have any question regarding the controls, operation or maintenance of this chipper-vacuum, please call the Customer Dealer Referral Line. You can reach them by calling:

1-800-949-4483

Before calling your local dealer, make sure that you have your model and serial numbers ready. By having the model and serial numbers ready, you help your local dealer give you faster service. To find your units model and serial number, see SECTION 3: FINDING YOUR MODEL NUMBER.

SECTION 5: ASSEMBLY INSTRUCTIONS

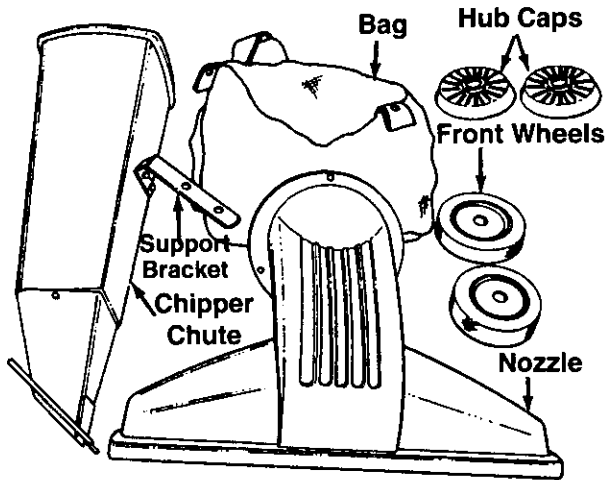

Figure 1

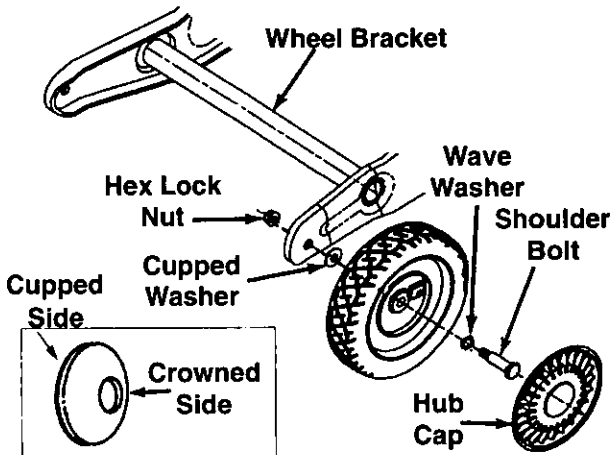

Figure 2

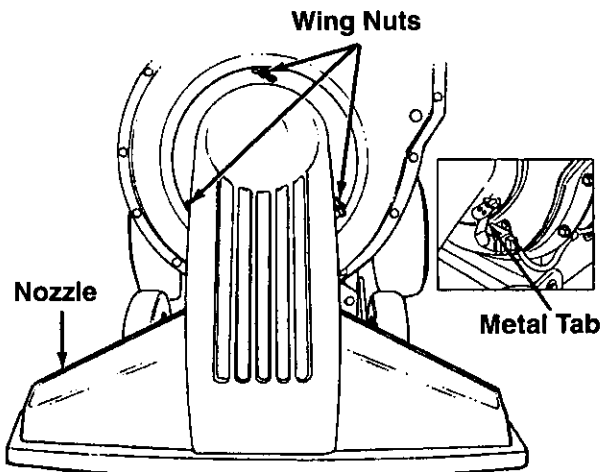

Figure 3

IMPORTANT: This unit is shipped **WITHOUT** GASOLINE or OIL in the engine. After assembly, see separate engine manual for proper fuel and engine oil recommendations.

NOTE: To determine right and left hand sides of your chipper-vacuum, stand behind and face the unit.

TO REMOVE CHIPPER-VACUUM FROM CARTON

1. Remove staples, break glue on top flaps, or cut tape at carton end and peel along top flap to open carton.
2. Remove loose parts if included with unit (i.e., operator's manual, etc.).
3. Cut corners and lay carton down flat.
4. Remove packing material.
5. Push down on handle to lift the front of the chipper-vacuum, and roll unit out of carton. Check carton thoroughly for loose parts.

TOOLS REQUIRED FOR ASSEMBLY

- (1) 3/4" Open End Wrench* (2) 1/2" Wrenches*
 (1) Funnel (1) 9/16" Wrench*
 (1) Set of Pliers (2) 7/16" Wrenches*

*Adjustable wrenches may be used.

LOOSE PARTS IN CARTON (See Figure 1)

- | | |
|---------------------|-------------------------|
| (2) Front Wheels | (1) Bag |
| (2) Hub Caps | (1) Shift Knob† |
| (1) Nozzle | (1) Tamper Plug† (Opt.) |
| (1) Chipper Chute | (1) Safety Glasses† |
| (1) Support Bracket | |
- †Not Shown

ATTACHING THE FRONT WHEELS

1. Tilt unit backward so that it rests on the handle (place a piece of the carton under handle to avoid scratches). Remove the cardboard packing material around the wheel brackets.
2. Remove the hex lock nuts and shoulder bolts from the front of the wheel brackets. See Figure 2.
3. Place wave washer on shoulder bolt. Insert shoulder bolt through wheel, with the head of the shoulder bolt through the flat side of the wheel.
4. Place cupped washer on shoulder bolt (crowned side of washer goes against the wheel).
5. Assemble wheel to outside of wheel bracket. Secure hex lock nut. Tighten.
6. Attach hub caps to wheels by placing in position against the inner hub of the wheel. Press firmly around the center portion of hub cap in a circular motion, similar to installing a lid on a round, plastic container. The hub caps are flexible and will snap over the wheel hubs.

ATTACHING THE NOZZLE (See Figure 3)

1. Remove three wing nuts from the front of the chipper-vacuum. Place nozzle in position over the three studs. Secure with wing nuts just removed.

NOTE: The metal tab on the nozzle must depress the safety switch on the front of the chipper-vacuum or the engine will not start.

2. Set unit in upright position.

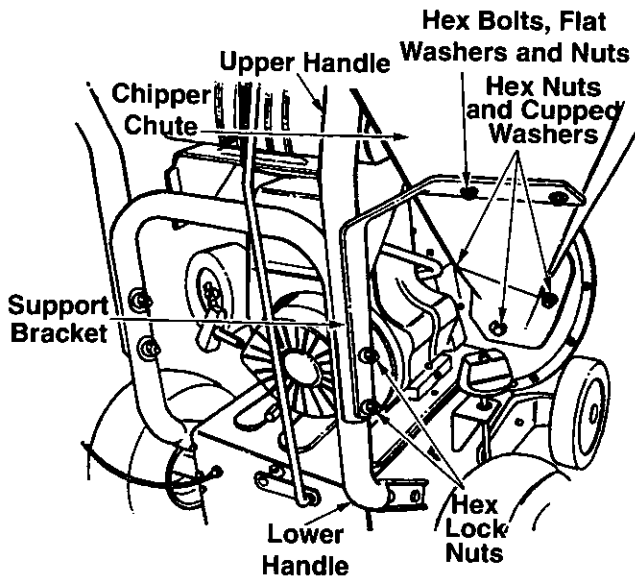

Figure 4

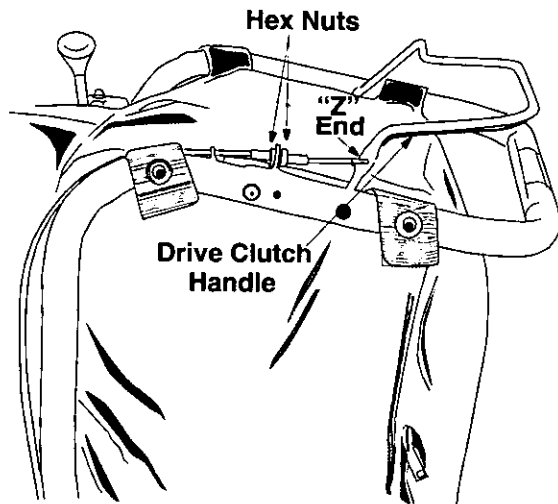

Figure 5

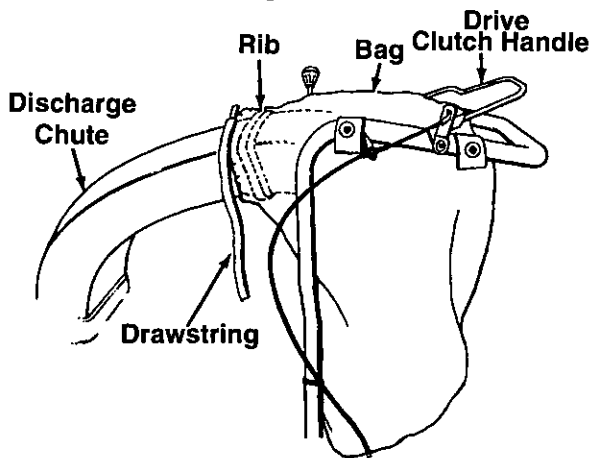

Figure 6

ATTACHING THE CHIPPER CHUTE AND SUPPORT BRACKET (See Figure 4)

1. Remove the two hex bolts, flat washers and nuts which are attached to the support bracket.
2. Attach the support bracket to the bottom of the chipper chute loosely using the hardware removed previously. Heads of the hex bolts and washers go to the inside of the chipper chute.
3. Remove the two hex lock nuts from the hex bolts which secure the right side of the upper handle to the lower handle. Leave bolts and washers in place.
4. Remove three cupped washers and 5/16" hex nuts from the weld studs beside the opening on the right side of the chipper-vacuum.
5. Place the chipper chute in position over the weld studs (slot goes at the bottom). Secure with cupped washers and hex nuts just removed. Only tighten the three nuts one or two threads for ease of further assembly.

NOTE: Cupped side of the washer goes against the chipper chute. See Figure 2 to identify cupped side of washer.

6. Place the support bracket over the two bolts in the handle. Pushing UP on the chipper chute will aid the alignment of the holes in the support bracket with the bolts in the handle.
7. Tighten all hardware securely on the chipper chute, support bracket and handle.

ATTACHING THE CLUTCH CABLE

The clutch cable has been partially assembled at the factory. You will have to attach the clutch cable, to the handle.

1. Loosen the hex nuts at the cable bracket and back the bottom hex nut all the way down.
2. Holding the drive clutch handle up, hook the "Z" end of the cable into the drive clutch handle from the outside to the inside. See Figure 5. Pliers will aid in assembly.

CLUTCH CABLE ADJUSTMENT

Adjust the hex nuts at the cable bracket so there is no slack in the cable, but the **cable is NOT tight**. Do not overtighten the cable. See Figure 5.

To check the clutch adjustment, proceed as follows.

1. Push the chipper-vacuum backward and forward with the drive clutch handle released. It should move freely.
2. If it does not, loosen both hex nuts at the cable bracket. See Figure 5. Turn bottom nut clockwise to loosen the cable.
3. Engage the drive clutch handle (hold against upper handle), and try to push chipper-vacuum backward and forward. The wheels should lock up.
4. If the wheels do not lock up, loosen both hex nuts at the cable bracket. Turn bottom nut counterclockwise to tighten the cable.
5. Recheck adjustment. Tighten both hex nuts when correct adjustment is reached.

ATTACHING THE BAG

1. Place bag inside of handle assembly. Slip the opening on the bag over the discharge chute, making certain it is over the rib on the discharge chute. See Figure 6.
2. Place the four straps on the top of the bag over upper handle, hooking them on studs. See Figure 7. Be sure the bag goes **under** the drive clutch handle.
3. Squeeze the clamp on the drawstring, and pull the drawstring tight. Release the clamp.

INSTALLING THE SHIFT KNOB

Thread the shift knob onto the end of the shift lever.

TAMPER PLUG (IF EQUIPPED)

The handle on the tamper plug must be in the vertical position as shown in Figure 8. To determine which side of the tamper plug is up, match the angle of the tamper plug to the angle of the chipper chute. Insert the tamper plug into the chipper chute.

NOTE: *Tamper plug should remain in the chipper chute whenever the chipper chute is not in use.*

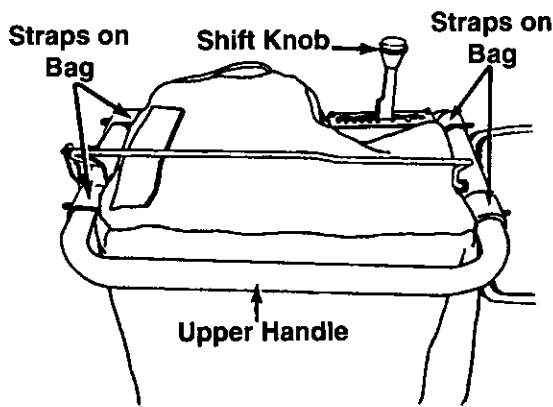

Figure 7

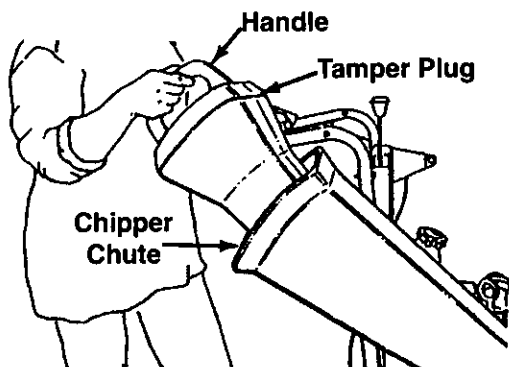

Figure 8

SECTION 6: OPERATION

BEFORE USING YOUR CHIPPER-VACUUM, REFER TO THE "SAFETY RULES" AS SHOWN ON PAGES 2 AND 3 OF THIS MANUAL. ALWAYS BE CAREFUL.



The operation of any chipper-vacuum can result in foreign objects being thrown into the eyes, which can damage your eyes severely. **Always wear the safety glasses provided with this unit or eye shields before chipping, or while performing any adjustments or repairs.** We recommend Wide Vision Safety Mask for over spectacles or standard glasses.

CONTROLS (See Figure 9)

SHIFT LEVER—The shift lever determines ground speed of your unit. It may be placed in one of eight positions. Of these eight, six positions are to go forward, and two positions are to go in reverse.

Forward—one of six speeds. Position number one (1) is the slowest. Position number six (6) is the fastest.

Reverse—two reverse (R) speeds. "R" (all the way to the right) is the faster of the two.

DRIVE CLUTCH HANDLE

Squeezing the drive clutch handle against the upper handle engages the wheel drive. Release the drive clutch handle to stop the wheel drive.

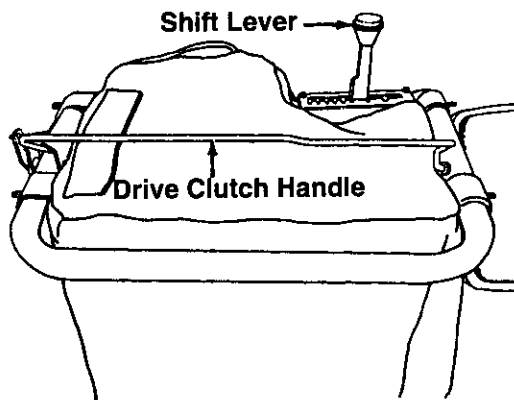

Figure 9

GAS AND OIL FILL-UP

Service the engine with gasoline and oil as instructed in the separate engine manual packed with your chipper-vacuum. **Read instructions carefully.**

NOTE: Your chipper-vacuum is shipped without oil; however, a small amount of oil may be present from the factory. Do not overfill.



WARNING: Never fill fuel tank indoors, with engine running or while engine is hot. Do not smoke when filling fuel tank.

TO START ENGINE

IMPORTANT: If unit shows any sign of motion with the clutch handle disengaged, shut engine off immediately. Readjust as instructed in the "Clutch Cable Adjustment" section of the Assembly Instructions.



WARNING: Be sure no one other than the operator is standing near the chipper-vacuum while starting or operating. Do not operate this chipper-vacuum unless the nozzle, discharge chute and bag have been properly installed.

NOTE: Your chipper-vacuum unit has a safety switch at the front of the housing. The nozzle or optional hose attachment must be in place on the chipper-vacuum before the engine can be started.

1. Attach spark plug wire to spark plug.
2. Make certain drive clutch handle is in the disengaged (released) position.
3. **Engines with choke lever:** Move choke lever on engine to CHOKE position. (A warm engine may not require choking.)
Engines with primer: Prime engine as instructed in separate engine manual.
4. Move throttle control lever on engine to FAST position.
5. Place one foot on the left rear wheel to prevent the unit from skidding while starting.
6. Grasp starter handle and pull rope out slowly until engine reaches start of compression cycle (rope will pull slightly harder at this point). Let the rope rewind slowly.

NOTE: A noise will be heard when finding the start of the compression cycle. This noise is caused by the flails and fingers which are part of the shredding mechanism falling into place, and should be expected. In addition, the flails and fingers will be noisy after the engine is started, until the impeller reaches full speed.

7. Pull rope with a rapid, continuous, full arm stroke. Keep a firm grip on starter handle. Let rope rewind slowly. Do not let starter handle snap back against starter.

8. Repeat instructions 6 and 7 until engine fires. When engine starts, move choke control (if so equipped) gradually to RUN position.

TO STOP ENGINE

1. To stop engine, move throttle control lever to OFF position.
2. Disconnect spark plug wire and ground to prevent accidental starting while equipment is unattended.

TO EMPTY BAG

Open the large zipper on the bag to empty the bag. See Figure 10. **Be certain the zipper is closed when operating the unit.**

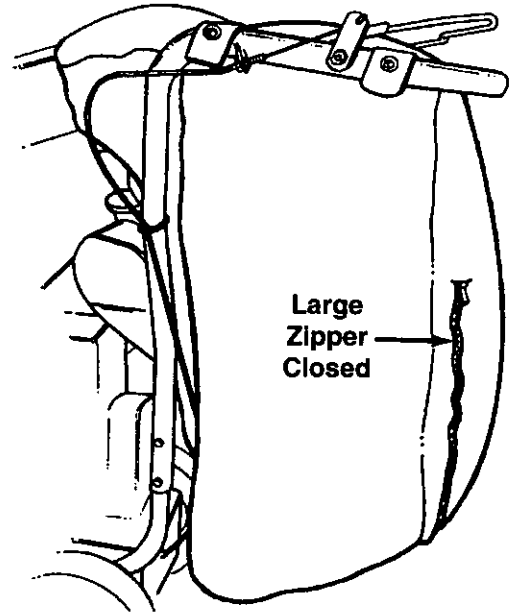

Figure 10

TO ENGAGE DRIVE

IMPORTANT: Always release the drive clutch handle before moving the shift lever.

With the engine running at top speed, move shift lever into one of the six FORWARD positions or two REVERSE positions. Select a speed appropriate for the conditions that exist. Use the slower speeds until you are familiar with the operation of the chipper-vacuum.

To engage the wheel drive, hold the drive clutch handle against the chipper-vacuum handle. Releasing the drive clutch handle stops the wheels from driving. Release the drive clutch handle to slow down when negotiating an obstacle, making a turn or stopping. Engage slowly to prevent front wheels from lifting up.

HOW TO USE THE CHIPPER

Do not attempt to shred or chip any material other than vegetation found in a normal yard (i.e., branches, leaves, twigs, etc.). Material such as stalks or heavy branches up to 3" in diameter may be fed into the chipper chute. See Figure 11.



WARNING: Material up to a maximum of 3" in diameter may be fed into the chipper chute. Do not attempt to shred or chip any material larger than 3" in diameter. Personal injury or damage to the machine could result.

Use the tamper plug (if so equipped) to push material into the chipper chute. See Figure 8. **NEVER PLACE HANDS INSIDE CHIPPER CHUTE.** Place tamper plug inside chipper chute when not in use to deaden the sound.

IMPORTANT: There is a flail screen located inside the housing in the discharge area. If the flail screen becomes clogged, remove and clean as instructed in the Maintenance section on page 11. For best performance, it is important to keep the chipper blades sharp. Refer to Maintenance section, page 11. If the composition of the material being discharged changes (becomes stringy, etc.) or if the rate at which the material is discharged slows down considerably, it is likely that the chipper blades are dull and need to be sharpened or replaced.

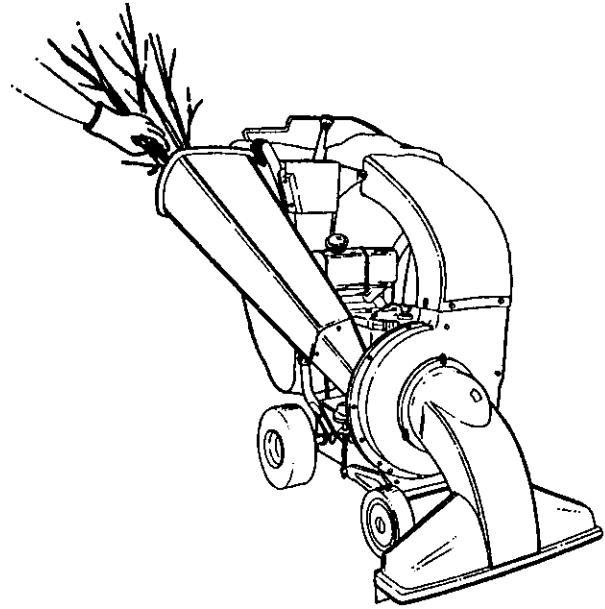

Figure 11

SECTION 7: ADJUSTMENTS



WARNING: Do not at any time make any adjustment to the unit without first stopping engine and disconnecting spark plug wire.

HEIGHT ADJUSTMENT

The height adjustment knob is located on the right hand side of the chipper-vacuum. See figure 12. Turn the knob clockwise to raise the nozzle. Turn the knob counterclockwise to lower. (Be careful not to turn knob too far—rod could come out of ferrule.)

The best height for the nozzle will vary according to the conditions. Adjust the height of the nozzle to find the setting which gives the best performance for the operating conditions. In general, raise the nozzle to vacuum a thick layer of leaves; lower the nozzle for smooth surfaces.

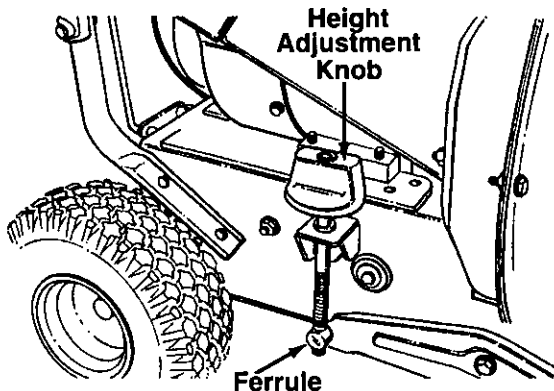

Figure 12

CARBURETOR ADJUSTMENT



WARNING: If any adjustments are made to the engine while the engine is running (e.g., carburetor), keep clear of all moving parts. Be careful of heated surfaces and muffler.

Minor carburetor adjustment may be required to compensate for differences in fuel, temperature, altitude or load. Do not make unnecessary adjustments. Factory settings are satisfactory for most applications and conditions. If adjustment is needed, refer to the separate engine manual packed with your chipper-vacuum.

NOTE: A dirty air cleaner will cause engine to run rough. Be certain air cleaner is clean and attached to the carburetor before adjusting carburetor.

CLUTCH CABLE ADJUSTMENT

To adjust the clutch cable, refer to the "Clutch Cable Adjustment" section of Assembly Instructions.

SHIFT ROD ADJUSTMENT

If the shift rod needs adjustment to obtain forward or reverse correctly, proceed as follows. See Figure 13.

1. Remove the bag from the unit.
2. Remove the hairpin clip and flat washer from the upper end of the shift rod. Pull the ferrule out of the hole in the shift lever. (Make certain wave washer remains in place on the ferrule.)
3. Place the shift lever in 6th position (all the way to the left).
4. Push down on the shift rod. Thread the ferrule up or down the shift rod until the ferrule lines up with the upper hole in the shift lever.
5. Secure ferrule to shift lever with flat washer and hairpin clip.

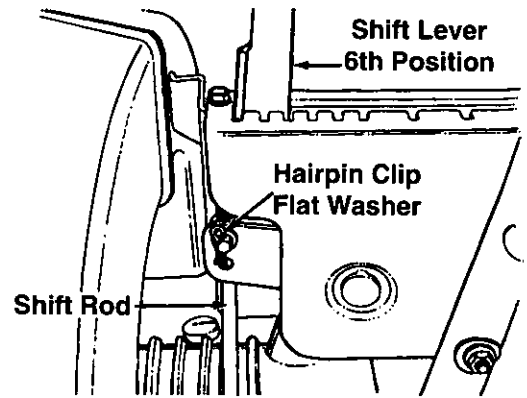

Figure 13

SECTION 8: MAINTENANCE



WARNING: Always stop engine and disconnect spark plug wire before cleaning, lubricating or performing any repairs or maintenance.

LUBRICATION

Wheels—Rear wheels are provided with light oil bearings. Place a few drops of SAE 30 oil on each bearing once a season.

Height Adjustment Mechanism—Lubricate the pivot points on the height adjustment mechanism once a season using a light oil.

CLEANING

Clean the chipper-vacuum thoroughly after each use. Wash the bag periodically with water. Allow to dry thoroughly in the shade. Do not use heat.

ENGINE

Refer to the separate engine manual for engine maintenance instructions.

REMOVING THE FLAIL SCREEN

If the discharge area becomes clogged, remove the flail screen and clean area as follows.

1. Stop the engine. Make certain the chipper-vacuum has come to a complete stop. Disconnect the spark plug wire before unclogging the discharge chute.
2. Remove the vacuum bag from the unit.
3. Remove the four self-tapping screws from the bottom of the discharge chute, and the hex bolt, flat washer and hex nut from the top. Remove the discharge chute assembly. See Figure 14.
4. Remove the two hex bolts and hex nuts which extend through the housing. Lift the flail screen from inside the housing. See Figure 15.
5. Clean the screen by scraping or washing with water. Reinstall the screen.

NOTE: Be certain to reassemble the flail screen with the curved side down as shown in Figure 15.

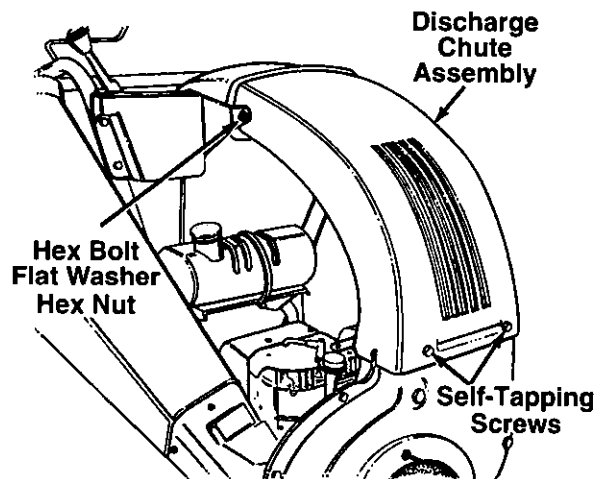

Figure 14

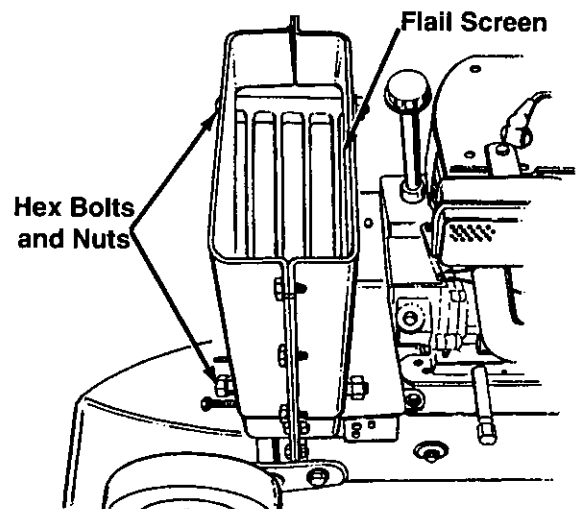

Figure 15

SHARPENING OR REPLACING CHIPPER BLADES

1. Disconnect the spark plug wire and move away from the spark plug.
2. Remove the flail screen as instructed in the previous section.
3. Remove the plastic belt cover on the front of the engine by removing the two self-tapping screws. See Figure 16.

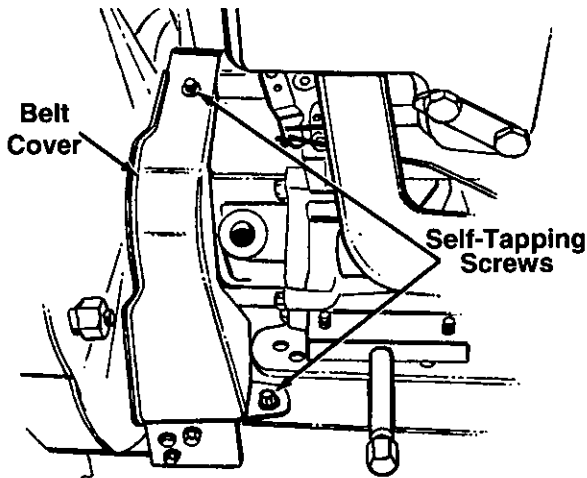

Figure 16

4. Remove the access plate by removing two hex lock nuts. See Figure 17.

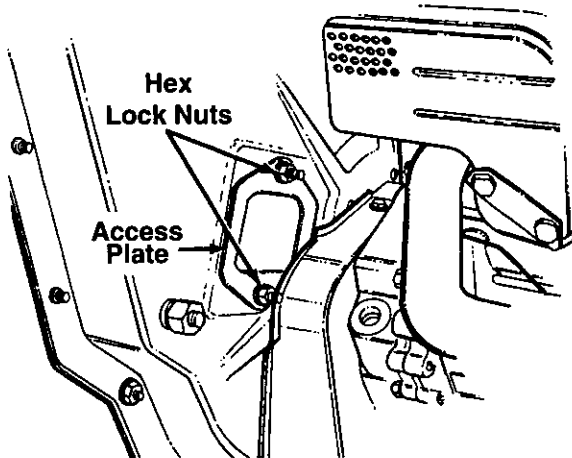

Figure 17

5. Locate one of the chipper blades in the access plate opening by rotating the impeller assembly by hand. Remove the blade using a 3/16" allen wrench on the outside of the blade and 1/2" wrench on the impeller assembly, inside the housing. Torque hardware to 250-300 inch pounds.
6. Remove the other blade in the same manner. Replace or sharpen blades. If sharpening, make certain to remove an equal amount from each blade. Reassemble in reverse order.

NOTE: Make certain blades are reassembled with the sharp edge facing upward, as viewed from the access plate opening.

CHANGING THE FRICTION WHEEL RUBBER

The rubber on the friction wheel is subject to wear and should be checked after 50 hours of operation, and periodically thereafter. Replace friction wheel rubber if any signs of wear or cracking are found.

1. Drain the gasoline and oil from the chipper-vacuum.
2. Tip the unit backward so it rests on the handles.
3. Remove the frame cover by removing eight self-tapping screws from underneath the chipper-vacuum. See Figure 18.
4. Remove the hex shaft from the unit by removing the hex bolts, lock washers and flat washers from each side of the frame. See Figure 19. Hold the friction wheel assembly, and slide the hex shaft out of the unit toward the right side.
5. Remove the six screws from the friction wheel assembly (three from each side). Remove the friction wheel rubber from between the friction wheel plate.
6. Reassemble new friction wheel rubber to the friction wheel assembly, tightening the six screws in rotation and with equal force.
7. Slide the friction wheel assembly up onto the shift mechanism, then slide the hex shaft back into the unit. Reassemble in reverse order.
8. Readjust the clutch cable. Refer to adjustment section.

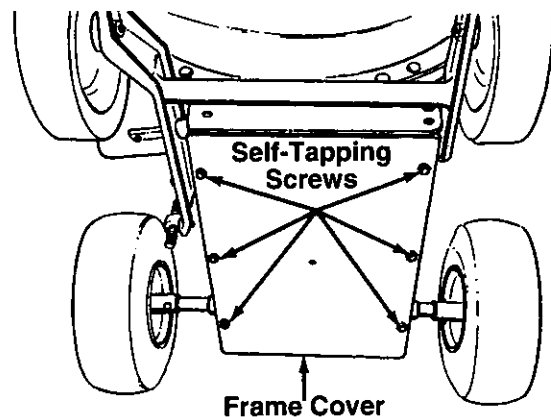

Figure 18

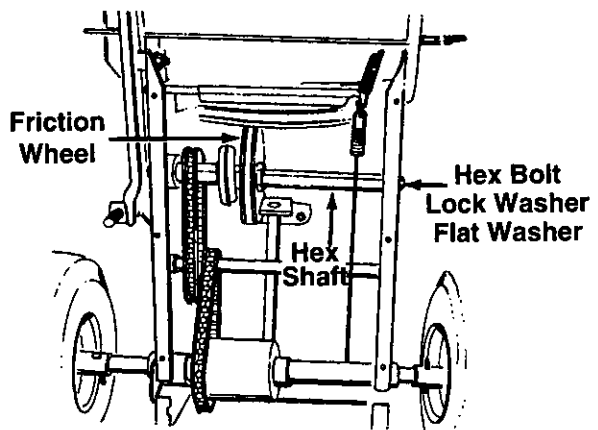

Figure 19

BELT REMOVAL AND REPLACEMENT



WARNING: Disconnect the spark plug wire and move away from the spark plug.

1. Remove the plastic belt cover on the front of the engine by removing two self-tapping screws. Refer to Figure 16.
2. Drain the gasoline and oil from the chipper-vacuum.
3. Tip the unit backward so that it rests on the handles.
4. Remove the frame cover by removing eight self-tapping screws from underneath the chipper-vacuum. Refer to Figure 18.
5. Remove the idler pulley bracket as follows. (See Figure 20.)
 - a. Take the tension off the belt by pivoting the idler pulley toward you, and line up the holes in the idler bracket assembly. Insert a nail or similar object through the holes to hold the idler pulley in this position.
 - b. Remove three self-tapping screws, and lift off the idler bracket assembly.

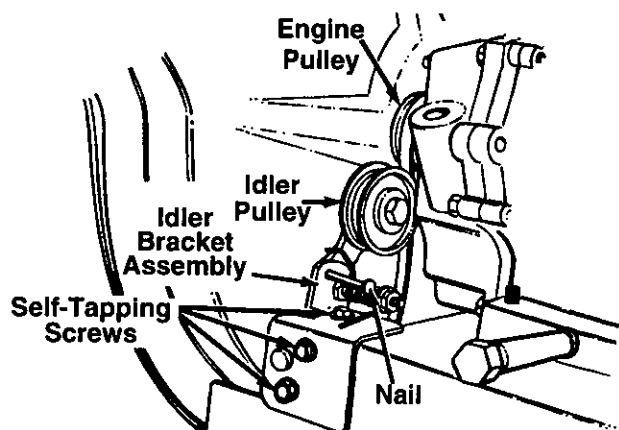

Figure 20

6. Remove the hex bolt and lock washer from the engine pulley. See Figure 20. Slip the engine pulley off the engine shaft, and remove the belt from the pulley.
7. Loosen the nut on the stop bolt until there is clearance between the support bracket and the friction wheel disc. See Figure 21.
8. Slip the belt between the friction wheel and friction wheel disc. Remove and replace belt. Reassemble following instruction in reverse order.

NOTE: The support bracket must rest on the stop bolt after the new belt has been assembled.

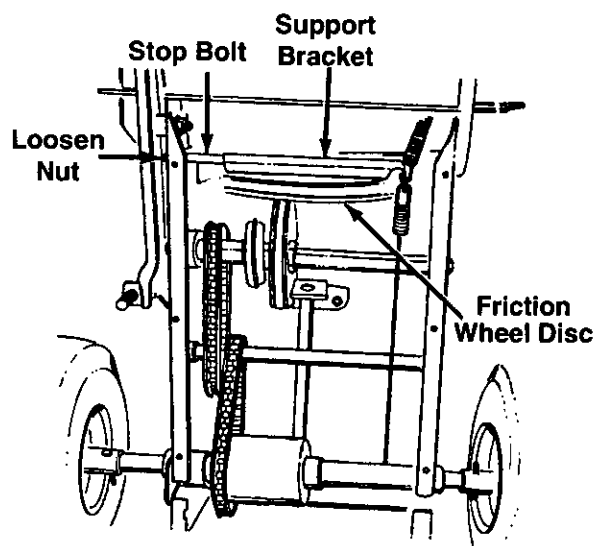

Figure 21

SECTION 9: OFF-SEASON STORAGE

The following steps should be taken to prepare your chipper-vacuum for storage.

1. Remove all dirt from exterior of engine and equipment.
2. Refer to engine manual for correct engine storage instructions.
3. Wipe unit with an oiled rag to prevent rust (use a light oil or silicone), especially if storing in an unventilated or metal storage shed.
4. Store in a dry, clean area. Do not store next to corrosive materials, such as fertilizer.

SECTION 10: TROUBLE SHOOTING GUIDE

Trouble	Possible Cause(s)	Corrective Action
Engine fails to start	Dirty aircleaner. Fuel tank empty or stale fuel. Spark plug wire disconnected. Cannot pull recoil cord. Choke not in ON position. Faulty spark plug. Nozzle safety switch not depressed.	Refer to the engine manual packed with your unit. Fill tank with clean, fresh gasoline. Fuel will not last over thirty days unless a fuel stabilizer is added. Connect wire to spark plug. Obstruction lodged in impeller. Stop immediately and disconnect spark plug wire. Remove lodged object. Move switch to ON position. Clean, adjust gap or replace. Adjust metal tab so it depresses the safety switch.
Loss of power; operation erratic	Spark plug wire loose. Unit running on CHOKE. Blocked fuel line or stale fuel. Water or dirt in fuel system. Carburetor out of adjustment. Low engine RPM. Dirty air cleaner.	Connect and tighten spark plug wire. Move choke lever to OFF position. Clean fuel line; fill tank with clean fresh gasoline. Fuel will not last over thirty days unless a fuel stabilizer is used. Disconnect fuel line at carburetor to drain fuel tank. Refill with fresh fuel. Refer to the engine manual packed with your unit. Always run engine at full throttle. Refer to the engine manual packed with your unit.
Engine overheats	Carburetor not adjusted properly. Dirty aircleaner. Engine oil level low.	Refer to the engine manual packed with your unit. Refer to the engine manual packed with your unit. Fill crankcase with proper oil.
Too much vibration	Loose parts or damaged impeller.	Stop engine immediately and disconnect spark plug wire. Have unit serviced by a an authorized service dealer.
Unit does not discharge	Discharge chute clogged. Foreign object lodged in impeller. Low engine RPM. Vacuum bag is full.	Stop engine immediately and disconnect spark plug wire. Clean flail screen and inside of blower housing. See Maintenance section of this manual. Stop engine immediately and disconnect spark plug wire. Remove lodged object. Always run engine at full throttle. Empty bag.
Rate of discharge slows considerably or composition of discharged material changes	Low engine RPM. Chipper blades dull.	Always run engine at full throttle. Replace chipper blades or see your authorized service dealer.

Note: For repairs beyond the minor adjustments above, contact your local authorized service dealer.

SECTION 11: ILLUSTRATED PARTS

YARD BOSS 950

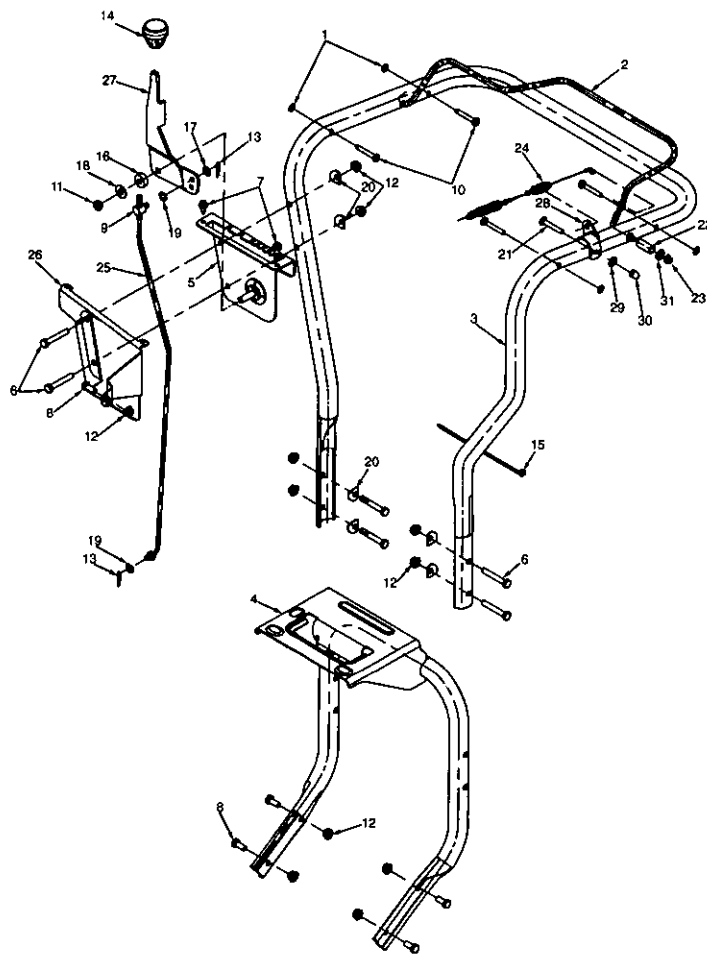

REF. NO.	PART NUMBER	DESCRIPTION	QTY	REF. NO.	PART NUMBER	DESCRIPTION	QTY
1	1539-019	Nut, Push, .25	4	18	736-0300	Washer, Flat, .406 x .875x.059	1
2	747-1133-0662	Control Assembly, Clutch	1	19	736-0413	Washer, Spring, .390 x .62	2
3	749-1083-0662	Handle Assembly, Upper	1	20	736-0451	Washer, Saddle, .320 x .93	6
4	649-0012-0662	Handle Assembly, Lower	1	21	710-0495	Carr. Bolt 1/4-20 x 1.75" Lg.	1
5	681-0076-0662	Bracket Assembly, Shift	1	22	750-1185	Spacer	1
6	710-3103	Screw, Hex Cap, 5/16-18 x 2.0	6	23	726-0135	Nut, Cap Speed	1
7	710-0896	Screw, Hex Wash Hd, 4-14x	2	24	746-1080	Cable, Clutch	1
8	710-3008	Screw, Hex Cap 5/16-18 x .75	5	25	747-0626	Rod, Shift	1
9	711-0677	Ferrule	1	26	781-0626-0662	Cover, Shift	1
10	711-0737	Pin, Stud, .250 x 1.75	4	27	784-0297A	Handle, Shift	1
11	712-0116	Nut, Hx Ins. Jam Lk. 3/8-24Thd	1	28	781-0157	Bracket, Cable Mtg.	1
12	712-3004A	Nut, Hex Flange Lock 5/16-18	11	29	736-3020	Washer, Flat .271 x .63 x .65	1
13	714-0104	Pin, Internal Cotter	2	30	712-0442	Nut, Lock, Acorn 1/4-20	1
14	720-0232	Knob, Shift	1	31	736-0275	Washer, Flat 5/16	1
15	725-0157	Cable Tie	1				
16	735-0126	Rubber Washer	1				
17	736-0117	Washer, Flat .385 x .62 x .6	1				

YARD BOSS 950

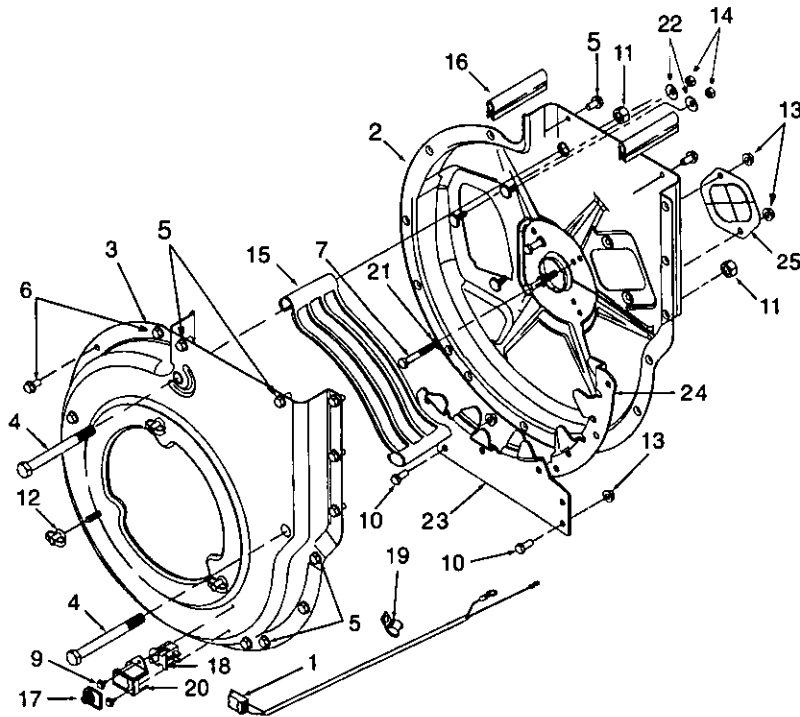

REF. NO.	PART NUMBER	DESCRIPTION	QTY.	REF. NO.	PART NUMBER	DESCRIPTION	QTY.
1	629-0241	Harness, Wire	1	14	712-3010	Nut, Hex, 5/16-18	3
2	681-0059-0662	Housing Ass'y, Inner Flail	1	15	719-0326	Screen, Discharge	1
3	681-0060-0662	Housing Ass'y, Outer Flail	1	16	723-0438	Rubber Seal	2
4	710-0382	Screw, Hex Cap, 1/2-13 x 5.0	2	17	725-1700	Cover, Switch	1
5	710-0604	Screw, Hex Wash Hd Tapp 5/16-18 x .62	10	18	725-3166	Switch, Snap Mount	1
6	710-0607	Screw, Hex Wash Hd Tapp 5/16-18 x .50	8	19	726-0272	Clamp	1
7	710-0772	Screw, Hex Cap, 5/16-24 x 2 GR5	3	20	731-1613	Cover, Safety Switch Mtg.	1
9	710-1268	Screw, Hex Wash Hd Tapp #10-16 x .38	2	21	736-0119	Washer, Lock, 5/16	3
10	710-3008	Screw, Hex Cap, 5/16-18 x .75 GR5	2	22	736-0242	Washer, Bell, .345 x .88 x .06	3
11	712-0384	Nut, Hex Center Lock, 1/2-13	2	23	781-0598	Blade, Lower Shredder	1
12	712-0421	Knob, 5/16-18	2	24	781-0599	Blade, Upper Shredder	1
13	712-3004A	Nut, Hex Flange Lock, 5/16-18	3	25	781-0627	Cover, Chipper Blade	1

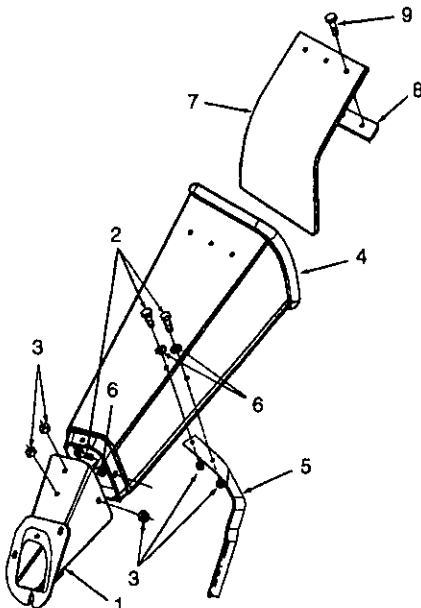

REF. NO.	PART NUMBER	DESCRIPTION	QTY.
1	681-0068-0662	Chute Assembly, Chipper	1
2	710-0751	Screw, Hex Cap, 1/4-20 x .625	5
3	712-3027	Nut, Hex Flange Lock, 1/4-20	5
4	731-1609	Chute, Chipper	1
5	781-0625-0662	Bracket, Chipper Chute Support	1
6	736-0173	Washer, Flat, .28 x .74 x .63	5
7	735-0249	Flap, Chipper Chute	1
8	781-0633	Strip, Chute Flap	1
9	728-0175	Rivet, Pop, .156 x .504	3
—	731-1617	Tamper Plug (Optional - Not Shown)	1

YARD BOSS 950

REF. NO.	PART NUMBER	DESCRIPTION	QTY.
1	710-0230	Screw, Hex Cap, 1/4-28 x .50	1
2	710-0723	Screw, Hex Cap, 3/8-16 x 1.25	1
3	710-0896	Screw, Hex Wash Hd Tapp. 1/4-14 x .625	5
4	710-0646	Screw, Hex Cap, 5/16-18 x 2.0	1
5	712-0266	Nut, Hex Cent-L Jam, 3/8-16	1
6	712-3004A	Nut, Hex Flange Lock, 5/16-18	2
7	719-0330A	Adapter, Engine Mtg	1
8	731-1584	Belt Cover	1
9	732-0745	Spring, Torsion, .54 x 1.0	1
10	736-0329	Washer, Lock, 1/4	1
11	748-0234	Shoulder Spacer, .50 ID x .27 Lg	1
12	754-0256	V-Belt, 3/8 x 29.0 Lg	1
13	756-0313	Pulley, Flat Idler	1
14	756-0987	Pulley Half, 2.0 Dia	1
15	756-0986	Pulley Half, 2.0 Dia	1
16	781-0611-0662	Bracket, Idler Pivot	1
17	781-0614	Bracket, Idler	1

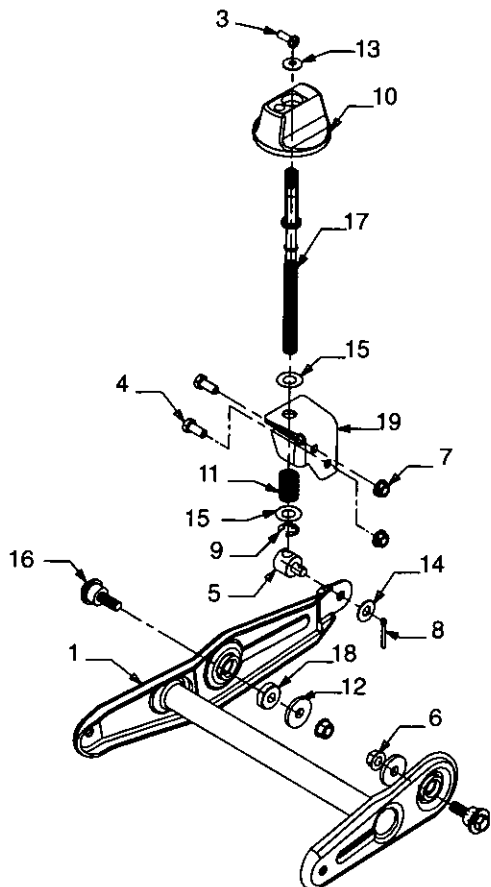
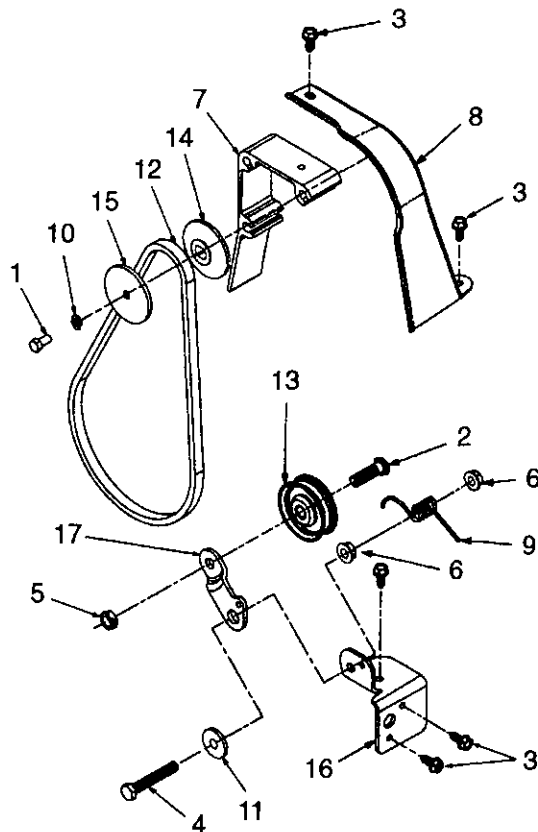

REF. NO.	PART NUMBER	DESCRIPTION	QTY.
1	681-0096-0662	Bracket Ass'y, Wheel Pivot	1
3	710-0924	Screw, Pan Hd Mach, 1/4-20 x .75	1
4	710-3008	Screw, Hex Cap, 5/16-18 x .75 GR5	2
5	711-1041	Ferrule, Adjustment	1
6	712-0431	Nut, Hex Flange Lock, 3/8-16	2
7	712-3004A	Nut, Hex Flange Lock, 5/16-18	2
8	714-0115	Pin, Cotter, 1/8 x 1.0	1
9	716-0104	E-Ring, .50 Dia	1
10	720-0236	Knob	1
11	732-0645	Spring, Compression	1
12	736-0247	Washer, Flat, .406 x 1-1/4	2
13	736-0270	Washer, Bell, .265 x .75 x .062	1
14	736-0300	Washer, Flat, .406 x .875 x .059	1
15	736-0369	Washer, Flat, .508 x 1.0 x .020	2
16	738-0955	Shoulder Bolt, .75 x .43: 3/8-16	2
17	747-0631	Rod, Height Adjustment	1
18	711-0242	Spacer, .380 ID x 1.0 OD x .32 Lg	1
19	781-0605-0662	Bracket, Height Adj	1

YARD BOSS 950

REF. NO.	PART NUMBER	DESCRIPTION	QTY.
1	681-0078	Impeller Ass'y, Complete Includes Ref. Nos. 5 thru 13	1
2	710-1273	Screw, Hex Cap, 3/8-24 x 2.75 GR5	1
3	736-0217	Washer, Lock, 3/8 Heavy Duty 1	1
4	736-0247	Washer, Flat, .406 x 1-1/4 HD1	1
5	681-0052	Impeller Assembly	1
6	711-0833B	Pin, Clevis	3
7	710-1054	Screw, Flat Hd. Cap, 5/16-24 x 1.0	4
8	712-0411	Nut, Hex Insert Lock, 5/16-24	4
9	715-0166	Pin, Spirol, 5/32 x 1.125	3
10	719-0329	Blade, Flail	3
11	736-0119	Washer, Lock, 5/16	4
12	742-0544	Blade, Chipper	2
13	781-0735	Pin Retaining Clip	3

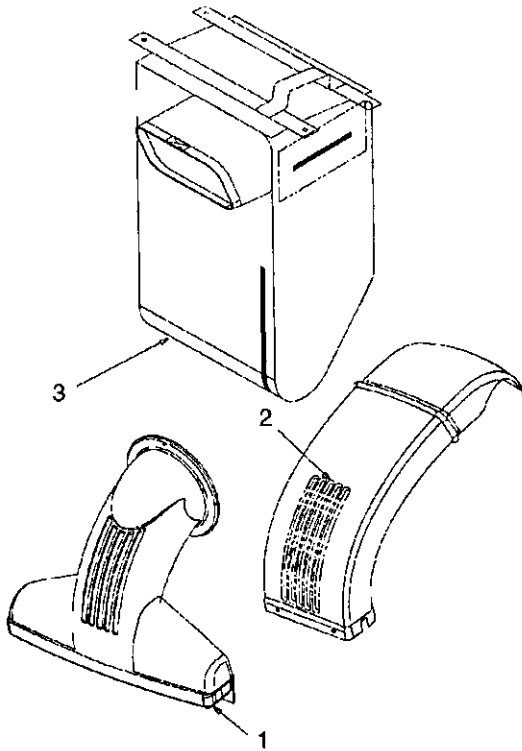
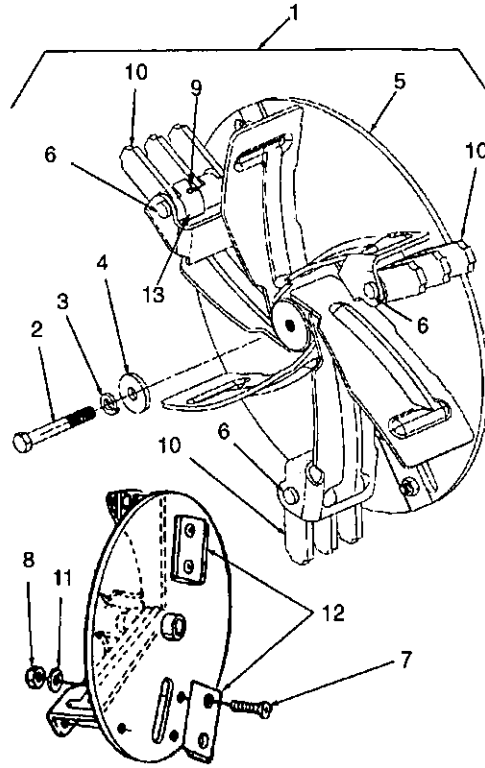

REF. NO.	PART NUMBER	DESCRIPTION	QTY.
1	631-0028	Nozzle Assembly, Vacuum	1
2	731-1573	Chute, Discharge	1
3	764-0472	Bag, Vacuum	1

Labels found on your unit.

PART NUMBER	DESCRIPTION
777S30181	Label—Danger Top of Chipper Chute
777I20350	Label—Squeeze Bail
777I20351	Label—Raise, Lower
777S30183	Label—Warning Top Flail Housing
777S30041	Label—Warning Back Flail Housing
777I20354	Label—6 Speed
777D00299	Label—Hubcaps
777D00092	Label—950 Front of Housing
777D00093	Label—9 HP White

YARD BOSS 950

REF. NO.	PART NUMBER	DESCRIPTION	QTY.
1	618-0168	Differential Ass'y Complete	1
2	710-1206	Screw, Hex Wash Hd Tapp 1/4-20 x 2-5/16	4
3	711-1035	Cross Shaft	1
4	711-1037	Axle Shaft, .75 x 10.95	1
5	711-1038	Axle Shaft, .75 x 9.82	1
6	713-0445	Spocket, 22T	1
7	716-0232	Ring, Retaining	4
8	717-1358	Gear, Differential, 14T	2
9	717-1437	Gear, Differential, 10T	2
10	719-0333	Housing, Differential RH	1
11	719-0334	Housing, Differential LH	1
12	748-0383	Bearing, Flange, .75 ID x 1.0 OD	2
13	737-0300	Grease, Benalene	1 oz
14	721-0328	Sealant, Ultra Grey Loctite 5699	1

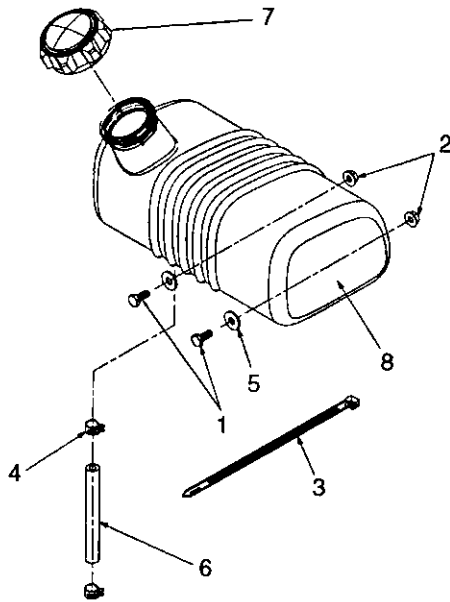
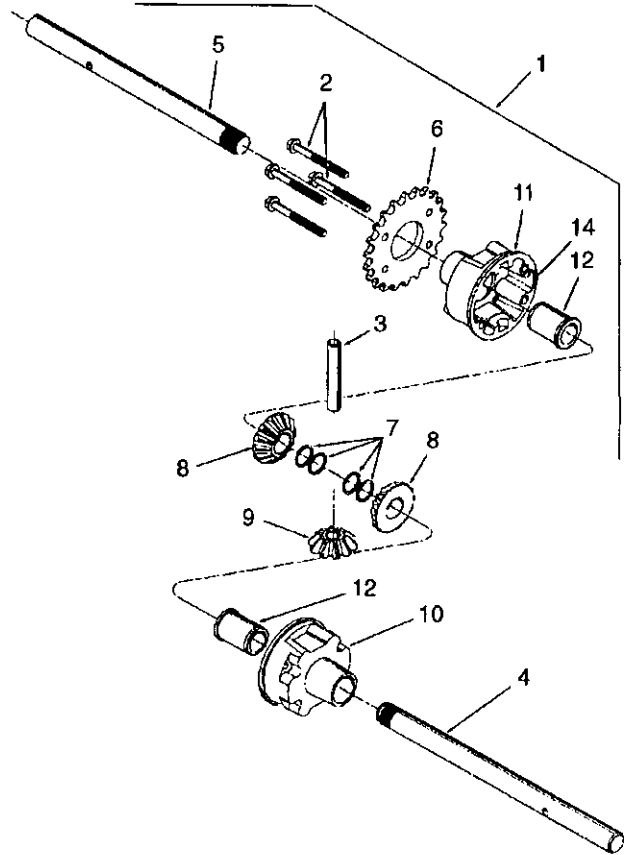

REF. NO.	PART NUMBER	DESCRIPTION	QTY.
1	710-0751	Screw, Hex Cap, 1/4-20 x .62	2
2	712-3027	Nut, Hex Flange Lock, 1/4-20	2
3	726-0209	Cable Tie, 30.66 Lg	1
4	726-0205	Clamp, Hose, 1/2 Inch	2
5	736-0173	Washer, Flat, .28 x .74 x .063	2
6	751-0535	Hose, Fuel Line 9 Inch	9 In.
7	751-0603	Cap, Fuel	1
8	751-0615	Tank, Fuel	1

YARD BOSS 950

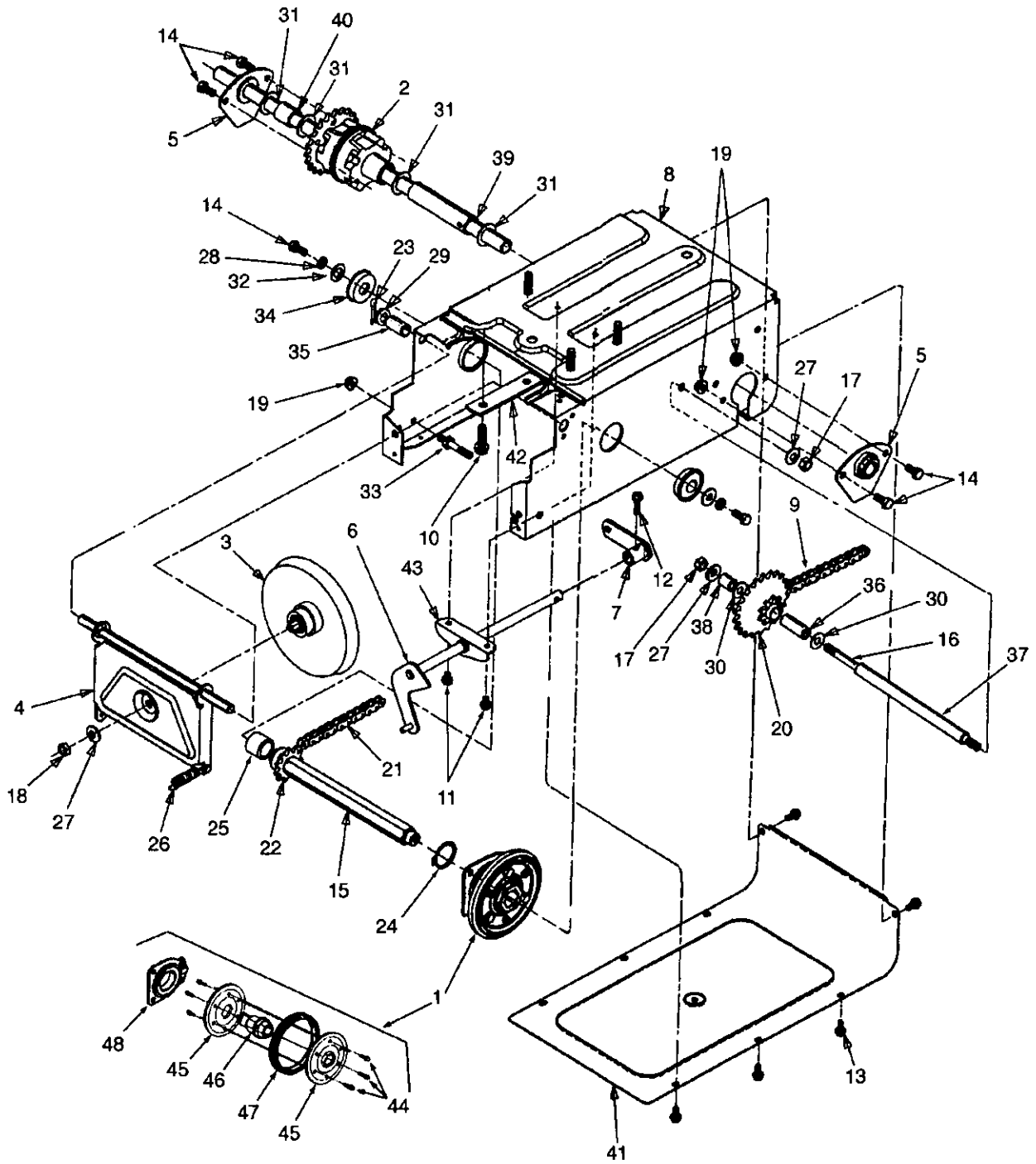

YARD BOSS 950

REF. NO.	PART NUMBER	DESCRIPTION	QTY.	REF. NO.	PART NUMBER	DESCRIPTION	QTY.
1	684-0042B	Friction Wheel Ass'y Complete	1	25	750-0998	Spacer, .675 x 1.0 x 1.53	1
2	618-0168	Differential Ass'y Complete	1	26	732-0209	Spring, Extension	2
3	656-0012A	Friction Disc Assembly	1	27	736-0105	Washer, Bell, .406 x .870 x .063	3
4	681-0055	Bracket Ass'y, Frctn Wheel Supt	1	28	736-0119	Washer, Lock, 5/16	2
5	681-0058	Bracket Ass'y, Axle	2	29	736-0160	Washer, Flat, .536 x .930 x .05	1
6	681-0082	Shaft Ass'y, Shift	1	30	736-0267	Washer, Flat, .385 x .87 x .06	2
7	681-0072	Arm Ass'y, Shift	1	31	736-0287	Washer, Flat, .793 x 1.24 x .06	4
8	681-0081-0498	Frame Assembly	1	32	736-3089	Washer, Flat, .345 x 1.0 x .100	2
9	713-0374	Chain, #420 x 36 Lnks	1	33	738-0908	Bolt, Idler	1
10	710-0502A	Screw, Hex Wash Hd Tapp 3/8-16 x 1.25	4	34	741-0563	Bearing, Ball	2
11	710-0653	Screw, Hex Wash Hd Tapp 1/4-20 x .375	2	35	748-0382	Spacer, .508 x .75 x .94	1
12	710-0788	Screw, Hex Wash Hd Tapp 1/4-20 x 1.0	1	36	750-0351	Sleeve, .380 x .623 x 1.5	1
13	710-0896	Screw, Hex Wash Hd Tapp 1/4-14 x .625	8	37	750-0978	Spacer, .407 x .625 x 7.86	1
14	710-3008	Screw, Hex Cap, 5/16-18 x .75 GR5	6	38	750-0979	Spacer, .407 x .625 x .71	1
15	711-1073	Hex Shaft	1	39	750-0980	Spacer, .782 x 1.0 x 4.11	1
16	711-1028	Jack Shaft	1	40	750-0981	Spacer, .782 x 1.0 x .99	1
17	712-0241	Nut, Hex, 3/8-24	2	41	781-0612A-0498	Cover, Frame Bottom	1
18	712-0711	Nut, Hex Jam, 3/8-24	1	42	781-0638A	Plate, Frame Reinforcement	2
19	712-3004A	Nut, Hex Flange Lock, 5/16-18 GR5	5	43	784-5590-0498	Bracket, Frame Shift	1
20	713-0330	Sprocket Ass'y, 9T & 22T	1	44	710-0599	Screw, Hex Wash Hd Tapp 1/4-20	6
21	713-0284	Chain, #41 x 36 Lnks	1	45	784-5617A	Plate, Friction Wheel	2
22	713-0413	Sprocket, 10T	1	46	718-0301A	Hub, Friction Wheel	1
23	714-0111	Pin, Cotter, 3/32 x 1.0	1	47	735-0243	Wheel, Rubber Friction	1
24	716-0102	Ring, Snap, 1.0 Dia	1	48	618-0063	Bearing Ass'y, Friction Wheel	1

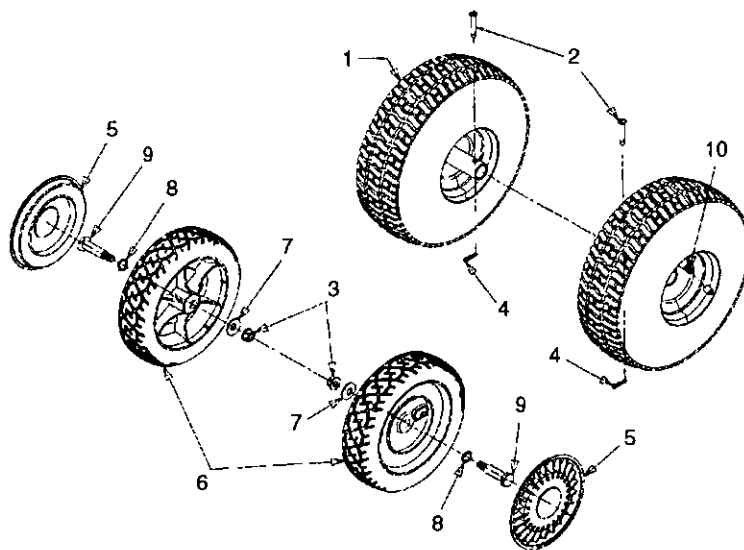

REF. NO.	PART NUMBER	DESCRIPTION	QTY.	REF. NO.	PART NUMBER	DESCRIPTION	QTY.
1	634-0100	Wheel Ass'y Complete	2	6	734-1513B	Wheel Ass'y Complete, 8 x 2.0	2
	634-0101-0662	Rim Assembly	2				
	734-1598	Tire, Pneumatic, 10 x 4	2				
2	711-1017	Pin, Clevis, .25 x 1.53	2	7	736-0105	Washer, Bell, .401 x .870 x .06	2
3	712-0431	Nut, Hex Flange Lock, 3/8-16	2	8	736-0232	Washer, Wave, .53 x .78 x .013	2
4	714-0104	Pin, Internal Cotter	2	9	738-0213	Shoulder Bolt	2
5	731-0981A	Hubcap, Gray	2	10	734-0255	Valve, Tubeless Air	2

Notes





MANUFACTURER'S LIMITED WARRANTY FOR:



The limited warranty set forth below is given by White Outdoor Products Co. with respect to new merchandise purchased and used in the United States, its possessions and territories.

White Outdoor Products Co. warrants this product against defects in material and workmanship for a period of two (2) years commencing on the date of original purchase and will, at its option, repair or replace, free of charge, any part found to be defective in material or workmanship. This limited warranty shall only apply if this product has been operated and maintained in accordance with the Operator's Manual furnished with the product, and has not been subject to misuse, abuse, commercial use, neglect, accident, improper maintenance, alteration, vandalism, theft, fire, water or damage because of other peril or natural disaster. Damage resulting from the installation or use of any accessory or attachment not approved by White Outdoor Products Co. for use with the product(s) covered by this manual will void your warranty as to any resulting damages.

Normal wear parts or components thereof are subject to separate terms as follows: All normal wear part or component failures will be covered on the product for a period of 90 days regardless of cause. After 90 days, but within the two year period, normal wear part failures will be covered ONLY IF caused by defects in material or workmanship of OTHER component parts. Normal wear parts and components include, but are not limited to, belts, blades, blade adapters, grass bags, rider deck wheels, seats, snow thrower skid shoes, shave plates and tires. Batteries are covered by a 90-day limited replacement warranty.

HOW TO OBTAIN SERVICE: Warranty service is available, WITH PROOF OF PURCHASE THROUGH YOUR LOCAL WHITE OUTDOOR DEALER. To locate the dealer in your area, please check for a listing in the Yellow Pages or contact the Customer Dealer Referral Line of White Outdoor Co. by calling 1-330-225-8883 or writing to P.O. Box 361131, Cleveland, Ohio 44136-0019. No product returned directly to the factory will be accepted unless prior written permission has been extended by White Outdoor Co.

This limited warranty does not provide coverage in the following cases:

- a. The engine or component parts thereof. These items carry a separate manufacturer's warranty. Please refer to the applicable manufacturer's warranty on these items.
- b. Log splitter pumps, valves and cylinders have a separate one year warranty.

- c. Routine maintenance items such as lubricants, filters, blade sharpening and tune-ups, or adjustments such as brake adjustments, clutch adjustments or deck adjustments; and normal deterioration of the exterior finish due to use or exposure.
- d. White Outdoor Co. does not extend any warranty for products sold or exported outside of the United States of America, its possessions and territories, except those sold through White Outdoor Co. authorized channels of export distribution.

No implied warranty, including any implied warranty of merchantability or fitness for a particular purpose, applies after the applicable period of express written warranty above as to the parts as identified. No other express warranty or guaranty, whether written or oral, except as mentioned above, given by any person or entity, including a dealer or retailer, with respect to any product shall bind White Outdoor Co. During the period of the Warranty, the exclusive remedy is repair or replacement of the product as set forth above. (Some states do not allow limitations on how long an implied warranty lasts, so the above limitation may not apply to you.)

The provisions as set forth in this Warranty provide the sole and exclusive remedy arising from the sales. White Outdoor Co. shall not be liable for incidental or consequential loss or damages including, without limitation, expenses incurred for substitute or replacement lawn care services, for transportation or for related expenses, or for rental expenses to temporarily replace a warranted product. (Some states do not allow the exclusion or limitation of incidental or consequential damages, so the above exclusion or limitation may not apply to you.)

In no event shall recovery of any kind be greater than the amount of the purchase price of the product sold. Alteration of the safety features of the product shall void this Warranty. You assume the risk and liability for loss, damage, or injury to you and your property and/or to others and their property arising out of the use or misuse or inability to use the product.

This limited warranty shall not extend to anyone other than the original purchaser, original lessee or the person for whom it was purchased as a gift.

How State Law Relates to this Warranty: This limited warranty gives you specific legal rights, and you may also have other rights which vary from state to state.