

GROUP 37

POWER STEERING

CONTENTS

GENERAL INFORMATION	37-2	DRIVE BELT TENSION CHECK AND ADJUSTMENT	37-17
GENERAL SPECIFICATIONS	37-2	FLUID LEVEL CHECK	37-17
SERVICE SPECIFICATIONS	37-3	FLUID REPLACEMENT	37-18
LUBRICANTS	37-3	POWER STEERING SYSTEM AIR BLEEDING	37-19
SEALANTS	37-3	OIL PUMP PRESSURE TEST	37-20
POWER STEERING DIAGNOSIS	37-4	POWER STEERING PRESSURE SWITCH CHECK	37-21
INTRODUCTION TO POWER STEERING DIAGNOSIS	37-4	STEERING WHEEL*	37-22
POWER STEERING DIAGNOSIS TROUBLESHOOTING STRATEGY	37-4	REMOVAL AND INSTALLATION	37-22
SYMPTOM CHART	37-4	STEERING SHAFT*	37-26
SYMPTOM PROCEDURES	37-5	REMOVAL AND INSTALLATION	37-26
SPECIAL TOOLS	37-12	DISASSEMBLY AND REASSEMBLY	37-29
ON-VEHICLE SERVICE	37-14	POWER STEERING GEAR BOX AND LINKAGE*	37-31
STEERING WHEEL FREE PLAY CHECK	37-14	REMOVAL AND INSTALLATION	37-31
STEERING ANGLE CHECK	37-14	INSPECTION	37-35
TIE ROD END BALL JOINT DUST COVER CHECK	37-15	DISASSEMBLY AND REASSEMBLY	37-36
TIE ROD END BALL JOINT BREAKAWAY TORQUE CHECK	37-15	POWER STEERING OIL PUMP ASSEMBLY	37-38
STATIONARY STEERING EFFORT CHECK	37-16	REMOVAL AND INSTALLATION	37-38
STEERING WHEEL RETURN TO CENTER CHECK	37-17	POWER STEERING HOSES	37-40
		REMOVAL AND INSTALLATION	37-40

WARNINGS REGARDING SERVICING OF SUPPLEMENTAL RESTRAINT SYSTEM (SRS) EQUIPPED VEHICLES

⚠ WARNING

- *Improper service or maintenance of any component of the SRS, or any SRS-related component, can lead to personal injury or death to service personnel (from inadvertent firing of the air bag) or to the driver and passenger (from rendering the SRS inoperative).*
- *Service or maintenance of any SRS component or SRS-related component must be performed only at an authorized MITSUBISHI dealer.*
- *MITSUBISHI dealer personnel must thoroughly review this manual, and especially its GROUP 52B - Supplemental Restraint System (SRS) before beginning any service or maintenance of any component of the SRS or any SRS-related component.*

NOTE

The SRS includes the following components: SRS air bag control unit, SRS warning light, front impact sensors, driver's and passenger's (front) air bag modules, knee air bag module, side-airbag module, curtain air bag module, side impact sensors, seat belt pre-tensioners, clock spring, and interconnecting wiring. Other SRS-related components (that may have to be removed/installed in connection with SRS service or maintenance) are indicated in the table of contents by an asterisk (*).

GENERAL INFORMATION

M1372000101192

- The steering wheel has three spokes. All vehicles are equipped with SRS (Supplemental Restraint System).
- The steering column has a shock absorbing mechanism and a tilt steering mechanism.
- The steering system uses a vane oil pump with a fluid flow control system, so that steering effort varies with engine speed.

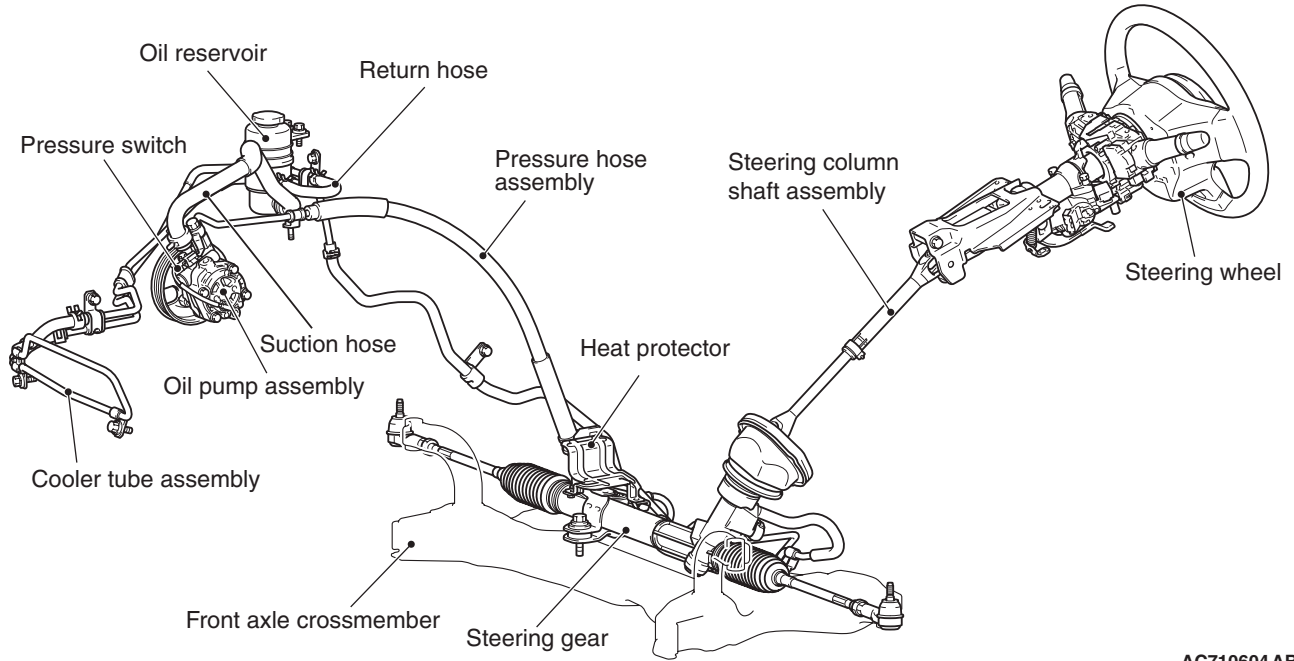

AC710604 AB

GENERAL SPECIFICATIONS

M1372000200431

Item		Specification
Power steering gear box	Type	Rack and pinion
	Stroke ratio (Rack stroke/Steering wheel maximum turning radius) mm/rev (in/rev)	65.97 (2.59)
Oil pump	Type	Vane type
	Displacement cm ³ /rev (cu in/rev)	9.0 (0.55)
	Relief set pressure MPa (psi)	8.55 (1.197)

SERVICE SPECIFICATIONS

M1372000301390

Item		Standard value	Limit
Steering wheel free play mm (inch)	With engine running	–	30 (1.2)
	With engine stopped	16.5 (0.6) or less	–
Steering angle	Inside wheel	33° 10' ± 1° 30'	–
	Outside wheel (reference value)	28° 10'	–
Toe-in mm (in)		0 ± 2 (0 ± 0.07)	–
Tie rod end ball joint breakaway torque N· m (in-lb)		2.9 (26) or less	–
Engine idle speed r/min		700 ± 50	–
Stationary steering effort N (lb) [Fluctuation allowance N (lb)]		32 (7.2) or less [5.9 (1.33) or less]	–
Oil pump pressure MPa (psi)	Oil pump relief pressure	8.1 – 8.8 (1,174 – 1,276)	–
	Pressure under no-load conditions	1.0 (144)	–
	Steering gear retention hydraulic pressure	8.1 – 8.8 (1,174 – 1,276)	–
Steering gear total pinion torque N· m (in-lb) [Change in torque N· m (in-lb)]		0.6 – 2.0 (5.2 – 17.6) [0.4 (3.5) or less]	–
Band crimped width mm (in)		2.4 – 2.8 (0.09 – 0.11)	–

LUBRICANTS

M1372000400822

Item		Specified lubricant	Quantity dm ³ (qt)
Power steering fluid		Genuine Mitsubishi Power Steering Fluid	1.0 (1.06)
Steering gear	Bearing	Genuine Mitsubishi Power Steering Fluid	As required
	O-ring and seal ring		
	Oil seal		
	Special tool (MB991213)		
	Pinion and valve assembly seal ring part		
	Bellows	Silicon grease	As required
Oil pump	Friction surface of rotor vane, cam ring and pump cover	Genuine Mitsubishi Power Steering Fluid	As required
	O-ring		

SEALANTS

M1372000500852

Item		Specified sealant
Steering gear	Bellows	3M™ AAD Part No.8663 or equivalent

POWER STEERING DIAGNOSIS

INTRODUCTION TO POWER STEERING DIAGNOSIS

M1372008500254

Hydraulic power steering is used for all vehicles. Faults in the power steering can include excessive play of the steering wheel, difficult steering wheel operation, noise, vibration, and oil leaks, etc. Possible causes of these faults can include defects in the gear box, oil pump or steering linkage.

POWER STEERING DIAGNOSIS TROUBLESHOOTING STRATEGY

M1372007300291

Use these steps to plan your diagnostic strategy. If you follow them carefully, you will be sure that you have exhausted most of the possible ways to find a power steering fault.

1. Gather information from the customer.

2. Verify that the condition described by the customer exists.

3. Find the malfunction by following the Symptom Chart.

4. Verify malfunction is eliminated.

SYMPTOM CHART

M1372007600366

Symptom	Inspection procedure	Reference page
Excessive play of steering wheel	1	P.37-5
Difficult steering wheel operation (insufficient power assist)	2	P.37-6
Rattling noise	3	P.37-7
Shrill noise	4	P.37-8
Squealing noise	5	P.37-8
Hissing noise	6	P.37-8
Droning noise	7	P.37-9
Squeaking noise	8	P.37-9
Vibration	9	P.37-10
Oil leakage from hose connection	10	P.37-10
Oil leakage from hose assembly	11	P.37-11
Oil leakage from oil reservoir	12	P.37-11
Oil leakage from oil pump	13	P.37-11
Oil leakage from steering gear	14	P.37-12

SYMPTOM PROCEDURES

INSPECTION PROCEDURE 1: Excessive Play of Steering Wheel

DIAGNOSIS

STEP 1. Check for looseness at the steering shaft coupling section and at the steering wheel linkage.

Q: Is there any looseness?

YES : Repair or replace the part. Then go to Step 3.

NO : Go to Step 2.

STEP 2. Check the steering wheel free play.

(1) With the engine running (hydraulic operation), set the front wheels straight ahead.

(2) Measure the play on the steering wheel circumference before the wheels start to move when slightly moving the steering wheel in both directions.

Limit: 30 mm (1.2 inch)

(3) If the free play exceeds the limit value, set the steering wheel straight ahead with the engine stopped. Load approximately 5 N (1.1 pound) towards the steering circumference and check the play.

Standard value (steering wheel play with engine stopped): 16.5 mm (0.6 inch) or less

Q: Does the play exceed the standard value?

YES : Remove the steering gear box (Refer to [P.37-31](#)) and check the total pinion torque (Refer to [P.37-31](#)). Then go to Step 3.

NO : Go to Step 3.

STEP 3. Check the steering wheel play.

Verify that the steering wheel play is not excessive.

Q: Is the steering wheel play excessive?

YES : Repeat from Step 1.

NO : The procedure is complete.

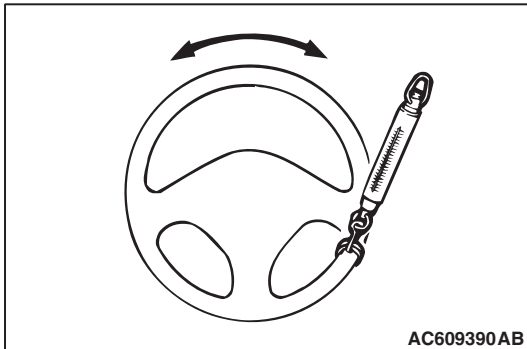

INSPECTION PROCEDURE 2: Difficult Steering Wheel Operation (Insufficient Power Assist)

DIAGNOSIS

STEP 1. Check the power steering oil pump drive belt tension.

Refer to GROUP 00, Maintenance Service –Drive Belts [P.00-66](#).

Q: Is the power steering oil pump drive belt tension within the standard value?

YES : Go to Step 2.

NO : Adjust the tension (Refer to GROUP 00, Maintenance Service –Drive Belts [P.00-66](#)). Then go to Step 10.

STEP 2. Check the drive belt for damage.**Q: Is the drive belt damaged?**

YES : Replace the drive belt. Then go to Step 10.

NO : Go to Step 3.

STEP 3. Check the fluid level.

- (1) Park the vehicle on a flat, level surface, and then start the engine.
- (2) Turn the steering wheel several times to raise the temperature of the fluid to approximately 50 –60° C (122 – 140° F).
- (3) With the engine running, turn the wheel all the way to the left and right several times.
- (4) Check the fluid in the oil reservoir for foaming or milkiness. Check the difference of the fluid level when the engine is stopped, and while it is running. If the change of the fluid level is 5 mm (0.2 inch) or more, bleed the air from the system (Refer to [P.37-19](#)).

Q: Is the fluid foamy?

YES : Go to Step 4.

NO : Go to Step 10.

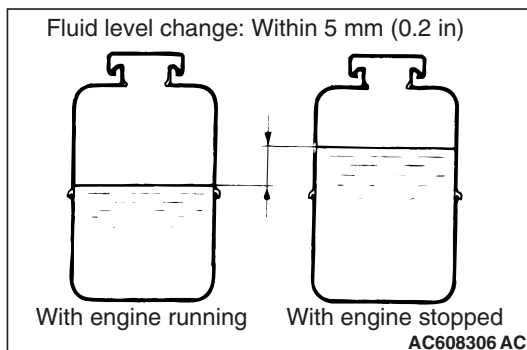
**STEP 4. Check for entry of air.****Q: Has air entered?**

YES : Bleed the air (Refer to [P.37-19](#)). Then go to Step 10 .

NO : Go to Step 5.

STEP 5. Check each hose for crushing or twisting.**Q: Is any hose crushed or twisted?**

YES : Repair or replace the hose. Then go to Step 10.

NO : Go to Step 6.

STEP 6. Check for oil leaks.

Q: Are there oil leaks?

YES : Repair it. Then go to Step 10.

NO : Go to Step 7.

STEP 7. Check the wheel alignment (camber and caster).

Refer to GROUP 33, On-vehicle Service –Front Wheel Alignment Check and Adjustment [P.33-7](#).

Q: Is the alignment incorrect?

YES : Repair it. Then go to Step 10.

NO : Go to Step 8.

STEP 8. Check the gear box rack piston seal for damage.

Q: Is there damage?

YES : Replace it. Then go to Step 10.

NO : Go to Step 9.

STEP 9. Check for excessive tie rod end ball joint breakaway torque.

Refer to [P.37-15](#).

Q: Is there fault?

YES : Replace the part. Then go to Step 10.

NO : Go to Step 10.

STEP 10. Check the steering wheel operation.

Verify that the steering wheel operation is not difficult.

Q: Is the steering wheel operation difficult?

YES : Repeat from Step 1.

NO : The procedure is complete.

INSPECTION PROCEDURE 3: Rattling Noise

DIAGNOSIS

STEP 1. Check for proper oil pump and steering gear installation.

Q: Is the oil pump and the steering gear installation correct?

YES : Go to Step 2.

NO : Repair it. Then go to Step 4.

STEP 2. Check for interference of other parts with the steering column and the power steering hoses.

Q: Is there interference?

YES : Correct the interference. Then go to Step 4.

NO : Go to Step 3.

STEP 3. Check for noise from inside the oil pump or the steering gear.

Q: Is there noise?

YES : Replace the part. Then go to Step 4.

NO : Go to Step 4.

STEP 4. Check for rattling noise.

Confirm that no noise is generated.

Q: Is there noise?

YES : Repeat from Step 1.

NO : The procedure is complete.

INSPECTION PROCEDURE 4: Shrill Noise**DIAGNOSIS****STEP 1. Check for entry of air.****Q: Is the power steering fluid foamy?****YES :** Bleed the air (Refer to [P.37-19](#)). Then go to Step 3.**NO :** Go to Step 2.**STEP 2. Check for seizure in the oil pump.****Q: Is there seizure?****YES :** Replace the part. Then go to Step 3.**NO :** Go to Step 3.**STEP 3. Retest the system.**

Confirm that no noise is generated.

Q: Is there noise?**YES :** Repeat from Step 1.**NO :** The procedure is complete.**INSPECTION PROCEDURE 5: Squealing Noise****DIAGNOSIS****STEP 1. Check the drive belt tension.**Refer to GROUP 00, Maintenance Service –Drive Belts [P.00-66](#).**Q: Is the drive belt tension incorrect?****YES :** Adjust the belt tension (Refer to GROUP 00, Maintenance Service –Drive Belts [P.00-66](#)). Then go to Step 3.**NO :** Go to Step 2.**STEP 2. Check for seizure in the oil pump.****Q: Is there seizure?****YES :** Replace the part. Then go to Step 3.**NO :** Go to Step 3.**STEP 3. Retest the system.**

Confirm that no noise is generated.

Q: Is there noise?**YES :** Repeat from Step 1.**NO :** The procedure is complete.**INSPECTION PROCEDURE 6: Hissing Noise****DIAGNOSIS****STEP 1. Check for entry of air.****Q: Is the power steering fluid foamy?****YES :** Bleed the air (Refer to [P.37-19](#)). Then go to Step 4.**NO :** Go to Step 2.**STEP 2. Check each hose for crushing or twisting.****Q: Is any hose crushed or twisted?****YES :** Repair or replace the hose. Then go to Step 4.**NO :** Go to Step 3.**STEP 3. Check the steering gear for damage.****Q: Is there damage?****YES :** Repair or replace the part. Then go to Step 4.**NO :** Go to Step 4.**STEP 4. Retest the system.**

Confirm that no noise is generated.

Q: Is there noise?**YES :** Repeat from Step 1.**NO :** The procedure is complete.

INSPECTION PROCEDURE 7: Droning Noise

DIAGNOSIS

STEP 1. Check the oil pump or oil pump bracket installation.

Q: Is the oil pump or the oil pump bracket installation correct?
YES : Go to Step 2.
NO : Repair it. Then go to Step 3.

STEP 2. Check the oil pump for damage.

NOTE: If a slight "beat noise" is produced by the oil pump when the steering wheel is turned fully and held in that position, this is not a malfunction.

Q: Is there damage?
YES : Replace the oil pump. Then go to Step 3.
NO : Go to Step 3.

STEP 3. Retest the system.
 Confirm that no noise is generated.

Q: Is there noise?
YES : Repeat from Step 1.
NO : The procedure is complete.

INSPECTION PROCEDURE 8: Squeaking Noise

DIAGNOSIS

STEP 1. Check for interference of the wheel and the vehicle body.

If interfering, adjust the steering angle.

(1) Place the front wheel on a turning radius gauge and measure the steering angle.

Standard value:

Item	Specification
Inside wheel	33° 10' ± 1° 30'
Outside wheel (reference value)	28° 10'

(2) If the steering angle is not within the standard value, adjust the toe-in.

Standard value: 0 ± 2 mm (0 ± 0.07 inch)

(3) Adjust the toe-in by undoing the clip and jam nut, and turning the left and right tie rod turnbuckles by the same amount (in opposite directions).

NOTE: The toe will move out as the left turnbuckle is turned toward the front of the vehicle and the right turnbuckle is turned toward the rear of the vehicle.

Q: Is the steering angle normal?

YES : Go to Step 2.
NO : Adjust the steering angle. Then go to Step 3.

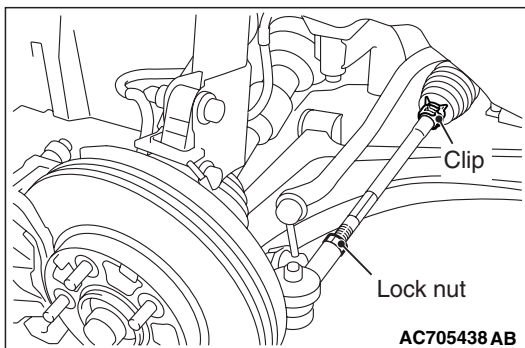
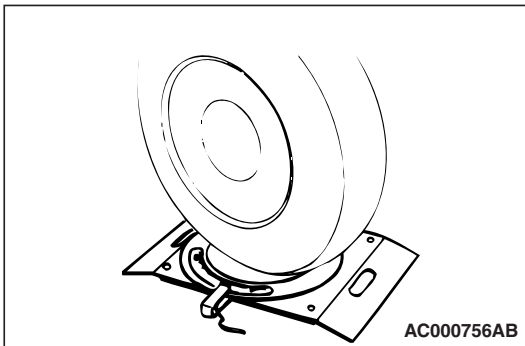

STEP 2. Check the steering gear for damage.**Q: Is there damage?****YES** : Repair or replace the part. Then go to Step 3.**NO** : Go to Step 3.**STEP 3. Retest the system.**

Confirm that no noise is generated.

Q: Is there noise?**YES** : Repeat from Step 1.**NO** : The procedure is complete.**INSPECTION PROCEDURE 9: Vibration**

NOTE: A slight vibration may be felt when the stationary steering effort is made due to the condition of the road surface. To check whether the vibration actually exists or not, test-drive the vehicle on a dry concrete or asphalt surface. A very slight amount of vibration is not a malfunction.

DIAGNOSIS**STEP 1. Check for entry of air.****Q: Is the power steering fluid foamy?****YES** : Bleed the air (Refer to [P.37-19](#)). Then go to Step 3.**NO** : Go to Step 2.**STEP 2. Check the steering gear for damage.****Q: Is there damage?****YES** : Repair or replace the part. Then go to Step 3.**NO** : Go to Step 3.**STEP 3. Retest the system.**

Confirm that no vibration is generated.

Q: Is there vibration?**YES** : Repeat from Step 1.**NO** : The procedure is complete.**INSPECTION PROCEDURE 10: Oil Leakage from Hose Connection****DIAGNOSIS****STEP 1. Check for loosening of the return tube flare nut.****Q: Is the flare nut loose?****YES** : Tighten it to 15 ± 3 N·m (11 ± 2 ft-lb). Then go to Step 3.**NO** : Go to Step 2.**STEP 2. Check the hose connection and the clamp installation.****Q: Are they correct?****YES** : Go to Step 3.**NO** : Repair or replace the part. Then go to Step 3.**STEP 3. Retest the system.**

Check that no oil is leaking.

Q: Is there oil leakage?**YES** : Repeat from Step 1.**NO** : The procedure is complete.

INSPECTION PROCEDURE 11: Oil Leakage from Hose Assembly

DIAGNOSIS

STEP 1. Check the hose for damage or clogging.

Q: Is the hose damaged or clogged?

YES : Repair or replace it. Then go to Step 2.

NO : Go to Step 2.

STEP 2. Retest the system.

Check that no oil is leaking.

Q: Is there oil leakage?

YES : Repeat from Step 1.

NO : The procedure is complete.

INSPECTION PROCEDURE 12: Oil Leakage from Oil Reservoir

DIAGNOSIS

STEP 1. Check the oil reservoir for damage.

Q: Is there damage?

YES : Repair or replace it. Then go to Step 3.

NO : Go to Step 2.

STEP 2. Check for overflowing.

Q: Is there oil overflowing from the reservoir?

YES : Adjust fluid level. Then go to Step 3.

NO : Go to Step 3.

STEP 3. Retest the system.

Q: Is there oil leakage?

YES : Repeat from to Step 1.

NO : The procedure is complete.

INSPECTION PROCEDURE 13: Oil Leakage from Oil Pump

DIAGNOSIS

STEP 1. Check the oil pump body for damage.

Q: Is there damage?

YES : Replace the part. Then go to Step 3.

NO : Go to Step 2.

STEP 2. Check the O-ring or oil seal for damage.

Q: Is there damage?

YES : Replace the part. Then go to Step 3.

NO : Go to Step 3.

STEP 3. Retest the system.

Check that no oil is leaking.

Q: Is there oil leakage?

YES : Repeat from Step 1.

NO : The procedure is complete.

INSPECTION PROCEDURE 14: Oil Leakage from Steering Gear

DIAGNOSIS

STEP 1. Check the steering gear housing for damage.

Q: Is there damage?

YES : Replace the part. Then go to Step 3.

NO : Go to Step 2.

STEP 2. Check the oil-ring or oil seal for damage.

Q: Is there damage?

YES : Replace the part. Then go to Step 3.

NO : Go to Step 3.

STEP 3. Retest the system.

Check that no oil is leaking.

Q: Is there oil leakage?

YES : Repeat from Step 1.

NO : The procedure is complete.

SPECIAL TOOLS

M1372000601175

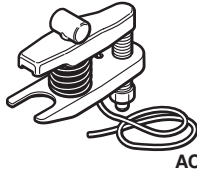
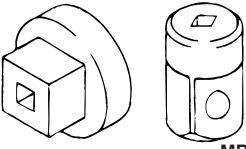
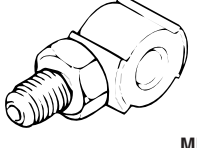
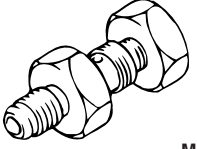
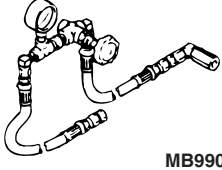
Tool	Tool number and name	Supersession	Application
 AC106827	MB991897 or MB992011 Ball joint remover	MB991113-01, MB990635-01 or General service tool	Knuckle and tie rod end ball joint disconnection <i>NOTE: Steering linkage puller (MB990635 or MB991113) is also available to disconnect knuckle and tie rod end ball joint.</i>
 MB990326	MB990326 Preload socket	General service tool	Tie rod end ball joint breakaway torque check
 MB991548	MB991548 Power steering oil pressure gauge adapter (Pump side)	MB991548-01	Oil pump pressure test
 MB991549	MB991549 Power steering oil pressure gauge adapter (Hose side)	MB991549-01	
 MB990662	MB990662 Power steering oil pressure gauge	MB990662-01	

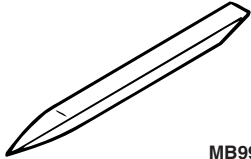
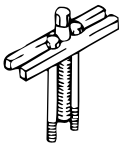
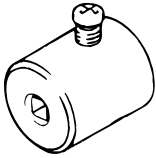
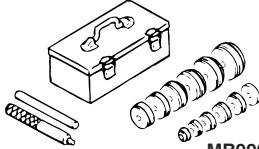
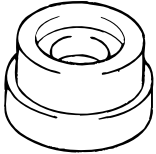
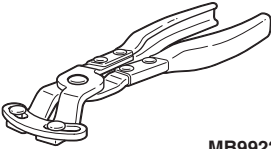
Tool	Tool number and name	Supersession	Application
 <p>MB990784</p>	<p>MB990784 Ornament remover</p>	<p>General service tool</p>	<p>Cover removal</p>
 <p>MB990803</p>	<p>MB990803 Steering wheel puller</p>	<p>General service tool</p>	<p>Steering wheel removal</p>
 <p>MB991006</p>	<p>MB990228 or MB991006 Preload socket</p>	<p>MB990228-01</p>	<p>Steering gear total pinion torque check</p>
 <p>MB990925</p>	<p>MB990925 Bearing and oil seal installer set</p>	<p>MB990925-01 or general service tool</p>	<ul style="list-style-type: none"> • Oil seal and bearing installation • MB990927, MB990938, MB990939 (For details, refer to GROUP 26 – Special Tools P.26-6).
 <p>MB991203</p>	<p>MB991203 Oil seal and bearing installer</p>	<p>Tool not available</p>	<p>Oil seal and bearing installation</p>
 <p>MB992209</p>	<p>MB992209 Bellows band crimping tool</p>	<p>MB992209</p>	<p>Bellows band installation</p>

ON-VEHICLE SERVICE

STEERING WHEEL FREE PLAY CHECK

M1372001000850

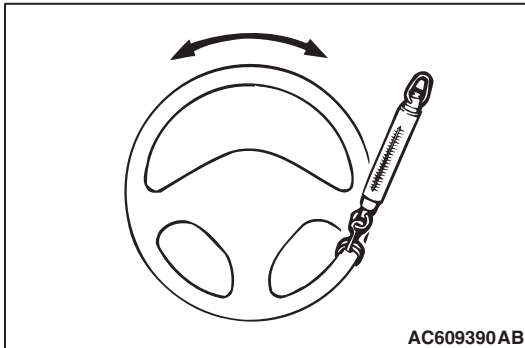

1. With the engine running (hydraulic pressure applied), position the front wheel in the straight ahead position.
2. Measure the side to side steering wheel play until the front wheels actually start moving while turning the steering wheel slightly in the left and right directions.

Limit: 30 mm (1.2 inch)

3. If the steering wheel play exceeds the limit value, check the steering shaft joint or steering linkage for looseness, and replace or repair the faulty components if necessary.
4. If the steering wheel play still exceeds the limit value after Step 3 is performed, position the steering wheel in the straight ahead position, and then apply the force (approximately 5 N) in the circumferential direction.

Standard value (steering wheel play with the engine stopped): 16.5 mm (0.6 inch) or less

5. If the steering wheel play is outside the standard value after Step 4 is performed, remove the steering gear and linkage, and check and adjust the pinion total rotation torque. (Refer to [P.37-31](#)).

STEERING ANGLE CHECK

M1372001101225

⚠ CAUTION

After adjusting the steering angle, perform calibration to make the ASC-ECU learn the neutral position of the steering wheel sensor. (Refer to **GROUP 35C –On-vehicle Service, Steering Wheel Sensor Calibration P.35C-267.**)

1. Check that the wheel alignment is normal. (Refer to **GROUP 33 –On-vehicle Service, Wheel Alignment Check and Adjustment** (Refer to [P.33-7.](#)))
2. Place the front wheel onto the turning radius gauge, and measure the steering angle.

Standard value:

Item	Specifications
Inside wheel	33° 10' ± 1° 30'
Outside wheel (reference value)	28° 10'

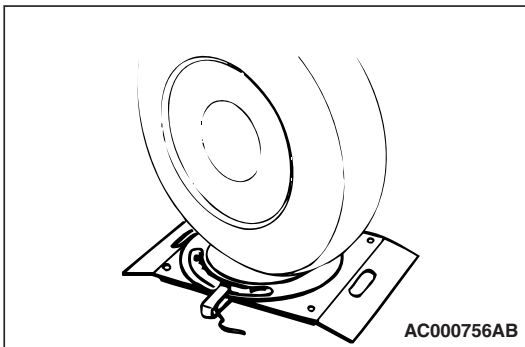

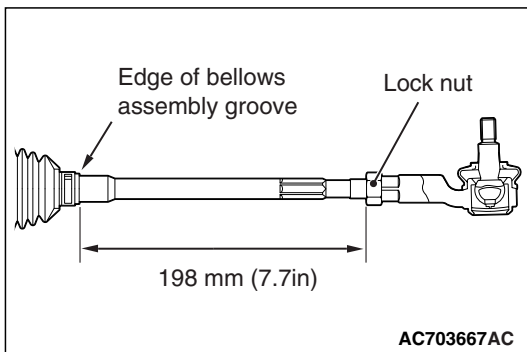

3. If the measured value is not within the standard value, adjust the tie-rod ends (right and left), and repeat Steps 1 and 2.
4. If the measured value is not within the standard value after performing Step 3, replace the steering gear and linkage assembly. (Refer to P.37-31.)

TIE ROD END BALL JOINT DUST COVER CHECK

M1372008600701

1. Using your fingers, press the dust cover to check for cracks or damage.
2. If there are any cracks in the dust cover or it is damaged, replace the tie-rod end (Refer to P.37-36).

NOTE: If the dust cover has a crack or damage, the ball joint could be damaged.

TIE ROD END BALL JOINT BREAKAWAY TORQUE CHECK

M1372011600217

Required Special Tools:

- MB990326: Preload Socket
- MB991897 or MB992011: Ball Joint Remover

⚠ CAUTION

- **Loosen the self-locking nut (tie-rod end connection) from the ball joint, but do not remove here. Use the special tool.**
- **To prevent the special tool from dropping off, suspend it with a rope.**

1. Install special tool MB991897 or MB992011 as shown in the figure.

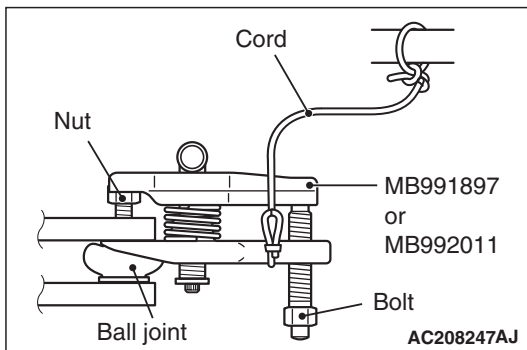

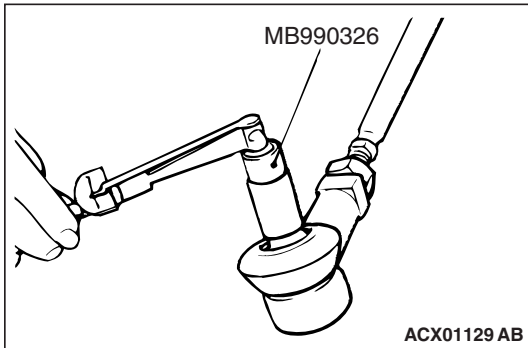
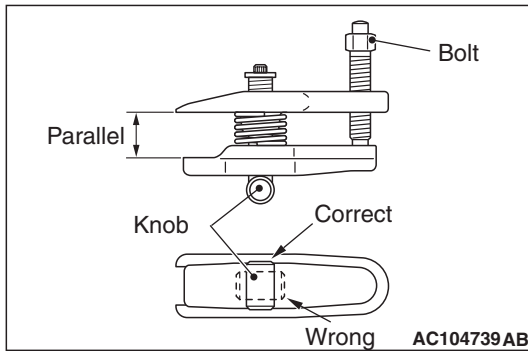

- Turn the bolt and knob to make the special tool jaws parallel, then hand-tighten the bolt. After tightening, check that the jaws are still parallel.
NOTE: To adjust the special tool jaws to be parallel, set the orientation of the knob as shown in the figure.
- Unscrew the bolt to disconnect the ball joint.

- Move the ball joint stud several times and install the nut on the stud. Using the special tool MB990326, measure the ball joint breakaway torque.

Standard value: 2.9 N·m (26 in-lb) or less

- If the breakaway torque exceeds the standard value, replace the tie rod end.
- If the breakaway torque is under the standard value, check the ball joint for end play or ratcheting. If no end play or ratcheting, the ball joint can be re-used.

⚠ CAUTION

Always use a new ball joint nut as it is a self-locking nut.

- Install the tie rod end to the knuckle, then tighten a new self-locking nut to the specified torque.

Tightening torque: 40 ± 8 N·m (30 ± 5 ft-lb)

STATIONARY STEERING EFFORT CHECK

M1372001700945

- Park the vehicle on a level paved road, position the steering wheel in the straight ahead position.
- Start the engine, and maintain the engine speed at 1000 ± 100 r/min.
- Position the spring scale on the circumference of the steering wheel, and measure the steering force at the time when the steering wheel is turned to right or left side (within the range of one and a half turns) from the center position.

Standard value:

Steering force: 32 N (7.2 lb) or less

Fluctuation band: 5.9 N (1.33 lb) or less

- If not within the standard value, check and adjust the suspected components.

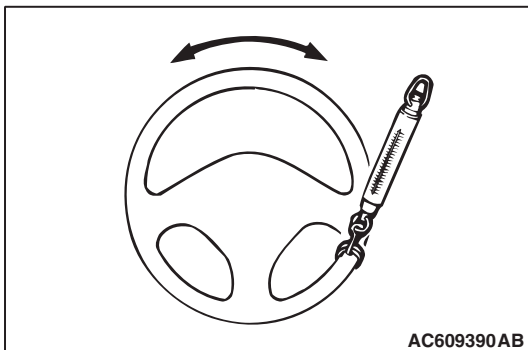

STEERING WHEEL RETURN TO CENTER CHECK

M1372001800715

Conduct a road test:

1. Make both gradual and sudden turns and check the steering wheel return.
2. At a vehicle speed of approximately 35 km/h (22 mph), turn the steering wheel 90 degrees, hold a few seconds, then release. If the steering wheel then returns 70 degrees or more, the return can be judged satisfactory.

NOTE: There will be a momentary feeling or "heaviness" when the wheel is turned quickly, but this is not abnormal (Oil pump discharge amount is especially apt to be insufficient during idling).

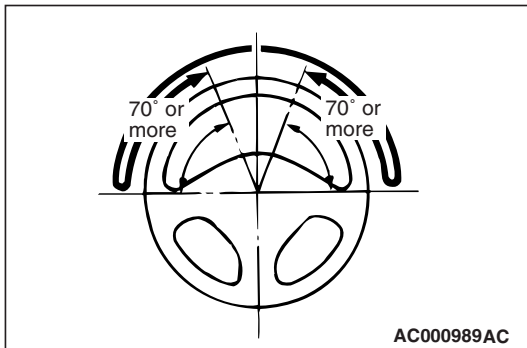

AC000989AC

DRIVE BELT TENSION CHECK AND ADJUSTMENT

M1372001900864

Refer to GROUP 11A –Engine Adjustment, and Drive Belt Tension Check and Adjustment [P.11A-8.](#))

FLUID LEVEL CHECK

M1372002000648

1. Park the vehicle on a flat, level surface.
2. Start the engine, and then turn the steering wheel several times to raise the temperature of the fluid to approximately 50 –60° C (122 –140° F).
3. With the engine running, turn the wheel all the way to the left and right several times.
4. Check the fluid in the oil reservoir for foaming or milkiness. Check the difference of the fluid level when the engine is stopped, and while it is running. If the change of the fluid level is 5 mm (0.2 inch) or more, air bleeding should be done (Refer to [P.37-19](#)).

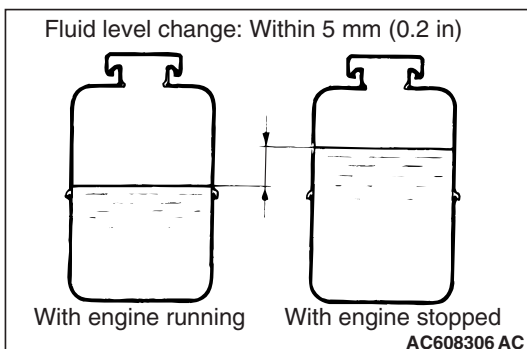

AC608306 AC

FLUID REPLACEMENT

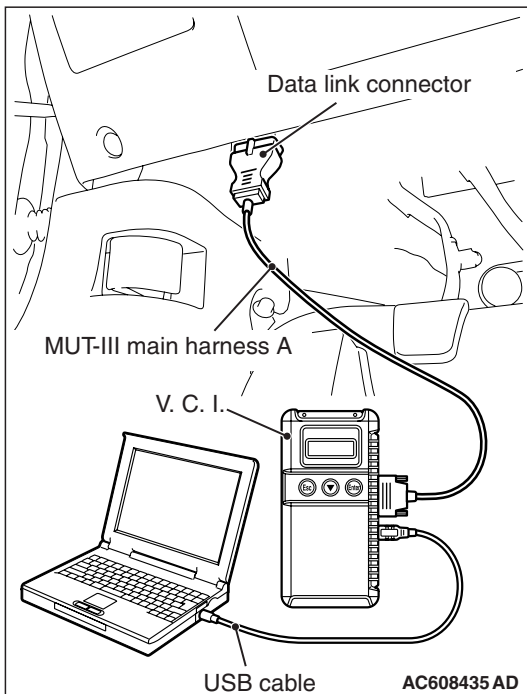
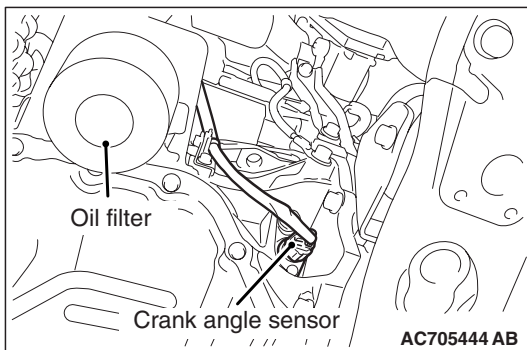
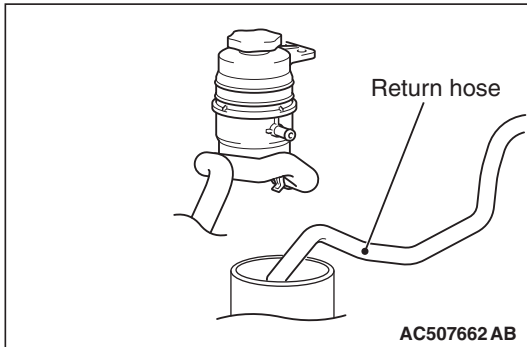

1. Raise and support the front wheels.
2. Disconnect the return hose connection, and then connect a vinyl hose to the return hose, and drain the fluid into a container.
3. Disconnect the crank angle sensor connector.
4. While operating the starter motor intermittently, turn the steering wheel all the way to the left and right several times to drain all of the fluid.
5. Connect the return hose securely, and then secure with the clip.
6. Fill the oil reservoir with GENUINE MITSUBISHI POWER STEERING FLUID to the lower position of the filler, and then bleed the air (Refer to [P.37-19](#)).
7. Install the crankshaft position sensor.
8. Use the scan tool MB991958, check if the DTC is set. If it is set, erase it.

POWER STEERING SYSTEM AIR BLEEDING

M1372002200909

Perform air bleeding procedure as necessary after replacing the steering gear or the steering fluid lines.

1. Raise and support the front wheels.
2. Disconnect the crank angle sensor connector.

⚠ CAUTION

Perform air bleeding only while cranking the engine. If air bleeding is performed while the engine is running, air could enter the fluid. During air bleeding, refill the steering fluid supply so that the level never falls below the lower mark on the dipstick.

3. Turn the steering wheel all the way to the left and right five or six times while using the starter motor to crank the engine intermittently several times (for 15 to 20 seconds).
4. Connect the crank angle sensor connector.
5. Start the engine (idling).
6. Turn the steering wheel to the left and right until there are no air bubbles in the oil reservoir.
7. Confirm that the fluid is not milky, and that the level is between the high and low dipstick marks.
8. Confirm that there is very little change in the fluid level when the steering wheel is turned left and right.

⚠ CAUTION

If the fluid level rises suddenly after the engine is stopped, the air has not been completely bled. If air bleeding is not complete, there will be abnormal noises from the pump and the flow-control valve, and this condition could cause reduce the life of the power steering components.

9. Confirm that the change in the fluid level is no more than 5 mm (0.2 inch) when the engine is stopped and when it is running.

10. If the change of the fluid level is 5 mm (0.2 inch) or more, the air has not been completely bled from the system. The air bleeding procedure must be repeated.

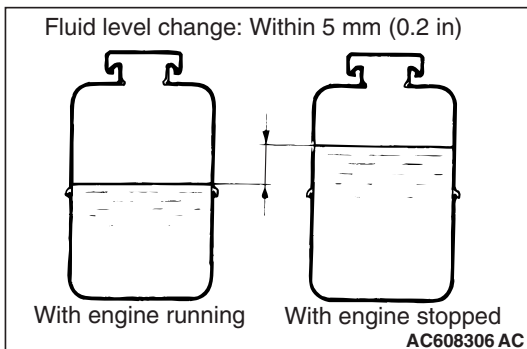
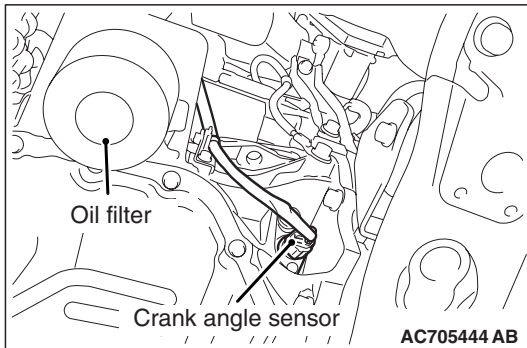

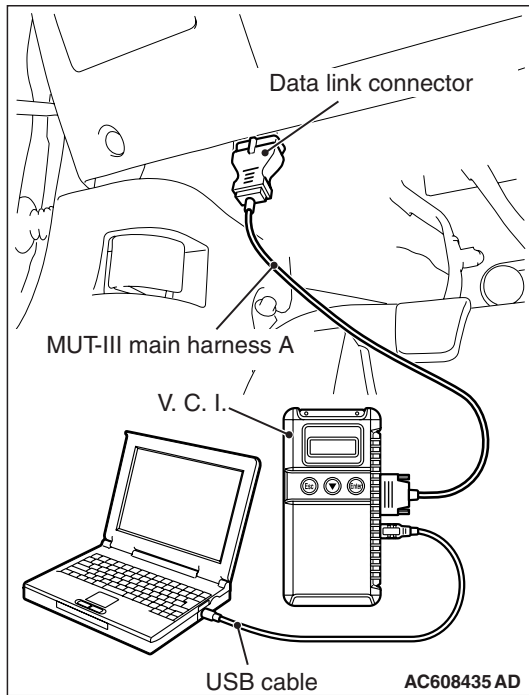

- Use the scan tool MB991958, check if the DTC is set. If it is set, erase it.

OIL PUMP PRESSURE TEST

M1372002300757

Required Special Tools:

- MB990662: Power Steering Oil Pressure Gauge
- MB991548: Power Steering Oil Pressure Gauge Adapter (Pump Side)
- MB991549: Power Steering Oil Pressure Gauge Adapter (Hose Side)

- Disconnect the pressure hose from the oil pump, and then connect the special tools MB991548, MB990662 and MB991549.
- Bleed air, then turn the steering wheel several times while the vehicle is not moving so that the temperature of the fluid rises to approximately 50 –60° C (122 –140° F).
- Start the engine and idle it at 1000 ± 100 r/min.

CAUTION

The pressure gauge shut-off valve must not remain closed for more than 10 seconds.

- Fully close the shut-off valve of the pressure gauge and measure the oil pump relief pressure to confirm that it is within the standard value range. Open it again immediately after checking the pressure.

Standard value: 8.1 –8.8 MPa (1,174 –1,276 psi)

- If it is not within the standard value, replace the oil pump.
- Check whether or not the hydraulic pressure is the standard value when no-load conditions are created by fully opening the shut-off valve of the pressure gauge.

Standard value: 1.0 MPa (144 psi)

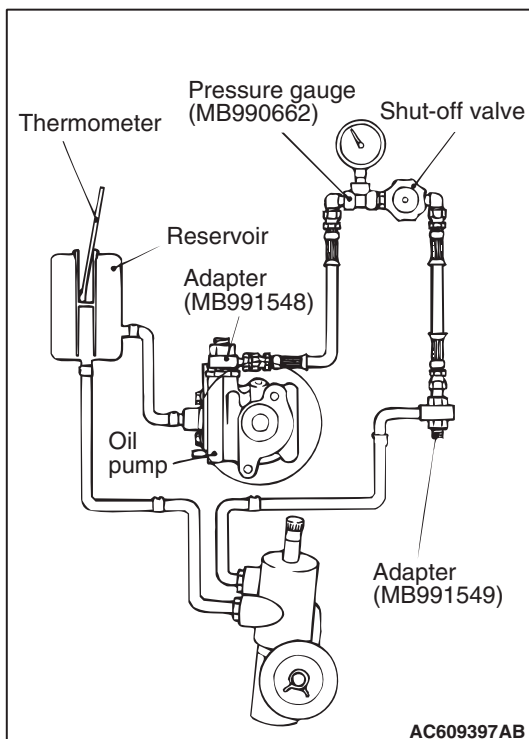

7. If it is not within the standard value, the probable cause is a malfunction of the oil line or steering gear, so check these parts and repair as necessary.
8. Turn the steering wheel all the way to the left or right; then check whether or not the retention hydraulic pressure is the standard value.

Standard value: 8.1 –8.8 MPa (1,174 –1,276 psi)

9. If not the standard value, overhaul the steering gear. Remeasure fluid pressure.
10. Remove the special tools MB991548, MB990662 and MB991549, and then tighten the pressure hose to the specified torque.

Tightening torque: 57 ± 7 N· m (42 ± 5 ft-lb)

11. Bleed the system (Refer to P.37-19).

POWER STEERING PRESSURE SWITCH CHECK

M1372007200647

Required Special Tools:

- MB990662: Power Steering Oil Pressure Gauge
- MB991548: Power Steering Oil Pressure Gauge Adapter (Pump Side)
- MB991549: Power Steering Oil Pressure Gauge Adapter (Hose Side)

1. Disconnect the pressure hose from the oil pump, and then connect the special tools MB991548, MB990662 and MB991549.
2. Bleed air, and then turn the steering wheel several times while the vehicle is not moving so that the temperature of the fluid rises to approximately 50° C –60° C (122° F – 140° F).
3. The engine should be idling.
4. Disconnect the connector for the oil pressure switch, and place an ohmmeter at the switch.
5. Gradually close the shut-off valve of the pressure gauge and increase the hydraulic pressure, then check whether or not the hydraulic pressure that activates the switch is the standard value.

Standard value: 8.1 –8.8 MPa (1,174 –1,276 psi)

6. Gradually open the shut-off valve and reduce the hydraulic pressure; then check whether or not the hydraulic pressure that deactivates the switch is the standard value.

Standard value: 8.1 –8.8 MPa (1,174 –1,276 psi)

7. Remove special tools MB991548, MB990662 and MB991549, connect the pressure hose to the oil pump, and then tighten the eye bolt to the specified torque.

Tightening torque: 57 ± 7 N· m (42 ± 5 ft-lb)

8. Bleed the system. (Refer to P.37-19).

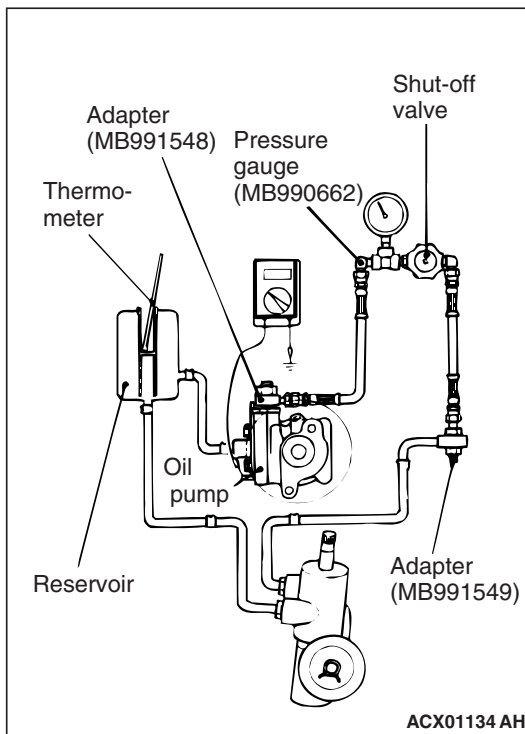

STEERING WHEEL

REMOVAL AND INSTALLATION

M1372011401078

CAUTION

- Before removing the steering wheel assembly and driver's air bag module, always refer to GROUP 52B –Service Precautions P.52B-25 and Air bag Module and Clock Spring P.52B-386.
- After removing the steering wheel, always perform a calibration for the ASC-ECU to learn the steering wheel sensor neutral point. (Refer to GROUP 35C –On-vehicle Service, Steering Wheel Sensor Calibration P.35C-267.)

<p>Pre-removal Operation Steering wheel at straight-ahead position check</p>	<p>Post-installation Operation</p> <ul style="list-style-type: none"> • Steering wheel at straight-ahead position check • Steering wheel looseness check
---	---

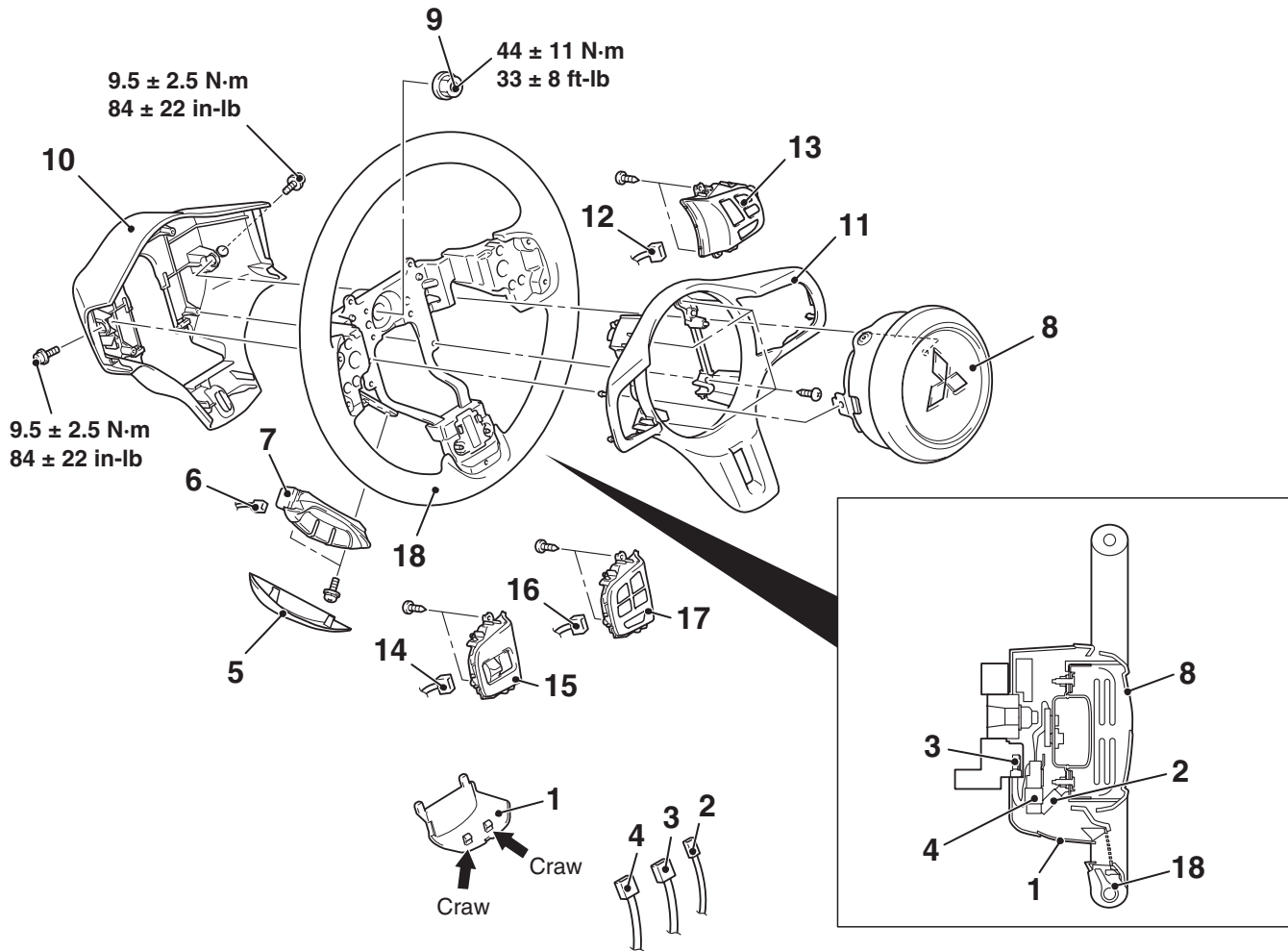

AC708304 AB

- | | | | | | |
|-------|-------|--|-------|-------|--|
| <<A>> | >>B<< | Removal steps | <<C>> | >>A<< | Removal steps (Continued) |
| | >>B<< | 1. Cover | | | 6. Steering wheel voice control switch connector connection |
| | >>B<< | 2. Horn connector connection | | | <Vehicles with steering wheel voice control switch> |
| <> | >>B<< | 3. Steering switch connector connection | | | 7. Steering wheel voice control switch <Vehicles with steering wheel voice control switch> |
| | >>B<< | 4. Driver's air bag module connector connection | | | 8. Driver's air bag module |
| | >>B<< | 5. Steering wheel voice control switch cover <Vehicles with steering wheel voice control switch> | | | 9. Flunge nut |
| | >>B<< | | | | 10. Lower cover |

Removal steps (Continued)

11. Garnish
12. Cruise control switch connector connection
13. Cruise control switch
14. AWC switch connector connection <Except with steering wheel audio remote control switch>
15. AWC switch <Except with steering wheel audio remote control switch>
16. Steering wheel audio remote control switch connector connection <Vehicles with steering wheel audio remote control switch>

Removal steps (Continued)

17. Steering wheel audio remote control switch <Vehicles with steering wheel audio remote control switch>
18. Steering wheel assembly

<<D>> >>A<<

Required Special Tools:

- MB990784: Ornament Remover
- MB990803: Steering wheel puller

REMOVAL SERVICE POINTS

<<A>> COVER REMOVAL

Insert the special tool MB990784 at the indicated position to remove the cover.

NOTE: The special tool MB990784 can be inserted through the notch behind the area shown.

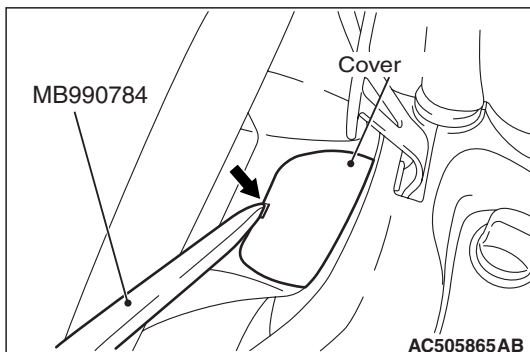

<> AIR BAG MODULE CONNECTOR
CONNECTION REMOVAL

Slide the outer housing of the driver's air bag module connector in the arrow direction shown and disconnect the connector.

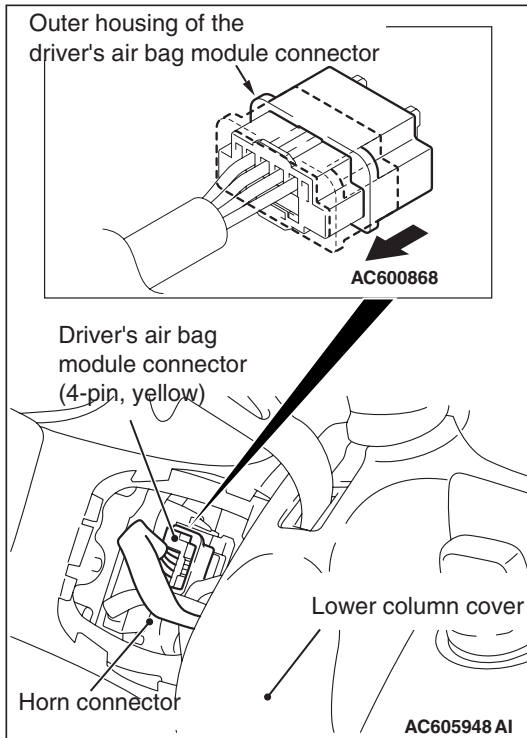

<<C>> DRIVER'S AIR BAG MODULE REMOVAL

⚠ CAUTION

- Never use an electric tester to diagnose the air bag module circuit. Never attempt to disassemble the air bag module.
- Store the removed air bag module in a clean, dry place with the pad surface facing upward.
- When discarding the air bag module, deploy the air bag as specified in the service procedure. (Refer to GROUP 52B –Air bag Module Disposal Procedure P.52B-417.)
- With the driver's air bag module mounting torx screw, loosen the screw, but do not remove it.

Using the torx wrench (T30), remove the driver's air bag module.

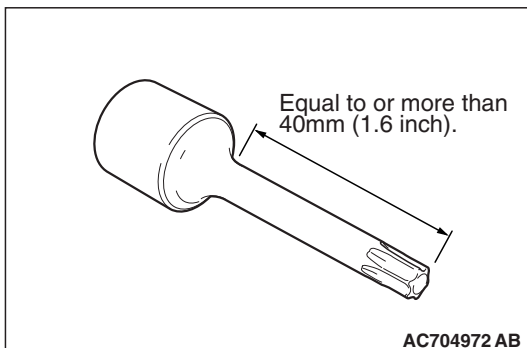

<<D>> STEERING WHEEL ASSEMBLY REMOVAL

1. Position the steering wheel in a straight ahead position.

CAUTION

- Use the special tool to remove the steering wheel since the steering column collision adsorbing mechanism may be damaged.
2. Use special tool MB990803 to remove the steering wheel.

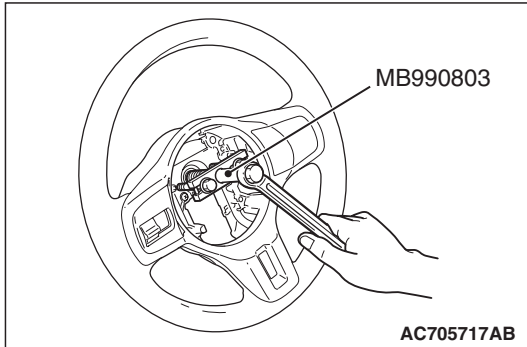

INSTALLATION SERVICE POINTS

>>A<< STEERING WHEEL ASSEMBLY INSTALLATION

After centering the clock spring (Refer to 52B –Air bag module clock spring), install the steering wheel assembly.

>>B<< AIR BAG MODULE CONNECTOR CONNECTION/AUDIO CONTROL SWITCH CONNECTOR CONNECTION/HORN CONNECTOR CONNECTION INSTALLATION

Connect the connector securely and route the harnesses not to lie off the cover hole.

STEERING SHAFT

REMOVAL AND INSTALLATION

M1372011500953

CAUTION

- Before removing the steering wheel assembly and driver's air bag module/knee air bag module, always refer to GROUP 52B –Service Precautions P.52B-25 and Air bag Module and Clock Spring P.52B-386 or Knee Air bag Module P.52B-398.)
- After installation, perform a calibration for the ASC-ECU to learn the steering wheel sensor neutral point. (Refer to GROUP 35C –On-vehicle Service, Steering Wheel Sensor Calibration P.35C-267.)

Pre-removal Operation

- Steering wheel at straight-ahead position check
- Steering wheel assembly removal (Refer to P.37-22.)
- Instrument panel cover lower removal (Refer to GROUP 52A –Instrument Lower Panel P.52A-8.) <MR>
- Knee air bag module removal (Refer to GROUP 52B – Driver's Knee Air Bag Module P.52B-398.)

Post-installation Operation

- Instrument panel cover lower installation (Refer to GROUP 52A –Instrument Lower Panel P.52A-8.) <MR>
- Steering wheel assembly installation (Refer to P.37-22.)
- Steering wheel straight-ahead position check

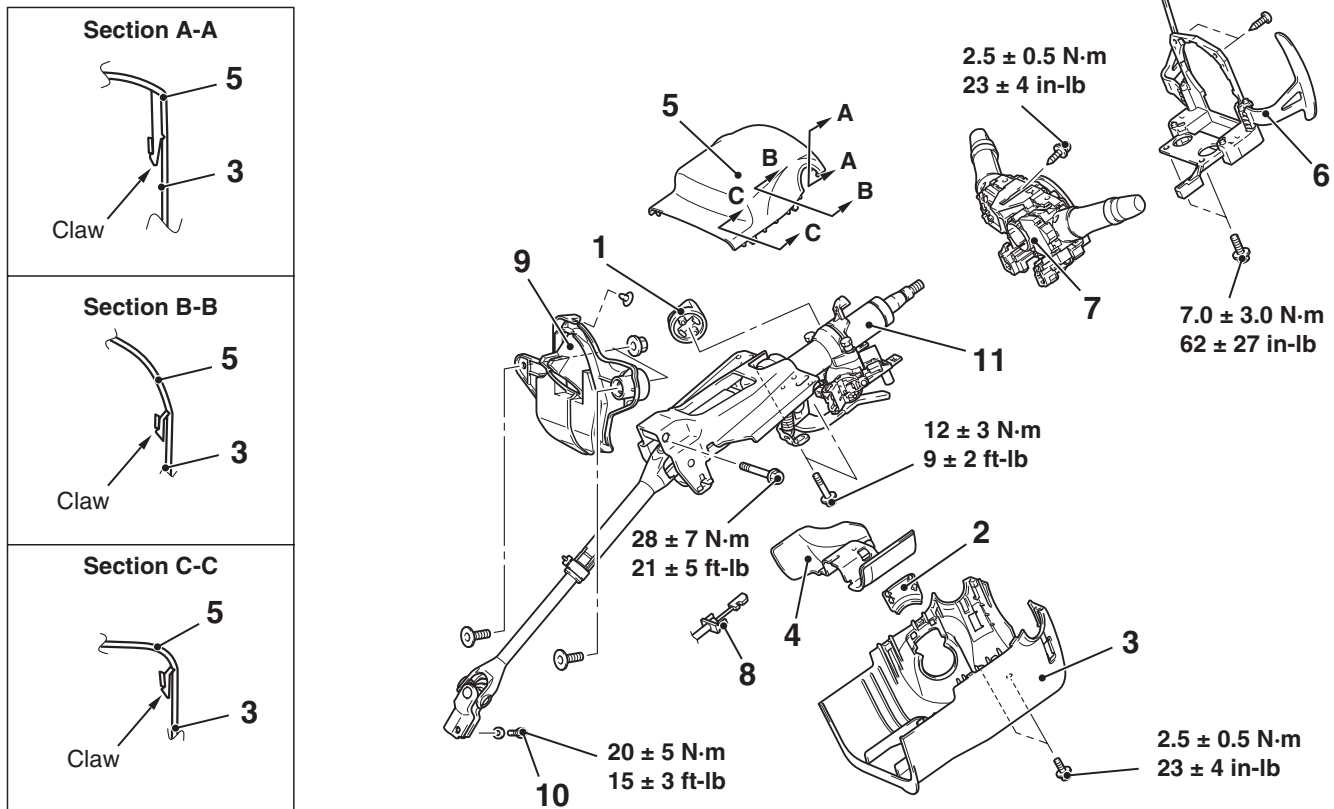

Note: claw position is symmetrical

AC709222 AB

<<A>>

Removal steps

1. Knob cap <Vehicles with KOS>
2. Ignition key cover
3. Steering column lower cover
4. Steering column protector

Removal steps (Continued)

- Receiver antenna module removal (Refer to GROUP 42B –Exterior Transmitter Antenna Assembly, Interior Transmitter Antenna Assembly, Receiver Antenna Module P.42B-279.) <Vehicles with KOS>

Removal steps (Continued)

- WCM removal (Refer to GROUP 42C –WCM P.42C-128.) <Vehicles with WCM>
- 5. Steering column upper cover
- 6. Paddle shift assembly <Vehicles with paddle shift>
- 7. Column switch assembly
- 8. Key interlock cable (Refer to GROUP 22C –Key interlock and shiftlock mechanisms P.22C-337).
- <> 9. Steering shaft cover
- >>B<< 10. Steering column bolt (steering column shaft assembly and steering gear and linkage connection)
- <<C>> >>A<< 11. Steering column shaft assembly

REMOVAL SERVICE POINTS

<<A>> KNOB CAP REMOVAL

Remove the knob cap while pressing the two projections.

<> STEERING SHAFT COVER REMOVAL

1. Remove the clip (for securing the floor carpet), and turn back the floor carpet.
2. Remove the clip (for securing the steering shaft cover), and then remove the steering shaft cover.

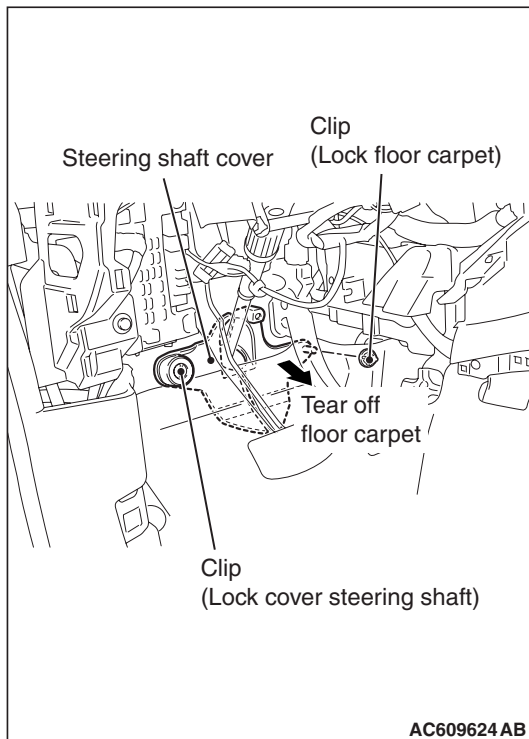

**<<C>> STEERING COLUMN SHAFT ASSEMBLY
DISCONNECTION**

Disconnect the steering gear from the steering column shaft assembly while sliding shaft A to shaft B with the clip claw as shown in the figure being pinched.

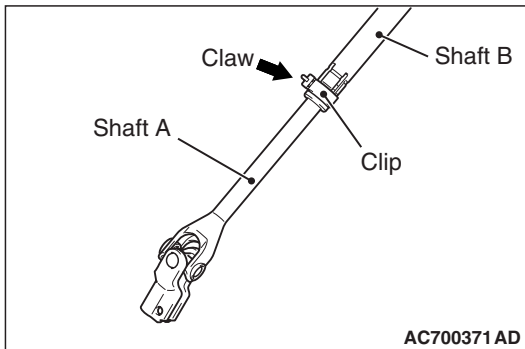
**INSTALLATION SERVICE POINT****>>A<< Steering column shaft assembly installation**

1. Ensure that the tilt lever is in the lock position.
2. Temporarily tighten the mounting bolts in the order of a, b, and c, and then tighten them in the order of c, b, and a to the specified torque.

Tightening torque a: 28 ± 7 N·m (21 ± 5 ft-lb)

Tightening torque b,c: 12 ± 3 N·m (9 ± 2 ft-lb)

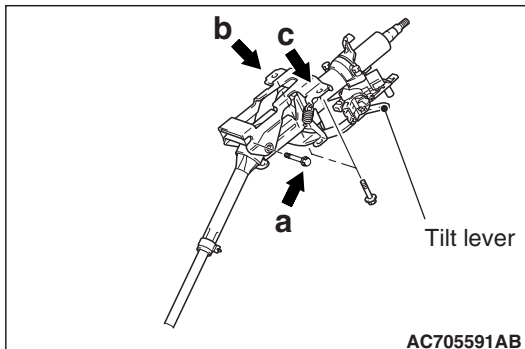

>>B<< Steering column bolt (connection of steering column shaft assembly and steering gear and linkage) installation

1. While sliding shaft A from shaft B with the clip claw as shown in the figure being pinched, connect the steering column shaft assembly and the steering gear and linkage.
2. Insert the steering column bolt from the no tapped bolt hole, and tighten it to the specified torque.

Tightening torque : 20 ± 5 N· m (15 ± 3 ft-lb)

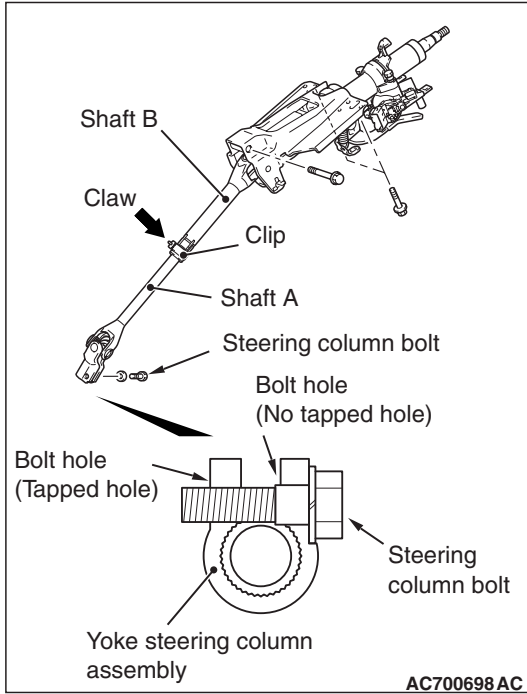

DISASSEMBLY AND REASSEMBLY

M1372011700496

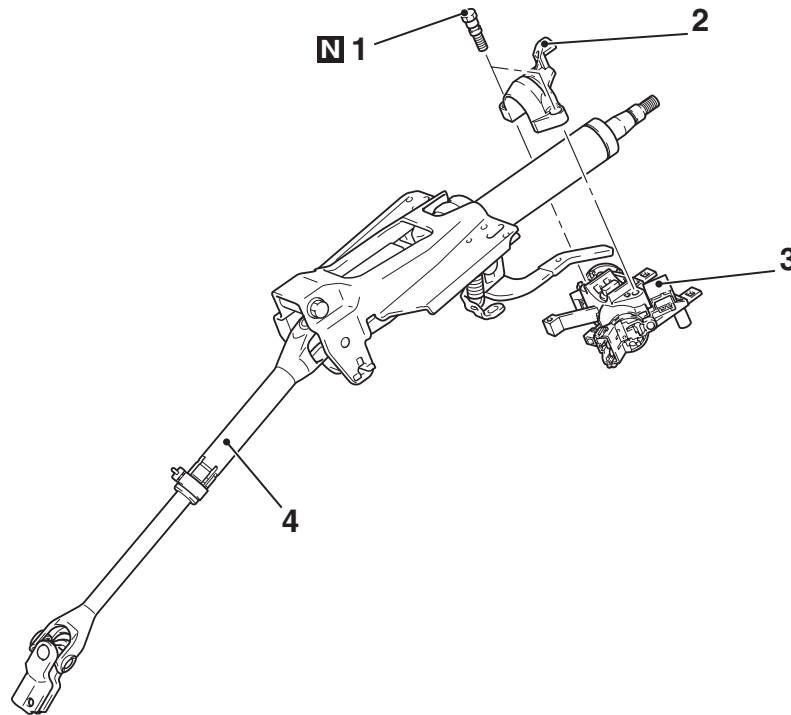

AC704984 AB

<<A>>

>>A<<
>>A<<

Removal steps

1. Steering lock bolt
2. Steering lock bracket

>>A<<

Removal steps (Continued)

3. Steering lock cylinder assembly
4. Steering column shaft assembly

DISASSEMBLY SERVICE POINT**<<A>> STEERING LOCK BOLT REMOVAL**

1. Use a drill to make a hole just deeply enough for the tap to stand on the steering lock bolt.
2. Use a left-hand thread tap to remove the steering lock bolt.

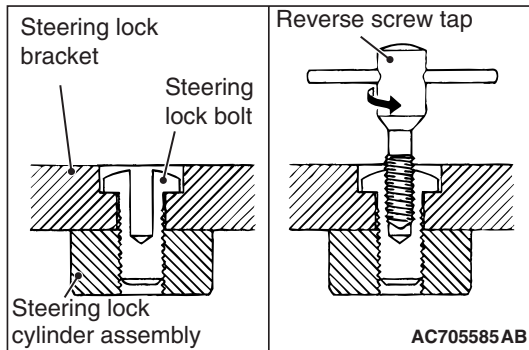
**ASSEMBLY SERVICE POINT****>>A<< STEERING LOCK CYLINDER ASSEMBLY/STEERING LOCK BRACKET/STEERING LOCK BOLT INSTALLATION**

1. When installing the steering lock assembly to the steering column shaft assembly, temporarily assemble the steering lock assembly while aligning it with the boss on the column.
2. Make sure that the steering lock operates normally, and then tighten the steering lock bolt until its head is broken off.

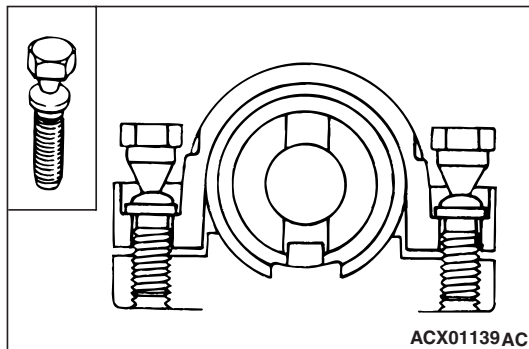

POWER STEERING GEAR BOX AND LINKAGE

REMOVAL AND INSTALLATION

M1372010901285

CAUTION

- Before removing the steering wheel assembly and driver's air bag module, always refer to GROUP 52B –Service Precautions [P.52B-25](#) and Air bag Module and Clock Spring [P.52B-386](#). Also, position the front wheels in a straight ahead direction. If you fail to do this, clock spring for SRS may get damage, making the SRS (air bag) inoperative, and it may cause a serious injury to the driver.
- *: Indicates the bolts and nuts with friction coefficient stabilizer. In removal, ensure there is no damage, clean dust and soiling from bearing and thread surfaces, and tighten them to the specified torque.
- After installation, perform a calibration for the ASC-ECU to learn the steering wheel sensor neutral point. (Refer to GROUP 35C –On-vehicle Service, Steering Wheel Sensor Calibration [P.35C-267](#)).

Pre-removal Operation

- Power steering fluid draining (Refer to [P.37-18](#)).
- Steering wheel and air bag module assembly removal (Refer to [P.37-22](#)).
- Steering shaft cover removal (Refer to [P.37-26](#)).
- Engine room under cover front (A, B) and engine room side cover removal (Refer to GROUP 51 –Under Cover [P.51-16](#)).
- Lower arm removal (Refer to GROUP 33 –Lower Arm [P.33-15](#)).
- Center member and front roll stopper assembly removal (Refer to GROUP 32 –Engine Roll Stopper and Center Member [P.32-10](#)).

Post-installation Operation

- Center member and front roll stopper assembly installation (Refer to GROUP 32 –Engine Roll Stopper and Center Member [P.32-10](#)).
- Lower arm installation (Refer to GROUP 33 –Lower Arm [P.33-15](#)).
- Engine room under cover front (A, B) and engine room side cover installation (Refer to GROUP 51 –Under Cover [P.51-16](#)).
- Steering shaft cover removal (Refer to [P.37-26](#)).
- Steering wheel and air bag module assembly installation (Refer to [P.37-22](#)).
- Using your fingers, press the dust cover of joints to check for a crack or damage.
- Power steering fluid filling (Refer to [P.37-18](#)).
- Air bleeding of power steering fluid (Refer to [P.37-19](#)).
- Steering wheel at straight-ahead position check

**POWER STEERING
POWER STEERING GEAR BOX AND LINKAGE**

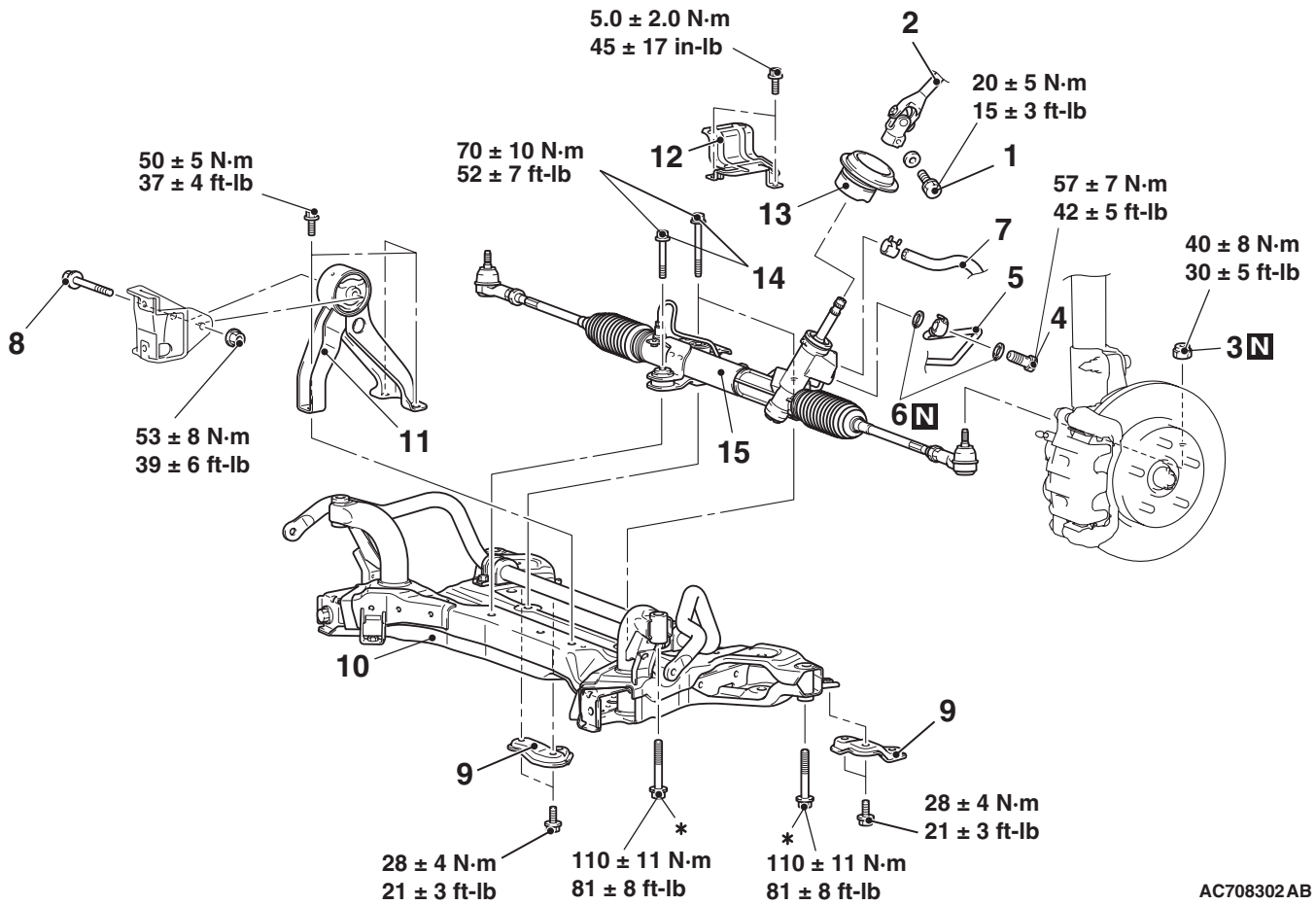

AC708302AB

Removal steps

- >>B<<
1. Steering column bolt (steering column shaft assembly and steering gear and linkage connection)
- <<A>>
2. steering column shaft assembly and steering gear and linkage connection
- <>
3. Self-lock nut (Tie-rod end and knuckle connection)
 4. Eye bolt
 5. Pressure hose connection
 6. Gasket

Removal steps (Continued)

- <<C>>
7. Return hose connection
 8. Engine rear roll stopper bracket connecting bolt
 9. Front axle crossmember stay
 10. Front axle cossmember assembly
 11. Engine rear roll stopper
 12. Heat protector
 13. Joint cover grommet
 14. Flunge bolt
 15. Steering gear and linkage assembly
- >>A<<

REMOVAL SERVICE POINTS

<<A>> DISCONNECTION OF STEERING COLUMN SHAFT ASSEMBLY AND STEERING GEAR AND LINKAGE

Disconnect the steering gear from the steering column shaft assembly while sliding shaft A to shaft B with the clip claw as shown in the figure being pinched.

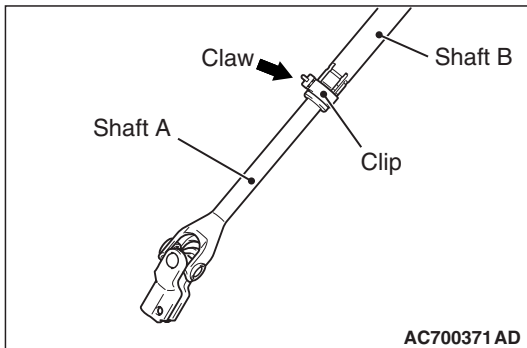

<> SELF-LOCK NUT (TIE-ROD END AND KNUCKLE CONNECTION) REMOVAL

⚠ CAUTION

- Loosen the self-locking nut (tie-rod end connection) from the ball joint, but do not remove here. Use the special tool.
- To prevent the special tool from dropping off, suspend it with a rope.

1. Install special tool MB991897 or MB992011 as shown in the figure.

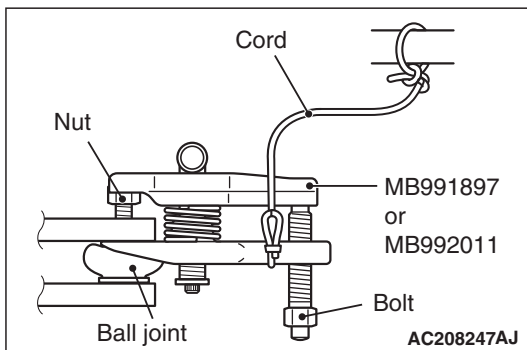

2. Turn the bolt and knob to make the special tool jaws parallel, then hand-tighten the bolt. After tightening, check that the jaws are still parallel.

NOTE: To adjust the special tool jaws to be parallel, set the orientation of the knob as shown in the figure.

3. Unscrew the bolt to disconnect the ball joint.

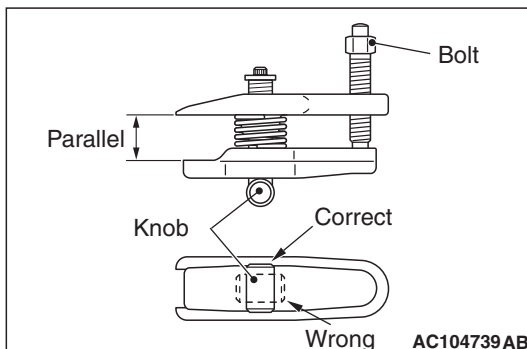

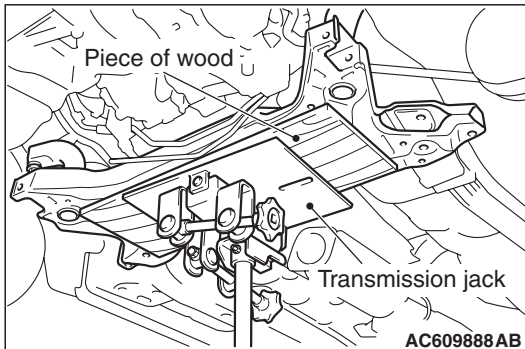
**<<C>> FRONT SUSPENSION CROSSMEMBER
REMOVAL**

1. Jack up and support the crossmember, and remove it.
2. Check the hoses and harnesses for roughness, and then remove the front suspension crossmember with the rear roll stopper and the steering gear and linkage installed.

INSTALLATION SERVICE POINTS**>>A<< JOINT COVER GROMMET INSTALLATION**

Install by aligning the marks of joint cover grommet and steering gear and linkage as shown in the figure.

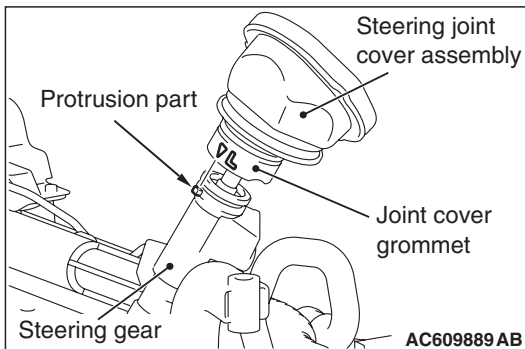
**>>B<< Steering column bolt (connection of steering column shaft assembly and steering gear and linkage) installation**

1. While sliding shaft A from shaft B with the clip claw as shown in the figure being pinched, connect the steering column shaft assembly and the steering gear and linkage.
2. Insert the steering column bolt from the no tapped bolt hole, and tighten it to the specified torque.

Tightening torque : 20 ± 5 N·m (15 ± 3 ft-lb)

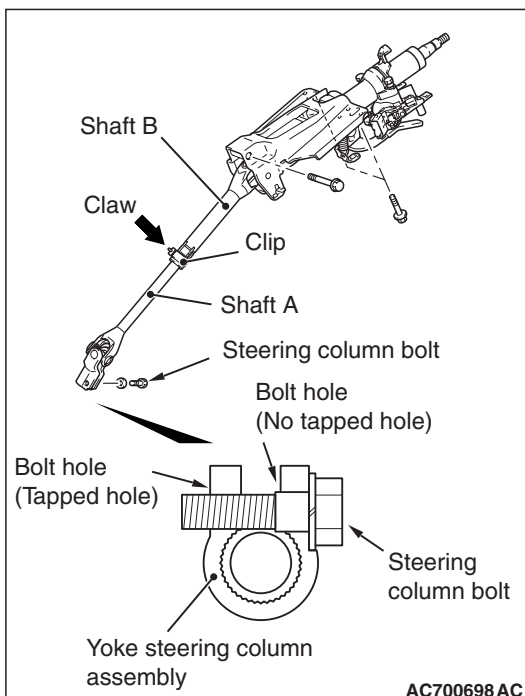

M1372011000992

INSPECTION

PINION TOTAL ROTATION TORQUE CHECK

CAUTION

Secure the steering gear and linkage to the special mounting point. Fixing the steering gear and linkage to another point could deform or damage the gear housing.

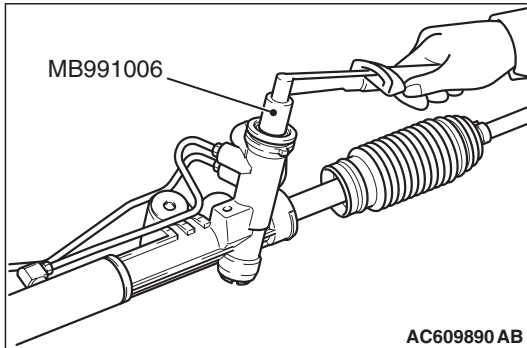

1. Using the special tool preload socket (MB991006) to rotate the pinion at a rate of one turn per 4 to 6 seconds, and then measure the pinion total rotation torque.

Standard value:

Total rotation torque: 0.6 –1.6 N· m (2.6 –7.0 in-lb)

Torque fluctuation: 0.4N· m (1.76 in-lb) or less

NOTE:

- During measurement, remove the bellows from the gear housing.
 - Rotate the pinion by 180° in left and right directions from the neutral position, and measure the pinion total rotation torque.
2. If the measurement value is outside the standard value, replace the gear housing (Refer to P.37-36).

TIE-ROD OSCILLATING TORQUE CHECK

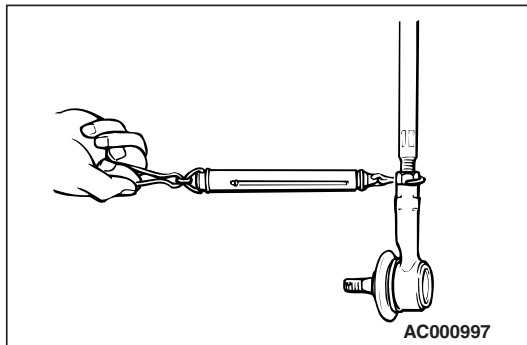

1. Swing the tie-rod ten times strongly.
2. Measure the oscillating resistance (oscillating torque) using a spring scale as shown in the figure with the tie-rod end facing downward.

Standard value:

5 –18 N· m (22 –80 in-lb)

{1.5 –4.9 N· m (13.2 –43.4 in-lb) }

3. If the measurement is greater than the standard value, replace the gear housing (Refer to P.37-36).
4. If the measurement value is below the standard value, check the ball joint for looseness or scraping feeling. If the ball joint swings smoothly, it is judged to be usable.

DISASSEMBLY AND REASSEMBLY

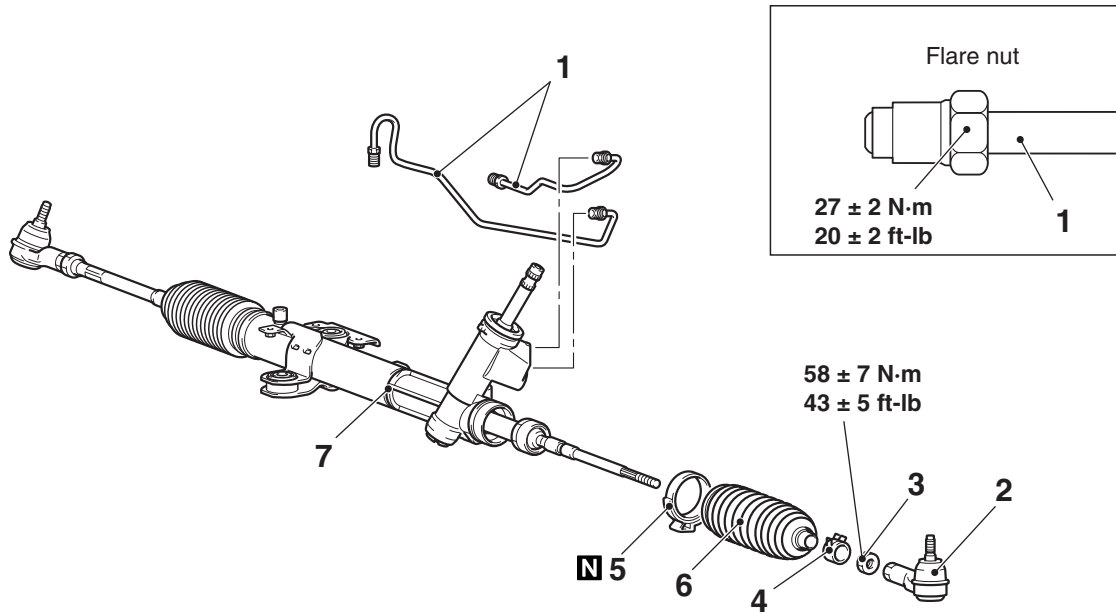

AC708310 AB

- Removal steps**
- >>B<< 1. Feed pipe
 - >>B<< 2. Tie-rod end
 - >>B<< 3. Locking nut
 - >>B<< 4. Clip

- Removal steps (Continued)**
- >>A<< 5. Band
 - 6. Bellows
 - 7. Gear housing

LUBRICATION AND SEALING POINTS

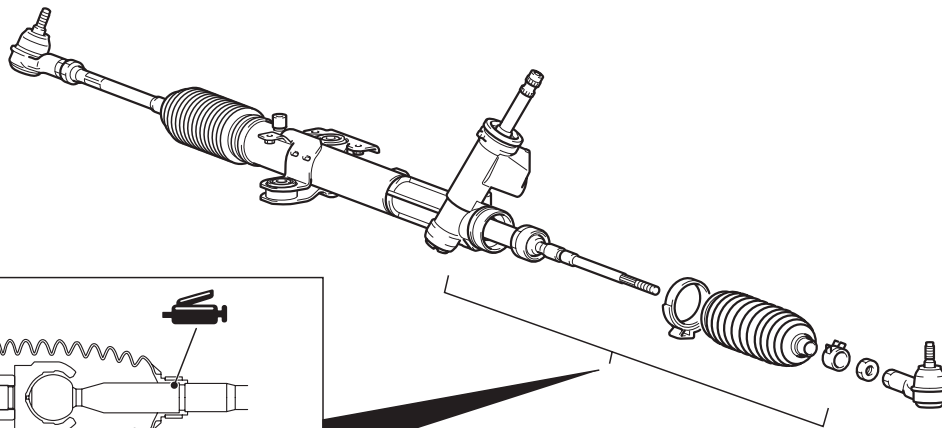

Sealant: 3M™ AAD Part No. 8663 or equivalent
Grease: Silicone grease

AC709293 AB

ASSEMBLY SERVICE POINT

>>A<< BAND INSTALLATION

⚠ CAUTION

- Secure the rack housing, and firmly crimp the bellows band by the bellows band clipping tool (special tool: MB992209).
 - Crimp the bellows band securely until the special tool (MB992209) contacts the stopper.
1. Using the special tool (MB992209), crimp the bellows band.

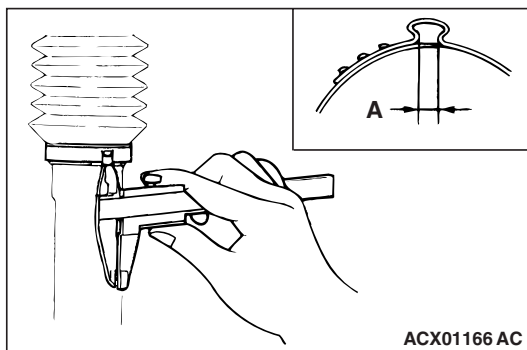
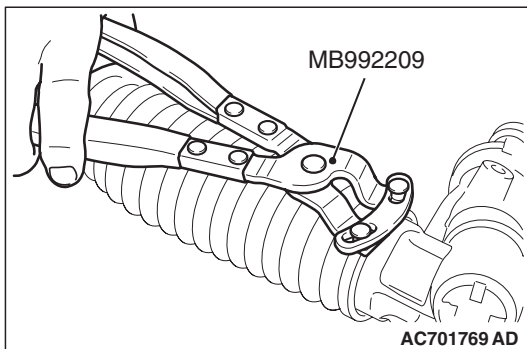

2. Check that the crimping width of the band (A) is within the range of the standard value.

Standard value (A): 2.4 –2.8 mm (0.09 –0.11 in)

>>B<< TIE-ROD END/LOCKING NUT INSTALLATION

Screw in the tie-rod to the length shown in the figure, and hand-tighten the locking nut.

NOTE: Install the steering gear and linkage to the body, adjust the toe-in, and then tighten the locking nut to the specified torque.

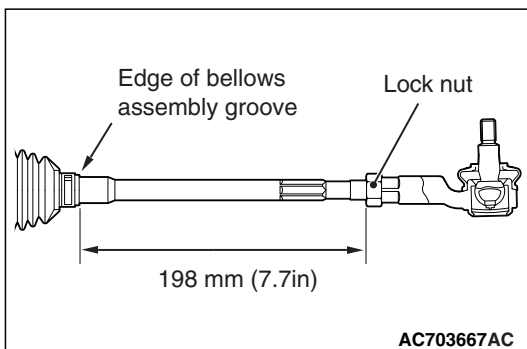

POWER STEERING OIL PUMP ASSEMBLY

REMOVAL AND INSTALLATION

M1372005201172

Pre-removal Operation

- Power steering fluid draining (Refer to P.37-18.)
- Engine upper cover removal (Refer to GROUP 11A – Camshaft P.11A-25.)
- Radiator condenser tank removal (Refer to GROUP 14 – Radiator P.14-31.)

Post-installation Operation

- Radiator condenser tank installation (Refer to GROUP 14 –Radiator P.14-31.)
- Engine upper cover installation (Refer to GROUP 11A – Camshaft P.11A-25.)
- Drive belt tension adjustment (Refer to GROUP 11A – Engine Adjustment, and Drive Belt Tension Check and Adjustment P.11A-8.)
- Power steering fluid refilling and bleeding (Refer to P.37-19.)

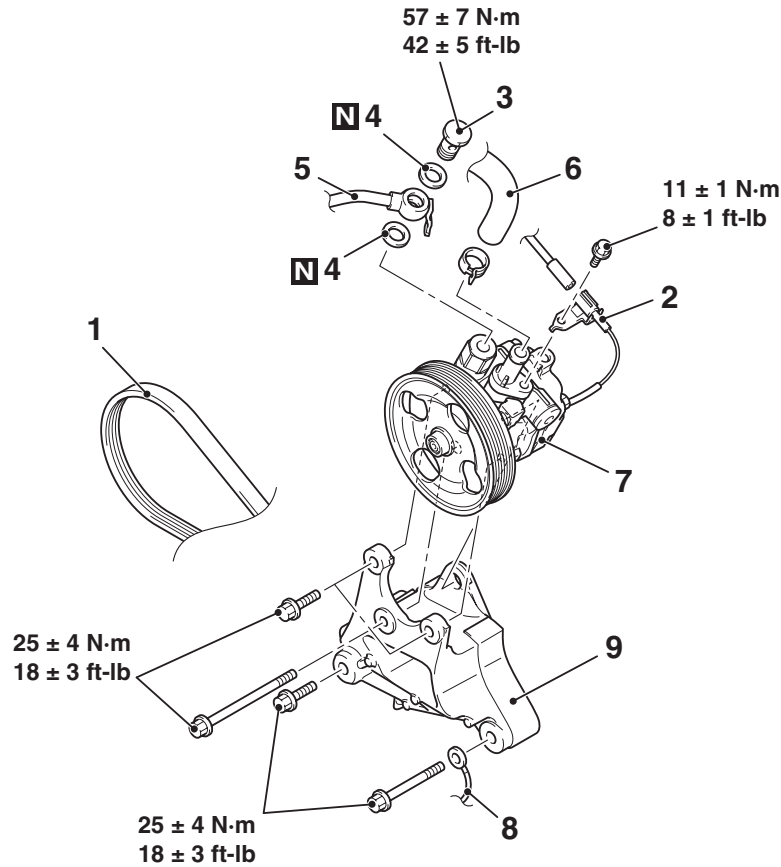

AC704977AB

Removal steps

1. Generator and others belt (Refer to GROUP 11A – Crankshaft Pulley Removal and Installation P.11A-21).
2. Pressure switch connector connection
3. Eye bolt

Removal steps (Continued)

4. Gasket
5. Pressure hose assembly connection
6. Suction hose connection
7. Oil pump assembly
8. Ground connection
9. Oil pump bracket

>>A<<

INSTALLATION SERVICE POINT

>>A<< SUCTION HOSE INSTALLATION

Install the suction hose with its marking located as shown in the figure.

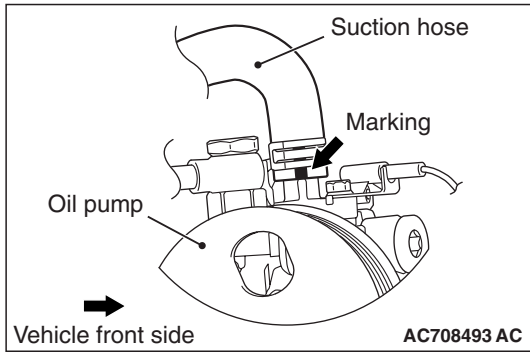

POWER STEERING HOSES

REMOVAL AND INSTALLATION

M1372005701382

Pre-removal Operation

- Power steering fluid draining (Refer to P.37-18.)
- Front bumper assembly removal (Refer to GROUP 51, Front Bumper Assembly and Radiator Grille P.51-3.)
- Headlight (RH) removal (Refer to GROUP 54A P.54A-184 Headlight.)
- Strut tower bar removal (Refer to GROUP 42A P.42A-15 Strut Tower Bar.)
- Engine upper cover removal (Refer to GROUP 11A – Camshaft P.11A-25.)

Post-installation Operation

- Strut tower bar installation (Refer to GROUP 42A –Strut Tower Bar P.42A-15.)
- Headlight (RH) installation (Refer to GROUP 54A –Headlight P.54A-184.)
- Front bumper assembly installation (Refer to GROUP 51 – Front Bumper Assembly and Radiator Grille P.51-3.)
- Power steering fluid refilling and bleeding (Refer to P.37-19.)
- Engine upper cover installation (Refer to GROUP 11A – Camshaft P.11A-25.)

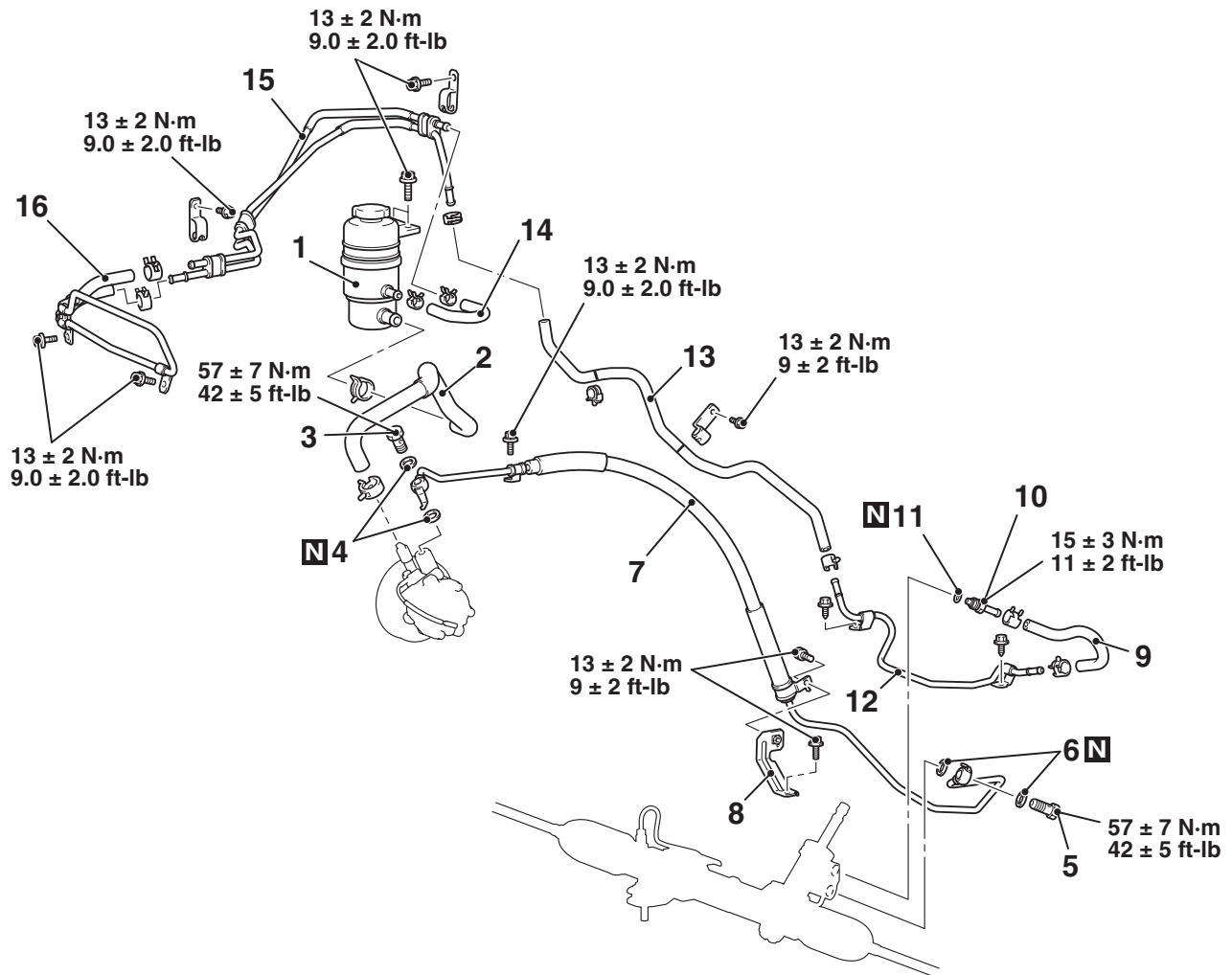

AC708301AB

Removal steps

- >>D<<
1. Oil reservoir
 2. Suction hose
 3. Eye bolt
 4. Gasket
 5. Eye bolt
 6. Gasket
- >>C<<
7. Pressure hose
 8. Pressure hose bracket

>>B<<

>>A<<

>>B<<

>>B<<

>>A<<

>>A<<

Removal steps (Continued)

9. Return hose
10. Return tube
11. Gasket
12. Return tube
13. Return hose
14. Return hose
15. Return tube
16. Cooler tube assembly

INSTALLATION SERVICE POINTS

>>A<< COOLER TUBE ASSEMBLY/RETURN TUBE ASSEMBLY INSTALLATION

Install by aligning the mating marks of cooler tube assembly and return tube assembly.

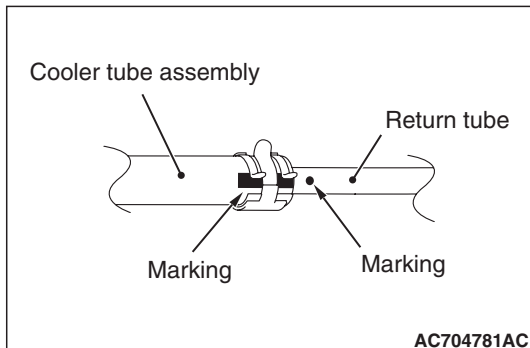

>>B<< RETURN HOSE INSTALLATION

1. Install the return hose by aligning the mating marks.

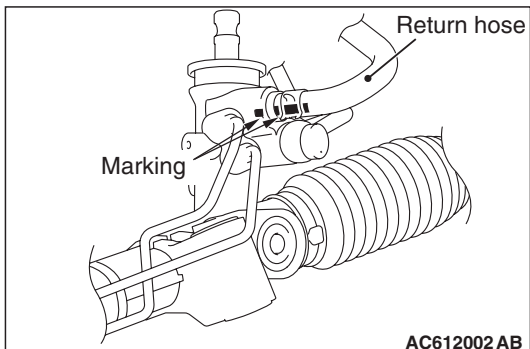

2. Install the return hose with its marking located as shown in the figure.

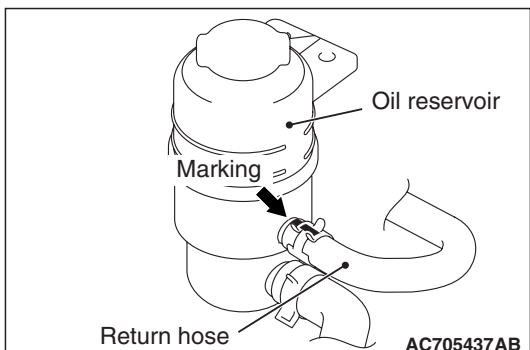

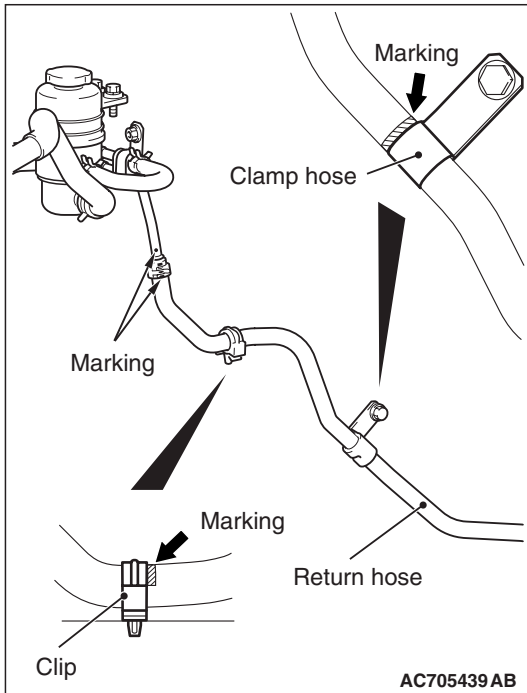

- Using clips and hose clamps, install the return hose with its marking located as shown in the figure.

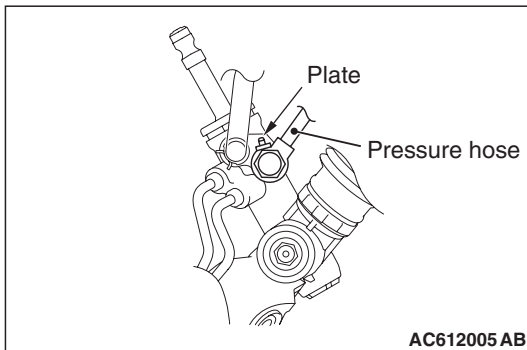

>>C<< PRESSURE HOSE INSTALLATION

Install the pressure hose plate with its marking located as shown in the figure.

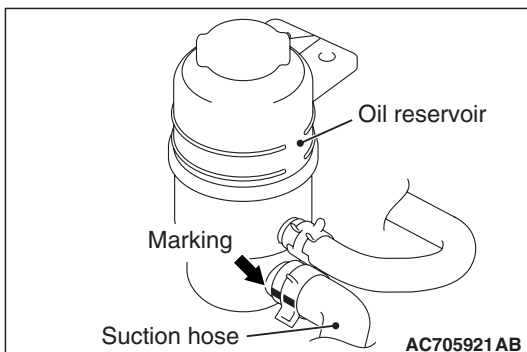

>>D<< SUCTION HOSE INSTALLATION

- Install the suction hose with its marking located as shown in the figure.

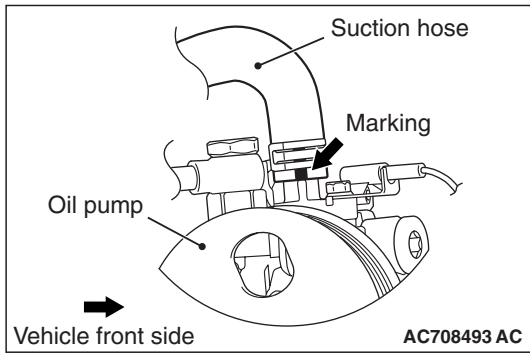

2. Install the suction hose with its marking located as shown in the figure.

NOTES