



**OWNERS SERVICE MANUAL  
NO. 05605  
INSTALLATION, OPERATING & SERVICING INSTRUCTIONS**

**Wheeled**

Models 450, 451, 452 ( 25 Cu. Ft. Nitrogen Cylinder 16" wheels)

Models 467, 468, 469 (110 Cu. Ft. Nitrogen Cylinder 16" wheels)

Models 470, 471, 472 (110 Cu. Ft. Nitrogen Cylinder 36" wheels)

**Stationary**

Models 481, 482, 483 ( 23 Cu. Ft. Nitrogen Cylinder)

Models 484, 485, 486 (110 Cu. Ft. Nitrogen Cylinder)

All fire extinguishers should be installed, inspected and maintained in accordance with the National Fire Protection Association standard titled "Portable Fire Extinguishers", NFPA-10 and the requirements of local authorities having jurisdiction.

When maintenance is indicated it should be performed by trained persons having proper equipment. Fire extinguishers are pressure vessels and must be treated with respect and handled with care. They are mechanical devices and require periodic maintenance to be sure that they are ready to operate properly and safely. Amerex strongly recommends that the maintenance of portable fire extinguishers be done by a trained professional – your local authorized Amerex Distributor.

Amerex Corporation makes original factory parts available to insure proper maintenance – **USE OF SUBSTITUTE PARTS RELEASES AMEREX OF ITS WARRANTY OBLIGATIONS.** Amerex parts have machined surfaces and threads that are manufactured to exacting tolerances. O-rings, hoses, nozzles, and all metal parts meet precise specifications and are subjected to multiple in-house inspections and tests for acceptability. There are substitute parts available that may be incorrectly labeled as UL component parts, some are advertised as Amerex type. None of these meet UL requirements and all of them void the Amerex extinguisher warranty and UL listing. **DO NOT SUBSTITUTE.**

**RECHARGE FIRE EXTINGUISHERS IMMEDIATELY AFTER ANY USE**

**REFERENCES IN THIS MANUAL:**

**NFPA-10** Portable Fire Extinguishers

**CGA C-1** Methods for Hydrostatic Testing of Compressed Gas Cylinders

**CGA C-6** Standard for Visual Inspection of Compressed Gas Cylinders

**AVAILABLE FROM:**

National Fire Protection Association  
1 Batterymarch Park, P.O. Box 9101  
Quincy, MA 02269-9101

Compressed Gas Association, Inc.  
4221 Walney Road, 5<sup>th</sup> Floor  
Chantilly, VA 20151-2923

**AMEREX CORPORATION – P.O. BOX 81 – TRUSSVILLE, ALABAMA 35173-0081**

**Phone: 205/655-3271 Fax: 800/654-5980**

**e-mail: [sales@amerex-fire.com](mailto:sales@amerex-fire.com) Web Page: <http://www.amerex-fire.com>**

## INTRODUCTION

**THIS MANUAL IS ATTACHED TO EVERY NEW EXTINGUISHER SHIPPED FROM THE FACTORY. IT CONTAINS VALUABLE INFORMATION WHICH SHOULD BE STUDIED BY EVERYONE WHO WILL USE OR SERVICE THE EXTINGUISHER. THE MANUAL SHOULD BE STORED IN A CONVENIENT LOCATION FOR EASY REFERENCE.**

### PREPARING YOUR NEW EXTINGUISHER FOR USE

**WARNING: THIS FIRE EXTINGUISHER IS SHIPPED FROM THE FACTORY EMPTY. AFTER INITIAL PREPARATIONS, CAREFULLY FOLLOW THE RECHARGING INSTRUCTIONS BEFORE PLACING IT INTO SERVICE.**

1. Remove all wrappings, straps and pallet retaining bolts.
2. Examine the extinguisher for shipping damage. Check to make sure that you have received the dry chemical charges that are shipped with the extinguisher (ABC and PURPLE K (two) 2 - 50 lb. pails and 1 (one) 25 lb. pail; REGULAR – three (3) 50 lb. pails).
3. Fill the extinguisher by carefully following the Recharge instructions.
4. Remove the nitrogen cylinder protective shipping cap. Save the cap as it must be installed whenever a charged nitrogen cylinder is transported. Remove temporary (shipping) ring pin and install large ring pin.
5. Install new lockwire seal. Check the nitrogen cylinder pressure. The gauge should read approximately 2015 psig (13.9 mPa) at 70°F (21°C) ambient temperature. See the "Troubleshooting Guide" for pressure-temperature allowances. The lockwire seal should be intact.
6. Remove (and save) the Safety Vent Plug installed on all "T" handle nitrogen valves. Connect the nitrogen supply hose firmly to the nitrogen cylinder valve. Make sure that there are no kinks in this hose.
7. Disconnect the discharge hose assembly from the agent cylinder. Make sure that the hose and nozzle are unobstructed and that the Moisture Seal is undamaged and properly seated on the agent cylinder discharge fitting. Reconnect the discharge hose to the agent cylinder and with the nozzle in the closed (forward) position, place it on the storage rack. (See Page 11 )
8. Record the date the unit is being placed into service on the inspection tag and attach it to the extinguisher.
9. Remove the caution (not charged) tag.

## INSTALLATION

### **WARNING: DO NOT PLACE THIS EXTINGUISHER CLOSE TO A POTENTIAL FIRE**

Do not place this extinguisher close to a potential fire hazard. Amerex recommends location no less than a 50 foot distance from the hazard while leaving an unobstructed access. Avoid placing it in an extremely hot or cold place. The operational temperature range for this extinguisher is -65°F to +120°F (-54°C to +49°C). The extinguisher should be adequately protected if temperatures outside of this range are anticipated. Keep the extinguisher clean and free from dirt, ice, chemicals and any contaminants that may interfere with its proper operation. **DO NOT FUNCTIONALLY TEST THIS FIRE EXTINGUISHER.** (Testing or any use may cause the extinguisher to gradually lose pressure over a period of time and make the extinguisher ineffective.)

## OPERATION

**NOTE: Persons expected to use this extinguisher should be trained in initiating its operation and in the proper fire fighting technique. Familiarize all personnel with this information before an emergency occurs.**

1. Move the extinguisher to within approximately 50 feet of the fire site and keep extinguisher upright. Remove ring (safety) pin and pull "T" handle to open argon cylinder valve. This will pressurize the extinguisher.
2. Remove nozzle from the mount, and with the nozzle lever in the closed position, pull hose from rack.
3. Start back 20 feet from the fire and aim at base of fire nearest you.
4. Open hose and nozzle firmly and be prepared for discharge recoil. Open nozzle by pulling the handle fully toward you. Slowly sweep side to side across the base of the fire and past both edges. Progressively follow up until the fire is extinguished.

**DISCHARGE TIME (APPROXIMATE) - See extinguisher nameplate (label)**  
**EFFECTIVE RANGE OF THE AGENT THROW - 25 to 40 feet**  
**HOSE LENGTH – 50 feet**

### **RECHARGE FIRE EXTINGUISHERS IMMEDIATELY AFTER ANY USE**

## SHUTDOWN

1. After making sure that the fire has been completely extinguished, close the nozzle valve and then close nitrogen cylinder valve (push "T" handle to closed position). **Wheeled Extinguisher** – Tip over until it rests on both wheels and handle (in this position much of the remaining chemical will stay in the cylinder). **Stationary Extinguisher** – see instructions below.
2. Open the nozzle valve slowly to clear the hose of any remaining pressure and chemical (be prepared for recoil and discharge of agent).

**WARNING: MAKE SURE THAT ALL PRESSURE HAS ESCAPED BEFORE ANY FURTHER DISASSEMBLY.**

3. Stand unit upright after complete depressurization.

**NOTE:** Nitrogen pressure in the agent cylinder cannot escape through a disconnected nitrogen hose assembly due to a check valve in the system. **Always be careful when removing the fill cap.**

4. Coil the extinguisher hose onto the storage rack and position the nozzle onto the mount in preparation for transport to the recharge location.

**CAUTION: DO NOT TRANSPORT A NITROGEN CYLINDER WITHOUT INSTALLING THE PROTECTIVE SHIPPING CAP.**

## VENTING DEVICE

(**Standard** on all Stationary Extinguishers, **Optional** on Wheeled Extinguishers)

A venting device has been installed on all stationary extinguishers to provide a means of safely and easily relieving residual argon pressure from the agent cylinder while utilizing the same pressure to evacuate or "blow down" the hose.

See Below: Figure 1 – Models 484, 485 & 486 (Tall Units – 110 cu. ft. Nitrogen Cylinder)  
Figure 2 – Models 481, 482 & 483 (Short Units – 23 cu. ft. Nitrogen Cylinder)

**OPERATION** – After the fire has been successfully extinguished and it has been determined that it is completely out:

1. Confirm that the nozzle lever is in the CLOSED position.
2. Close the argon valve (move "T" handle to CLOSED position)
3. Remove ring pin and CLOSE agent cylinder valve (Valve A in Fig. 1) to prevent further chemical from entering the hose.
4. Remove ring pin and OPEN pressure vent valve (Valve B in Fig. 1) to allow argon gas to by-pass the chemical and pressurize the hose.
5. Open discharge nozzle to vent all residual chemical and nitrogen gas pressure.
6. Re-open nitrogen valve if additional pressure is required.
7. When recharging this unit, reset agent cylinder and vent valves, install ring pins and lockwire seals.

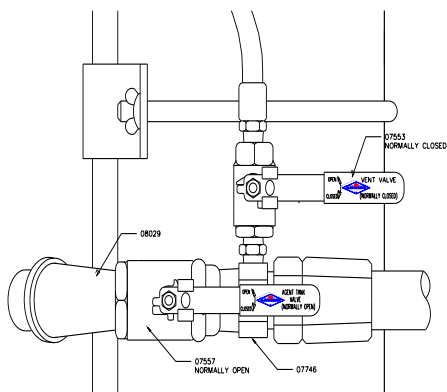

**Figure 1**

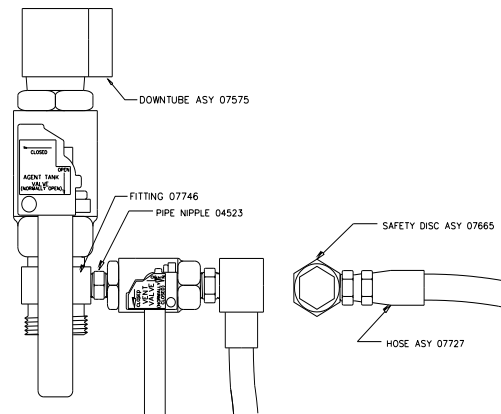

**Figure 2**

**CAUTION: VALVE SHUT-OFF HANDLES MUST BE IN THE POSITIONS SHOWN WHEN EXTINGUISHER IS ON STANDBY OR IN ACTUAL OPERATION.**

**AMEREX CORPORATION DOES NOT SERVICE, MAINTAIN OR RECHARGE FIRE EXTINGUISHERS. THIS MANUAL IS PUBLISHED AS A GUIDE TO ASSIST QUALIFIED SERVICE PERSONNEL IN THE INSPECTION, MAINTENANCE AND RECHARGE OF AMEREX FIRE EXTINGUISHERS ONLY. NO INSTRUCTION MANUAL CAN ANTICIPATE ALL POSSIBLE MALFUNCTIONS THAT MAY BE ENCOUNTERED IN THE SERVICE OF FIRE EXTINGUISHERS. DUE TO THE POSSIBILITY THAT PRIOR SERVICE PERFORMED ON THIS EQUIPMENT MAY HAVE BEEN IMPROPERLY DONE, IT IS EXTREMELY IMPORTANT THAT ALL WARNINGS, CAUTIONS AND NOTES IN THIS MANUAL BE CAREFULLY OBSERVED. FAILURE TO HEED THESE INSTRUCTIONS COULD RESULT IN SERIOUS INJURY.**

**AMEREX ASSUMES NO LIABILITY FOR SERVICE, MAINTENANCE OR RECHARGE OF FIRE EXTINGUISHERS BY PUBLISHING THIS MANUAL.**

## **INSPECTING THE EXTINGUISHER**

NFPA 10 - This extinguisher should be inspected at regular intervals (monthly or more often if circumstances dictate) to insure that it is ready for use. (NFPA 10) Inspection is a "quick check" that a fire extinguisher is available and is in operating condition. It is intended to give reasonable assurance that the fire extinguisher is fully charged. This is done by verifying that it is in its designated place, that it has not been actuated or tampered with, and that there is no obvious physical damage or condition to prevent its operation.

**PERIODIC INSPECTION PROCEDURES** (Monthly or more often if circumstances dictate) A "quick check" should be made of the extinguisher for the following:

1. Located in designated place.
2. No obstructions to access or visibility.
3. Operating instructions on nameplate and facing outward.
4. Seals and tamper indicators not broken or missing.
5. Determine fullness by weighing (full weight is noted on the nameplate [label]).
6. Examine for obvious physical damage, corrosion, leakage or clogged nozzle.
7. Pressure gauge (nitrogen cylinder) reading in operable area.
8. Condition of tires & wheels, carriage, hose and nozzle.

## **MAINTENANCE**

At least once a year or more frequently if circumstances require, maintenance should be performed. Maintenance is a "thorough check" of the extinguisher. It is intended to give maximum assurance that a fire extinguisher will operate effectively and safely. It includes a thorough examination for physical damage or condition to prevent its operation and any necessary repair or replacement. It will normally reveal if hydrostatic testing.

**NOTE:** NFPA-10 spells out wheeled extinguisher maintenance procedures. NFPA requires that regulators on wheeled extinguishers be checked annually to meet manufacturer's "dead set" and "minimum flow" recommendations. This information is provided in a special section on page 6 (R-a thru R-d) for Amerex Regulated Wheeled Models 467, 468, 469, 470, 471 & 472 and Regulated Stationary Models 484, 485 and 486.

**NOTE:** The Getz Manufacturing Universal Wheeled Extinguisher Service Kit is available so that NFPA-10 required maintenance functions can be performed.

## ANNUAL MAINTENANCE – SERVICE PROCEDURE

**WARNING: BEFORE SERVICING, BE SURE THE EXTINGUISHER AGENT CYLINDER IS NOT PRESSURIZED. THIS PROCEDURE IS BEST ACCOMPLISHED WITH THE EXTINGUISHER IN AN UPRIGHT POSITION AND ON A LEVEL SURFACE.**

1. Clean extinguisher to remove dirt, grease or foreign material. Check to make sure that the instruction nameplate is securely fastened and legible. Inspect the cylinders for corrosion, abrasion, dents or weld damage. If any damage is found, hydrostatically test in accordance with instructions in CGA C-1 and C-6 and NFPA 10.
2. Inspect the extinguisher for damaged, missing or substitute parts. A careful inspection should be made of the safety relief (MODELS 450, 451 & 452) to make sure that it has not ruptured, corroded or been tampered with. ONLY FACTORY REPLACEMENT PARTS ARE APPROVED FOR USE ON AMEREX FIRE EXTINGUISHERS.
3. Check the date of manufacture printed on the extinguisher label (nameplate) or on the agent cylinder dome. The agent cylinder, the discharge hose assembly and nitrogen supply hose must be hydrostatically tested every 12 years. Test pressure:
  - a. Agent Cylinder – 500 psi (3447 kPa)
  - b. Hose Assembly – 300 psi (2068 kPa)
4. Check the hydrostatic test date on the crown of the nitrogen cylinder. The nitrogen cylinder must be retested in accordance with DOT regulations.
5. Check the gauge on the nitrogen cylinder. If the pressure is below 1700 psig (11.7 mPa) repressurize the cylinder to 2015 psig (13.9 mPa) or replace it. A low gauge pressure may indicate leakage. Check for leaks. A low gauge reading may also result from low temperature. See the temperature/pressure relationship chart in the Troubleshooting Guide. Check the tamper indicator (lockwire seal) on the argon valve and replace if necessary.
6. Wheeled extinguishers – Inspect the wheels to insure they rotate freely. Lubricate as required.

**WARNING: THE FOLLOWING STEPS SHOULD ONLY BE PERFORMED BY PROFESSIONALLY TRAINED AND QUALIFIED SERVICE PERSONNEL THOROUGHLY FAMILIAR WITH INDUSTRY SERVICE PROCEDURES AND SAFETY PRECAUTIONS AND HAVING THE NECESSARY EQUIPMENT TO PERFORM THE SERVICE PROPERLY. ALL EXTINGUISHER AND SERVICE EQUIPMENT COMPONENTS, FITTINGS AND ADAPTERS MUST BE IN GOOD CONDITON AND PROPERLY CONNECTED.**

## MAINTENANCE OF REGULATED WHEELED EXTINGUISHERS

NOTE: Steps R-a thru R-d apply to models with a Regulator. These procedures should be performed only by professionally trained and qualified service personnel thoroughly familiar with industry service procedures and safety precautions. All extinguisher and service equipment components, fittings and adapters must be in good condition and properly connected.

R-a. Disconnect the regulator from the agent cylinder. Visually examine the regulator and high pressure hose for signs of damage, corrosion or deterioration. To perform the regulator static pressure, dead set and minimum pressure flow rate checks. Connect the proper hose service kit Adapter (P/N 01740) to the low pressure outlet port of the regulator. Connect the service kit Hose Assembly (P/N 01410) and Flow Chamber (P/N 01250) to the regulator low pressure port adapter.

R-b. Make sure all service kit connections are secure and that the kit flow chamber valve is **closed**. Check nitrogen cylinder pressure to ensure that it is within the acceptable operating pressure range. Hold the kit flow chamber in one hand and slowly open the nitrogen cylinder (with either the "T" handle operating lever or by turning the handwheel if so equipped). Observe flow chamber pressure reading to see if it is within the specified static dead set pressure parameters noted below. The only type regulators used on Amerex dry chemical regulated wheeled extinguishers were Victor and MECO. Also see Amerex Tech Tip for Class D Dry Powder Wheeled Extinguisher Pressures.

| Regulator Type | Model No. | Static Dead Set Pressure | Minimum Flow Pressure |
|----------------|-----------|--------------------------|-----------------------|
| Victor         | SR-450L   | 225 – 245 psi            | 140 psi               |
| MECO           | P-600     | 235 – 255 psi            | 140 psi               |
| Victor         | SR-450E   | 225 – 245 psi            | 140 psi               |

**WARNING: IF THE PRESSURE READING EXCEEDS THE GIVEN PARAMETERS, QUICKLY CLOSE THE NITROGEN CYLINDER "T" HANDLE OR HANDWHEEL VALVE AND VENT THE PRESSURE BY OPENING THE FLOW CHAMBER BALL VALVE. REGULATORS CANNOT BE FIELD ADJUSTED – THEY MUST BE REPLACED IF FOUND TO BE OUT OF TOLERANCE.**

R-c. Observe the proper regulator static dead set pressure for a minimum of one minute – then fully open the flow chamber valve for 1-2 seconds and observe the pressure reading to ensure that the flow pressure does not drop below the minimum specified. Close the nitrogen cylinder valve after the test and vent the flow chamber pressure by opening the flow chamber valve.

NOTE: Prior to performing minimum flow check, make sure that the nitrogen cylinder valve ("T" handle or handwheel) is FULLY OPEN so that it does not restrict or alter the flow readings.

R-d. Disconnect the service kit quick connect adapter from the low pressure regulator and reinstall the regulator securely to the agent cylinder. (THIS STEP IS FOR REGULATED EXTINGUISHERS ONLY)

7. Disconnect the discharge hose from the agent cylinder. Check the couplings, hose and hose gaskets for damage or deterioration – replace as necessary.
8. To perform an operational integrity check on the discharge hose and nozzle combination:
  - a. Connect the test kit hose adapter to the female end of the discharge hose.
  - b. Connect the discharge nozzle shut-off lever and properly secure it.
  - c. Connect a properly regulated and verified nitrogen pressure source (set to the extinguisher operating pressure (235-245 psi) to the test kit hose adapter.
  - d. Slowly pressurize the discharge hose/nozzle assembly to the extinguisher operating pressure and check for leaks or distortion.

- e. Operate the nozzle lever to ensure proper operation and to clear the hose of any obstructions (if hose is obstructed – refer to Troubleshooting section of this manual).
  - f. Close the nitrogen pressure source and slowly relieve remaining pressure by fully operating the nozzle lever.
9. Remove the agent cylinder cap and examine it closely for any signs of damage, cracks or thread wear. Clean the agent cylinder fill cap threads and thread vent port on the cap with a stiff bristle nylon brush. Remove the fill cap gasket and check for wear, cracks or tears – replace if necessary. Lightly lubricate the gasket with Visilox and reinstall.
  10. Examine the dry powder agent for proper type and condition. Replace chemical that is contaminated, caked or other than the type indicated on the nameplate (label). Do not trust the height of the chemical in the cylinder when determining agent fill. Dry powder settles and the only true indication of agent fill is to weigh the extinguisher and compare with the weight indicated on the nameplate (label).
  11. Place the service kit Vent Spacer on top of the agent cylinder fill opening collar. Check again to see that the fill cap thread vent is clean and that the agent fill cap gasket is in place. Install the agent fill cap securely over the vent spacer. Record service data on the extinguisher inspection tag.

**CAUTION: (STEP 12) The agent cylinder cap threads must be clear and the cap securely installed onto the vent spacer and agent cylinder to allow pressure to slowly vent after performing the siphon tube clearing and gas tube integrity checks.**

12. To perform a siphon tube clearing and gas tube integrity check:
  - a. Remove the service kit Agent Hose Adapter from the discharge hose assembly and install it securely onto the agent cylinder siphon tube outlet.
  - b. Using a regulated argon pressure source set to the extinguisher operating pressure (110 psi), slowly and briefly pressurize the agent cylinder (**the siphon tube should be clear within a couple of seconds and the agent cylinder pressure slowly vent from the fill cap thread vent**). Pressure and/or dry chemical agent leaks from the gas tube inlet port (where the hose connects) will indicate a defective gas tube and will require that the agent cylinder be emptied and the gas tube replaced.
  - c. Close the argon pressure source and allow all pressure to slowly vent from the thread vent port on the fill cap.
  - d. AFTER ALL PRESSURE HAS BEEN RELIEVED, **SLOWLY** OPEN THE FILL CAP AND **REMOVE THE TEST KIT VENT SPACER.**
  - e. Re-examine the agent to determine if any obstructions were cleared from the siphon tube and have risen to the surface.
  - f. Clean the fill cap and agent cylinder thread surfaces. Securely install the fill cap gasket and fill cap.

**NOTE: THIS STEP (R-d.) IS FOR REGULATED EXTINGUISHERS ONLY**

R-d. Disconnect the service kit quick connector adapter from the low pressure port of the regulator and reinstall the regulator securely to the agent cylinder.



13. Disconnect the high pressure hose from the argon cylinder valve. Securely install the service kit Argon/Nitrogen Cylinder Pressure Check Gauge Assembly to the nitrogen cylinder valve outlet and verify the indicated cylinder gauge pressure. Argon pressure should conform to the temperature correction chart provided in the Troubleshooting section of this manual. Close the nitrogen cylinder valve and disconnect the Pressure Check Gauge Assembly.

**WARNING: IF THE NITROGEN CYLINDER VALVE HAS A "T" HANDLE QUICK OPENING OR A HANDWHEEL QUICK OPENING TRIP RELEASE, THE SAFETY VENT PLUG SHIPPED WITH THE EXTINGUISHER, OR THE TEST KIT SAFETY VENT PLUG MUST BE INSTALLED TO PROTECT SERVICE PERSONNEL FROM A HIGH VELOCITY DISCHARGE IN CASE THE LEVER IS ACCIDENTALLY OPENED.**

14. Install a new Amerex Moisture Seal per instructions in the package. Securely connect the discharge hose to the extinguisher. **When assembling the hose to the agent cylinder or nozzle to the hose, tighten the coupling ¼ turn after contacting the hose gasket.**
15. Coil the hose on to the extinguisher hose rack using the Reverse Loop Procedure (see instructions in this manual). Install shut-off nozzle (and/or extension wand) with the lever in the Closed (forward) position into the nozzle mount.
16. Remove the safety vent plug from the argon cylinder. Reconnect the high pressure hose securely to the nitrogen cylinder valve. Wipe the extinguisher clean. Record service data on the inspection tag according to NFPA-10 requirements and attach to extinguisher. Return extinguisher to its proper location.

## RECHARGE

**NFPA 10 – Recharging is the replacement of the extinguishing agent and also includes the expellant for this type of extinguisher.**

### RECHARGING PROCEDURE

**WARNING: BEFORE ATTEMPTING TO RECHARGE, BE SURE THIS EXTINGUISHER IS COMPLETELY DEPRESSURIZED. THERE IS A CHECK VALVE IN THE SYSTEM WHICH PREVENTS ARGON PRESSURE FROM ESCAPING FROM THE AGENT CYLINDER WHEN THE ARGON HOSE IS DISCONNECTED. THE AGENT CYLINDER MAY BE PRESSURIZED EVEN THOUGH NO PRESSURE ESCAPES FROM THE CYLINDER ARGON CONNECTION.**

**NOTE:** Proper procedure for recharging any dry chemical extinguisher includes the use of a “closed recovery system (NFPA-10). The Getz Model SV1 400 VACU-FILL SYSTEM is ideal for this application – it provides for the recovery of the remaining agent by direct discharge into the system, trapping the “fines” while allowing the nitrogen to escape and provides a more accurate fill of the extinguisher.

**IF A “CLOSED RECOVERY SYSTEM” IS NOT AVAILABLE PROCEED AS FOLLOWS:**

1. To depressurize:
  - a. Close the argon cylinder valve.

- b. Carefully tip extinguisher over until it rests on both wheels and handle. (In this position much of the agent will remain in the cylinder).
  - c. Open nozzle valve slowly to clear hose of any remaining pressure and chemical (be prepared for a recoil and discharge of agent).
  - d. **Insure that all pressure has escaped before further disassembly.**
  - e. Stand extinguisher upright after complete depressurization.
2. Complete items 1-6 of Maintenance Procedures. Carefully remove the fill cap. Detach discharge hose from the agent cylinder and the nozzle assembly from the hose. Blow out any chemical remaining in the hose. While performing this procedure, all parts and seals should be cleaned, inspected and replaced where necessary.
3. Remove shutoff nozzle assembly from discharge hose and clean thoroughly. Check to make sure that the valve is closed when the lever is in the forward position (toward the nozzle tip).
4. Detach hose from nitrogen cylinder, install the shipping cap, unscrew the wing nuts and remove the nitrogen cylinder from the extinguisher.
5. Remove the 50 ft. discharge hose from the storage rack and disconnect the hose from the agent cylinder fitting. Blow out any dry chemical agent remaining in the hose. clean hose – remove and discard the clear hose gasket from the female coupling.
6. Remove remainder of ruptured moisture seal from the agent cylinder fitting. Replace with new Moisture Seal Assembly. **Carefully follow the installation instructions contained in the Moisture Seal Assembly package, including the installation of a new clear hose gasket in the female hose coupling.**
7. Remove the agent cylinder fill cap and gasket. Clean fill cap threads and vent port, lubricate the cap gasket and set parts aside. Check the condition and type of any remaining chemical (replace any dry chemical that is contaminated or caked). Fill extinguisher with the type and amount of dry chemical shown on the extinguisher label – verify gross weight. Clean agent cylinder collar threads. Install the fill cap and tighten securely.

**WARNING: DO NOT OVERFILL THE EXTINGUISHER. THIS COULD CAUSE A MALFUNCTION. DO NOT MIX TYPES OF AGENTS – THIS CAN CAUSE A DANGEROUS PRESSURE BUILD UP AND REDUCE EXTINGUISHER EFFECTIVENESS.**

8. Install the proper nitrogen cylinder (pressurized to 2015 psi), remove the shipping cap, place on the extinguisher and attach the nitrogen hose. **Nitrogen cylinders with “T” handle quick opening valve:** Remove small temporary ring (safety) pin and install large ring pin. Install a lockwire seal (tamper indicator). **Nitrogen cylinders with handwheel or lever actuated quick opening valve:** Leadwire seal must be installed
9. Reattach the discharge hose to the extinguisher (tighten hand tight plus a ¼ turn). Properly coil the hose onto the storage rack (see page 11). Reattach the shutoff nozzle firmly to the hose and store it in the mount with the shutoff lever in the **closed** (forward) position.
10. Record the service date on the inspection tag and place the extinguisher in its proper location.

## TROUBLESHOOTING GUIDE

**WARNING: BEFORE ATTEMPTING TO CORRECT ANY LEAKAGE PROBLEM, BE SURE THAT THE AGENT CYLINDER IS COMPLETELY DEPRESSURIZED.** Always use caution when opening the shutoff nozzle or any other connection as a leaking nitrogen cylinder valve seat may have pressurized the agent container refer to the recharge procedure for proper method of depressurization.

|    | PROBLEM  | CORRECTIVE ACTION   |
|----|--|---|
| 1. | Nitrogen cylinder gauge reads low or high  | Temperature may have affected the pressure reading<br>Temperature (F)    35°    70°    120°<br>Temperature (C)    2°    21°    49°<br>Recommended Pressure<br>psig                    1880    2015    2200<br>mPa                    13.0    13.9    15.2<br>Minimum Pressure<br>psig                    1590    1700    1900<br>mPa                    11.0    11.7    13.1<br><br>NO CORRECTIVE ACTION IS REQUIRED IF THE PRESSURE IS WITHIN PARAMETERS STATED ABOVE. |
| 2. | Nitrogen pressure is too low. Valve is closed. Tamper seal is intact. There is pressure in the agent and nitrogen cylinders. | Valve seat has leaked and has pressurized the agent cylinder. Follow Recharge Procedure for restoring the extinguisher to service.  |
| 3. | Nitrogen pressure is too low. Valve is closed. Tamper seal is intact. No pressure observed in the agent cylinder.            | Leakage in the nitrogen valve at other than the valve seal. Replace with a properly charged nitrogen cylinder.  |
| 4. | Shutoff nozzle does not move freely.   | Disassemble, clean and lubricate.   |
| 5. | Unable to remove the agent cylinder cap.   | Agent cylinder may be pressurized. Make no further attempt to remove the cap until this is checked. See the Recharge Procedure for proper depressurization method.  |
| 6. | Nitrogen hose cut, cracked or abraded.   | Replace hose assembly.  |
| 7. | Chemical agent and pressure leaking from the safety disc assembly. (Models 450, 451, 452)                                    | Inspect safety outlet for tightness or damage. Tighten if necessary.<br><br>NOTE: Only tighten the large hex nut of the assembly. The small round nut containing the holes is factory set to a specific torque value. Do not attempt to adjust. If damaged or ruptured, replace complete Amerex Safety Disc Assembly.   |



**1**

Connect hose coupling to outlet on the extinguisher. Lay hose straight on ground to its full 25 ft. length. Start first regular loop counter-clockwise by placing between side brackets and over the top bracket.



**2**

The second loop is a REVERSE loop. Notice that the hose passes behind the loop on this reverse loop. **If instructions are followed, the hose will uncoil without kinks.**



**3**

The next loop is a regular "hose in front" loop. Succeeding loops are alternated: reverse, front, reverse, etc. for six full loops.



**4**

Adjust the loops so that the nozzle or extension wand fits into the nozzle mount. Loops should be approximately the same size.

## Guide to Proper Installation of Hose on Wheeled or Stationary Fire Extinguishers



## PARTS LIST for 125/150 lb. Wheeled & Stationary Dry Chemical Extinguishers 110 Cu. Ft. Nitrogen Cylinder

### WHEELED MODELS

|     |                              |     |                              |
|-----|------------------------------|-----|------------------------------|
| 467 | 125 LB. ABC, 16" WHEELS      | 470 | 125 LB. ABC, 36" WHEELS      |
| 468 | 150 LB. REGULAR, 16" WHEELS  | 471 | 150 LB. REGULAR, 36" WHEELS  |
| 468 | 125 LB. PURPLE K, 16" WHEELS | 472 | 125 LB. PURPLE K, 36" WHEELS |

### STATIONARY MODELS

|     |                  |
|-----|------------------|
| 485 | 125 LB. ABC      |
| 486 | 150 LB. REGULAR  |
| 487 | 125 LB. PURPLE K |

| Item No.            | Part No.       | Description  | Std. Pkg. |
|---------------------|----------------|--|-----------|
| 1                   | 06993          | Cap (Chrome Plated Brass), Agent Cylinder                        | 1         |
| 1A                  | 12576          | Cap (Chrome Plated Brass), Agent Cylinder w/Pressure Indicator   | 1         |
| 2                   | 02272          | Gasket, Cap  | 1         |
| 3                   | 13958          | Bumper, Rubber   | 12        |
| 4                   | 02235          | Nitrogen Pressure Regulator                                      | 1         |
| 5A                  | 12467          | Nitrogen Valve with Gauge ("T" Handle Quick Release)             | 1         |
| 5B                  | 06373          | Valve Lever ("T" Handle-Complete)                                | 1         |
| 5C                  | 10213          | Gauge - 3000 psi   | 1         |
| 5D                  | 09897          | Valve Stem Assembly  | 6         |
| 5E                  | 00501          | Spring   | 6         |
| 6                   | 04128          | Nitrogen Cylinder (110 cu.ft.)-Charged with Cap, Valve & Gauge   | 1         |
| 7                   | 02234          | Nitrogen Hose Assembly   | 1         |
| 8                   | 11024          | Retaining Strap w/Hose Hanger                                    | 1         |
| 9                   | 11021          | Retaining Strap (Bottom) - Nitrogen Cylinder                     | 1         |
| 10                  | 16483          | Bolt, Washer & Wing Nut  | 1         |
| 11                  | 07485<br>07484 | Pictogram-467,470, 485<br>Pictogram-468,469,471,472,486,487      | 1         |
| 12                  | 07025          | Wheel Asy - 36" x 2 1/2" w/rubber tread                          | 1         |
|                     | 07389          | Hub Cap w/hardware - 36" Wheels                                  | 1         |
| 13                  | 07751          | Wheel Asy - 16" with Hub Cap, Washer & Retaining Pin (Semi-Pneu) | 1         |
| 14                  | 04945          | Hub Cap - 16" Wheels   | 1         |
| 15                  | 07411          | Moisture Seal  | 1         |
| 16                  | 03877          | Gasket, Hose/Nozzle  | 6         |
| 17                  | 06279          | Ball Valve Assembly  | 1         |
| 18                  | 06032          | Nozzle Tip (.265)  | 1         |
| 19                  | 03501          | Hose Assembly, 50'   | 1         |
| 20                  | 07574          | Nozzle Assembly (Ball Valve & Tip)                               | 1         |
| 21                  | 04892          | Hydrotest Adapter (Nitrogen Cylinder)                            | 1         |
| 22                  | 09857          | Fill Adapter   | 1         |
|                     | 05723          | Hydrotest Adapter (Hose)   | 1         |
| *                   | 06247          | Visilox Lubricant (5 oz. tube)                                   | 1         |
| * PART NOT PICTURED |                |  |           |

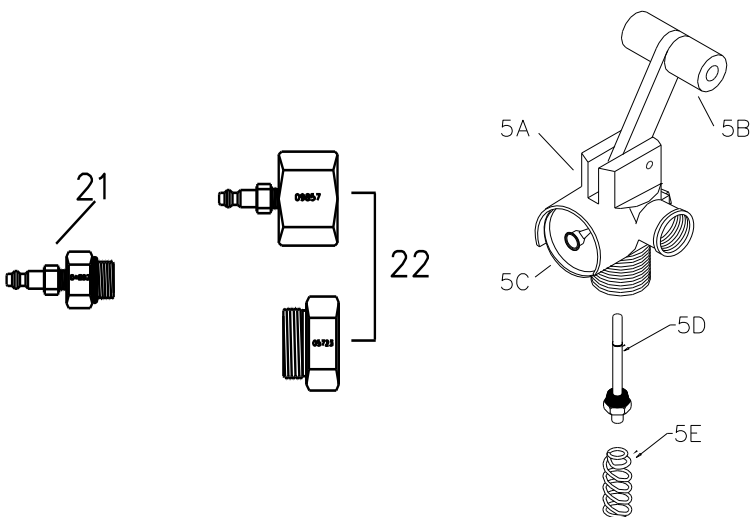
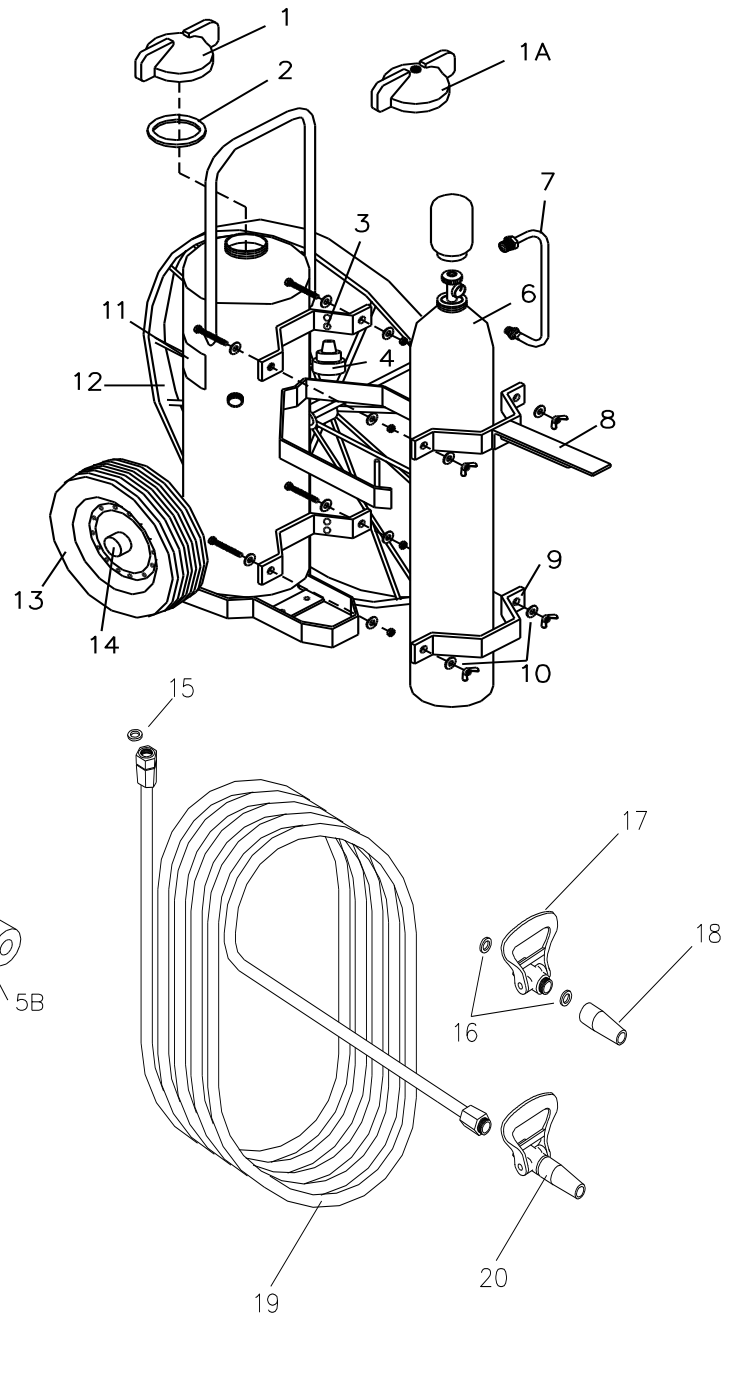

# PARTS LIST for 125/150 lb. Wheeled & Stationary Dry Chemical Extinguishers 23 Cu. Ft. Nitrogen Cylinder



### WHEELED MODELS

- 450 125 LB. ABC
- 451 150 LB. REGULAR
- 452 125 LB. PURPLE K

### STATIONARY MODELS

- 481 125 LB. ABC
- 482 150 LB. REGULAR
- 483 125 LB. PURPLE K

| Item No.                 | Part No.       | Description  | Std. Pkg. |
|--------------------------|----------------|--|-----------|
| 1                        | 06993          | Cap (Chrome Plated Brass), Agent Cylinder                        | 1         |
| 1A                       | 12576          | Cap (Chrome Plated Brass), Agent Cylinder w/Pressure Indicator   | 1         |
| 2                        | 02272          | Gasket, Cap  | 1         |
| 3                        | 03787          | Safety Disc Assembly   | 1         |
| 4                        | 03818          | Nitrogen Hose Assembly   | 1         |
| 5                        | 01990          | Rubber Bumper  | 12        |
| 6A                       | 12467          | Nitrogen Valve with Gauge ("T" Handle Quick Release)             | 1         |
| 6B                       | 06373          | Valve Lever ("T" Handle-Complete)                                | 1         |
| 6C                       | 10213          | Gauge – 3000 psi   | 1         |
| 6D                       | 09897          | Valve Stem Assembly  | 6         |
| 6E                       | 00501          | Spring   | 6         |
| 7                        | 03817          | Nitrogen Cylinder (23 cu.ft.)-Charged with Cap, Valve & Gauge    | 1         |
| 8                        | 04072          | Saddle Clamp WUS   | 1         |
| 9                        | 16483          | Bolt, Washer & Wing Nut  | 1         |
| 10                       | 07485<br>07484 | Pictogram-450<br>Pictogram-451, 452                              | 1         |
| 11                       | 07751          | Wheel Asy – 16" with Hub Cap, Washer & Retaining Pin (Semi-Pneu) | 1         |
| 12                       | 04945          | Hub Cap – 16" Wheels   | 1         |
| 13                       | 07411          | Moisture Seal  | 1         |
| 14                       | 03877          | Gasket, Hose/Nozzle  | 6         |
| 15                       | 06279          | Ball Valve Assembly  | 1         |
| 16                       | 06032          | Nozzle Tip (.312)  | 1         |
| 17                       | 03501          | Hose Assembly, 50'   | 1         |
| 18                       | 07574          | Nozzle Assembly (Ball Valve & Tip)                               | 1         |
| 19                       | 04892          | Hydrotest Adapter (Nitrogen Cylinder)                            | 1         |
| 20                       | 09857<br>05723 | Fill Adapter<br>Hydrotest Adapter (Hose)                         | 1<br>1    |
| *                        | 06247          | Visilox Lubricant (5 oz. tube)                                   | 1         |
| <b>PART NOT PICTURED</b> |                |  |           |

