



Safety Recall: Driver's Airbag Inflator Can Be Over-Pressurized

(Supersedes 08-093, dated January 16, 2009, to revise the information marked by the black bars)

REVISION SUMMARY

Under VEHICLES AFFECTED, the VIN ranges were expanded, and the total affected vehicles were increased to about 7,000.

BACKGROUND

A manufacturing error can produce over-pressurization of the driver's (front) airbag inflator during airbag deployment. If an affected airbag deploys, the increased internal pressure may cause the inflator casing to rupture. Metal fragments could pass through the airbag cushion material, possibly causing an injury or fatality to vehicle occupants.

VEHICLES AFFECTED

2001 Accord 2-Door:

From VIN 1HGCG3...1A003879 thru
1HGCG3...1A017292

From VIN 1HGCG2...1A006409 thru
1HGCG2...1A023548

2001 Accord 4-Door:

From VIN 1HGCF8...1A023478 thru
1HGCF8...1A085889

From VIN 1HGCG1...1A017330 thru
1HGCG1...1A060627

From VIN 1HGCG5...1A020393 thru
1HGCG5...1A097199

From VIN 1HGCG6...1A021403 thru
1HGCG6...1A100516

VIN 3HGCG6...1G701363

2001 Civic 2-Door:

From VIN 1HGEM2...1L003100 thru
1HGEM2...1L064024

2001 Civic 4-Door:

From VIN 1HGES1...1L031746 thru
1HGES1...1L047493

From VIN 1HGES2...1L031830 thru
1HGES2...1L046883

From VIN 2HGES1...1H514067 thru
2HGES1...1H569051

From VIN 2HGES2...1H517602 thru
2HGES2...1H565403

VIN 1HGEN2...1L000073

Within all the affected VIN ranges, there are only about 7,000 affected vehicles. To verify vehicle eligibility, you **must** check at least one of these items:

- The customer has a notification letter.
- The vehicle is shown as eligible on a VIN status inquiry.

In addition, check for a punch mark *below* the third character of the engine compartment VIN. A punch mark in that location means this campaign has already been completed.

Some vehicles affected by this campaign may be in your used vehicle inventory. As a matter of federal law, these vehicles must be repaired before they are sold.

Should a dealership sell an unrepaired vehicle that subsequently causes an injury or damage because of the recalled item, the dealership will be solely responsible to the damaged party, and will be required to defend and indemnify American Honda for any resulting claims. To see if a vehicle is affected by this campaign, do a VIN status inquiry before selling it.

CUSTOMER NOTIFICATION

Owners of affected vehicles have or will receive a notification of this campaign. An example of the customer notification is at the end of this service bulletin.

CORRECTIVE ACTION

Install a driver's airbag inflator kit, then return the original, **undeployed** inflator to its supplier, **ideally within 48 hours of the repair**.

PARTS INFORMATION

Driver's Airbag Inflator Kit:

P/N 04770-S84-308, H/C 9185737

Includes inflator with wire harness, locknuts (4), felt tape, felt washers (4), Torx bolts (2), and shipping instructions.

NOTE:

- The felt tape and the felt washers are used only on Accords.
- The inflator kit box must be used to return the old inflator to its supplier. Be careful not to damage the inflator kit box.

WARRANTY CLAIM INFORMATION

Operation Number: 7521F4

Flat Rate Time: 0.5 hour

Failed Part: P/N 06770-S84-A11ZA
H/C 6556476

Defect Code: 5SZ00

Symptom Code: Q9600

Template ID: 08-093A

Skill Level: Repair Technician

REPAIR PROCEDURE – ACCORD ONLY

NOTE: Be careful not to damage any parts when replacing the inflator, and **follow the procedure exactly.**

1. Remove the driver's airbag:
 - Refer to page 23-278 of the *1998–2002 Accord Service Manual*, or
 - Online, enter keywords **DRIVER AIR**, and select **Driver's Airbag Replacement** from the list.
2. Place the airbag, face down, on a clean shop towel.

3. Remove the four horn plate mounting bolts, the mounting bolt felt washers, and the horn plate. The felt washers will not be reused.

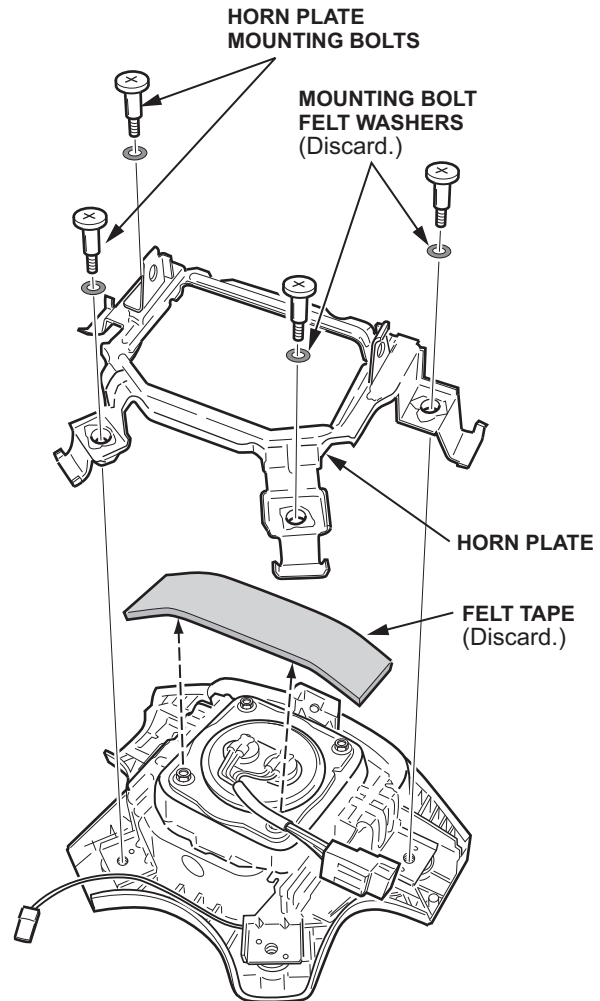

4. Remove and discard the felt tape covering the lower two inflator locknuts.

- Using needle-nose Vise Grips, remove the four locknuts from the inflator. The locknuts will not be reused.

NOTE: Do not remove the inflator from the airbag until you complete step 6.

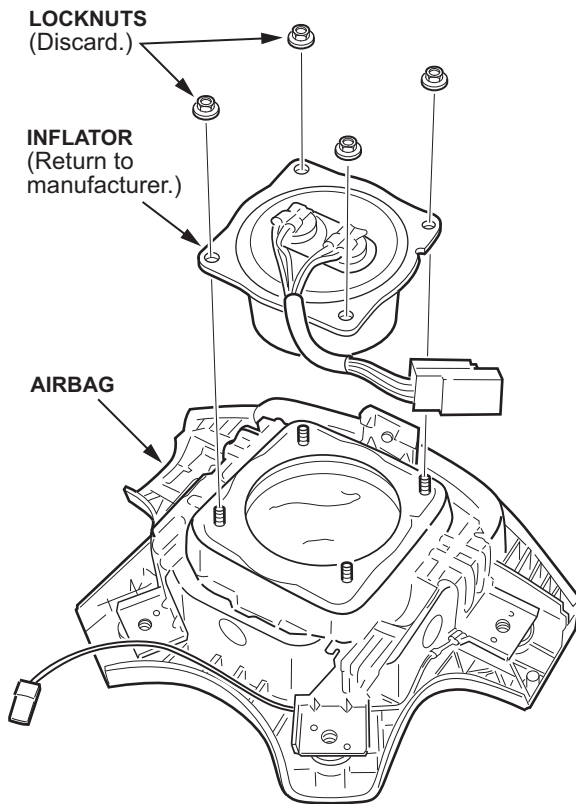

- Use shop air to clean any debris that may be on the inflator, then remove the inflator from the airbag.

NOTE:

- Do not allow any debris to enter the inflator opening in the airbag.
- Do not deploy the inflator.** The inflator must be returned to its supplier in the box the new inflator came in (see INFLATOR PACKING/ SHIPPING INSTRUCTIONS).

- Turn over the airbag (inflator side down), and shake it to remove any debris from the inflator opening.
- Install the new inflator in the airbag with new locknuts. Torque the locknuts to **3.9 N·m (2.8 lb-ft, 34 lb-in)**.
- Cover the lower two inflator locknuts with new felt tape.
- Reinstall the horn plate with new felt washers on its mounting bolts. Torque the mounting bolts to **3.4 N·m (2.5 lb-ft, 30 lb-in)**, then make sure the horn plate moves freely.

- Reinstall the driver's airbag using new Torx bolts:
 - Refer to page 23-279 of the service manual, or
 - Online, enter keywords **DRIVER AIR**, and select **Driver's Airbag Replacement** from the list.
- Center-punch a completion mark below the third character of the engine compartment VIN:

1HGCXXXXXXXXXXXXX

Center-punch here.

REPAIR PROCEDURE – CIVIC ONLY

NOTE: Be careful not to damage any parts when replacing the inflator, and **follow the procedure exactly**.

- Remove the driver's airbag:
 - Refer to page 23-137 of the *2001–2005 Civic Service Manual*, or
 - Online, enter keywords **DRIVER AIR**, and select **Driver's Airbag Replacement** from the list.
- Place the airbag, face down, on a clean shop towel.
- Using needle-nose Vise Grips, remove the four locknuts from the inflator. The locknuts will not be reused.

NOTE: Do not remove the inflator from the airbag until you complete step 4.

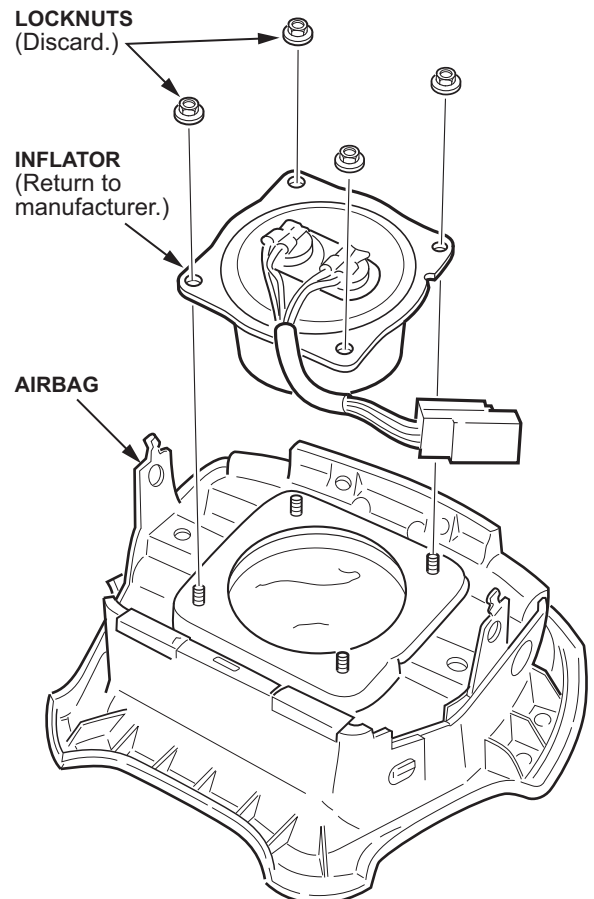

4. Use shop air to clean any debris that may be on the inflator, then remove the inflator from the airbag.

NOTE:

- Do not allow any foreign objects to enter the inflator opening in the airbag.
 - **Do not deploy the inflator.** The inflator must be returned to its supplier in the box the new inflator came in (see INFLATOR PACKING/ SHIPPING INSTRUCTIONS).
5. Turn over the airbag (inflator side down), and shake it to remove any debris from the inflator opening.
 6. Install the new inflator in the airbag with new locknuts. Torque the locknuts to **3.9 N·m (2.8 lb-ft, 34 lb-in)**.
 7. Reinstall the driver's airbag using new Torx bolts:
 - Refer to page 23-138 of the service manual, or
 - Online, enter keywords **DRIVER AIR**, and select **Driver's Airbag Replacement** from the list.
 8. Center-punch a completion mark below the third character of the engine compartment VIN:

1HGXXXXXXXXXXXX

Center-punch here.

INFLATOR PACKING/ SHIPPING INSTRUCTIONS

NOTE:

- **Do not deploy the original inflator. Claims for deployed inflators will be charged back to your dealership.**
 - There is a 48-hour return shipment objective for the inflator.
 - The following instructions are also included in the return shipping box (the box that the new inflator came in).
1. Carefully insert the original inflator into the round opening in the return shipping box (the box that the new inflator came in).
 2. Close the top flap on the box, then double-tape the box closed with 2-inch clear packing tape on the entire front seam and the side seams. Press down on the tape for good adhesion.
 3. Fill in this information on the FedEx airbill:
 - In the **From** section, add your name, address, and telephone number.
 - In the **Your Internal Billing Reference** section, add your 6-digit dealer number and the VIN.
 - In the **Does this shipment contain dangerous goods?** section, check the box next to **Yes per attached Shipper's Declaration**.
 - In the **Total Declared Value** section, do not add an amount.

4. Fill in this information on the SHIPPER'S DECLARATION FOR DANGEROUS GOODS form:

NOTE: If not already done, cross out the words **CARGO AIRCRAFT ONLY** in the **TRANSPORTATION DETAILS** box at the top left of the form. The shipper may reject your shipment if **CARGO AIRCRAFT ONLY** is not crossed out.

- In the **Shipper** section, add your name and address.
 - In the **Air Waybill No.** section, add the 12-digit tracking number from the top of the airbill.
 - In the **Page of Pages** section, add 1 of 1.
 - In the lower right corner of the form, print your name and title, your city, state, and the shipment date. Then add your signature.
5. For your records, keep one copy of the shipper's declaration and the sender's copy of the airbill. Insert the completed shipper's declaration and the airbill into an adhesive FedEx envelope, then attach the envelope to the box, most likely on the bottom. Do not cover any of the hazard markings or labels on the box.
 6. Attach a **From** label (your dealership address) and a **To** label (TK Holdings, Inc., as listed on the airbill) to the outside of the box. Do not cover any of the hazard markings or labels on the box.
 7. Before shipment, make sure steps 1 thru 6 have been completed. Incomplete or missing information may cause the box to be returned to you.
- NOTE: You (the shipper) are responsible for proper packing and document completion before shipping this box. The DOT (U.S. Department of Transportation) can *and will* impose substantial fines and/or penalties on the shipper (you) if the packaging, labeling, and/or documentation is/are not properly prepared. The person signing the document must be trained, and the training records must be on file at your place of business. Retain all documents for at least 2 years.

Example of Customer Letter

Safety Recall: Driver's Airbag Inflator

Dear Honda Owner:

This notice is sent to you in accordance with the requirements of the National Traffic and Motor Vehicle Safety Act.

What is the reason for this notice?

Honda Motor Co., Ltd., has decided that a defect related to motor vehicle safety exists in certain 2001 model year Accord and Civic vehicles. In some vehicles, the driver's airbag inflator could produce excessive internal pressure. If an affected airbag deploys, the increased internal pressure may cause the inflator to rupture. Metal fragments could pass through the airbag cushion material, possibly causing an injury or fatality to vehicle occupants.

What should you do?

Call any authorized Honda dealer and make an appointment to have your vehicle repaired. The dealer will replace the driver's airbag inflator module. This work will be done *free of charge*. Please plan to leave your vehicle for half a day to allow the dealer flexibility in scheduling.

Who to contact if you experience problems.

If you are not satisfied with the service you receive from your Honda dealer, you may write to:

American Honda Motor Co., Inc.
Honda Automobile Customer Service
Mail Stop 500-2N-7A
1919 Torrance Blvd.
Torrance, CA 90501-2746

If you believe that American Honda or the dealer has failed or is unable to remedy the defect in your vehicle, without charge, within a reasonable period of time (60 days from the date you first contact the dealer for a repair appointment), you may submit a complaint to:

Administrator
National Highway Traffic Safety Administration
1200 New Jersey Ave., SE
Washington, DC 20590

You can also call the toll-free Safety Hotline at 888-327-4236 (TTY 800-424-9153), or go to <http://www.safercar.gov>.

What to do if you feel this notice is in error.

Our records show that you are the current owner of a 2001 Accord or Civic involved in this campaign. If this is not the case, or the name/address information is not correct, please fill out and return the enclosed, postage-paid Information Change Card. We will then update our records.

Lessor information.

Federal law requires that any vehicle lessor receiving this recall notice must forward a copy of this notice to the lessee within 10 days.

If you have questions.

If you have any questions about this notice, or need assistance with locating a Honda dealer, please call Honda Automobile Customer Service at 800-999-1009.

We apologize for any inconvenience this campaign may cause you.

Sincerely,

**American Honda Motor Co., Inc.
Honda Automobile Division**