

**COLDELITE®**

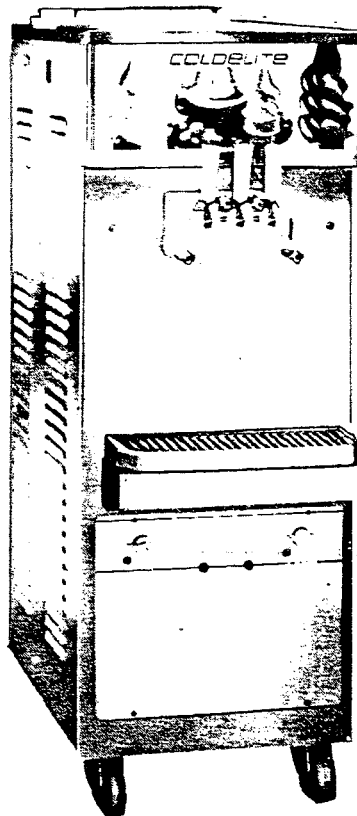

**Soft Serve Freezer**

DOUBLE FLAVOR, FLOOR MODEL UF-253G

**OPERATION and SERVICE  
MANUAL**

**COLDELITE CORPORATION OF AMERICA**

3760 INDUSTRIAL DR. • WINSTON-SALEM, N.C. 27105 • TEL. (919) 661-9893 • FAX (919) 661-9895



# I N D E X

	<u>Page</u>
Foreword	1
<u>PART I</u> <u>INSTALLATION</u>	2
A) Unwrating	2
B) Positioning the Machine	3
C) Machines with Water Cooled Condensers	3
Water Valve Adjustment	4
WARNING	4
D) Machines with Air Cooled Condensers	4
E) Electrical Connections	4
Electrical Requirements	4
Beater Rotation	5
IMPORTANT - WARNING INFORMATION	5
<u>PART-II</u> <u>EXPLANATION OF ELECTRICAL CONTROLS</u>	6
A) Control Panel	6
B) Other Controls	7
<u>PART III</u> <u>INITIAL CLEANING PROCEDURE</u>	8
Assembling the Freezer	8, 9, 9a
<u>PART IV</u> <u>SANITIZING THE FREEZER</u>	10, 10a
Routine, Periodic Cleaning Procedures	13
<u>PART V</u> <u>STARTING THE FREEZER</u>	11
<u>PART VI</u> <u>GENERAL INFORMATION</u>	
Gravity Feed Valve and How to Operate	12
How to Adjust the Gravity Feed Valve	12
<u>PART VII</u> <u>TECHNICAL DATA</u>	14
A) Refrigeration - Compressor, Beater Motor	14
Adjusting Product Temperature	14
How to Adjust Rear Micro Switch	15, 16
Cut-Out Amperage	14
WARNING	16
Hard-O-Matic Springs	16
Mix Tank Refrigeration	17
Energy Conservation Switch	17
a) How It Operates	
b) Calibration of Temperature in Cylinder	17
c) Calibration of Temperature in Hopper	17

## I N D E X

	<u>Page</u>
2) <u>BEATER ACTIVATING SWITCH</u> and How It Operates	18
How to Adjust the Front Micro Switch	18
C) <u>MAINTENANCE</u>	19
WARNING	19
<u>TROUBLE SHOOTING GUIDE</u>	20, 21, 22, 23
Appendix - Figures 1 - 9	
Wiring Diagrams	
Legend of Schematic Symbols	
Parts - Description and Code Numbers	



## F O R E W O R D

Thank you for selecting COLDELITE to meet today's fast growing demands. Your COLDELITE freezer has been manufactured at the most modern freezer manufacturing plant in the U.S.A., our Lodi, New Jersey facility, utilizing the most advanced equipment and technology available in the industry. We, at Coldelite, take great pride and care in the manufacture of each and every freezer, using only the finest components available, to provide you with years of trouble-free operation.

Over twenty-five years of experience in the manufacturing of dispensing equipment have guided us in the preparation of this Operation and Service Manual. PLEASE READ IT CAREFULLY. Keep it for future reference and most of all, follow the instructions from the very time your machine is delivered.

On the following pages, you will find important information and procedures which describe the proper installation, sanitizing, operation and maintenance of your COLDELITE machine. We feel certain that your full compliance with these instructions will assure you of excellent performance, trouble-free operation and a profitable business for years to come.

## N O T I C E

Failure to closely follow set-up and maintenance procedures can void your warranty. Coldelite Corporation will not be responsible for any machine not properly maintained.

In the event this unit should malfunction, please contact your Coldelite distributor or an authorized service agency.

## W A R N I N G

EXTREME CARE MUST BE TAKEN WHEN REMOVING SIDE, REAR OR CONTROL BOX PANELS.

ALWAYS TURN THE SELECTOR SWITCH TO THE OFF POSITION. ALSO TURN OFF THE DISCONNECT SWITCH ON ELECTRICAL SUPPLY LINE BEFORE EXPOSING ANY ELECTRICAL CONNECTIONS AND/OR MOVING PARTS, SUCH AS BELTS, PULLEYS, FAN BLADES AND BEATER.

# I N S T A L L A T I O N

## PART I

### A - UNCRATING

Before starting this procedure, make sure the carton does not show evidence of having been dropped, tampered with or abused in such a way as to indicate that its contents may have been damaged in transit.

---

IMPORTANT - In the event the outside of the carton should give any indication of possible hidden damage, state this on the bill of lading before signing. Contact the carrier immediately and request an inspection of the damage. If this is not done, you are responsible and must pay for any repairs required.

---

1) Proceed with the uncrating, as follows:

a) If the unit arrives in a carton, it is held by plastic strapping. When you cut this strapping, do it with caution as it may spring out. Then remove the cover, and lift the carton straight up.

b) If the unit arrives in a crate, the crate is nailed around the bottom perimeter. Remove all nails. The crate has corner supports, three of which are riveted and the other one, stapled. By removing the staples, you will be able to slide the crate off the skid. The crate may also be lifted vertically, if there is sufficient head room.

c) Inspect the machine thoroughly for damage before removing the skid. If the machine is damaged, do not remove the skid. Contact the carrier immediately, file your claim, and save all the crating material.

2) Remove the two side drip chutes. Remove the screws holding the side panels. The panels may now be removed by simply sliding them upward slightly, then pulling outward at the bottom, allowing the panel to slide down. The machine is held to the skid by bolts and nuts on the left and right side. Remove these bolts and the skid.

Check inside the hopper for accessories and parts, which should be removed and unpacked.

## B - POSITIONING THE MACHINE

1) The freezer is now ready to be placed in its location. In selecting the location, consideration should be given to the following:

- a) If the unit is air cooled, allow at least 20 inches from the rear of the machine to the wall, so that there is a flow of air circulating around the unit.
- b) If the unit is water cooled, it should be located close to the water supply and a drain within six feet.
- c) The machine should also be close to the power supply, a plug, and receptacle or unfused disconnect and within six feet.
- d) Position the machine for easy accessibility for cleaning, servicing and maintenance.
- e) Protect the machine from the sun. For every 2°F over 68°F, the machine's performance will decrease by 1%.
- f) Once the machine is set in its position, it must be leveled as accurately as possible.
- g) Free the compressor by loosening the retaining bolts and removing the fastening blocks, if any. The compressor should float freely on its mounting grommet. Clearance between rubber grommet and retaining bolts should be approximately 1/16 of an inch.
- h) Place the machine in a conspicuous area to be readily seen by the public. This will increase the demand for ice cream.

## C - MACHINES EQUIPPED WITH WATER COOLED CONDENSERS

Machines equipped with water cooled condensers must be connected to a running water line with a pressure of at least 35 psi, and a flow equal to the estimated consumption per hour (see Water Valve Adjustment).

Connect fitting marked "Water In" to the cold water supply, preferably with a shut-off valve, and connect the fitting marked 'Water Out' to a drain.

All plumbing must meet local and state plumbing codes. In some cases the use of a high pressure flexible hose with a pressure rating of at least 120 psi may be used to facilitate moving the machine for cleaning, maintenance, etc.



## WATER VALVE ADJUSTMENT

The water valve is preset at the factory, but if an adjustment should be required, proceed as follows:

To maintain a head pressure of 240-250 psig while the compressor is running, attach a refrigeration high pressure gauge to the compressor's high side discharge port, and open the valve clockwise to increase the pressure or counter clockwise to decrease the pressure.

Estimated consumption is 80 gallons per hour. This figure will increase if the water temperature is over 68°F.

## W A R N I N G

Never expose water cooled machines to temperatures at or below 32°F without having drained the water from the condenser.

To drain, high pressure air should be blown through the water line from the water inlet while the compressor is running (so water valve is open). This operation should be performed by a refrigeration service man.

If this drainage is not done properly, serious damage can occur.

## D) MACHINES WITH AIR COOLED CONDENSERS

Maintain at least 20 inches from the rear of the machine to the wall.

The condenser should be cleaned once a month to avoid dust and litter from obstructing the flow of air which could affect the performance of the machine and possibly stop its operation.

## E) ELECTRICAL CONNECTIONS

Wiring should be made in accordance with the National Electrical Code and/or local electrical codes, rules and regulations.

### ELECTRICAL REQUIREMENTS - MODEL UF-253

<u>F.L.A</u>		<u>F.L.A</u>		<u>WIRE SIZE</u>
1 Ph. Air	48.0 Amps.	3 Ph. Air	31.2 Amps.	1 Ph. - #8
1 Ph. Water	45.4 "	3 Ph. Water	28.7 "	3 Ph. - #10

POWER SUPPLY must be adequate to meet requirements at all times. Voltage fluctuations, with the machine in operation should not exceed  $\pm 10\%$  of the normal or rated voltage.

ADEQUATE WIRING should be provided with regard to wire size or gauge. Unless otherwise required by the local Electrical Code, same wire gauge at the machine junction box should be used for

ADEQUATE WIRING should be provided with regard to wire size or gauge. Unless otherwise required by the local Electrical Code, same wire gauge at the machine junction box should be used for the direct power line. See chart on previous page. A separate circuit breaker with adequate fuse protection, should be employed.

An unfused disconnect switch or proper size plug-in, close to the freezer, is recommended.

#### BEATER ROTATION

After electrical connections are completed, check the rotation of the beater motor to see if it is in accordance with the arrow marked on the body of the fly wheel. The rotation of the beater should be clockwise. See Page 9b.

COLDELITE freezers are provided with protection on the beater motor. Should the line voltage drop or if there is a short circuit, the overload protector will automatically disconnect the starter and the machine will stop immediately so that no permanent damage can be caused to the motor. To start the freezer again, push the RESET button located on the front lower portion of the control panel. The heater or overload must cool down for several minutes before the RESET button will operate.

The compressor is also internally protected. If the Klixon protector trips due to an overload, the compressor will re-activate after the Klixon automatically resets.

#### I M P O R T A N T

IN ALL INSTALLATIONS, BOTH SINGLE AND THREE PHASE, THE MACHINE MUST BE PROPERLY GROUNDED. SINCE ALL ELECTRICAL COMPONENTS ARE CONNECTED BY MEANS OF FLEXIBLE CONDUIT, ADEQUATE GROUND CONTINUITY IS ASSURED BY RUNNING AND FASTENING A GROUND LINE TO THE MACHINE JUNCTION BOX.

#### W A R N I N G

BEFORE REMOVING THE COVER OF THE CONTROL BOX IN FRONT OF THE MACHINE, TURN THE SELECTOR SWITCH TO OFF POSITION AND DISCONNECT MAIN SWITCH IN THE CIRCUIT BREAKER BOX.

---

PART II

EXPLANATION OF ELECTRICAL CONTROLS

A) CONTROL PANEL - SELECTOR SWITCH (Figure 1 - Code #1720160)  
Also see Figure A, below.

OFF - Machine is off.

AUTO - This position is used for production and the dispensing of the ice cream. The consistency of the product is controlled by the Hard-O-Matic. The temperature of the mix in the hopper is controlled by the thermostat, TEV.

ENERGY CONSERVATION - The beaters do not run. The product in the freezing cylinders is held at the correct storage temperature by the thermostat, TEC. The temperature of the mix in the hoppers is controlled by the thermostat, TEV. The product should not be served when in this position.

BEATER - Only the beater motors run. Refrigeration circuits are cut off. This position is to be used during the cleaning, sanitizing, and start-up operation.

WHITE LIGHT - Figure 1, Code #1711210 - When light is on, it indicates that the control switch has been set on BEATER. The machine should never be left in this position for any period of time longer than is necessary for normal cleaning. This light serves as a reminder to prevent its overuse.

RESET BUTTON - Figure 1, Code #1720370 - Used for resetting the motor protectors of the beater motor in case of voltage failure, phase interruption or jamming of the beaters.

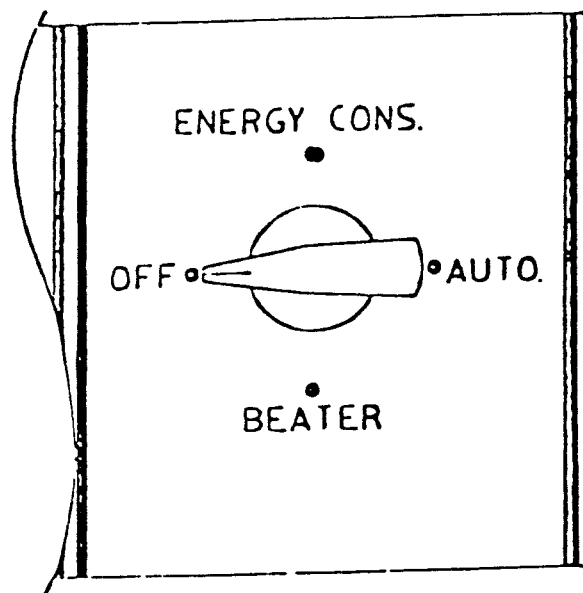

fig. A

## B) OTHER CONTROLS

### FRONT MICRO SWITCHES (Figure 4, Code #1720260)

Switches are simultaneously activated by opening any spigot thereby starting the beater motor and allowing the Hard-O-Matic to sense the consistency of the product.

REAR MICRO SWITCH (Figure 2, Code #1720260) operates in conjunction with the Hard-O-Matic to keep the product at the proper consistency. (For adjustment, See Part VII, Page 15.)

ENERGY CONSERVATION THERMOSTAT (TEC) holds the temperature of the product in the cylinders at a temperature no higher than 28°F when the machine is placed in the ENERGY CONSERVATION mode. (For adjustment, see PART VII.)

HOPPER THERMOSTAT (TEV) controls the temperature of the mix in the hopper. (For adjustment, see Part VII.)

FILL LIGHT (Figure 1, Code #1711150) indicates level of mix in the hopper has fallen low and more mix should be added. These lights are located to the left and right of the spigot head and are orange in color. The light is activated when mix tank is down to the last 1/2 gallon.

LEVEL SWITCH (Figure 9, Code #1664100) - The position of the float (Figure 9, Code #1664010) will close the switch when the level of the mix has fallen below preset level.

### PART III

### INITIAL CLEANING PROCEDURE

This machine is new and it must therefore be completely disassembled, washed, and sanitized before starting it. Proceed as follows:

- 1) Remove mix tank cover and items packed in the tank (spare parts, sanitizer, lubricant, gravity feed tube, etc.).
- 2) Now remove the remaining parts from the machine. Remove the four hand knobs holding the head in place. Then remove the head assembly itself. Pull the auger out of the cylinder. Make certain that the lip seal on the rear of the shaft is removed. It is advisable to use a dish pan to put the parts in so that no part is dropped or lost. This should be a plastic pan.
- 3) You now have all the parts for the freezer in the sink. Wash all these parts with a detergent and the brushes supplied with the machine. DO NOT USE HOT WATER ON ANY PLASTIC PARTS. Rinse all parts in warm water. Do not dry these parts but allow to air dry or assemble wet.

ASSEMBLY OF FREEZER - Reverse the above procedure. Install auger first, being sure that the lip seal is on the rear of the auger and has been lubricated on both sides with the sample lubricant supplied. All 'O' rings must be lubricated lightly with Petrogel or equivalent.

When reassembling the freezer, refer to the illustration, Figure I

CAUTION - It is very important to have the idler installed correctly. If not done properly, damage can be caused to the spigot head assembly. Assembly instructions should be carefully followed

When assembling the idler, first hold it so that the fins are in an upright position. Then insert it so that the thinner portion of the idler shaft fits into the grooved slot at the front of the beater/auger, Code #1640300, Figure C. The grooved slot must be facing up at all times. The front bar of the idler should be in a horizontal position. Push the idler back, inserting its shaft into the hole of the beater/auger shaft. If installed correctly, the idler, when turned, should rotate freely and will be automatically locked in place. If it does not rotate, it is installed incorrectly. Go through the above instructions again.

## ASSEMBLING THE FREEZER:

Reverse the preceding procedure. Install the augers/beaters first, making sure the lip seal is on the rear of the augers and has been lubricated on both sides.

WARNING - It is very important to have the idler installed correctly. If not done properly, damage can be caused to the spigot head assembly. Assembly instructions should be carefully followed. See Figure 8.

When assembling the idler, first hold it so that the fins are in an upright position. Then insert it so that the thinner portion of the idler shaft fits into the grooved slot at the front of the beater/auger (Item 21). The grooved slot must be facing up at all times. The front bar of the idler should be in a horizontal position. Push the idler back, inserting its shaft into the hole of the beater/auger shaft. If installed correctly, the idler, when turned, should rotate freely and will be automatically locked in place. If it does not rotate, it is installed incorrectly. Go through the above instructions again.

Finally, when properly installed, the front bar of the idler should be in a vertical position so that the bar will not interfere with the two pins located inside the spigot head, when the head is installed. (See drawings on following page.)

All 'O' rings and the gears in the pumps must be lubricated lightly with Petrogel or equivalent. Remember that you have a pressurized machine and there must be NO leak in the pressure system.

Insert the pump drive shaft through the hole at the back of the mix tank, rotate by hand until it engages properly with the drive shaft pulley. Hold complete pump assembly in a vertical position and slide over drive shaft. Rotate back and forth until the drive shaft clicks into place in the pump drive gear. Push assembly towards back of machine and turn counter-clockwise until the pump is horizontal and the pump locking hook is engaged with the tank lock pin.

Slip feeding tube assembly into hole at bottom of mix tank. Hold at right angle to length of tank, and tube assembly will easily drop into place.

When reassembling the freezer, use the diagrams that follow as a guide.

Finally, when properly installed, the front bar of the idler should be in a vertical position so that the bar will not interfere with the two pins located inside the spigot head, when the head is installed. (See drawings on following page.)

FIGURE B

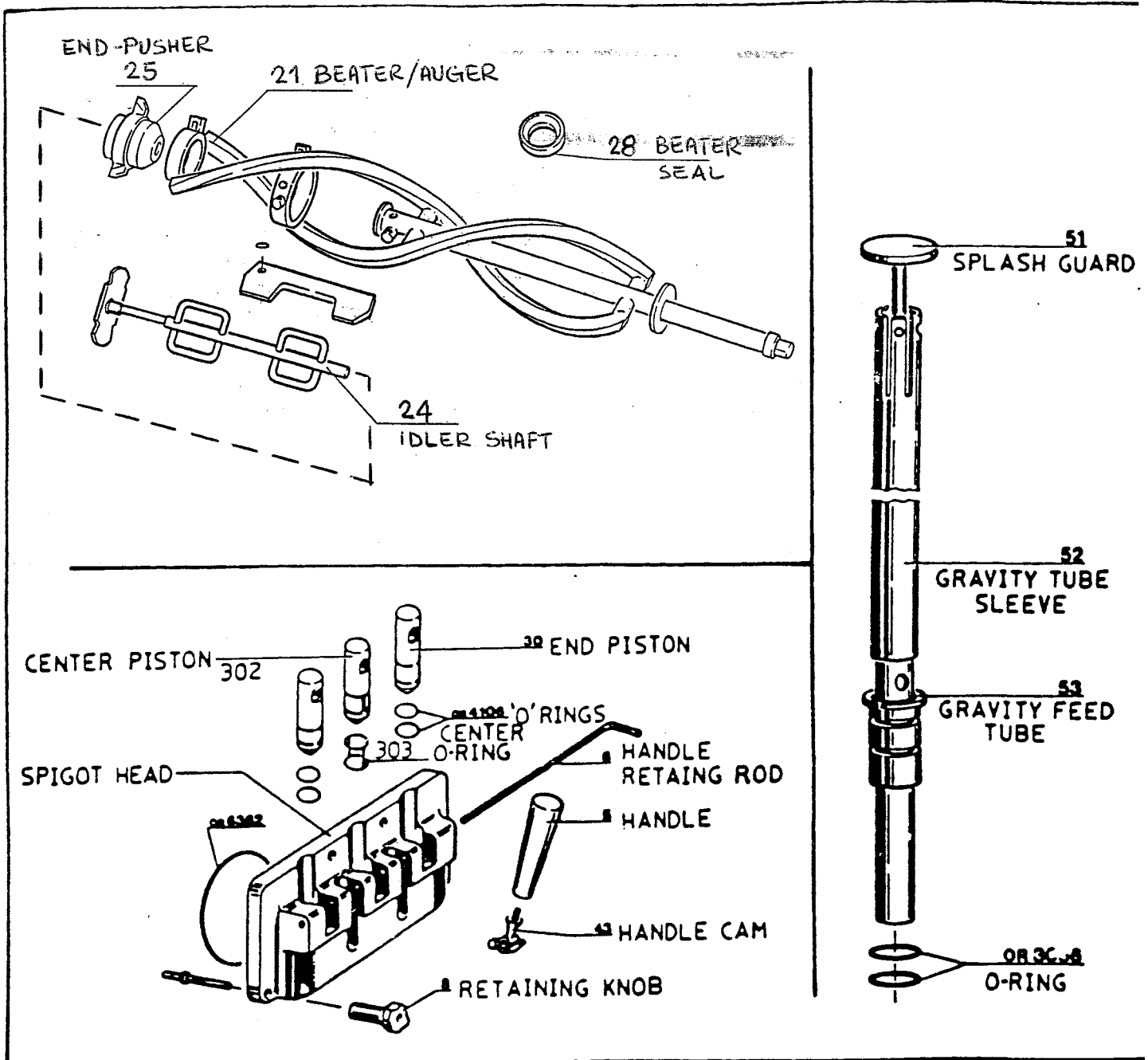

TWIST HEAD ASSEMBLY

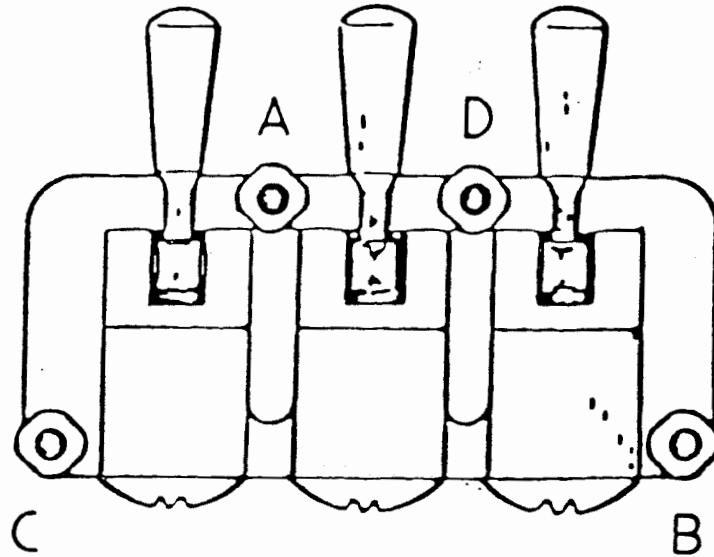

TIGHTEN KNOBS ACCORDING TO  
LETTER SEQUENCE

IMPORTANT

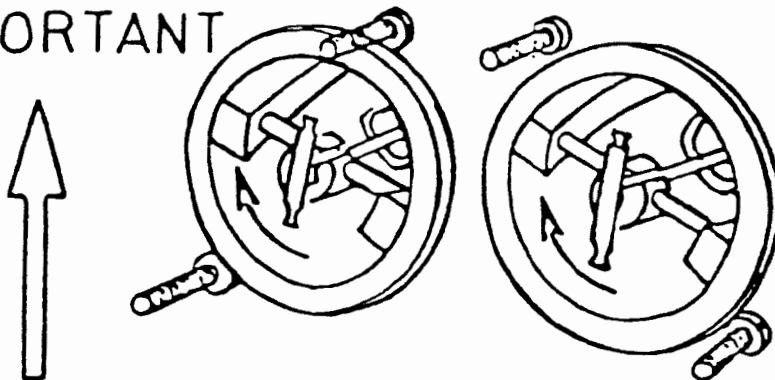

BEATER IDLER SHAFT MUST SPIN FREELY  
AND BE IN A VERTICAL POSITION, AS SHOWN,  
PRIOR TO INSTALLING SPIGOT HEAD.



## SANITIZING THE FREEZER

The freezer is now washed and reassembled. The next step is to sanitize the machine which is most important. This procedure will retard the growth of bacteria and insure excellent tests on your product when examined by the Sanitation and/or Department of Agriculture.

First, mix the sanitizer in a clean pail. Hot water first, to dissolve the powder, and then cold water. Instructions are on the sample sanitizer that is included with the machine. Usually two tablespoons to two gallons of water will give you a solution of 200 ppm chlorine, which is sufficient to kill the bacteria. Do not exceed the formula as it does not add to its effectiveness.

With the selector switch in the OFF position, pour one gallon of sanitizer into the mix tank. Lay the gravity feed tube in the mix tank so that it is covered with the sanitizing solution. Now turn the selector switch to BEATER for only a few seconds.

The sanitizer will now run freely into the cylinder. Simply place a bucket or drain attachment under the head and allow the sanitizer to run out. During this operation, the selector switch is in the OFF position.

We recommend that the auger/beater be turned as little as possible during the washing and sanitizing operations. In the last phase, you can turn the selector switch to BEATER for two or three seconds to help remove the last of the sanitizer.

For sanitary reasons, the plastic cover on top of the mix tank should be removed only for the time strictly necessary to make the desired adjustments.

## CLEANING AND SANITIZING INSTRUCTIONS

### NSF REGULATIONS

1. Drain machine of all mix and rinse with cool water.
2. Turn selector switch(s) to OFF position.
3. Remove and disassemble spigot head, gravity feed tube, and beater(s).
4. In a clean pail, mix one ounce of Nu-Foam Liquid Detergent (or equivalent) with three gallons of warm water (70 - 80°F). Clean and brush all surfaces in contact with product. Flush thoroughly with warm water.
5. Reassemble all parts and install on machine. See instructions in manual.
6. In a clean pail, mix two ounces of Stera-Sheen Green Label Sanitizer (or equivalent) with two gallons of warm water. This will make a 200 ppm concentration of chlorine sanitizing solution.
7. Fill hopper(s) and cylinder(s) with sanitizing solution.
8. Turn selector switch(s) to BEATER position for approximately 30 seconds. Make sure sanitizer solution is in contact with product contact surfaces for three to five minutes.
9. Drain machine thoroughly before refilling with product.

PART V

STARTING THE FREEZER

The model UF-253G is now sanitized and ready for production.

Start the machine as follows:

1) Insert the gravity feed tube in the mix tank. Pour at least one gallon of liquid mix into the mix tank. The maximum capacity of the hopper is two gallons. Never load mix above the top of the feeding tube. See diagram below.

Turn the selector switch to BEATER and allow the machine to run a few seconds. Place a pail or cup under the dispensing nozzle, open the dispensing plunger and let the mix push out any sanitizer left in the cylinder. When pure mix comes out of the head, close the spigot handle and allow the machine to continue to run with the switch in the BEATER position for one minute.

An alternate method of "pre-filling" the cylinders is to pour 3 pints of liquid mix into the freezing cylinders prior to installing the gravity feed tubes. Once filled with 3 pints of liquid, the gravity tubes should be installed, machine selector switch turned to the "auto" position, and hoppers filled to maximum level as shown below.

2) Now turn the selector switch to AUTO. This activates the torque control to sense that refrigeration is required. Then simply allow the machine to run until it goes off automatically.

3) You are now ready to draw a finished product. Pull the dispensing handle down slowly until the product comes out. The freezer is now in the normal operating position. Be sure to add mix when necessary, and simply dispense the product, as required.

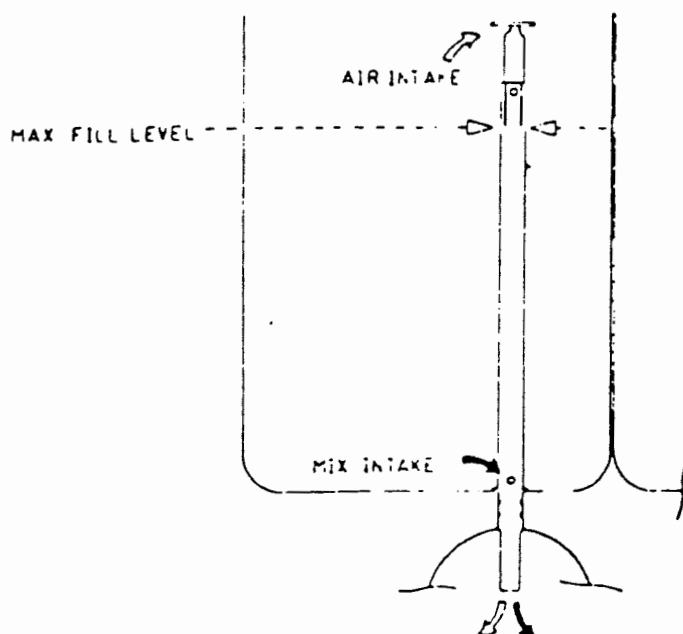

GRAVITY FEED VALVE, HOW TO OPERATE AND MAKE ADJUSTMENTS

In the mix tanks, supplied with the machine, you will find two gravity feed tubes. Each consists of two tubes, one sliding inside the other and a plunger/splash guard.

The inner tube blends the flow of air and mix into the freezing cylinder. Air enters through the top of the tube and the mix through a round hole at the base as illustrated below.

The outer tube is actually a valve. Rotating it from hole to hole on the outer tube varies the size of the hole and the amount of mix that flows into the freezing cylinder. The size of the air inlet, at the top of the tube, does not change so the amount of air that enters the freezing cylinder is constant.

You can vary the overrun by letting more or less mix enter the freezing cylinder by manually regulating the valve. You must align the mix inlet holes on both the inner and outer tubes or no mix will enter the cylinder. You can see this hole at the top of both tubes. (see diagram below).

The plunger/splash guard keeps the mix from splashing on the mix tank cover and serves as a device to eliminate potential clogging inside the tubes.

You may find it necessary to adjust the position of the outer tube in order to regulate the amount of mix entering the freezing cylinder after start-up. Actually, sales conditions will dictate the proper adjustment.

If more production is required, increase the opening by rotating the outer tube to a larger hole, and conversely, when business is slow, rotate to a smaller hole on the outer tube, reducing the opening. Naturally when the mix runs low in the mix tank, you will open the slot more and eventually take the feed tube out completely to use the last of mix in the mix tank.

Energy conservation: During long idle periods, it is recommended the outer sleeve of the gravity tube be rotated to the position which closes mix intake hole completely.

IMPORTANT: Remember to rotate the outer tube to the appropriate opening before switching to the "automatic" mode.

MINIMUM PRODUCTION

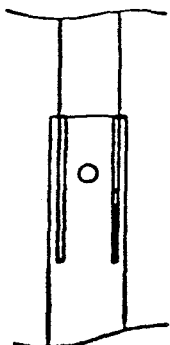

MODERATE PRODUCTION

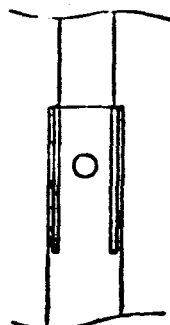

MAXIMUM PRODUCTION

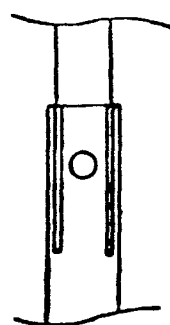

ENERGY CONSERVATION

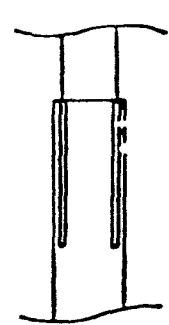

## ROUTINE, PERIODIC CLEANING PROCEDURE

Cleaning and sanitizing schedules are governed by your state or local regulatory agencies and must be followed accordingly. A well planned cleaning schedule will eliminate excessive waste of time and product within your organization.

On a designated day(s) of the week, run the mix in the mix tank as low as feasible.

Proceed to clean the machine, as follows:

1) Remove the gravity feed tube. Turn the Selector Switch to BEATER position and let the machine run for 4 to 5 minutes. This will soften the product in the cylinder and allow the remaining product to be removed easily.

2) Place a container or bucket under the spigot head. Slowly pull the handle down and remove remaining product from the cylinder.

3) When the product has stopped flowing, turn the Selector Switch to the OFF position. Close the spigot handle. (See Part III - Initial Cleaning Procedure.)

4) Fill hopper(s) and cylinder(s) with cold water and using a mild detergent (a non-foaming, dishwashing detergent is recommended) brush surface areas to remove all mix particles. Turn Selector Switch to BEATER position for one (1) minute. Turn Selector Switch to OFF position, drain water by pulling dispensing handle open. Repeat process until water is clear.

IMPORTANT - Operate unit in BEATER position only when cleaning. Do not operate unit for excessive periods in the BEATER position. One (1) minute intervals per rinse is recommended.

5) Drain water, remove the dispensing head and beater/augers.

6) Carefully disassemble all parts, i.e., 'O' rings, pistons, seals, etc. Refer to Initial Cleaning Procedure, Page 8. Use cleaning brushes provided to clean all surface areas.

7) Rinse parts in lukewarm water and submerge in a 200 ppm sanitizing solution for a minimum of 3 to 5 minutes. Place parts on a clean, sanitary counter and allow to air dry.

8) Assemble and lubricate all parts as illustrated in Operations Manual. Install parts in machine; refer to Assembly Procedure on Page 8.

9) Fill hopper(s) and cylinder(s) with 200 ppm sanitizing solution. Let stand for 3 to 5 minutes minimum.

10) Drain all sanitizing solution from machine and refill with fresh mix. Refer to Page 11 for proper starting procedure.

PART VII

TECHNICAL DATA

A REFRIGERATION

Compressor - Hermetic - 2 hp - R502

Actual Running Amps. (FLA) - 1 Phase - 7.0

Actual Running Amps. (FLA) - 3 Phase - 4.5

Suction Pressure - 20-22 psig

High Side Pressure - 240-250 psig

Cooling System - Air or Water

Refrigerant - R502 ONLY - Water Cooled - 2.3 lbs.

Air Cooled - 2.8 lbs.

B Beater Motor - 1.5 hp

H.O.M. Cut-Out Amperage

Single Phase - 8.4 Amps. - G.E. Motor

Three Phase - 4.8 Amps.

---

Single Phase - 5.0 Amps. Century Motor

Three Phase - 3.2 - 3.5 Amps.

---

Main Drive Belt - (3) - Code #3415540 - Single Phase }  
Code #3415550 - Three Phase } **Each**  
Pump Drive Belt - (1) - Code #1914120 } **Side**

---

1) ADJUSTING PRODUCT TEMPERATURE

Coldelite uses a Hard-O-Matic system (patented) which is referred to as HOM. This mechanical device controls the refrigeration system for the freezing cylinder by 'sensing' the consistency or hardness of the product inside the freezing cylinder. No thermostats are used in this system.

Basically, the HOM control consists of a clutch assembly (Fig. 2). The inclines of a disc, fastened to the fly wheel, are engaged to the inclines of another disc which in turn rotates the auger.

A set of springs, properly calibrated and radially located around the fly wheel, maintains the two discs engaged by exerting a certain pressure.

With the gradual hardening of the product inside the freezing cylinder, a certain resistance or drag will be exerted on the auger by the product itself.

The disc, rotating the auger, will also be affected by this drag and will start sliding on the inclines of the other disc, overcoming the pressure of the springs.

The gradual separation of the two discs, as a result of the sliding of the inclined surfaces of one disc against the other will move the complete drive assembly toward the rear of the machine.

By the time the product has reached the proper consistency or hardness, the drive assembly will have moved backwards just enough to open a normally closed micro switch fastened to the support on the rear frame of the machine.

The opening of this micro switch will de-energize the coil of the compressor contactor which will immediately stop the beater motor and compressor simultaneously. Thus the refrigeration system is controlled by the consistency of the product in the freezing cylinder and not by temperature controls.

When you pull the handle on the spigot head to draw a cone or portion, another micro switch is automatically closed, which bypasses the Hard-O-Matic micro switch and starts the beater motor only. This simultaneously pumps new product into the freezing cylinder and starts to change its consistency. The force or drag on the beater is slowly reduced and the springs of the slip clutch return the assembly to its normal position. The compressor starts and thus keeps the product in the freezing cylinder at the proper consistency.

#### HOW TO ADJUST THE REAR MICRO SWITCH

The firmness of the product depends on the position of the micro switch in relation to the drive assembly.

The compressor must be cut off when the current absorbed by the beater motor is equal to the amperage indicated on the label in the electrical box (B/M Cut-Out Amps.) By using an ammeter across the line feeding the beater motor, it is possible to check the amperage drawn by the motor at the time the micro switch opens.

- a) If a reading indicates an amperage lower than that of the indicated label amperage, the micro switch opens too soon and should be adjusted to move away from the fly wheel.
- b) If a reading indicates an amperage higher than that of the indicated label amperage, the micro switch opens too late and should be adjusted to move toward the fly wheel.

The micro switch is secured to a rectangular mounting plate, fastened to the frame of the machine, but free to rotate

slightly around its retaining belt. Rotation of the plate toward or away from the fly wheel is achieved by turning an adjustment screw (spring loaded), located on the plate itself.

Turning the adjustment screw clockwise will move the micro switch away from the fly wheel. The compressor will cut off later.

Turning the adjustment screw counter clockwise will move the micro switch closer to the fly wheel. The compressor will cut off sooner.

Before adjusting the rear micro switch, refer to the decal inside the electrical box for H.O.M. Cut-Out Amperage.

NOTE - At no time should the H.O.M. Cut-Out Amperage exceed the F.L.A. rating of the beater motor.

#### W A R N I N G

The maximum travel of the disc and assembly is approximately 1/4 of an inch.

In adjusting the distance of the micro switch from the drive assembly, do not increase this distance more than 1/4 of an inch. If this adjustment is increased more than 1/4 of an inch, the drive assembly would never move back far enough to open the normally closed micro switch. Therefore, the compressor and beater motor would run continuously and cause a freeze-up.

The adjustment of the micro switch position requires only slight movements of the assembly in either direction.

---

#### HARD-O-MATIC SPRINGS

The springs are of the best quality and have a very long life expectancy. However, should it become evident that the adjustment of the HOM cannot be achieved by moving the micro switch within the proper range, replacement of the springs is then necessary. Only springs from the original manufacturer should be used.

If the HOM assembly must be taken apart, the following instructions are important and must be observed:

- 1) Grease the inclines of both discs generously.
- 2) Re-assemble the springs with the spacers.
- 3) After tightening the retaining bolt, make sure the disc is not locked but is free to rotate slightly.



## MIX TANK REFRIGERATION

The mix tank is provided with an independent refrigeration system, thermostatically controlled.

### a) How to Adjust the Mix Tank Temperature

The thermostat (TEV) has been preset at the factory to maintain a mix temperature ranging from 35°F to 40°F. The reading is taken at the center of the mix tank.

In the event further adjustment should be desired, proceed as follows:

Mix tank too warm - Turn thermostat (TEV) screw a half turn, clockwise.

Mix tank too cold - Turn thermostat (TEV) screw a half turn, counter clockwise.

Remember, you will have frost on the mix tank walls so for any adjustment beyond a one half turn in either direction, wait at least two hours to observe results.

## ENERGY CONSERVATION SWITCH

Models equipped with this feature allow the operator to switch to a more economical circuit during limited service. During this mode of operation, the product and hopper temperatures are controlled thermostatically. The beater motor is de-energized resulting in a substantial reduction in power input.

### a) How It Operates -

Turn switch to ENERGY CONSERVATION. The beater motor is completely de-energized and the compressor is controlled by the thermostat, TEC.

### b) Calibration of Temperature in the Cylinder

The temperature can be increased or decreased in the cylinder by turning the control in the thermostat (TEC).

### c) Calibration of Temperature in Hopper

The temperature can be increased or decreased in the hopper by turning the control in the thermostat (TEV).

To dispense the product, turn the Selector Switch to AUTO. Wait until the machine has completed one cycle before drawing the product.

The machine will now operate automatically.

## 2) BEATER ACTIVATING SWITCH - Figure 3, Code #1720260

### How It Operates

Two micro switches, located in the housing directly above the spigot head, activate the beater motors; the left micro switch for the left beater motor and the right micro switch for the right beater motor. Both switches must activate simultaneously when the center spigot is opened. They are electrically active when the Selector Switch is in AUTO position and are preset at the factory.

### How To Adjust the Front Micro Switches

Should it become necessary to take the assembly apart for any reason (Figure 4), proper calibration must be maintained. The micro switch must engage and start the beater motor before the product is dispensed from the head. To calibrate, look through the opening at the bottom of the spigot head. Slowly pull the dispensing handle down to raise the piston in the spigot head. The micro switch must be activated (you will hear the click) before you can see the product opening (orifice) inside the head. If this opening shows before you hear the click, the adjustment screw must be raised. Loosen the lock nut under the adjustment screw and turn the screw counter clockwise. Retighten the nut after this adjustment. Adjust the right hand micro switch to activate simultaneously with the left, when the control spigot is opened.

C)

## MAINTENANCE

Your COLDELITE machine has been designed, engineered and manufactured to achieve high performance and long durability.

The life expectancy of any machine does not depend only on the quality of its components and design, but also on the beneficial effects of basic maintenance procedures.

It is important to you, therefore, to become familiar with a few of these basic procedures:

Remove 'O' rings only with the 'O' ring remover furnished with the machine.

Clean the machine according to instructions.

Lubricate all 'O' rings and shaft seals, as instructed.

When reassembling valve, seal and beaters, do not force parts into place. They will fit ~~easier~~ and last longer if you set them in gently and with care.

The wearing out or the improper cleaning of the beater seal will result in leakage from the rear. Check the drip pan frequently and replace the seals, when necessary.

Replace any 'O' ring that has a nick and when the spare parts shipped with the machine are used, reorder immediately. **DO NOT WAIT** until the part is required again.

Never run the machine during the washing and sanitizing operation with the Selector Switch in the AUTO position.

Run the machine only for the time strictly necessary to obtain proper cleaning.

Always wash metal, plastic and rubber parts in lukewarm water. NEVER, NEVER WASH THESE PARTS IN HOT WATER.

Check the belt tension periodically. You should be able to depress the belt about 3/8" at the center between the pulley and the fly wheel.

## W A R N I N G

EXTREME CARE SHOULD BE TAKEN WHEN REMOVING EITHER THE CONTROL PANEL OR THE SIDE AND REAR PANELS.

ALWAYS TURN THE SELECTOR SWITCH TO THE OFF POSITION AND TURN OFF THE DISCONNECT SWITCH ON THE ELECTRICAL SUPPLY LINE BEFORE EXPOSING ANY ELECTRICAL CONNECTIONS OR MECHANICAL MOVING PARTS, SUCH AS, BELTS, PULLEYS AND FAN BLADES.

T R O U B L E S H O T T I N G G U I D E

PROBLEM	PROBABLE CAUSE	SUGGESTED REMEDY
1) No pressure in cylinder  <u>'P' MODEL ONLY</u>	A) Defective check valve. B) Defective 'O' rings on connecting elbow. C) Worn or chipped gears D) Broken drive belt E) Pump assembled incorrectly  F) Frozen mix pump pulley bearing G) Incorrect rotation of pump (3 phase only) H) Gears dry	A) Replace check valve. B) Replace 'O' ring and lubricate. C) File nicks or replace gears. D) Replace belt. E) Disassemble pump and follow illustration on Page F) Call serviceman and replace bearing. G) Change wires to reverse rotation. (See Page H) Lubricate gears
2) Auger will not turn	A) 10 Minute timer broken B) Front micro switch out of calibration or broken.	A) Call serviceman B) " "
3) Product too soft	A) Product drawn faster than machine can produce. B) Rear micro switch out of calibration or defective C) Machine short of gas	A) Slow down on draw rate. B) Call serviceman C) Call serviceman
4) Mix pump does not work  <u>'P' MODEL ONLY</u>	A) Pump lost prime B) No mix in mix tank C) Pump shaft not installed D) Pump belts broken E) Worn pump gears	A) Loosen mix pump hand knobs and B) Add mix to mix tank C) Install pump shaft D) Replace belts E) Replace gears

T R O U B L E   S H O O T I N G   G U I D E

PROBLEM	PROBABLE CAUSE	SUGGESTED REMEDY
5) Nothing comes out of dispensing head	A) No mix in mix tank B) Pump out of prime	A) Add mix to mix tank B) Loosen mix pump hand knobs and pour mix directly into gears.
6) Machine will not freeze	A) Compressor not working B) Short of gas C) Defective or broken rear micro switch D) Defective starter	A) Defective starting capacitor (Single phase only) B) Call serviceman C) Call serviceman D) Call serviceman
7) Machine runs continuously	A) Front micro switch out of calibration B) 10 minute timer stuck in slot. C) No gas D) No mix in cylinder	A) Reset micro switch B) With power off, remove from slot, if necessary or lubricate lightly. C) Call serviceman D) Check pump or gravity feed assembly.
8) Mix tank too warm	A) Low on gas B) Thermostat set too high C) Thermostat defective D) Expansion valve out of adjustment.	A) Call serviceman B) Adjust accordingly. C) Call serviceman D) Call serviceman
9) Banging noise from rear of machine	A) No mix in cylinder B) Cylinder frozen up	A) Proceed as per Problem 1 and 2 B) Turn selector switch to <u>OFF</u> position for one hour. Return to <u>AUTO</u> position.

T R O U B L E S H O O T I N G G U I D E

PROBLEM	PROBABLE CAUSE	SUGGESTED REMEDY
10) Beater motor will not shut off	A) Front micro switch activated	A) Proceed as in Problem #7
11) Machine will not start with Selector Switch in AUTO position	A) No power to machine B) Faulty contactor coils C) Off on overload	A) Check plug, disconnect switch or fuses. Push reset button. B) Call serviceman C) Push reset button, after waiting for reset to cool.
12) Excessive foam in mix tank	A) Defective check valve B) Defective 'O' rings C) Defective gears in pump	A) Replace check valve B) Replace 'O' rings. C) Replace both gears.
13) Short cycle on machine	A) Going off on high pressure  B) Rear micro switches out of adjustment	A) Reset high pressure control. Defective Klixon on compressor. Water not turned on. B) Call serviceman or see Page 18
14) Mix in rear drip chutes	A) Shaft seal missing B) Shaft seal defective C) Seal installed without lubricant D) Pump shaft seal omitted	A) Replace seal. B) Replace seal and lubricate C) Lubricate and replace. D) Install seal and lubricate

T R O U B L E S H O O T I N G G U I D E

PROBLEM	PROBABLE CAUSE	SUGGESTED REMEDY
15) Machine smoking	A) Drive belts are slipping B) Cylinder starved.  C) Cylinder frozen up	A) Turn off machine and tighten belts  B) Reset mix intake tube to add more mix to cylinder. Turn machine <u>OFF</u> Press air relief plunger. Turn Selector Switch to <u>BEATER</u> for one minute. Return to <u>AUTO</u> position. Allow machine to cycle off, then resume normal operation.  C) See Suggested Remedy - 9B
16) Mix drips from rear of head assembly	A) 'O' ring missing or split B) Head not tight	A) Install or replace 'O' ring  B) Tighten hand knobs
17) Low Overrun	A) Defective 'O' ring. Check all 'O' rings. B) Drop of pressure in freezing cylinder C) Pump cover loose	A) Replace any 'O' ring with a nick.  B) Check pressure relief valve.  C) Tighten retaining knobs.

NOTE: Should you encounter a problem not covered above, we suggest you contact your local COLDELITE Distributor or service company for assistance. When you call, be sure that you have all the information on the malfunction with a complete description. The information can usually be given on the phone to correct your problem. Have the model and serial number of your machine available, when you call.

You are always welcome to call the factory, should a problem continue. We are interested in your being another satisfied COLDELITE user.

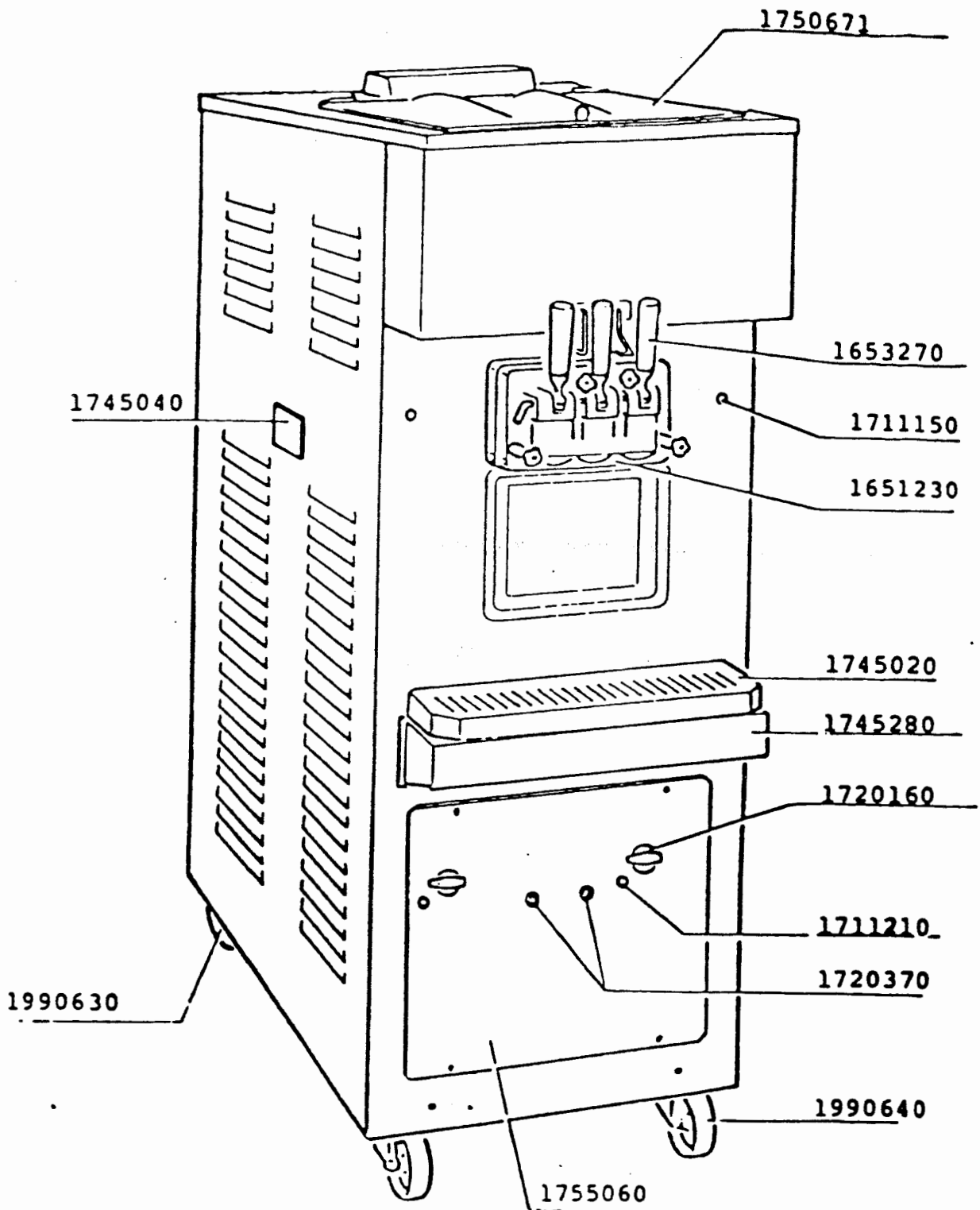
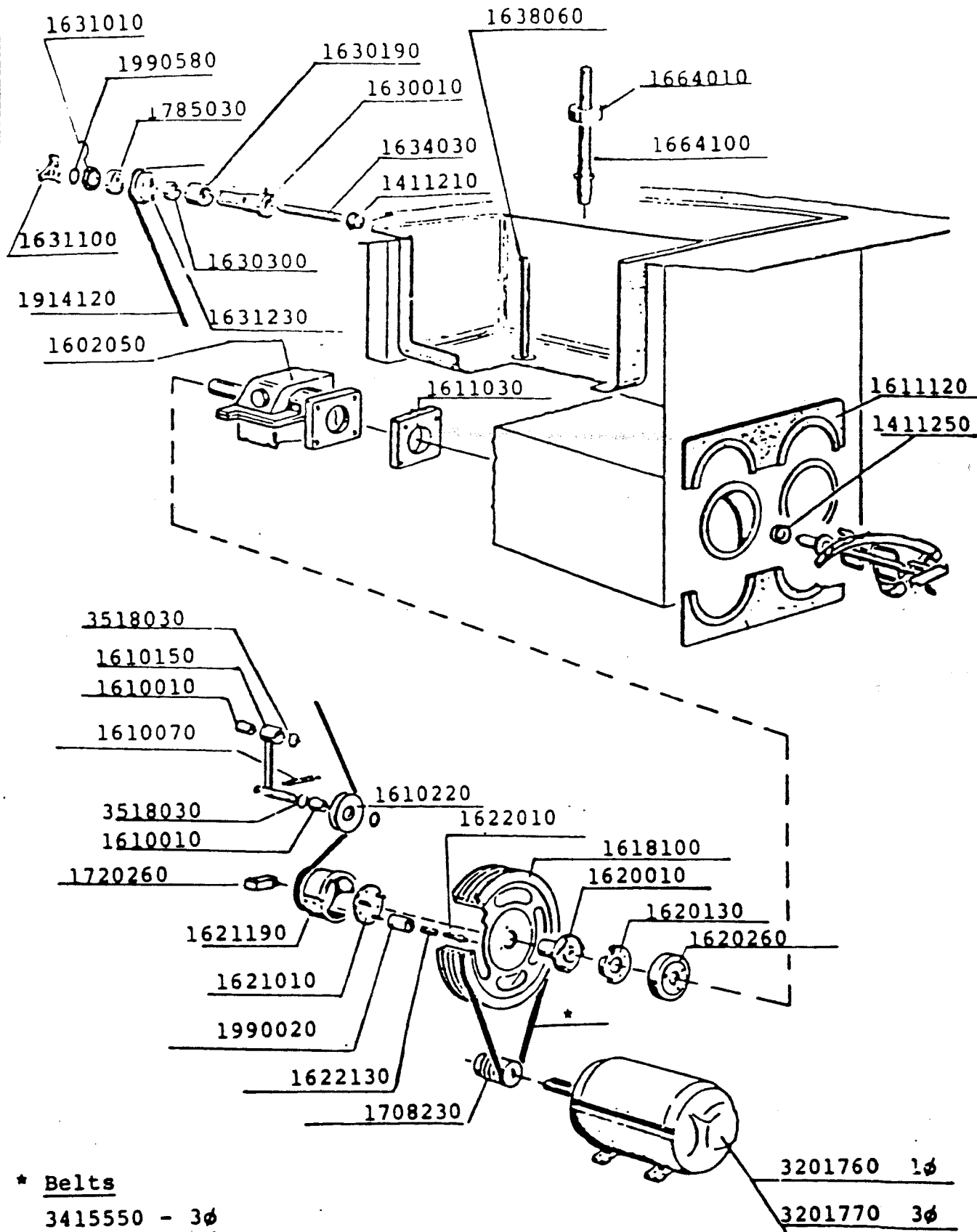

Figure 1





\* Belts

- 3415550 - 3φ
- 3415540 - 1φ

Figure 2

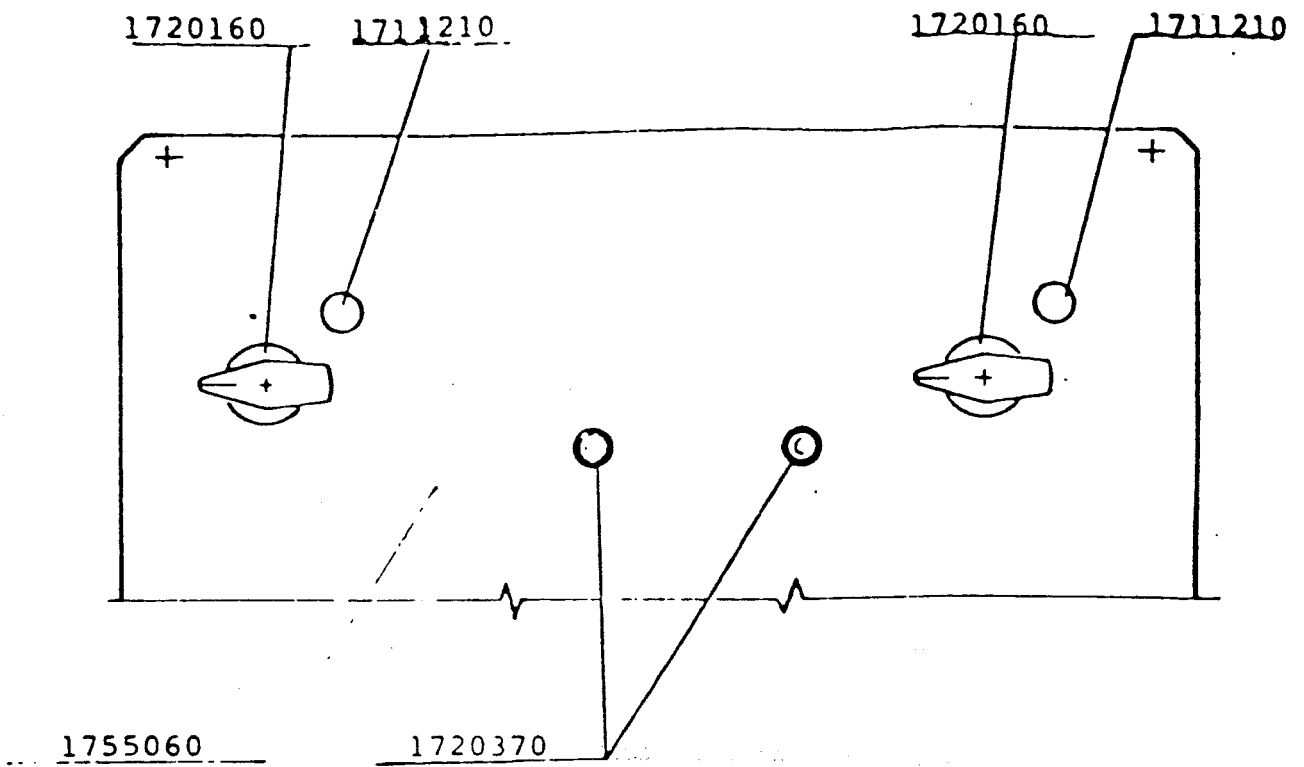

Figure 3

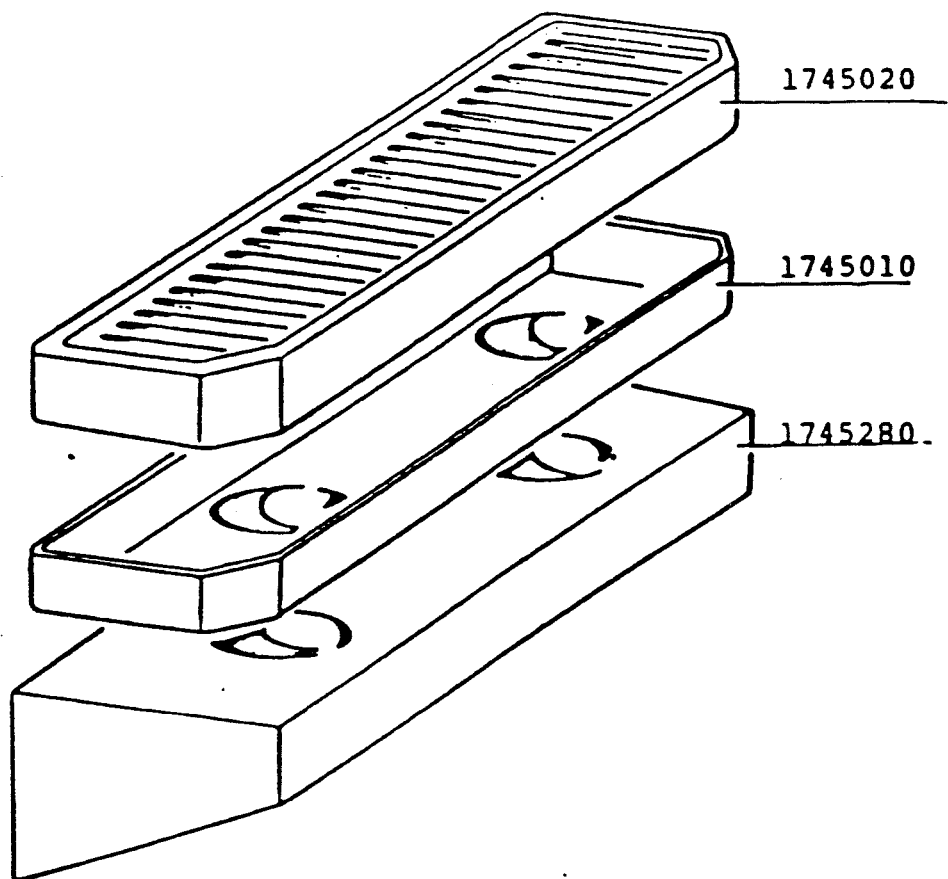

Figure 3a

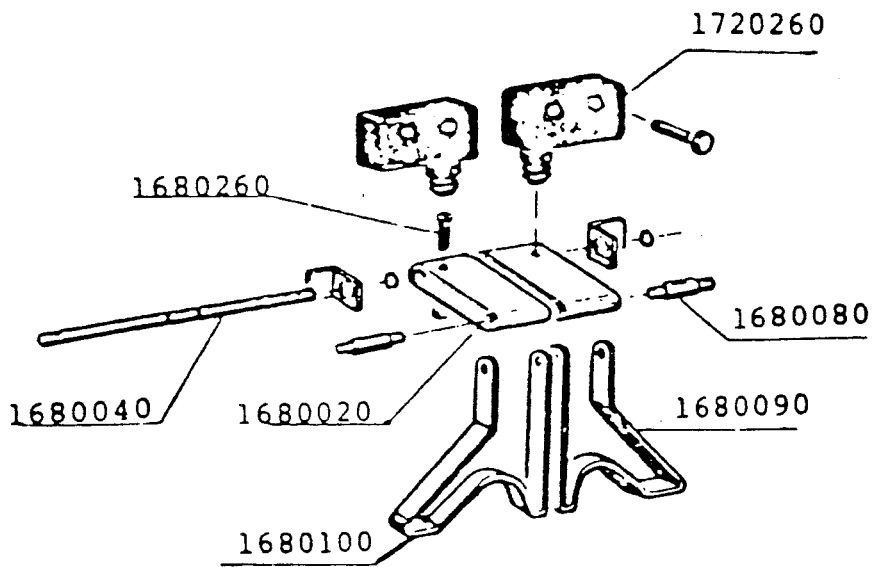

Figure 4

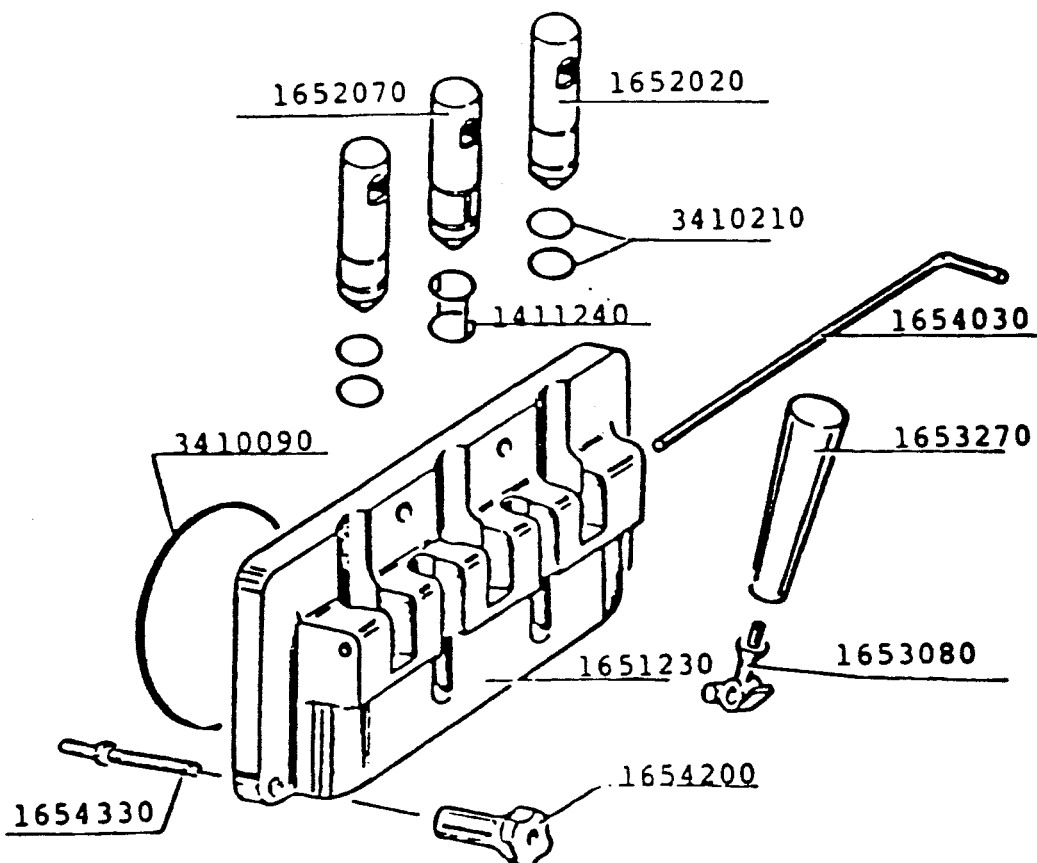

Figure 5

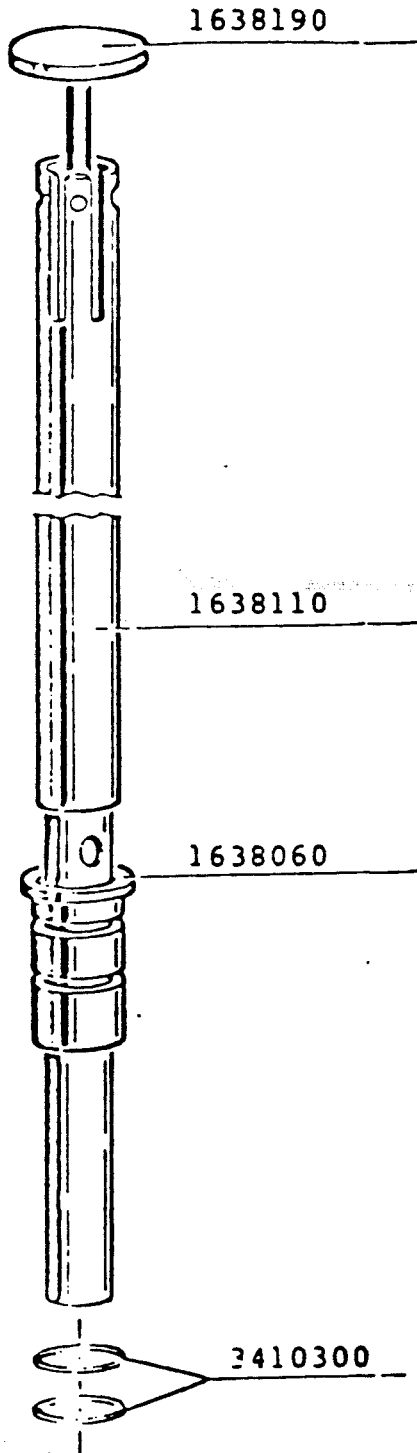

Figure 6

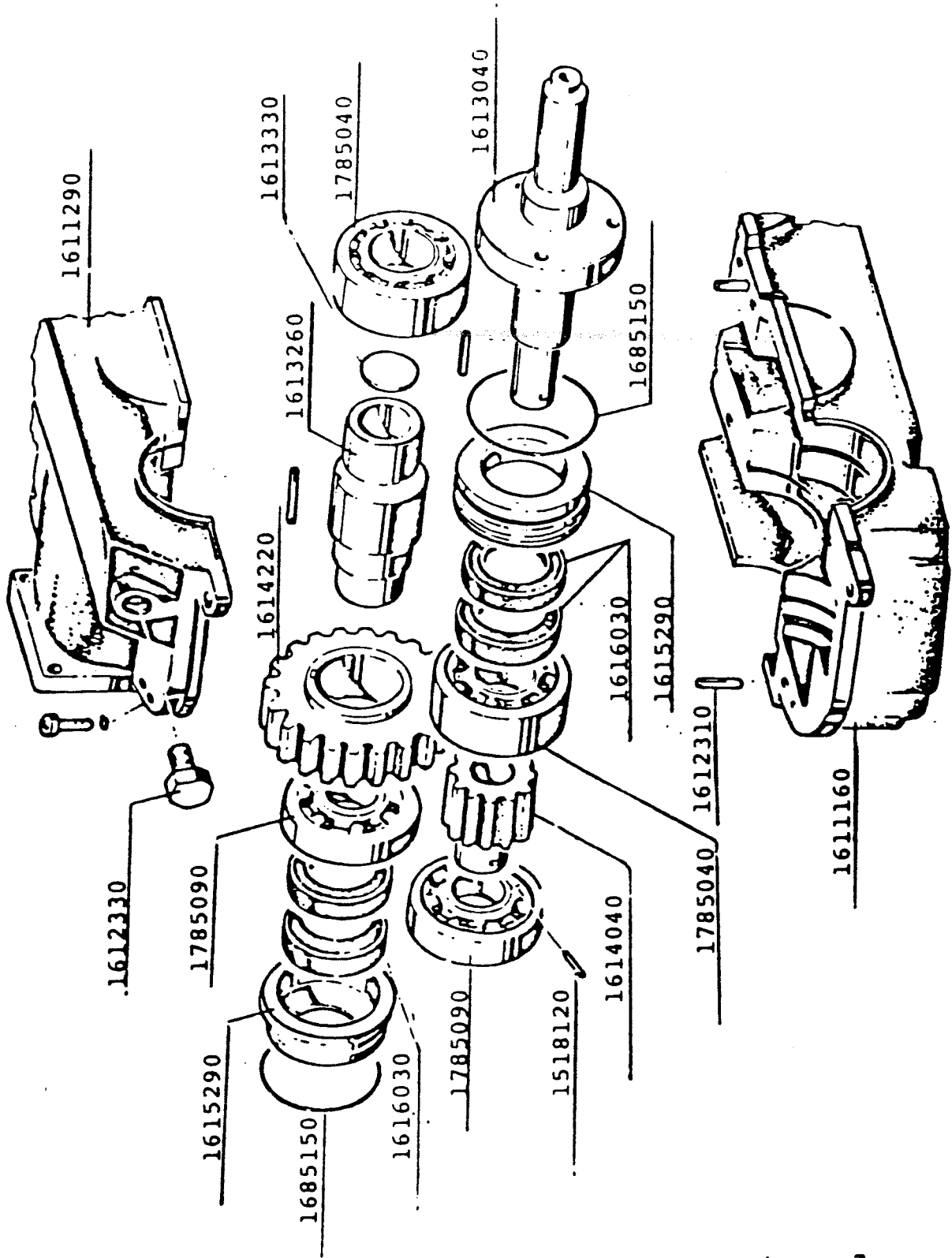

Figure 7

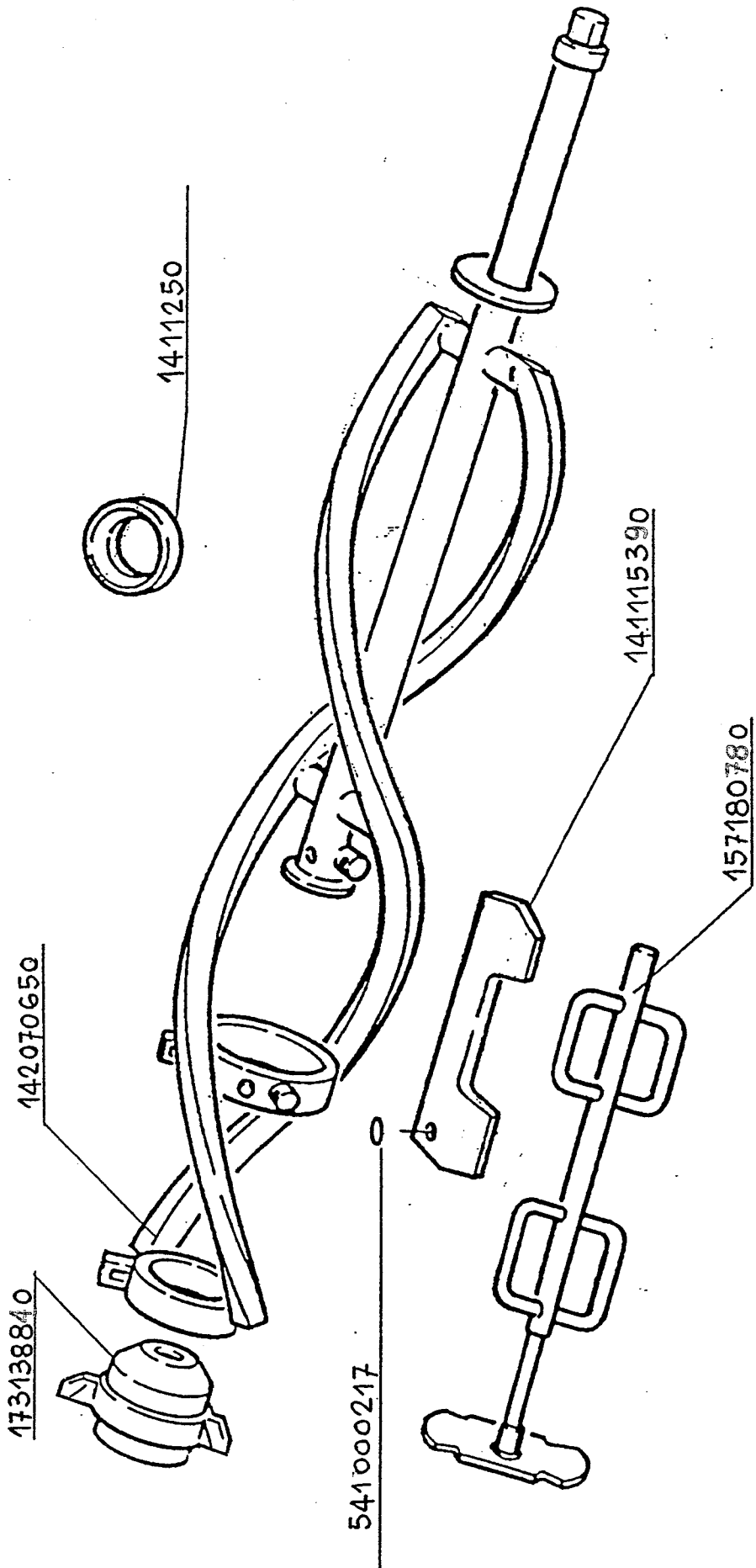
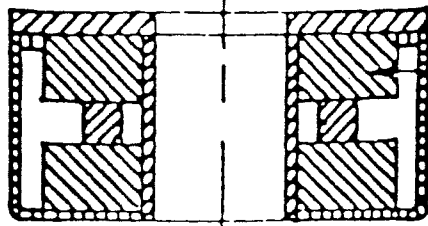
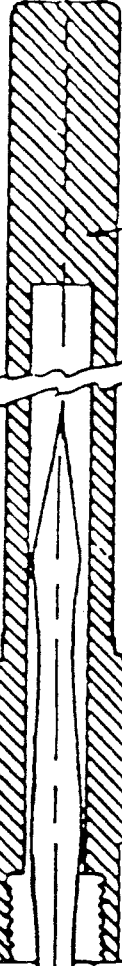

FIG. 8



1664010



1664100

24 VOLT  
FLOAT LEVEL CONTROL

MAGNETIC SWITCH

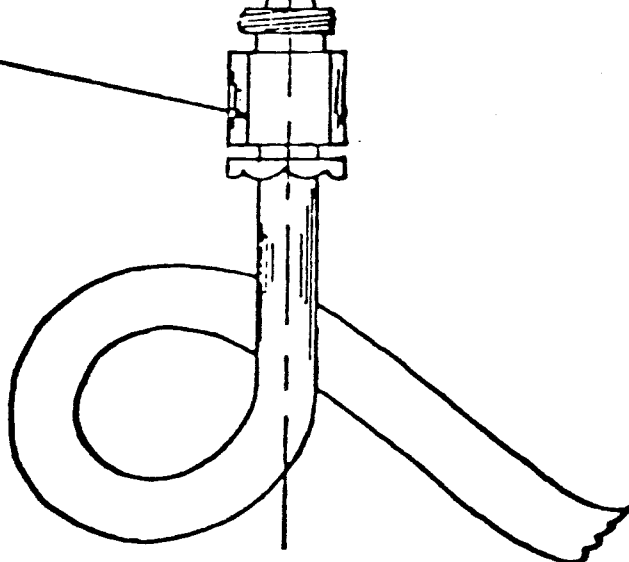

FIG. 9

SPARE PARTS LIST - UF 253 G - E673

Code	Description	Part nr	253
1411240	O RING - central piston	006930	1
1411250	SEAL - beater	010996	2
1518120	PIN - conic	M 6	2
1540130	SPATULA	010687	1
1540140	OR EXTRACTOR - S.S.	002649	1
1602050	GEARBOX ASSY	I.2097	1
1611030	GASKET - plastic - rear	004781	2
1611120	GASKET - front - plastic	002985	1
1611160	HOUSING - lower gearbox	009344	1
1611290	HOUSING - upper gearbox	009343	1
1612310	PIN - gearbox housing key	004824	3
1612330	PLUG - gearbox	004684	1
1613040	SHAFT - drive gear	004827	2
1613260	SHAFT - driven gear	008419	2
1613330	CAP - end - gearbox shaft	004691	2
1614040	GEAR - drive - transmission	009404	2
1614220	GEAR - driven - transmission	009405	2
1615290	SEAL - transmission housing	004826	4
1616030	SEAL - transmission housing	MIM 3050 7	8
1618100	FLY WHEEL - D 235 - Z 3	009138	2
1620010	CLUTCH-- driven slide disk	003381	2
1620130	CLUTCH - drive fixed disk	013174	2
1620260	CLUTCH COVER - plastic		2
1621010	CLUTCH - spring base	003423	2
1621190	HOM COVER - w/pulley - D 100	ISPZ - 100 - 70	2
1622010	CLUTCH - stud	003383	6
1622130	CLUTCH - spring	015025	6
1625020	BRACKET - rear micro	010711	2
1625110	BRACKET - rear micro - frame	015133	1
1625150	SPRING - rear micro adjustm.	010764	4
1638060	GRAVITY FEED TUBE		2
1638110	SLEEVE - gravity feed tube		2
1638190	SPLASH GUARD - gravity feed		2
142070650	BEATER - only - 2E - long	017175	2
157180690	IDLER - for 2E beater		2
173138840	END PUSHER - 2Eg beater		2
1651230	SPIGOT HD BODY - w/pin no/sp	no spacer	1
1652020	PISTON	003157	2
1652070	PISTON - center	007121	1
1653080	CAM - piston activating		3
1653270	HANDLE - plastic only		3
1654030	ROD - spigot head	002802	1
1654200	KNOB - medium - spigot head	004503	4
1654330	STUD - retaining knob-spigot	003169	4
1664010	FLOAT ONLY	001817	2
1664100	STEM - float control S.S.		2
1680020	CAM - front micro	006367	2
1680040	ROD - front micro switch	006366	1
1680080	PIN - nylon - front micro	004795	2
1680090	LEVER - right - front micro	010887	1
1680100	LEVER - left - front micro	010888	1
1680260	ADJ.SCREW - front micro	vit	2
1685150	O RING - 159 - gearbox seal	OR 159	4
1708230	PULLEY - beater motor -	3Z - 47	2
1711030	BULB - 24 Volt	2130.0 24 Volt	2



SPARE PARTS LIST - UF 253 G - E673

Code	Description	Part nr	253
1711150	CAP PILOT LIGHT - orange M13	5389-04	2
1711210	CAP PILOT LIGHT - clear	5389-00 M 13	2
1720070	SEAL - for switch 1720...	006965	2
1720160	SWITCH-selector	# 39255-Breter	2
1720260	MICROSWITCH - Burgess 3 BR	3 BR	4
1720370	RESET BUTTON - complete	I 2003	2
1723100	TIMER - fiber 24 Volt	EA55 10' - 2"	2
1724350	CONTACTOR - 24 volt	B16-40-00	4
1724490	RELAY - fem 24 VOLT	RCP11/3D/5/24 V.	2
1724590	OVERLOAD - 8.5-13 Amp.	T 25 8.5-13Amp.	2 s
1724650	OVERLOAD - 3.7-5.5 Amp.	T 25 3.7-5.5 Amp.	2 t
1724800	SOLE - 24 volt for 17272...		2
1725110	TERMO. - Danfoss	077B0103-02	4
1727270	SOLENOID - 24 Volt	EVR3 - 24 Volt	1
1727280	VALVE BODY - solenoid		2
1727500	VALVE - thermostatic - danfo	TY2 MOP 30	2
1727560	VALVE - automatic - flica	FLICA AMC	2
1727800	NOZZLE # 2 - for 17275...		2
1727831	NOZZLE # 2 - for 1727560		2
1727840	ORFICE # 2 for 1727560	FLICA	2
1730040	CONDENSOR - water		1
1731150	CONDENSOR - air		1
1740090	FAN BLADE	D.400 18*	1
1740310	BRACKET-fan motor		1
1745010	DRIP TRAY - front	006865	1
1745020	COVER - for 1745010	006866	1
1745040	DRIP TRAY - rear - L 450	006885	2
1745280	CONSOLE - front drip tray	005529	1
1745320	SCREW- support front console	004348	2
1750671	COVER - mix tank - beige		1
1750060	COVER - electric box		1
1755430	PROTECTION-cover electr. box		1
1775080	COVER - pump hub hole		9
1780260	DECAL - front & rear		2
1780320	DECAL-warning-safety		2
1785040	BALL BEARING - 3206	3AANO-30	4
1785090	BALL BEARING - 6206	3A 30	4
1785370	ROLL-RIV	8x8	2
1902160	PANEL - left side		1
1903150	PANEL - right side		1
1904180	PANEL - rear - upper - water		1
1904190	PANEL - rear - upper - air		1
1905170	PANEL - rear - lower - air		1
1905180	PANEL - rear - lower - water		1
1906160	PANEL - front - upper		1
1906180	PANEL - front - lower		1
1990020	BUMPER - horn	014944	6
1990200	GREASE-TIVELLA	x 1 PT	1
1990430	COVER expansion valve-small	007062	2
1990630	CASTER - swivel w/ brake		2
1990640	CASTER - rigid		2
3201760	MOTOR - 1.5 Hp- 115/220/60/1	8-173492	2
3201770	MOTOR - 1.5 Hp- 230/460/60/3	8-173456	2
3203100	BASE - fan motor 3203110	161 L 113 AN 3	1
3203110	MOTOR - fan - 230/60/1-1/8HP	5KSP39DG69885	1

SPARE PARTS LIST - UF 253 G - E673

Code	Description	Part nr	253
1711150	CAP PILOT LIGHT - orange M13	5389-04	2
1711210	CAP PILOT LIGHT - clear	5389-00 M 13	2
1720070	SEAL - for switch 1720...	006965	2
1720160	SWITCH-selector	# 39255-Breter	2
1720260	MICROSWITCH - Burgess 3 BR	3 BR	4
1720370	RESET BUTTON - complete	I 2003	2
1723100	TIMER - fiber 24 Volt	EA55 10' - 2"	2
1724350	CONTACTOR - 24 volt	B16-40-00	4
1724490	RELAY - fema 24 VOLT	RCP11/3D/5/24 V.	2
1724590	OVERLOAD - 8.5-13 Amp.	T 25 8.5-13Amp.	2 s
1724650	OVERLOAD - 3.7-5.5 Amp.	T 25 3.7-5.5 Amp.	2 t
1724800	COIL - 24 volt for 17272..		2
1725110	TERMO. - Danfoss	077B0103-02	4
1727270	SOLENOID - 24 Volt	EVR3 - 24 Volt	1
1727280	VALVE BODY - solenoid		2
1727500	VALVE - thermostatic - danfo	TY2 MOP 30	2
1727560	VALVE - automatic - flica	FLICA AMC	2
1727800	NOZZLE # 2 - for 17275..		2
1727831	NOZZLE # 2 - for 1727560		2
1727840	ORFICE # 2 for 1727560	FLICA	2
1730040	CONDENSOR - water		1
1731150	CONDENSOR - air		1
1740090	FAN BLADE	D.400 18*	1
1740310	BRACKET-fan motor		1
1745010	DRIP TRAY - front	006865	1
1745020	COVER - for 1745010	006866	1
1745040	DRIP TRAY - rear - L 450	006885	2
1745280	CONSOLE - front drip tray	005529	1
1745320	SCREW- support front console	004348	2
1750671	COVER - mix tank - beige		1
1755060	COVER - electric box		1
1755430	PROTECTION-cover electr. box		1
1775080	COVER - pump hub hole		9
1780260	DECAL - front & rear		2
1780320	DECAL-warning-safety		2
1785040	BALL BEARING - 3206	3AANO-30	4
1785090	BALL BEARING - 6206	3A 30	4
1785370	ROLL-RIV	8x8	2
1902160	PANEL - left side		1
1903150	PANEL - right side		1
1904180	PANEL - rear - upper - water		1
1904190	PANEL - rear - upper - air		1
1905170	PANEL - rear - lower - air		1
1905180	PANEL - rear - lower - water		1
1906160	PANEL - front - upper		1
1906180	PANEL - front - lower		1
1990020	BUMPER - horn	014944	6
1990200	GREASE-TIVELLA	x 1 PT	1
1990430	COVER expansion valve-small	007062	2
1990630	CASTER - swivel w/ brake		2
1990640	CASTER - rigid		2
3201760	MOTOR - 1.5 Hp- 115/220/60/1	8-173492	2
3201770	MOTOR - 1.5 Hp- 230/460/60/3	8-173456	2
3203100	BASE - fan motor 3203110	161 L 113 AN 3	1
3203110	MOTOR - fan - 230/60/1-1/8HP	5KSP39DG69885	1

SPARE PARTS LIST - UF 253 G - E673

Code	Description	Part nr	253
3213080	TRANSFORMER - 150 W. 230/24	50-0150-610	1
3250110	CAPACITOR-START/comp. 3302090	014-0006-07	2
3250310	CAPACITOR RUN/comp. 3302090	014-0037-11	2
3250590	RELAY-COMPR-2Hp-3302090	040-0001-20	2
3302090	COMPRESSOR - 2HP - 230/60/1	CRD1-0200-PFV #230	2
3302100	COMPRESSOR - 2HP - 220/60/3	CRD1-0200-TF5 #270	2
3304100	VALVE - water - 3/8"	56-30	2
3305150	LIQUID INDICATOR	SA 13 FM	2
3305210	FILTER DRYER	C-163	2
3306390	PRESSURE CONTROL-250/380 lbs	MG 21-1582	2
3310060	CAPAC & REL A/y for 3302090	514-3199-56	2
3403100	GAS - refrigerant R 502	R 502	81b
3410090	O RING - 342	OR-342-10V 70 #283	2
3410210	O RING - 215	OR 215	4
3410300	O RING - 113 or (118)	OR 113	8
3410310	O RING - 112	112	2
3415540	BELT - 1020 MM		6 s
3415550	BELT - 1060 MM		6 t
3540100	STERASHEEN		5
3540110	PETROGEL		1
3540250	BRUSH - 3/8" x 12"	001138	1
3540260	BRUSH - 3/4" x 12"	4138-N	1
3540270	BRUSH - 1 1/2 x 12"	8138-N	1
5555320	MINOR TUNUP KIT		1



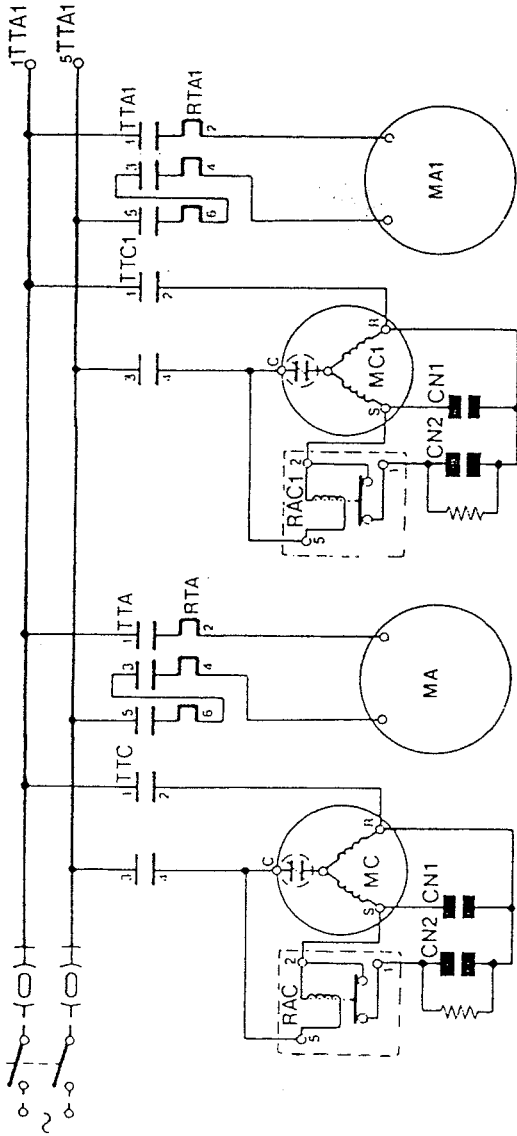

	1-2	1-4	2-9	2-5	4-11	4-7
	AB	AC	BD	BE	CF	CG
FERMO	-	-	-	-	*	-
CONSERVAZIONE	*	*	*	*	*	*
DISTRIBUZIONE	*	*	*	*	*	*
PULIZIA	*	*	*	*	*	*

CR = CR1-BR 39255

- \* Fermo - Off
- \* Conservazione - Energy Conservation
- \* Distribuzione - Auto.
- \* Pulizia - Beater

