

Applies To: **See VEHICLES AFFECTED****December 2002**

## Safety Recall: Ignition Switch

(Supersedes 02-031, dated September 2002)

### BACKGROUND

Electrical contacts in the ignition switch can wear prematurely due to high electrical current passing through the switch. Worn-out ignition contacts could cause the engine to stall without warning. Although the engine will restart in most cases, a vehicle that stalls while driving increases the risk of a crash.

### VEHICLES AFFECTED

- 1997–99 Accord (L4)
- 1998–99 Accord (L4 and V6)
- 1998–99 Civic
- 1997–99 CR-V
- 1997–99 Odyssey
- 1997–99 Prelude

**Not every vehicle in the years and models listed above is affected by this campaign.** Before beginning work, verify that the vehicle is eligible by checking your campaign responsibility report.

### CUSTOMER NOTIFICATION

All owners of affected vehicles must be sent a notification letter of this campaign. An example of the customer notification letter was sent with this service bulletin.

### CORRECTIVE ACTION

Replace the electrical (ignition) switch.

**NOTE:** *Reinstalling aftermarket parts (security systems, alarms, audio systems, etc.) connected to the ignition wiring is not covered under this campaign.* If a customer wants a non-Honda part reinstalled, the customer (or the shop that installed the part) must do the work and assume liability. In addition, the customer is responsible for all costs associated with the non-Honda part and its installation. If you have any questions about this, please contact the Export Service Department.

### PARTS INFORMATION

Ignition Switch:

- |   |   |                   |
|---|---|-------------------|
| 1997 Accord   | – | P/N 35130-SY8-305 |
| 1998–99 Accord  | – | P/N 35130-S84-305 |
| 1998–99 Civic<br>(left-hand drive)                                    | – | P/N 35130-S04-305 |
| 1999 Civic<br>(right-hand drive)                                      | – | P/N 35130-S04-306 |
| 1997–98 CR-V<br>(right-hand drive, <i>with</i> immobilizer system)    | – | P/N 35130-S10-305 |
| 1999 CR-V<br>(right-hand drive, <i>with</i> immobilizer system)       | – | P/N 35130-S10-406 |
| 1997–98 CR-V<br>(left-hand drive, <i>with</i> immobilizer system)     | – | P/N 35130-S10-306 |
| 1999 CR-V<br>(left-hand drive, <i>with</i> immobilizer system)        | – | P/N 35130-S10-405 |
| 1997–99 CR-V<br>(right-hand drive, <i>without</i> immobilizer system) | – | P/N 35130-S10-305 |
| 1997–99 CR-V<br>(left-hand drive, <i>without</i> immobilizer system)  | – | P/N 35130-S10-306 |
| 1997 Odyssey<br>(left-hand drive)                                     | – | P/N 35130-SX0-406 |
| 1997 Odyssey<br>(right-hand drive)                                    | – | P/N 35130-SX0-405 |
| 1998 Odyssey<br>(left-hand drive)                                     | – | P/N 35130-SX0-305 |
| 1999 Odyssey<br>(left-hand drive)                                     | – | P/N 35130-S0X-305 |
| 1998–99 Odyssey<br>(right-hand drive)                                 | – | P/N 35130-SX0-306 |
| 1997–99 Prelude   | – | P/N 35130-S30-305 |

### TOOL INFORMATION

Terminal Pin Tool: P/N 07JAZ-002000A  
(part of Terminal Pin Tool Set,  
P/N 07JAZ-002000A)

## WARRANTY CLAIM INFORMATION

Description	FRT
Replace ignition switch	
1997 Accord	0.5
1998–99 Accord	0.4
1998–99 Civic	0.6
1997–99 CR-V	0.4
1997–98 Odyssey	0.4
1999 Odyssey	0.7
1997–99 Prelude	0.5

Operation Number: 725108

Failed Part: P/N 35130-S84-A01

Defect Code: 5B0 (the "0" is a zero)

Contention Code: L55

## REPAIR PROCEDURE

- Use **Procedure A** on 1997 Accords (L4).
- Use **Procedure B** on 1998–99 Accords (L4 and V6).
- Use **Procedure C** on 1998–99 Civics.
- Use **Procedure D** on 1997–99 CR-Vs.
- Use **Procedure E** on 1997–98 Odysseys.
- Use **Procedure F** on 1999 Odysseys.
- Use **Procedure G** on 1997–99 Preludes.

### Procedure A: 1997 Accords (L4)

1. Remove the dashboard lower cover, the knee bolster, and the steering column covers (see the 1997 Accord Shop Manual).
2. Disconnect the 7P and 8P connectors from the ignition switch body.

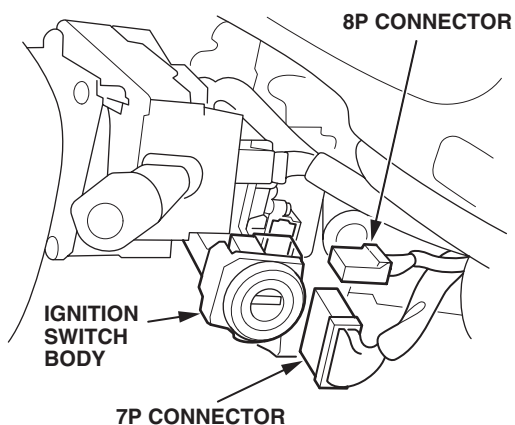

3. Remove the steering column holder mounting bolts and nuts. Lower the steering column.

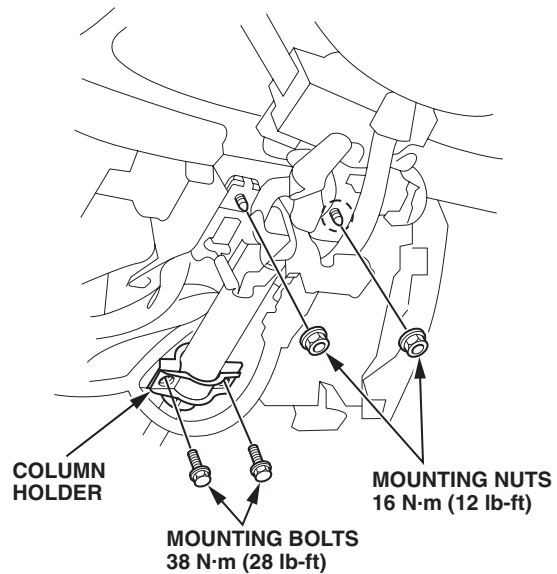

4. Center-punch both shear bolts on the ignition switch body, and drill off each bolt head with a 5 mm (3/16 in.) drill bit. Be careful not to damage the switch body.

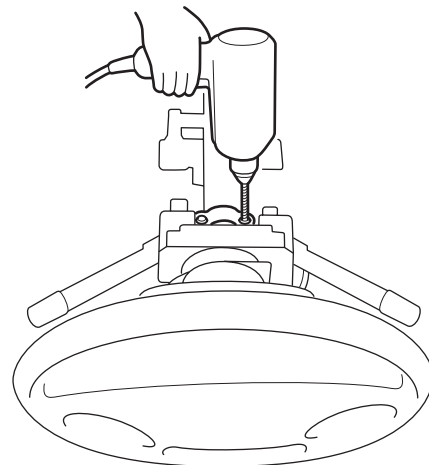

5. Remove the shear bolts from the ignition switch body, and discard them. Then separate the switch body from the steering column.

- Remove the screws from the electrical switch, then remove the electrical switch from the ignition switch body. Discard the electrical switch.

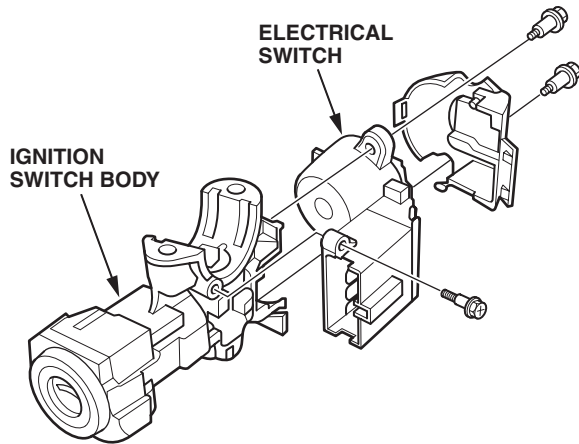

- Install the new electrical switch with the original screws.
- Hold the ignition switch body up to the steering column, and loosely install the new shear bolts.
- Insert the key in the ignition switch. Make sure the key turns freely, and the steering column lock works correctly.
- Tighten the shear bolts until the hex heads twist off.

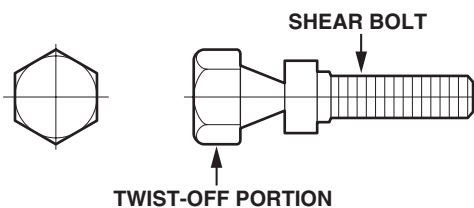

- Raise the steering column, and install it with its mounting bolts and nuts. Torque the bolts to 38 N·m (28 lb-ft) and the nuts to 16 N·m (12 lb-ft).
- Connect the 7P and 8P connectors.
- Install the steering column covers, the knee bolster, and the dashboard lower cover.
- Center-punch a completion mark above the eighth character of the engine compartment VIN.



### Procedure B: 1998–99 Accords (L4 and V6)

- Remove the dashboard lower cover (see the 1998–02 Accord Shop Manual).
- Disconnect the ignition switch harness 6P connector from the driver's under-dash fuse/relay box.

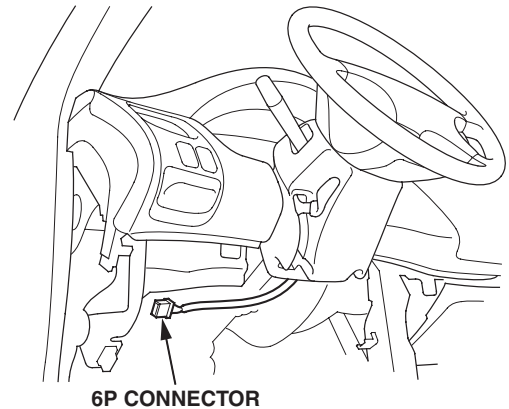

- Remove the steering column covers (see the shop manual).
- Note how the ignition (electrical) switch harness routes to the fuse box; you'll need to route the new switch harness the same way.
- Make sure the ignition switch is turned to LOCK (0).
- Remove the screw from the side of the electrical switch cover.

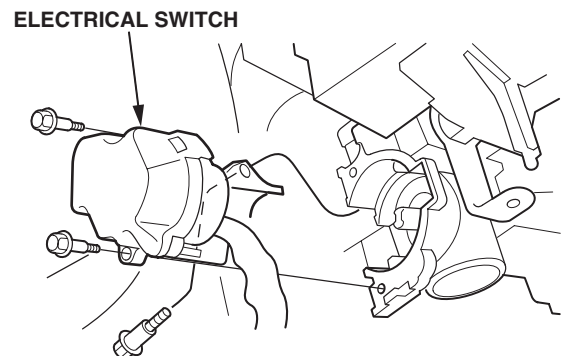

- Remove the screws from the electrical switch, then remove and discard the switch and its harness.
- Install the new electrical switch with the original screws and cover. Route its harness to the fuse box the same way the discarded harness was routed.
- Connect the 6P connector.
- Install the steering column covers and the dashboard lower cover.
- Center-punch a completion mark above the eighth character of the engine compartment VIN.



**Procedure C: 1998–99 Civics**

1. Remove the driver's dashboard lower cover and the knee bolster (see the 1996–00 Civic Shop Manual).
2. Disconnect the ignition switch harness 5P connector from the under-dash fuse/relay box and the 7P connector from the main wire harness.

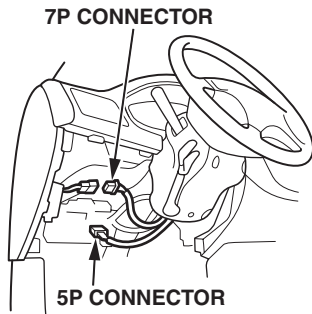

3. Remove the steering column covers (see page 17-37 of the service manual).
4. Note how the ignition (electrical) switch harness routes to the fuse box and main harness; you'll need to route the new switch harness the same way.
5. Remove and discard the wire tie clips from the 7P connector main wire harness. (Part of the harness will be reused.)
6. Remove the secondary lock from the 7P connector.

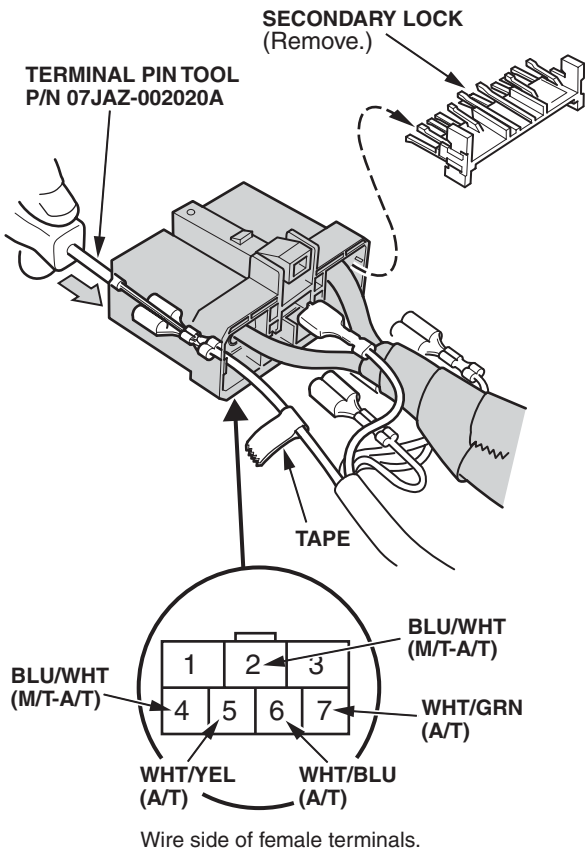

7. Remove terminals 2 and 4 (M/T vehicles) or terminals 2, 4, 5, 6, and 7 (A/T vehicles) from the 7P connector using the Terminal Pin Tool (P/N 07JAZ-002000A).

NOTE: Terminals 2 and 4 have BLU/WHT wires. To avoid mixing them up, label terminal 4 with a small piece of tape.

8. Make sure the ignition switch is turned to LOCK (0).
9. Remove the screws from the electrical switch, then remove and discard the switch and its harness.

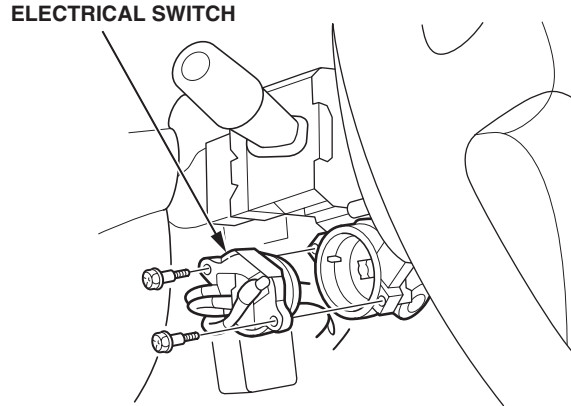

10. Install the new electrical switch with the original screws.
11. Remove the secondary lock from the 7P connector of the new main harness.

12. Install the terminals you removed from the original 7P connector into the new 7P connector.

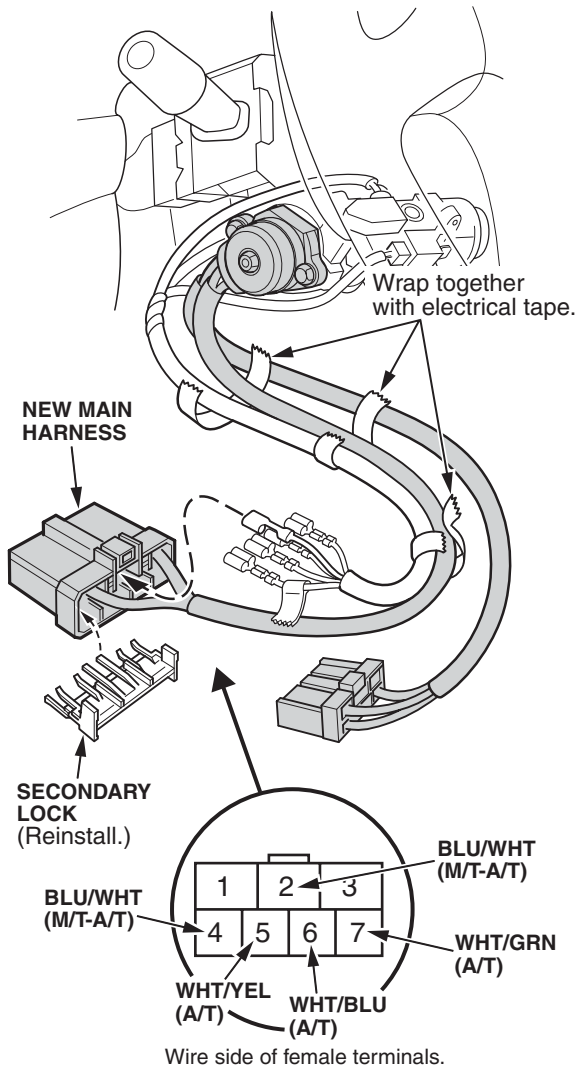

13. Wrap both parts of the 7P main harness together with electrical tape.
14. Attach the new wire tie clips to the main harness in the same position as the original ties.
15. Route and attach the ignition switch harness and main harness the same way the original harnesses were installed.
16. Connect the 5P and 7P connectors.
17. Install the steering column covers, the knee bolster, and the driver's dashboard lower cover.

18. Center-punch a completion mark above the eighth character of the engine compartment VIN.

Center-punch here.

**2HGEJ6XXXXHXXXXXX**

#### Procedure D: 1997–99 CR-Vs

1. Remove the driver's dashboard lower cover and the knee bolster (see the 1997–01 CR-V Shop Manual).
2. Disconnect the ignition switch harness 5P connector from the under-dash fuse/relay box and the 3P connector from the main wire harness.

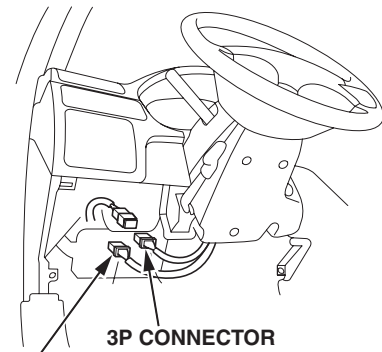

3. Remove the steering column covers (see the shop manual).
4. Note how the ignition (electrical) switch harness routes to the fuse box and main wire harness; you'll need to route the new switch harness the same way.
5. Make sure the ignition switch is turned to LOCK (0).
6. Remove the screws from the electrical switch, then remove and discard the switch and its harness.

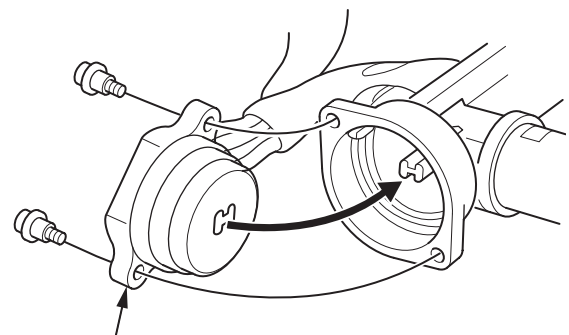

7. Install the new electrical switch with the original screws. Route its harness to the fuse box and main wire harness the same way the discarded harness was routed.
8. Connect the 5P and 3P connectors.

9. Install the steering column covers, the knee bolster, and the driver's dashboard lower cover.
10. Center-punch a completion mark above the eighth character of the engine compartment VIN.

Center-punch here.

**JHLRD1XXXXHXXXXXX**

**Procedure E: 1997–98 Odysseys**

1. Remove the dashboard lower cover, the knee bolster, and the steering column covers (see the 1998 Odyssey Shop Manual).
2. Disconnect the ignition switch harness 7P connector from the under-dash fuse/relay box.

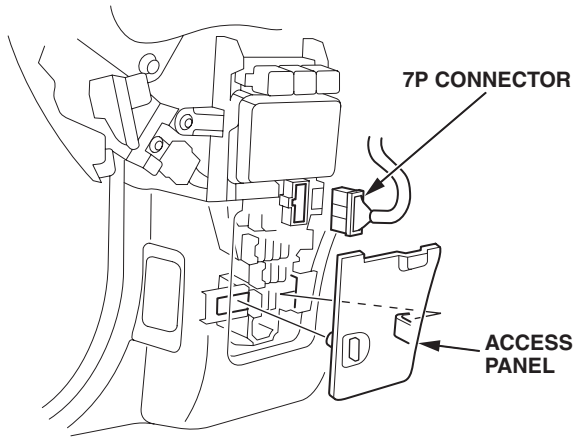

3. Note how the ignition (electrical) switch harness routes to the fuse box; you'll need to route the new switch harness the same way.
4. Make sure the ignition switch is turned to LOCK (0).
5. Remove the screws from the electrical switch, then remove and discard the switch and its harness.

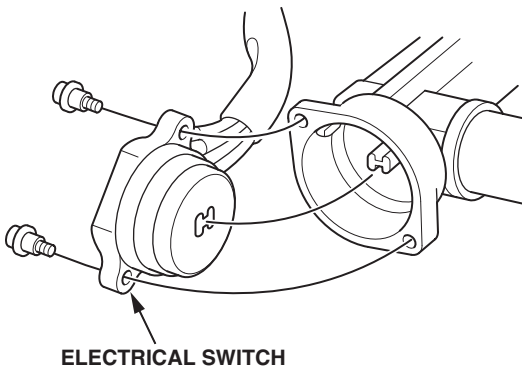

6. Install the new electrical switch with the original screws. Route its harness to the fuse box the same way the discarded harness was routed.
7. Connect the 7P connector.
8. Install the steering column covers, the knee bolster, and the dashboard lower cover.

9. Center-punch a completion mark above the eighth character of the engine compartment VIN.

Center-punch here.

**JHMRA1XXXXHXXXXXX**

**Procedure F: 1999 Odysseys**

1. Remove the dashboard lower cover (see the 1999–02 Odyssey Shop Manual).
2. Remove the driver's door sill molding and the left kick panel (see the shop manual).
3. Remove the mounting nut and detach the clips from the driver's under-dash fuse/relay box. Pull the fuse box away from the body.

**DRIVER'S UNDER-DASH FUSE/RELAY BOX**

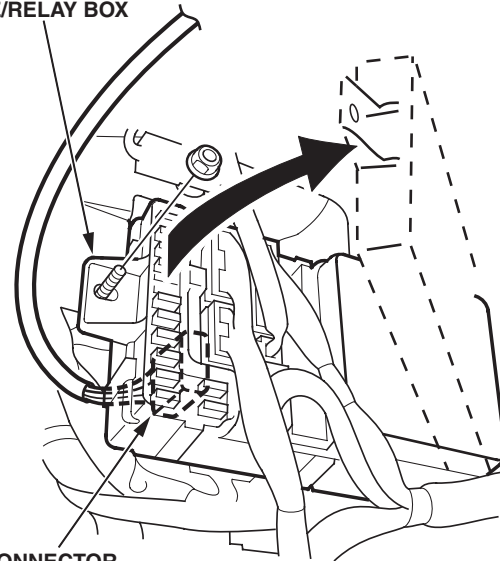

**6P CONNECTOR**  
(Located on the back of the fuse box.)

4. Disconnect the ignition switch harness 6P connector from the back of the fuse box.
5. Remove the steering column covers (see the shop manual).
6. Note how the ignition (electrical) switch harness routes to the fuse box, the main harness, and the ignition switch body; you'll need to route the new switch harness the same way.

7. Disconnect the ignition switch harness 4P connector from the main harness. Then disconnect its 5P connector from the ignition switch body.

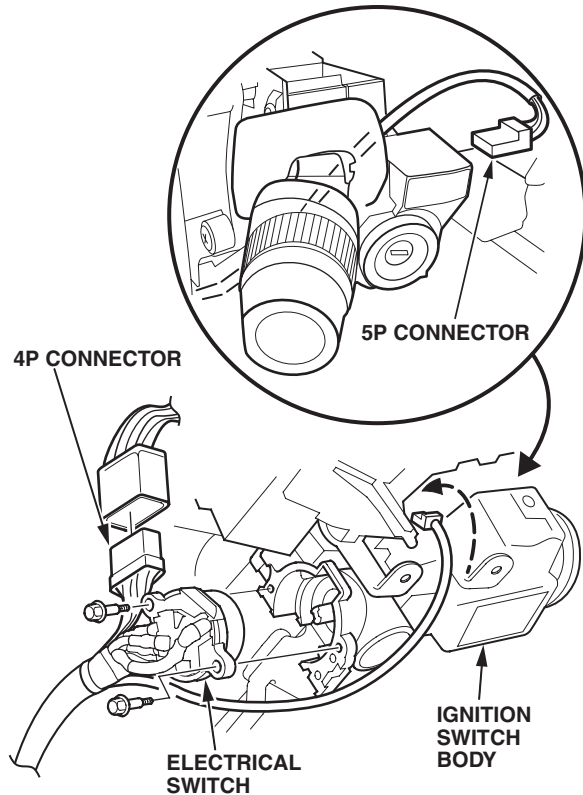

8. Make sure the ignition switch is turned to LOCK (0).
9. Remove the screws from the electrical switch, then remove and discard the switch and its harness.
10. Install the new electrical switch with the original screws. Route its harness to the fuse box the same way the discarded harness was routed.  
NOTE: To avoid harness damage, make sure you route the 5P connector portion of the harness the exact way the original harness was routed.
11. Connect the 5P connector to the ignition switch body, the 4P connector to the main harness, and the 6P connector to the fuse box.
12. Install the fuse box.
13. Install the door sill molding, the kick panel, the steering column covers, and the dashboard lower cover.
14. Center-punch a completion mark above the eighth character of the engine compartment VIN.

Center-punch here.

**2HKRL1XXXXHXXXXXX**

#### Procedure G: 1997–99 Preludes

1. Remove the steering column covers (see the 1997–99 Prelude Shop Manual).
2. Make sure the ignition switch is turned to LOCK (0).
3. Disconnect the 7P connector from the ignition switch body.

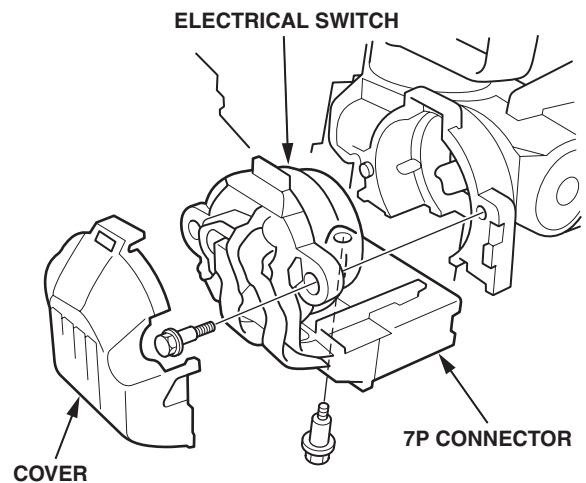

4. Remove the cover from the electrical switch, then remove the screws. Remove and discard the electrical switch and its harness.
5. Install the new electrical switch with the original screws and cover.
6. Connect the 7P connector.
7. Install the steering column covers.
8. Center-punch a completion mark above the eighth character of the engine compartment VIN.

Center-punch here.

**JHMBB6XXXXHXXXXXX**