



Delta Environmental
Products, Inc.

Pentair Water

DGF12 System

Low Pressure Sewage System

Installation and Service Manual

For use with the following Delta grinder pumps:

- D1P20 (shown on cover)
- D1C20
- D2C20

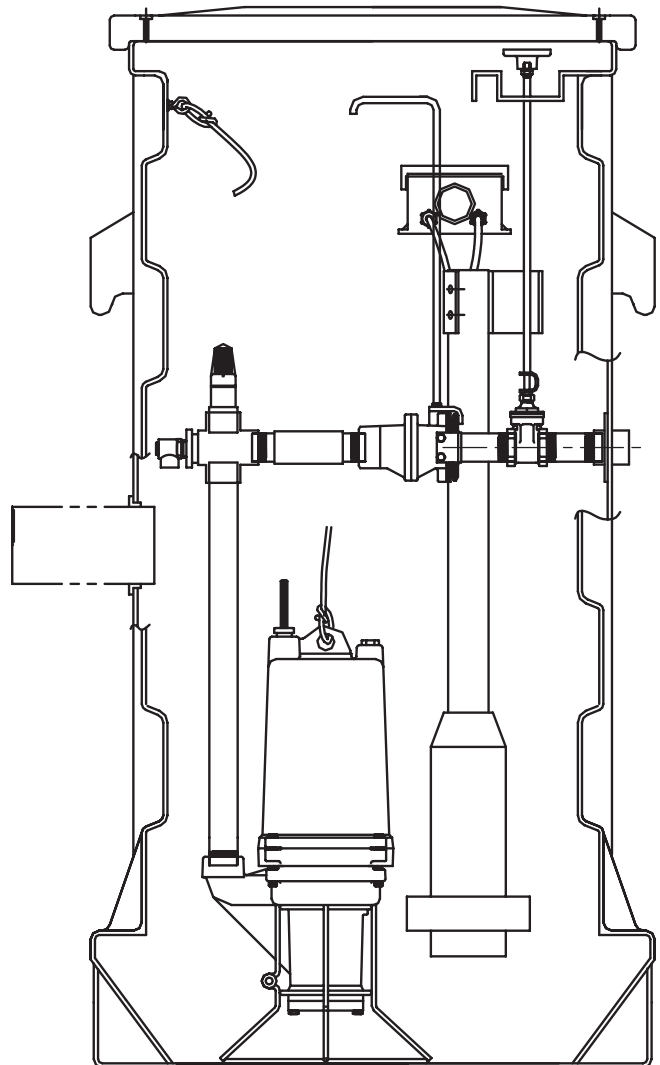

NOTE! To the installer: Please make sure you provide this manual to the owner of the pumping equipment or to the responsible party who maintains the system.

GENERAL INFORMATION

Thank you for purchasing your Low Pressure Sewer Basin System.

Before Installation:

This manual contains important information for the safe use of this product. Read this manual completely and follow the instructions carefully. Reasonable care and safe methods relating to the installation and operation of this product should be practiced. Check local codes and requirements before installation.

▲ DANGER

Risk of electrical shock or electrocution. May result in serious injury or death or fire hazard. Installer must disconnect all electrical sources prior to installation. Only qualified personnel may install this system. NFPA 70/National Electric Code (NEC) or local codes must be followed. System must be properly grounded according to NEC.

▲ DANGER

Biohazard Risk. Once wastewater source has been connected to system, Biohazard Risk exists. Installer(s) and/or service personnel must use proper Personal Protective Equipment and follow handling procedures per OSHA 29 CFR 1910.1030 when handling equipment after wastewater source has been connected to system.

▲ DANGER

Risk of fire or explosion. Do not smoke or use open flames in or around this system. This system is not intended for use in hazardous locations per NFPA 70 National Electric Code. Consult factory for optional equipment rated for this use.

▲ DANGER

Cutting Risk. Risk of serious cutting or amputation exists. Disconnect all power sources prior to servicing pump or grinding mechanism. Pump may start without warning. Grinding mechanism is extremely sharp. Use caution when handling grinder mechanism.

DO NOT THROW AWAY OR LOSE THIS MANUAL.

Keep it in a safe place so that you may refer to it often for the continued safe operation of the product.

▲ CAUTION

Delta Environmental Products does not recommend basins with base / bottom diameters greater than 30" when installing a simplex positive displacement pump (D1P20) system. When operational conditions require a basin with base/bottom diameter of greater than 30" it is necessary to perform a sludge pump out on the basin at least once per year to prevent any potential septic/odor conditions.

INSTALLATION SKILL REQUIREMENTS

The installation of a basin system is a specialized skill, which requires individuals with the basic understanding of excavating, pipe fitting, and electrical wiring.

These instructions are meant only to be an installation guide; therefore, unusual installation conditions not covered in these instructions require experienced personnel capable of utilizing reasonable engineering principles for the installation and operation of the system.

EXCAVATION INSTRUCTIONS

▲ DANGER

Excavation Location

Excavation location shall be made according to local codes and regulations. Check with local utility companies for the location of underground utilities prior to excavation. Care should be taken to avoid buried utility lines, piping, and other buried structures and foundations. Failure to follow these instructions may result in serious personal injury or death.

Excavation for Basin Systems:

Effect appropriate excavation based on size of the basin, desired entrance point of the influent line, and entrance of power connection.

BASIN INSTALLATION INSTRUCTIONS

▲CAUTION

If the basin is not tied down during installation, rain or flood conditions may cause the basin to float upward, causing damage to the basin or basin connections.

Basin System Handling:

Factory built basin systems must not be dropped, dragged, rolled, or handled with sharp objects. Improper handling of basins may result in damage to the basin, damage to basin components, or leaks in the piping assemblies.

Step 1

The pad under the basin, requires 4 to 6 inches of appropriate fill. The ideal basin pad is concrete in conjunction with anti-flotation tie-down studs. Basin anti-flotation tie-down kits are available from Delta Environmental Products. If concrete pad is not used, the aggregate must be compacted to a minimum 85% standard proctor density per ASTM D698, or as required by the **Authority Having Jurisdiction**. Concrete pad or aggregate surface must be leveled flat and free of voids to conform to the basin bottom. Basin bedding depth should be calculated such that the basin top will protrude 3" above the normal grade upon final installation.

Step 2

Lifting of the basin may be done with a nylon or other non-damaging type material sling. Do not wrap a chain or steel cable around the basin as damage may result. Do not attach lifting mechanism around discharge hub or electrical hub.

▲DANGER

Risk of electrical shock or electrocution. May result in serious injury or death or fire hazard. Failure to properly support electrical conduit, lines and connections may result in structural failure. Electrical connections may be damaged exposing live electrical connections.

Step 3

Lower the basin into excavation, position and level properly. Mount basin to base anchor bolts if an anti-flotation tie-down kit is used. If basin is fiberglass, inspect basin and seal off any cuts or scratches to prevent fiberglass deterioration.

INFLUENT AND DISCHARGE CONNECTION INSTRUCTIONS

Influent and Discharge Connections for Basins:

Step 1

An inlet grommet is the standard supplied influent connection device. If another type of inlet hub is used, refer to the directions included with the hub.

Determine point at which influent line will enter basin and, using a properly maintained piloted hole saw sized per chart below, drill a hole through the basin wall. If using a fiberglass basin, clean cut hole and apply a sealant coating to the cut section to prevent fiberglass deterioration. Insert the inlet grommet into the drilled hole.

Pipe Size	Hole Saw Diameter*
3"	4"
4"	5"
6" **	7"

*Contact factory for availability of proper sized hole saw if necessary.

** 6" pipe size requires use of fiberglass basin

▲ WARNING

Failure to use a properly piloted hole saw may result in damage to basin which may result in structural failure or serious leaks.

Step 2

Lubricate inside lip of inlet grommet with pipe soap. Clean outer end of influent pipe and push pipe through grommet. Ensure pipe does not protrude inside basin so as to interfere with pump removal or float operation.

Step 3

Close shut-off valve and make discharge line connection. It is strongly recommended that an additional shut-off valve and redundant check valve be located outside the basin at any force main entrances - check local codes for specific requirements.

BACKFILL INSTRUCTIONS

The Authority Having Jurisdiction has the right to require alternate materials or procedures for backfilling the installation.

▲ CAUTION

In freezing conditions the backfill must be dry and free of ice. Do not use other backfill materials. Failure to utilize the recommended bed and backfill materials during the installation of the basin voids the basin warranty.

▲ DANGER

Risk of electrical shock or electrocution.

May result in serious injury or death or fire hazard. Failure to properly support electrical conduit, lines and connections may result in structural failure. Electrical connections may be damaged exposing live electrical connections

Step 1

Obtain proper backfill material. The backfill material provides as much as 90% of the basin's support under certain stress conditions. The installer must be positive that correct bed and backfill materials are utilized per instructions as follows:

- A. Gravel-clean and free flowing with particle size not less than 1/8" nor more than 3/4" in diameter. Use this description when ordering or specifying as material varies upon geographical location. This material is commonly known as "pea gravel".
- B. Stone or gravel crushings with angular particle size of not less than 1/8" nor more than 1/2" diameter, washed and free flowing, is acceptable as an alternative material.

Step 2

At least a 4-6 inch wide band of compacted aggregate, must be placed in successive layers (6" lifts) around the entire periphery of the basin. Carefully compact aggregate under all piping and electrical lines. Cover grade should slope down 3" to the normal surrounding grade. Care must be taken to prevent damage to any influent, discharge, or electrical connections made to the basin.

FINAL BACKFILL FOR BASIN SYSTEMS

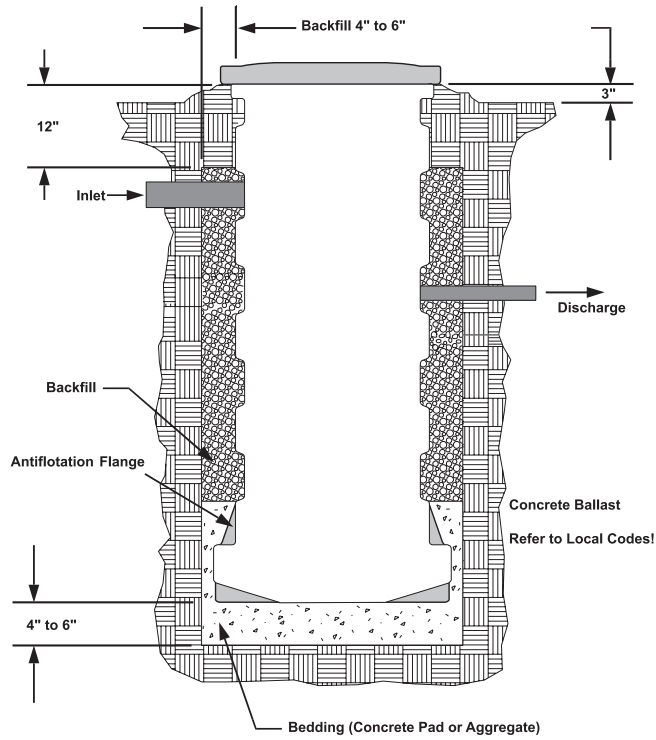

Polyethylene

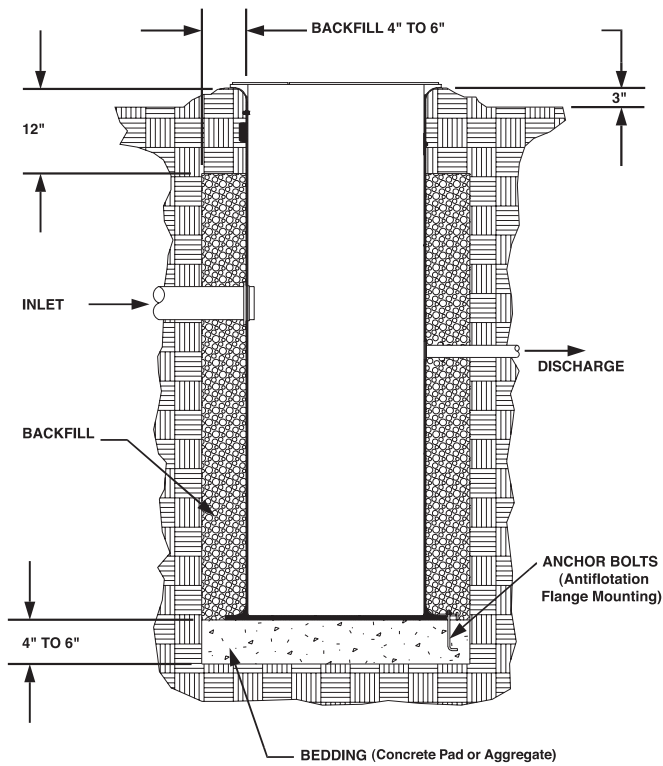

Fiberglass

INTERNAL BASIN INSTALLATION INSTRUCTIONS

▲ DANGER

Risk of electrical shock or electrocution. May result in serious injury or death or fire hazard. Installer must disconnect all electrical sources prior to installation. Only qualified personnel may install this system. NFPA 70/National Electric Code (NEC) or local codes must be followed. System must be properly grounded according to NEC or local codes.

▲ DANGER

Cutting Risk. Risk of serious cutting or amputation exists. Disconnect all power sources prior to handling or servicing pump or grinding mechanism. Pump may start without warning. Grinding mechanism is extremely sharp. Use caution when handling grinder mechanism.

Unpacking Pump:

Remove pump from carton. When unpacking unit, check for concealed damage. Claims for damage must be made at the receiving end through the delivery carrier. Damage cannot be processed from the factory.

Systems Description:

Factory built basin systems are available in 24" and 30" diameter basins with 60" through 156" depths in one foot increments. In a flex hose system, the pump is raised and lowered in the basin using rope or chain attached to pump and lifting handle attached to ball check valve. A hydraulic sealing diaphragm on ball check valve allows the pump to be removed without disconnecting piping.

Application:

These pump systems are designed for pumping effluent or sewage water with a pH ranging from 5 to 9, specific gravities from 0.9 to 1.1, viscosities ranging from 28 to 35 S.S.U. and temperatures up to 140°F.

▲ DANGER

Risk of fire or explosion. Do not smoke or use open flames in or around this system. This system is not intended for use in hazardous locations per NFPA/70 National Electric Code. Consult factory for optional equipment rated for this use.

Pump Models:

The basin system may employ any 2 HP submersible grinder pump which utilizes cutter blades to grind solids into a slurry. Refer to the pump service manual for the pump when adjusting, dismantling, or repairing the pump.

Inspection: Check to be sure that all items for your particular system are included, and that the phase and voltage on the pump nameplate are correct as ordered. Codes: All local codes must be observed. Consult the local inspector(s) before installation to avoid costly delays or rework.

Grinder Pump Attachments:

Step 1

Attach the stainless steel foot bracket to bottom of the pump with bolts and washers provided.

Apply Pipe:

Step 2

Apply thread sealant to pipe threads and screw the discharge piping assembly into the pump discharge.

Step 3

Attach lifting chain, cable or rope as supplied to the lifting eye bolts.

▲ DANGER

Risk of electrical shock or electrocution. May result in serious injury or death or fire hazard. To reduce risk of electrical shock, do not connect conduit to pump.

Internal Basin Connections:

Step 1

If the system is supplied with a float bracket, attach float switches to the float bracket by clamping strain relief bushings around the float cords, then inserting and twisting the bushings into the float bracket slots.

If the system is supplied with a pressure bell control unit, please refer to the separate manual regarding the pressure bell control unit

Step 2

After grinder pump attachments have been made, lower the pump unit down and ensure the ball check valve sealing flange aligns and connects properly with discharge.

INTERNAL BASIN INSTALLATION INSTRUCTIONS

Junction Box Systems:

Step 1

Ensure power source is off or disconnected.

Step 2

Push pump power, seal failure/heat sensor, and float cords through cord grips in the junction box and tighten. To prevent corrosion or electrical short, plug any unused holes.

Step 3

Remove junction box cover and make all connections inside junction box to all incoming control panel wires.

Step 4

It is recommended that the customer furnish and install a conduit seal outside the basin to prevent surface water from entering the junction box.

Electrical Connections:

▲ DANGER

Risk of electrical shock or electrocution. May result in serious injury or death or fire hazard. Installer must disconnect all electrical sources prior to installation. Only qualified personnel may install this system. NFPA 70/National Electric Code (NEC) or local codes must be followed. System must be properly grounded according to NEC or local codes.

NOTE: Failure to utilize a manufacturer approved control panel voids the pump warranty and guarantee.

▲ IMPORTANT: Properly connect the panel ground wire to a grounding rod. Improper grounding voids warranty.

Panel Wiring:

Step 1

Ensure power source is off or disconnected.

Step 2

Connect pump power, seal failure/ heat sensor, and float cords to panel terminals per the schematic provided. All conduits and cables entering the panel must be sealed off.

For single-phase pumps: Check panel wiring to ensure white, black, and red pump leads are connected according to the schematic and panel wire labels. Single phase pumps will only run if connected one way.

Three-phase pumps: Interchange any two line leads to the motor inside the panel if the pump rotates in the wrong direction.

▲ DANGER

Cutting Risk. Risk of serious cutting or amputation exists. Disconnect all power sources prior to handling or servicing pump or grinding mechanism. Pump may start without warning. Grinding mechanism is extremely sharp. Use caution when handling grinder mechanism.

Do not leave pump in basin unless it is placed in operation. If a pump has been out of service for an extended period of time, with the power off, rotate the impeller by turning the radial cutter with a screwdriver to be sure it rotates freely.

Electrical Connections:

D1C20 & D1P20

230 V, 1 Phase

Black	Common Power Line
White	Main Power Line
Green	Ground

D2C20

1 Phase

Green	Ground
Red	Start Power Line
White	Main Power Line
Black	Common Power Line
Orange	Seal Failure

Preoperational Grinder Pump Checks:

Step 1

Ensure power source is off or disconnected.

Step 2

Remove pump from basin.

Step 3

With power off, turn radial cutter with a screwdriver to be sure it rotates freely. If necessary to adjust, refer to pump service manual.

Step 4

Stand clear from pump and with power on, check for proper rotation of pump by turning "H-O-A" switch to "HAND" momentarily and then "OFF". The impeller should turn counterclockwise when viewed from the suction end.

PUMP OPERATIONS

Step 1

Run clear water into the basin until motor housing is covered.

Step 2

Open the shut-off valve to the discharge line.

Step 3

Turn “H-O-A” switch to the “OFF” position and turn on main breaker.

Step 4

Start the pump by turning the “H-O-A” switch to the “HAND” position.

Step 5

Check the pump amperage with clamp on ammeter on black pump lead. Readings higher than nameplate indicate clogged pump, miswiring, or improper voltage. If basin is not being pumped down and amperage readings are considerably lower than nameplate then the pump is air locked.

NOTE: Nameplate amperage is rated at the largest impeller diameter trim. Pumps with cut diameter impellers will draw slightly fewer amps than nameplate. If pump is air locked, refer to the troubleshooting section in this manual.

Step 6 (for float control systems only)

Float adjustment for simplex systems: Adjust floats so that the water level is above the pump motor housing, and the pump shuts off when the water level is 2 inches above the pump volute discharge.

Float adjustment for duplex systems: Adjust floats so that a pump will start when the water level is just above the pump motor housing, and pump on override water level is 5 inches above the pump motor housing. Adjust pump shut-off so that water level is within 2 inches above pump volute discharge. Pumps should alternate starting, between each other, upon successive pump down cycles. To check override level, set both “H-O-A” switches to “OFF” position and allow water to surpass the override level, then set both “H-O-A” switches to “AUTO” position and both pumps should start. Turn off one pump and be sure second pump starts when override level is reached on second trial. If pumps fail to cycle in this manner, retrace control float wiring panel.

Step 7

Ensure “H-O-A” switch is set to “AUTO” before placing system into service.

PUMP TROUBLESHOOTING

Below is a list of common problems and possible solutions. Refer to the pump and panel installation and service manuals for details regarding any necessary adjusting, dismantling or repair work.

▲ DANGER

Risk of electrical shock or electrocution. May result in serious injury or death or fire hazard. Installer must disconnect all electrical sources prior to installation. Only qualified personnel may install or service this system. NFPA 70/ National Electric Code (NEC) or local codes must be followed. System must be properly grounded according to NEC or local codes.

▲ DANGER

Cutting Risk. Risk of serious cutting or amputation exists. Disconnect all power sources prior to handling or servicing pump or grinding mechanism. Pump may start without warning. Grinding mechanism is extremely sharp. Use caution when handling grinder mechanism.

Pump Runs But Does Not Pump Down The Basin With The “H-O-A” Switch On Either Hand Or Automatic Position.

1. *Cutters may be clogged.* Amperage higher than nameplate may indicate this problem.
2. *Pump rotation may be reversed* (on three-phase pumps only). Switching any two power leads on three phase pumps will correct the rotation.
3. *Discharge gate valve may be closed.*
4. *Pump may be air locked.* Fill basin approximately 10 inches or more above the ball check valve assembly. Raise pump assembly so that the ball check valve disengages the discharge elbow (approximately 6 inches). Stand clear from the sump opening to avoid spray and turn pump on for a brief second to clear trapped air in the volute.
5. *Clogging anywhere from cutters to check valve.* This is evident if no water discharged out of the check valve after raising the pump to disconnect the sealing flange. Pull pump assembly and check for cause of clogging.
6. *Discharge head may be too high.* Check elevation against design point of pump.

7. *Clogging beyond the sealing flange.* This is evident if water is discharged through the check valve when raising the pump to disconnect the sealing flange. Inspect system basin piping or discharge piping from basin to locate clogging.

Basin Level Is Pumped Down With “H-O-A” On Switch Hand Position, But Is Not Pumped Down With “H-O-A” Switch On Automatic Position.

1. *Floats are not hanging free in the basin or are covered with grease.* Pump the level down with the “H-O-A” switch on “HAND”, so that the floats can be observed. Relocate and clean float(s) as necessary.
2. *If this is a new installation and original start-up, the floats may be miswired into the control panel.* If the on and off floats are reversed, the pump will short cycle on and off and will not pump the level down.
3. *Floats or alternator are malfunctioning.* Pull the floats out of the basin and hang the “OFF” and “ON” floats from your hand. Turn the “H-O-A” switch to “AUTO”. Tilt the “OFF” float so that the large end is above the cord end – nothing should happen. While keeping the “OFF” float tilted, tilt the “ON” float in the same manner – the pump should come on. Suspend the “ON” float again from your hand – the pump should continue to run. Finally, suspend the “OFF” float – the pump should stop running. If this procedure does not cause the pump to operate as described, either replace the float(s) or replace the alternator relay if the system is duplex.

Seal Failure Light Comes On.

1. *This indication means the lower seal has failed and has allowed water to enter the lower seal chamber to make contact with the electrode.* Pump must be scheduled for maintenance. Refer to the pump installation and service manual for information on replacing the lower seal.

NOTE: Use twisted shielded cable for seal failure cable runs in excess of 100 feet.

Pump Run Light Stays On.

1. *“H-O-A” switch may be in hand position.*
2. *Lower float may have failed causing the pump to continue operating below the “off” level.*
3. *Pump may be air locked.*
4. *Cutters may be clogged.*

Circuit Breaker Trips When Pump Tries To Start.

1. *Short circuit in pump motor.*
2. *Water may have entered the motor housing through either worn out mechanical seals or O-rings.*
3. *Contactors failure for three phase pumps.* Check pump contactor for burnt contacts.
4. *Start component(s) failure for single phase pumps.* Check start capacitor and start relay for failure.

5. *Single phase pump may be miss wired to panel.* The white, black, and red pump power leads must be connected correctly to panel.

Overload Trips, Is Manually Reset, And Then Trips Off Again.

1. *Cutters may be clogged.* It is possible that the pump stalled during operation, and starting and stopping cleared the cutters. If resetting the overloads solves this problem, return the “H-O-A” switch to “AUTO” and observe operation.
2. *Pump motor may have failed.*
3. *Start component(s) failure for single phase pumps.* Check start capacitor and start relay for failure.
4. *Single phase pump may be miss wired to panel.* The white, black, and red pump power leads must be connected correctly to panel.

TYPICAL INSTALLATIONS

Pump: D1P20
Switch: DFC
Type: Simplex

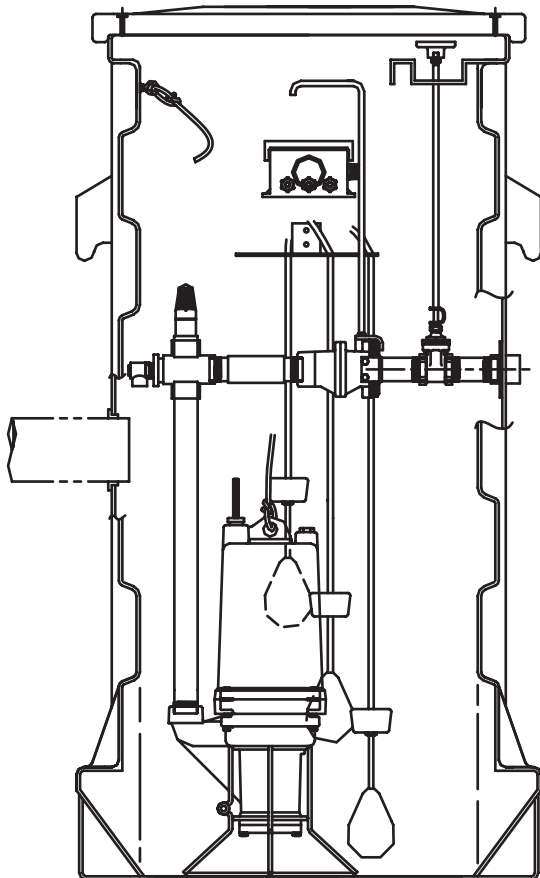
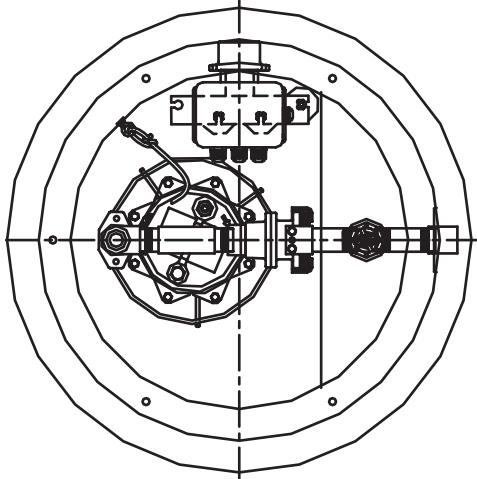

Pump: D1P20
Switch: DFC
Type: Duplex

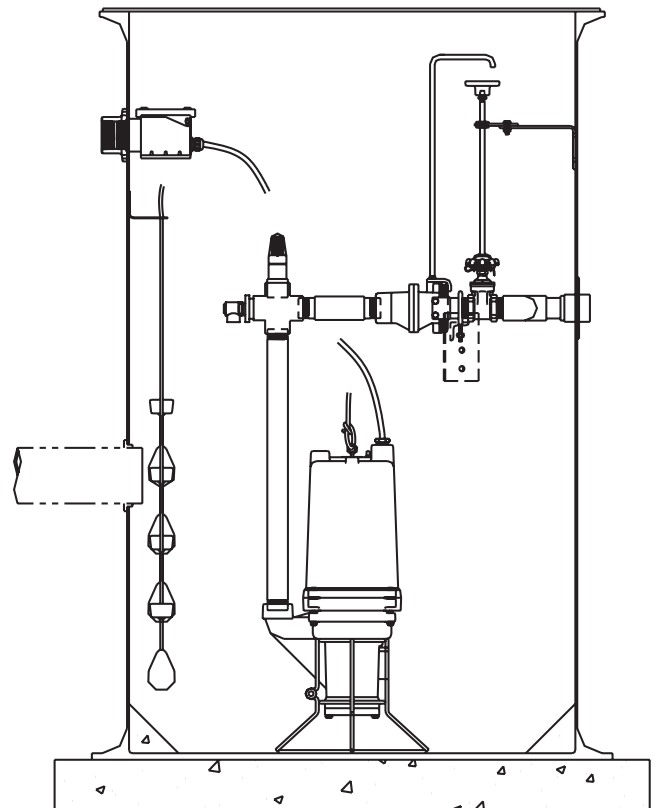
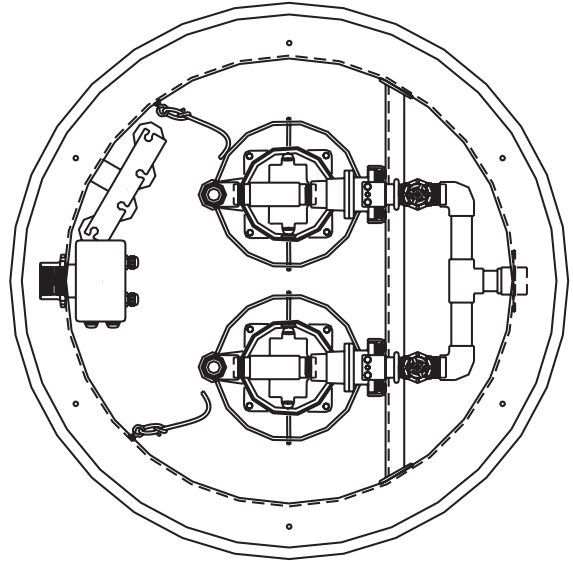

TYPICAL INSTALLATIONS

Pump: D1P20
Switch: DPC
Type: Simplex

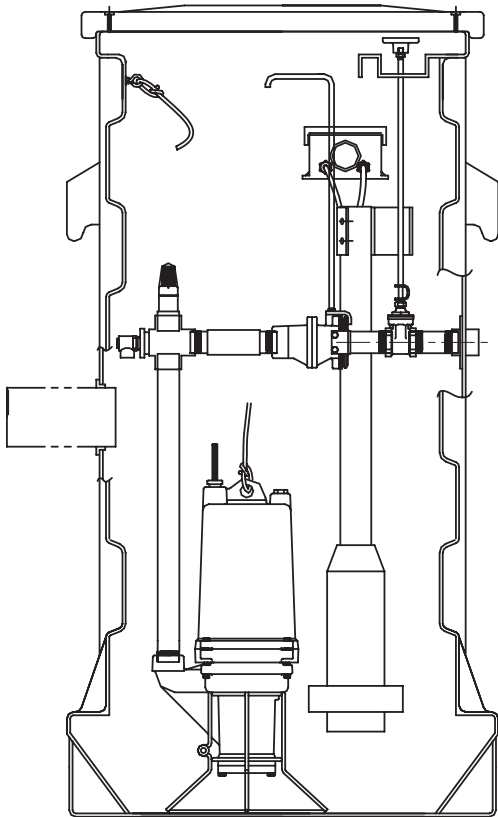
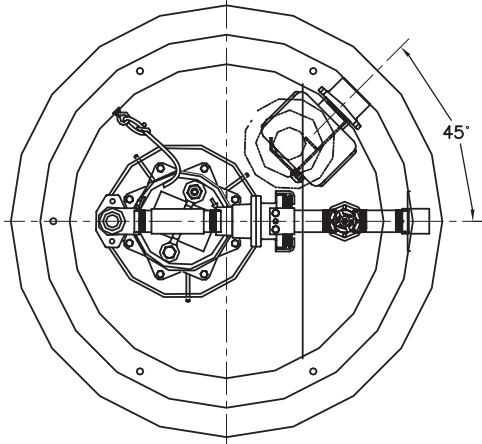

Pump: D1P20
Switch: DPC
Type: Duplex

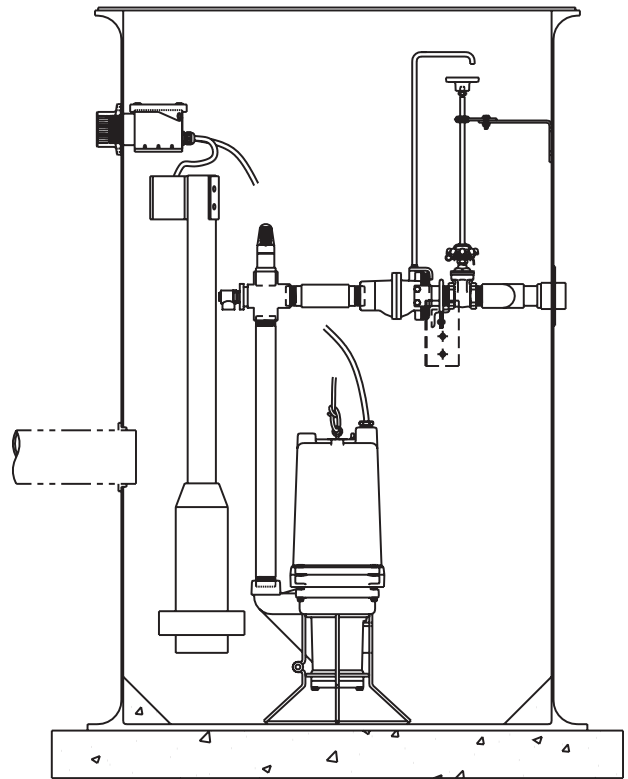
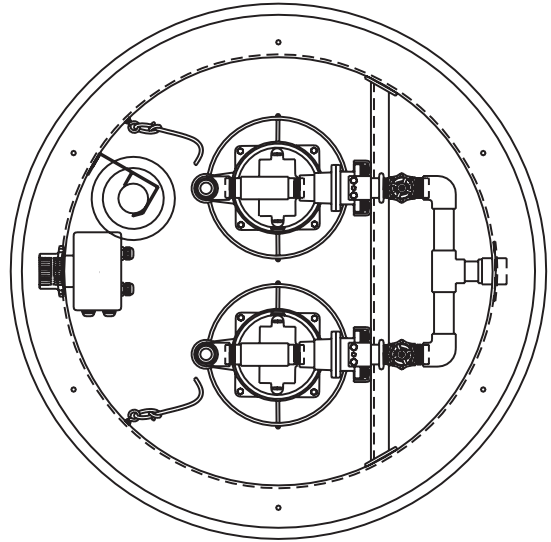

SIMPLEX SYSTEM PARTS LIST

No.	Part No.	Description	Qty.
1	21936D200	Cover - Sump 24" Plastic	1
1	27567A001	Cover - Sump 24" Poly	1
2	23901D301	Tank - FRP 24" x 60"	1
2	23901D304	Tank - FRP 24" x 72"	1
2	23901D306	Tank - FRP 24" x 84"	1
2	23901D308	Tank - FRP 24" x 96"	1
2	27570D001	Tank - Poly 24" x 60"	1
2	27570D002	Tank - Poly 24" x 72"	1
2	27570D003	Tank - Poly 24" x 84"	1
2	27570D004	Tank - Poly 24" x 96"	1
3	19101A010	Cap - Screw (plastic)	6
3	19099A033	Cap - Screw (poly)	6
4	001560321	Washer - Flat (plastic)	6
4	05030A138	Washer - Flat (poly)	6
5	097813264	Brace - Valve Stem	1
6	085373165	Handle - Extension 2'-0" Deep	1
6	085373015	Handle - Extension 3'-0" Deep	1
6	085373035	Handle - Extension 4'-0" Deep	1
6	085373055	Handle - Extension 5'-0" Deep	1
7	145340083	Handle - 24" Discharge Dep	1
7	145340013	Handle - 36" Discharge Dep	1
7	145340163	Handle - 48" Discharge Dep	1
7	145340173	Handle - 60" Discharge Dep	1
8	19109A018	Nut - Jam	1
9	24227B029	Hub - Tank Assy. 1-1/4"	1
10	24227B030	Plate - Backup	1
11	29019220450	Gasket	1
12	19101A017	Cap - Screw	4
13	19109A018	Hex - Nut	4
14	05454A015	Washer - Lock	4
15	063750635	Gate Valve Assembly	1
16	149130035	Discharge Piping Assembly	1
17	129610783	Pipe - 1-1/4" x 23-1/4" SST	1
17	129610913	Pipe - 1-1/4" x 27-5/8" SST	1
18	07947A020	Cross - 1-1/4" SST	1
18a	05004A122	Bushing - 1-1/4" x 1/2" PVC	1
18b	149850001	Valve - Relief	1
19	148790001	Valve - Anti-Siphon	1

No.	Part No.	Description	Qty.
20	05004A114	Bushing - 1-1/4" x 3/4" PVC	1
21	05008A059	Nipple - 3/4" Close, PVC	1
22	24335A001	4" Inlet Grommet	1
23	23971A012	Rope - Liftout, 15'	1
24	140841001	Hub - Junction Box 2" NPT	1
25	001760081	Cap - Screw	4
26	001120021	Hex - Nut	4
27	131070021	Washer - Sealing	4
28	128705011	Box - Junction Nema 6x	1
29	148870031	Stand - Wire	1
30	002380071	Cap - Screw	1
31	001560321	Washer-Flat	2
32	19109A018	Hex - Nut	1
33	27012B505	Bracket, SST for Pressure Bell	1
33	22470B005	Tree Bracket, SST for Floats	1
34	124330483	Pipe - 2" x 26-1/2"	1
34	124330493	Pipe - 2" x 38-1/2"	1
34	124330503	Pipe - 2" x 50-1/2"	1
34	06986A084	Pipe - 2" x 62-1/2"	1
35	27012B508	Tube - 50' Press.	1
36	27012B300	Pressure Bell	1
	21813A300K	Float Switches (not shown)	3
	14755A002	Float Bushings (not shown)	3

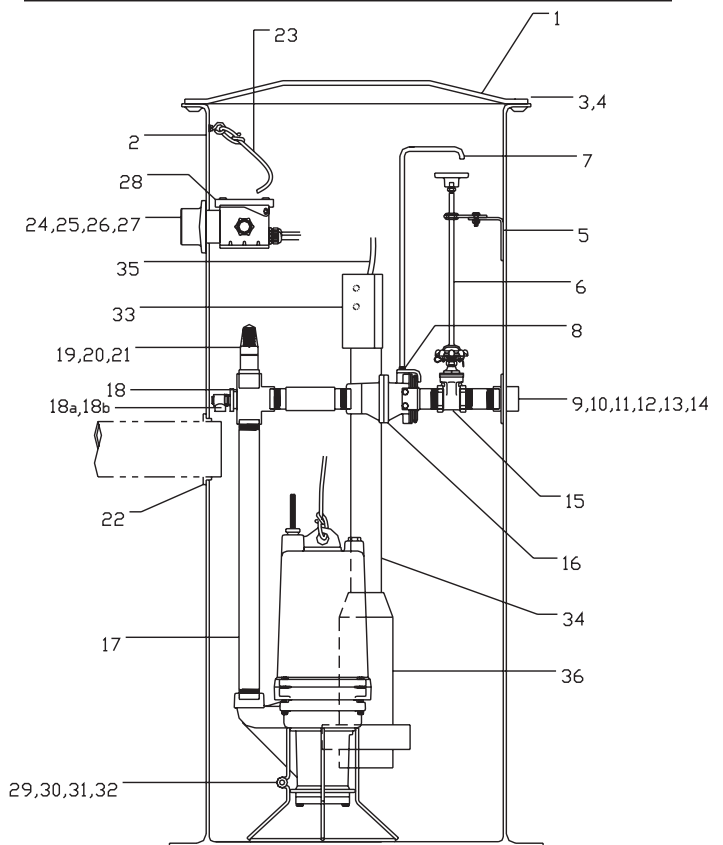

NOTE: Typical installation shown;
actual installation may vary

DUPLIX SYSTEM PARTS LIST

No.	Part No.	Description	Qty.
1	24951C036	Cover-Sump 36" Fiberglass	1
2	140020601	Tank - FRP 36" x 60"	1
2	140020721	Tank - FRP 36" x 72"	1
2	140020841	Tank - FRP 36" x 84"	1
2	140020961	Tank - FRP 36" x 96"	1
3	19101A010	Cap-Screw	6
4	001560321	Washer-Flat	6
5	097813065	Brace - Valve Stem	2
6	085373165	Handle - Extension 2'-0" Depth	2
6	085373015	Handle - Extension 3'-0" Depth	2
6	085373035	Handle - Extension 4'-0" Depth	2
7	145340083	Handle - Lifting 24" Disch. Depth	2
7	145340013	Handle - Lifting 36" Disch. Depth	2
7	145340163	Handle - Lifting 48" Disch. Depth	2
7	145340173	Handle - Lifting 60" Disch. Depth	2
8	19109A018	Nut - Jam	2
9	24227B026	Hub - Tank Assy. 1-1/4"	2
10	24227B030	Plate - Backup	2
11	29019220450	Gasket	2
12	19101A017	Cap-Screw	8
13	19109A018	Hex-Nut	8
14	05454A015	Washer-Lock	8
15	063750635	Gate Valve Assembly	2
16	149130035	Discharge Piping Assembly	2
17	129610783	Pipe - 1-1/4" x 23-1/4" SST	2
17	129610913	Pipe - 1-1/4" x 27-5/8" SST	2
18	07947A020	Cross - 1-1/4" SST	2
18a	05004A122	Bushing - 1-1/4" x 1/2" PVC	2
18b	149850001	Valve - Relief	2
19	148790001	Valve - Anti-Siphon	2
20	05004A114	Bushing - 1-1/4" x 3/4" PVC	2
21	05008A059	Nipple - 3/4" Close, PVC	2
22	24335A001	4" Inlet Grommet	1
23	23971A012	Rope - Liftout, 15'	2
24	140841001	Hub - Junction Box 2" NPT	1
25	001760081	Cap - Screw	4
26	001120021	Hex - Nut	4
27	131070021	Washer - Sealing	4
28	128705011	Box - Junction Nema 6x	1
29	148870031	Stand - Wire	2
30	002380071	Cap - Screw	4

No.	Part No.	Description	Qty.
31	001560321	Washer-Flat	8
32	19109A018	Hex - Nut	4
33	27012B505	Bracket, SST for Pressure Bell	1
33	22470B005	Tree Bracket, SST for Floats	1
34	124330483	Pipe - 2" x 26-1/2"	1
34	124330493	Pipe - 2" x 38-1/2"	1
34	124330503	Pipe - 2" x 50-1/2"	1
34	06986A084	Pipe - 2" x 62-1/2"	1
35	27012B508	Tube - 50' Press.	1
36	27012B300	Pressure Bell	1
37	143783365	Brace - Support, SST	1
38	063120011	Clamp - Muffler, SST	2
	21813A300K	Float Switches (not shown)	4
	14755A002	Float Bushings (not shown)	4

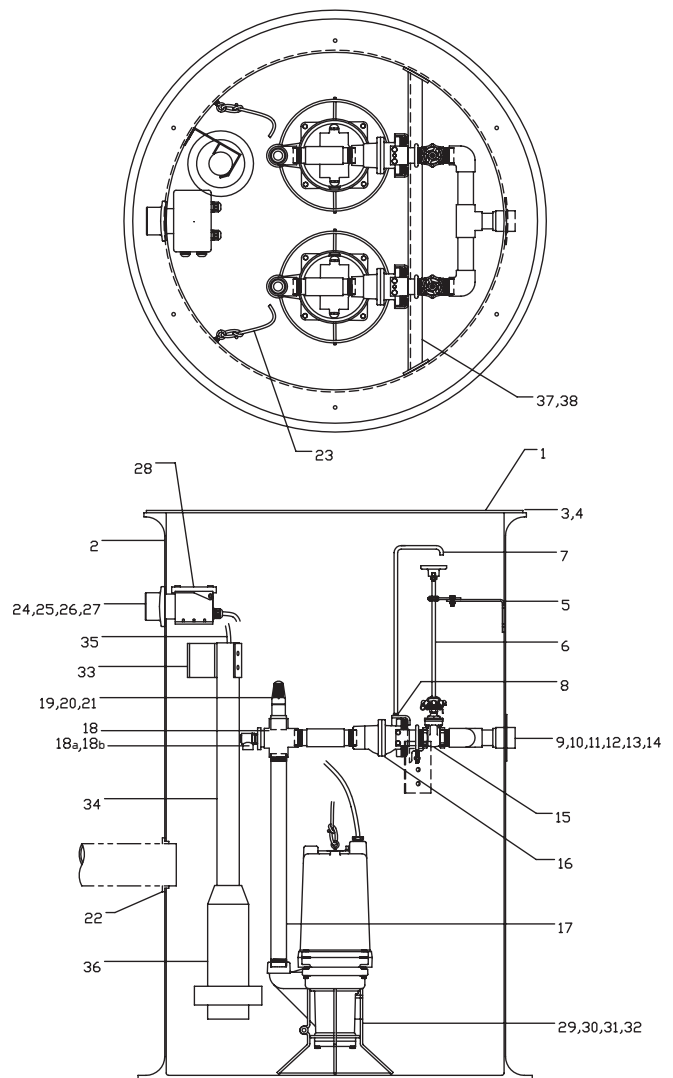

NOTE: Typical installation shown; actual installation may vary

STANDARD LIMITED WARRANTY

Delta warrants its products against defects in material and workmanship for a period of 12 months from the date of shipment from Delta or 18 months from the manufacturing date, whichever occurs first - provided that such products are used in compliance with the requirements of the Delta catalog and technical manuals for use in pumping raw sewage, municipal wastewater or similar, abrasive free non-corrosive liquids.

During the warranty period and subject to the conditions set forth, Delta, at its discretion, will repair or replace to the original user, the parts which prove defective in materials and workmanship. Delta reserves the right to change or improve its products or any portions thereof without being obligated to provide such a change or improvement for prior sold and/or shipped units.

Start-up reports and electrical schematics may be required to support warranty claims. Warranty is effective only if Delta authorized control panels are used. All seal fail and heat sensing devices must be hooked up, functional and monitored or this warranty will be void. Delta will only cover the lower seal and labor thereof for all dual seal pumps. Under no circumstance will Delta be responsible for the cost of field labor, travel expenses, rented equipment, removal/reinstallation costs or freight expenses to and from the factory or an authorized Delta service facility.

This limited warranty will not apply: (a) to defects or malfunctions resulting from failure to properly install, operate or maintain the unit in accordance with the printed instructions provided; (b) to failures resulting from abuse, accident or negligence; (c) to normal maintenance services and parts used in connection with such service; (d) to units which are not installed in accordance with applicable local codes, ordinances and good trade practices; (e) if the unit is moved from its original installation location; (f) if unit is used for purposes other than for what it is designed and manufactured; (g) to any unit which has been repaired or altered by anyone other than Delta or an authorized Delta service provider; (h) to any unit which has been repaired using non factory specified/OEM parts.

Warranty Exclusions: DELTA MAKES NO EXPRESS OR IMPLIED WARRANTIES WHICH EXTEND BEYOND THE DESCRIPTION ON THE FACE HEREOF. DELTA SPECIFICALLY DISCLAIMS THE IMPLIED WARRANTIES OF MERCHANTABILITY AND FITNESS FOR ANY PARTICULAR PURPOSE.

Liability Limitation: IN NO EVENT SHALL DELTA BE LIABLE OR RESPONSIBLE FOR CONSEQUENTIAL, INCIDENTAL OR SPECIAL DAMAGES RESULTING FROM OR RELATED IN ANY MANNER TO ANY DELTA PRODUCT OR PARTS THEREOF. PERSONAL INJURY AND/OR PROPERTY DAMAGE MAY RESULT FROM IMPROPER INSTALLATION. DELTA DISCLAIMS ALL LIABILITY, INCLUDING LIABILITY UNDER THIS WARRANTY, FOR IMPROPER INSTALLATION. DELTA RECOMMENDS INSTALLATION BY PROFESSIONALS.

Some states do not permit some or all of the above warranty limitations or the exclusion or limitation of incidental or consequential damages and therefore such limitations may not apply to you. No warranties or representations at any time made by any representatives of Delta shall vary or expand the provision hereof.



Pentair Water
1101 Myers Parkway
Ashland, Ohio 44805-1969
419-289-1144
www.delta.com