

# Service Manual



ORDER NO.  
ARP 1465

FM/AM DIGITAL SYNTHESIZER TUNER

# F-91

# Original

MODEL F-91 COMES IN FIVE VERSIONS DISTINGUISHED AS FOLLOWS:

Type	Power requirement	Export destination
KU/CA	AC120V only	U.S.A and Canada
HE	AC220V, 240V (switchable) *	European continent
HB	AC220V, 240V (switchable) *	United Kingdom
SD/G	AC110V, 120V-127V, 220V, 240V (switchable)	U.S.Military
HEZ	AC220V, 240V (switchable) *	West Germany

\* Change the primary wiring of the power transformer.

- This service manual is applicable to the KU/CA, HE, HB, SD/G and HEZ types.
- As to the HE, HB, SD/G and HEZ types, please refer to pages P39-P40.
- Ce manuel pour le service comprend les explications en français de réglage. (P28-P29)
- Este manual de servicio trata del método ajuste escrito en español. (P30-P31)

## CONTENTS

1. SPECIFICATIONS.....	2	8. PACKING .....	32
2. PANEL FACILITIES.....	3	9. IC INFORMATION.....	33
3. EXPLODED VIEW AND PARTS LIST.....	5	10. BLOCK DIAGRAM .....	35
4. SCHEMATIC DIAGRAM .....	9	11. CIRCUIT DESCRIPTION .....	37
5. P.C. BOARDS CONNECTION DIAGRAM .....	13	12. FOR HE, HB, HEZ AND SD/G TYPES.....	39
6. ELECTRICAL PARTS LIST .....	22		
7. ADJUSTMENTS .....	26		
RÉGLAGE .....	28		
AJUSTE.....	30		

# 1. SPECIFICATIONS

## FM Tuner Section

Frequency range	87.5 MHz to 108 MHz
Usable Sensitivity	Mono; 9.8 dBf, IHF (0.85 $\mu$ V/75 $\Omega$ )
50 dB Quieting Sensitivity	
U.S. and Canadian models	
Mono; 12.8 dBf, IHF (1.2 $\mu$ V/75 $\Omega$ )	
Stereo; 34.8 dBf, IHF (15 $\mu$ V/75 $\Omega$ )	
U.K. and other destination's models	
Mono; 15.3 dBf, IHF (1.6 $\mu$ V/75 $\Omega$ )	
Stereo; 35.9 dBf, IHF (17 $\mu$ V/75 $\Omega$ )	
Sensitivity (DIN)	Mono; 0.75 $\mu$ V/75 $\Omega$
	Stereo; 20 $\mu$ V/75 $\Omega$
Signal-to-Noise Ratio	
U.S. and Canadian models	
Mono; 95 dB (at 80 dBf)	
Stereo; 88 dB (at 80 dBf)	
U.K. and other destination's models	
Mono; 95 dB (at 80 dBf)	
Stereo; 87 dB (at 80 dBf)	
Signal-to-Noise Ratio (DIN)	Mono; 77 dB
	Stereo; 73 dB
Distortion (at 80 dBf)	Mono; 0.015% (100 Hz)
	0.009% (1 kHz)
	0.02% (10 kHz)
	Stereo; 0.02% (100 Hz)
	0.02% (1 kHz)
	0.07% (10 kHz)
Capture Ratio	0.8 dB
Alternate Channel Selectivity	85 dB (400 kHz)
Stereo Separation	65 dB (1 kHz)
	55 dB (20 Hz to 10 kHz)
Frequency Response	+0.2 dB (20 Hz to 15 kHz)
	-0.8
Image Response Ratio	70 dB
IF Response Ratio	100 dB
AM Suppression Ratio	70 dB
Spurious Response Ratio	80 dB
Subcarrier Product Ratio	60 dB
Muting Threshold	25.2 dBf (5 $\mu$ V/75 $\Omega$ )
Antenna Input	75 unbalanced

## AM Tuner Section

Frequency range	531 kHz to 1602 kHz (Step 9 kHz)
	530 kHz to 1700 kHz (Step 10 kHz)
Sensitivity (IHF, Loop antenna)	150 $\mu$ V/m
Selectivity	40 dB
Signal-to-Noise Ratio	50 dB
Image Response Ratio	40 dB
IF Response Ratio	60 dB
Antenna	Loop Antenna

## Audio Section

Output (Level/Impedance)	
FM (100% MOD) FIXED	650 mV/0.9 k $\Omega$
AM (30% MOD) FIXED	150 mV/0.9 k $\Omega$

## Miscellaneous

Power Requirements	
U.S. and Canadian models	AC120V, 60 Hz
U.K. model	a.c.240V, 50/60 Hz
Other destination's models	
AC110V/120-127V/220V/240V (switchable), 50/60 Hz	
Power Consumption	25W
Dimensions	457 (W) x 85 (H) x 316 (D) mm
	18 (W) x 3-3/8 (H) x 12 - 7/16 (D) in
Weight (without package)	5.2 kg (11 lb 8 oz)

## Furnished Parts

FM T-type Antenna	1
AM Loop Antenna	1
Connecting Cord with Pin Plugs	1
Antenna adaptor *	1
Control cord *	1
Operating Instructions	1

\* Not attached on U.K. model.

### NOTE:

Specifications and design subject to possible modification without notice due to improvements.

## 2. PANEL FACILITIES

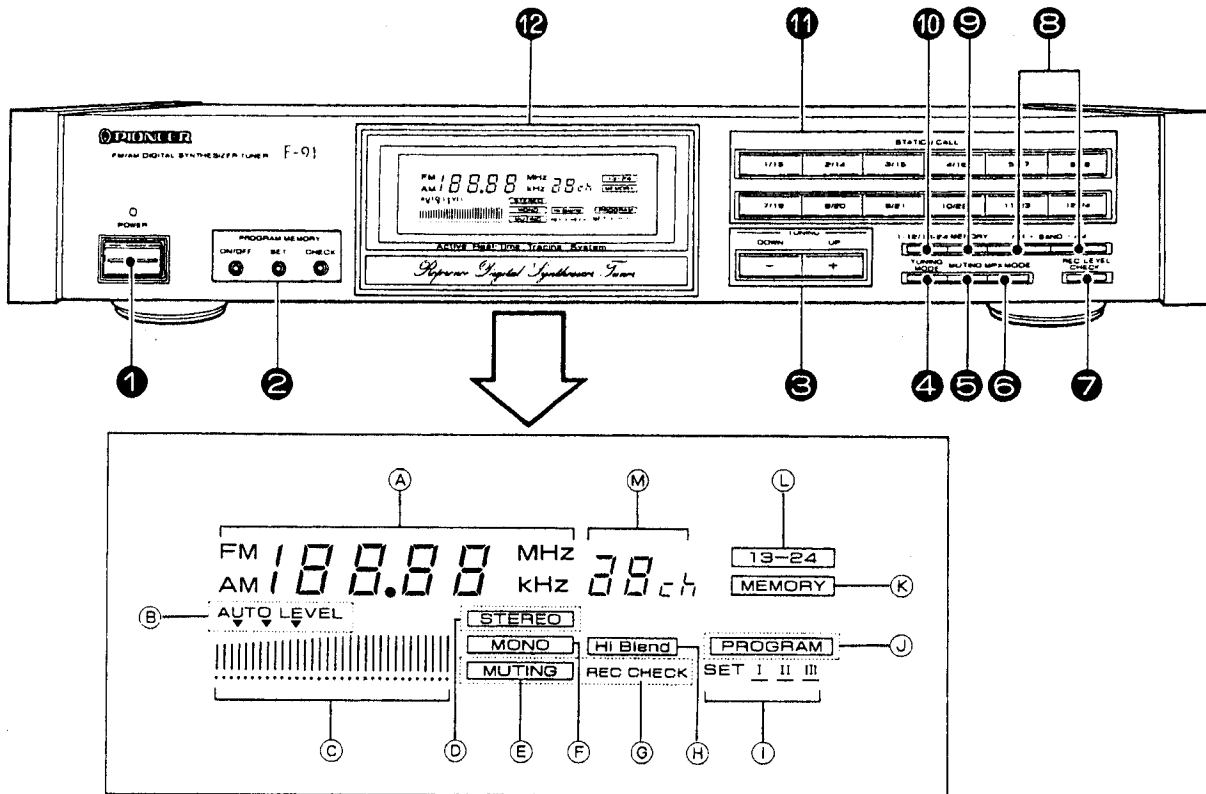

### 1 POWER switch/Indicator

- Press to turn power on . . . . on
- Press again to turn power off . . . . off

### 2 PROGRAM MEMORY buttons

Convenient for programmed recording.

#### ON/OFF:

Set to ON, and the three memorized stations will be recalled in sequence as power is turned off and on again.

#### SET:

Press to set the program memory contents.

#### CHECK:

Press to confirm the program memory contents.

### 3 TUNING UP/DOWN switches

Use these switches to tune in broadcasting stations. Press UP (+) to receive a station whose frequency is higher than the displayed frequency, and DOWN (-) to tune in to a lower frequency station.

### 4 TUNING MODE switch

To select the tuning mode. It changes each time the switch is pressed:

#### MANUAL:

Frequency changes by one step each time one of the TUNING UP/DOWN switches is pressed. When the switch is held depressed the frequency will change continuously.

— [ ▼ ] AUTO LEVEL indicator off

#### AUTO 1:

Press one of the TUNING UP/DOWN switches once. The unit will automatically scan the frequency band and stop when it finds a station (a too weak signal station will be ignored). In this case use MANUAL tuning mode.

— [ ▼ ] AUTO LEVEL indicator lights up

#### AUTO 2:

Tuning will stop at stations with more than medium signal strength.

— [ ▼ ] AUTO LEVEL indicator lights up

#### AUTO 3:

Tuning will only stop at strong signal stations.

— [ ▼ ] AUTO LEVEL indicator lights up

**5 MUTING switch**

The muting circuit is designed to remove the typical FM interstation noise generated when moving away from in-tune frequencies, but it can also prevent reception of distant or weak signal stations. In this case, press the MUTING switch off and tune into the desired station. Normally, leave this switch on (MUTING indicators lit).  
This switch does not affect AM reception.

**NOTE:**  
The setting of this switch is memorized together with the station in the station memory.

**6 MPX (multiplex) MODE switch**

Mode changes as follows each time this switch is pressed:

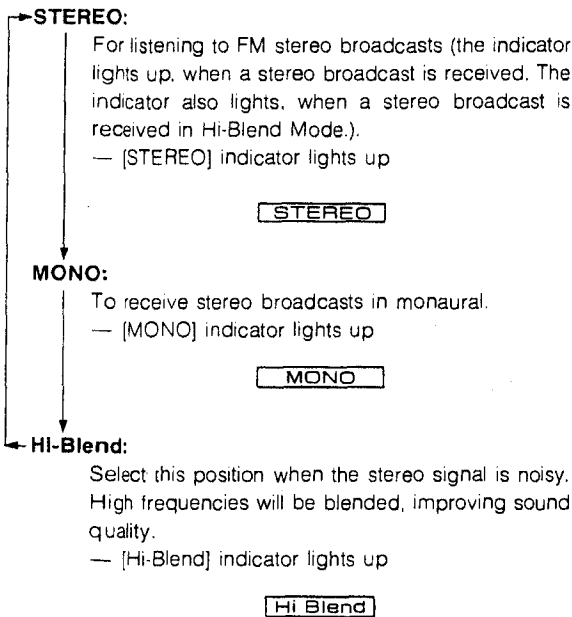

**NOTE:**  
The setting of this switch is memorized together with the station in the station memory.

**7 REC LEVEL CHECK switch**

To set the tape deck recording level when recording FM broadcasts. Press this switch on (the REC CHECK indicator will start flashing), and an FM recording standard level signal (frequency: approx. 330 Hz; level: equivalent to 50% modulation FM) will be continuously delivered from the OUTPUT jacks. Adjust the tape deck level meter reading to approx. -2 dB to obtain an appropriate recording level. Always press this switch off after setting the recording level (the REC CHECK indicator will go off).

**8 BAND selector switches**

**FM:**  
Press to receive FM broadcasts.

**AM:**  
Press to receive AM broadcasts.

**9 MEMORY switch**

Press to memorize preset stations. The [MEMORY] indicator will remain lit for about 5 seconds. Press the desired STATION CALL switch to memorize it during this period.

MEMORY

**10 [1-12/13-24] Station call selector switch**

Use this selector to choose between channels 1-12 and 13-24 when memorizing station frequencies or recalling already stored stations. The [13-24] indicator lights up when channels 13-24 are selected.

13-24

**11 STATION CALL switches**

Use these switches to preset stations and to receive already preset stations.

**12 Operation Display**

- (A) Shows reception band and frequency.
- (B) When the TUNING MODE switch is set to AUTO 1-3, the mark ▼ above the signal indicator indicates the level set for automatic tuning.
- (C) Signal indicator
- (D) Lights up when a stereo broadcast is received.
- (E) Stays lit while muting is occurring.
- (F) Stays lit while the MPX MODE switch is set to MONO.
- (G) Flashes when the REC LEVEL CHECK switch is set to on.
- (H) Stays lit while the MPX MODE switch is set to Hi-Blend.
- (I) Shows the condition of the program memory mode.
- (J) Stays lit while the PROGRAM MEMORY ON/OFF switch is on.
- (K) Lights for about 5 seconds when the MEMORY switch is pressed.
- (L) Lights up when the station call selector switch is set to 13-24.
- (M) When a STATION CALL switch is pressed, it will show the corresponding channel number.



### 3. EXPLODED VIEW AND PARTS LIST

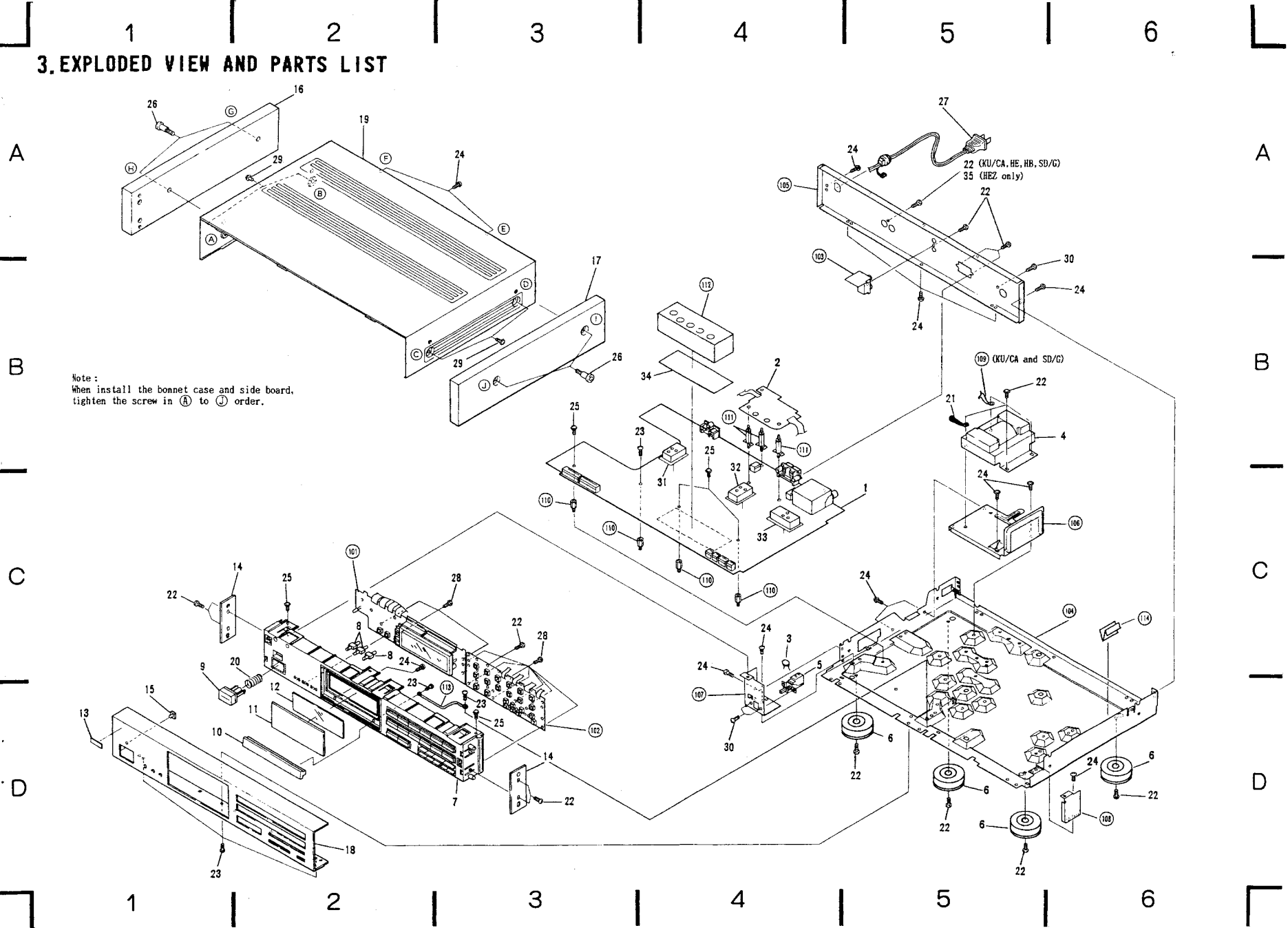

Note:  
When install the bonnet case and side board,  
tighten the screw in (A) to (J) order.

#### Parts Li

- △
- △★
- △★★

#### Extern

- RN1
- RN2



NOTES:

- Parts without part number cannot be supplied.
- The  $\Delta$  mark found on some component parts indicates the importance of the safety factor of the part. Therefore, when replacing, be sure to use parts of identical designation.
- For your parts Stock Control, the fast moving items are indicated with the marks \*\* and \*.
- \*\* GENERALLY MOVES FASTER THAN \*
- This classification shall be adjusted by each distributor because it depends on model number, temperature, humidity, etc.
- Parts marked by \* $\odot$  are not always kept in stock. Their delivery time may be longer than usual or they may be unavailable.

Parts List

Mark	No.	Part no.	Description	Mark	No.	Part no.	Description
	1	AWZ1568	TUNER assembly		25	ABA1011	Screw
	2	AWZ1570	AM assembly		26	ABA1032	Screw
$\Delta$	3	ACF-501	Ceramic capacitor (0.01 $\mu$ F/AC250V, C409)	$\Delta$	27	ADG-088	AC power cord
$\Delta$ *	4	ATT1043	Power transformer (T901)		28	BBZ26P080FMC	Screw
$\Delta$ **	5	ASG-541	Push switch (POWER, S901)		29	FBT40P060FZK	Screw
	6	AMR1047	Leg assembly		30	VHZ30P060FCU	Screw
	7	AMB1222	Panel base assembly		31	AWZ1576	DET VCO assembly
	8	AAD1190	Tact knob B (PROGRAM MEMORY)		32	AWZ1577	IF VCO assembly
	9	AAD1197	Power knob (POWER)		33	AWZ1580	FRONT END OSC assembly
	10	AAN1029	Aluminum sash		34	AWZ1579	IF MODULE assembly
	11	AAK1298	Acrylic panel		35	ABA1035	Screw (HEZ only)
	12	AAK1300	FL filter		101		FL assembly
	13	AAM1001	Name plate		102		SW assembly
	14	AAP1064	Side sash		103		REMOCON assembly
	15	AMR1160	LED lens		104		Chassis
	16	AMS1015	Side board L		105		Rear panel
	17	AMS1016	Side board R		106		Transformer frame
	18	ANB1128	Front panel		107		Front panel holder A
	19	ANE1087	Bonnet case		108		Front panel holder B
	20	ABH1033	Coil spring A		109		Earth lead
	21	ABC-093	Binder		110		PCB holder
	22	ABA-298	Screw		111		PCB support
	23	ABA1006	Screw		112		Shield cover
	24	ABA1009	Screw		113		Earth lead
					114		Earth leader

External Appearance of Transistor and ICs

RN1203  
RN2201

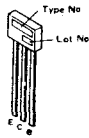

ZSC2603  
ZSA1115

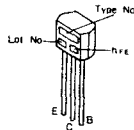

ZSK241  
ZSK161

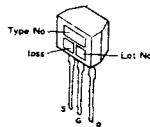

ZSJ103  
ZSK246

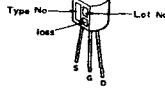

P001

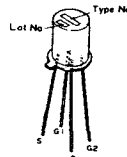

CX-7925B

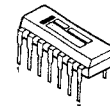

PD5056

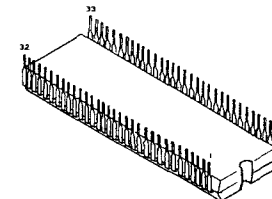

ZSB560

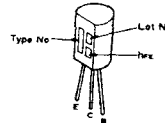

ZSB834

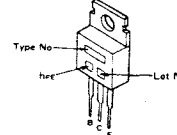

ZSC2389

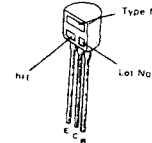

ZSC2668

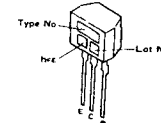

ZSC2786

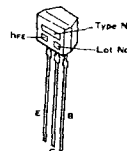

ZSC2878

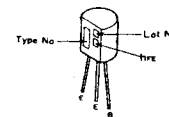

LC7570

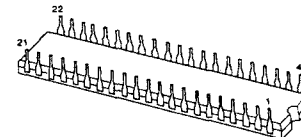

MS218P

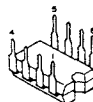

$\mu$  PC1163H



$\mu$  PC78M05H

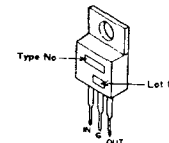

LA1247

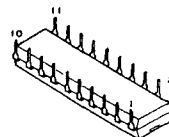

NJM1496D

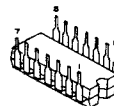

PA5008

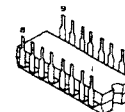

PA5007

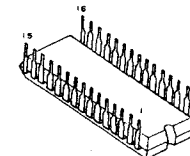









4 | 5 | 6 | 7 | 8 | 9

(A) AN21556 (HEZ)  
(B) AN21559 (SD7G)

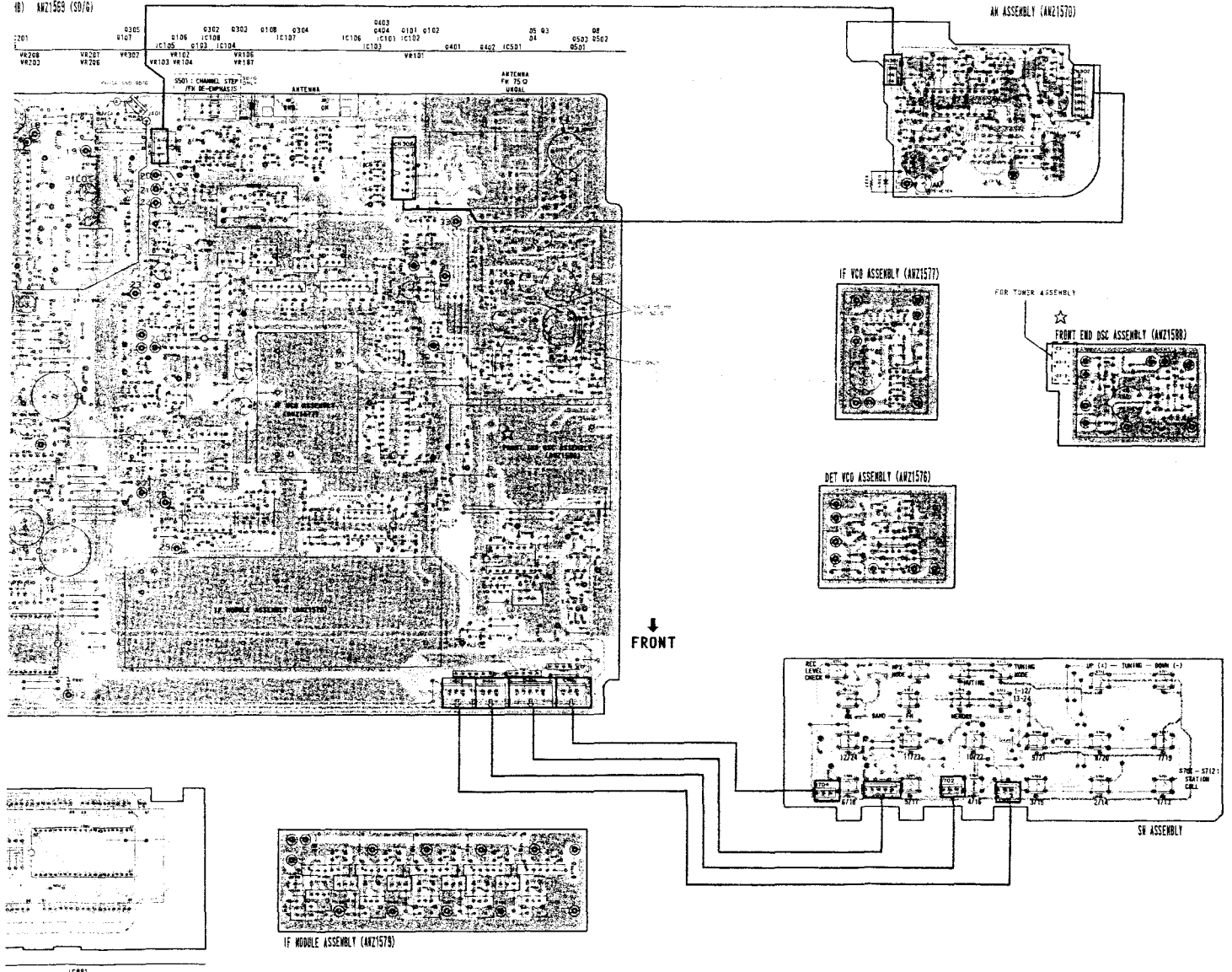

Note: D3-4 in the FRONT END OSC ASSEMBLY and D3-1 to D3-3 in the TUNER ASSEMBLY are used the even characteristic varactor. Therefore, when the FRONT END OSC ASSEMBLY is replaced, replace D3-1 to D3-3 in the TUNER ASSEMBLY together. Use D3-1 to D3-3 so that D3-1 to D3-3 as even characteristic as D3-4 are installed in the FRONT END OSC ASSEMBLY.

- NOTE
1. This P.C.B. connection diagram is viewed from the parts mounted side.
  2. The parts which have been mounted on the board can be replaced with those shown with the corresponding wiring symbols listed in the following Table.

P.C.B. pattern diagram indication	Corresponding part symbol	Part Name
		Transistor
		Radiator type transistor
		Diode
		Resistor
		Capacitor (Polarity)
		Capacitor (Non-polarity)

Others

P.C.B. pattern diagram indication	Part Name
IC	IC
S	Switch
RY	Relay
L	Coil
F	Filter
VR	Variable resistor or Semi-fixed resistor

3. The capacitor terminal marked with ⊕ (double circles) shows negative terminal.
4. The diode terminal marked with ⊕ (double circles) shows cathode side.
5. The transistor terminal to which E is affixed shows the emitter.

A

B

C

D

4 | 5 | 6 | 7 | 8 | 9

(31) 20215NA (40)  
(31) 20215NA (40)

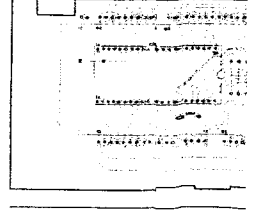
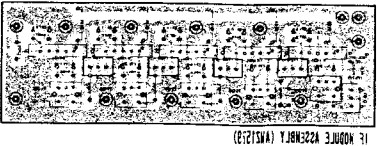
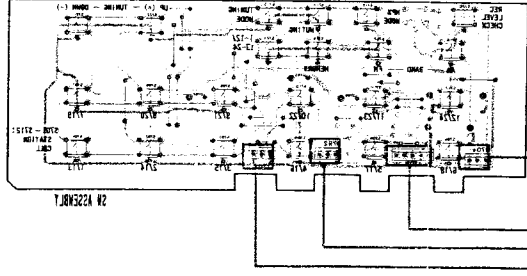
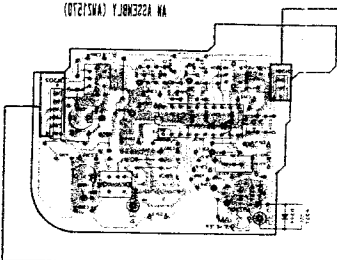
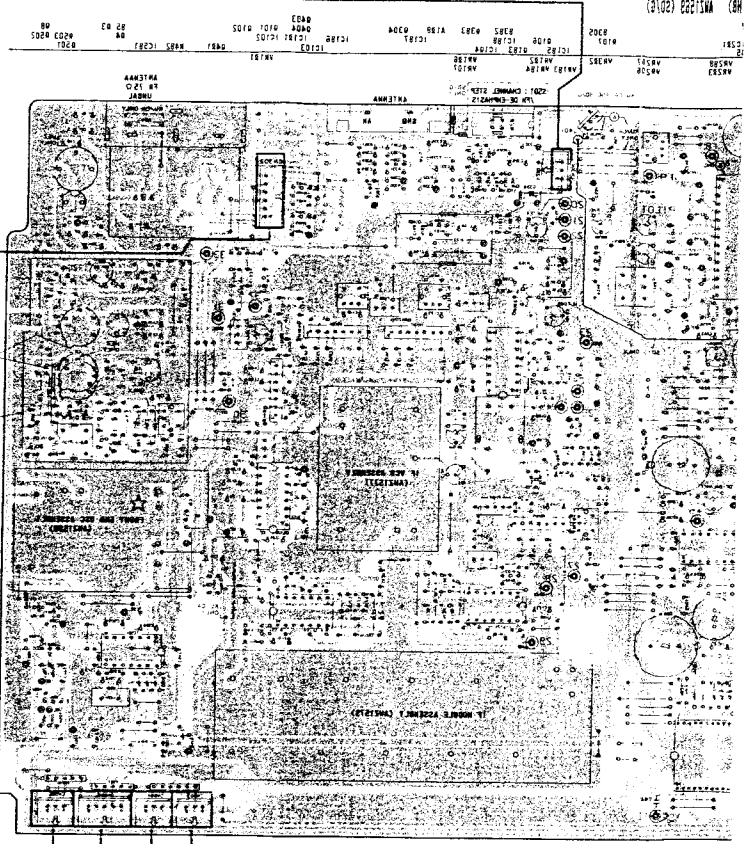

NOTE:  
Use 02-1 to 02-3 on Plat 02-1 to 02-3 as even characteristics as 02-4 are recalled in the FRONT END OPT. ASSEMBLY.  
Use 02-1 to 02-3 on Plat 02-1 to 02-3 as even characteristics as 02-4 are recalled in the FRONT END OPT. ASSEMBLY.  
Use 02-1 to 02-3 on Plat 02-1 to 02-3 as even characteristics as 02-4 are recalled in the FRONT END OPT. ASSEMBLY.  
Use 02-1 to 02-3 on Plat 02-1 to 02-3 as even characteristics as 02-4 are recalled in the FRONT END OPT. ASSEMBLY.

NOTE:  
1. This P.C.B. connection diagram is viewed from the rear mounted side.  
2. The parts which have been mounted on the board can be replaced with those shown.  
3. The corresponding wiring symbols are listed in the following T lists.

Part Name	Corresponding Part Symbol	P.C.B. Part Name
Transistor		IC
Resistor (film)		S
Diode		RY
Resistor		F
Capacitor (Polysty)		R
Capacitor (Non-poly)		V

Part Name	P.C.B. Part Name
Variable Resistor	V
Resistor	R
Cap	F
Relay	RY
Switch	S
IC	IC

1. The transistor terminals marked with (R) should be connected to the positive terminal.  
2. The diode terminals marked with (C) should be connected to the positive terminal.  
3. The capacitor terminals marked with (N) should be connected to the positive terminal.

A

B

C

D



## 6. ELECTRICAL PARTS LIST

**NOTES:**

- Parts without part number cannot be supplied.
- Parts marked by "⊙" are not always kept in stock. Their delivery time may be longer than usual or they may be unavailable.
- The Δ mark found on some component parts indicates the importance of the safety factor of the part. Therefore, when replacing, be sure to use parts of identical designation.
- For your parts Stock Control, the fast moving items are indicated with the marks ★★ and ★.
- ★★ **GENERALLY MOVES FASTER THAN ★**  
This classification shall be adjusted by each distributor because it depends on model number, temperature, humidity, etc.
- When ordering resistors, first convert resistance values into code form as shown in the following examples.  
Ex.1 When there are 2 effective digits (any digit apart from 0), such as 560 ohm and 47k ohm (tolerance is shown by J=5%, and K=10%).  
560Ω 56×10<sup>1</sup> 561 ..... RD1/4PS510J  
47kΩ 47×10<sup>3</sup> 473 ..... RD1/4PS50J  
0.5Ω 085 ..... RN2H0085K  
1Ω 010 ..... RS1P0010K  
Ex.2 When there are 3 effective digits (such as in high precision metal film resistors).  
5.62kΩ 562×10<sup>1</sup> 5621 ..... RN1/4SR5621J

**Miscellaneous Parts**

Mark	Symbol & Description	Part No.
	REMOCON assembly	
	FL assembly	
	TUNER assembly	AWZ1568
	SW assembly	
	AM assembly	AWZ1570
	DET VCO assembly	AWZ1576
	IF VCO assembly	AWZ1577
	FRONT END OSC assembly	AWZ1580
	IF MODULE assembly	AWZ1579
Δ	C409 Ceramic capacitor (0.01/AC250V)	ACE-501
	L901 Loop antenna assembly	ATB-086
Δ ★	T901 Power transformer	ATT1043
Δ ★★	S901 Push switch (POWER)	ASG-541
Δ	AC power cord	ADG-088

**REMOCON Assembly**

Mark	Symbol & Description	Part No.
★★	0603	RN1203
★★	060J, 060Z	2SC2603
★	0601	1SS131

**RESISTORS**

Mark	Symbol & Description	Part No.
	R601-R604	RD1/8PM103J

**OTHERS**

Mark	Symbol & Description	Part No.
	2P Mini jack (CONTROL)	AKN-209

**FL Assembly**

Mark	Symbol & Description	Part No.
★★	IC801, IC802	LC7570
★★	Q801-Q809	RN2201
★	D801 LED (POWER)	AEL-451
★	D802-D813	1SS131

**SWITCHES**

Mark	Symbol & Description	Part No.
★★	S801-S803 Tact switch (PROGRAM MEMORY (CHECK, SET, ON/OFF))	ASG-711

**RESISTORS**

Mark	Symbol & Description	Part No.
	R801	RD1/4PM221J
	R802-R811	RD1/8PM□□□□J

**OTHERS**

Mark	Symbol & Description	Part No.
★	V801 Fluorescent indicator tube	AAV1025

**TUNER Assembly (ANZ1568)  
SEMICONDUCTORS**

Mark	Symbol & Description	Part No.
★★	TH101, TH201 Thermistor	TH103-2
★★	IC501	CX-7925B
★★	IC203	M5218P
★★	IC103, IC104	NJM1496D
★★	IC202	PA5007
★★	IC102, IC108, IC201	PA5008
★★	IC502	PD5056
★★	IC101, IC105-IC107	μPC1163H
★★	IC401	μPC78M05H
★★	Q3	P001
★★	Q101, Q105, Q402, Q404, Q412	RN1203
★★	Q102, Q104	RN2201
★★	Q403, Q501	2SA1115
★★	Q401	2SB560
★★	Q406, Q409	2SB834
★★	Q205	2SC2389
★★	Q302-Q304, Q407, Q408, Q410, Q411, Q502	2SC2603
★★	Q103	2SC2668
★★	Q4, Q5	2SC2786
★★	Q106, Q107, Q202, Q203	2SC2878
★★	Q201	2SJ103
★★	Q8, Q108	2SK241
★★	Q204, Q209, Q305, Q405, Q503	2SK246
★	D411	HZSGC2L
★	D409, D410, D416	HZS9A3L
★	D408	RD13EB
★	D407	RD15EB
★	D418	RD2, 2ESB
★	D5	RD7, 5EB
★	D419	RD8, 2ESB
★	Q203, Q204	RD8, 2FB
★	D412-D415, D417, D506	SS566
★	D4, D201, D202, D302, D303, D501-D505, D507, D508	1SS131
★	D101, D102	1SS85
★	D401-D406	10DF2FD
★	D103, D104	2-1K261

**COILS, FILTERS  
AND TRANSFORMERS**

Mark	Symbol & Description	Part No.
	L2 FM RF Coil	ATC-205
	L1 FM ANT Coil	ATC-244
	L501 Inductor (1mH)	ATM-098
	L203 Coil (38kHz)	ATM-026
	L204 Coil (19kHz)	ATM-028
	L105, L107 Axial inductor	LAU010M
	L102, L104, L106, L108, L115-L117, L123, L124, L201, L205 Axial inductor	LAU2R2M
	L101, L111, L114, L121 Axial inductor	LAU221K

Mark	Symbol & Description	Part No.	Mark	Sy
	L103, L109, L110, L122	LAU389K		C5
	Axial inductor			C5
	L112 Inductor	LTA223J		C1
	L113 Inductor	LTA472J		C2
	F101 FM Ceramic filter	ATF-118		C1
				C4
	F103, F104 FM IF filter	ATF-139		C1
	F105, F106 Ceramic filter	ATF1024		C4
	F102 FM IF filter	ATF1025		C5
	T1 FM RF transformer	ATC-204		C2
	T3 FM Balun transformer	ATC-218		C1
				C1
	T104 FM Matching transformer	ATE-063		C4
	T2 FM IF transformer	ATE-066		C4
	T103 FM Detector transformer	ATE-068		C1
	T101, T102	ATE1004		C2
				C2

**CAPACITORS**

Mark	Symbol & Description	Part No.	Mark	Sy
	TC1-TC3 Trimmer	ACM-018		C24
	C244 (390p/DC50V)	ACG-023		C2
	C1-C5, C9, C11, C13, C14, C21, C22, C28, C37-C39, C101, C104, C127, C130, C137, C145, C168, C169, C184, C190, C191, C201, C267, C268 (0.01/DC25V)	ACG-036		C40
				C20
				C17
				C40
				C21
	C18, C27, C102, C103, C105, C106, C108, C120, C121, C123, C124, C128, C129, C131, C134-C136, C138-C144, C162, C163, C165-C167, C170, C171, C173-C175, C177, C188, C202-C204, C209, C211, C220, C231, C250, C251 (0.047/DC25V)	ACG-037		C22
				C15
				C32
				C23
				C32
				C41
				C41
				C33
				C50
				C22
				C23
				C15
				C15
				C21
				C22
				C16
				C22
				C24
				C24
				C26
				C26
				C26

**TUNER Assembly (AWZ1568)**

**SEMI CONDUCTORS**

Mark	Symbol & Description	Part No.
★★	TH101, TH201 Thermistor	TH103-2
★★	IC501	CX-7925B
★★	IC203	M5218P
★★	IC103, IC104	NJM1496D
★★	IC202	PA5007
★★	IC102, IC108, IC201	PA5008
★★	IC502	PD5056
★★	IC101, IC105-IC107	μPC1163H
★★	IC401	μPC178M05H
★★	Q3	P001
★★	Q101, Q105, Q402, Q404, Q412	RN1203
★★	Q102, Q104	RN2201
★★	Q403, Q501	2SA1115
★★	Q401	2SB560
★★	Q406, Q409	2SB834
★★	Q205	2SC2389
★★	Q302-Q304, Q407, Q408, Q410, Q411, Q502	2SC2603
★★	Q103	2SC2668
★★	Q4, Q5	2SC2786
★★	Q106, Q107, Q202, Q203	2SC2878
★★	Q201	2SJ103
★★	Q8, Q108	2SK241
★★	Q204, Q209, Q305, Q405, Q503	2SK246
★	Q411	HZSGC2L
★	D409, D410, D416	HZS9A3L
★	D408	RD13EB
★	D407	RD15EB
★	D418	RD2, 2ESB
★	D5	RD7, 5EB
★	D419	RD8, 2ESB
★	D203, D204	RD8, 2FB
★	D412-D415, D417, D506	SS566
★	D4, D201, D202, D302, D303, D501-D505, D507, D508	1SS131
★	D101, D102	1SS85
★	D401-D406	100F2FD
★	D103, D104	2-1K261

**COILS, FILTERS AND TRANSFORMERS**

Mark	Symbol & Description	Part No.
	L2 FM RF Coil	ATC-205
	L1 FM ANT Coil	ATC-244
	L501 Inductor (1μH)	ATH-038
	L203 Coil (38kHz)	ATH-026
	L204 Coil (19kHz)	ATH-028
	L105, L107 Axial inductor	LAU010M
	L102, L104, L106, L108, L115-L117, L123, L124, L201, L205 Axial inductor	LAU2R2M
	L101, L111, L114, L121 Axial inductor	LAU221K

Mark	Symbol & Description	Part No.
	L103, L109, L110, L122 Axial inductor	LAU3R9K
	L112 Inductor	LTA223J
	L113 Inductor	LTA472J
	F101 FM Ceramic filter	ATF-118
	F103, F104 FM IF filter	ATF-139
	F105, F106 Ceramic filter	ATF1024
	F102 FM IF filter	ATF1025
	T1 FM RF transformer	ATC-204
	T3 FM Balun transformer	ATC-218
	T104 FM Matching transformer	ATE-063
	T2 FM IF transformer	ATE-066
	T103 FM Detector transformer	ATE-068
	T101, T102 FM Matching transformer	ATE1004

**CAPACITORS**

Mark	Symbol & Description	Part No.
	TC1-TC3 Trimmer	ACH-018
	C244 (390p/DC50V)	ACC-023
	C1-C5, C9, C11, C13, C14, C21, C22, C28, C37-C39, C101, C104, C127, C130, C137, C145, C168, C169, C184, C190, C191, C201 C267, C268 (0.01/DC25V)	ACC-036
	C18, C27, C102, C103, C105, C106, C108, C120, C121, C123, C124, C128, C129, C131, C134-C136, C138-C144, C162, C163, C165-C167, C170, C171, C173-C175, C177, C188, C202-C204, C209, C211, C220, C231, C250, C261 (0.047/DC25V)	ACC-037
	C518 (47000μ/5.5V)	ACH101J
	C185	CCCSL010C50
	C186	CCCSL030C50
	C187	CCCSL050C50
	C132, C269, C419, C521	CCCSL101J50
	C182, C183	CCCSL181J50
	C160	CCCSL221J50
	C126	CCCSL271J50
	C133	CCCSL390J50
	C12	CCDCH010C50
	C23, C24	CCDCH030C50
	C508, C513	CCDCH150J50
	C512	CCDCH220J50
	C519, C520	CCDCH270J50
	C8	CCDCH470J50
	C25, C26	CCDRH101J50
	C6, C7	CCDSH050C50
	C15, C16, C19, C20	CCDSH150J50
	C333	CCDSL101J50
	C17	CCDSL820J50

Mark	Symbol & Description	Part No.
	C501	CEANL2R2M50
	C502	CEASR47M50
	C179, C192, C206, C332	CEASO10M50
	C243	CEASIR5M50
	C159, C242, C246, C247, C416, C418, C514	CEAS100M50
	C125, C511	CEAS101M10
	C414, C415	CEAS101M16
	C504	CEAS101M35
	C214, C249, C330, C421, C505	CEAS220M25
	C122	CEAS221M16
	C410, C411	CEAS222M16
	G402	CEAS322M35
	C181, C334, C336, C408, C420	CEAS477M50
	C262	CEAS470M10
	C212, C401, C412, C413	CEAS470M25
	C245	CEAS688M50
	C251	CEXA222M16
	C404	CEXA471M50
	C217, C218	CEYANP3R3M50
	C189	CEYA101M16
	C406, C407	CEYA101M50
	C205, C260	CEYA102M16
	C176	CEYA221M16
	C403	CEYA221M50
	C210, C219	CEYA222M16
	C221, C222, C234, C235, C237, C238	CEYA477M50
	C225, C226	CPTXA103J50
	C156	CPTXA104J50
	C327-C329	CPTXA123J50
	C325	CPTXA223J50
	C236	CFTXA333J50
	C326	CFTXA473J50
	C208, C509	CIDWF102Z50
	G44, C178, C180, C335, C506	CKDYF103Z50
	C417	CKDYF223Z50
	C331, C405, C507, C510, C515, C516	CKDYF473Z50
	C503	QAMX103J100
	C223, C224	QAMX102J100
	C232, C233	QAMX182J100
	C158	QAMXA202J100
	C157	QAMXA222J100
	C215, C216	QAMXA242J100
	C227, C228	QAMXA272J100
	C161	QAMXA362J100
	C229, C230	QAMXA472J100
	C248	QBSA682J50
	C241	QBSA821J50
	C263, C264	QBSXA331J160
	C239, C240	QBSXA561J160

**RESISTORS**

Mark	Symbol & Description	Part No.
★	VR106, VR202 Semi-fixed (1kΩ)	VRTS6VS102
★	VR103, VR204, VR205 Semi-fixed (10kΩ)	VRTS6VS103
★	VR102, VR104, VR201 Semi-fixed (100kΩ)	VRTS6VS104
★	VR101, VR203 Semi-fixed (220Ω)	VRTS6VS221
★	VR107, VR206 Semi-fixed (2.2kΩ)	VRTS6VS222
★	VR207 Semi-fixed (22kΩ)	VRTS6VS223
★	VR208, VR209 Semi-fixed (220kΩ)	VRTS6VS224
★	VR302 Semi-fixed (47kΩ)	VRTS6VS473
	R408 Carbon composition resistor (2.2M/1/2W)	AGN-209
	R527, R528 Resistor array (10k×4)	RA4S103J
	R526 Resistor array (10k×5)	RA5S103J
	R206, R207, R210-R213, R216-R235, R237, R238, R240-R243, R258, R261	RDR1/4PM□□□J
	R34, R250, R401	RDI/2PM□□□J
	R11, R20, R236	RDI/4PM□□□J
	R208, R209, R214, R215, R248, R403, R404	RNI/4PM□□□□F
	R420, R421	RS1LMF181J
	R409, R422	RS2LMF□□□□J
	Other resistors	RDI/8PM□□□□J

**OTHERS**

Mark	Symbol & Description	Part No.
★	X502 Ceramic resonator	ASS-030
★	X501 Crystal resonator 2P Pin jack (OUTPUT) 2P Push terminal	ASS1009 AKN1031 AKE-060

**SM Assembly SEMI CONDUCTORS**

Mark	Symbol & Description	Part No.
★	D702, D703, D705-D708, D710	1SS131

**SWITCHES**

Mark	Symbol & Description	Part No.
★★	S701-S718, S720-S723 Tact switch	ASG-711
	[STATION CALL, TUNING (UP, DOWN), 1-12/13-24 MEMORY, BAND (FM, AM), TUNING MODE, MUTING, MPX MODE, REC LEVEL CHECK]	

**AM Assembly (AWZ1570)**

**SEMICONDUCTORS**

Mark	Symbol & Description	Part No.
★★	IC301	LA1247
★★	Q301	2SK246
★	D301	KV1226
★	D304, D305	1SS131
★	D306	RD5.1ESB
★	D307	HZS5CLL

**COIL, FILTER AND TRANSFORMERS**

Mark	Symbol & Description	Part No.
	L301 AM OSC Coil	ATB-073
	F301 AM Ceramic filter	ATF1004
	T301 AM Antenna transformer	ATB-087
	T302 AM IF transformer	ATB1002

**CAPACITORS**

Mark	Symbol & Description	Part No.
	TC301	ACM-019
	TC302	ACM-020
	C304	CCDUJ100D50
	C309	CEAS010M50
	C306	CEAS100M50
	C317, C320	CEAS330M16
	C311, C312	CEAS4R7M50
	C323	CFTXA103J50
	C324	CFTXA473J50
	C316, C318	CKDYF102Z50
	C307, C308, C313, C315, C321	CKDYF103Z50
	C310, C322	CKDYF223Z50
	C302, C314, C319	CKDYF473Z50
	C305	CQSA431K50
	C333	CCDSL101J50

**RESISTORS**

Mark	Symbol & Description	Part No.
★	VR301 Semi-fixed (22kΩ)	VRTS6VS223
	Other resistors	RD1/8PM□□□J

**OTHERS**

Mark	Symbol & Description	Part No.
★	X301 Ceramic resonator	ATF-125

**DET VCO ASSEMBLY (AWZ1576)**

**IF VCO ASSEMBLY (AWZ1577)**

**★FRONT END OSC ASSEMBLY (AWZ1580)**

**IF MODULE ASSEMBLY (AWZ1579)**

There are not supplied parts above four assemblies.

**☆Note:**

D3-4 in the FRONT END OSC ASSEMBLY and D3-1 to D3-3 in the TUNER ASSEMBLY are used the even characteristic varactor. Therefore, when the FRONT END OSC ASSEMBLY is replaced, replace D3 -1 to D3-3 in the TUNER ASSEMBLY together. Use D3-1 to D3-3 so that D3-1 to D3-3 as even characteristic as D3 -4 are installed in the FRONT END OSC ASSEMBLY.

## 7. ADJUSTMENTS

### AM Section Adjustments

- Wire as shown in Fig. 7-1
- Set the AM key to ON and the REC LEVEL CHECK key to OFF.

Step	AM SG (400Hz, 30% de modulation)		F-91 frequency indication	Adjustment point	Adjustments
	Frequency	Level			Standard
1	No signal		530kHz (531kHz)* <sup>1</sup>	L301	Adjust so that the voltage between terminal 33 and ground is 2V ( $\pm 0.3V$ ).
2			1,700kHz (1,602kHz)* <sup>1</sup>	TC301	Adjust so that the voltage between terminal 33 and ground is 24.5V ( $\pm 0.5V$ ).
3	Repeat steps 1 and 2 until both ground voltage standards are satisfied.				
4	Mechanically set VR301 to the midpoint.				
5	600kHz (603kHz)* <sup>1</sup>	50 - 80dB	600kHz (603kHz)* <sup>1</sup>	T301	Maximize the voltage between terminal 35 and ground.
6	1,400kHz (1,395kHz)* <sup>1</sup>	50 - 80dB	1,400kHz (1,395kHz)* <sup>1</sup>	TC302	
7	Repeat steps 5 and 6 until the maximum voltage standard is satisfied in both steps.				
8	600kHz (603kHz)* <sup>1</sup>	100dB	600kHz (603kHz)* <sup>1</sup>	VR301	Adjust so that the voltage between terminal 35 and ground is 4.9V ( $\pm 0.1V$ ). <sup>*2</sup>

- \*1: The frequency in the parenthesis is the frequency at 9kHz STEP (HE and HB types).
- \*2: Do not let the voltage of terminal 35 exceed 5.2V.

### FM Section Adjustment

Note: The adjustment method of this FM section is simple throughout.

- Wire as shown in Fig. 7-2
- Set the FM key to ON, and the REC LEVEL CHECK and MUTING keys to OFF.

Step	FM SG (1kHz, $\pm 75kHz$ deviation)		F-91 frequency indication	Adjustment point	Adjustments
	Frequency	Level			Standard
1	No signal		108MHz	L3	Adjust so that the voltage between terminal 33 and ground is 23.5V ( $\pm 0.2V$ ).
2			87.5MHz	...	Confirm that the voltage between terminal 33 and ground is 7.5V ( $\pm 1.0V$ ).
3	90MHz	40dB	90MHz	L1, T1, L2	Maximize the voltage between terminal 22 and ground.
4	106MHz	40dB	106MHz	TC1-3	
5	Repeat steps 3 and 4 until both ground voltage standards are satisfied. Terminate the adjustment with step 4.				
6	106MHz	60dB	106MHz	T103-a	Set the voltage to 0V for terminal 24 to 26.
7	98MHz	1dB (Stereo modulation)*	98MHz	VR103	Adjust to the point just before muting is applied.
8	98MHz	40dB	98MHz	-	Check the output level of the output terminal.
9	Set the REC LEVEL CHECK key to ON.			VR302	At step 8, set the output level of the output terminal to -6dB ( $\pm 1dB$ ).

\* Stereo modulation: Main 1kHz, L-R,  $\pm 68.25kHz$  dev. pilot 19kHz,  $\pm 6.75kHz$  dev.



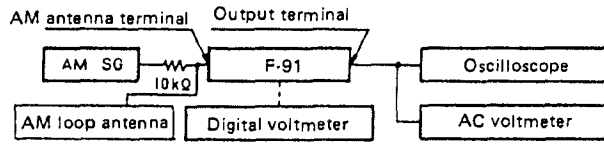

Fig. 7-1 AM adjustment wiring diagram

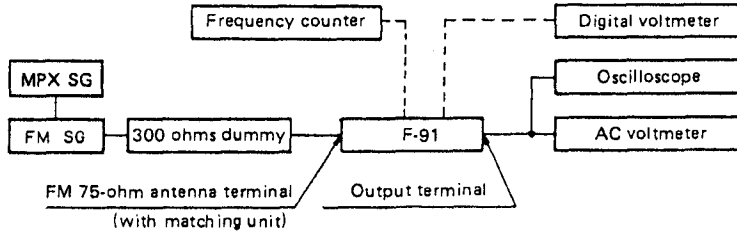

Fig. 7-2 FM adjustment wiring diagram

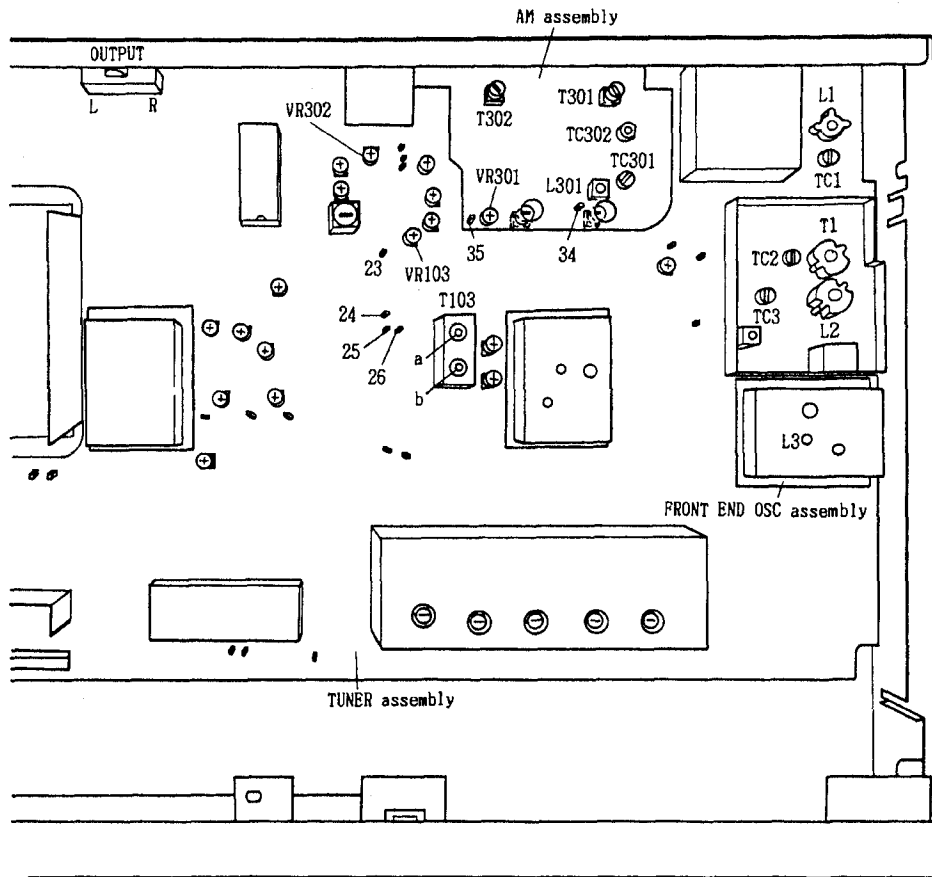

Fig. 7-3 Adjustment point

## 7. RÉGLAGE

### Réglages de la Section AM

- Effectuer le câblage comme indiqué sur la figure 7-1.
- Enclencher la touche AM et désenclencher la touche REC LEVEL CHECK.

Etape	AM SG (400Hz, 30% de modulation)		F-91 indication de fréquence	Point de réglage	Réglages
	Fréquence	Niveau			Norme
1	Aucun signal		530kHz (531kHz) <sup>*1</sup>	L301	Régler de telle manière que la tension entre la borne 33 et la terre soit égale à 2V ( $\pm 0,3V$ ).
2			1.700kHz (1.602kHz) <sup>*1</sup>	TC 301	Régler de telle manière que la tension entre la borne 33 et la terre soit égale à 24,5V ( $\pm 0,5V$ ).
3	Répéter les étapes 1 et 2 jusqu'à ce que les deux normes de tension de terre soient satisfaites.				
4	Régler mécaniquement VR301 à mi-chemin.				
5	600kHz (603kHz) <sup>*1</sup>	50 — 80dB	600kHz (603kHz) <sup>*1</sup>	T301	Régler de telle manière que la tension entre la borne 35 et la terre soit au maximum.
6	1.400kHz (1.395kHz) <sup>*1</sup>	50 — 80dB	1.400kHz (1.395kHz) <sup>*1</sup>	TC302	
7	Répéter les étapes 4 et 6 jusqu'à ce que la norme de tension maximum soit satisfaisante dans les deux étapes.				
8	600kHz (603kHz) <sup>*1</sup>	100dB	600kHz (603kHz) <sup>*1</sup>	VR301	Régler de sorte que la tension entre la borne 35 et la masse soit de 4,9V ( $\pm 0,1V$ ). <sup>*2</sup>

\*1: La fréquence entre les parenthèses est la fréquence à l'intervalle de 9kHz (modèles HE et HB).

\*2: Ne pas laisser la tension de la borne 35 dépasser 5,2V.

### Réglage de la Section FM

Remarque: La méthode de réglage de cette section FM est simple du début jusqu'à la fin.

- Effectuer le câblage comme indiqué dans la figure 7-2.
- Enclencher la touche FM et désenclencher les touches REC LEVEL CHECK et MUTING.

Etape	FM SG (1kHz, $\pm 75kHz$ de déviation)		Indication de fréquence de F-91	Point de réglage	Réglages
	Fréquence	Niveau			Norme
1	Aucun signal		108MHz	L3	Régler de telle manière que la tension entre la borne 33 et la terre soit égale à 23,5V ( $\pm 0,2V$ ).
2			87,5MHz	...	Vérifier si la tension entre la borne 33 et la terre est égale à 7,5V ( $\pm 1,0V$ ).
3	90MHz	40dB	90MHz	L1, T1, L2	Régler de telle manière que la tension entre la borne 22 et la terre soit au maximum.
4	106MHz	40dB	106MHz	TC1-3	
5	Répéter les étapes 3 et 4 jusqu'à ce que les deux normes de tension de masse soit atteintes. Parachever le réglage avec l'étape 4.				
6	106MHz	60dB	106MHz	T103-a	Régler la tension sur 0V pour les bornes 24 à 26.
7	98MHz	18dB (Modulation stéréo)*	98MHz	VR103	Régler au point situé juste avant que l'assourdissement n'entre en service.
8	98MHz	40dB	98MHz	—	Vérifier le niveau de sortie de la borne de sortie.
9	Enclencher la touche REC LEVEL CHECK.			VR302	A l'étape 8, régler le niveau de sortie de la borne de sortie sur -6dB ( $\pm 1dB$ ).

\* Modulation stéréo: Principale 1kHz, G-D,  $\pm 68,25kHz$  dév. pilote 19kHz,  $\pm 6,75kHz$  dév.

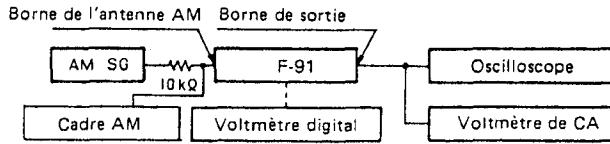

Fig.7-1 Diagramme de câblage de réglage AM

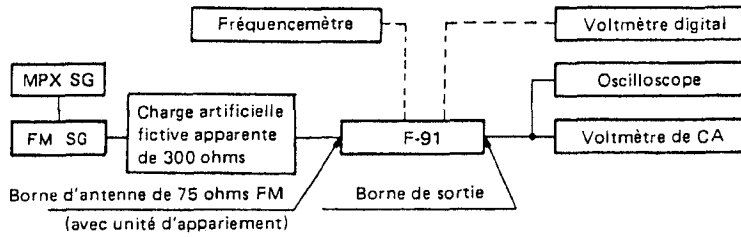

Fig.7-2 Diagramme de câblage de réglage FM

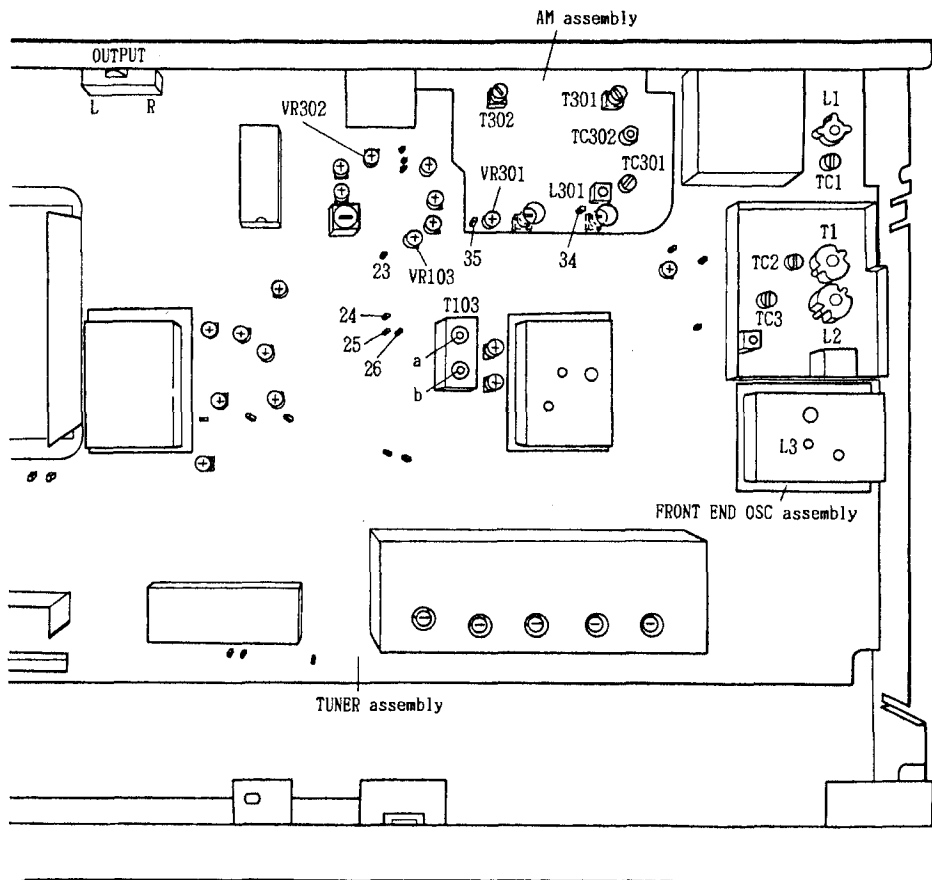

Fig.7-3 Point de réglage



## 7. AJUSTE

### Ajustes de la Sección AM

- Ejecutar el alambrado como se muestra en la figura 7-1.
- Ponga la tecla AM en ON, y la tecla REC LEVEL CHECK en OFF.

Paso	AM SG (400Hz, 30% de modulación)		F-91 indicación de frecuencia	Punto de ajuste	Ajustes
	Frecuencia	Nivel			Estándar
1	Ninguna señal		530kHz (531kHz)* <sup>1</sup>	L301	Ajustar de modo que el voltaje entre el terminal 33 y la tierra sea de 2V (±0,3V).
2			1.700kHz (1.602kHz)* <sup>1</sup>	TC301	Ajustar de modo que el voltaje entre el terminal 33 y la tierra sea de 24,5V (±0,5V).
3	Repetir los pasos 1 y 2 hasta que ambos estándares de voltaje de tierra sean satisfechos.				
4	Ponga VR301 mecánicamente en el punto central.				
5	600kHz (603kHz)* <sup>1</sup>	50 – 80dB	600kHz (603kHz)* <sup>1</sup>	T301	Ajustar de modo que el voltaje entre el terminal 35 y la tierra sea máximo.
6	1.400kHz (1.395kHz)* <sup>1</sup>	50 – 80dB	1.400kHz (1.395kHz)* <sup>1</sup>	TC302	
7	Repetir los pasos 5 y 6 hasta que el estándar de voltaje máximo sea satisfecho en ambos pasos.				
8	600kHz (603kHz)* <sup>1</sup>	100dB	600kHz (603kHz)* <sup>1</sup>	VR301	Ajuste de forma que la tensión entre el terminal 35 y masa sea de 4,9V (±0,1V). <sup>2</sup>

\*1: La frecuencia entre paréntesis corresponde a 9kHz STEP (modelos HE y HB).

\*2: No deje que la tensión del terminal 35 sobrepase los 5,2V.

### Ajuste de la Sección FM

Nota: El método de ajuste de esta sección de FM es muy sencillo.

- Ejecutar el alambrado como se muestra en la figura 7-2.
- Ponga la tecla FM en ON, y las teclas REC LEVEL CHECK y MUTING en OFF.

Paso	FM SG (1kHz, ±75kHz de desviación)		Indicación de frecuencia de F-91	Punto de ajuste	Ajustes
	Frecuencia	Nivel			Estándar
1	Ninguna señal		108MHz	L3	Ajustar de modo que el voltaje entre el terminal 33 y la tierra sea de 23,5V (±0,2V).
2			87,5MHz	...	Verificar si el voltaje entre el terminal 33 y la tierra es de 7,5V (±1,0V).
3	90MHz	40dB	90MHz	L1, T1, L2	Ajustar de modo que el voltaje entre el terminal 22 y la tierra sea máximo.
4	106MHz	40dB	106MHz	TC1-3	
5	Repita los pasos 3 y 4 hasta obtener ambos valores de tensión. Termine el ajuste con el paso 4.				
6	106MHz	60dB	106MHz	T103-a	Ajuste la tensión a 0V para los terminales 24 a 26.
7	98MHz	18dB (Modulación estéreo)*	98MHz	VR103	Ajuste el punto justamente antes de que se aplique el silenciamiento.
8	98MHz	40dB	98MHz	-	Compruebe el nivel de salida del terminal de salida.
9	Ponga la llave REC LEVEL CHECK en ON.			VR302	En el paso 8, ajuste el nivel de salida del terminal de salida a -6dB (±1dB).

\* Modulación estéreo: Principal 1kHz, L-R, piloto de ±68,25kHz de desviación 19kHz, desviación de ±6,75kHz



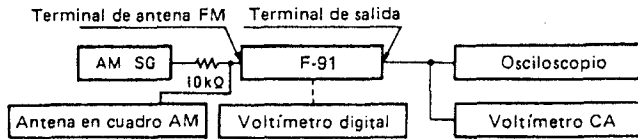

Fig. 7-1 Esquema de alambado de ajuste AM

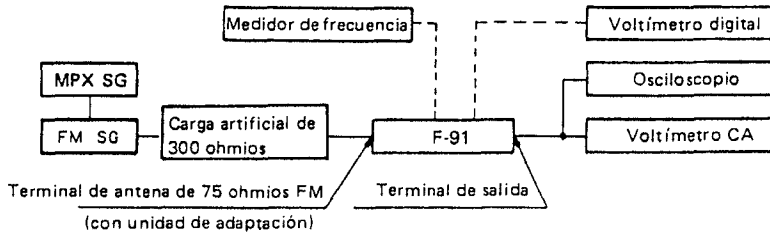

Fig. 7-2 Esquema de alambado de ajuste FM

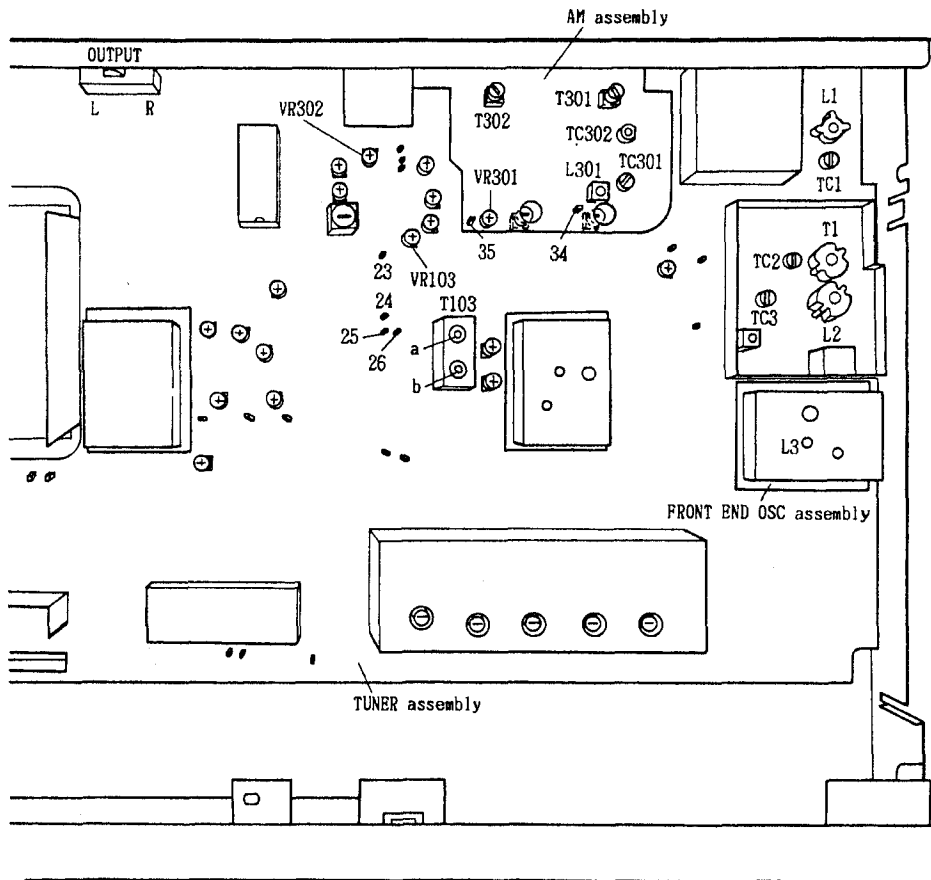
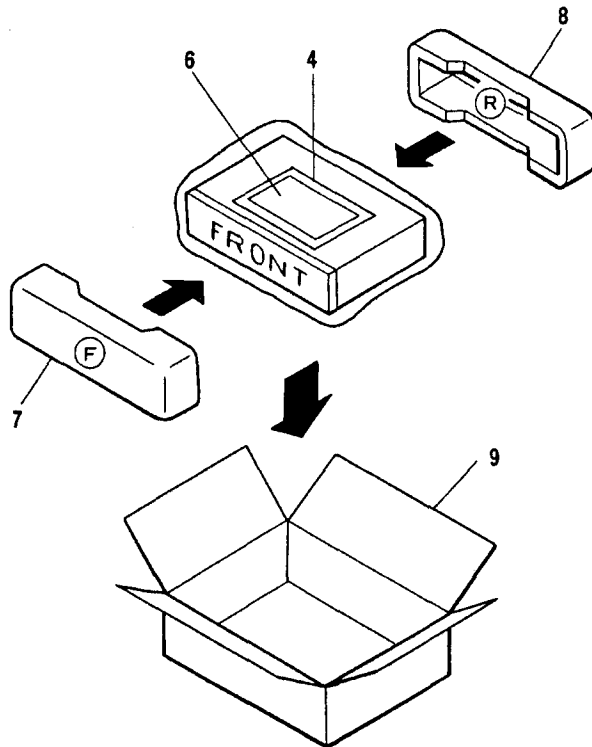
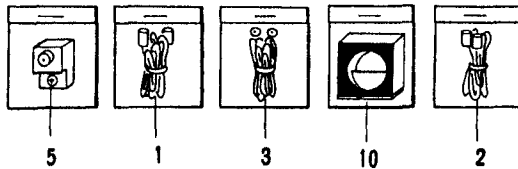

Fig. 7-3 Punto de ajuste

# 8. PACKING

## Parts List

Mark	No.	Part no.	Description
	1	ADE-081	Connector cord with pin plug
	2	ADE-085	Connector cord with mini plug
	3	ADH-005	FM antenna
	4	AHG-153	Catalog bag
	5	AKX-080	Antenna adaptor
	6	ARB1075	Operating instructions (English)
	7	AHA1083	Front pad
	8	AHA1084	Rear pad
	9	AHD1259	Packing case
	10	ATB-086	Loop antenna assembly (L901)





■ PD5056 (IC502)

● Pin Functions

Pin	Pin name	Function & Operation	I/O	Active	Pin	Pin name	Function & Operation	I/O	Active	
1	V <sub>CC</sub>	Power supply (5V)	-	-	33	P5 <sub>7</sub>	KEY MATRIX INPUT	I	-	
2	AV <sub>SS</sub>	Analog ground (0V)	-	-	34	P5 <sub>6</sub>		I	-	
3	V <sub>REF</sub>	Reference voltage input (5V)	-	-	35	P5 <sub>5</sub>		I	-	
4	D-A	N.C.	-	-	36	P5 <sub>4</sub>		I	-	
5	PWM	N.C.	-	-	37	P5 <sub>3</sub>		I	-	
6	P6 <sub>3</sub>	Compulsion MONO	N	H	38	P5 <sub>2</sub>		I	-	
7	P6 <sub>2</sub>	VCO KILLER (AM ON)	N	H	39	P5 <sub>1</sub>		I	-	
8	P6 <sub>1</sub>	Hi-Blend	N	H	40	P5 <sub>0</sub>		I	-	
9	P6 <sub>0</sub>	MUTE CONTROL	N	H	41	P1 <sub>7</sub>		S METER display (LSB)	N	L
10	AN <sub>7</sub>	FM S METER ⊙ (A/D)	I	-	42	P1 <sub>6</sub>	(2)		N	L
11	AN <sub>6</sub>	FM S METER ⊙ (A/D)	I	-	43	P1 <sub>5</sub>	(3)		N	L
12	AN <sub>5</sub>	0-VOLT MUTE (A/D)	I	-	44	P1 <sub>4</sub>	(4)		N	L
13	AN <sub>4</sub>	AM S METER (A/D)	I	-	45	P1 <sub>3</sub>	(5)		N	L
14	P4 <sub>3</sub>	9k/10k input (H=10k)	I	-	46	P1 <sub>2</sub>	(6)		N	L
15	P4 <sub>2</sub>	AM & REC CHECK CUT (AM or REC CHECK → H)	N	H	47	P1 <sub>1</sub>	(7)		N	L
					48	P1 <sub>0</sub>	(MSB)		N	L
16	P4 <sub>1</sub>	REC LEVEL CHECK	N	H	49	P0 <sub>7</sub>	LEVEL ADJ. CONT (0-VOLT MUTE ON=L)	N	L	
17	P4 <sub>0</sub>	N.C.	N	H	50	P0 <sub>6</sub>	Test ⊙ (DET)	I	L	
18	P3 <sub>7</sub>	MW +B CONTROL	N	H			(L → test data load and FM +B OFF)			
19	P3 <sub>6</sub>	ANTENNA A/B (A → H)	N	H	51	P0 <sub>5</sub>	Test (L → test data load) (FE)	I	L	
20	P3 <sub>5</sub>	STEREO information (L=STEREO)	I	-	52	P0 <sub>4</sub>	KEY MATRIX OUTPUT	N	-	
21	P3 <sub>4</sub>	LPF CONT (OV MUTE ON=H)	N	H	53	P0 <sub>3</sub>		N	-	
22	P3 <sub>3</sub>	STEREO IND.	N	L	54	P0 <sub>2</sub>		N	-	
23	INT <sub>2</sub>	Interrupt for back up (AC input)	I	-	55	P0 <sub>1</sub>		N	-	
24	P3 <sub>1</sub>	N.C.	N	L	56	P0 <sub>0</sub>		N	-	
25	P3 <sub>0</sub>	Remote control data input	I	-	57	P2 <sub>7</sub>		FM +B CONTROL	O	H
26	INT <sub>1</sub>	(5V Pull Up)	-	-	58	P2 <sub>6</sub>	PLL lock	-	-	
27	CNV <sub>SS</sub>	GND	-	-	59	P2 <sub>5</sub>	PL blank ("L" at Power ON)	O	H	
28	RESET	Power ON reset	I	L	60	P2 <sub>4</sub>	LC7570 (No.2) enable line	O	-	
29	X <sub>1IN</sub>	Oscillator input (f <sub>o</sub> = 4MHz)	I	-	61	P2 <sub>3</sub>	LC7570 (No.1) enable line	O	-	
30	X <sub>0OUT</sub>	Oscillator output	O	-	62	P2 <sub>2</sub>	PLL enable line	O	-	
31	φ	N.C.	-	-	63	P2 <sub>1</sub>	Data line for serial data translator	O	-	
32	V <sub>SS</sub>	GND	-	-	64	P2 <sub>0</sub>	Clock line for serial data translator	O	-	

I: CMOS INPUT    O: CMOS OUTPUT    N: Nch OPEN

● Pin connections (Top view)

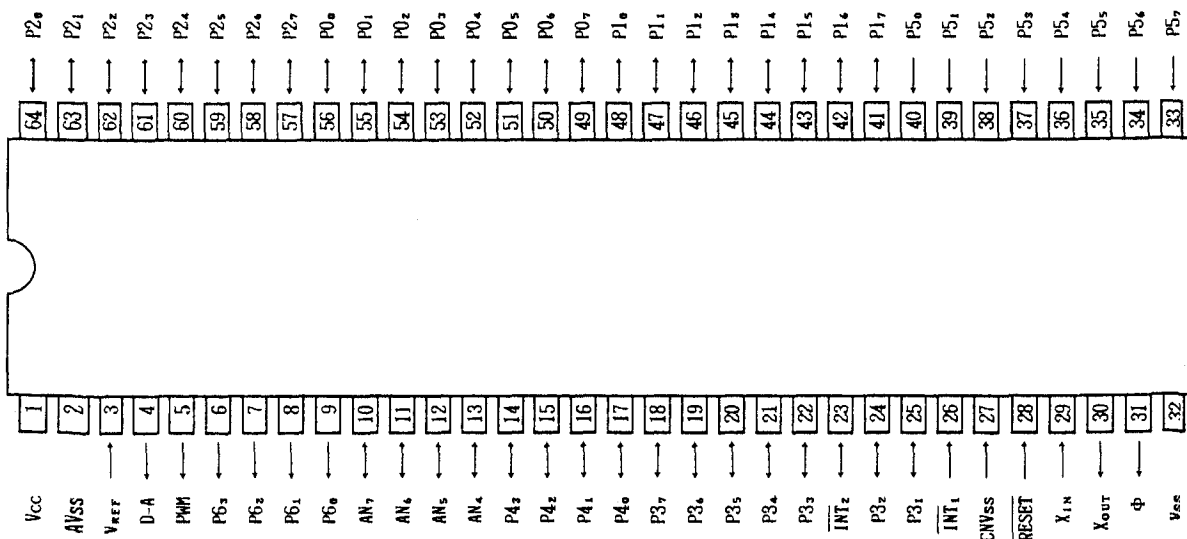





## 11. CIRCUIT DESCRIPTION

### 11.1 New IF system principle

Fig.11-1 (a) shows the conventional IF system which band is wide position, and Fig.11-1 (b) shows the new IF system.

Vertical line indicates the time variable of desired signal.

The line at right side of desired signal indicates undesired signal.

Mountainous curve shows the amplitude characteristic of IF filter.

In the case of conventional system, signal pass through the filter without generate the distortion so that filter is wide. At this time, the system is affected by undesired signal.

In the case of new system, signal pass through directly so that narrow filter follow the signal. Besides, the system is not affected by undesired signal.

This system's filter is controlled by feedforward control, therefore, stability is very high and not oscillation.

This system organize the equivalent follow type filter so that input FM signal frequency controlled for center of the filter at any time. (At conventional system, filter is followed the input signal.)

Fig.11-2 shows the block diagram. System is consists of the control block and filter block. Control block is consists of band-pass filter (BPF1), FM detector (DET1) and low-pass filter (LPF).

The band-pass filter (BPF1) has the same characteristic as conventional tuner's narrow filter, and this filter has selective characteristic sufficiently.

When FM signal is inputted, FM signal is detected by FM detector (DET1) after pass through the band-pass filter (BPF1). And then, output signal of FM detector (DET1) is cut the useless high-frequency elements by low-pass filter (LPF).

Filter block is consists of two mixer (MIX1 and 2), band-pass filter (BPF2) and VCO.

Mixer 1 (MIX1) perform frequency change so that multiply input FM signal by VCO output.

F-91 introduce the secondary IF frequency as 13.45 MHz.

Band-pass filter (BPF2) has the same narrow bandwidth characteristic as the band-pass filter (BPF1).

This filter (BPF2) cut the obstruction wave including input signal.

Input signal of passed through the band-pass filter (BPF2) is multiplied by VCO output at mixer (MIX2) again, then change to the original frequency.

Original signal is detected by FM detector (DET2), then audio output is obtained.

In this way, in spite of use the filter of fixed the center frequency, F-91 operate to the variable filter so that center frequency follow the input signal as equivalent.

If desired signal (S) and undesired signal (U) apply to input as shown in Fig.11-2, first, these signals are applied to control block, and cut the undesired signal (U) by BPF1. At this time, desired signal is distorted by BPF1.

This desired signal without undesired signal is detected by FM detector (DET1), then changed the FM waveform by VCO again.

Output signal of VCO is sum of the desired signal (S) and the distortion element (D).

This distortion element (D) not only include generated distortion at filter (BPF1) but also include generated distortion at detector and VCO.

On the other hand, desired signal (S) and undesired signal (U) apply to the filter block, then mix with the VCO output. Direction of desired signal's modulation is same way as input signal.

The differential element is took out from mixer 1 (MIX1)'s output by BPF2. At this time, desired signal (S) is vanished and undesired signal (U) is eliminated by BPF2.

Therefore, only distortion element (D) pass through the BPF2.

When distortion element (D) pass through the BPF2, element (D) hardly distort so that frequency deviation of the distortion element (D) is just a little.

And signal is mixed with VCO output by mixer 2 (MIX2) and pick up the differential element again. Then, desired signal (S) is obtained to not distortion. At this time, undesired signal (U) has eliminated.

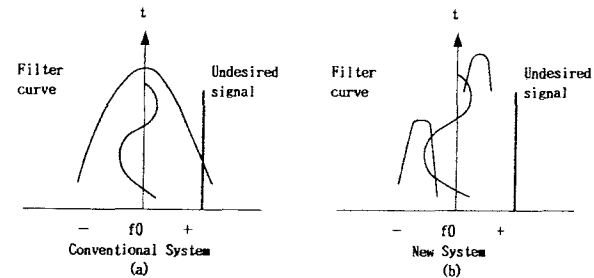

Fig.11-1 Signal tracing characteristics

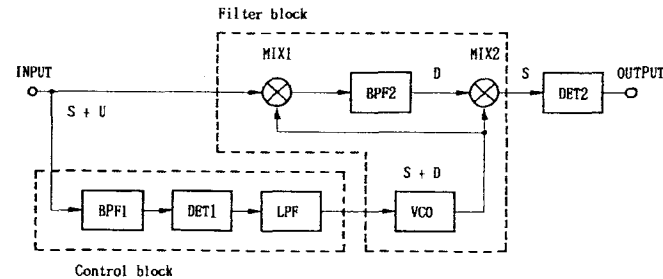

Fig.11-1 Blockdiagram of Active Real-time Tracing System

## 12. FOR HE, HB, HEZ AND SD/G TYPES

**NOTES:**

- Parts without part number cannot be supplied.
  - Parts marked by "⊙" are not always kept in stock. Their delivery time may be longer than usual or they may be unavailable.
  - The Δ mark found on some component parts indicates the importance of the safety factor of the part. Therefore, when replacing, be sure to use parts of identical designation.
  - For your parts Stock Control, the fast moving items are indicated with the marks ★★ and ★.
- ★★ **GENERALLY MOVES FASTER THAN ★**  
 This classification shall be adjusted by each distributor because it depends on model number, temperature, humidity, etc.

### Contrast of Miscellaneous Parts.

The F-91/HE, HB, HEZ and SD/G types are the same as the F-91/KU/CA type with the exception of the following sections.

Mark	Symbol & Description	Part No.					Remarks
		F-91/KU/CA type	F-91/HE type	F-91/HB type	F-91/HEZ type	F-91/SD/G type	
Δ	TUNER assembly	AWZ1568	AWZ1567	AWZ1567	AWZ1566	AWZ1569	
	REMOCON assembly	Non supply	••••	••••	••••	Non supply	
	Acrylic panel	AAK1298	AAK1303	AAK1303	AAK1303	AAK1298	
	FL filter	AAK1300	AAK1299	AAK1299	AAK1299	AAK1300	
	Connection cord with Mini plug	ADE-085	••••	••••	••••	ADE-085	
	AC power cord	ADG-088	ADG1021	ADG-063	ADG1010	ADG-088	
	FM antenna	ADH-005	••••	••••	••••	ADH-005	
	FM antenna assembly	••••	ADH1002	ADH1002	ADH1002	••••	
	Antenna adaptor	AKX-080	••••	••••	••••	AKX-080	
	Side board L	AMS1015	AMS1019	AMS1015	AMS1019	AMS1015	
Side board R	AMS1016	AMS1020	AMS1016	AMS1020	AMS1016	For packing	
Operating instructions (English)	ARB1075	••••	ARB1075	••••	ARB1075		
(English / German / French / Italian)	••••	ARE1054	••••	••••	••••		
(German)	••••	••••	••••	ARC1051	••••		
(Spanish)	••••	••••	••••	••••	ARC1068		
Δ ★	Power transformer (T901) (AC120V)	ATT1043	••••	••••	••••	••••	For 2P pin-jack
	(AC220/240V)	••••	ATT1045	ATT1045	ATT1045	••••	
	(AC110/120-127/220/240V)	••••	••••	••••	••••	ATT1044	
	Screw	••••	••••	••••	ABA1035	••••	
	Spacer	••••	••••	••••	••••	AHB1021	
	Packing case	AHD1259	AHD1259	AHD1259	AHD1259	AHD1260	For packing

**TUNER Assembly**

The TUNER assembly AWZ1567 (HE and HB types), AWZ1566 (HEZ type) and AWZ1569 (SD/G type) are the same as the AWZ1568 (KU/CA type) with the exception of the following sections.

Mark	Symbol & Description	Part No.				Remarks
		AWZ1568	AWZ1567	AWZ1566	AWZ1569	
	C215, C216	CQMXA242J100	CQMXA182J100	CQMXA182J100	CQMXA182J100	
	R178	RD1/8PM822J	RD1/8PM473J	RD1/8PM473J	RD1/8PM473J	
	R214, R215	RN1/4PQ3162F	RDR1/4PM303J	RDR1/4PM303J	RDR1/4PM303J	
	R408 (2.2M $\Omega$ , 1/2W)	ACN-209	.....	.....	.....	
	R420, R421	RS1LMF181J	.....	.....	.....	
	R422	RS2LMF181J	.....	.....	.....	
	R530	RD1/8PM102J	.....	.....	RD1/8PM102J	
	Pal socket	.....	AKX1013	AKX1013	.....	
	C3 (0.01/25V)	ACG-036	ACG-036	.....	ACG-036	
	C3, C42	.....	.....	CCDCH150J50	.....	
	C41	.....	.....	CCCSL101J50	.....	
	C43	.....	.....	CKDYX104M25	.....	
	C267, C268 (0.01/25V)	.....	.....	ACG-036	.....	
	C270, C271	.....	.....	CQSA152J160	.....	
	L2 FM RF coil	ATC-205	ATC-205	.....	ATC-205	
	L206, L207	.....	.....	LAU2R2M	.....	
	L208, L209	.....	.....	LAU101K	.....	
	L401 Line filter	.....	.....	ATF-151	.....	
	R33	.....	.....	RD1/8PM472J	.....	
	T4 FM RF transformer	.....	.....	ATC-257	.....	
★★	Q210, Q211	.....	.....	.....	2SK161	
	R259, R260	.....	.....	.....	RD1/8PM105J	
★★	S501 Slide switch (CHANNEL STEP/FM DE-EMPHASIS)	.....	.....	.....	ASH1009	
△★★	S902 Voltage selector (AC110/120-127/220/240V)	.....	.....	.....	AKX-505	
	C265, C266	.....	.....	.....	CQMA821J50	
	R34	RD1/2PM103J	.....	.....	.....	