

ATTENTION:

- GENERAL MANAGER
- PARTS MANAGER
- CLAIMS PERSONNEL
- SERVICE MANAGER

IMPORTANT - All Service Personnel Should Read and Initial in the boxes provided, right.



QUALITY DRIVEN® SERVICE

SERVICE BULLETIN

APPLICABILITY: 2013MY Legacy and Outback 2.5L Models
 2012-13MY Impreza 2.0L Models
 2013MY XV Crosstrek
 2011-2014MY Forester NA Models Only
 2013MY BRZ

NUMBER: 11-130-13
DATE: 04/05/13

SUBJECT: Difficulty Starting, Rough Idle, Cam Position or Misfire DTCs
 P0340, P0341, P0345, P0346, P0365, P0366, P0390, P0391,
 P0301, P0302, P0303 or P0304

INTRODUCTION

This Bulletin provides inspection and repair procedures for intake and exhaust camshaft position-related and/or engine misfire DTCs for the FA and FB engine-equipped models listed above. The camshaft position sensor (CPS) clearance may be out of specification causing these condition(s) and one or more of the DTCs listed above to set. In addition to a Check Engine light coming on, there may or may not be customer concerns of rough idle, extended cranking or no start.

NOTES:

- **This Service Bulletin will replace Bulletin numbers 11-100-11R, 11-122-12, 11-124-12R and 11-125-12.**
- **Read this Bulletin completely before starting any repairs** as service procedures have changed.
- An exhaust cam position sensor clearance out of specification will **NOT** cause a startability issue.

COUNTERMEASURE IN PRODUCTION

MODEL	STARTING VIN
Legacy	D*038918
Outback	D*295279
Impreza 4-Door	D*020700
Impreza 5-Door	D*835681
XV Crosstrek	
Forester	E*410570
BRZ	D*607924

NOTE: These VINs are for reference only. There may be a small number of vehicles after the starting VINs listed above which do not have the countermeasure due to production sequence changes.

continued...

<p>CAUTION: VEHICLE SERVICING PERFORMED BY UNTRAINED PERSONS COULD RESULT IN SERIOUS INJURY TO THOSE PERSONS OR TO OTHERS.</p> <p>Subaru Service Bulletins are intended for use by professional technicians ONLY. They are written to inform those technicians of conditions that may occur in some vehicles, or to provide information that could assist in the proper servicing of the vehicle. Properly trained technicians have the equipment, tools, safety instructions, and know-how to do the job correctly and safely. If a condition is described, DO NOT assume that this Service Bulletin applies to your vehicle, or that your vehicle will have that condition.</p>	<p style="text-align: center;">SUBARU OF AMERICA, INC. IS "ISO 14001 COMPLIANT"</p> <p>The international standard for excellence in Environmental Management Systems. Please recycle or dispose of automotive products in a manner that is friendly to our environment and in accordance with all local, state and federal laws and regulations.</p>
--	---

PART INFORMATION

- Shim Kit, p.n. 10130AA060, contains 8 cam position sensor shims, 0.1 to 0.8mm in thickness.
- Shim Kit, p.n. 10130AA160, contains 8 cam position sensor shims (same thicknesses) to adjust the gap of the right-hand (Bank 1) exhaust camshaft position sensor on BRZ ONLY.
- Camshaft position sensor o-ring, p.n. 13099AA050 (one-time use item).

NOTE: The part numbers shown below are for reference only and cannot be ordered individually. If a shim is required, the corresponding shim kit must be ordered.

PART NUMBER- R/H (B1) EXHAUST ONLY	PART NUMBER- INTAKE AND L/H (B2) EXHAUST ONLY	CLEARANCE (MM)	SHIM THICKNESS (MM)	TARGET GAP (MM)
10130AA170	10130AA070	0.45 - 0.55	0.8	1.25 - 1.35
10130AA180	10130AA080	0.56 - 0.65	0.7	1.26 - 1.35
10130AA190	10130AA090	0.66 - 0.75	0.6	1.26 - 1.35
10130AA200	10130AA100	0.76 - 0.85	0.5	1.26 - 1.35
10130AA210	10130AA110	0.86 - 0.95	0.4	1.26 - 1.35
10130AA220	10130AA120	0.96 - 1.05	0.3	1.26 - 1.35
10130AA230	10130AA130	1.06 - 1.15	0.2	1.26 - 1.35
10130AA240	10130AA140	1.16 - 1.25	0.1	1.26 - 1.35

SPECIAL TOOLS

- Pulse/Analog Box, SDI Box and SSMIII
- Digital Caliper with depth attachment or 1” Depth Micrometer
- If you do not have a depth attachment or a 1” Depth Micrometer, use a flat washer, (outside diameter 25.5mm, inside diameter 11.1mm, 7.72mm thick) or equivalent. The purpose of the flat washer is to provide a surface for the caliper to rest on while making the sensor clearance measurements.

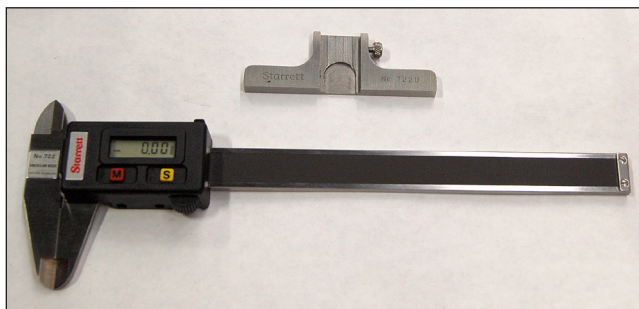

Digital Caliper with Depth Attachment

continued...

SERVICE PROCEDURE / INFORMATION

The Service Procedure of this Bulletin will have 2 sections, one for the intake cam position sensors and a second for the exhaust.

Check the waveforms of the applicable sensor (intake and / or exhaust) using the Pulse/ Analog Box, SDI Box and the oscilloscope function of the SSMIII. For detailed information and operating instructions, refer to the applicable Service Manual or the Subaru Diagnostic System (SDS) SSMIII User Guide. Click on “Help” at the top of the SSMIII Main Menu screen for the User Guide and additional helpful information.

IMPORTANT: When back-probing the ECM connectors to attach oscilloscope leads, refer to the wiring schematic for the specific DTC being diagnosed in the applicable Service Manual for proper connector and pin terminal locations.

Understanding the Relationships between the Crank and Camshaft Position Sensors

When setting up your oscilloscope to check Camshaft Position Sensor data, also select the Crankshaft Position Sensor data to help your understanding. It is important to arrange your selections in the order shown in the following screen shot examples. The Crank sensor data will make it easier to establish the firing order and identify cam sensor waveform inconsistencies. **Example 1** on the next page is a perfectly normal pattern for all 3 sensors. Let's look at some specifics of the data which will help you determine a “good” pattern versus a “bad” one.

Looking at the crank signal on page 4, you will see the difference between what we will call “1's” (a single spike) and “2's” (a double spike). This helps establish the engine's firing order and what the corresponding cam sensor data should look like. The ECM looks for the “Edges” of the cam position sensor voltage drops to be within specified time “Window” parameters. The chart below Example 1 on the next page will help bring this all together. (Range was set to 250 msec / div. so the crank signal would be easier to understand here.)

continued...

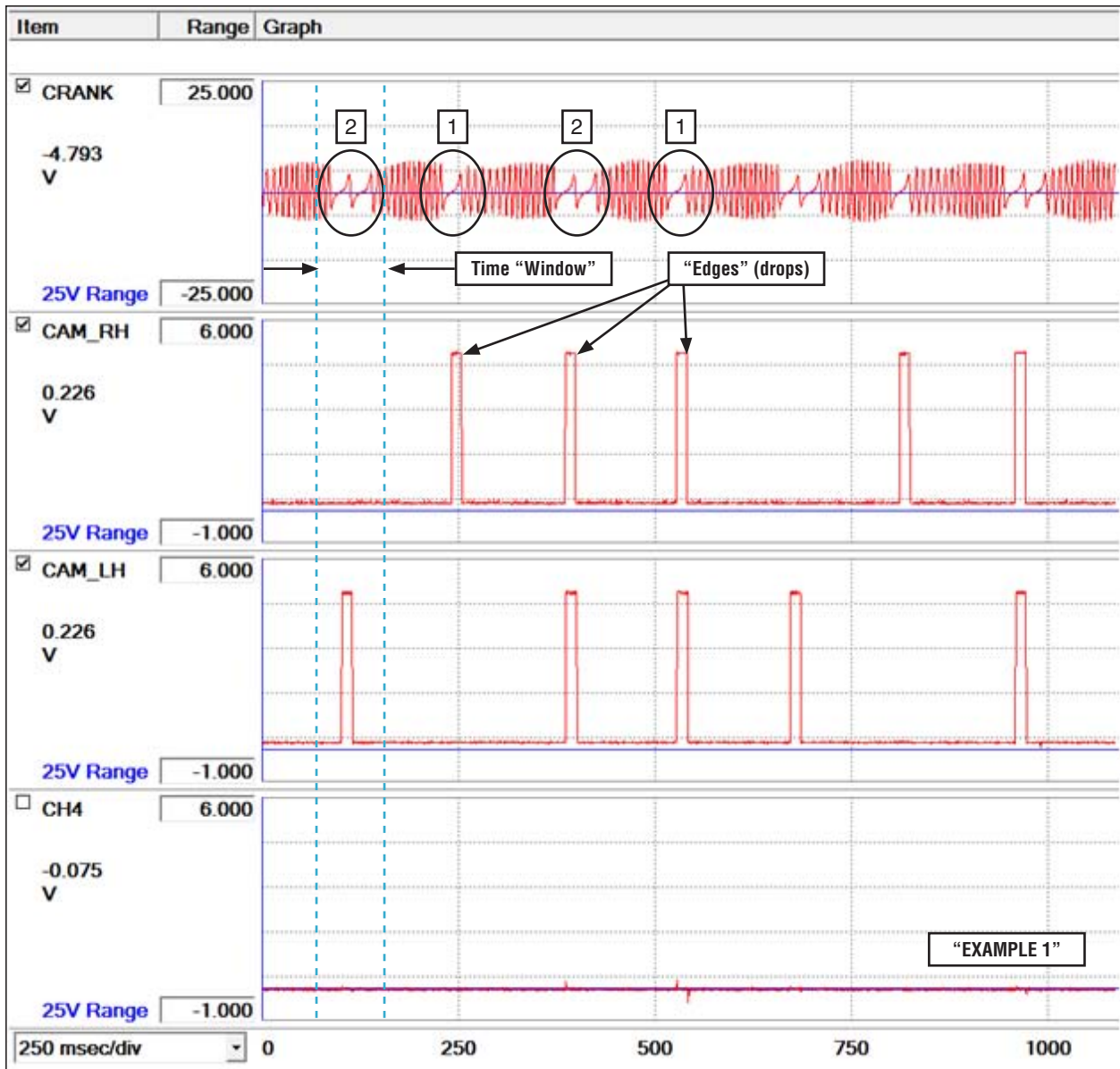

Engine Firing Order	#1	#3	#2	#4
Crank Signal ("1" or "2"?)	"1"	"2"	"1"	"2"
Is Cam Signal Edge Within Window RH?	Yes	No	Yes	Yes
Is Cam Signal Edge Within Window LH?	Yes	Yes	No	Yes

NOTE: A LH cam position sensor signal does not always indicate a corresponding #2 or #4 cylinder firing. (The same applies to the RH side.)

Using the chart above and comparing it to **Example 1**, it can be determined the first cylinder shown in the screen shot is #3 because the crank signal is a "2" and there is an edge signal within the window on the LH but not the RH cam sensor. Next cylinder in the firing order would be #2 as the crank position signal is a "1" and there is an edge signal in the window for the RH but not for the LH, and so on...

continued...

Example 2 below shows a “Bad” pattern for the RH cam sensor. Marks #1 and #2 show what appears to be #4 cylinder firing but, the next cylinder to fire according to the screen shot is #2 followed by #4 then #1. The pattern for the RH sensor never shows the proper sequence to fire #3 cylinder. In this case, recheck the data again after installing a .2mm shim under the RH cam sensor.

Proper Firing Order is: #3 #2 #4 #1 #3 #2

Firing Order shown in screen shot: #4 #2 #4 #1 #4 #2

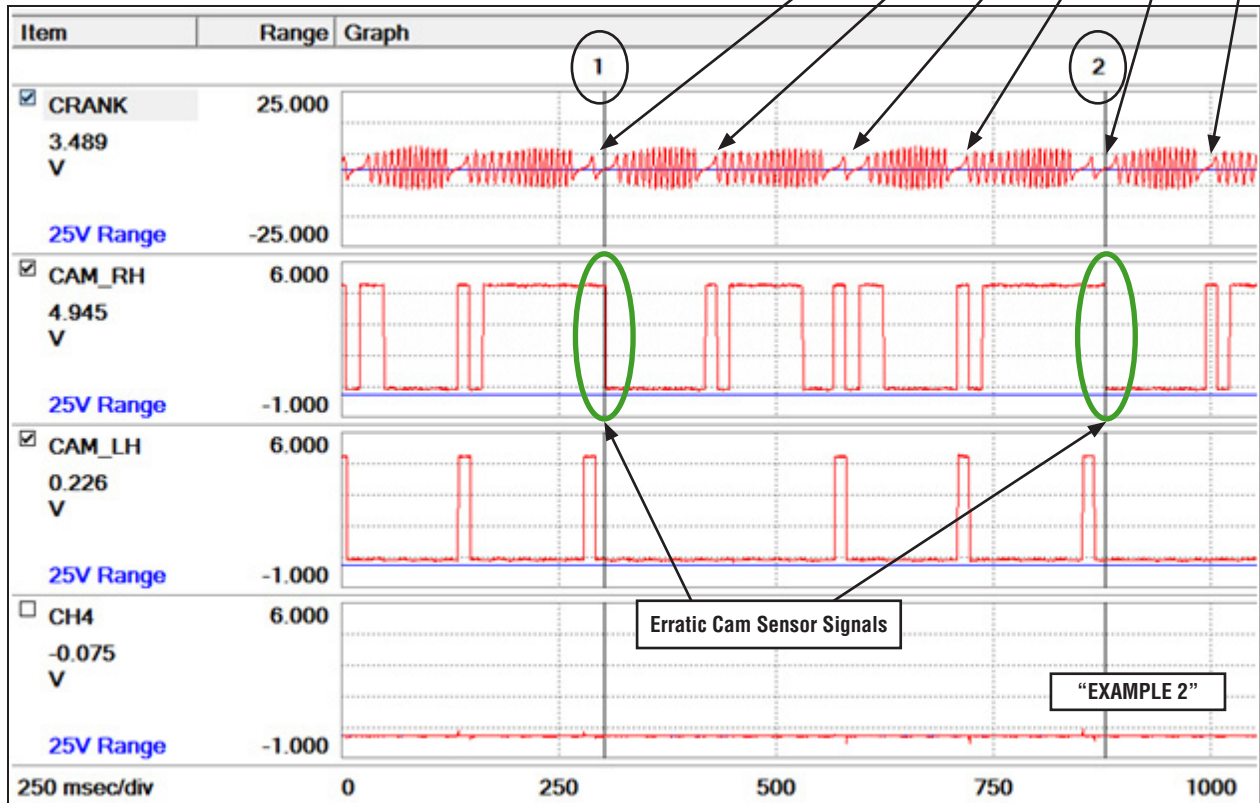

continued...

Example 3 shows what *appears* to be an erratic signal from the RH cam sensor but, you can see all the cam sensor data signal edges (drops) follow the chart and firing order as they are supposed to. Other signal edges (rises or drops) outside the “window” or a longer time line as shown here prior to the #4 signal edges seen on the RH cam sensor pattern are examples of signals which will be “ignored” by the ECM and are not a cause for concern.

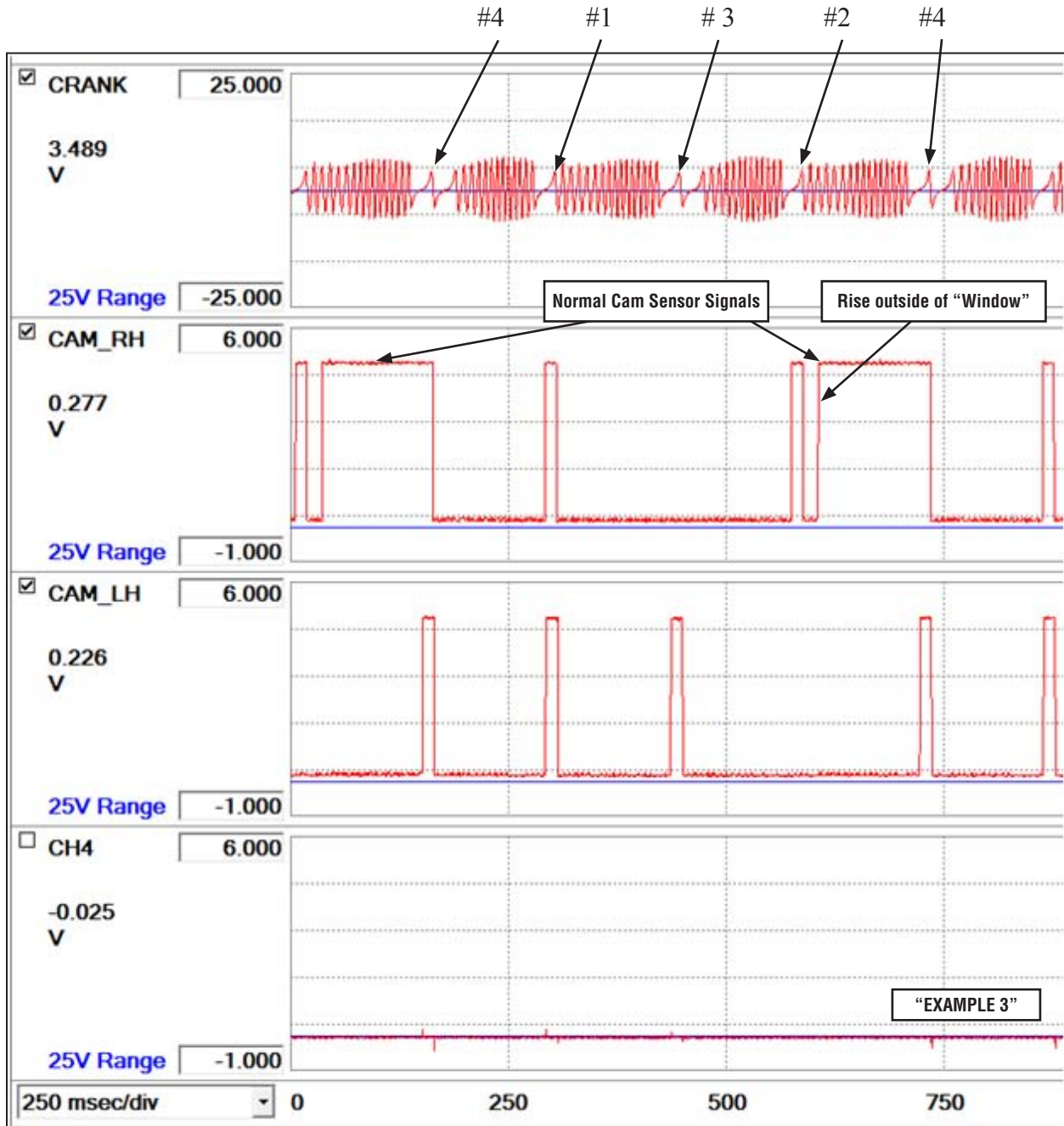

continued...

IMPORTANT: If you confirm an irregular wave form pattern, BEFORE performing the measurement and shim selection procedures, install a .2mm shim under the suspect intake or exhaust camshaft position sensor. If there is no change, remove the .2mm shim and install a .4mm shim. **USE ONLY ONE SHIM PER SENSOR, NO STACKING.** If the wave pattern is lost, remove the .4mm shim and replace with a .3mm shim. Recheck the pattern and if it appears normal, complete the repair as shown below. If an abnormal pattern persists, proceed with the rest of the clearance measurement and shim selection procedures.

- a. Install a NEW camshaft position sensor o-ring (one-time use item).
- b. Reinstall the camshaft position sensor and shim.
- c. Torque the sensor retaining bolt to 6.4 Nm (4.7 ft. lbs. or 56.4 inch-pounds).
- d. Reconnect the sensor engine wiring harness connector.
- e. Reconnect the negative battery cable then reset the radio station presets (and navigation system favorites if applicable) to complete the repair.

If an abnormal oscilloscope pattern persists for an **intake** sensor, measure the clearance between the end of the camshaft position sensor and the sensor plate using the following procedure. If a suspect pattern is verified for an **exhaust** sensor, a revised procedure will be outlined later in this Bulletin. If the pattern is normal, refer to the applicable Service Manual for additional troubleshooting and diagnostic procedures for the stored DTCs.

MEASUREMENT AND SHIM SELECTION PROCEDURES

The specified clearance is 1.3 +/- .05mm (1.25 to 1.35mm or .049" to .053").

1. Record the customer's radio station presets (and navigation system favorites if applicable).
2. Disconnect the negative battery cable.
3. Remove the camshaft position sensor from the timing chain cover using the procedure in the applicable Service Manual.

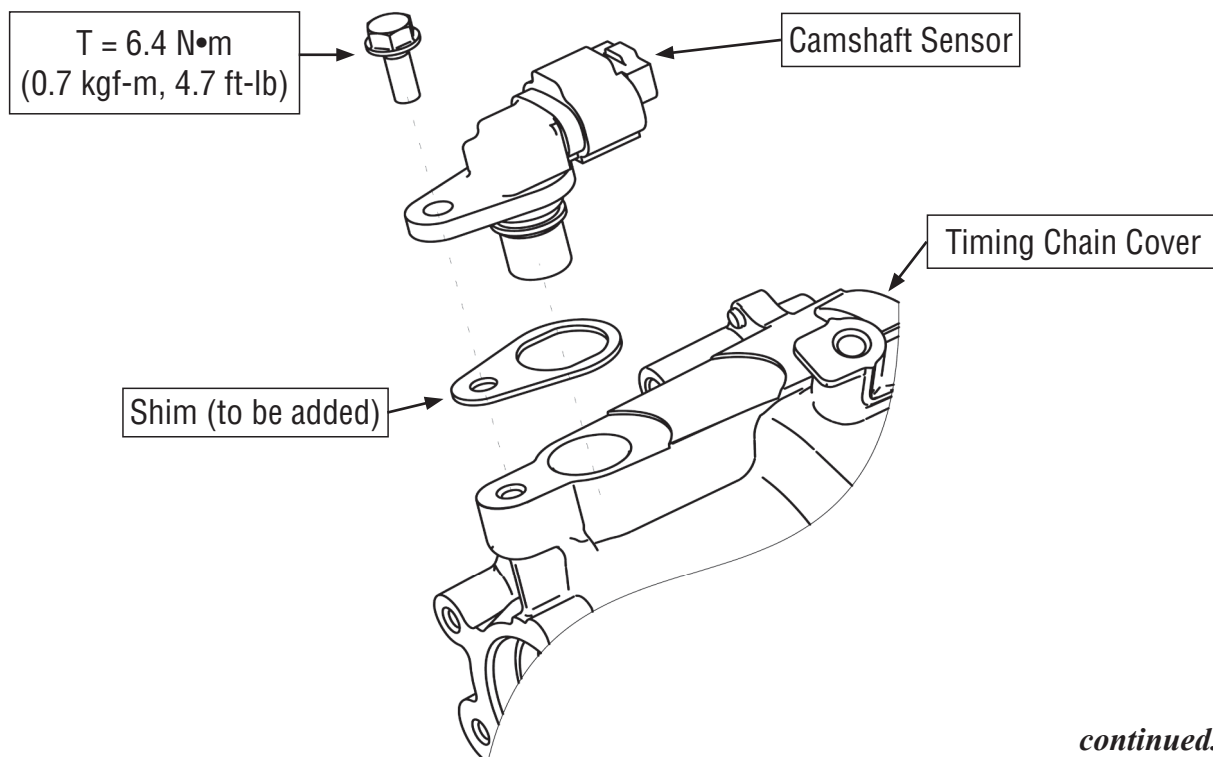

continued...

A = Top of timing chain cover to camshaft position sensor plate

B = Camshaft position sensor mating surface to the bottom of the sensor

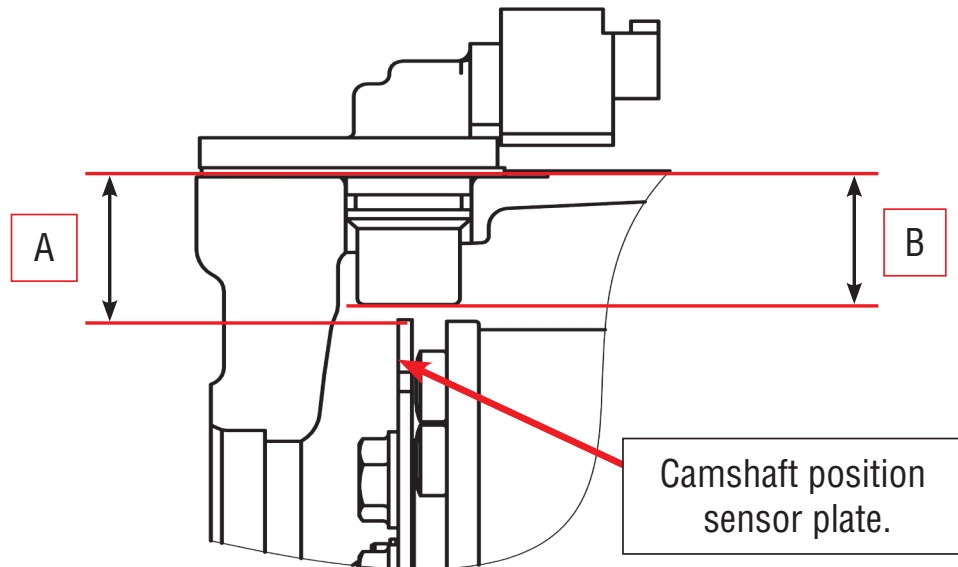

NOTE: When measuring “A”, make sure you are measuring to the outside diameter or “top” of the sensor plate and not to the bottom of a notch as shown below. Be sure to record all measurements.

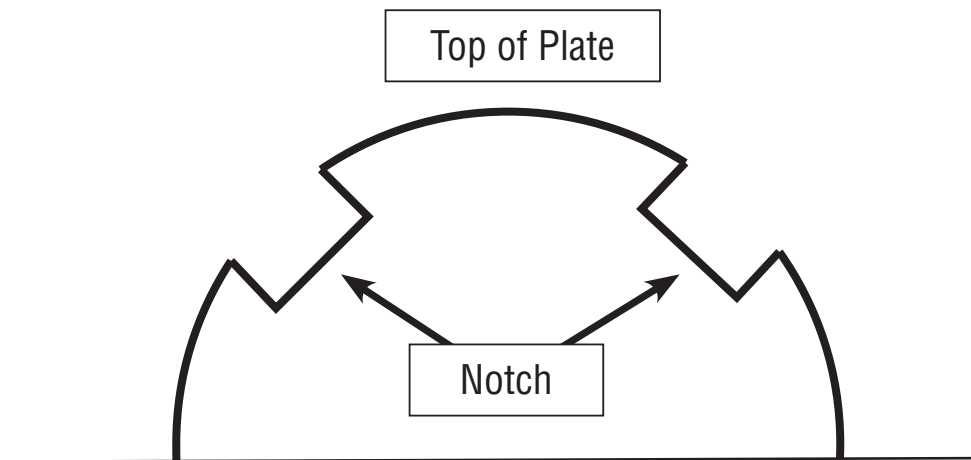

continued...

Measurement taken using digital caliper with depth attachment.



Measurement taken using digital caliper with washer.



IMPORTANT: When using the flat washer, make sure the washer is fully seated on the machined surfaces of the timing cover or your measurements will not be accurate.

1. Take a measurement and record the reading.
2. Using a breaker bar and 22mm socket, place the socket on the crankshaft pulley bolt and rotate the engine clockwise approximately 70°. **CAUTION:** Do not rotate the engine counter-clockwise, doing so will loosen the crankshaft pulley bolt. If the engine is accidentally turned counter-clockwise make sure the bolt is re-torqued following the proper procedure in the applicable Service Manual.
3. Take a measurement and record the reading.
4. Rotate the engine clockwise approximately 70°.
5. Take a measurement and record the reading.
6. Use the smallest of the three measurements and record the result.

continued...

When taking measurement “B”, use a flat steel ruler or equivalent along with the digital caliper.

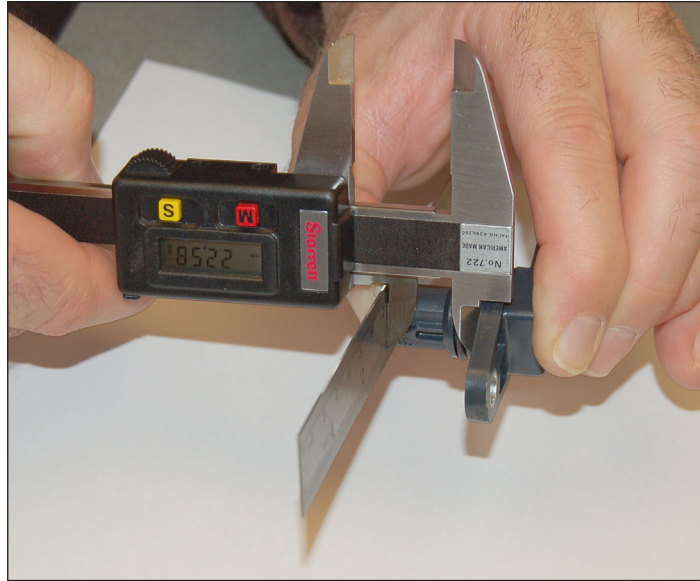

7. Measure the distance between the camshaft position sensor mounting surface and the bottom of the sensor as shown above.

IMPORTANT: Be sure to account for the thickness of the flat washer (if you are using one) when performing your calculations to determine the required shim thickness.

The specified clearance is 1.3 +/- .05mm (1.25 to 1.35mm or .049” to .053”).

Example calculation

(the 1.72mm thickness of the flat washer is **subtracted** from “A” dimension)

A = Top of timing chain cover to camshaft position sensor plate

B = Camshaft position sensor mating surface to the bottom of the sensor

$$A) 25.42 - 1.72 = 23.70$$

$$A = 23.70$$

$$B = 22.58$$

$$A - B = 1.12 \text{ (clearance)}$$

In this example a 0.2 shim is required.

Clearance (mm)	Shim Thickness (mm)	Target Gap (mm)
1.06 – 1.15	0.2	1.26 – 1.35

continued...

8. After the correct shim is selected and a normal oscilloscope pattern has been verified:
 - a. Install a NEW camshaft position sensor o-ring (one-time use item).
 - b. Reinstall the camshaft position sensor and shim.
 - c. Torque the sensor retaining bolt to 6.4 Nm (4.7 ft. lbs. or 56.4 inch-pounds).
 - d. Reconnect the sensor engine wiring harness connector.
 - e. Reconnect the negative battery cable then reset the radio station presets (and navigation system favorites if applicable) to complete the repair.

BRZ EXHAUST CAMSHAFT POSITION SENSOR PROCEDURE

In the event you have a DTC stored for an exhaust camshaft position sensor, the repair procedure has been revised. Due to the position of the right-hand (Bank 1) sensor, measurement of the gap without removing the front catalyst is extremely difficult as shown in the photo below.

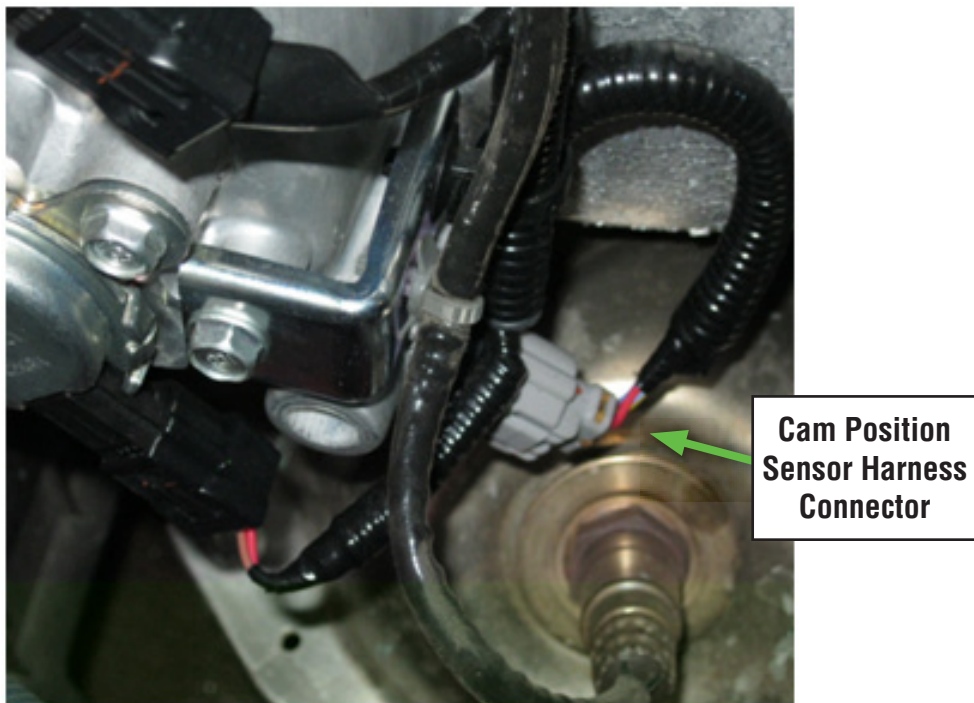

In addition, the engine under-guards must be removed along with the plastic splash shield to access the left-hand (Bank 2) sensor. As a solution, the following procedure has been developed:

1. Confirm the irregular oscilloscope pattern for the corresponding DTC stored.
2. Remove the sensor from the timing cover and install a .2mm thick shim from the applicable kit.
3. Reinstall the sensor, torque the sensor retaining bolt to 6.4 Nm (4.7 ft. lbs. or 56.4 inch-pounds) then recheck the oscilloscope pattern.

continued...

If the pattern is normal, the repair is complete. If the irregular pattern persists, repeat Steps 2 and 3 after removing the .2mm shim and installing a .3 mm thick shim. **ONE SHIM ONLY, NO STACKING.** Repeat as necessary increasing the shim thickness .1 mm at a time until a normal scope pattern can be verified.

4. After the correct shim is selected:

- a. Install a new camshaft position sensor o-ring (one-time use item).
- b. Reinstall the camshaft position sensor and shim.
- c. Torque the sensor retaining bolt to 6.4 Nm (4.7 ft. lbs. or 56.4 inch-pounds).
- d. Reconnect the sensor engine wiring harness connector.
- e. Reconnect the negative battery cable and reset the radio station presets (and navigation system favorites if applicable) to complete the repair.

5. Be sure to clear the ECM memory before returning the vehicle to the customer.

WARRANTY/CLAIM INFORMATION

For vehicles within the Basic New Car Limited Warranty period, this repair may be claimed using the following information:

Labor Description	Labor Operation#	Fail Code	Labor Time
Intake Cam Sensor Measurement and Shim Installation	A817-211	UKM-20	0.5
Exhaust Cam Sensor Measurement and Shim Installation	A817-213		0.6