



## ABOUT THIS MANUAL AND MT Xpress

Thank you for purchasing an **MT Xpress** product.

All of our equipment is assembled and packed with great care. If you should find any incorrect item, please contact your **Xpress** Dealer immediately.

**MT Xpress** products are Weights & Measures approved precision weighing instruments. However, you may want to obtain official certification through your supplier or local Weights & Measures office.

This **MT Xpress** product was developed, produced, and tested in a METTLER TOLEDO facility that has been audited and registered according to international ISO 9001 quality standards and ISO 14000 environment control program. Properly used and maintained, this product will provide years of accurate weighing. Handle it as you would any piece of fine electronic equipment.

Please READ this manual BEFORE operating or servicing this equipment. Follow the instructions carefully and save this manual for future reference.

We at **MT Xpress** want to make sure you received the product you expected. It is important to us that you are satisfied with your purchase. If there is anything we can help you with, or if you are not satisfied with either your product or the services received from the **Xpress** representative, let us know.

### How can you reach us?

## Xpress CUSTOMER CARE CENTER, USA

**24/7 Information and Support:** [www.mt.com/xpress](http://www.mt.com/xpress)  
[xpress@mt.com](mailto:xpress@mt.com)

**8 AM to 8 PM EST:** Toll Free: 1-866-MTXPRESS

**Xpress**  
Mettler-Toledo, Inc.  
60 Collegeview  
Westerville, OH 43081

**FCC APPROVAL**

**This device complies with part 15 of the FCC Rules. Operation is subject to the following two conditions: (1) this device may not cause harmful interference, and (2) this device must accept any interference received, including interference that may cause undesired operation.**

## CONTENTS

<b>SAFETY NOTICE</b> .....	<b>5</b>
<b>PREPARING THE SCALE FOR USE</b> .....	<b>6</b>
ENVIRONMENT .....	6
UNPACKING AND ASSEMBLY .....	6
<b>YOUR XPRESS SCALE AT A GLANCE</b> .....	<b>8</b>
DISPLAY .....	8
KEYPAD.....	8
CURSORS (LED) .....	8
<b>OPERATING YOUR SCALE</b> .....	<b>9</b>
ZERO.....	9
TARE .....	9
COUNTING .....	10
ACCUMULATION AND RECALL .....	11
ALARM .....	11
<b>SPECIAL MODES – SETUP MODE</b> .....	<b>13</b>
ENTERING SETUP MODE.....	13
FUNCTION OF THE KEYS .....	13
CONFIGURATIONS.....	13
<b>CLEANING AND MAINTAINING YOUR SCALE</b> .....	<b>14</b>
CLEANING AND MAINTENANCE .....	14
TROUBLESHOOTING .....	14
<b>SERVICING YOUR SCALE</b> .....	<b>15</b>
ENTERING SERVICE MODE .....	15
FUNCTION OF THE KEYS .....	15
CONFIGURATIONS .....	15
GRAVITY ADJUSTMENT .....	16
CALIBRATION .....	16
BATTERY REPLACEMENT.....	18
<b>APPENDIX</b> .....	<b>20</b>
ERROR MESSAGES.....	20
SPECIFICATIONS .....	21
GEO VALUE TABLE .....	22
PHYSICAL DIMENSIONS .....	23



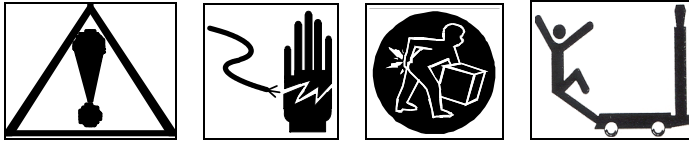

## SAFETY NOTICE



Product safety is a fundamental concern at MT Xpress. Use common sense and follow the simple precautions listed below to ensure your safety and to optimize the use and performance of this product.

- Read this manual before operating or servicing this product. Save this manual for future reference.
- Observe safety warnings located throughout this manual.
- Use caution when lifting or moving heavy equipment.
- This product should only be serviced by qualified personnel. Exercise care when moving, testing, or adjusting this product.
- Disconnect all power to this product before installing, servicing, or cleaning.
- Use only **MT Xpress** parts for repair.
- Observe electrostatic handling precautions for electronic components. Allow at least 30 seconds after power is disconnected to allow charges to dissipate before servicing any electronic components.
- Allow the product to adjust to room temperature before connecting the power source.

### Battery Notice

-  When 'Lo' appears in the display window, the battery must be recharged or replaced by a new one. When connecting to an AC power supply, the battery can be automatically recharged. The charging cursor is "on" above the battery charging symbol . The charging time is usually 12 hours. If the charging is complete, the cursor will be off.
-  Never invert the positive and negative poles of battery. The red terminal is for the positive pole , the black terminal is for the black plug.
-  The battery must be taken out when the scale is not used for long periods of time. The battery should be recharged at least once every three months.
-  Do not use another type of battery to replace the one supplied with the scale.

**FAILURE TO FOLLOW THESE PRECAUTIONS COULD RESULT IN DAMAGE TO OR DESTRUCTION OF THE EQUIPMENT, OR BODILY HARM.**

## PREPARING THE SCALE FOR USE

The **Xpress** XTCII is a new generation counting scale. With high internal and display resolution as well as a unique profile, the XTCII can widely be used in counting applications in the electronics, metals, plastics and other such industries. The **Xpress** XTCII is ready to use right out of the box.

This manual provides not only the detailed information on how to operate the scale, but also useful messages for service and maintenance.

Please read the manual thoroughly and familiarize yourself with all the safety requirements. All service procedures must only be performed by authorized personnel.

This chapter gives detailed instructions and important information regarding the successful installation of the **Xpress** Economy Counting Scale.

### **ENVIRONMENT**

Before you install the scale, identify the best location for the equipment. The proper environment enhances its operation and longevity. Keep in mind the following factors, which might have a negative influence on the scale's operation:

**Vibration:** Vibration diminishes the scale's ability to measure accurately. Electrical machinery such as conveyors and drill presses can cause inaccurate and non-repeatable readings. The scale may also read inaccurately if it is not leveled properly.

**Air currents:** Moving air can cause the scale to read wind movement as an additional force and cause inconsistency in the weighing results.

**Friction:** A scale cannot measure accurately if an object is rubbing or pressing against the scale platform.

### **UNPACKING AND ASSEMBLY**

Please inspect the package immediately upon receipt. If the box is damaged, check for internal damage and file a freight claim with the carrier if necessary. If the container is undamaged, open the box, remove the scale and place it on a solid, flat surface. Please keep the packing material and shipping insert in case you need to return the scale to an MT Xpress representative.

Package contents for all **Xpress** Economy Counting Scales include:

#### Product

- XTCII Counting Scale
- Scale Pan
- Adapter 9 V / 500 mA
- Rubber gasket (4 pieces, only for 6 lb and 15 lb scale)
- Lead seal wire and lead

#### Documents

- Quick Start Guide
- Installation Instructions

#### CD-ROM

- Operation & Service Manual

1. Place the scale on a flat surface.
2. Remove the protective screws (only for the 6 lb and 15 lb scales)

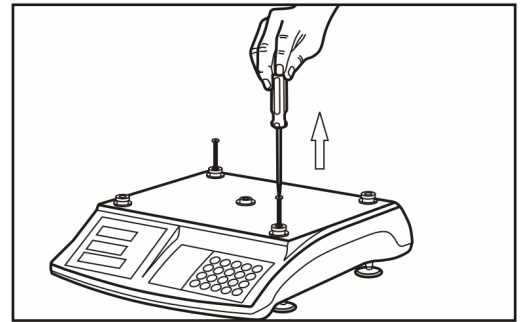

3. Mount four rubber gaskets onto each spider foot (only for the 6 lb and 15 lb scale).

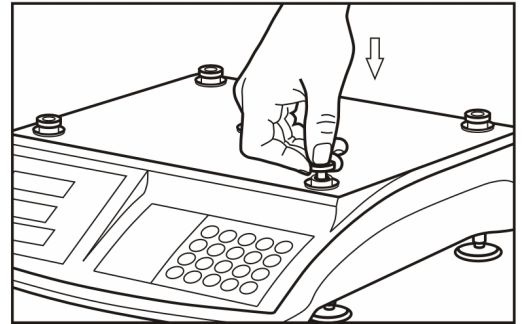

4. Put the platter on the spider (aluminum plate). Ensure that the platter is properly aligned.
5. Connect the scale to the power outlet using the included adapter.

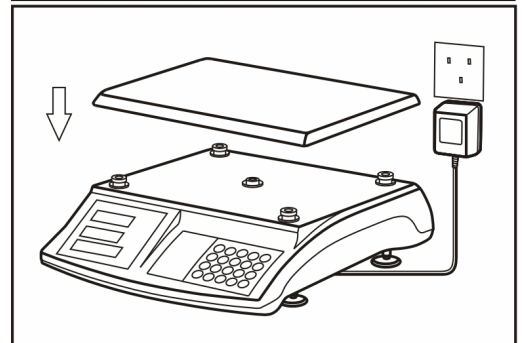

6. Level the scale by adjusting the four rubber feet until the leveling bubble is centered in the level indicator.

Proper alignment    Improper alignment



7. Turn on the scale.
8. The scale should be running for about fifteen (15) minutes before operation.

The windows display from 0-9, the software version No. and `----`.  
The cursors of stab and 0 are on.

## YOUR XPRESS SCALE AT A GLANCE

### DISPLAY

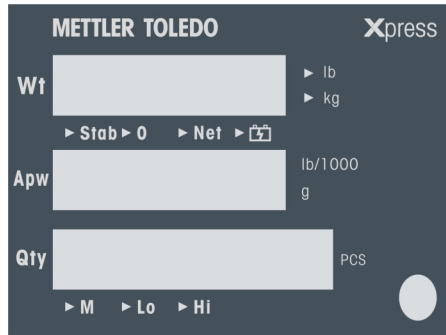

### KEYPAD

Key	Name	Function
	Decimal	Enters a decimal point/Toggles alarm beep
thru	Numeric	Data entry (0-9)
	Sample	Initiates sampling
	APW	Initiates Average Piece Weight (APW) entry
	Zero	Zeroes the scale
	Tare	Subtracts tare value and switches from gross to net mode
	Accumulation	Adds the accumulator counts or recalls accumulation
	Recall	Recalls the accumulated quantity and times
	Alarm	Sets the range for quantity or weight alarms
	Clear	Clears data from the display
	Enter/Setup	Confirms an operation or enters Setup Mode

### CURSORS (LED)

Key	Description
	Is lit when the weighing data is stable
	Is lit when the scale is at gross zero
	Is lit when the scale displays a net weight
	Is lit when the battery is being charged
	Is lit when the value in the accumulator is <i>not</i> zero
	Is lit when weight/quantity is less than the lower limit of alarm range
	Is lit when weight/quantity exceeds the upper limit of alarm range



## OPERATING YOUR SCALE

### ZERO

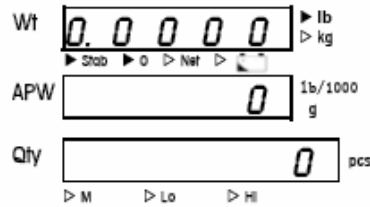
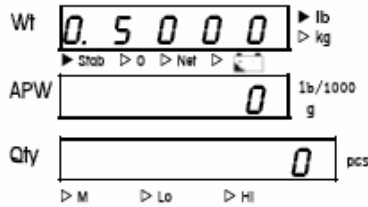

Press  $\rightarrow 0 \leftarrow$  to capture a new center of zero if the scale is in gross weight mode and the weight on the scale is stable (e.g. 0.5000 lb, as above shown, the cursor 'Stab' is on). The cursor "0" is lit when a new center of zero is captured.

### TARE

Pressing the  $\rightarrow T \leftarrow$  key subtracts the weight of the object on the scale platform from subsequent indications of weight. Tare is most often used to subtract the weight of an empty container. The  $\rightarrow T \leftarrow$  key is used as well to clear a previously entered tare value if the scale is in net mode.

#### Direct Tare

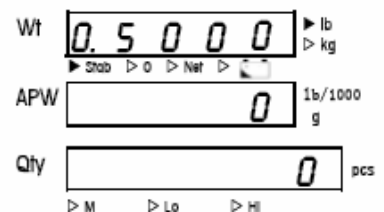
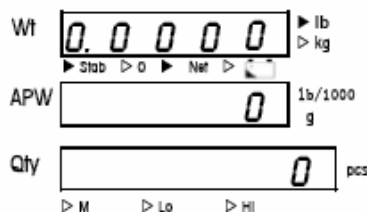
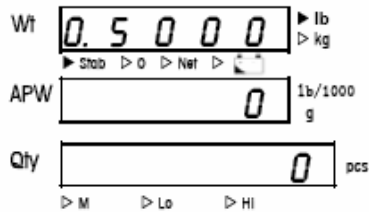

Press the key  $\rightarrow T \leftarrow$  in gross weight mode when the weight on the scale is above zero (e.g. 0.5000 lb as above shown) to tare the scale. If a net center of zero can be captured, the cursor 'Net' is on. By pressing the key  $\rightarrow T \leftarrow$  again, the scale will be back in gross weight mode. The tare range is the full capacity of the scale.

#### Input Tare (Digit Tare)

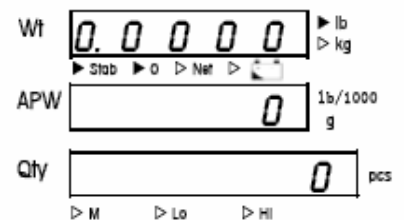
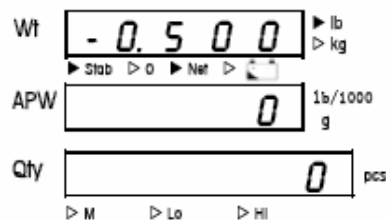
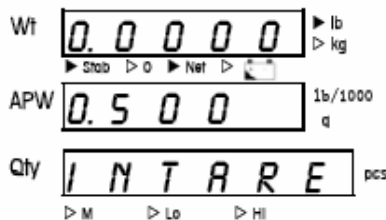

If the Function F3 in the Setup Mode is set to 1 (F3=1, see Setup Mode), the scale can be tared manually without weighing-in the tare value. Press the key  $\rightarrow T \leftarrow$  to enter a tare value. The QTY window displays "InTare" to remind you to enter the tare. The input tare is displayed in the APW window and can be corrected by pressing the key  $\odot$  if a wrong figure is entered. By pressing the key  $\rightarrow \oplus \leftarrow$ , you confirm the input tare value. The display shows the negative tare value in the weight window with the cursor "Net" on.

The input tare can be cleared by pressing the key  $\rightarrow T \leftarrow$  again, and the scale is then back to gross weight mode.

**COUNTING**

**Counting by Sampling**

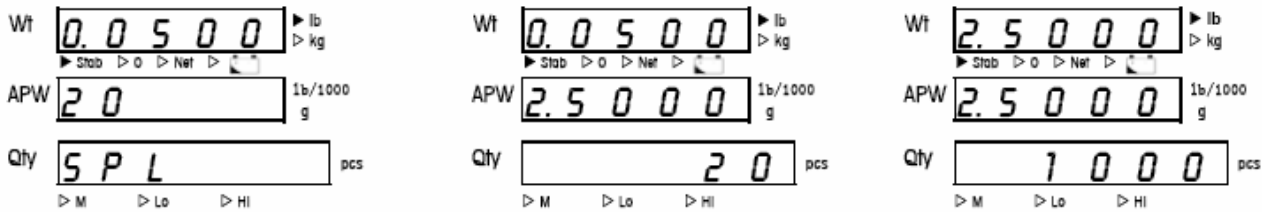

Place the samples on the platter (e.g. 20 pieces weights 0.05 lb as shown above). Press the key **SPL** to sample. The QTY window displays SPL. Enter the sample quantity 20, and then press the key **[+]** to confirm.

Press the key **C** to correct or clear the input figure.

The **Wt** window displays the sample Weight; the **APW** window displays Average Piece Weight of samples and the **QTY** displays the sample Quantity.

**APW Enhancement**

The APW (Average Piece Weight) enhancement can be activated in the Setup Mode (F5=1). This enhancement is used to get a more accurate APW. After a sampling is complete, the scale will automatically re-calculate the APW. However, the added quantity of pieces should be less than the quantity on the scale. The scale gives a 'beep' after every APW enhancement. The function is always available unless the added quantity of pieces is more than that the quantity on the scale.

For example:

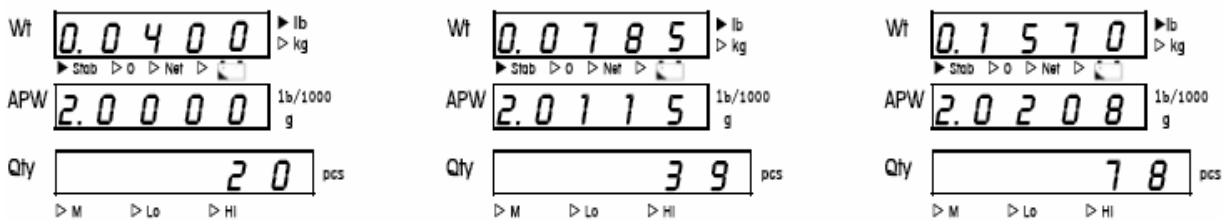

Sampling with 20 pieces that weight 0.04 lb and an APW 0.002 lb.

If you add another 19 pieces to the scale ( $\leq 20$  pcs), a beep indicates that the APW is automatically recalculated to 0.0020115 lb.

If you add another 39 pieces to the scale ( $\leq 39$  pcs), again, a beep indicates that the APW is automatically recalculated to 0.0020208 lb.

If you know the APW. . .

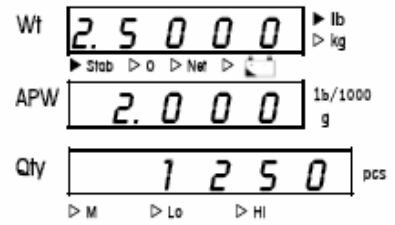
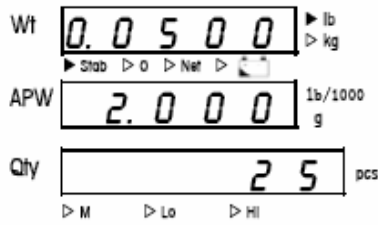
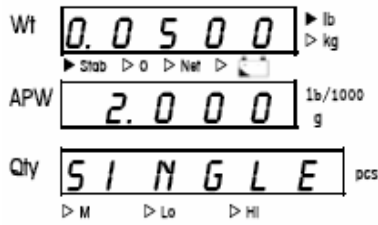

If you know the APW of your goods, the APW can be entered directly instead of sampling. Place the goods on the scale (e.g. 0.05 lb). Press the key **APW** and enter the APW (e.g. 0.002 lb) of one piece. The QTY window displays "Single" and the entered APW is displayed in the APW window. Press **Enter** to confirm. The QTY window displays now the total quantity of pieces (e.g. 25).

You may press the key **C** to correct or clear the input figure.

**ACCUMULATION AND RECALL**

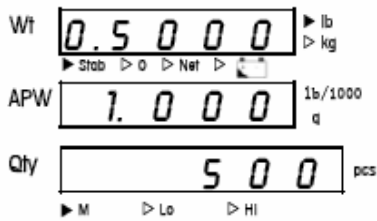
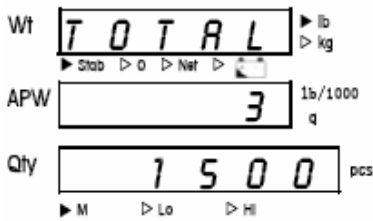

The key **M+** can be used to keep the quantity in the memory. The cursor 'M' is lit when the accumulated quantity is not zero. The Wt window displays 'Total' and the APW window displays accumulation times (e.g. 3 times). The QTY window displays the accumulated quantity (e.g. 1500 pcs).

Press **Enter** to confirm, then the quantity of goods on the scale into memory (e.g. 500 pcs).

To clear the accumulation, press **C** and the cursor "M" will be off.

Press **MR** to recall the total quantity and accumulation times (e.g. 2000 pcs, 4 times). Press **Enter** to exit recall.

When the accumulated quantity is above 999,999, the QTY window displays "nnnnnn" to indicate that maximum number of accumulations has been reached.

If the weight on the scale hasn't been changed between two accumulations, the QTY window will display 'Again' to refuse the operation.

**ALARM**

The alarm function includes a weight and a quantity alarm. Both alarms can either be set to sound within a defined range or over/under a defined range. The alarm function can be activated in the Setup Mode (F4/F4.1/F4.2/F4.3).

### Temporarily Disable the Alarm Beep

For all functions, the alarm beep can be deactivated by pressing the key . Pressing again will reactivate the alarm beep.

### Weight Alarm within a Range

If weight alarm within a range is activated in the Setup Mode, press the key to set the alarm range. The QTY window displays 'Lo 1' to remind you to enter the lower limit of the alarm range. The entered lower range is displayed in the APW window (e.g. 0.500 lb). Press the key to confirm the lower limit. The QTY window now displays 'Hi 1' to remind you to enter the upper limit of the alarm range (e.g. 1.000 lb). Press to complete the alarm range setting.

If the weight on the scale is within the alarm range (e.g. 0.800 lb on the scale, i.e.  $\geq 0.500$  lb and  $\leq 0.1000$  lb), the scale will beep continuously, and the cursors "Lo" and "Hi" will be lit. If the weight on the scale is less than the lower limit, the cursor 'Lo' will be on. The 'Hi' is on when the weight is higher than the upper limit.

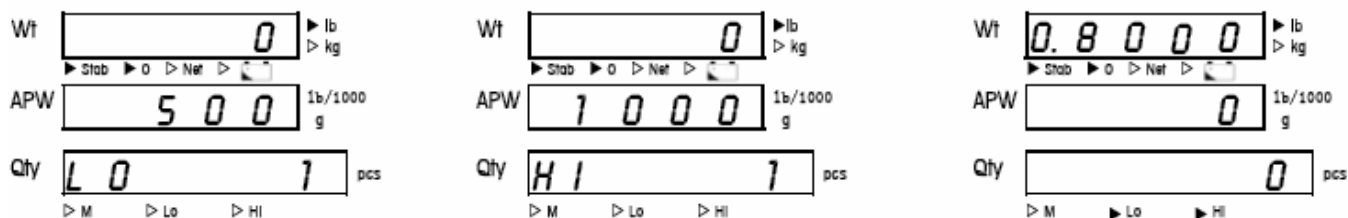

### Weight Alarm beyond a Range

If weight alarm beyond a range is activated in the Setup Mode, press to set the alarm range. The QTY window displays 'Lo 1' to remind you to enter the lower limit of the alarm range. The entered lower range is displayed in the APW window (e.g. 0.5 lb). Press to confirm the lower limit. The QTY window now displays 'Hi 1' to remind you to enter the upper limit of alarm range (e.g. 0.1000 lb). Press to complete the alarm setting. If the weight on the scale is beyond the alarm range (e.g. 1.200 lb on the scale, i.e.  $< 0.500$  lb or  $> 0.1000$  lb) the scale will beep continuously. The cursor "Lo" will be on if the weight on the scale is less than the lower limit. The 'Hi' cursor is on when the weight is higher than the upper limit.

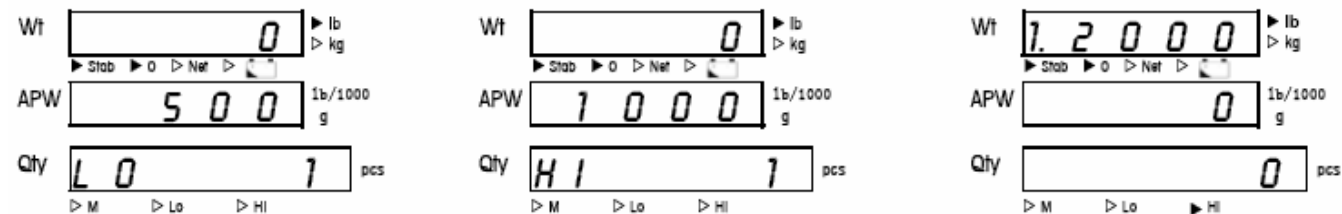

### Quantity Alarm

The two quantity alarms (within a range/beyond a range) work the same way as the weight alarms. Instead of "Lo 1" and "Hi 1", "Lo 2" and "Lo 2" are indicated.



## SPECIAL MODES – SETUP MODE

### ■ ENTERING SETUP MODE

Press and hold  for three seconds to enter the Setup Mode. If you change the display resolution in the Setup Mode, the scale will perform its power-up process after exiting the Setup Mode. If the resolution remains unchanged, the scale will return to its previous state.

### ■ FUNCTION OF THE KEYS

In the Setup Mode, the functions of the keys will be as follows:

Key	Function	Description
	Select	Switches between the parameters of 1 and 0
	Next	Confirm the choice and move forward
	Previous	Confirm the choice and steps backward

### ■ CONFIGURATIONS

Display	Parameter	Default
F1	Weighing unit 0 - weighing unit: lb 1 - weighing unit: kg	0
F2	Display resolution 0 - 3000 (6 lb=3000; 15 lb=3000; 30 lb=3000; 60 lb=3000) 1 - 6000/7500 (6 lb=6000; 15 lb=7500; 30 lb=6000; 60 lb=6000) 2 - 12,000/15,000 (6 lb=12,000; 15 lb=15,000; 30 lb=15,000; 60 lb=12,000) 3 - 30,000 (6 lb=30,000; 15 lb=prohibited; 30 lb=30,000; 60 lb=30,000)	2
F3	Input an advance fare 0 - disabled 1 - enable	0
F4	Alarm parameter change 0 - do not enter the alarm sub-menu 1 - enter the alarm sub-menu <b>Note:</b> If F4 is set 0, the scale will directly enter F5.	0
F4.1	Alarm function 0 - alarm is disabled 1 - alarm is available	0
F4.2	Weight alarm or quantity alarm 0 - weight alarm 1 - quantity alarm	0
F4.3	Alarm mode select 0 - alarm within a range 1 - alarm beyond a range	0
F5	APW enhancement 0 - disabled 1 - activated	0
F6	Automatic sleep 0 - disabled 1 - automatic sleep after 5 minutes if the weight on scale is not changed	0
F7	Zero capture range 0 - 0d 1 - 1d 2 - 2d 3 - 3d 4 - 4d 5 - 5d	3
F8	Push button zero range 0 - 20 % FS 1 - 2 % FS	0
E	Exit/Save 0 - do not save the change 1 - save the changes	

## CLEANING AND MAINTAINING YOUR SCALE



### **CLEANING AND MAINTENANCE**

- DO NOT allow untrained personnel to operate, clean, inspect, maintain, service, or tamper with this equipment.
- DO NOT attempt to remove the cover or to perform service/maintenance on the internal parts of the scale.
- ALWAYS DISCONNECT this equipment from the power source before cleaning or performing maintenance.
- KEEP the scale clean. Periodically clean the keyboard and cover with a soft clean cloth that has been dampened with a mild window cleaner or detergent. DO NOT USE ANY TYPE OF INDUSTRIAL SOLVENT OR CHEMICALS. DO NOT SPRAY CLEANER DIRECTLY ONTO THE UNIT.
- DO NOT put the scale under water. You may use a damp cloth to clean the scale.

### **TROUBLESHOOTING**

If operational difficulties are encountered, first obtain as much information as possible regarding the problem. Failures and malfunctions can often be traced to simple causes such as loose connections, low battery power, or improper setup.

Your authorized **Xpress** representative can perform additional troubleshooting.

## SERVICING YOUR SCALE

 For the following services, please contact your Xpress representative at [www.mt.com/xpress](http://www.mt.com/xpress).



**WARNING**

DISCONNECT ALL POWER TO THIS UNIT BEFORE INSTALLING, SERVICING, CLEANING, OR REMOVING THE FUSE. FAILURE TO DO SO COULD RESULT IN BODILY HARM AND/OR PROPERTY DAMAGE.

**CAUTION**

BEFORE CONNECTING OR DISCONNECTING ANY INTERNAL ELECTRONIC COMPONENTS OR INTERCONNECTING WIRING BETWEEN ELECTRONIC EQUIPMENT, ALWAYS REMOVE POWER AND WAIT AT LEAST THIRTY (30) SECONDS BEFORE ANY CONNECTIONS OR DISCONNECTIONS ARE MADE. FAILURE TO OBSERVE THESE PRECAUTIONS COULD RESULT IN DAMAGE TO OR DESTRUCTION OF THE EQUIPMENT, OR BODILY HARM.



### ENTERING SERVICE MODE

In the Service Mode, calibration and other system parameter settings can be accessed. In order to enter the Service Mode short the contacts of the switch J3. J3 is located on the upper side of the PCB, where the keypad cable and the main PCB are connected.

After access of calibration, the Wt window displays S1 0. Then assemble the scale to enter set up as follows.

### FUNCTION OF THE KEYS

In the Service Mode, the functions of the keys will be as follows:

Key	Function	Description
	Select	Switches between the parameter 1 and 0
	Next	Confirms the choice and moves forward
	Previous	Confirms the choice and steps backward

### CONFIGURATIONS

Display	Parameter	Default
S1	Display mode 0- normal display 1- advanced display	0
S2	Calibration units 0- lb 1- kg	0
S3	GEO code setting 0- not setting 1- Resetting	0
S4	Enter calibration sub-menu 0- no 1- yes	0
S4.1	Calibration mode select 0- full range calibration 1- linearity calibration	0
E	Save changes 0- exit without saving 1- save changes	0

## GRAVITY ADJUSTMENT

This scale has built-in compensation provisions to allow factory calibration, with destination correction capabilities, to compensate for variances on gravitational forces. If the scale is subjected to a different gravitational force at its destination location, this can be compensated for electronically by adjusting the geo value. The GEO value has 32 settings. The GEO value for any world location can be found in the GEO Value Table in the Appendix of this manual (See page 19.) as long as the geographical coordinates and elevation above sea level is known.

Select S3=1 and press to enter the GEO sub-menu. The GEO value can be changed as shown below by pressing .

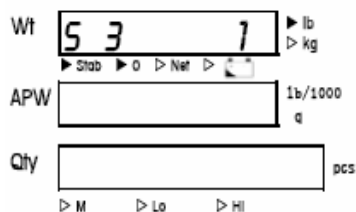

## CALIBRATION

To enter the calibration sub-menu, select S4=1. The scale can be calibrated in two modes, the full range calibration and the linearity calibration.

**Example: 6 lb full range calibration (S4.1=0)**

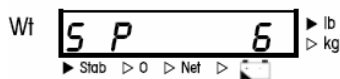

The scale displays SP 6, where 6 means the capacity is 6 lb. Pressing can select the capacity. Press the key to continue.

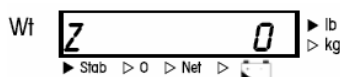

The Wt window displays Z 0. Press to capture zero weight; the scale counts down from 5. Press to next step.

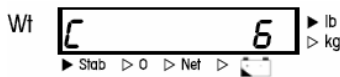

The Wt window displays C 6. Put 6lb weight on the scale. Press the key to calibrate. The scale counts down from 5.

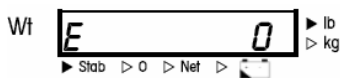

Display E 0 and press to switch to E 1. Press to save the result. The calibration is complete and the scale restarts.



**Example: 6 lb linearity calibration (S4.1=1)**

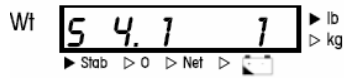

When the Wt window display S4.1 1, press the key to calibrate the scale in linearity.

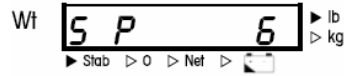

The scale displays SP 6, where 6 means the capacity is 6 lb, Pressing selects the capacity. Press to continue.

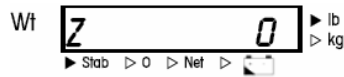

The Wt window displays Z 0. The scale will capture zero weight by pressing the key . The scale should count down from 5. Press the key to proceed to the next step.

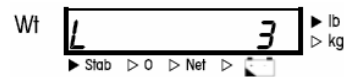

The Wt window displays L 3. Put 3 lb weight on the scale, press to calibrate in half range. The scale counts down from 5.

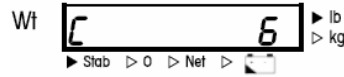

Remove the weight on the scale. The Wt window displays C 6. Put 6 lb weight on the scale. Press to calibrate in half range. The scale should count down from 5.

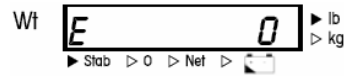

Display E 0. Press to save the result. The calibration is complete and the scale restarts.

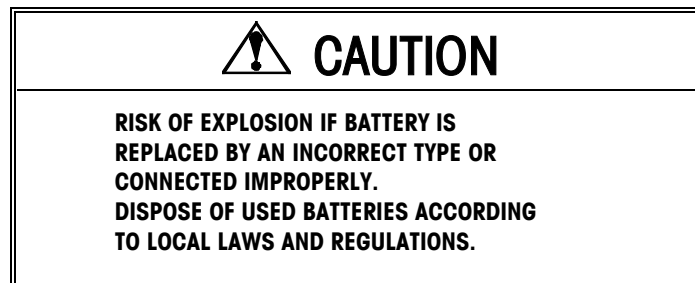
**BATTERY REPLACEMENT**

Please replace the battery follow below steps:

1. Switch off the scale.
2. Open and remove the plastic battery cover on the rear of the XTCII.

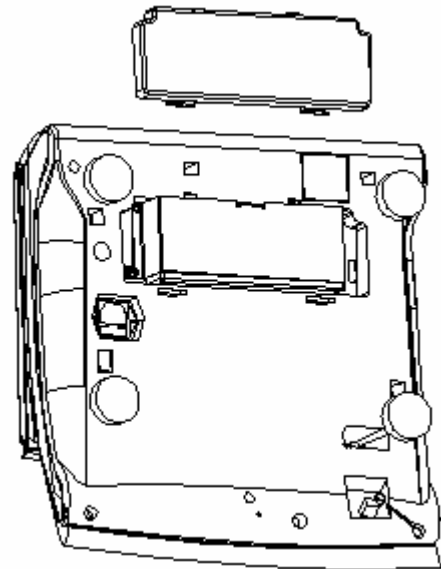

3. Loosen the four M4 x 8 screws and remove the protective cover.

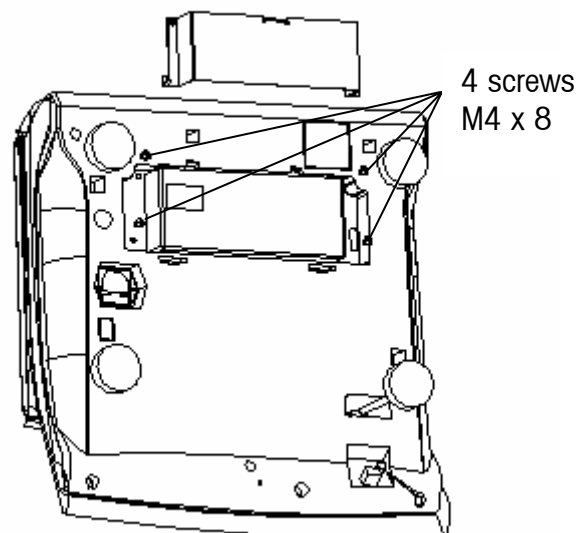

- Carefully remove the power harness from the battery, replace a new battery and connect the terminal to the plug correctly.

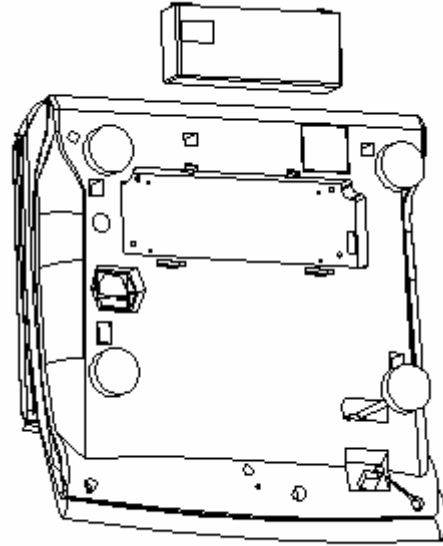
**CAUTION**

RISK OF EXPLOSION IF BATTERY IS REPLACED WITH WRONG TYPE OR CONNECTED IMPROPERLY. CONNECT RED WIRE TO POSITIVE (+) BATTERY TERMINAL AND BLACK WIRE TO NEGATIVE (-) BATTERY TERMINAL!

- Reinstall the protective cover and the plastic battery cover.
- Switch on the scale and test for proper operation.

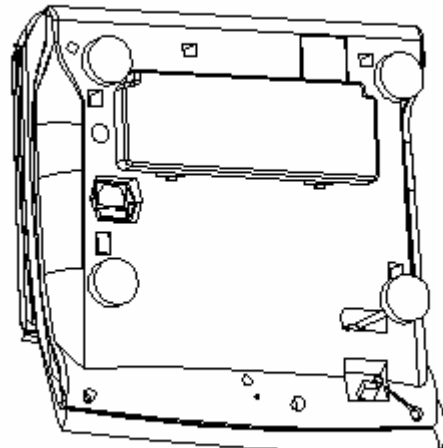

## APPENDIX

### ERROR MESSAGES

The scale will display an error message if a problem or an incorrect keyboard entry is sensed. The error codes are:

Display	Possible Cause	Troubleshooting
The Wt window displays E11	RAM error	<ol style="list-style-type: none"> <li>1. Restart the scale.</li> <li>2. Recalibrate the scale.</li> <li>3. Change the main PCB.</li> </ol>
The Wt window displays E16	ROM error	<ol style="list-style-type: none"> <li>1. Restart the scale.</li> <li>2. Recalibrate the scale.</li> <li>3. Change the main PCB.</li> </ol>
The Wt window displays E18/E3	EPROM checksum error	<ol style="list-style-type: none"> <li>1. Restart the scale.</li> <li>2. Recalibrate the scale.</li> <li>3. Change the main PCB.</li> </ol>
The Wt window displays E7	A/D convert error	Change the main PCB.
The Wt window displays E35	Less weight when calibration	Recalibrate the scale with a specified weight.
The Wt window displays "nnnnn"	Over capacity	Take away some weight
The Wt window displays "uuuuu"	Under capacity	<ol style="list-style-type: none"> <li>1. Put the scale pan on.</li> <li>2. Press the key  to zero scale.</li> </ol>
The QTY window displays "nnnnnn"	Quantity is over 999,999	Clear the accumulator.
-----	Cannot capture zero	<ol style="list-style-type: none"> <li>1. Restart the scale with no weight.</li> <li>2. Recalibrate the scale.</li> <li>3. Change the load cell or main PCB.</li> </ol>

## SPECIFICATIONS

Model	XTCII-1003	XTCII-1103	XTCII-2003	XTCII-2103	XTCII-3003	XTCII-3103	XTCII-4003	XTCII-4103
Maximum capacity (lb)	6		15		30		60	
Verified resolution (lb)	0.002		0.005		0.01		0.02	
Display resolution (lb)	0.0002, 0.0005, 0.001, 0.002		0.001, 0.002, 0.005		0.001, 0.002, 0.005, 0.01		0.002, 0.005, 0.01, 0.02	
Recommend minimum APW (lb)	0.0002		0.0004		0.001		0.002	
Power supply	AC	AC/DC	AC	AC/DC	AC	AC/DC	AC	AC/DC
Shipment weight (lb)	11	13.2	11	13.2	11	13.2	11	13.2
Display	Red LED							
Temperature range	5°C - 35°C							
Relative humidity	< 90%							
Pan size	13.5" x 9.5" (L x W)							
Scale size	13.6" x 14" x 4.5" (L x W x H)							
Package size	18.3" x 16.5" x 8.7" (L x W x H)							

Power supply DC uses 6V, 5Ah rechargeable battery.

Specifications are subject to change without notice.

**GEO VALUE TABLE**

Use the following geo codes if you relocate your scale to a site other than the original location where it was calibrated.

Northern and Southern latitude in degrees and minutes	Height above sea-level in meters										
	0 325	325 650	650 975	975 1300	1300 1625	1625 1950	1950 2275	2275 2600	2600 2925	2925 3250	3250 3575
	Height above sea-level in feet										
	0 1060	1060 2130	2130 3200	3200 4260	4260 5330	5330 6400	6400 7460	7460 8530	8530 9600	9600 10,660	10,660 11,730
0° 0' — 5° 46'	5	4	4	3	3	2	2	1	1	0	0
5° 46' — 9° 52'	5	5	4	4	3	3	2	2	1	1	0
9° 52' — 12° 44'	6	5	5	4	4	3	3	2	2	1	1
12° 44' — 15° 6'	6	6	5	5	4	4	3	3	2	2	1
15° 6' — 17° 10'	7	6	6	5	5	4	4	3	3	2	2
17° 10' — 19° 2'	7	7	6	6	5	5	4	4	3	3	2
19° 2' — 20° 45'	8	7	7	6	6	5	5	4	4	3	3
20° 45' — 22° 22'	8	8	7	7	6	6	5	5	4	4	3
22° 22' — 23° 54'	9	8	8	7	7	6	6	5	5	4	4
23° 54' — 25° 21'	9	9	8	8	7	7	6	6	5	5	4
25° 21' — 26° 45'	10	9	9	8	8	7	7	6	6	5	5
26° 45' — 28° 6'	10	10	9	9	8	8	7	7	6	6	5
28° 6' — 29° 25'	11	10	10	9	9	8	8	7	7	6	6
29° 25' — 30° 41'	11	11	10	10	9	9	8	8	7	7	6
30° 41' — 31° 56'	12	11	11	10	10	9	9	8	8	7	7
31° 56' — 33° 9'	12	12	11	11	10	10	9	9	8	8	7
33° 9' — 34° 21'	13	12	12	11	11	10	10	9	9	8	8
34° 21' — 35° 31'	13	13	12	12	11	11	10	10	9	9	8
35° 31' — 36° 41'	14	13	13	12	12	11	11	10	10	9	9
36° 41' — 37° 50'	14	14	13	13	12	12	11	11	10	10	9
37° 50' — 38° 58'	15	14	14	13	13	12	12	11	11	10	10
38° 58' — 40° 5'	15	15	14	14	13	13	12	12	11	11	10
40° 5' — 41° 12'	16	15	15	14	14	13	13	12	12	11	11
41° 12' — 42° 19'	16	16	15	15	14	14	13	13	12	12	11
42° 19' — 43° 26'	17	16	16	15	15	14	14	13	13	12	12
43° 26' — 44° 32'	17	17	16	16	15	15	14	14	13	13	12
44° 32' — 45° 38'	18	17	17	16	16	15	15	14	14	13	13
45° 38' — 46° 45'	18	18	17	17	16	16	15	15	14	14	13
46° 45' — 47° 51'	19	18	18	17	17	16	16	15	15	14	14
47° 51' — 48° 58'	19	19	18	18	17	17	16	16	15	15	14
48° 58' — 50° 6'	20	19	19	18	18	17	17	16	16	15	15
50° 6' — 51° 13'	20	20	19	19	18	18	17	17	16	16	15
51° 13' — 52° 22'	21	20	20	19	19	18	18	17	17	16	16
52° 22' — 53° 31'	21	21	20	20	19	19	18	18	17	17	16
53° 31' — 54° 41'	22	21	21	20	20	19	19	18	18	17	17
54° 41' — 55° 52'	22	22	21	21	20	20	19	19	18	18	17
55° 52' — 57° 4'	23	22	22	21	21	20	20	19	19	18	18
57° 4' — 58° 17'	23	23	22	22	21	21	20	20	19	19	18
58° 17' — 59° 32'	24	23	23	22	22	21	21	20	20	19	19
59° 32' — 60° 49'	24	24	23	23	22	22	21	21	20	20	19
60° 49' — 62° 9'	25	24	24	23	23	22	22	21	21	20	20
62° 9' — 63° 30'	25	25	24	24	23	23	22	22	21	21	20
63° 30' — 64° 55'	26	25	25	24	24	23	23	22	22	21	21
64° 55' — 66° 24'	26	26	25	25	24	24	23	23	22	22	21
66° 24' — 67° 57'	27	26	26	25	25	24	24	23	23	22	22
67° 57' — 69° 35'	27	27	26	26	25	25	24	24	23	23	22
69° 35' — 71° 21'	28	27	27	26	26	25	25	24	24	23	23
71° 21' — 73° 16'	28	28	27	27	26	26	25	25	24	24	23
73° 16' — 75° 24'	29	28	28	27	27	26	26	25	25	24	24
75° 24' — 77° 52'	29	29	28	28	27	27	26	26	25	25	24
77° 52' — 80° 56'	30	29	29	28	28	27	27	26	26	25	25
80° 56' — 85° 45'	30	30	29	29	28	28	27	27	26	26	25
85° 45' — 90° 00'	31	30	30	29	29	28	28	27	27	26	26

**PHYSICAL DIMENSIONS**

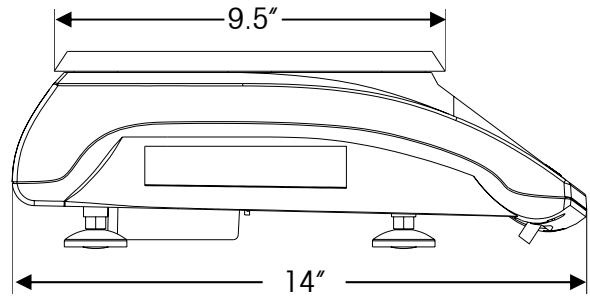
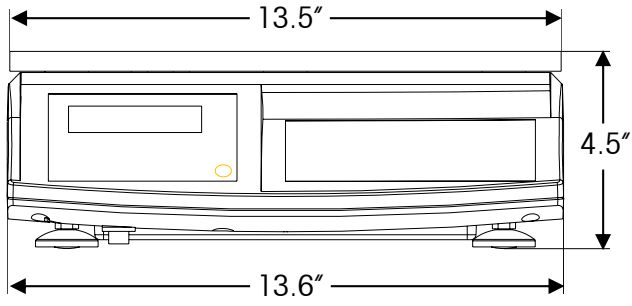

**Notes**



**Notes**

**Xpress**  
Mettler-Toledo, Inc.  
60 Collegeview  
Westerville, OH 43081

5/2004  
MTX04-OM015.1E

## ECONOMY COUNTING SCALE

## QUICK START GUIDE

Models XTCII

### DISPLAY

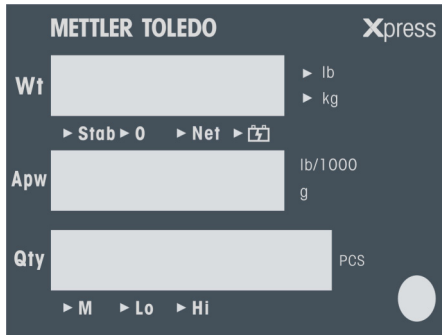

### KEYPAD

Key	Name	Function
	Decimal	Enters a decimal point/Toggles alarm beep
	Numeric	Data entry (0-9)
	Sample	Initiates sampling
	APW	Initiates Average Piece Weight (APW) entry
	Zero	Zeroes the scale
	Tare	Subtracts tare value and switches from gross to net mode
	Accumulation	Adds the accumulator counts or recalls accumulation
	Recall	Recalls the accumulated quantity and times
	Alarm	Sets the range for quantity or weight alarms
	Clear	Clears data from the display
	Enter/Setup	Confirms an operation or enters Setup Mode

### CURSORS (LED)

Key	Description
	Is lit when the weighing data is stable
	Is lit when the scale is at gross zero
	Is lit when the scale displays a net weight
	Is lit when the battery is being charged
	Is lit when the value in the accumulator is <i>not</i> zero
	Is lit when weight/quantity is less than the lower limit of alarm range
	Is lit when weight/quantity exceeds the upper limit of alarm range

### ZERO

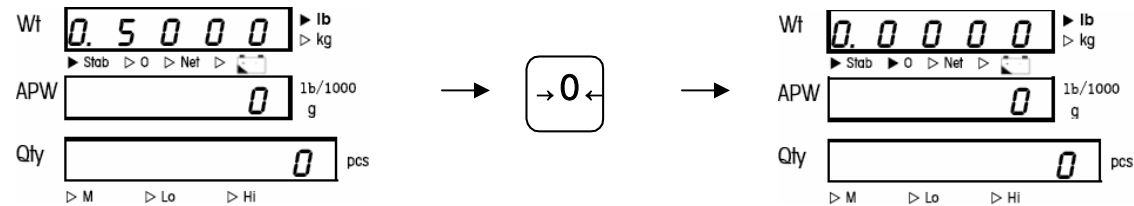

### TARE

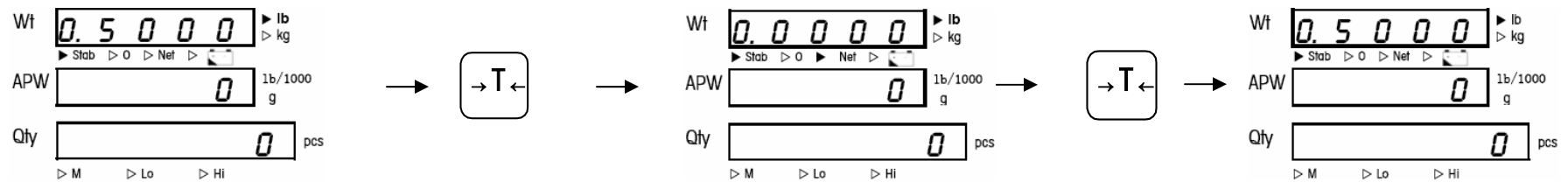

### SAMPLING (20 PIECES)

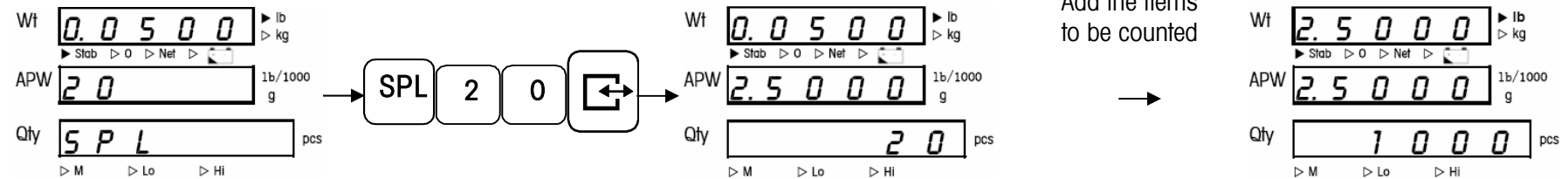

### INPUT AN KNOWN AVERAGE PIECE WEIGHT (APW e.g. 0.002 lb)

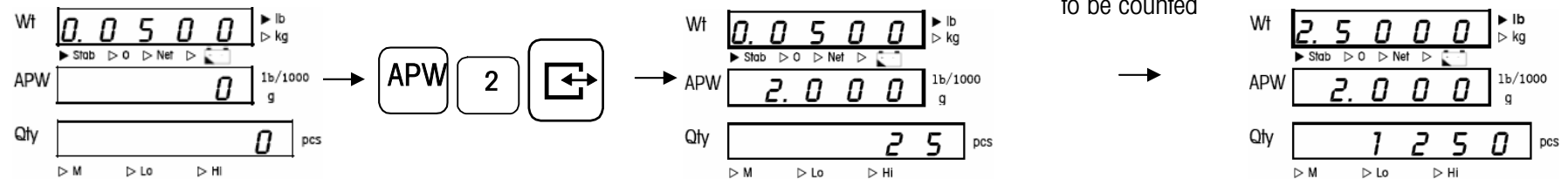

## ECONOMY COUNTING SCALE

## INSTALLATION INSTRUCTIONS

Models XTCII

### UNPACKING

Thank you for purchasing an **MT Xpress** product. Please inspect the package immediately upon receipt. If the box is damaged, check for internal damage and file a freight claim with the carrier if necessary.

If the container is undamaged, open the box, remove the scale and place it on a solid, flat surface.

Please keep the packing material and shipping insert in case you need to return the scale to an **Xpress** representative.

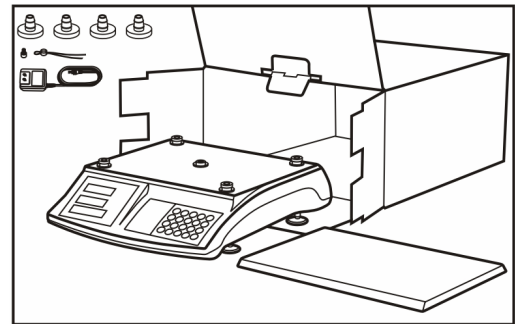

Package contents for all **Xpress** Standard Compact Scales include:

#### Product

- XTCII Counting Scale
- Scale Pan
- Adapter 9V / 500mA
- Rubber gasket (4 pieces, only for 6 lb and 15 lb scale)
- Lead seal wire and lead

#### Documents

- Quick Start Guide
- Installation Instructions

#### CD-ROM

- Operation & Service Manual

### ASSEMBLY

1. Place the scale on a level surface.
2. Remove protective screws (only for 6 lb and 15 lb scale)
  
3. Mount four rubber gaskets onto each spider foot (only for 6 lb and 15 lb scale)

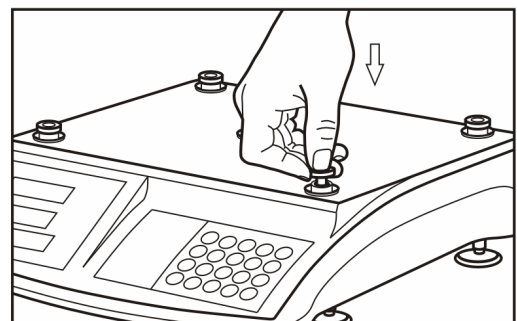
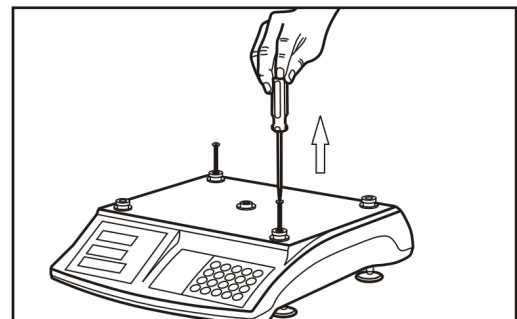

- Put the platter on the spider (aluminum plate). Ensure that the platter is properly aligned.
- Connect the scale to the power outlet using the included adapter.

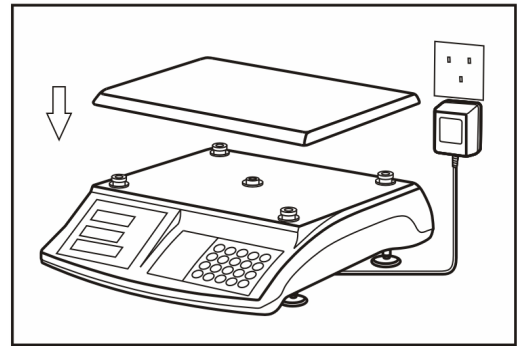

- Level the scale by adjusting the four rubber feet until the leveling bubble is centered in the level indicator.

Proper alignment    Improper alignment



- Turn on the scale
- The scale should be running for about fifteen (15) minutes before operation.

The windows display from 0-9, the software version number and `----`. The cursors of stab and 0 are on.

For detailed product information, please consult the Operation & Service Manual provided on the CD-ROM.

### **CUSTOMER SERVICE**

We at **MT Xpress** want to make sure you received the product you expected. It is important to us that you are satisfied with your purchase. If there is anything we can help you with, or if you are not satisfied with either your product or the services received from the **MT Xpress** representative, let us know:

**24/7 Information and Support:**

[www.mt.com/xpress](http://www.mt.com/xpress)

[xpress@mt.com](mailto:xpress@mt.com)

**8 AM to 8 PM EST**

Toll Free: 1-866-MTXPRESS

### **Xpress**

Mettler-Toledo, Inc.

60 Collegeview

Westerville, OH 43081