



INSTRUCTIONS

-J03083

REV. 10-21-2003

Kit Number 52553-03

RIDER BACKREST RELEASE HANDLE REPLACEMENT KIT

General

This kit is designed to replace a broken rider backrest release handle on:

- 1997 and later Touring models fitted with Harley-Davidson Genuine Motor Accessory adjustable rider backrests, and
- the following motorcycles fitted with Harley-Davidson Genuine Motor Accessory seats with adjustable rider backrests.
 - 1994 and later Sportster® models,
 - 1996 and later Dyna models,
 - 2000 and later Softail® models (except FXSTD).

This kit contains the following items:

QTY	DESCRIPTION	PART NO.
1	Handle assembly, rider backrest release	Not sold separately
2	Screw, button head Torx®, #6-32 x 5/8 in., black	94243-03

NOTE

A Service Manual for your model motorcycle is available from any Harley-Davidson dealer.

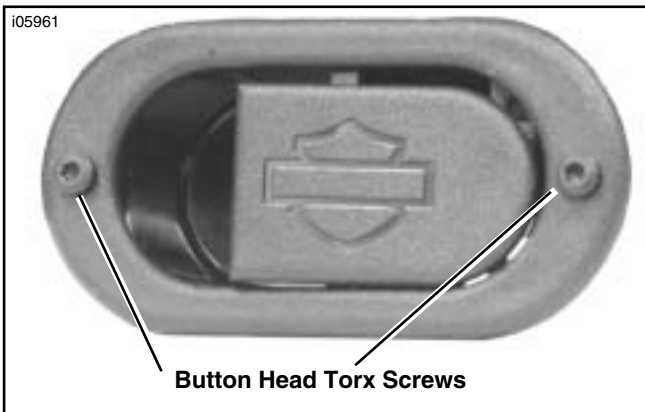

Figure 1. New Backrest Release Handle

Installation, Touring Models

NOTE

It will be helpful to have an assistant hold the backrest in the furthest back position during the attachment of the cable to the new handle.

1. Remove and discard the two Torx® screws from the plastic handle assembly.
Carefully pull the handle assembly, along with the cable, out of the mounting bracket. Disconnect the cable end pin from the handle and discard the handle.
2. With the backrest tilted as far back as it will go, use a needle-nose pliers to grasp the cable end, pulling it out of the handle opening as far as possible.

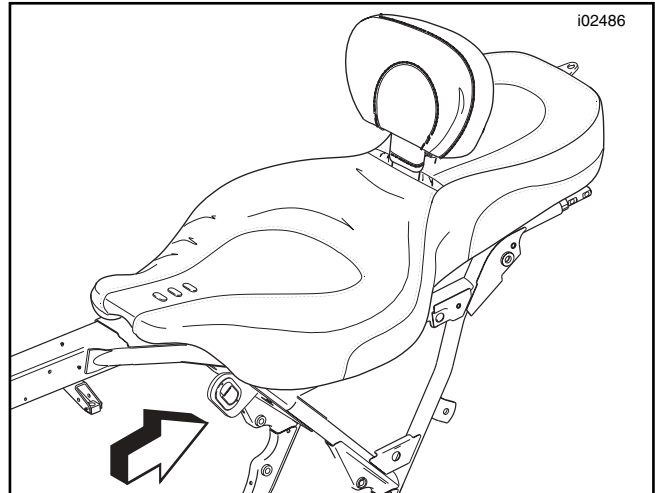

Figure 2. Backrest Release Handle Location, Touring Models

NOTE

For clarity, the illustrations greatly exaggerate the length of the cable extending from the opening. The cable will barely exit the bracket.

3. Position the new handle assembly alongside the handle bracket, with the cutout section facing upward and inward toward the seat.
4. Grasp the cable end pin as shown in Figure 3, and guide the pin down into the hole in the back of the release handle until the cable rests on the surface of the handle back.
5. See Figure 4. Rotate the pin to align the cable end with the vertical slot in the handle, then use a firm downward pressure to insert the cable and pin further into the hole and the vertical slot until the cable lines up with the horizontal slot (see Figure 5).

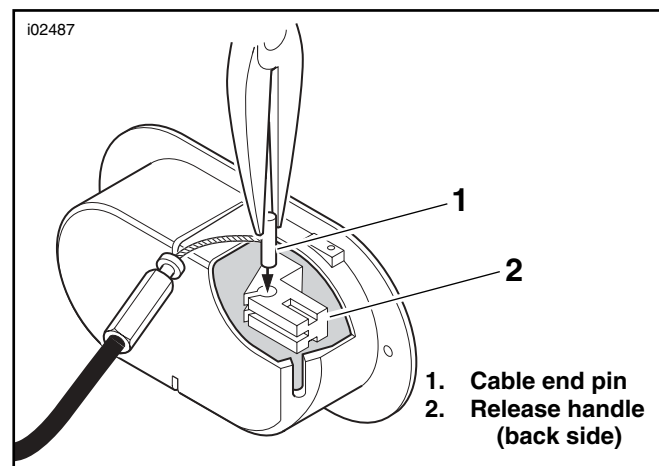

Figure 3. Insert Pin Into Hole In Release Handle

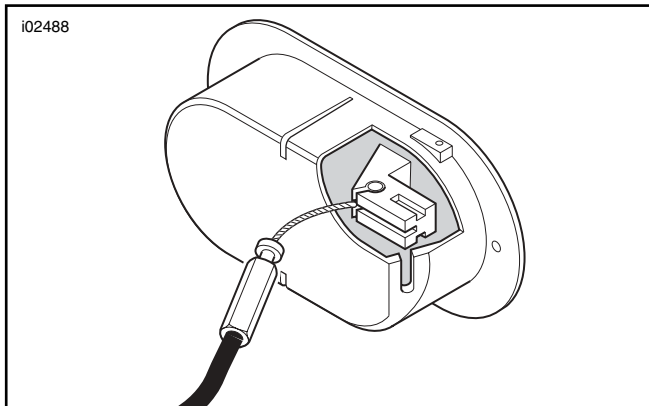

Figure 4. Pin Fully Inserted in Vertical Slot

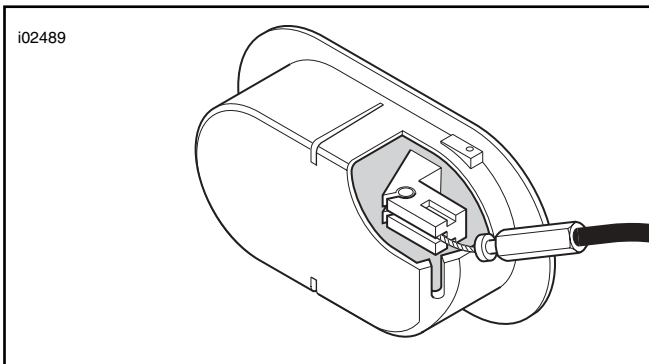

Figure 5. Rotate Cable Into Horizontal Slot

6. Capture the collar on the cable sheath in the slot of the new handle housing as shown in Figure 6. Push the collar into the slot as far as it will go.

NOTE

To avoid damage, avoid grabbing the cable with the pliers to pull it into the slot.

CAUTION

Be careful not to overtighten the Torx screws, or the plastic rim of the new backrest release handle may crack.

6. Insert the new handle, with the attached cable, back into the opening in the bracket. Firmly attach, but do not overtighten, with the two new button-head Torx screws from the kit.

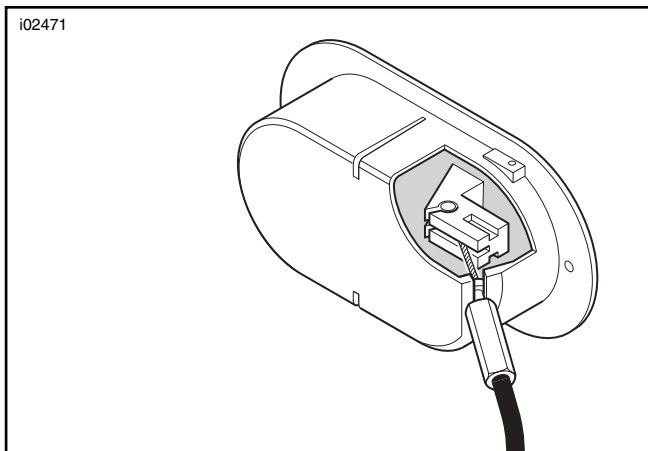

Figure 6. Cable Properly Installed In Handle

-J03083

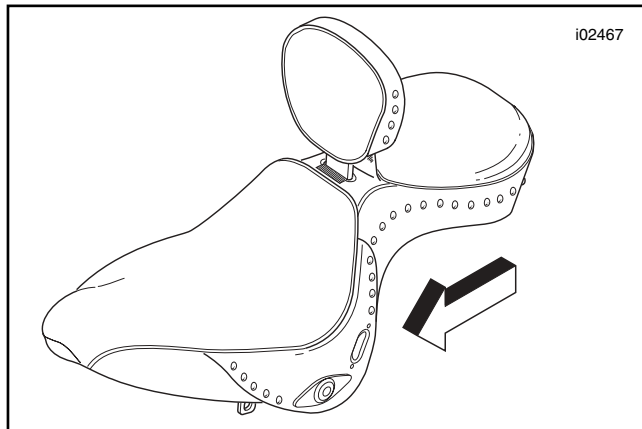

Figure 7. Backrest Release Handle Location, Sportster, Dyna and Softail Models

Installation, All Except Touring Models

NOTE

It will be helpful to have an assistant secure the seat with the backrest in the furthest back position during the attachment of the cable to the new handle.

1. Refer to the instruction sheet provided with your seat, or the Service Manual and follow the procedures given to remove the seat from the motorcycle. Remove and discard the two Torx® screws from the plastic handle assembly.

Carefully pull the handle assembly, along with the cable, out of the seat. Disconnect the cable end pin from the handle and discard the handle.

2. Lay a clean pad or blanket on the work surface to protect the seat upholstery. Place the seat upside-down on the work surface with the handle opening facing you.
3. While the upside-down seat is pressed down and forward to tilt the backrest as far back as it will go, use a needle-nose pliers to grasp the cable end, pulling it out of the handle opening as far as possible.

NOTE

For clarity, the illustrations greatly exaggerate the length of the cable extending from the opening. The cable will barely exit the seat.

4. Position the new handle assembly alongside the handle opening in the seat, with the cutout section facing upward and inward toward the seat.

Capture the collar on the cable sheath in the slot of the new handle housing as shown in Figure 8. Push the collar into the slot as far as it will go.

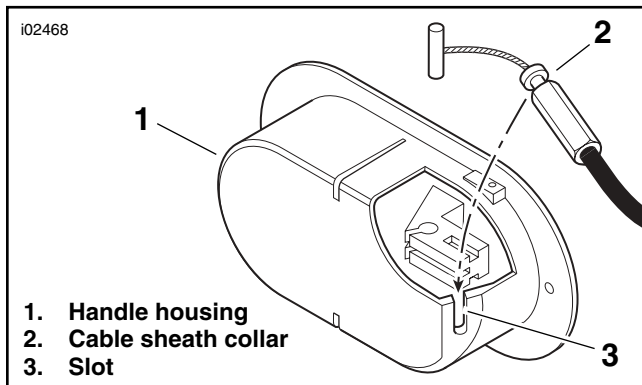

1. Handle housing
2. Cable sheath collar
3. Slot

Figure 8. Attach Cable to Handle Housing

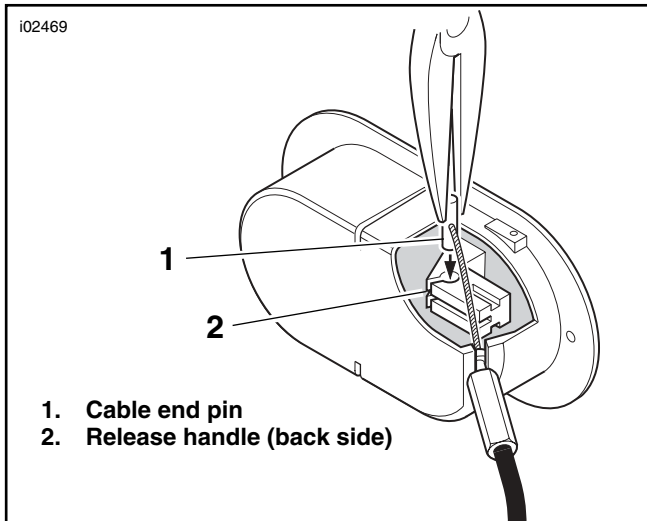

Figure 9. Insert Pin Into Hole In Release Handle

5. Use a (preferably offset) needle-nose pliers to grasp the cable end pin as shown in Figure 9, and guide the pin down into the hole in the back of the release handle until the cable rests on the surface of the handle back.

NOTE

To avoid damage, avoid grabbing the cable with the pliers to pull it into the slot.

6. See Figure 10. With a firm grip on the pin, rotate clockwise to align the cable end with the vertical slot in the handle, then use a firm downward pressure to insert the cable and pin further into the hole and the vertical slot until the cable snaps into the horizontal slot (see Figure 11).

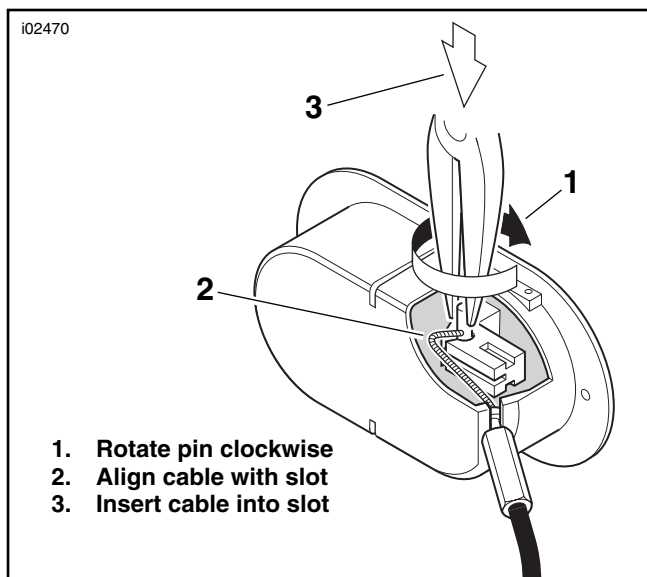

Figure 10. Rotate Cable Into Slot

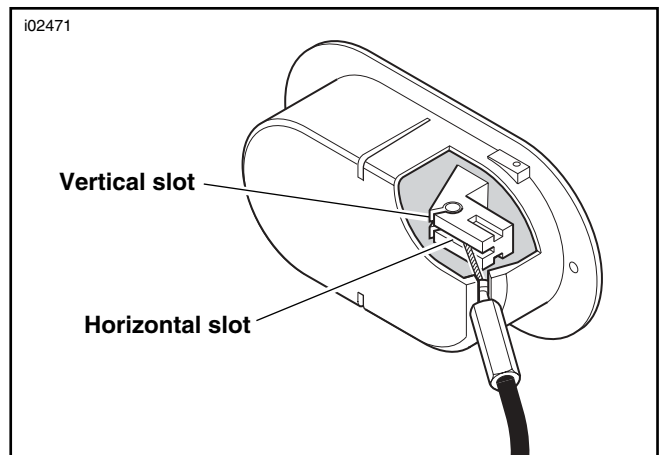

Figure 11. Cable Properly Installed In Handle

CAUTION

Be careful not to overtighten the Torx screws, or the plastic rim of the new backrest release handle may crack.

7. Insert the new handle, with the attached cable, back into the opening in the side of the seat. Firmly attach, but do not over-tighten, with the two new button-head Torx screws from the kit.
8. Refer to the instructions provided with your seat, or the Service Manual and follow the procedures given to re-install the seat.

WARNING

After installing seat, pull upward on front of seat to be sure it is in locked position. While riding, a loose seat can shift causing loss of control, which could result in death or serious injury. (00070a)