

BEEKO
COLOUR TELEVISIONS

L5A TFT-LCD TV
SERVICE MANUAL

CONTENTS

PAGES

Safety instructions	1
Technical specifications	2
Panel Specification	3
Chassis block diagram	4
Scaler block diagram	5
Block diagram of power supply	6
Chassis overview	7
Service mode items and explanations	12
Data sheet of important IC's	17
Recommended Part List	29
Frequency list of channels	30

SAFETY PRECAUTIONS

GENERAL GUIDELINES

1. Always use the manufacturer's replacement safety components. The critical safety components marked with ∇ on the schematics diagrams should not be by other substitutes. Other substitute may create the electrical shock, fire or other hazards. Take attention to replace the spacers with the originals. Furthermore where a short circuit has occurred, replace those components that indicate evidence of overheating.
2. After servicing, see that all the protective devices such as insulation barriers, insulation papers, shields and isolation R-C combinations are correctly installed.
3. When the receiver is not being used for a long time of period of time, unplug the power cord of the Adaptor from the AC outlet.

Color TFT LCD Module is very sensitive both electrically and physically. Users, therefore, are requested to follow the "Guidance of handling color TFT LCD Module" on the followings.

1 - Be careful not to make scratch on the polarizer.

Surface of polarizer is soft and can be physically damaged easily.
Please do not touch, push or rub polarizer surface with materials over HB hardness.

2 - Keep clean the surface.

Please wear rubber glove when touch the surface of LCD screen. Please use soft and anti-static material as cleaner.

3 - Keep out of water.

Water on/in the LCD may cause electrical short or corrosion. Please wipe out dry or water carefully.

4 - Prevent swift Temperature & Humidity change.

Instantaneous temperature and/or humidity change can make dew or ice which cause nonconformance such as malfunction.

5 High temperature & high humidity reduce the life-time.

LCD is not proper to be used at high temperature and high humidity. Please keep specified temperature and humidity condition.

6 - Keep out of Corrosive Gas.

Corrosive gas effect the polarizer and the circuit chemically and cause defects accordingly.

7 - Electrostatic discharge can make Damage

There are electro-static sensitive components such as CMOS in LCD Module. Please earth human body when handle the LCD. In addition, please do not touch the interface connector pin with bare.

8 - Do not operate for a long time under the same pattern

Operating LCD for a long time under the same pattern can cause image persistence and can damage it. Please follow following guidance.

1. Turn the power off when do not use.
2. Change the pattern periodically.

L5A TECHNICAL SPECIFICATION

Receiving System		PAL B/G+I+D/K SECAM L/L'
Comb Filter		Adaptive 4H\2H
Scaling		Upto SXGA at 75Hz
Gamma Correction		8 to 10-bit LUT
Histogram Equalization		YES
Stereo Decoding (German A2, Nicam, BTSC)		German A2, Nicam
Stereo L, R In		3
Stereo L, R Out		3
Audio Output Power RMS in Max at 10% THD)		2x3W, 2x5W for 22"W
Teletext	Level (1.5, 2.5, Teleweb)	Teletext 1.5
	Type (Fast\Top\Simple)	Simple, Fast, Top
	Page Memory	250p or 10p
WSS		+
VPS\PCD		+
Picture Formats (4:3, 16:9, 14:9, Panorama, LetterBox, Subtitle)	4:3	+
	16:9	+
	Panorama	+
	Letterbox	+
	Subtitle	+
WSS (Wide Screen Signalling)		+
ATS (Automatic Tuning System)		Frequency Search
Manual Search		Channel Table Search
Number of Program Storage		100
No Ident Timer		+
Picture Freeze		+
Equalizer		+
Zapping		+
AVL (Automatic Volume Level)		+
Sound Status Memory		+
Picture Status Memory		+
Swap		+
Child Lock		+
Program Lock		+
Picture Format Switching Thru Pin 8		+
Auto RGB Detect Thru Pin 16		+
PC Plug & Play (DDC\CI)		+
Timer	Off Timer (Sleep Timer)	+
	On Timer	+
Picture Smart (User, Soft, Natural, Rich)		+
Sound Smart (User, Music, Sports, Cinema, Speech)		+
Scart		2
S-video (DIN)		1
AV In (3 RCA)		1
AV Out (3 RCA)		1 (ONLY L, R)
D-Sub 15		1
Headphone		1
CVBS In		3
Y\C In		1
RGB+FB -Video		1
RGB+HS, VS In -Graphics		1
CVBS Out		2

BLOCK DIAGRAM OF MAIN CHASSIS (L5A)

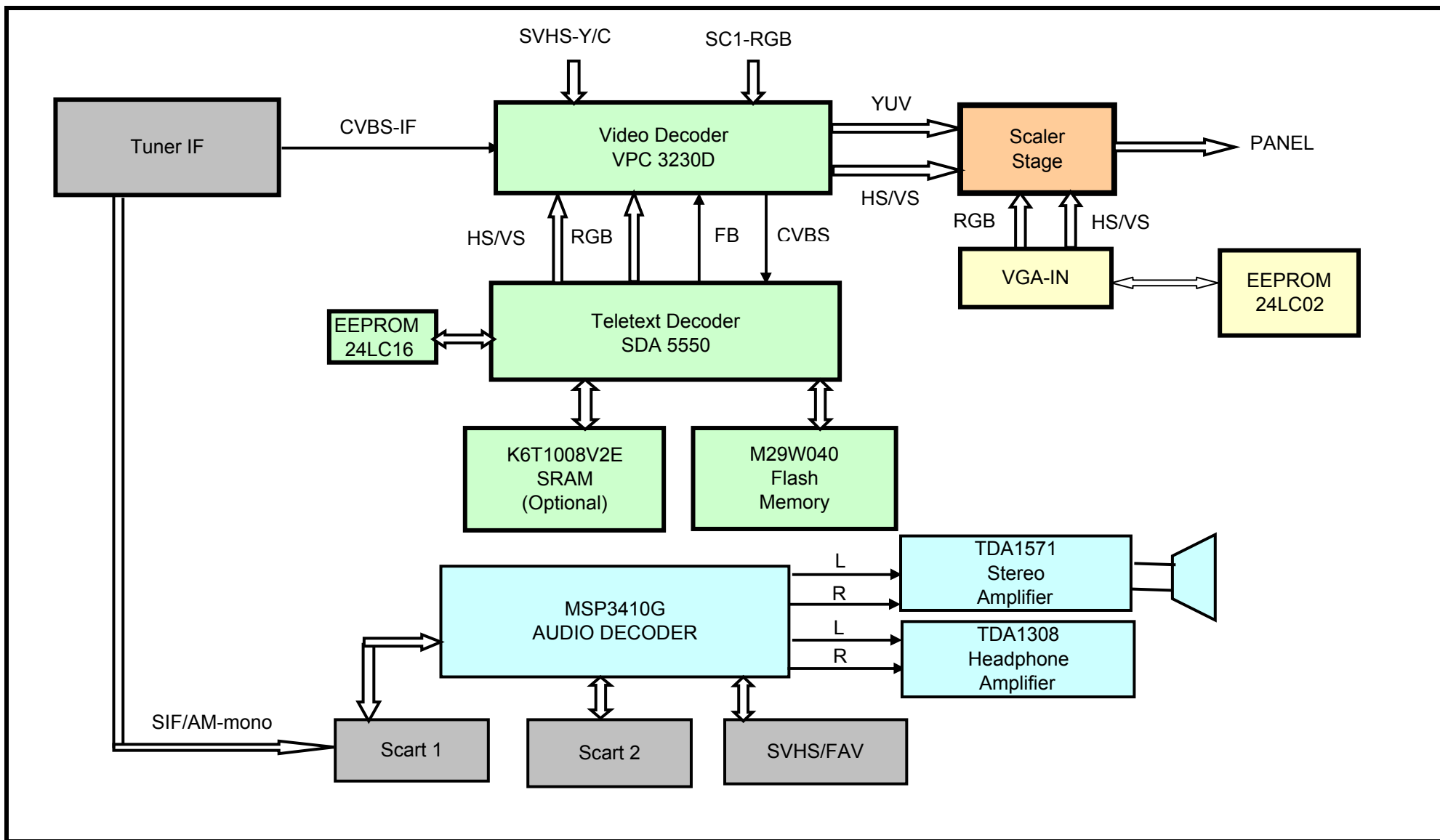

BLOCK DIAGRAM OF SCALER

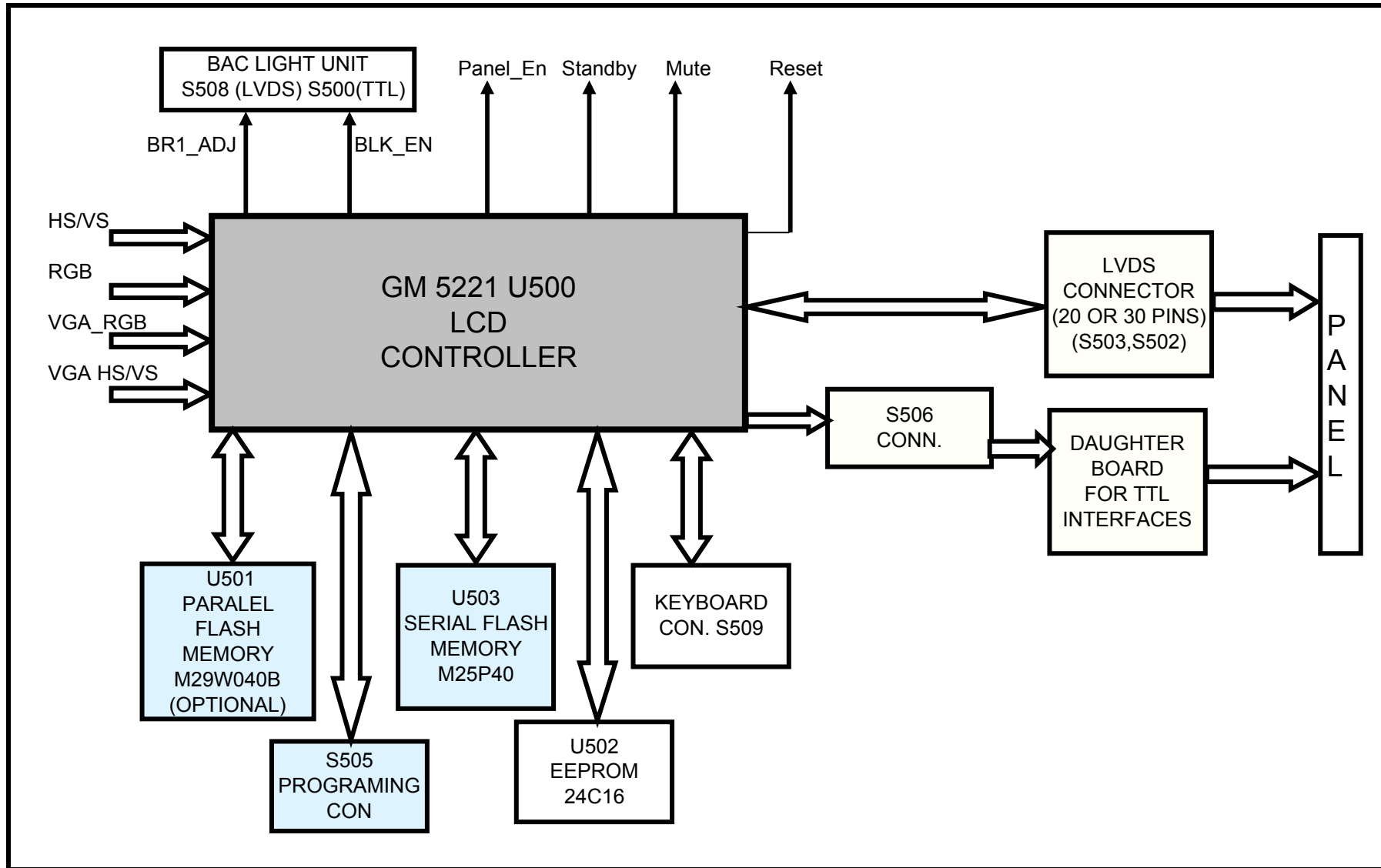

L5A POWER SUPPLY BLOCK DIAGRAM

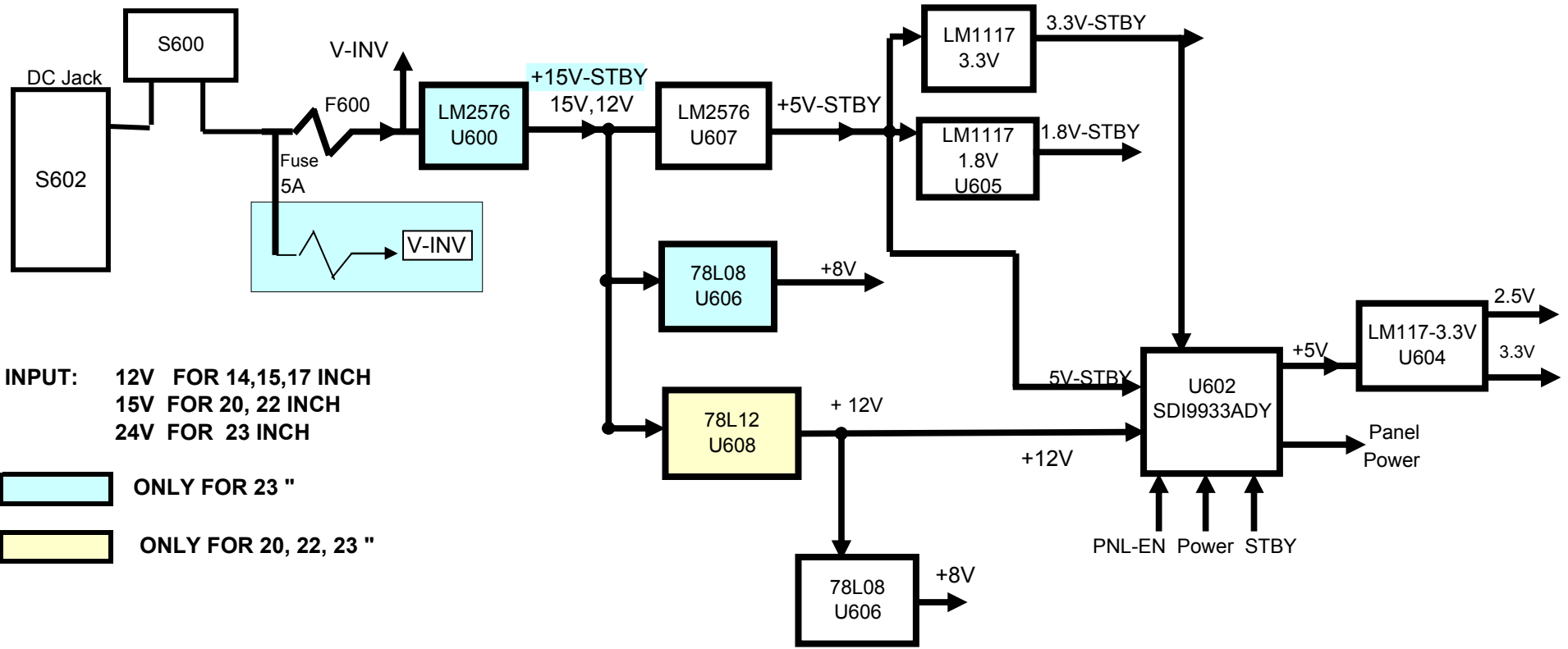

INPUT: 12V FOR 14,15,17 INCH
 15V FOR 20, 22 INCH
 24V FOR 23 INCH

ONLY FOR 23 "
ONLY FOR 20, 22, 23 "

L5-A Low-to-Mid End LCD-TV BOARD OVERVIEW

L5-A Low-to-Mid End LCD TV board incorporates the LCD Controller gm2221, to create a high quality, stand-alone LCD-based TV system for consumer applications. Figure 1 illustrates the Block diagram of the board.

This board supposed to have two versions:

1. Low-End (to drive 14"-15" 4:3 panels)
2. Mid-End (to drive 17"-20" 4:3 and 17"-22"-23" 16:9 panels)

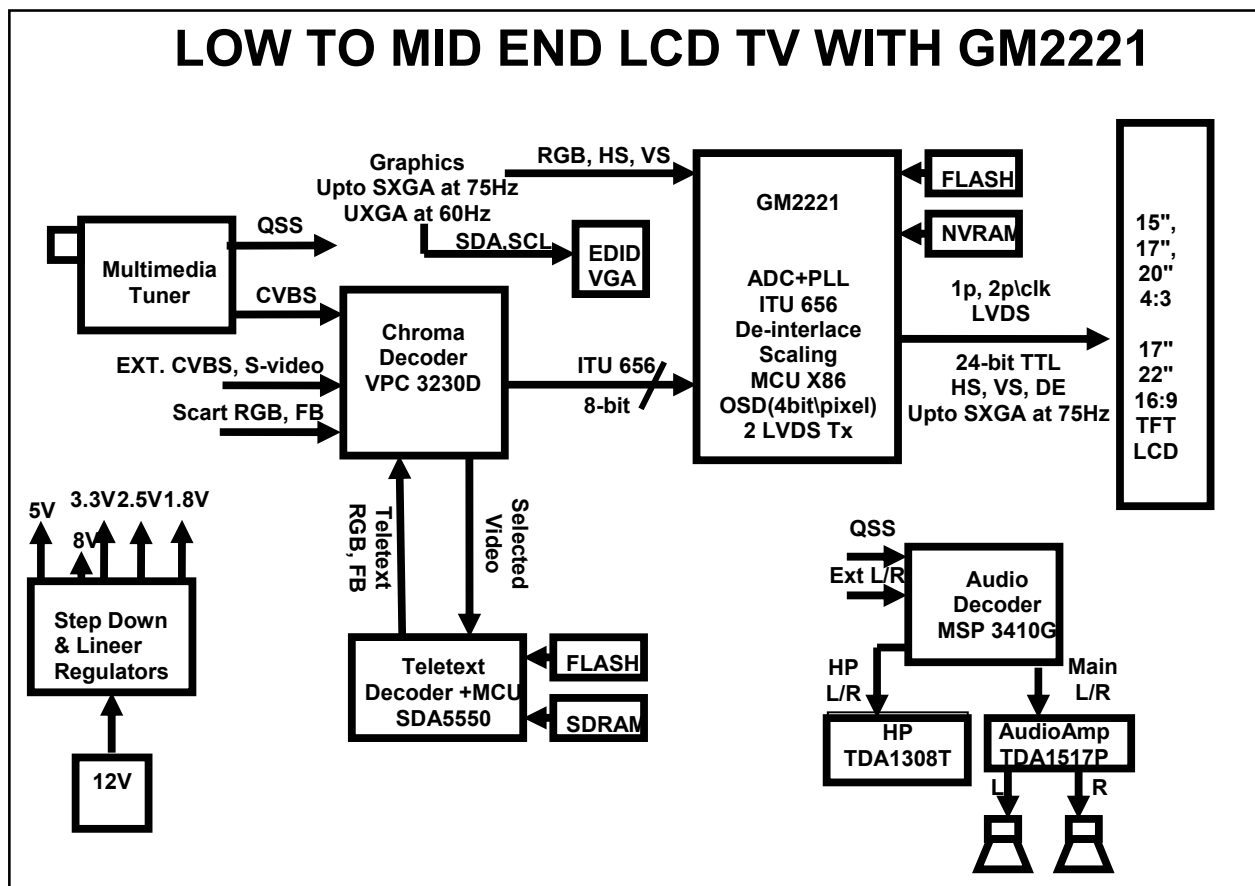

Figure 1 System Block Diagram

L5-A board supports 5 types of video and graphics inputs. These inputs are: Analog terrestrial tuner input for multisystem PAL/SECAM transmission, SCART input (x2), S-VHS input, RCA input and analog PC video input.

The analog RGB signals coming from the PC input (via D-Sub15 connector P401) are directly connected to the gm2221 analog input port.

One EDID IC (U400) is provided on board to support VESA standard plug-and play compatibility.

On the board, one high quality video decoder (U100) is provided (VPC3230D of Micronas) to process video inputs coming from the video sources. The video processor can process 3 composite video inputs and 1 S-Cideo input from the NTSC/PAL video sources. The CVBS output recovered from the tuner module is made available to one of the video inputs of the video decoder.

The digitized video output (in ITU-656 format) from U100 is fed to the dedicated video Port of gm2221 for decoding and processing.

Gm2221 makes it possible to perform scaling and de-interlacing for the video input.

A 4Mbit serial flash ROM (U503) is used for storing system firmware. Also the footprint for a parallel flash ROM, which can be upto 2Mbits, is available on the board. This option can be used either for development or for production purposes.

The gm2221 provides direct connect via the integrated LVDS transmitters to LCD panels with integrated LVDS receivers. Both single LVDS (via S503) and double LVDS(via S502) panels can be supported directly from the L5-A main-board. For single LVDS panels, only S503 connector is soldered on the main-board, which is a 20 pin connector. For Double LVDS panels, only S502 connector is soldered on the main-board, which is a 30 pin connector. For supporting different LVDS panels, different LVDS cables (either single or double LVDS) can be made used.

For supporting different single or double TTL panels, a daughter board interface is used via 40 pin S506 connector. On this connector, the signals are 3x8bit RGB with TTL control signals (i.e. HSync, VSync, CLK, O/E etc.) to support a wide variety of LCD panels. Depending on the panel used, different daughter boards will be used to support that particular panel. For single TTL panels, the daughter board will just be a routing the RGB and control signals to the particular connector interface for that particular panel. For double TTL panels, there will be two LVDS receiver IC's on the daughter board (double TTL is not directly from GM2221 but double LVDS is supporter due to IC packaging problems) to demodulate double LVDS signal into double TTL signal.

The LCD panel resolution supported can be up to SXGA at 75 Hz or UXGA at 60 Hz.

It is important to note that at any point in time gm2221 could drive only one type of Panel. When LVDS Panel is connected (to connector S503 or S502) ensure that the panel backlight is connected to S508. The integrated PWM output from gm2221 is used to control the LCD panel backlight intensity for dimming functions.

The on screen display is implemented using OSD capability of gm2221. Infra Remote (IR) controller connector (S507) is provided as a primary control interface for connecting IR detector to the GPIO of gm2221. An IR remote controller unit and detector provide remote OSD menu access at user convenience.

A keypad connector (S507) is provided which utilizes the integrated low bandwidth ADC in gm2221 for scanning 5-6 keys (menu,V+,V-,P+,P- keys standard- source key optional) on the keypad. The keypad allows access to the OSD without using the remote IR controller.

The L5-A board also has In System Programming (ISP) capability for the external flash ROM using DDC2Bi. This can be done using the D-Sub 15 (PC) connector on the board. ISP can also be performed using G-probe through the RS232 interface.

One channel of the dual channel FET power switch (U602) is used to control the power sequencing to the LCD panel. Depending on the type of the panel, the input voltage to this FET device can be chosen as shown below:

For +3.3V panels J601 is soldered on the main-board
For +5V panels J600 is soldered on the main-board
For +12V panels J603 is soldered on the main-board

An LM2576, a step-down regulator IC (U600), is used to generate the main +5V_STBY voltage on the board. This IC can deliver up-to 3 Amperes of 5Volts. There is no stand-by control for this regulator, which means this IC is always on, as soon as power is supplied to the board.

U603(+3.3V_STBY) and U605 (+1.8V_STBY) linear regulators are used to supply the voltage necessary for the GM2221 IC and some peripherals. These voltages are also available in stand-by mode to power the microprocessor inside gm2221, LED, IR receiver IC and EEPROM. These devices are necessary to wake up the board from stand-by state.

Second channel of the dual channel FET power switch (U602) is used to control cut some voltages in stand-by mode. These voltages are +5V, +3.3V and +2.5V. These voltages are used by the video processor (VPC 3230D), audio processor (MSP 34x0G), teletext processor (SDA5550), tuner and some peripheral IC's and circuitry. In order to limit the stand-by power consumption, these voltages are not available in stand-by mode. Also the audio amplifier (TDA1517) is also in its stand-by mode using its dedicated stand-by pin.

The board employs MSP3410G, a multi-system audio processor solution from Micronas. The system supports 4 audio input ports, one of which is not used on the L5-A board. Audio output is provided with speaker and headphone jacks (S409, S401) provided on the board. The sound IF signal from the tuner is connected to the audio processor directly.

4. GM2221 LCD TV CONTROLLER

The gm2221 IC is a highly integrated single channel scaler that can be used for both LCD monitors up to SXGA/UXGA resolutions and rear projection systems with DLP and HTPS LCD engines up to 1280x720 (720P). Some of the key features include:

- Single processing channel.
- RGB and YUV signal processing with RGB to YUV and YUV to RGB color space converters.
- Video signal processing/de-interlacing using spatial, VT (vertical-temporal) diagonal interpolation.
- The on-chip turbo x86 micro-controller is used as the system CPU.
- The on-chip OSD controller is available for creating bitmapped OSD menus
- The keypad buttons utilize the input of the on-chip low bandwidth ADC.
- Software IR decoders is used with an external remote controller.
- One of the on-chip PWM outputs is used for controlling back-light intensity
- Integrated LVDS transmitters to LCD panels with integrated LVDS receivers.

The LCD panel resolution supported can be up to SXGA resolutions.

6. LCD PANEL INTERFACE

The L5-A board can drive panels both with LVDS and TTL interfaces. The footprints for single LVDS and double LVDS connectors are available on the board (S503 and S502, respectively). Either of these connectors can be used without any changes on the board. The TTL interface is supported by a daughter board (S506 is the connector for the daughter board). For the TTL case, connecting the daughter board to the connector will be sufficient.

A Hirose 30-pin connector (S502) is used for double LVDS link from the board to various LVDS panels. This connector can also be used for single LVDS, but another connector footprint (S503) is available for single LVDS purposes. Using only S503 for single LVDS panels decreases the cost. The LVDS traces are routed differentially from the gm2221 IC to the connector. These are 100-Ohm differential traces.

L5A SERVICE MENU

Service Menu is entered by pressing 9, 3, 0, 1 keys on the remote controller when the Picture icon is highlighted in the Main Menu.

Service Menu has 3 sub-menus. These are:

- Options
- Adjustments
- Selections.

Navigation through these menus can be done by pressing OK button. Every adjustment made in this menu is saved automatically.

OPTIONS

Options are adjustments that the user can select On or Off.

- BG
- DK
- I
- LL'
- SCART 2
- FAV
- SVHS
- HOTEL MODE
- STAND BY
- MSP CARRIER MUTE
- WSS SCART
- FIRST ATS

BG / DK / I / L

Enabling or disabling these options will remove / add these standards to Manual Install menu, SYSTEM item.

SCART 2 / FAV / SVHS

If a source is disabled in the Service Menu, it will be skipped during source switches. If SCART2 is enabled, SW assumes that the FAV source share the same path as the SVHS source on the HW. If it is disabled, it is assumed that FAV and SVHS share separate paths. TUNER and SCART1 are enabled by default.

HOTEL MODE

Enabling Hotel Mode has two effects. First, SETUP menu is no longer accessible by the user. Second, maximum adjustable volume value is limited to HOTEL VOLUME value. This value can be adjusted in the ADJUSTMENTS sub-menu of the Service Menu.

STAND BY

If this Option is OFF, the TV will stay in Stand By mode after a Power On. If this Option is ON, the TV will recall its last stand by status before the Power Off, and switch on from Stand By automatically, if the last state was 'Stand by On'.

MSP CARRIER MUTE

If this option is ON, sound processor's carrier mute functionality will be enabled. The MSP will mute the sound automatically if the signal quality is bad. Setting this option Off will disable this functionality.

WSS RF / WSS SCART

Automatic picture format switching for WSS and Pin8 can be enabled or disabled through this option.

If WSS SCART is set to OFF, AUTO picture format mode will be disabled for SCART1 and SCART2 modes. Pin8 source switching will still be operational, but no picture format changes from Pin8 voltage level will be ignored.

ATS

If this option is set to ON, TV will display Country Selection menu in the next start. After some country is selected, the user will be prompted for the start of AutoProgramming process.

ADJUSTMENTS

This sub-menu contains numeric adjustments. These items are:

- WHITE R
- WHITE G
- WHITE B
- PRESCALE FM
- PRESCALE NICAM
- PRESCALE SCART
- HOTEL VOLUME

WHITE R / WHITE G / WHITE B

These are used for color bias adjustment. Unlike other items in the service menu, changes will take effect immediately.

PRESCALE FM / PRESCALE NICAM / PRESCALE SCART

These are prescale values that will be used for the initialization of the sound processor (MSP), at the next switch on.

HOTEL VOLUME

This value is used as the volume limit, when the Hotel Mode is on.

SELECTIONS

This sub-menu contains selections.

- TUNER TYPE SAMSUNG / PHILIPS
- TELETEXT NO TEXT / FAST / FAST&TOP
- MSP CLIP REDUCE VOL / REDUCE TONE / COMPROMISE / DYNAMIC

TUNER TYPE

One of two supported tuner can be selected from this item. System must be restarted for this change to take effect.

TELETEXT

NO TEXT: Teletext is totally disabled. TXT/MIX button will not be functional. AUTO picture format mode will be disabled in RF, F-AV and SHVS modes. Naming and sorting functionality during Autoprogramming will be disabled.

FAST: TOPtext functionality will be disabled.

FAST&TOP: TOPtext functionality is enabled.

TIMER MODE

If OFF TIMER is selected, the user will be able to enter time of the day info for the TV to switch off. If SLEEP TIMER is selected, the user can specify some time period, after which the TV will go to stand by automatically.

MSP CLIP

This selection identifies which method will be used by the sound processor to prevent clipping effects on volume. Details can be found in data sheet msp34x0g_4pd.pdf, page 30.

AUTOPROGRAMMING

When the user selects the Autoprogram item in Setup menu, Country Selection menu is opened. The user must select a country before the Autoprogramming starts. Broadcast system will be selected according to the country selected.

Broadcast systems according to countries:

BELGIUM	BG + L
CROATIA	BG
CZECH REP.	DK
DENMARK	BG
FINLAND	BG
FRANCE	L + BG
GERMANY	BG
GREECE	BG
HUNGARY	DK
IRELAND	I
ITALY	BG
NETHERLANDS	BG

NORWAY	BG
POLAND	DK
PORTUGAL	BG
SPAIN	BG
SWEDEN	BG
SWITZERLAND	BG + L
TURKEY	BG
UNITED KINGDOM	I

For countries France, Belgium and Switzerland, autoprogramming is done twice. For Belgium and Switzerland, first BG channels will be searched, after the search in BG is done, searching will restart for L standard. If the selected country is France, the sequence of standards is reversed, thus, first L then BG.

TELETEXT LANGUAGES

L5A SW decides which teletext language group will be used for teletext decoding, according to the country selected for autoprogramming. Teletext languages according to countries:

EAST EUROPE: CROATIA ,CZECH_REP, POLAND

WEST EUROPE: BELGIUM ,DENMARK, FINLAND, UK, FRANCE, GERMANY, IRELAND ,ITALY ,NETHERLANDS, NORWAY, PORTUGAL, SPAIN, SWEDEN, SWITZERLAND, HUNGARY

TURKISH-GREEK: GREECE TURKEY

PC MODE

PC mode can be entered by pressing PC button on the remote controller. User can return back to TV mode by pressing the PC or TV buttons.

After the switching to PC mode, VGA input will be displayed on screen, as soon as the mode (input resolution and frequency) is determined.

If there is no input from the VGA input, NO SIGNAL dialog will be displayed for 15 seconds. At the end of this period if there is no signal from VGA input, the TV will go to Sleep State. While in the sleep state, the TV will keep monitoring the VGA input. If VGA signal is detected, the TV will wake from Sleep State, to PC mode. Alternatively, the user may select to switch the TV on from Sleep State, just like switching on from Stand-by. In this case, the set will switch on from TV mode.

<u>ITEM NAME</u>	<u>OPTIONS/ VALUES</u>	<u>DEFAULT VALUES OR SETUP</u>
------------------	----------------------------	--

OPTIONS

BG	ON/OFF	ON
DK	ON/OFF	ON
I	ON/OFF	ON
LL'	ON/OFF	ON
SCART 2	ON/OFF	OFF
FAV	ON/OFF	ON
SVHS	ON/OFF	ON
HOTEL MODE	ON/OFF	OFF
STBY	ON/OFF	OFF
MSP CARRIER MUTE	ON/OFF	OFF
WSS SCART	ON/OFF	ON
FIRST ATS	ON/OFF	OFF
BACKLIGHT POL	ON/OFF	OFF
FACTORY MODE	ON/OFF	OFF

ADJUSTMENTS

WHITE R	0-255	128
WHITE G	0-255	128
WHITE B	0-255	128
PRESCALE FM	0-127	37
PRESCALE NICAM	0-127	63
PRESCALE SCART	0-127	27
HOTEL VOLUME	0-63	16
AGC	0-31	23

SELECTIONS

TUNER TYPE	PHILIPS SAMSUNG	PHILIPS
TELETEXT	FAST&TOP NO TEXT FAST	FAST&TOP
MSP CLIP	REDUCE TONE COMPROMISE DYNAMIC	DYNAMIC

GENESIS GM5221 LCD TV CONTROLLER

The gm5221 is an LCD TV controller supporting resolutions up to SXGA (1280x1024). The gm5221 leverages Genesis patented advanced image-processing technology as well as a proven integrated ADC/PLL and an Ultra-Reliable DVI™ compliant digital receiver to provide excellent image quality. gm5221 also integrates a microcontroller, an OSD controller, advanced color management and dual LVDS transmitters.

1.1 gm5221 System Design Example

Figure 1 below shows a typical dual interface LCD TV system based on the gm5221. Designs based on the gm5221 have reduced system cost, simplified hardware and firmware design and increased reliability because only a minimal number of components are required in the system.

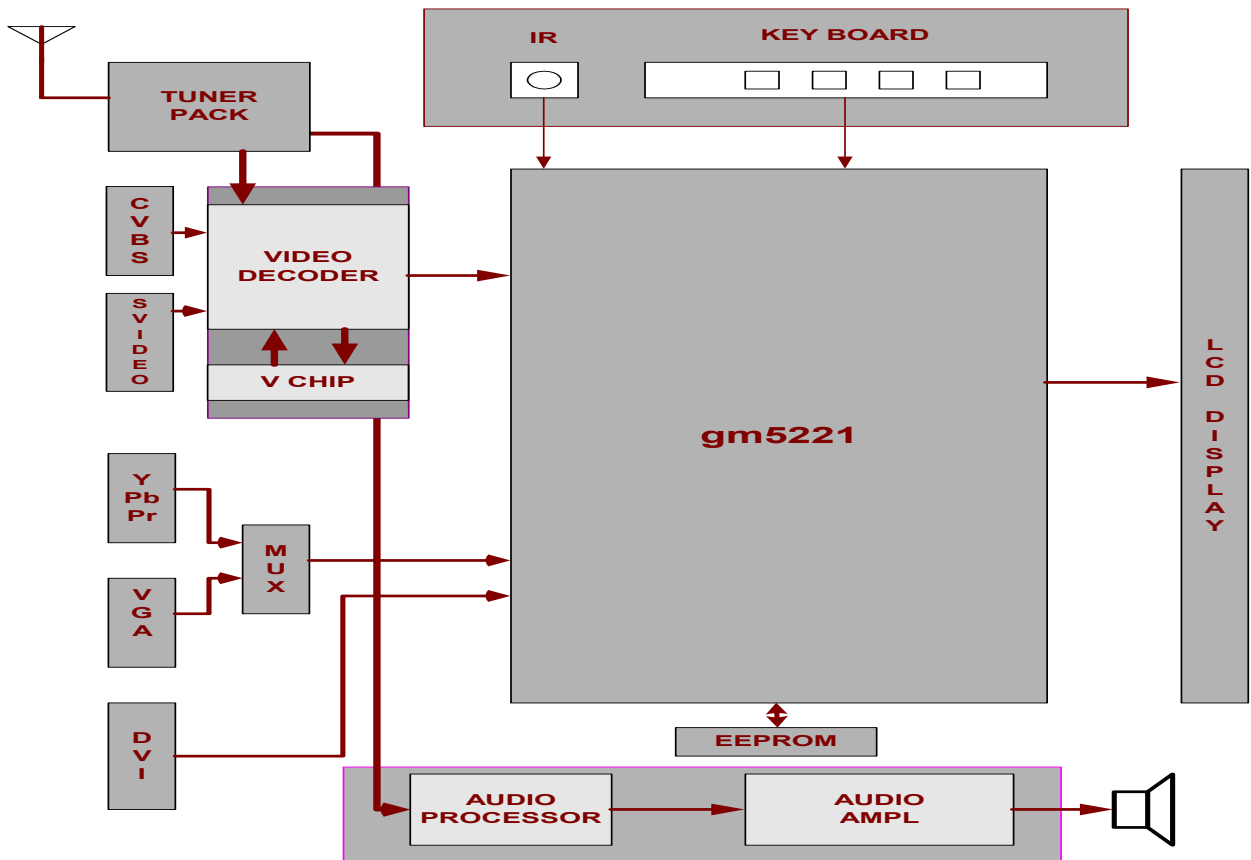

Figure 1. gm5221 System Design Example

1.2 gm5221 Family Features

- **Intelligent Image Processing™**
 - Fully programmable zoom ratios
 - High-quality shrink capability from UXGA resolution
 - Programmable coefficients for variable sharpness control
 - RealRecovery™ provides full color recovery image for refresh rates higher than those supported by the LCD panel
- **Analog RGB Input Port**
 - Supports SDTV RGB inputs in interlaced mode
 - Supports EDTV (480p) up to 1080i HDTV inputs
 - Supports mid level clamp for YPbPr inputs
 - Macro vision decoding
 - Supports up to 162 MHz (SXGA 75Hz / UXGA 60Hz)
 - On-chip high-performance PLLs (single reference crystal required)
 - Composite-sync, Sync-on-Green (SOG) and Sync-on-Y (SoY) support
 - Input format detection
 - Phase and image positioning
- **Ultra-Reliable DVI-Compliant Input Port**
 - Operating up to 165 MHz (up to UXGA 60Hz)
 - Direct connect to all DVI 1.0-compliant transmitters
 - High-bandwidth Digital Content Protection (HDCP)
Note: HDCP function is available H version only.
- **CCIR-656 8-bit Video Input Port**
 - Supporting NTSC / PAL interlaced and progressive
 - Direct connect to commercially available video decoders
 - Spatial de-interlacing
- **Advanced Color Management**
 - Programmable gamma correction (CLUT)
 - TV color controls including hue and saturation controls
 - Full color matrix allows end-users to experience the same colors as viewed on CRTs and other displays (e.g. sRGB compliance)
 - Advanced Active Color Management™ (ACM-II) provide flesh-tone compensation and image enhancement for video preset modes like sport, nature .
 - Adaptive Contrast and Color™ (ACC) ensures full dynamic range is used in video content
- **On-chip Versatile OSD Controller**
 - On-chip RAM for high-quality programmable menus
 - 1, 2 and 4-bit per pixel character cells
 - Horizontal and vertical stretch of OSD menus
 - Blinking, transparency and blending
 - Supports two independent OSD menu rectangles
 - Proportional fonts
- **Embedded X86 On-chip Microcontroller**
 - High-performance X86 MCU with on-chip RAM and ROM
 - External parallel ROM or serial SPI ROM interface
 - Unified memory architecture simplifies chip programming
 - 23 general-purpose inputs/outputs (GPIOs) available
 - 2-wire serial bus master to control NVRAM, video decoder
 - Two DDC2Bi ports with DMA buffer to internal RAM
 - Four PWM outputs for analog backlight control, audio, etc.
 - General-purpose ADC's for keypad and temperature sensing
 - Integrated reset circuit
 - Slow clock mode for 50mW sleep mode power consumption
 - JTAG debug / ICE support for firmware debugging
- **Built-in Test Pattern Generator**
 - Simplifies manufacturing / test
- **Energy Spectrum Management (ESM™)**
 - Digital clock spectrum management
 - Eliminates EMI suppression components and shielding
- **Built-in LVDS Transmitters**
 - Four channel 6/8-bit LVDS transmitter
 - Support for 8 or 6-bit panels with high-quality dithering
 - Single / double wide up to SXGA 75Hz output
 - Pin swap, odd / even swap and red / blue group swap of RGB outputs for flexibility in board layout
- **Highly integrated System-on-a-Chip**
 - All system clocks synthesized from a single external crystal
 - 50mW power saving mode
 - 5-Volt tolerant inputs
 - Two Layer PCB support
 - On-chip reset feature to eliminate external reset component
 - Integrated Schmitt trigger for HSYNC and VSYNC

PACKAGE

- 208-pin PQFP
- 3.3V IO and 1.8V core power supplies

2 gm5221 Pinout

The gm5221 devices are packaged in a 208-pin Plastic Quad Flat Pack (PQFP).

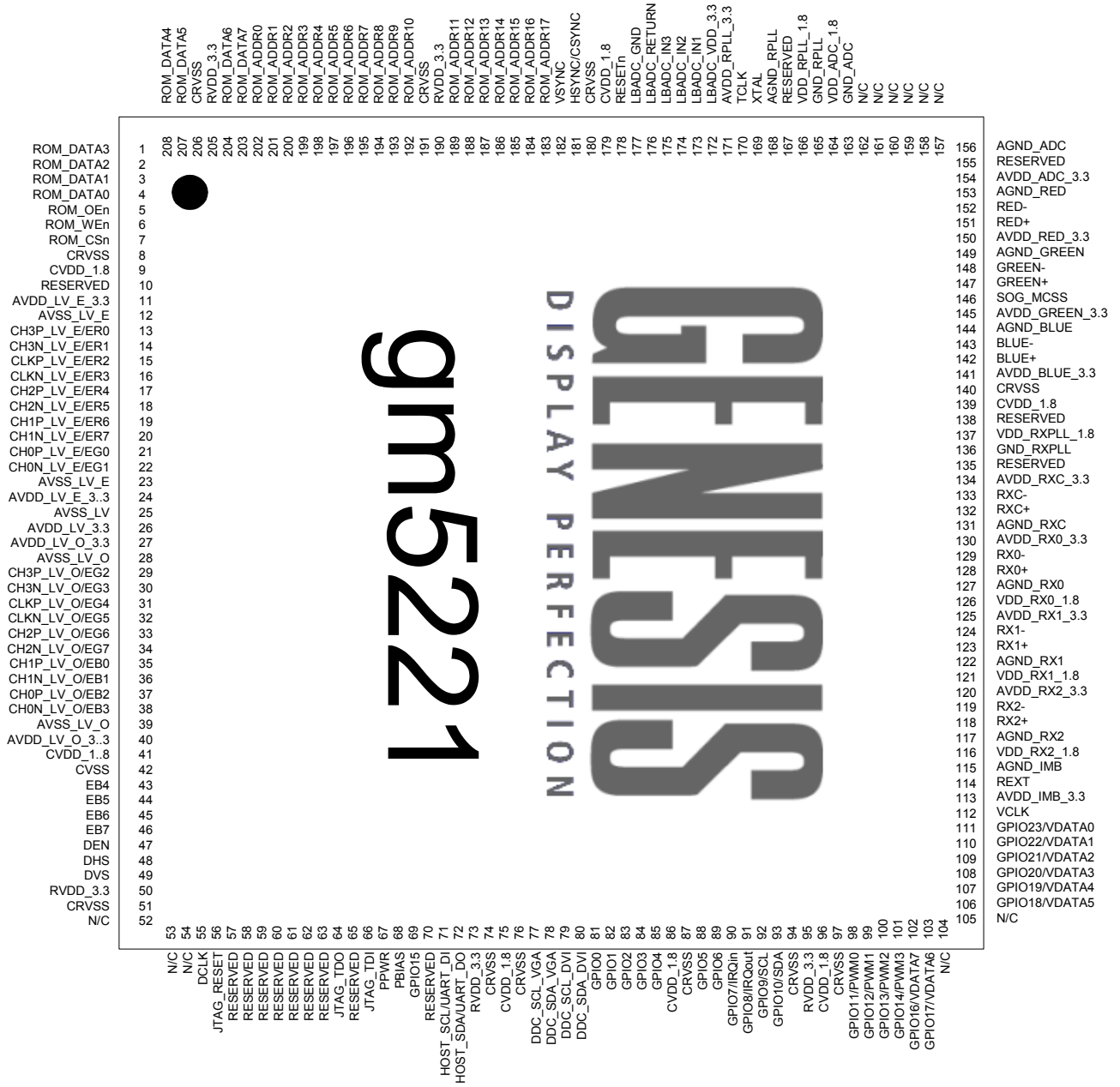
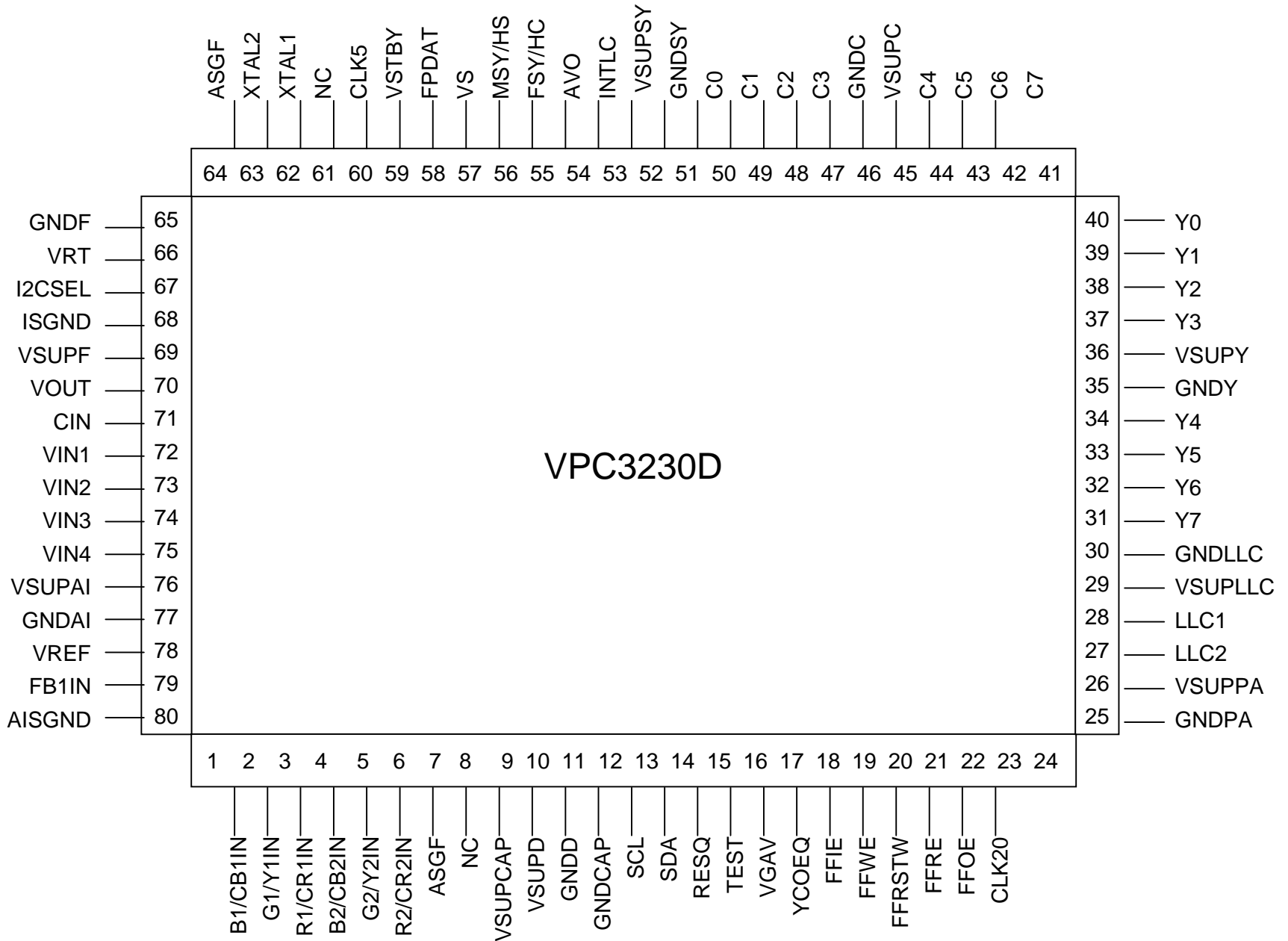

Figure 2. gm5221 Pin Out Diagram

Video Processing - VPC3230D



1. Features

Video Decoding

- 4 Composite inputs, 1 S-VHS input
- Composite video & sync output
- integrated high-quality A/D converters
- Adaptive 2H comb filter Y/C separator
- 1H NTSC comb filter
- Multi-standard color decoder(1 Crystal)
- Multi-standard sync decoder
- Black line detector

Video Decoding

- Horizontal scaling(0.25 to 4)
- Panorama vision
- Black level expander
- Dynamic peaking
- Soft limiter(gamma correction)
- Color transient improvement

RGB Processing

- Programmable RGB matrix
- Digital color bus interface
- Additional analog RGB/Fast blank input
- Half contrast switch
- Picture frame generator

Deflection

- Scan velocity modulation output
- High performance H/V deflection
- Separate ADC for tube measurements
- EHT compensation

Miscellaneous

- One 20.25MHz crystal, few external components
- Embedded RISC controller(80 MIPS)
- I²C Bus interface
- Single 5V power supply
- Submicrom COMS technology
- 64 pin PSDIP package

Block Diagram

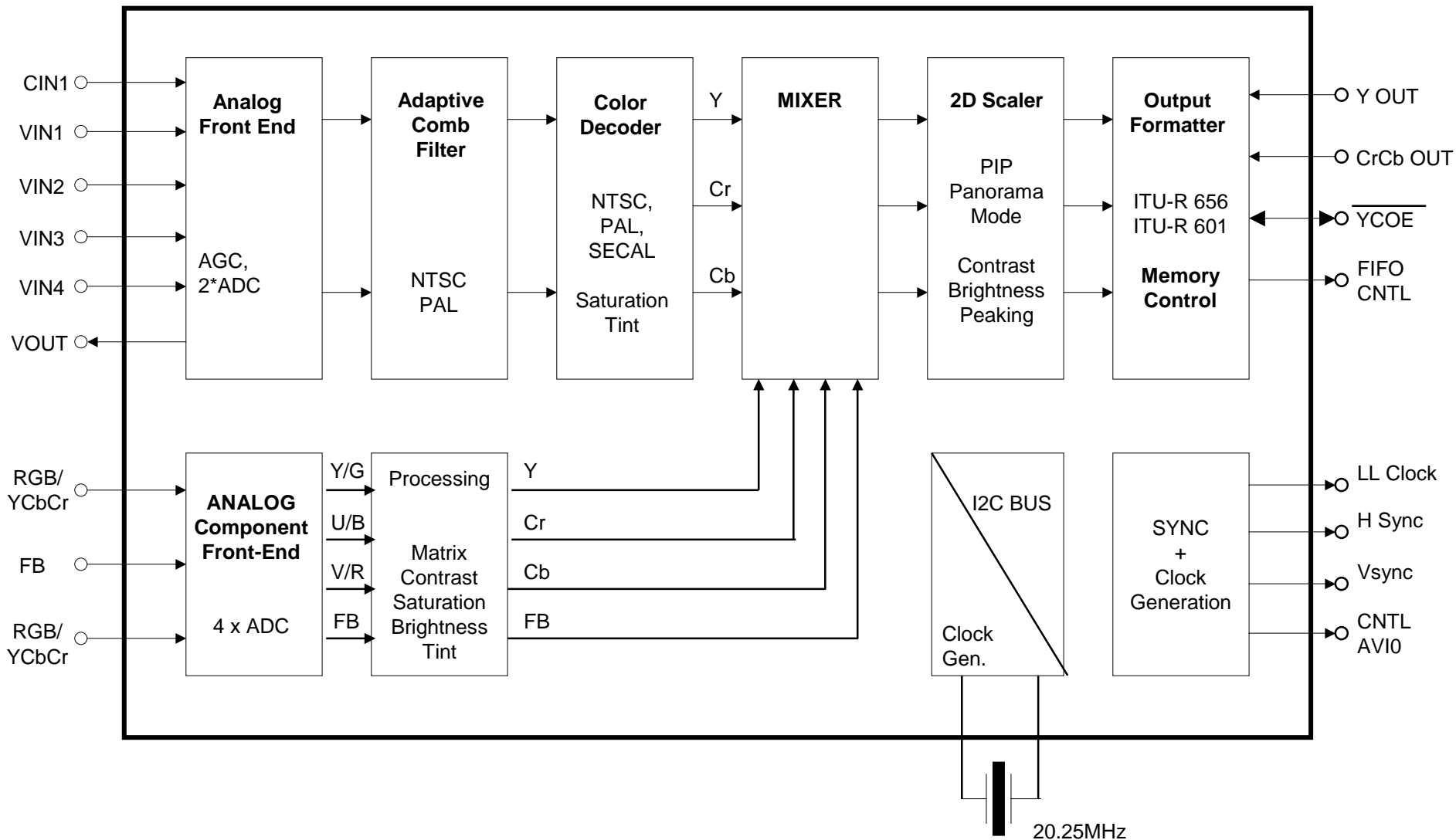

Video Processing - VPC3230D

Pin No.	Pin Name	Type	Short Description
1	B1/CB1IN	IN	Blue1/Cb1 Analog Component Input
2	G1/Y1IN	IN	Green1/Y1 Analog Component Input
3	R1/CR1IN	IN	Red1/Cr1 Analog Component Input
4	B2/CB2IN	IN	Blue2/Cb2 Analog Component Input
5	G2/Y2IN	IN	Green2/Y2 Analog Component Input
6	R2/CR2IN	IN	Red2/Cr2 Analog Component Input
7	ASGF		Analog Shield GND F
8	NC	-	No connected
9	V SUPCAF	SUPPLYD	Supply Voltage, Digital Decoupling Circuitry
10	V SUPD	SUPPLYD	Supply Voltage, Digital Circuitry
11	GND D	SUPPLYD	Ground, Digital Circuitry
12	GND CAP	SUPPLYD	Ground, Digital Decoupling Circuitry
13	SCL	IN/OUT	I 2 C Bus Clock
14	SDA	IN/OUT	I 2 C Bus Data
15	RESQ	IN	Reset Input, Active Low
16	TEST	IN	Test Pin, connect to GND D
17	VGAV	IN	VGAV Input
18	YCOEQ	IN	Y/C Output Enable Input, Active Low
19	FFIE	OUT	FIFO Input Enable
20	FFWE	OUT	FIFO Write Enable
21	FFRSTW	OUT	FIFO Reset Write/Read
22	FFRE	OUT	FIFO Read Enable
23	FFOE	OUT	FIFO Output Enable
24	CLK20	IN/OUT	Main Clock Output 20.25 MHz

Pin No.	Pin Name	Type	Short Description
25	GND PA	SUPPLYD	Ground, Pad Decoupling Circuitry
26	V SUPPA	SUPPLYD	Supply Voltage, Pad Decoupling Circuitry
27	LLC2	OUT	Double Clock Output
28	LLC1	IN/OUT	Clock Output
29	V SUPLLC	SUPPLYD	Supply Voltage, LLC Circuitry
30	GND LLC	SUPPLYD	Ground, LLC Circuitry
31	Y7	OUT	Picture Bus Luma (MSB)
32	Y6	OUT	Picture Bus Luma
33	Y5	OUT	Picture Bus Luma
34	Y4	OUT	Picture Bus Luma
35	GND Y	SUPPLYD	Ground, Luma Output Circuitry
36	V SUPY	SUPPLYD	Supply Voltage, Luma Output Circuitry
37	Y3	OUT	Y Picture Bus Luma
38	Y2	OUT	Y Picture Bus Luma
39	Y1	OUT	Y Picture Bus Luma
40	Y0	OUT	Y Picture Bus Luma(LSB)
41	C7	OUT	Picture Bus Chroma (MSB)
42	C6	OUT	Picture Bus Chroma
43	C5	OUT	Picture Bus Chroma
44	C4	OUT	Picture Bus Chroma
45	V SUPC	SUPPLYD	Supply Voltage, Chroma Output Circuitry
46	GND C	SUPPLYD	Ground, Chroma Output Circuitry
47	C3	OUT	Picture Bus Chroma
48	C2	OUT	Picture Bus Chroma

Video Processing - VPC3230D

Pin No.	Pin Name	Type	Short Description
49	C1	OUT	Picture Bus Chroma
50	C0	OUT	Picture Bus Chroma(LSB)
51	GND SY	SUPPLYD	Ground, Sync Pad Circuitry
52	V SUPSY	SUPPLYD	Supply Voltage, Sync Pad Circuitry
53	INTLC	OUT	Interlace Output
54	AVO	OUT	Active Video Output
55	FSY/HC	OUT	Front Sync/ Horizontal Clamp Pulse
56	MSY/HS	IN/OUT	Main Sync/Horizontal Sync Pulse
57	VS	OUT	Vertical Sync Pulse
58	FPDAT	IN/OUT	Front-End/ Back-End Data
59	V STBY	SUPPLYA	Standby Supply Voltage
60	CLK5	OUT	CCU 5 MHz Clock Output
61	NC	-	No connected
62	XTAL1	IN	Analog Crystal Input
63	XTAL2	OUT	Analog Crystal Output
64	ASGF		Analog Shield GND F
65	GND F	SUPPLYA	Ground, Analog Front-End
66	VRT	OUT	Reference Voltage Top, Analog
67	I2CSEL	IN	I 2 C Bus Address Select
68	ISGND	SUPPLYA	Signal Ground for Analog Input, connect to GND F
69	V SUPF	SUPPLYA	Supply Voltage, Analog Front-End
70	VOUT	OUT	Analog Video Output

Pin No.	Pin Name	Type	Short Description
71	CIN	IN	Chroma / Analog Video 5 Input
72	VIN1	IN	Video 1 Analog Input
73	VIN2	IN	Video 2 Analog Input
74	VIN3	IN	Video 3 Analog Input
75	VIN4	IN	Video 4 Analog Input
76	V SUPAI	SUPPLYA	Supply Voltage, Analog Component Inputs Front-End
77	GND AI	SUPPLYA	Ground, Analog Component Inputs Front-End
78	VREF	OUT	Reference Voltage Top, Analog Component Inputs Front-End
79	FB1IN	IN	Fast Blank Input
80	AISGND	SUPPLYA	Signal Ground for Analog Component Inputs, connect to GND AI

Audio Processing - MSP3440G

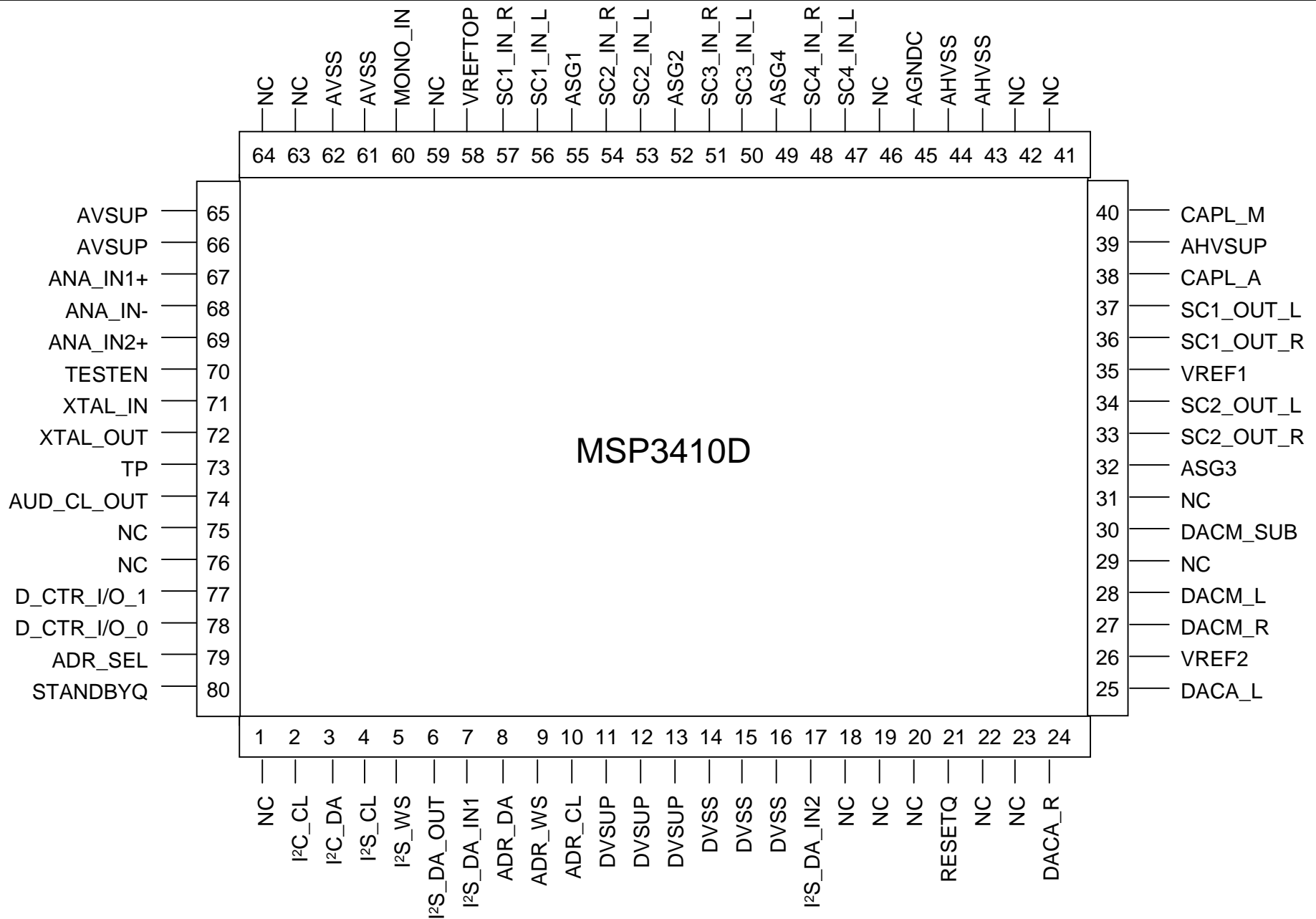

Audio Processing - MSP3410D

Pin No.	Pin Name	Type	Short Description
1	NC		Not connected
2	I2C_CL	IN/OUT	I2Cclock
3	I2C_DA	IN/OUT	I2C data
4	I2S_CL	IN/OUT	I2S clock
5	I2S_WS	IN/OUT	I2S word strobe
6	I2S_DA_O	OUT	I2S data output
7	I2S_DA_IN	IN	I2S1 data input
8	ADR_DA	OUT	ADR data output
9	ADR_WS	OUT	ADR word strobe
10	ADR_CL	SUPPLYD	Supply Voltage, Digital Circuitry
11	DVSUP	SUPPLYD	Ground, Digital Circuitry
12	DVSUP	SUPPLYD	Ground
13	DVSUP	IN/OUT	I 2 C Bus Clock
14	DVSS	IN/OUT	I 2 C Bus Data
15	DVSS	IN	Reset Input, Active Low
16	DVSS	IN	Test Pin, connect to GND D
17	I2S_DA_IN	IN	VGAV Input
18	NC	IN	Y/C Output Enable Input, Active Low
19	NC	OUT	FIFO Input Enable
20	NC	OUT	FIFO Write Enable
21	RESET_Q	OUT	FIFO Reset Write/Read
22	NC	OUT	FIFO Read Enable
23	NC	OUT	FIFO Output Enable
24	DACA_R	IN/OUT	Main Clock Output 20.25 MHz
25	DACA_R	SUPPLYD	Ground

Pin No.	Pin Name	Type	Short Description
26	V SUPPA	SUPPLYD	Supply Voltage
27	LLC2	OUT	Double Clock Output
28	LLC1	IN/OUT	Clock Output
29	V SUPLLC	SUPPLYD	Supply Voltage, LLC Circuitry
30	GND LLC	SUPPLYD	Ground, LLC Circuitry
31	Y7	OUT	Picture Bus Luma (MSB)
32	Y6	OUT	Picture Bus Luma
33	Y5	OUT	Picture Bus Luma
34	Y4	OUT	Picture Bus Luma
35	GND Y	SUPPLYD	Ground, Luma Output Circuitry
36	V SUPY	SUPPLYD	Supply Voltage, Luma Output Circuitry
37	Y3	OUT	Y Picture Bus Luma
38	Y2	OUT	Y Picture Bus Luma
39	Y1	OUT	Y Picture Bus Luma
40	Y0	OUT	Y Picture Bus Luma(LSB)
41	C7	OUT	Picture Bus Chroma (MSB)
42	C6	OUT	Picture Bus Chroma
43	C5	OUT	Picture Bus Chroma
44	C4	OUT	Picture Bus Chroma
45	V SUPC	SUPPLYD	Supply Voltage, Chroma Output Circuitry
46	GND C	SUPPLYD	Ground, Chroma Output Circuitry
47	C3	OUT	Picture Bus Chroma
48	C2	OUT	Picture Bus Chroma
49	C1	OUT	Picture Bus Chroma
50	C0	OUT	Picture Bus Chroma(LSB)

Audio Processing - MSP3440G

Pin No.	Pin Name	Type	Short Description
51	GND SY	SUPPLYD	Ground, Sync Pad Circuitry
52	V SUPSY	SUPPLYD	Supply Voltage, Sync Pad Circuitry
53	INTLC	OUT	Interlace Output
54	AVO	OUT	Active Video Output
55	FSY/HC	OUT	Front Sync/ Horizontal Clamp Pulse
56	MSY/HS	IN/OUT	Main Sync/Horizontal Sync Pulse
57	SC1_in_R	IN	SCART 1input,right
58	VREFTOP		Reference voltage IF A/D converter
59	NC		Not connected
60	MONO_IN	IN	Mono input
61	AVSS		Analog ground
62	AVSS		Analog ground
63	NC		Not connected
64	NC		Not connected
65	AVSUP		Analog power supply 5V
66	AVSUP		Analog power supply 5V
67	ANA_IN+	IN	IF input 1
68	ANA_IN-	IN	IF common{can be left vacant,only if IF input1 is also not in use}
69	ANA_IN2+	IN	IF input{can be left vacant,only if IF input1 is also not in use}
70	TESTEN	IN	Test pin
71	XTAL_IN	IN	Crystal oscillator

Pin No.	Pin Name	Type	Short Description
72	XTAL_OUT	OUT	Crystal oscillator
73	TP		Test pin
74	AUD_CLK	OUT	Audio clock output(18.432MHz)
75	NC		Not connected
76	NC		Not connected
77	D_CTR_I/O	IN/OUT	D_CTR_I/O_1
78	D_CTR_I/O	IN/OUT	D_CTR_I/O_0
79	ADR_SEL	IN	I2C Bus address select
80	STANDBY	IN	Stand-by(low active)

SDA5550 MICROCONTROLLER

Features

General

- Feature selection via special function register
- Simultaneous reception of TTX, VPS, PDC, and WSS (line 23)
- Supply Voltage 2.5 and 3.3 V
- ROM version package P-SDIP 52, P-MQFP64
- Romless version package P-MQFP100,P-LCC84

External Crystal and Programmable clock speed

- Single external 6MHz crystal, all necessary clocks are generated internally
- CPU clock speed selectable via special function registers.
- Normal Mode 33.33 Mhz CPU clock, Power Save mode 8.33 Mhz

Microcontroller Features

- 8bit 8051 instruction set compatible CPU.
- 33.33-MHz internal clock (max.)
- 0.360 μs (min.) instruction cycle
- Two 16-bit timers
- Watchdog timer
- Capture compare timer for infrared remote control decoding
- Pulse width modulation unit (2 channels 14 bit, 6 channels 8 bit)
- ADC (4 channels, 8 bit)
- UART

Pin Configuration P-LCC-84 (ROMless Version) (top view)

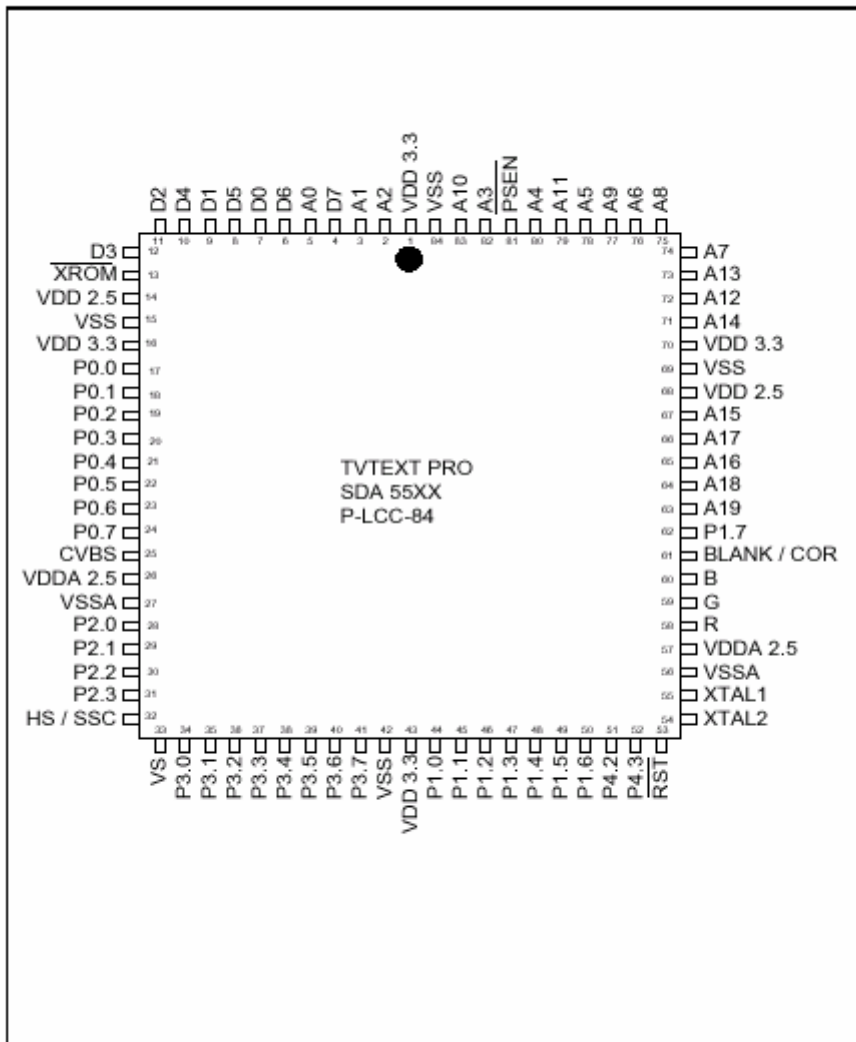

BLOCK DIAGRAM

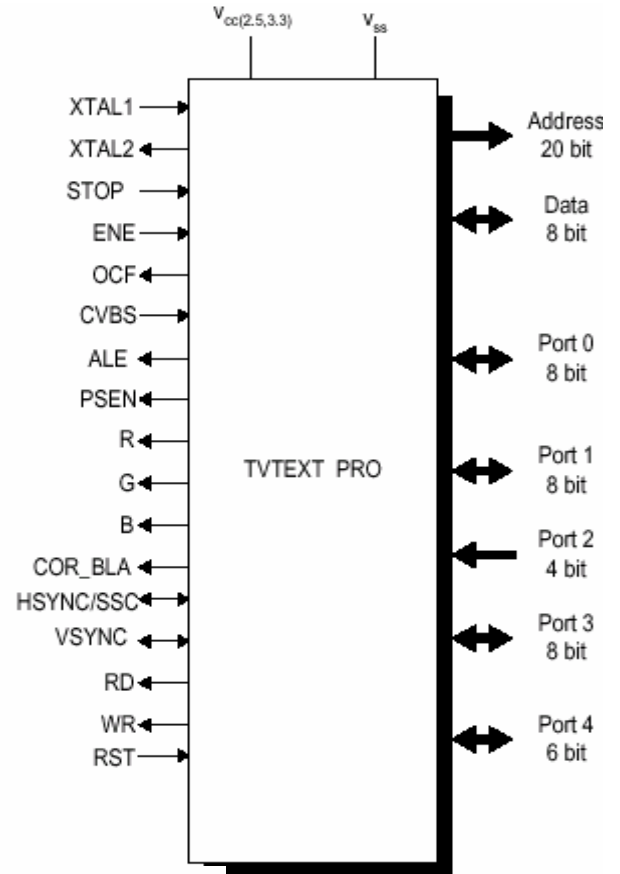

TUNER

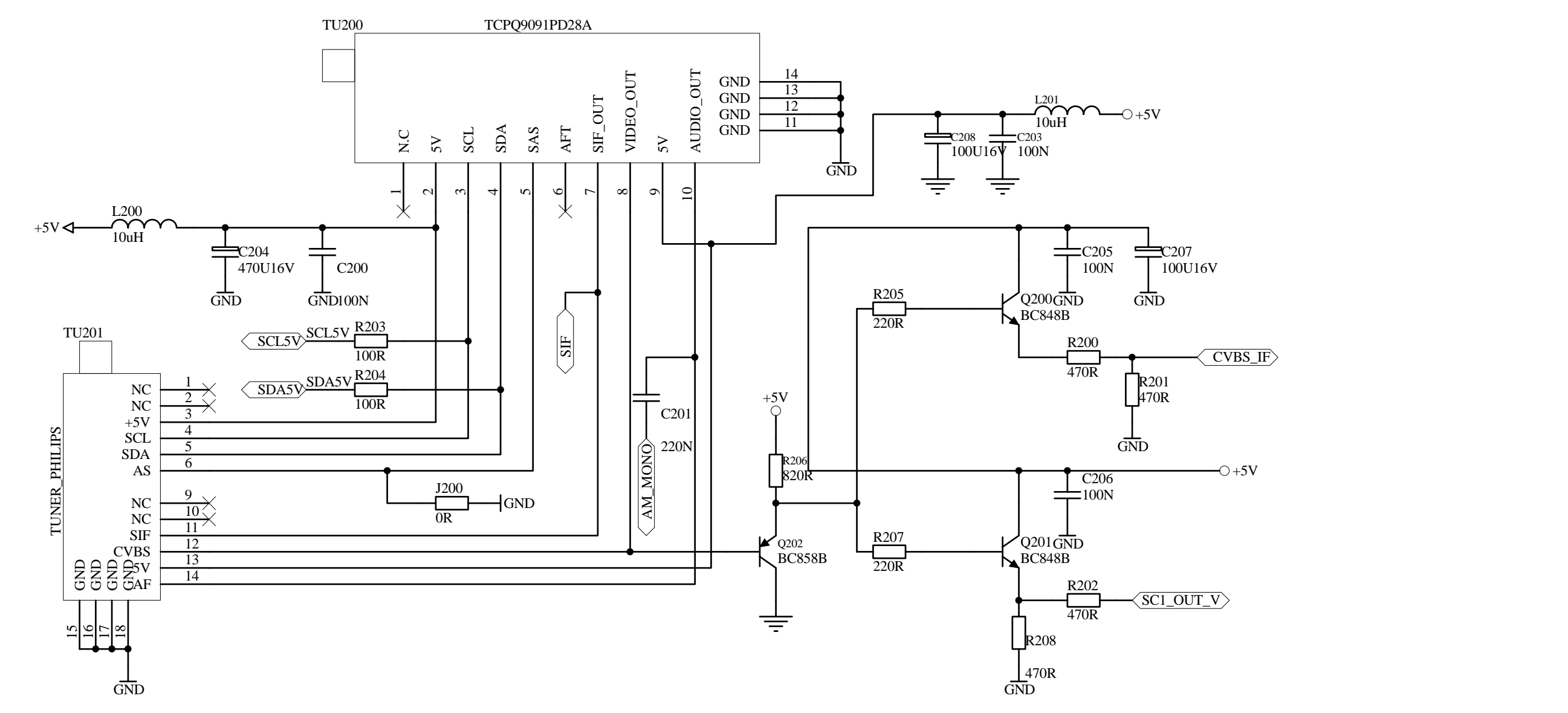

POWER

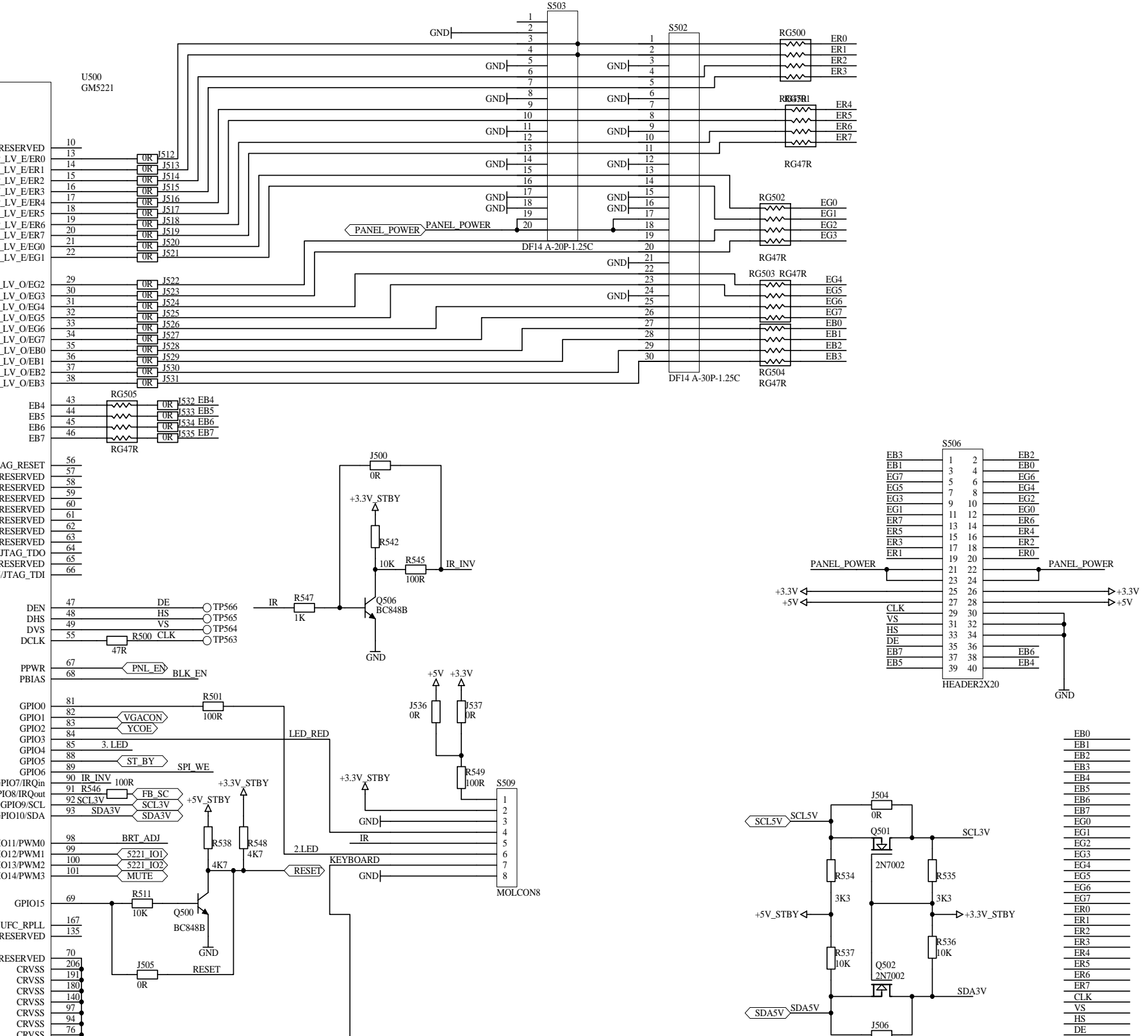
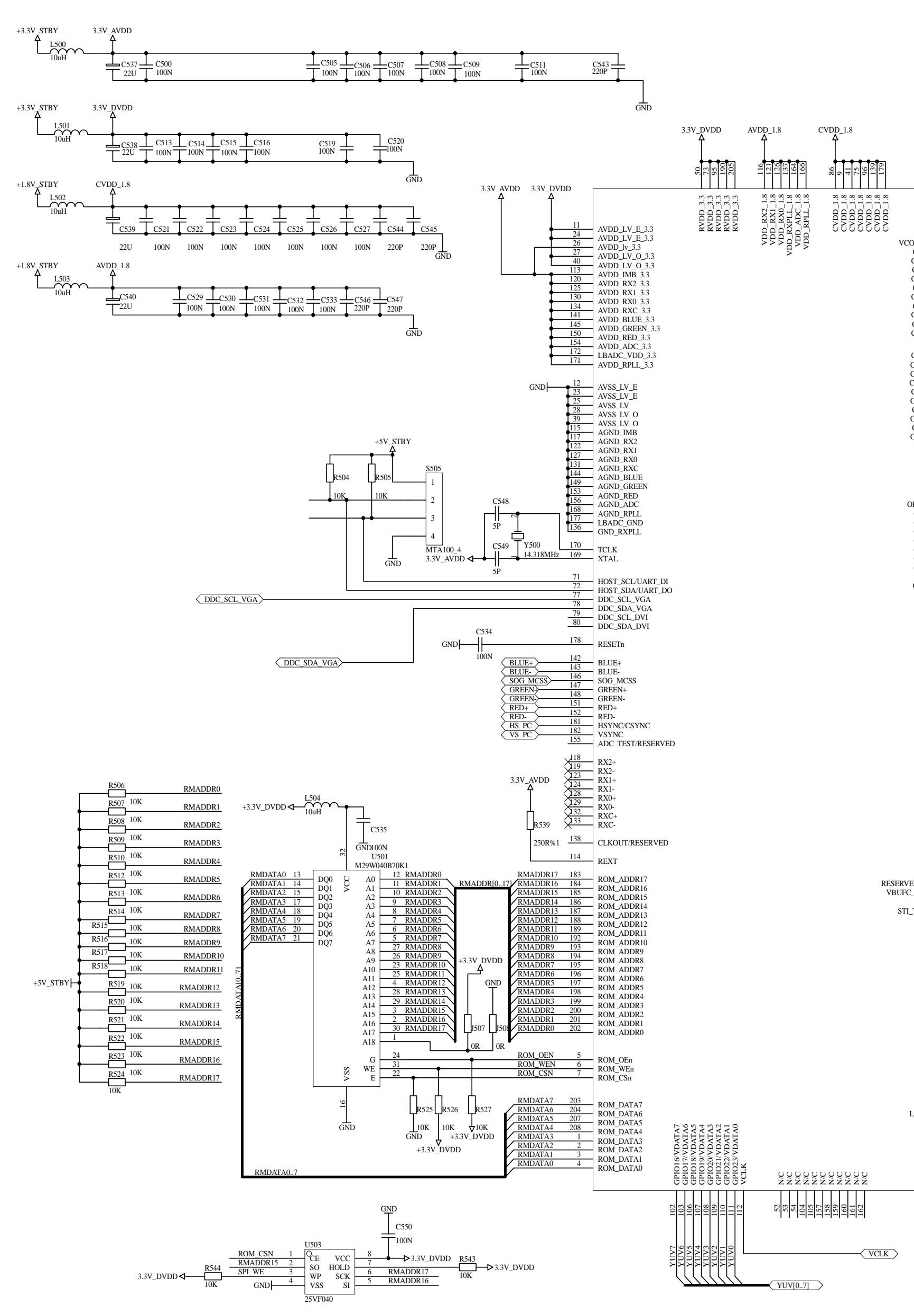
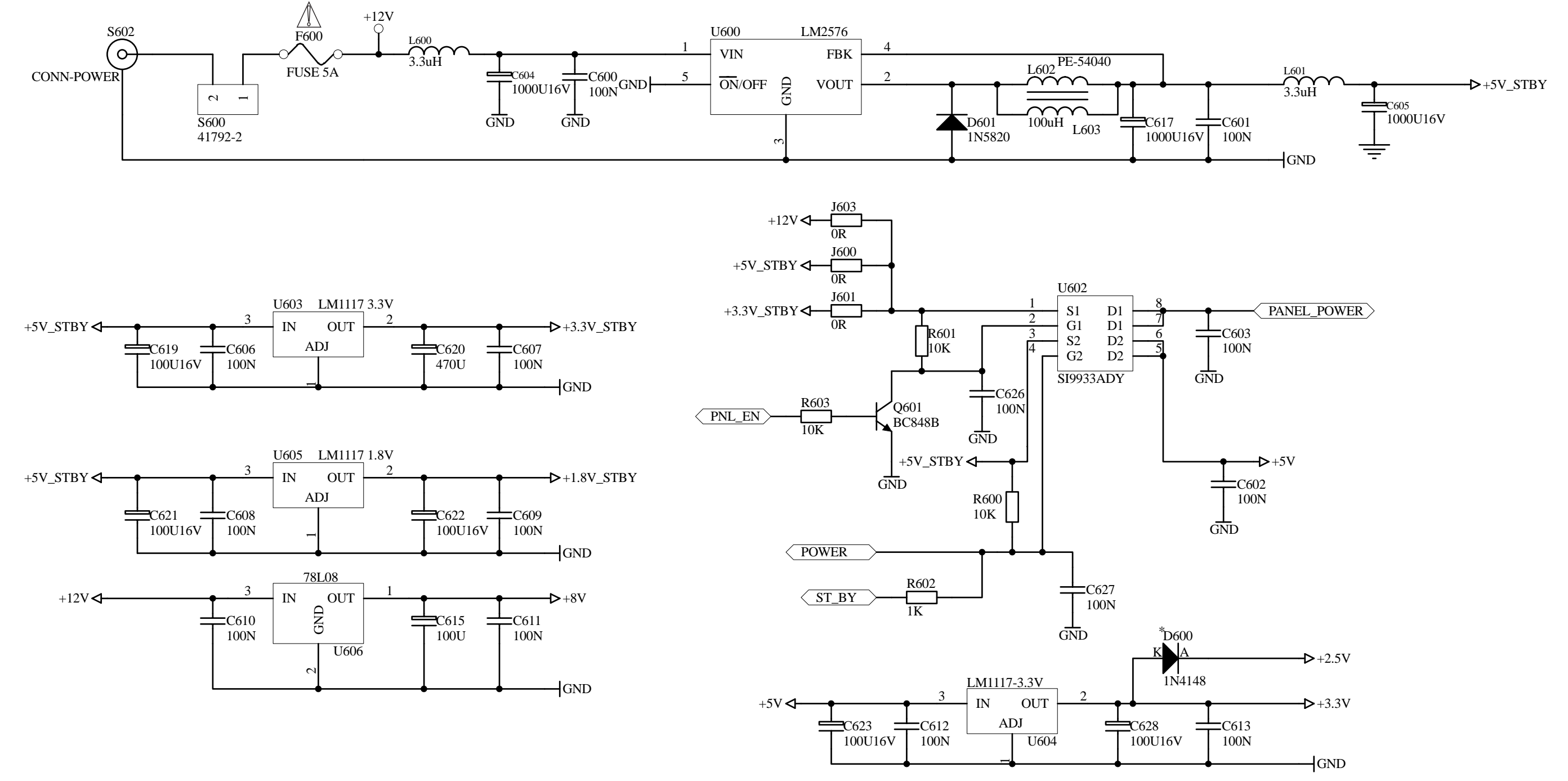

SUBWOOFER

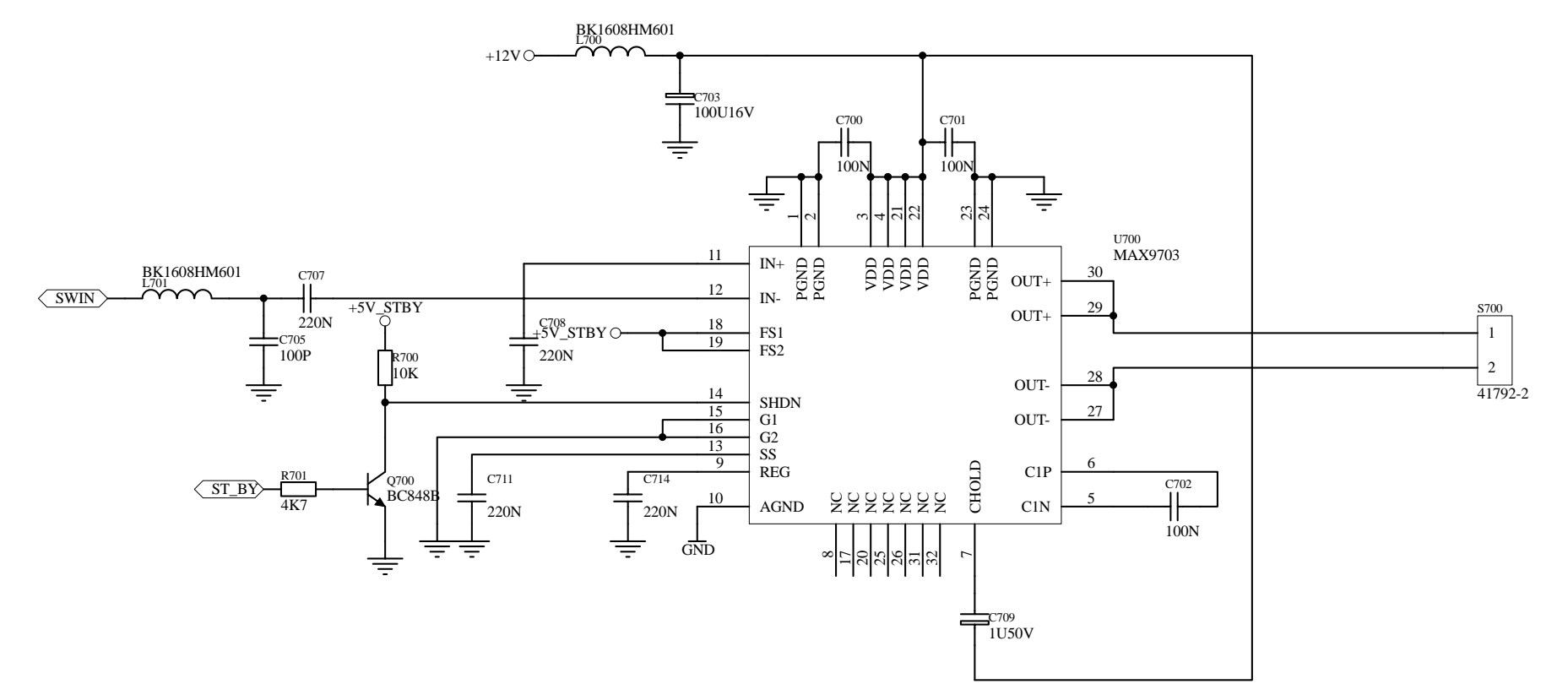

Components designated by the safety symbol should only be replaced by original parts produced and proofed by the manufacturer.
 Sicherheitsbauteile im Sinn der sicherheitsbestimmung. Diese Teile dürfen nur durch Originalteile ersetzt werden.
 Contrassegno di sicurezza. I componenti devono, corrispondere a ricambi originali e devono essere montati a regola d'arte.

VIDEO

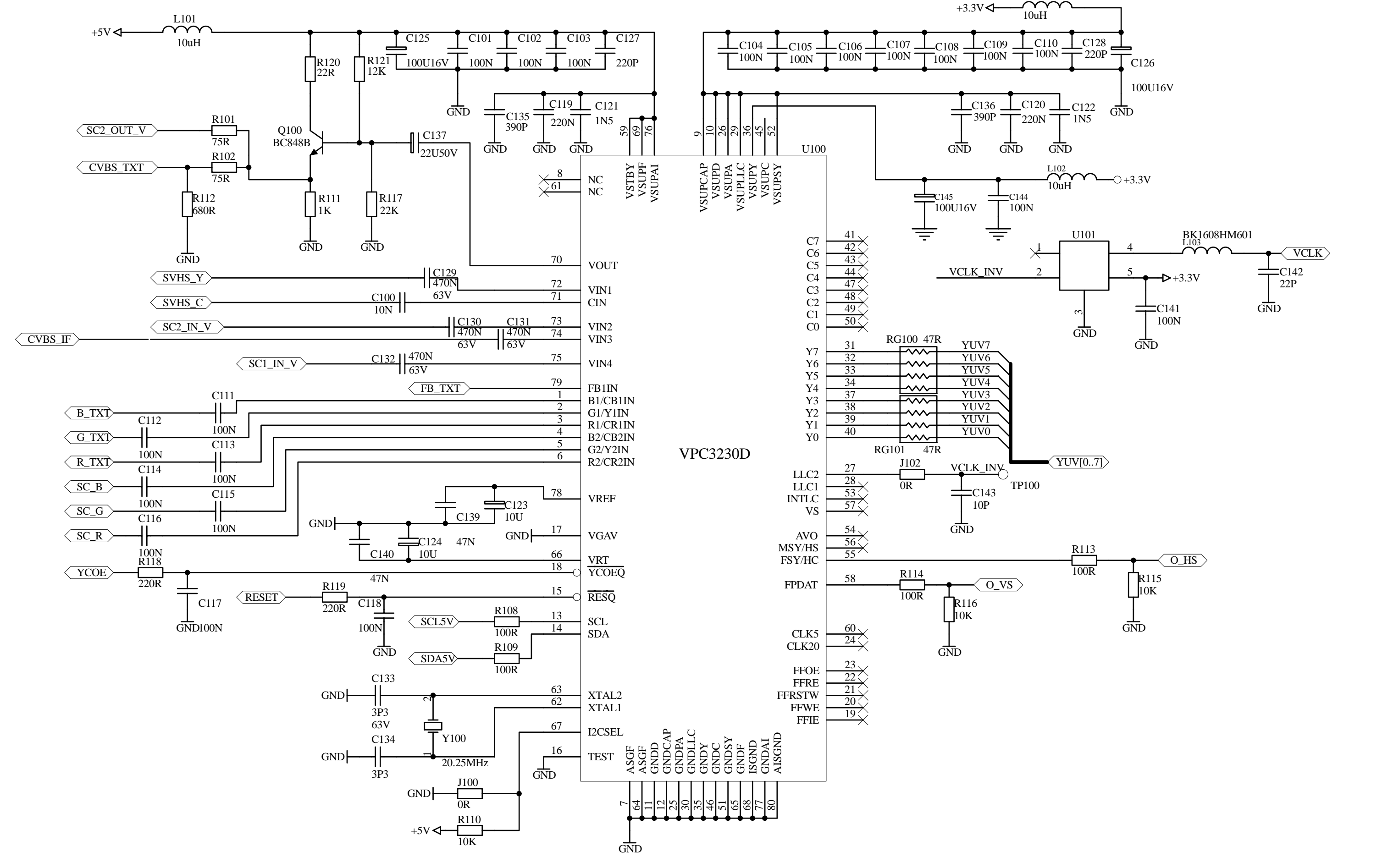

TELETEXT

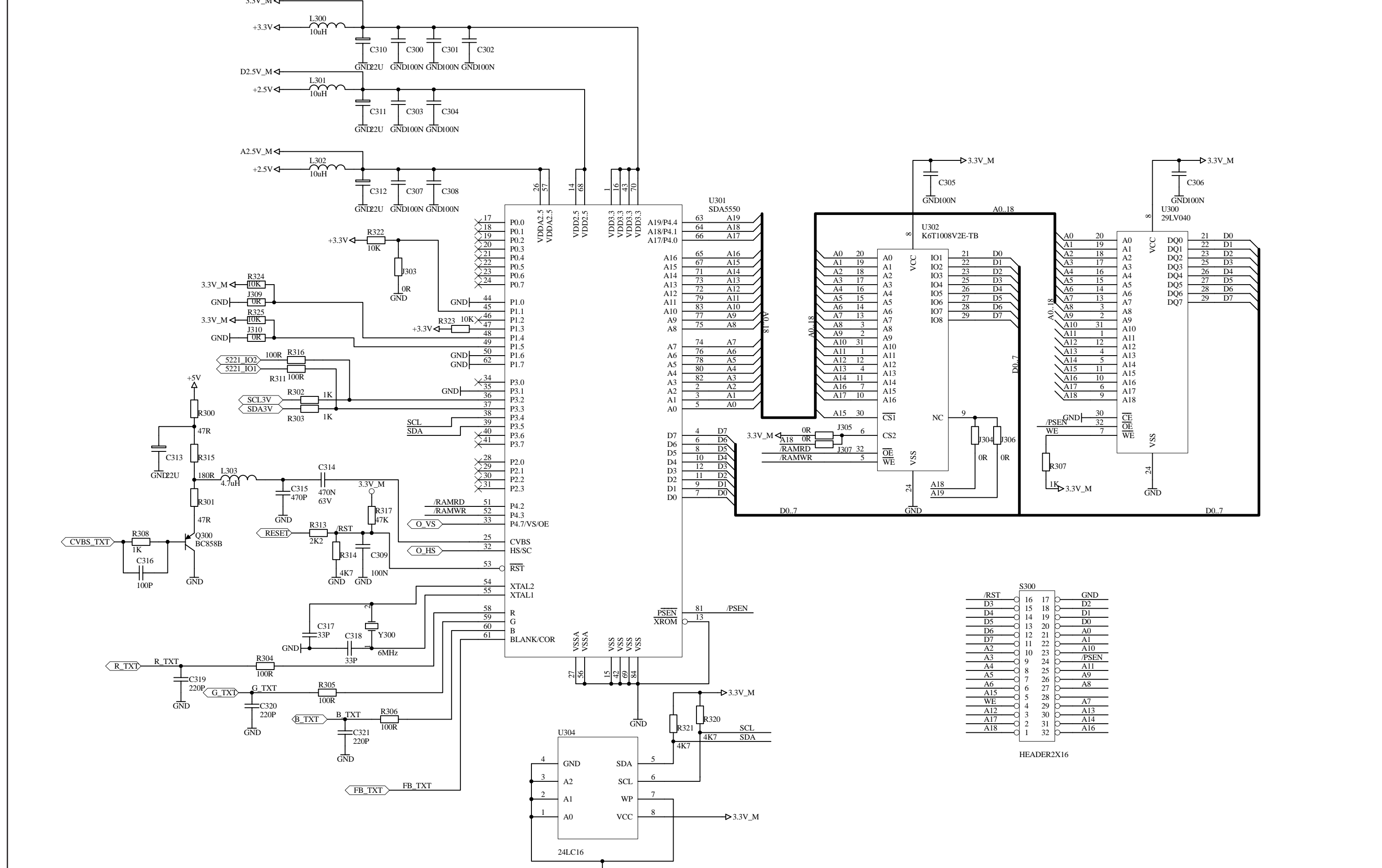

DAUGHTER BOARD

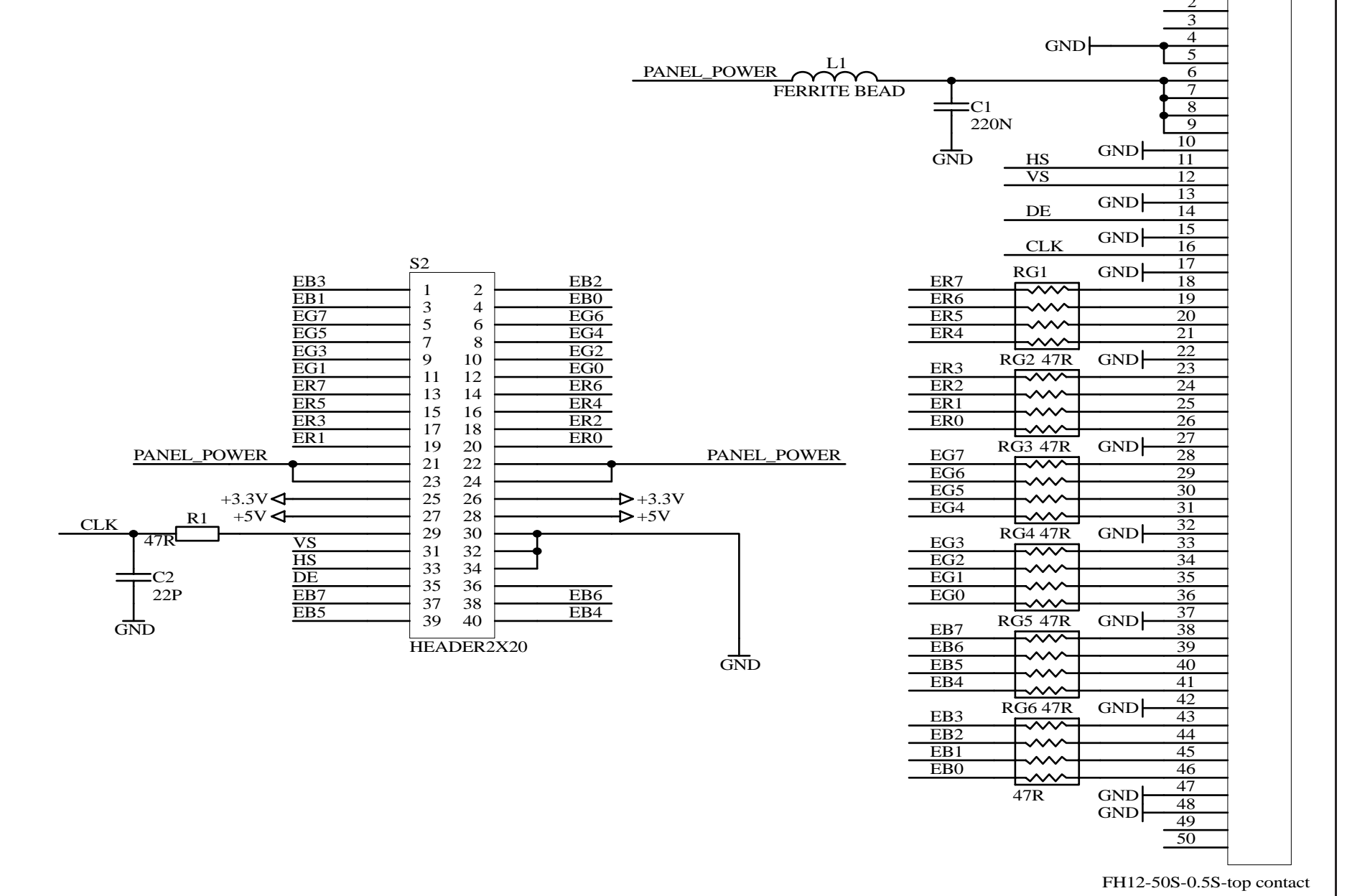

AUDIO

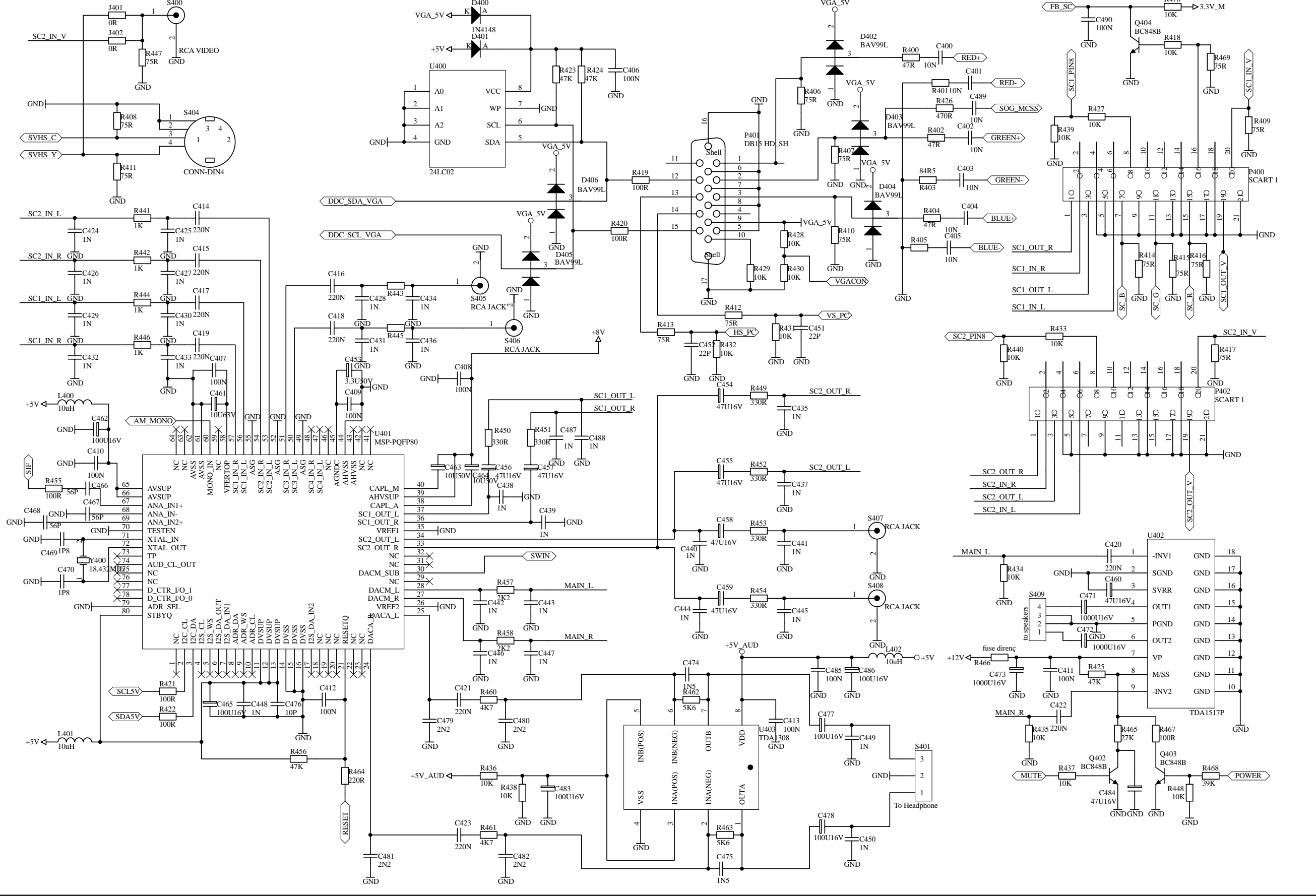

KEYBOARD MODULE

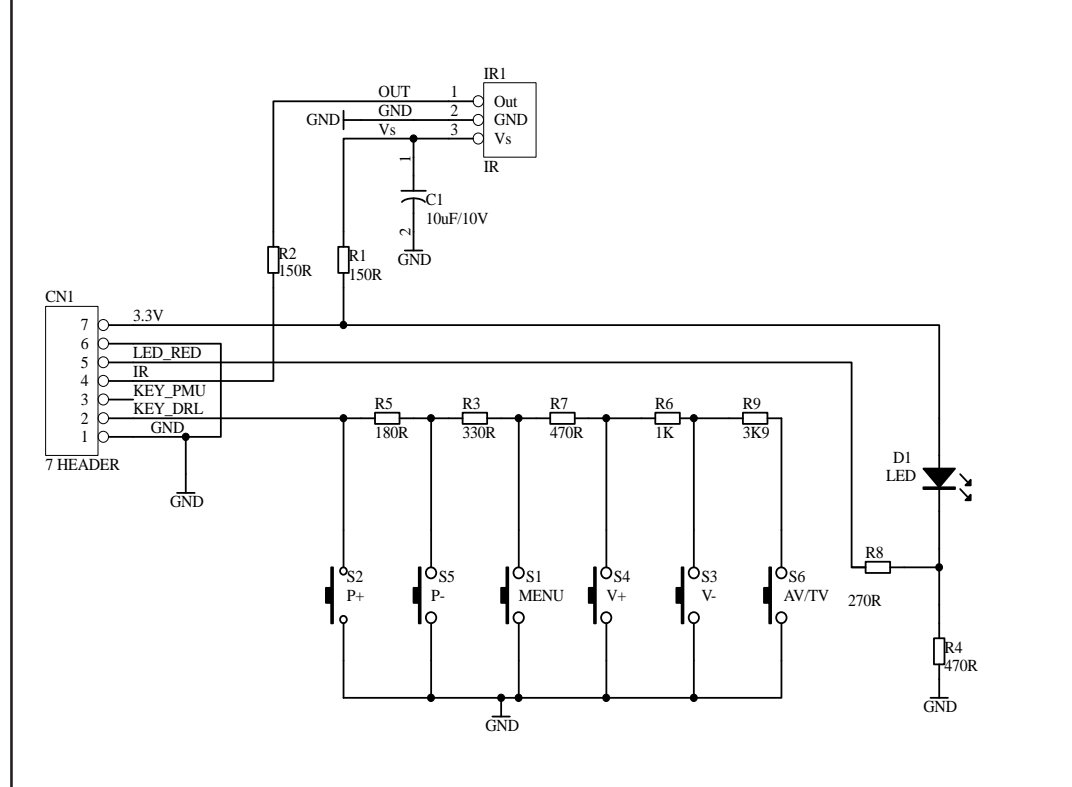

OPTION

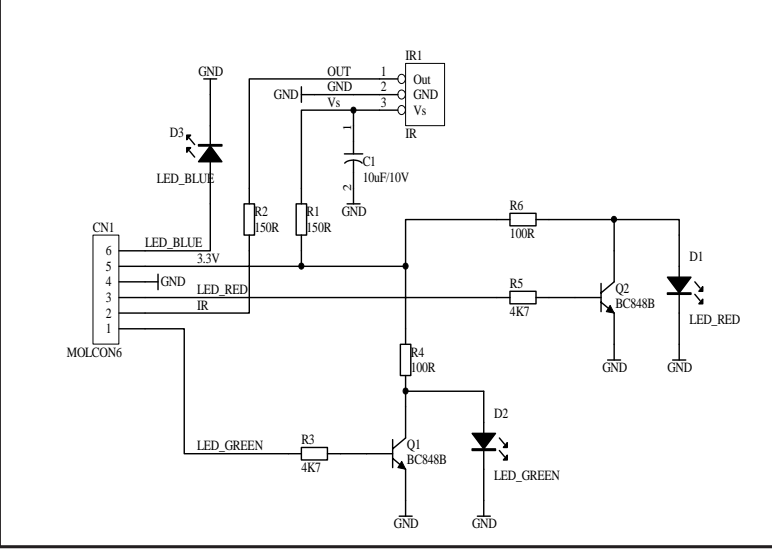

HEAD PHONE MODULE

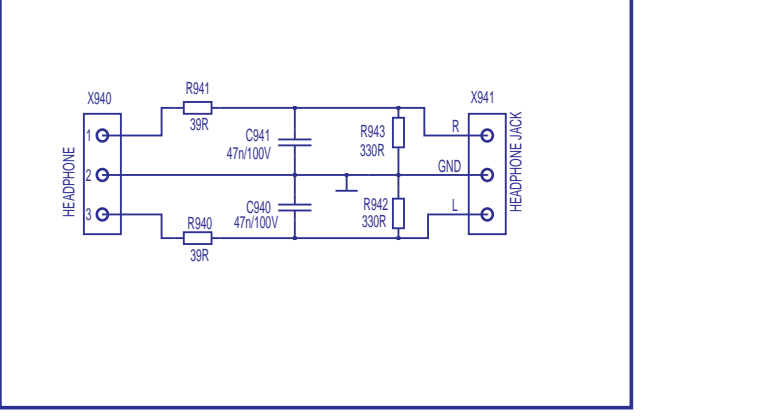

OPTION POWER

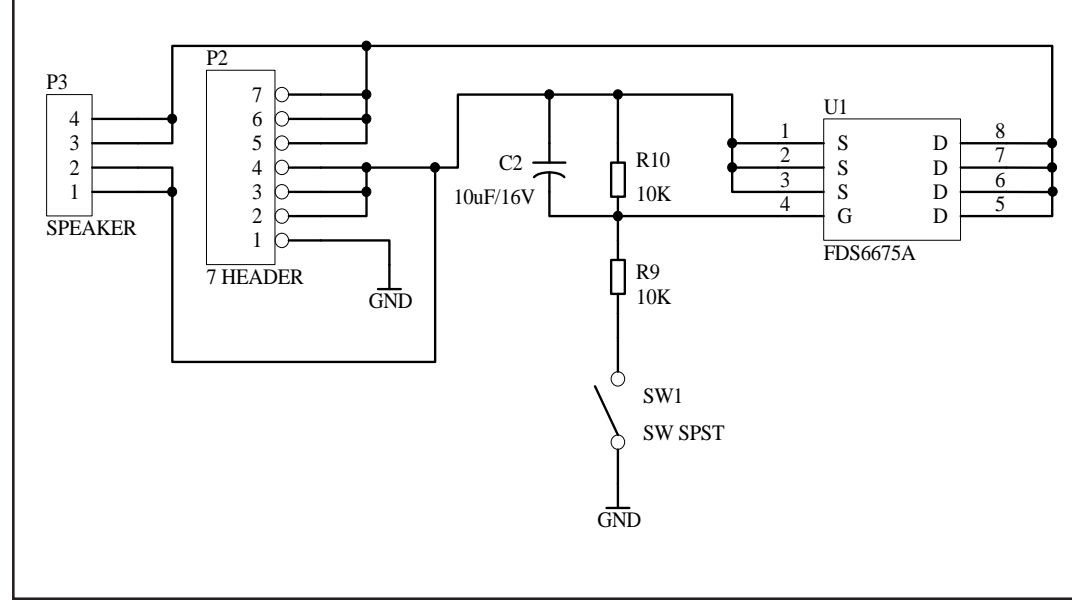

POWER

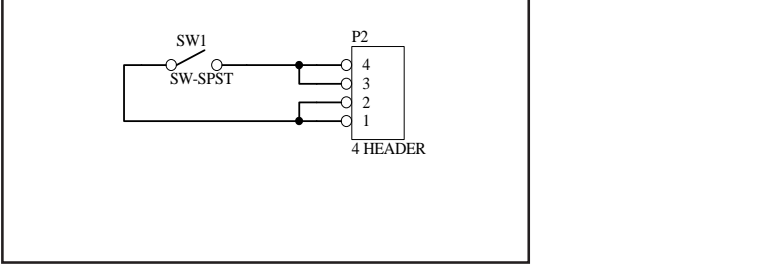

Components designated by the safety symbol should only be replaced by original parts produced and proofed by the manufacturer. Sicherheitsbauteile im Sinn der sicherheitsbestimmung. Diese Teile dürfen nur durch Originalteile ersetzt werden. Componenti di sicurezza. I componenti devono, corrispondere a ricambi originali e devono essere montati a regola d'arte.

L5A SPARE PART LIST

POSITION	BEKO CODE	PART DESCRIPTION
	056T14-AU1	LCD AU OPTRONICS T140VN01 14" LCD TV
	056T20-AU1	LCD AU A201SN01 V.3 (20" LCD TV)
	8R9107-AS	SPEAKER 4R 5W LCD TV
	8R9850-00A	ACCESSORIE BOX 17" LCD TV BEKO
	8R9953	POWER SWITCH LCD TV
	Y48120	L5 CHASIS 20" DAUGHTER BOARD L5A VER
	Y48121	L5A CHASIS 20" DAUGHTER BOARD CH CHI
	Y48913	ADAPTOR AC 15V 4.6A 20" CLASS II
	Y92913	ADAPTOR AC12V/5A CLASS II
	ZC5850-00A	ACCESSORIE BOX 20" LCD TV BEKO
	ZF9110	L5A CHASIS 14"TOS P/NX/1/K/S/VGA/NT A-OS
	ZF9187F	RC L5A TOSHIBA GRI/SHINE SI.P.ED CT-873
	ZG4110	L5A CHASIS 20"TOS AU P/NX/2/K/S/VGA/NT
	ZG4255-01	BACK COVER TOSH.BRI.SIL.P.20" LCDTV VGA
	ZH1183-CH1	INVERTOR 20" V201V1-T01 (PLCD0318604H)
	ZH6183-AU3	INVERTOR 14" AUO TAILON TLI-04-0411-A2
F600	054290	FUSE 5.0A 250V ROUND
IR1	452521-01	IR RECEIVER TSOP34838 SS1A
MENU	010844	TACT SWITCH 2 LEG (MTSB)
	ZC5502-AS	CABLE PANEL INTERFACE LCD20" CHIMEI
	Y56502-AS	KAB.PANEL INTERFACE LCD TV 15" MOLEX L5A
	ZC5513-AS	CABLE PANEL INVERTOR LCDTV FERRIT 20 CHI
	8R9100-AS	CABLE LCD POWER SWITCH L=350MM
S602	031274	JACK POWER HORIZONTAL
TU201	8R8138-PH1	TUNER FRONTEND PHILIPS FQ1216MEPT/I H-3
U100	452937	IC-CHIP VPC3230D-C5 QFP80 T&R
U301	453013	IC SDA5550 PLCC-84 TRAY
U304	452662-02	IC-CHIP AT24C16AN 10SI2.7 TAPE&REEL
U400	453010	IC -CHIP M24C02 - MN6T (4.5 - 5.5V) SO8
U401	453026	IC-CHIP MSP3410G PQFP80 T&R
U402	453021	IC TDA1517P
U403	452706-01	IC TDA1308T/N2 SO-G8 (T&R)
U500	453296	IC-CHIP GM2221 208PIN PQFP TRAY
U502	452662-02	IC-CHIP AT24C16AN 10SI2.7 TAPE&REEL
U600	453294	IC-CHIP LM2576D2TR4-005V 3A TO263 STPT&R
U602	401372	TRN FDS9933A
U603	453124	IC-CHIP NCP1117DT33RK TO-252 PACKAGE
U604	453124	IC-CHIP NCP1117DT33RK TO-252 PACKAGE
U605	453295	IC-CHIP NCP1117DT18RK TO252 (T&R)
Y100	056161	CRYSTAL 20.25MHZ HC49-U
Y300	056953	CRYSTAL 6MHZ CL 20PF
Y400	056952	CRYSTAL 18.432MHZ +-30PPM
Y500	056119	CRYSTAL 14.31818MHz CL=18PF30/30PPMH49U

FREQUENCY TABLE (MHz)

Channel	Number	BG	I	DK	L/L'
CH	1		49.75	49.75	47.75
CH	2	48.25	59.25	59.25	55.75
CH	3	55.25	77.25	77.25	60.50
CH	4	62.25	85.25	85.25	63.75
CH	5	175.25	93.25	93.25	176.00
CH	6	182.25	175.25	175.25	184.00
CH	7	189.25	183.25	183.25	192.00
CH	8	196.25	191.25	191.25	200.00
CH	9	203.25	199.25	199.25	208.00
CH	10	210.25	207.25	207.25	216.00
CH	11	217.25	215.25	215.25	189.25
CH	12	224.25	223.25	223.25	182.25
CH	13	53.75	45.75		196.25
CH	14	62.25	53.75		210.25
CH	15	82.25	61.75		
CH	16	175.25	69.75		
CH	17	183.25	95.25		
CH	18	192.25			
CH	19	201.25			
CH	20	210.25			
CH	21	471.25	471.25	471.25	471.25
CH	22	479.25	479.25	479.25	479.25
CH	23	487.25	487.25	487.25	487.25
CH	24	495.25	495.25	495.25	495.25
CH	25	503.25	503.25	503.25	503.25
CH	26	511.25	511.25	511.25	511.25
CH	27	519.25	519.25	519.25	519.25
CH	28	527.25	527.25	527.25	527.25
CH	29	535.25	535.25	535.25	535.25
CH	30	543.25	543.25	543.25	543.25
CH	31	551.25	551.25	551.25	551.25
CH	32	559.25	559.25	559.25	559.25
CH	33	567.25	567.25	567.25	567.25
CH	34	575.25	575.25	575.25	575.25
CH	35	583.25	583.25	583.25	583.25
CH	36	591.25	591.25	591.25	591.25
CH	37	599.25	599.25	599.25	599.25
CH	38	607.25	607.25	607.25	607.25
CH	39	615.25	615.25	615.25	615.25
CH	40	623.25	623.25	623.25	623.25
CH	41	631.25	631.25	631.25	631.25
CH	42	639.25	639.25	639.25	639.25
CH	43	647.25	647.25	647.25	647.25
CH	44	655.25	655.25	655.25	655.25

Channel	Number	BG	I	DK	L/L'
CH	45	663.25	663.25	663.25	663.25
CH	46	671.25	671.25	671.25	671.25
CH	47	679.25	679.25	679.25	679.25
CH	48	687.25	687.25	687.25	687.25
CH	49	695.25	695.25	695.25	695.25
CH	50	703.25	703.25	703.25	703.25
CH	51	711.25	711.25	711.25	711.25
CH	52	719.25	719.25	719.25	719.25
CH	53	727.25	727.25	727.25	727.25
CH	54	735.25	735.25	735.25	735.25
CH	55	743.25	743.25	743.25	743.25
CH	56	751.25	751.25	751.25	751.25
CH	57	759.25	759.25	759.25	759.25
CH	58	767.25	767.25	767.25	767.25
CH	59	775.25	775.25	775.25	775.25
CH	60	783.25	783.25	783.25	783.25
CH	61	791.25	791.25	791.25	791.25
CH	62	799.25	799.25	799.25	799.25
CH	63	807.25	807.25	807.25	807.25
CH	64	815.25	815.25	815.25	815.25
CH	65	823.25	823.25	823.25	823.25
CH	66	831.25	831.25	831.25	831.25
CH	67	839.25	839.25	839.25	839.25
CH	68	847.25	847.25	847.25	847.25
CH	69	855.25	855.25	855.25	855.25
CH	70		863,25		863.25
CH	71		871,25		
CH	72		879,25		
CH	73		887,25		160.00
CH	74	69.25			172.00
CH	75	76.25			220.00
CH	76	83.25			232.00
CH	77	90.25			244.00
CH	78	97.25			256.00
CH	79	59.25			268.00
CH	80	93.25			280.00
S	1	105.25	103.25	103.25	116.75
S	2	112.25	111.25	111.25	128.75
S	3	119.25	119.25	119.25	140.75
S	4	126.25	127.25	127.25	152.75
S	5	133.25	135.25	135.25	164.75
S	6	140.25	143.25	143.25	176.75
S	7	147.25	151.25	151.25	188.75
S	8	154.25	159.25	159.25	200.75
S	9	161.25	167.25	167.25	212.75
S	10	168.25	231.25	231.25	224.75
S	11	231.25	239.25	239.25	236.75
S	12	238.25	247.25	247.25	248.75
S	13	245.25	255.25	255.25	260.75
S	14	252.25	263.25	263.25	272.75

Channel	Number	BG	I	DK	L/L'
S	15	259.25	271.25	271.25	284.75
S	16	266.25	279.25	279.25	296.75
S	17	273.25	287.25	287.25	55.75
S	18	280.25	295.25	295.25	60.50
S	19	287.25	303.25	303.25	63.75
S	20	294.25			
S	21	303.25			303.25
S	22	311.25	311.25	311.25	311.25
S	23	319.25	319.25	319.25	319.25
S	24	327.25	327.25	327.25	327.25
S	25	335.25	335.25	335.25	335.25
S	26	343.25	343.25	343.25	343.25
S	27	351.25	351.25	351.25	351.25
S	28	359.25	359.25	359.25	359.25
S	29	367.25	367.25	367.25	367.25
S	30	375.25	375.25	375.25	375.25
S	31	383.25	383.25	383.25	383.25
S	32	391.25	391.25	391.25	391.25
S	33	399.25	399.25	399.25	399.25
S	34	407.25	407.25	407.25	407.25
S	35	415.25	415.25	415.25	415.25
S	36	423.25	423.25	423.25	423.25
S	37	431.25	431.25	431.25	431.25
S	38	439.25	439.25	439.25	439.25
S	39	447.25	447.25	447.25	447.25
S	40	455.25	455.25	455.25	455.25
S	41	463.25	463.25	463.25	463.25