

OPERATION AND SERVICE MANUAL

Model 2955, 2965, 2975

**MODEL 2955 (ENHANCED AC ONLY HIPOT WITH GROUND CONTINUITY CHECK)**  
**MODEL 2965 (ENHANCED AC/DC HIPOT WITH GROUND CONTINUITY CHECK)**  
**MODEL 2975 (ENHANCED AC/DC HIPOT WITH IR AND GROUND CONTINUITY)**

**SERIAL NUMBER**

--	--	--	--	--	--	--

*Models*  
*2955, 2965, 2975*

**Item 99-10571-01 Ver 1.07**

© Slaughter Company, Inc., 2012  
28105 N. Keith Drive  
Lake Forest, Illinois, 60045-4546  
U.S.A.

Printed October 19, 2012



## DECLARATION OF CONFORMITY

**Manufacturer:** Slaughter Company, Inc.

**Address:** 28105 N. Keith Drive  
Lake Forest, IL 60045  
USA

**Product Name:** Dielectric Withstand  
Voltage Tester

**Model Number:** 2955, 2965, 2975

**Conforms to the following Standards:**

**Safety:** UL 61010-1:2004  
IEC 61010-1: 2001  
IEC 61010-2-031: 1993

**EMC:** EN 61326-1:2006 (EN 55011:1998/A2:2002 Class A,  
EN 6100-3-2:2006,  
EN 61000-3-3:1995/A1:2001/A2:2005,  
IEC 61000-4-2:1995/A2:2000, IEC 61000-4-3:2001,  
IEC 61000-4-4:2004, IEC 61000-4-5:1995/A1:2000,  
IEC 61000-4-6:2003, IEC 61000-4-8:1993/A1:2000,  
IEC 61000-4-11:2004)

**Supplementary Information**

*The product herewith complies with the requirements of the **Low Voltage Directive 73/23/EEC as amended by 93/68/EEC** and the **EMC Directive 89/336/EEC as amended by 92/31/EEC**.*

*The CE marking has been affixed on the device according to article 10 of the EMC Directive 8/336/EEC.*

*The technical file and other documentation are on file with Associated Research, Inc.*

Joseph Guerriero  
Vice President / General Manager

Slaughter Company, Inc.  
Lake Forest, Illinois USA  
August 20, 2009



## **Warranty Policy**

Slaughter Company, certifies that the instrument listed in this manual meets or exceeds published manufacturing specifications. This instrument was calibrated using standards that are traceable to the National Institute of Standards and Technology (NIST).

Your new instrument is warranted to be free from defects in workmanship and material for a period of (1) year from date of shipment. You must return the “Owners Registration Card” provided within (15) days from receipt of your instrument.

Slaughter Company recommends that your instrument be calibrated on a twelve-month cycle. A return material authorization (RMA) must be obtained from Slaughter Company. Please contact our Customer Support Center at 1-800-504-0055 to obtain an RMA number. It is important that the instrument is packed in its original container for safe transport. If the original container is not available please contact our customer support center for proper instructions on packaging. Damages sustained as a result of improper packaging will not be honored. Transportation costs for the return of the instrument for warranty service must be prepaid by the customer. Slaughter Company will assume the return freight costs when returning the instrument to the customer. The return method will be at the discretion of Slaughter Company.

Except as provided herein, Slaughter Company makes no warranties to the purchaser of this instrument and all other warranties, express or implied (including, without limitation, merchantability or fitness for a particular purpose) are hereby excluded, disclaimed and waived.

Any non-authorized modifications, tampering or physical damage will void your warranty. Elimination of any connections in the earth grounding system or bypassing any safety systems will void this warranty. This warranty does not cover batteries or accessories not of Slaughter Company manufacture. Parts used must be parts that are recommended by Slaughter Company as an acceptable specified part. Use of non-authorized parts in the repair of this instrument will void the warranty.

# TABLE OF CONTENTS

<b>SECTION I OPERATORS MANUAL.....</b>	<b>1</b>
SAFETY .....	2
INTRODUCTION .....	6
SPECIFICATIONS .....	12
CONTROLS .....	18
INSTALLATION.....	22
QUICK START .....	26
OPERATION.....	29
OPTIONS .....	53
<b>SECTION II SERVICE MANUAL .....</b>	<b>56</b>
CALIBRATION.....	57
PARTS LIST.....	62
SCHEMATICS .....	64



**SECTION 1**  
**OPERATORS MANUAL**

## **SAFETY PRECAUTIONS REQUIRED FOR HIGH VOLTAGE TESTING!**

### GENERAL:

This product and its related documentation must be reviewed for familiarization with safety markings and instructions before operation.

This product is a Safety Class I instrument (provided with a protective earth terminal).

Before applying power verify that the instrument is set to the correct line voltage (115 or 230) and the correct fuse is installed.



INSTRUCTION MANUAL SYMBOL. PLEASE REFER TO THE INSTRUCTION MANUAL FOR SPECIFIC WARNING OR CAUTION INFORMATION TO AVOID PERSONAL INJURY OR DAMAGE TO THE PRODUCT.



INDICATES HAZARDOUS VOLTAGES MAY BE PRESENT.

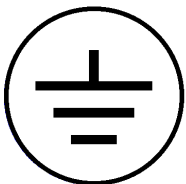

CHASSIS GROUND SYMBOL.



CALLS ATTENTION TO A PROCEDURE, PRACTICE, OR CONDITION, THAT COULD POSSIBLY CAUSE BODILY INJURY OR DEATH.



CALLS ATTENTION TO A PROCEDURE, PRACTICE, OR CONDITION, THAT COULD POSSIBLY CAUSE DAMAGE TO EQUIPMENT OR PERMANENT LOSS OF DATA.



A Hipot produces voltages and currents which can cause **harmful or fatal electric shock**. To prevent accidental injury or death, these safety procedures must be strictly observed when handling and using the test instrument.

#### **SERVICE AND MAINTENANCE**

##### User Service

To prevent electric shock do not remove the instrument cover. There are no user serviceable parts inside. Routine maintenance or cleaning of internal parts is not necessary. Any external cleaning should be done with a clean dry or slightly damp cloth. Avoid the use of cleaning agents or chemicals to prevent any foreign liquid from entering the cabinet through ventilation holes or damaging controls and switches, also some chemicals may damage plastic parts or lettering. Schematics, when provided, are for reference only. Any replacement cables and high voltage components should be acquired directly from Slaughter Company, Inc. Refer servicing to a Slaughter Company, Inc. authorized service center.

SLAUGHTER COMPANY, INC.  
28105 N. KEITH DRIVE  
LAKE FOREST, IL 60045-4546 U.S.A.

( PHONE: 1 (847) 932-3662  
**1 (800) 504-0055**  
FAX: 1 (847) 932-3665  
E-MAIL : support@hipot.com  
www.hipot.com

##### Service Interval

The instrument and its power cord, test leads, and accessories must be returned at least once a year to a Slaughter Company authorized service center for calibration and inspection of safety related components. Slaughter Company will not be held liable for injuries suffered if the instrument is not returned for its annual safety check and maintained properly.

##### User Modifications

Unauthorized user modifications will void your warranty. Slaughter Company will not be responsible for any injuries sustained due to unauthorized equipment modifications or use of parts not specified by Slaughter Company. Instruments returned to Slaughter Company with unsafe modifications will be returned to their original operating condition at your expense.

#### **TEST STATION**

##### Location

Select an area away from the main stream of activity which employees do not walk through in performing their normal duties. If this is not practical because of production line flow, then the area should be roped off and marked for **HIGH VOLTAGE TESTING**. No employees other than the test operators should be allowed inside.

If benches are placed back-to-back, be especially careful about the use of the bench opposite the test station. Signs should be posted: "**DANGER - HIGH VOLTAGE TEST IN PROGRESS - UNAUTHORIZED PERSONNEL KEEP AWAY.**"

#### Power

Dielectric Voltage-Withstand Test Equipment must be connected to a good ground. Be certain that the power wiring to the test bench is properly polarized and that the proper low resistance bonding to ground is in place.

Power to the test station should be arranged so that it can be shut off by one prominently marked switch located at the entrance to the test area. In the event of an emergency, anyone can cut off the power before entering the test area to offer assistance.

#### Work Area

Perform the tests on a nonconducting table or workbench, if possible.

There should not be any metal in the work area between the operator and the location where products being tested will be positioned.

Position the tester so the operator does not have to reach over the product under test to activate or adjust the tester. If the product or component being tested is small, it may be possible to construct guards or an enclosure, made of a non-conducting material such as clear acrylic, such that the item being tested is within the guards or enclosure during the test, and fit them with switches so that the tester will not operate unless the guards are in place or the enclosure closed.

Keep the area clean and uncluttered. All test equipment and test leads not absolutely necessary for the test should be removed from the test bench and put away. It should be clear to both the operator and to any observers which product is being tested, and which ones are waiting to be tested or have already been tested.

Do not perform Hipot tests in a combustible atmosphere or in any area where combustible materials are present.

### **TEST OPERATOR**

#### Qualifications

This instrument generates voltages and currents which can cause **harmful or fatal electric shock** and must only be operated by a skilled worker trained in its use.

The operator should understand the electrical fundamentals of voltage, current, and resistance.

#### Safety Procedures

Operators should be thoroughly trained to follow these and all other applicable safety rules and procedures before they begin a test. Defeating any safety system should be treated as a serious offense and should result in severe penalties, such as removal from the Hipot testing job. Allowing unauthorized personnel in the area during a test should also be dealt with as a serious offense.

---

Dress

Operators should not wear jewelry which could accidentally complete a circuit.

Medical Restrictions

This instrument should not be operated by personnel with heart ailments or devices such as pacemakers.

**TEST PROCEDURES****!NEVER PERFORM A HIPOT TEST ON ENERGIZED CIRCUITRY OR EQUIPMENT!**

If the instrument has an external safety-ground connection be sure that this is connected. Then connect the return lead **first** for any test regardless of whether the item under test is a sample of insulating material tested with electrodes, a component tested with the high voltage test lead, or a cord-connected device with a two or three-prong plug.

Plug in the high voltage test lead only when it is being used. Handle its clip only by the insulator---**never touch the clip directly**. Be certain that the operator has control over any remote test switches connected to the Hipot. Double-check the return and high voltage connections to be certain that they are proper and secure.

**NEVER TOUCH THE ITEM UNDER TEST OR ANYTHING CONNECTED TO IT WHILE HIGH VOLTAGE IS PRESENT DURING THE HIPOT TEST.**

**WARNING**

When testing with DC, always discharge the capacitance of the item under test and anything the high voltage may have contacted--such as test fixtures--before handling it or disconnecting the test leads.

**HOT STICK** probes can be used to discharge any capacitance in the item under test as a further safety precaution. A hot stick is a nonconducting rod about two feet long with a metal probe at the end which is connected to a wire. To discharge the device under test, two hot sticks are required. First connect both probe wires to a good earth ground. Then touch one probe tip to the same place the return lead was connected. While holding the first probe in place, touch the second probe tip to the same place where the high voltage lead was connected.

**KEY SAFETY POINTS TO REMEMBER:**

- Keep unqualified and unauthorized personnel away from the test area.
- Arrange the test station in a safe and orderly manner.
- Never touch the product or connections during a test.
- In case of any problem, turn off the high voltage first.
- Properly discharge any item tested with DC before touching connections.

## GLOSSARY OF TERMS

(as used in this manual)

**Alternating Current, AC:** Current which reverses direction on a regular basis, commonly in the U.S.A. 60 times per second, in other countries 50 times per second.

**Breakdown:** The failure of insulation to effectively prevent the flow of current, sometimes evident by arcing. If voltage is gradually raised, breakdown will begin suddenly at a certain voltage level. Current flow is not directly proportional to voltage. Once breakdown current has flown, especially for a period of time, a repeated application of voltage will often show breakdown beginning at a lower voltage than initially.

**Conductive:** Having a volume resistivity of no more than  $10^3$  ohm-cm or a surface resistivity of no more than  $10^5$  ohms per square.

**Conductor:** A solid or liquid material which has the ability to let current pass through it, and which has a volume resistivity of no more than  $10^3$  ohm-cm.

**Current:** The movement of electrons through a conductor. Current is measured in amperes, milliamperes, microamperes, nanoamperes, or picoamperes. Symbol = **I**

**Dielectric:** An insulating material which is positioned between two conductive materials in such a way that a charge or voltage may appear across the two conductive materials.

**Direct Current, DC:** Current which flows in one direction only. The source of direct current is said to be polarized and has one terminal which is always at a higher potential than the other.

**Hipot Tester:** Common term for dielectric-withstand test equipment.

**Insulation:** Gas, liquid or solid material which has a volume resistivity of at least  $10^{12}$  ohm-cm and is used for the purpose of resisting current flow between conductors.

**Insulation Resistance Tester:** An instrument or a function of an instrument capable of measuring resistance's in excess of 200 megohms. Usually employs a higher voltage power supply than used in ohmmeters measuring up to 200 megohms.

**Leakage:** AC or DC current flow through insulation and over its surfaces, and AC current flow through a capacitance. Current flow is directly proportional to voltage. The insulation and/or capacitance is thought of as a constant impedance, unless breakdown occurs.

**Resistance:** That property of a substance which impedes current and results in the dissipation of power in the form of heat. The practical unit of resistance is the *ohm*. Symbol = **R**

**Trip Point:** The minimum current flow required to cause an indication of unacceptable performance during a dielectric voltage-withstand test.

**Voltage:** Electrical pressure, the force which causes current through an electrical conductor.  
Symbol = **V**

## INTRODUCTION

### **The importance of testing... User safety**

In an era of soaring liability costs, original manufacturers of electrical and electronic products must make sure every item is as safe as possible. All products must be designed and built to prevent electric shock, even when users abuse the equipment or bypass built in safety features.

To meet recognized safety standards, one common test is the "dielectric voltage-withstand test". Safety agencies which require compliance safety testing at both the initial product design stage and for routine production line testing include: Underwriters Laboratories, Inc. (UL), the Canadian Standards Association (CSA), the International Electrotechnical Commission (IEC), the British Standards Institution (BSI), the Association of German Electrical Engineers (VDE), the Japanese Standards Association (JSI). These same agencies may also require that an insulation resistance test and high current ground bond test be performed.

### **The Dielectric Withstand (Hipot) Test....**

The principle behind a dielectric voltage - withstand test is simple. If a product will function when exposed to extremely adverse conditions, it can be assumed that the product will function in normal operating circumstances.

The most common applications of the dielectric-withstand test are:

- Design (performance) Testing.... determining design adequacy to meet service conditions.
- Production Line Testing.... detecting defects in material or workmanship during processing.
- Acceptance Testing.... proving minimum insulation requirements of purchased parts.
- Repair Service Testing.... determine reliability and safety of equipment repairs.

The specific technique varies with each product, but basically, during a dielectric voltage - withstand test, an electrical device is exposed to a voltage significantly higher than it normally encounters. The high voltage is continued for a given period.

If, during the time the component is tested, stray current flow remains within specified limits, the device is assumed safe under normal conditions. The basic product design and use of the insulating material will protect the user against electrical shock.

The equipment used for this test, a dielectric-withstand tester, is often called a "hipot" (for high potential tester). The "rule of thumb" for testing is to subject the product to twice its normal operating voltage, plus 1,000 volts.

However, specific products may be tested at much higher voltages than 2X operating voltages + 1,000 volts. For example, a product designed to operate in the range between 100 to 240 volts, can be tested between 1,000 to 4,000 volts or higher. Most "double insulated" products are tested at voltages much higher than the "rule of thumb".

Testing during development and prototype stages is more stringent than production run tests because the basic design of the product is being evaluated. Design tests usually are performed on only a few samples of the product. Production tests are performed on each and every item as it comes off the production line.

The hipot tester must also maintain an output voltage between 100% and 120% of specification. The output voltage of the hipot must have a sinusoidal waveform with a frequency between 40 to 70 Hz and has a peak waveform value that is not less than 1.3 and not more than 1.5 times the root-mean-square value.

### **Advantages and Disadvantages of AC Testing and DC Testing....**

Please check with the Compliance Agency you are working with to see which of the two types of voltages you are authorized to use. In some cases, a Compliance Agency will allow either AC or DC testing to be done. However, in other cases the Compliance Agency only allows for an AC test. If you are unsure which specification you must comply with please contact our **CUSTOMER SUPPORT GROUP at 1-800-504-0055**.

Many safety agency specifications allow either AC or DC voltages to be used during the hipot test. When this is the case, the manufacturer must make the decision on which type of voltage to utilize. In order to do this it is important to understand the advantages and the disadvantages of both AC and DC testing.

#### AC testing characteristics

Most items that are hipot tested have some amount of distributed capacitance. An AC voltage cannot charge this capacitance so it continually reads the reactive current that flows when AC is applied to a capacitive load.

#### AC testing advantages

1. AC testing is generally much more accepted by safety agencies than DC testing. The main reason for this is that most items being hipot tested will operate at AC voltages and AC hipot testing offers the advantage of stressing the insulation alternately in both polarities which more closely simulates stresses the product will see in real use.
2. Since AC testing cannot charge a capacitive load the current reading remains consistent from initial application of the voltage to the end of the test. Therefore, there is no need to gradually bring up the voltage since there is no stabilization required to monitor the current reading. This means that unless the product is

sensitive to a sudden application of voltage the operator can immediately apply full voltage and read current without any wait time.

3. Another advantage of AC testing is that since AC voltage cannot charge a load there is no need to discharge the item under test after the test.

#### AC testing disadvantages

1. A key disadvantage of AC testing surfaces when testing capacitive products. Again, since AC cannot charge the item under test, reactive current is constantly flowing. In many cases, the reactive component of the current can be much greater than the real component due to actual leakage. This can make it very difficult to detect products that have excessively high leakage current.
2. Another disadvantage of AC testing is that the hipot has to have the capability of supplying reactive and leakage current continuously. This may require a current output that is actually much higher than is really required to monitor leakage current and in most cases is usually much higher than would be needed with DC testing. This can present increased safety risks as operators are exposed to higher currents.

#### DC testing characteristics

During DC hipot testing the item under test is charged. The same test item capacitance that causes reactive current in AC testing results in initial charging current which exponentially drops to zero in DC testing.

#### DC testing advantages

1. Once the item under test is fully charged the only current flowing is true leakage current. This allows a DC hipot tester to clearly display only the true leakage of the product under test.
2. The other advantage to DC testing is that since the charging current only needs to be applied momentarily the output power requirements of the DC hipot tester can typically be much less than what would be required in an AC tester to test the same product.

#### DC testing disadvantages

1. Unless the item being tested has virtually no capacitance it is necessary to raise the voltage gradually from zero to the full test voltage. The more capacitive the item the more slowly the voltage must be raised. This is important since most DC hipots have failure shut off circuitry which will indicate failure almost immediately if the total current reaches the leakage threshold during the initial charging of the product under test.

2. Since a DC hipot does charge the item under test it becomes necessary to discharge the item after the test.
3. DC testing unlike AC testing only charges the insulation in one polarity. This becomes a concern when testing products that will actually be used at AC voltages. This is a key reason that some safety agencies do not accept DC testing as an alternative to AC.
4. When performing AC hipot tests the product under test is actually tested with peak voltages that the hipot meter does not display. This is not the case with DC testing since a sinewave is not generated when testing with direct current. In order to compensate for this most safety agencies require that the equivalent DC test be performed at higher voltages than the AC test. The multiplying factor is somewhat inconsistent between agencies which can cause confusion concerning exactly what equivalent DC test voltage is appropriate.

### **The Ground Continuity Test**

The Ground Continuity test is checking to verify that there is low impedance path between the chassis and the safety ground wire of the line cord. A low impedance ground system is critical in ensuring that in the event of a product failure a circuit breaker on the input line will act quickly to protect the user from any serious electrical shock.

International compliance agencies such as CSA, IEC, TÜV, VDE, BABT, and others, have requirements calling out this test. A low current test merely indicates that there is a safety ground connection, it does not completely test the integrity of that connection that would be accomplished when using much higher currents in the range from 10 to 30amps. The high current test is known as a Ground Bond test.

The Ground Continuity test verifies that the ground circuit between the Continuity and Return panel jacks on the Hipot is below 1ohm while test at a current of 100mA. This function can be enabled or disabled through software, when a ground circuit is not provided on the device under test or test requirement are not needed.

### **The Insulation Resistance Test...**

Some "dielectric analyzers today come with a built in insulation resistance tester. Typically, the IR function provides test voltages from 500 to 1,000 volts DC and resistance ranges from kilohms to gigaohms. This function allows manufacturers to comply with special compliance regulations. BABT, TÜV, and VDE are agencies that may under certain conditions require an IR test on the product before a Hipot test is performed. This typically is not a production line test but a performance design test.

The insulation resistance test is very similar to the hipot test. Instead of the go/no go indication that you get with a hipot test the IR test gives you an insulation value usually in Megohms. Typically the higher the insulation resistance value the better the condition of the insulation. The connections to perform the IR test are the same as the hipot test. The



measured value represents the equivalent resistance of all the insulation which exists between the two points and any component resistance which might also be connected between the two points.

Although the IR test can be a predictor of insulation condition, it does not replace the need to perform a Dielectric Withstand test.

#### **TYPES OF FAILURES DETECTABLE ONLY WITH A HIPOT TEST**

- Weak Insulating Materials
- Pinholes in Insulation
- Inadequate Spacing of Components
- Pinched Insulation

<p><b>IF YOU SHOULD HAVE ANY QUESTIONS RELATING TO THE OPERATION OF YOUR INSTRUMENT CALL 1 (800) 504-0055 IN THE U.S.A.</b></p>
---

## Model 2955, 2965, and 2975 Functional Specifications

Unless otherwise stated, accuracy's are relative to a laboratory standard measurement.

<b>DIELECTRIC WITHSTAND TEST MODE</b>	
Descriptions	Specifications
INPUT VOLTAGE	115 / 230V selectable, $\pm 15\%$ variation
FREQUENCY	50 / 60 Hz $\pm 5\%$
FUSE	2A / 250 V Fast acting 250VAC
OUTPUT	Rating AC 0 - 5000V, 12mA DC 0 - 6000V, 5mA (DC mode on 2965 and 2975) Regulation : $\pm (1\% \text{ of output} + 5V)$
VOLTAGE SETTING	0V - Max output rating Resolution : 0.01kV Accuracy : $\pm (2\% \text{ of Setting} + 5V)$ (relative to displayed output) Can be adjusted during operation via UP and DOWN arrow keys.
OUTPUT FREQUENCY	2955 : 50 / 60 Hz selectable 2965 and 2975 : DC and 50 / 60 Hz selectable Accuracy: $\pm 0.1\%$
WAVE FORM	Sinewave, Distortion : $< 2\%$ THD
DC OUTPUT RIPPLE	$< 5\%$ at 6KVDC / 5mA, resistive load (2965 and 2975)
DWELL TIME SETTING	0 and 0.2 - 999.9 seconds, 0.1 second / step "0" for continuous running
RAMP TIME SETTING	Model 2955, 2965, and 2975 0 and 0.2 - 999.9 seconds, 0.1 second / step 0 ramp setting = 0.1 seconds fixed ramp  Model 2955 Ramp = 0.1 seconds fixed
FAILURE SETTINGS	AC mode High limit : 0.10 - 12.00 mA, 0.01 mA / step Low limit : 0.00, 0.10 - 12.00 mA, 0.01 mA / step (0= OFF) (2955, 2965, and 2975) Accuracy : $\pm (2\% \text{ of setting} + 0.02 \text{ mA})$  DC mode High limit : 0.02 - 5.00 mA, 0.01 mA / step Low limit : 0.00, 0.02 - 5.00 mA, 0.01 mA / step (0= OFF) (2965, and 2975) Accuracy : $\pm (2\% \text{ of setting} + 0.02 \text{ mA})$

Descriptions	Specifications																		
METERING	Voltmeter (4 digits) Range : AC 0.00 - 5.00 KV : DC 0.00 - 6.00 KV Resolution : .01 KV Accuracy : $\pm$ (2 % of reading + 5 V) Ammeter (4 digits) Range : AC 0.10 - 12.00 mA : DC 0.02 - 5.00 mA Resolution : 0.01 mA Accuracy : $\pm$ (2 % of reading + 0.02mA)																		
TIMER DISPLAY	Range : 0.0 - 999.9 seconds Resolution : 0.1 second Accuracy : $\pm$ (0.1 % of reading + 0.05 seconds)																		
DISCHARGE TIME	$\leq$ 200 ms The maximum capacitive load vs. output voltage : 1.0 $\mu$ F --- < 1KV            0.080 $\mu$ F --- < 4KV 0.75 --- < 2KV                0.040 $\mu$ F --- < 5KV 0.50 $\mu$ F --- < 3KV            0.010 $\mu$ F --- < 6KV																		
GROUND CONTINUITY CHECK	Current : DC 0.1 A $\pm$ 0.01A, fixed Ranges: HI-Limit: 0.00 – 1.50 $\Omega$ Lo-Limit: 0.01 – 1.50 $\Omega$ Offset: 0.00 – 0.50 $\Omega$ Resolution: 0.1 $\Omega$ Accuracy: $\pm$ ( 2% of setting + 0.02 $\Omega$ )																		
<b>INSULATION RESISTANCE TEST MODE</b>																			
Output Voltage	Range: 100 - 1000 Volts DC Resolution: 10 volt/step Accuracy: $\pm$ (2% of reading + 5V)																		
Voltage Display	Range: 100 - 1000 V Resolution: 10 volt/step Accuracy: $\pm$ (2% of reading + 5V)																		
Resistance Display	Range: 1 - 1000 M $\Omega$ (4 Digit, Auto Ranging) Resolution: <table style="margin-left: 100px; border: none;"> <tr> <td></td> <td style="text-align: center;">500VDC</td> <td style="text-align: center;">1000VDC</td> </tr> <tr> <td></td> <td style="text-align: center;">M<math>\Omega</math></td> <td style="text-align: center;">M<math>\Omega</math></td> </tr> <tr> <td></td> <td style="text-align: center;">0.01</td> <td style="text-align: center;">1.00 - 40.00</td> </tr> <tr> <td></td> <td style="text-align: center;">0.1</td> <td style="text-align: center;">35.0 - 999.9</td> </tr> <tr> <td></td> <td></td> <td style="text-align: center;">1.00 - 80.00</td> </tr> <tr> <td></td> <td></td> <td style="text-align: center;">75.0 - 999.9</td> </tr> </table>		500VDC	1000VDC		M $\Omega$	M $\Omega$		0.01	1.00 - 40.00		0.1	35.0 - 999.9			1.00 - 80.00			75.0 - 999.9
	500VDC	1000VDC																	
	M $\Omega$	M $\Omega$																	
	0.01	1.00 - 40.00																	
	0.1	35.0 - 999.9																	
		1.00 - 80.00																	
		75.0 - 999.9																	

	<p>Accuracy: <math>\pm</math> (3% of reading + 2 counts) at test voltage &gt; 500V</p> <p><math>\pm</math> (7% of reading + 2 counts) at test voltage <math>\leq</math> 500V</p>
--	--

Descriptions	Specifications
High Resistance Limit	Range: 0, and 1 - 1000 M $\Omega$ (0 = Off)
Low Resistance Limit	Range: 1 - 1000 M $\Omega$
Delay Timer	Range: 0, 0.02 - 999.9 sec (0 = Continuous)
	Resolution: 0.1 sec/step
	Accuracy: $\pm$ (0.1% + 0.05 sec)

**GENERAL**

REMOTE CONTROL AND SIGNAL OUTPUT	The following input and output signals are provided through the 9 pin D type connector; <ol style="list-style-type: none"> <li>1. Remote control : test, reset, interlock</li> <li>2. Outputs : pass, fail and test in process</li> </ol>
PROGRAM MEMORY	10 memories, 4 Test Modes Selectable (W, I, W-I, I-W)
SECURITY	Key Lock capability to avoid unauthorized access to all test parameters. Memory Lock capability to avoid unauthorized access to memory locations.
LINE CORD	Detachable 7 ft. (2.13m) power cable terminated in a three-prong grounding plug.
TERMINATIONS	6ft.(1.80m) high voltage and return leads (2) with clips. An optional remote receptacle box may be purchased for testing items terminated with a line cord. International receptacles are also available.
MECHANICAL	Tilt up front feet. Dimensions: (W x H x D) 11 x 3.5 x 11.81 in. (280 x 89 x 300 mm) Weight: 20 lbs (9 Kgs)
ENVIRONMENTAL	Operating Temperature : 32° - 104°F (0° - 40°C) Relative Humidity - 20 to 80%
CALIBRATION	Traceable to National Institute of Standards and Technology (NIST). Calibration controlled by software. Adjustments are made through front panel keypad in a restricted access calibration mode. Calibration information stored in non-volatile memory.

---

**KEY FEATURES & BENEFITS OF MODELS 2955, 2965, and 2975**

1. No load setup of trip current and output voltage.  
*This provides the operator with an easy and safe way to set trip currents and output voltages since parameters are set without the high voltage activated.*
2. Automatic storage of test program.  
*The 2900 family powers-up with the parameters that were used during the last test to avoid operator set-up errors.*
3. All parameters for the setups can be adjusted through a simple menu driven program.  
*The easy to follow setup screens ensure that the operator correctly sets up all test parameters.*
4. Tamper proof front panel controls.  
*This makes it possible to limit user access to the setup screens so that only authorized personnel with a security code can change test parameters.*
5. Line and load regulation.  
*This system maintains the output voltage to within 1% from no load to full load and over the line voltage range to ensure that test results remain consistent and within safety agency requirements..*
6. The LCD display allows monitoring of current down to 100 microamps AC and 20 microamps DC.  
*This allows the 2900 series of Hipots to be used even when test requirements only allow a very low level of acceptable leakage current.*
7. Electronic dwell settings.  
*The electronic dwell control helps keep test results consistent by ensuring that the test duration is the same for each product tested.*
8. PLC remote inputs and outputs.  
*The standard 9- pin interfaces provide outputs for Pass, Fail, Test in Process and Interlock. Inputs include Test and Reset. This gives the user all the basic remotes required to configure the Hipot through simple PLC relay control.*
9. Front panel LCD displays test parameters and results.  
*A front panel LCD allows the operator to monitor the test. The display holds the results after a test item failure so that the operator can easily review the test results. Indications of high fail and continuity failure are clearly displayed.*
10. Maximum output current 12 milliamps AC and 5 milliamps DC.  
*This makes this instrument a **true** hipot tester with enough output current to test capacitive loads in AC mode and allows the instrument to comply with the UL "120 K ohm" requirements.*

11. Software calibration control.  
*The 2900 family of Hipots is calibrated through the front panel keypad. All calibration information is stored in non-volatile memory. This allows the instrument to be completely calibrated without removing any covers and exposing the technician to hazardous voltages.*
  
12. User selectable output voltage frequencies of 50 or 60 hertz.  
*The 2900 family of Hipots was designed for the global market. This feature makes it simple for the user to select the output frequency in the AC hipot mode so that products can be tested at the same frequency they will be used.*
  
13. Output voltage fine adjustment.  
*To make The 2900 family of Hipots usable in all types of applications, the operator can manually bring the voltage up or down in 10 volt increments by simply pressing the up and down arrow keys. This makes it very easy to adjust the output voltage even while the instrument is in the dwell mode so you can analyze test results at different voltages.*
  
14. Built-in Adjustable Continuity test mode.  
*The 2900 family of Hipots meets ground continuity test requirements called out by UL and other safety agencies.*
  
15. Flashing high voltage indicator.  
*A flashing LED located directly over the high voltage terminal clearly indicates when high voltage is active to provide maximum operator safety.*
  
16. User selectable input voltage.  
*The 2900 family of Hipots can be switched for either 115 or 230 volt input operation through an easy access rear panel mounted switch to allow it to be used in any country.*
  
17. Low-current sense.  
*Monitors the minimum level of current flow, thus ensuring that the DUT is properly connected and that the hipot test is being performed.*
  
18. Electronic ramping.  
*Provides a gradual and timed method to increase output voltage to the DUT, minimizing any damage from quickly over-applying high voltage to sensitive DUTs.*
  
19. Test setup memories.  
*The operator can store and recall test setups, thus eliminating the need to re-enter setup information.*

20. Insulation Resistance Test Mode \*

*This allows the operator to perform an Insulation Resistance test independently or in sequence with the Dielectric Withstand (Hipot) test, thus eliminating the need for a separate piece of test equipment when IR testing is required.*

21. Insulation Resistance Adjustable Output \*

*The Insulation Resistance test mode provides an adjustable output range of 100-1000 volts DC. This gives the user the ability to meet most IR test requirements.*

\* Only available on model 2975

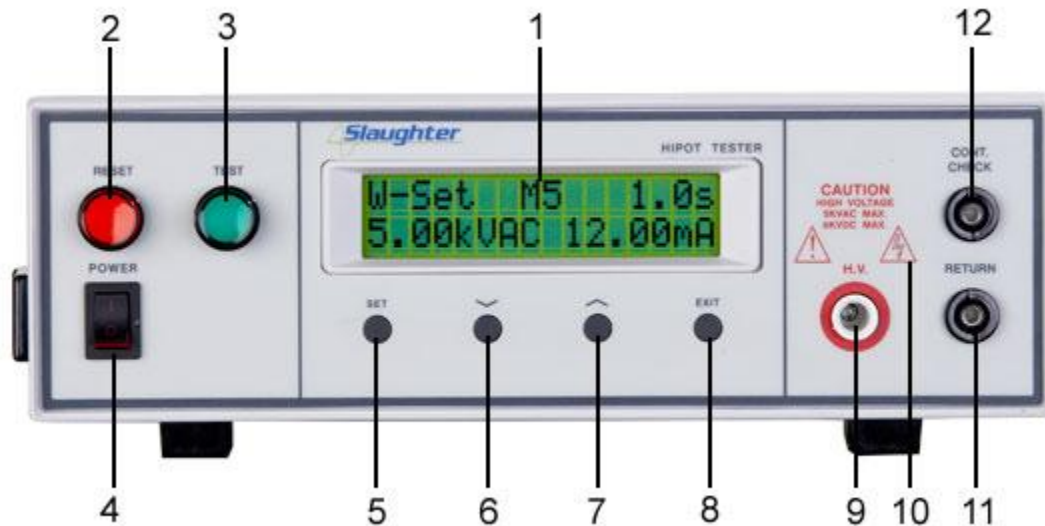
**FRONT PANEL CONTROLS**

- 1. LCD DISPLAY:** The Liquid Crystal Display is the main readout for the operator and programmer of the test settings and test results.
- 2. RESET SWITCH:** This is a momentary contact switch. If an out-of-range reading is detected during a hipot test or an IR test or if continuity failure occurs, the red failure lamp within the switch will light. To reset the system for the next test, press and release this switch. This switch may also be used to abort a test in progress.
- 3. TEST SWITCH:** This is a momentary contact switch. Press the green switch to turn on the high voltage output when in test mode. The indicator lamp within the switch will light when continuity is “good”, if continuity mode is enabled.
- 4. POWER SWITCH:** Rocker-style switch with international ON ( | ) and OFF ( 0 ) markings.
- 5. SET KEY:** Use this key to advance forward through the setup menus.
- 6. DOWN ARROW (∨):** Use this key to decrement numeric values in the setup mode. This key also used to toggle ON/OFF functions. Also may be used to decrease output voltage during a test in 10-volt increments.



## FRONT PANEL CONTROLS

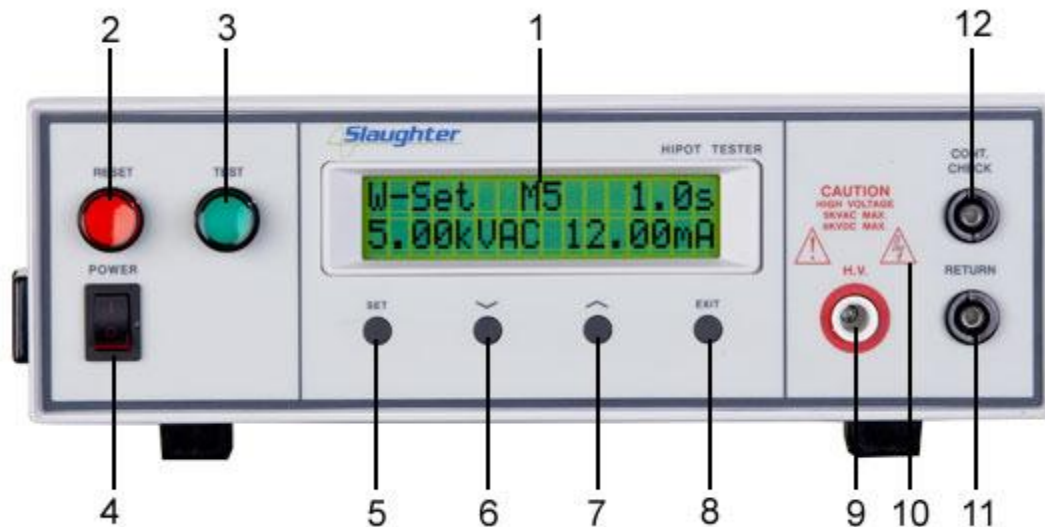

7. **UP ARROW (^):** Use this key to increment numeric values in the setup mode. This key also used to toggle ON/OFF functions. Also may be used to increase output voltage during a test in 10-volt increments.
8. **EXIT KEY:** Use this key when you desire to enter the **Run Mode** to initiate a test.
9. **HIGH VOLTAGE OUTPUT JACK:** For the connection of the detachable 5-foot (1.52 m) red high voltage test lead. The silicone rubber insulation is flexible for easy handling and is rated at 30KVDC. The jack is recessed for safety when this lead is not being used.
10. **HIGH VOLTAGE ARROW (LED INDICATOR):** This indicator flashes to warn the operator that high voltage is present at the high voltage output terminal.
11. **RETURN OUTPUT JACK:** For the connection of the detachable 5 foot (1.52 m) black return test lead or three-prong receptacle adapter box. This jack is always used when performing a test. Please refer section E. Adapter Box connection for details on connecting the adapter box between the instrument and the device under test.
12. **CONTINUITY CHECK OUTPUT JACK:** For the connection of the detachable 5 foot (1.52 m) black return test lead. This jack is always used when performing a continuity test. Please refer section E. Adapter Box connection for details on connecting the adapter box between the instrument and the device under test.

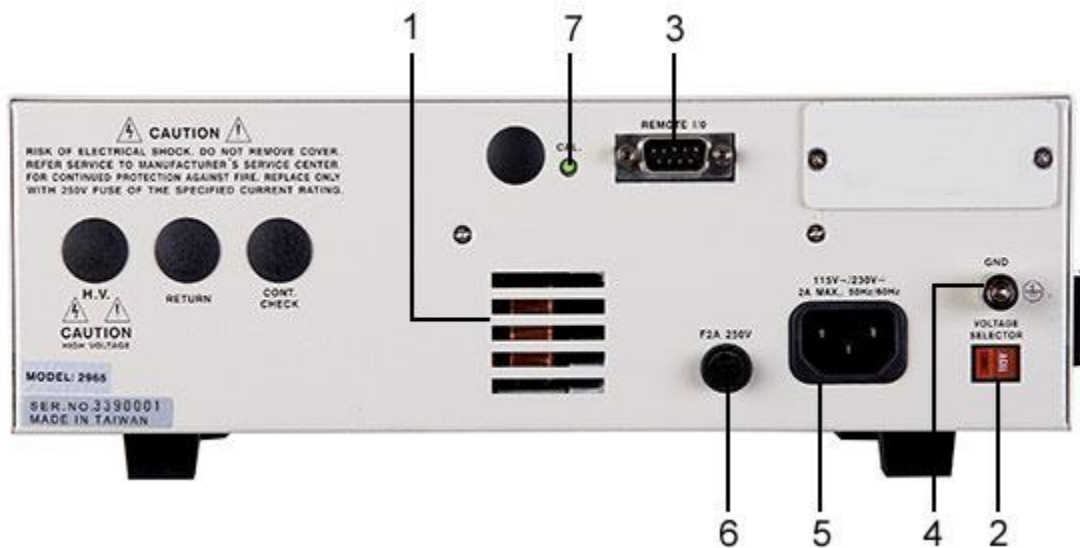

### REAR PANEL CONTROLS

- 1. THERMAL FAN:** To cool the instrument.
- 2. INPUT POWER SWITCH:** Line voltage selection is set by the position of the switch. In the down position, it is set for 115-volt operation, in the up position it is set for 230-volt operation.
- 3. REMOTE INPUT/OUTPUT:** 9-pin D subminiature male connector for remote control of test and reset function as well as for monitoring PASS, FAIL, and PROCESSING output relay signals.
- 4. CHASSIS GROUND (EARTH) TERMINAL:** This safety terminal should be connected to a good earth ground before operation.
- 5. INPUT POWER RECEPTACLE:** Standard IEC 320 connector for connection to a standard NEMA style line power (mains) cord.
- 6. FUSE RECEPTACLE:** To change the fuse unplug the power (mains) cord and turn the fuse cap counter clockwise to remove the fuse.

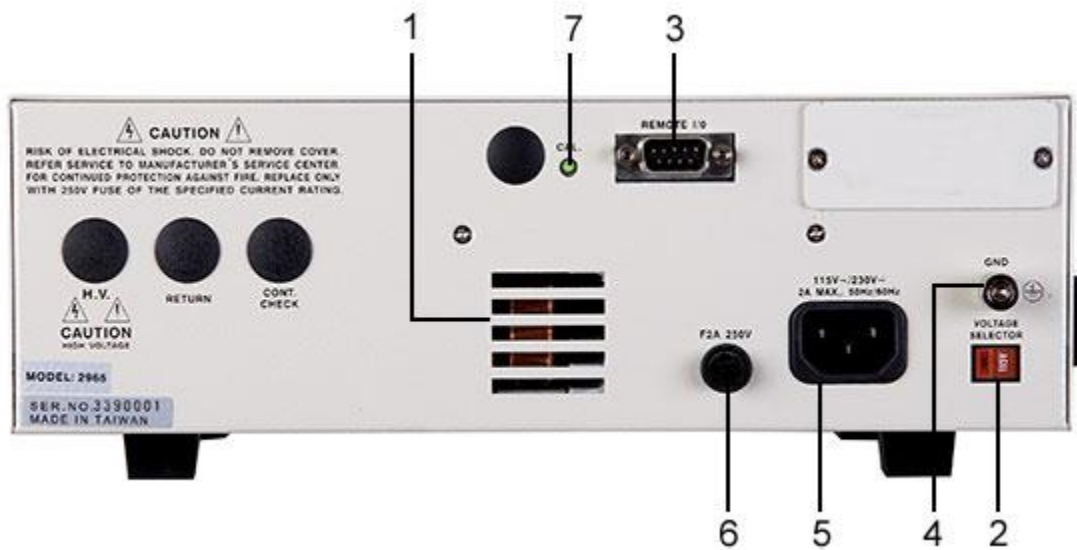

**REAR PANEL CONTROLS**

- 7. CALIBRATION ENABLE KEY:** To enter the calibration mode press this key while the instrument is being powered ON.

## INSTALLATION

### Introduction

This section contains information for the unpacking, inspection, preparation for use and storage of your Slaughter Company, Inc., product.

### Unpacking and Inspection

Your instrument was shipped in a custom foam insulated container that complies with ASTM D4169-92a Assurance Level II Distribution Cycle 13 Performance Test Sequence.

If the shipping carton is damaged, inspect the contents for visible damage such as dents, scratches, or broken meters. If the instrument is damaged, notify the carrier and the Slaughter Company customer support department immediately. Please save the shipping carton and packing material for the carriers inspection. Our customer support department will assist you in the repair or replacement of your instrument. Please do not return your product without first notifying us and receiving an RMA (return materials authorization) number.

### Contents of the Carton

Inside the carton should be the following:

Description	SLA Part Number
2900 Series Instrument	29XX
High Voltage Cable	102-055-913
Return Cable	102-069-904 (Qty. 2)
Fuse	99-10097-01, 3.15 Amp, fast acting 250VAC
Interlock Connector	99-10040-01
Line Cord*	125-013-001 Standard

\*The Line Cord listed is American. Other combinations of the Line Cord are available upon request.

### Preparation for Use

#### Power Requirements and Line Voltage Selection

**CAUTION**

This instrument requires a power source of either 115 volts AC  $\pm$  10%, 47-63 Hz single phase or 230 volts AC  $\pm$ 10%, 47-63 Hz single phase. Please check the rear panel to be sure the proper switch setting is selected for your line voltage requirements before turning your instrument on. In addition, please be sure the correct fuse is selected and installed while the instrument is in the off position.

Do not switch the line voltage selector switch located on the rear panel while the instrument is on or operating. This may cause internal damage and represents a safety risk to the operator.

**NOTE**

For operation at 115 Volts AC and 230 Volts AC use a 2A fast acting fuse.

## Power Cable

**WARNING** BEFORE CONNECTING POWER TO THIS INSTRUMENT, THE PROTECTIVE GROUND (EARTH) TERMINALS OF THIS INSTRUMENT MUST BE CONNECTED TO THE PROTECTIVE CONDUCTOR OF THE LINE (MAINS) POWER CORD. THE MAIN PLUG SHALL ONLY BE INSERTED IN A SOCKET OUTLET (RECEPTACLE) PROVIDED WITH A PROTECTIVE GROUND (EARTH) CONTACT. THIS PROTECTIVE GROUND (EARTH) MUST NOT BE DEFEATED BY THE USE OF AN EXTENSION CORD (POWER CABLE) WITHOUT A PROTECTIVE CONDUCTOR (GROUNDING).

This instrument is shipped with a three-wire power cable. When this cable is connected to an appropriate AC power source, this cable connects the chassis to earth ground. The type of power cable shipped with each instruments depends on the country of destination.

## Operating Environment

This equipment is intended for indoor use only. The equipment has been evaluated according to Installation Category II and Pollution Degree 2 as specified in IEC 664.

This instrument may be operated within the following environmental conditions:

Temperature.....32° - 104° F (0° - 40° C)  
Relative humidity .....0 - 80%  
Altitude .....6,560 feet (2,000 meters)

## STORAGE AND SHIPMENT

### Environment

This instrument may be stored or shipped in environments with the following limits:

Temperature.....-40° - 167° F (-40° - 75°C)  
Altitude..... 50,000 feet (15,240 meters)

The instrument should also be protected against temperature extremes which may cause condensation within the instrument.

## Packaging

Original Packaging: Please retain all original packaging materials if you do not have an alternate method of repackaging. If you are returning your instrument to us for servicing please repackage the instrument in its original container or use an alternate packaging solution. Please do not reuse the original packing material if there appears to be damage or missing packing material. Contact our customer support department (1-800-504-0055) for an RMA (return materials authorization) number. Please enclose the instrument with all options, accessories, and test leads. Indicate the nature of the problem or type of service needed. Also, please mark the container "FRAGILE" to insure proper handling.

Other Packaging: If you do not have the original packaging materials please follow these guidelines:

- 1). Wrap the instrument in a bubble pack or similar foam. Enclose the same information as above.
- 2). Use a strong double-wall container that is made for shipping instrumentation. 350 lb. test material is adequate.
- 3). Use a layer of shock-absorbing material 70 to 100 mm (3 to 4 inch) thick around all sides of the instrument. Protect the control panel with cardboard.
- 4). Seal the container securely.
- 5). Mark the container "FRAGILE" to insure proper handling.
- 6). Please ship models 2955, 2965, and 2975 via Federal Express or UPS air.
- 7). Please refer in all correspondence to your RMA number.

### **Field Installation Of Options**

There are no field installable options on the model 2955, 2965, or 2975.

## QUICK START

This quick start guide assumes the operator has some familiarity with automated hipot testing and desires to use the "**default**" settings on the instrument. The default settings shown will remain in memory unless you choose to override them with your own test program. The default settings will appear in memories 1 through 5 for models 2955, 2965, and 2975. The instrument default settings are as follows:

### DEFAULTS

- **Input Voltage:** 115 or 230 volts AC country specific  
(rear panel switch selectable)
- **Lock:** OFF
- **Test:** W - I (2975)

### Dielectric Withstand Test Mode

- **Voltage Output:** 1,240 volts AC
- **High Current Trip:** HI-LMT: 10 mA
- **Low Current Trip:** LO-LMT: 0 mA (2955, 2965, 2975)
- **Ramp Timer:** 0 second (2955, 2965, 2975)
- **Dwell Timer:** 1 second
- **Voltage Type:** AC
- **AC Output Frequency:** 60Hz
- **Continuity:** OFF

### Insulation Resistance Mode (model 2975)

- **Voltage Output:** 1,000 volts DC
- **High Resistance Trip:** I - High: 0 M $\Omega$
- **Low Resistance Trip:** I - Low: 1 M $\Omega$
- **Delay Timer:** 2 seconds



a). Unpack this instrument from its special shipping container. Be sure to save all packaging materials in case you need to return it to the factory for service.

**WARNING** b). Locate a suitable testing area and be sure you have read all safety instructions for the operation of the instrument and suggestions on the test area set-up in the SAFETY section of this manual. Locate a three prong grounded outlet. Be sure the outlet has been tested for proper wiring before connecting the instrument to it.

**CAUTION** c). Check to be sure the correct input line voltage has been selected on the rear panel. Either 115 volts AC or 230 volts AC. Connect the power input plug into its socket on the rear panel of the instrument. Connect the male end of the plug to the outlet receptacle.

Please be sure that the safety ground on the power line cord is not defeated and that you are connecting to a grounded power source.

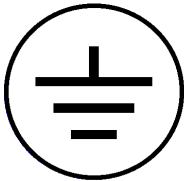

d). Turn on the POWER switch located on the lower left hand side of the front panel. Upon powering the instrument up a POWER ON SELF TEST (POST) will automatically be performed. This test will check for the condition of the ram chips, led indicators, pcb's and other critical components. All of the front panel led's will light temporarily then go out. In addition, you will see the Slaughter Company name and Model Number briefly appear on the LCD readout and then clear itself.

SLAUGHTER		
2975	VER	█

Current software version displayed here

SET	1.0S
1.24KVAC	10.00mA

You should then see the default parameters on the LCD meter as follows for models :

SET	M1	1.0S
1.24KVAC	10.00mA	

Or these defaults for models 2955 and 2965:

W - SET	M1_	1.0S
1.24KVAC	10.00mA	

Or these defaults for models 2975. The underbar character after the memory location indicates that an Insulation Resistance test will execute after the Dielectric Withstand test is completed successfully.

These abbreviated parameters stand for the following:

- SET:** This is the parameter settings review screen.  
**W - SET:** This is the parameter settings review screen for Dielectric Withstand test mode.  
**M1:** Indicates the memory location of the current settings.  
**M1\_:** Indicates that an Insulation Resistance test will execute after the Dielectric Withstand test is completed successfully. (2975)  
**1.0 S:** The dwell timer is set to a test duration of 1 second.  
**1.24KVAC:** The test voltage is set to 1,240 volts AC.  
**10.00 mA:** The high leakage current trip point is set to 10 milliamps.

If you wish to not use any one of these parameters you must change your parameters. Please refer to the Operation Instructions section in this manual for further details.

e). If the instrument defaults are acceptable then be sure to connect the appropriate test leads to the device under test (DUT) or test fixture. Be sure to connect this safety ground to a suitable known good ground before energizing this instrument and then connect the return lead first (black) to the test fixture or item followed by the high voltage output lead (red).

**WARNING** f). Please check your connections to be sure they are making good contact and that the test station or area is clear of debris and other personnel. **DO NOT TOUCH THE DEVICE UNDER TEST ONCE THE TEST HAS BEEN STARTED.** To initiate the test press the GREEN test button on the front panel. This is a momentary button and does not need to be held in the pressed position during the test. The instrument will then cycle ON and begin the automated test sequence using the defaults. If a failure occurs, you will HEAR an audible alarm go off. To stop the alarm you must depress the RED button marked RESET. This will silence the alarm and reset the instrument to begin another test. This RESET button may also be used as a safety button to quickly ABORT a test and cut off the HIGH VOLTAGE.



When HIGH VOLTAGE is present, a RED flashing indicator located above the HV receptacle will remain flashing until the HIGH VOLTAGE is OFF. If the device under test PASSED the test then no audible alarm will sound. You will hear a brief BEEP to let you know the item was successfully tested and it PASSED. In the case of a FAIL condition, the instrument will provide a memory of the test condition results on the LCD display that will remain until the next test is initiated. Depressing the reset button will reset the instrument alarm while keeping the last test results on the display. Depressing the reset button a second time will clear the display.

## OPERATION INSTRUCTIONS FOR Models 2955, 2965, and 2975

### A. POWER UP:

**CAUTION**

Check to be sure the correct input line voltage has been selected on the rear panel. Either 115 volts AC or 230 volts AC. Connect the power input plug into its socket on the rear panel of the instrument. Connect the male end of the plug to the outlet receptacle.

Please be sure that the safety ground on the power line cord is not defeated and that you are connecting to a grounded power source. Also, connect the rear panel chassis ground for additional safety.

Turn on the POWER switch located on the lower left hand side of the front panel. Upon powering the instrument up, a POWER ON SELF TEST (POST) will be automatically performed. This test will check for the condition of the ram chips, pcb's and other critical components. In addition the display will show the following message, with the actual model number displayed in place of *model #* below.

```
SLAUGHTER  
model #      V E R : X . X
```

The instrument will recall the last setup which was active and the display will show the parameters which were programmed into the unit. The instrument is now ready for operation.

### B. SETUP PROCEDURE:

#### 1. To select the Memory location on models 2955, 2965, and 2975

Please press the SET key until the display shows

```
M e m o r y   =   X
```

Use the Up/Down arrow keys to select memory locations 1 through 5. After selecting the memory, press the SET key to view the settings that have been recalled from memory or to make any changes to these settings.

To store any changes to the settings press the Exit key. The parameters are automatically updated into the memory location that was selected, when exiting to the test mode.

## 2. To set the test type and sequence for model 2975

On model 2975 only the Insulation Resistance (I) and Dielectric Withstand (W) test can be run independently or as a sequence of tests. When “W” or “I” is selected, the instrument executes only the test selected. When “W-I” is selected, first the Dielectric Withstand test will execute and then the Insulation Resistance test will execute, selecting “I-W” executes the two tests in the reverse order. To change the Test type on model 2975 only, please press the SET key until the display shows:

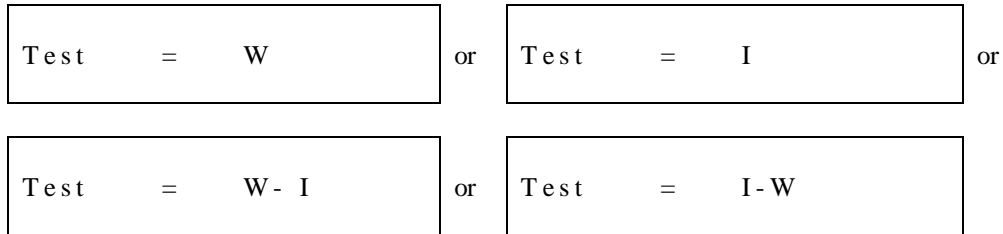

Press the Up or Down Arrow keys to toggle the test selection; then press the EXIT key to exit to the test mode or toggle to another setting using the SET key.

Note: The Test mode type will affect the number of items displayed in the menu. The menu will display only the items that are relative to the Test mode that has been selected.

## 3. To set the AC / DC mode for models 2965 and 2975

Press the SET key until the display shows:

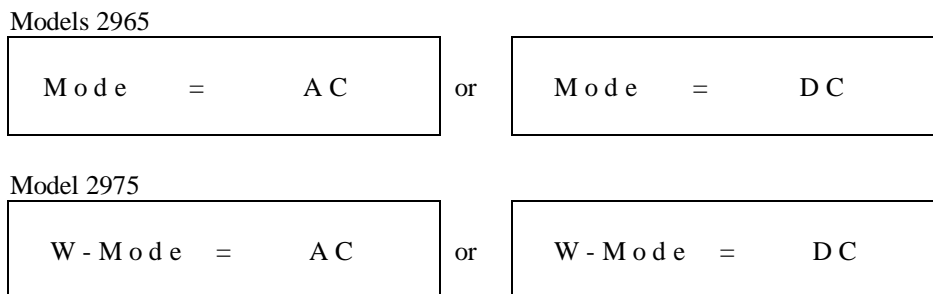

Press the Up or Down Arrow keys to toggle the output function; AC or DC, then press the EXIT key to exit to the test mode or toggle to another setting using the SET key.

## 4. To set the Output Test Voltage

Please press the SET key until the display shows:

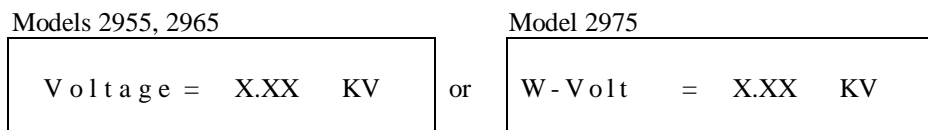

Please use the Up/Down Arrow keys to enter the desired test voltage, then press the EXIT key to exit to the test mode or toggle to another setting using the SET key. The maximum voltage which may be entered is 5000 volts AC or 6000 volts DC.

### 5. To set the High Leakage Current Limit

Please press the SET key until the display shows:

Models 2955, and 2965

HI - L M T = XX.XX mA

or

Model 2975

W - H i g h = XX.XX mA

Use the Up/Down Arrow keys to enter the leakage current high limit setting, then press the EXIT key to exit to the test mode or toggle to another setting using the SET key. The unit of measure is in milliamperes with 0.10 AC and 0.02 DC milliamperes as the minimum setting.

### 6. To set the Low Leakage Current Limit on models 2955, 2965, and 2975

Please press the SET key until the display shows:

Models 2955, 2965

LO - L M T = XX.XX mA

or

Model 2975

W - L o w = XX.XX mA

Use the Up/Down Arrow keys to enter the leakage current low limit setting, then press the EXIT key to exit to the test mode or toggle to another setting using the SET key. The unit of measure is in milliamperes with 0.00 milliamperes AC and DC as the minimum setting.

### 7. To set the Ramp Time on models 2955, 2965, and 2975

Please press the SET key until the display shows:

Models 2955, 2965

R a m p - T = XXX . X s

or

Model 2975

W - R a m p = XXX . X s

Use the Up/Down Arrow keys to enter the ramp time setting, then press the EXIT key to exit to the test mode or toggle to another setting using the SET key. If the ramp time is set to "0", the instrument will raise the voltage up to the test voltage in a fixed ramp time of 0.1 seconds AC and DC and then begin the dwell cycle. The minimum ramp time setting is 0.2 seconds with 0.1 second resolution.

### 8. To set the Dwell Time

Please press the SET key until the display shows:

Models 2955, and 2965

T i m e r = XXX . X s

or

Model 2975

W - D w e l l = XXX . X s

Use the Up/Down Arrow keys to enter the dwell time setting, then press the EXIT key to exit to the test mode or toggle to another setting using the SET key. If the dwell time is set to “0”, the instrument will operate in a continuous ON mode when the test button is depressed and released. It will stop when the DUT (Device Under Test) goes into failure or the manual reset button is pressed. The minimum dwell time setting is 0.2 seconds with 0.1 second resolution.

### 9. To setup the Ground Continuity Check

Please press the SET key until the display shows:

Models 2955 and 2965

Continuity = ON or Continuity = OFF

Model 2975

W-Continuity = ON or W-Continuity = OFF

Press the Up/Down Arrow key to select the “ON” or “OFF” function of the Ground Continuity Check mode, the display will show the set status immediately.

Press the EXIT key to exit to the test mode or toggle to another setting using the SET key.

If the Continuity Function is set to “ON,” the Ground Continuity cable has to be connected between the “Cont. Check” connector on the instrument panel and the chassis of the DUT. The instrument will test the ground connection of the DUT automatically. If continuity is present, a green indicator will be illuminated on the TEST switch and the operator may proceed with the hipot test. The instrument will continue to test the ground connection of the DUT during other tests. If no continuity is present while the operator tries to initiate a test, the instrument will signal a continuity failure.

### 10. To set the Ground Continuity Check High or Low Limits

Please press the SET key until the display shows:

HI-Limit = XXXΩ or LO-Limit = XXXΩ

Please use the Up (^) or Down (v) arrow keys to enter the desired value of the High or Low Limits resistance trip point then press the EXIT key to store the setting and return to the test mode, or press the SET key to advance to the next parameter. The unit of measure is in ohms with a HI-Limit range of 0.00Ω - 1.50Ω and a low limit range of 0.01-1.50Ω. Any attempt to set the value outside this limits will produce two short beeps as an ERROR message.

### 11. To set the Offset

Please press the SET key until the display shows:

Offset = XXX $\Omega$ TEST to Auto Set
---

Please use the Up ( $\wedge$ ) or Down ( $\vee$ ) arrow keys to adjust the setting of the offset manually, then press the EXIT key to store the setting and return to the test mode, or press the SET key to advance to the next parameter. To set the Offset automatically, press the TEST button when the test leads or test fixture is connected across the instrument Return and Current outputs. The instrument will measure the resistance that is present and enter this value into the Offset setting. This offset will be automatically subtracted from the actual resistance reading before the reading is displayed. The unit of measure is in ohms with a range of 0.00 $\Omega$  - 0.50 $\Omega$ . Any attempt to set the value outside this limits will produce two short beeps as an ERROR message.

### 12. To set the Frequency 50/60 Hz

Please press the SET key until the display show

Models 2955 and 2965

Freq = 50 HZ	or	Freq = 60 HZ
--------------	----	--------------

Model 2975

W-Freq = 50 HZ	or	W-Freq = 60 HZ
----------------	----	----------------

Press the Up or Down Arrow keys to toggle the frequency selection; 50 or 60 hertz, then press the EXIT key to exit to the test mode or toggle to another setting using the SET key.

### 13. To Set Key Lock or Memory Lock

The 2900 family of Hipots is equipped with two different lockout selections. The first selection is Key Lock. Within this selection, you can lockout all front panel control functions except TEST and RESET. The second selection is Memory Lock and is used in conjunction with the Key Lock. Within this selection, you can lockout all front panel control functions except TEST, RESET and memory select.

You can toggle this selection only from a power OFF state. Please turn the POWER switch to the off position then press and hold the SET key, then turn the power ON. Momentarily you will see one of the following screens to indicate if the keys are locked or unlocked:

Key Lock = ON
---------------

Key Lock = OFF
----------------

or

To toggle the Key Lock function on and off use the Up or Down Arrow keys, then press EXIT to select, or press the SET key again to reach the Memory Lock screens.

The memory lock screens appear as follows:

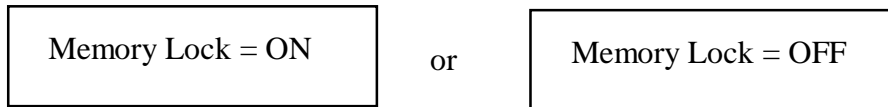

To toggle the Memory Lock function on and off use the Up or Down Arrow keys, then press EXIT to select, or press the SET key again to reach the Key Lock screens.

Use the following chart to set the Key Lock and Memory Lock for your application.

Key Lock	Memory Lock	Accessible keys
Off	Off	All
Off	On	All
On	Off	TEST, RESET, and Up-Down Arrows for memory selection
On	On	TEST and RESET

#### 14. To set the IR output Test Voltage on model 2975

Please press the SET key until the display shows:

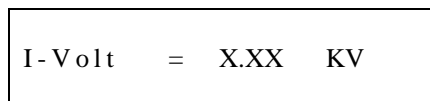

Please use the Up/Down Arrow keys to enter the desired test voltage, then press the EXIT key to exit to the test mode or toggle to another setting using the SET key. The maximum voltage which may be entered is 1.00 kilovolts DC.

#### 15. To set the High Resistance Limit on model 2975

Please press the SET key until the display shows:

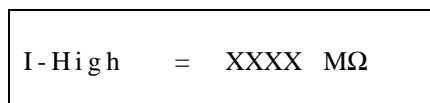

Use the Up/Down Arrow keys to enter the resistance high limit setting, then press the EXIT key to exit to the test mode or toggle to another setting using the SET key. The unit of measure is in megohms with 0 - 1000 MΩ range of setting. A setting of 0 MΩ disables the high limit setting. A measured value above the High Limit setting will result in a failure condition at the end of the Delay time setting.

#### 16. To set the Low Resistance Limit on model 2975



Please press the SET key until the display shows:

I-Low = XXXX MΩ

Use the Up/Down Arrow keys to enter the resistance low limit setting, then press the EXIT key to exit to the test mode or toggle to another setting using the SET key. The unit of measure is in megohms with 1 - 1000 MΩ range of setting. A measured value below the Low Limit setting will result in a failure condition at the end of the Delay time setting.

### 17. To set the Delay Time on model 2975

Please press the SET key until the display shows:

I-Delay = XXX.X s

Use the Up/Down Arrow keys to enter the delay time setting, then press the EXIT key to exit to the test mode or toggle to another setting using the SET key.

If the delay time is set to “0”, the instrument will operate in a continuous ON mode when the test button is pressed and released. The test will stop only when the manual reset button is pressed to abort the Test. The minimum delay time setting is 0.5 seconds with 0.1 second resolution.

Note: The Delay timer in the IR mode differs from the Dwell timer in the Hipot mode. A judgment is not made until the Delay time has elapsed. In the Hipot mode a Pass / Fail judgment is made as soon as the leakage limits are exceeded. Therefore, when the Delay time is set to zero Pass and Fail judgment or indications will not be made.

**C. OPERATING PROCEDURES:**

1. If the instruments defaults are acceptable then be sure to connect the appropriate test leads to the device under test (DUT) or test fixture. Be sure to connect the safety ground (on the rear panel) to a suitable known good ground before energizing this instrument. Then connect the return lead first to the test fixture or the DUT followed by the high voltage lead.

Check your connections to be sure they are making good contact and that the test station or area is clear of debris or other personnel. **DO NOT TOUCH THE DEVICE UNDER TEST ONCE THE TEST HAS BEEN STARTED.**

**WARNING** 2. Please follow the setup procedures to set the parameters. The display will show the Dwell or Delay Timer value, the Test Voltage value, and the High Limit Setting. On model 2955, 2965, and 2975 the memory location will also be displayed.

models 2955 and 2965

<pre> Set      MX    XXX . X s X . XX K V A C    XX . X X mA         </pre>
---

On model 2975 the display will show either the Dielectric Withstand test settings or the Insulation Resistance test settings depending on what has been selected, as follows:

model 2975		
<pre> W - Set    MX    XXX . X s X . XX K V A C    XX . X X mA         </pre>	or	<pre> I - Set    MX    XXX . X s X . XX K V DC    XXX . X MΩ         </pre>

On model 2975 the underbar character may be displayed after the memory number (i.e. M5\_) this indicates that there is another configured test that will execute after the displayed setup has completed successfully. To view the second test setup, press the down arrow key. Return to the first test by pressing the up arrow key. If a second test is not configured an audible beep will be heard when the arrow keys are pressed.

**Dielectric Withstand Test Mode**

3. If you are performing a Ground Continuity Check the Ground Continuity must be set to the “ON (Enabled)” position. The ground check cable has to be connected properly to the chassis of the DUT and the green indicator on the TEST switch should be illuminated before activating the Test switch. Otherwise, the instrument will signal a *continuity failure* when the test switch is activated. Please refer to page 41 for the proper test connections using the adapter box, to test items terminated in a three-prong plug.

The display will show:

models 2955 and 2965

```
CONT .      MX    0.0 s
- . - - K V A C      - . . - - mA
```

model 2975

```
W - CONT    MX    0.0 s
- . - - K V A C      - . . - - mA
```

If you are not performing a Ground Continuity Check, the Ground Continuity must be set to the “OFF” (Disabled) position. It is not necessary to connect the “Cont.Check” cable since this test will not be performed if the circuit is disabled. The instrument will proceed with the Hipot Test when the “Test” switch is activated.

4. To initiate a test, press the TEST switch on the front panel. The red High Voltage Arrow indicator will flash and the display will immediately show:

models 2955 and 2965

```
R a m p      MX    XXX . X s
X . XX K V A C    XX . XX mA
```

or

```
D w e l l    MX    XXX . X s
X . XX K V A C    XX . XX mA
```

model 2975

```
W - R a m p    MX    XXX . X s
X . XX K V A C    XX . XX mA
```

or

```
W - T e s t    MX    XXX . X s
X . XX K V A C    XX . XX mA
```

The instrument will continue to output the desired voltage for the duration of the selected dwell time for model or selected Ramp and Dwell times on model 2955, 2965, and 2975.

5. If there is a short circuit in the DUT during the test, the red indicator light will illuminate on the RESET switch and an alarm will sound. The display will show:

models 2955 and 2965

```
HI - FAIL  MX  XXX . X s  
X . XX K V A C  OFL  mA
```

model 2975

```
W - H i g h  MX  XXX . X s  
X . XX K V A C  OFL  mA
```

6. If a flash over occurs in the DUT during the test, which results in an OFL condition due to the current exceeding the maximum metering range, Breakdown will be indicated as follows. The red indicator light will illuminate on the RESET switch and an alarm will sound. The display will show:

models 2955 and 2965

```
HI - FAIL  MX  XXX . X s  
X . XX K V A C  OFL  mA
```

model 2975

```
W - H i g h  MX  XXX . X s  
X . XX K V A C  OFL  mA
```

7. If the leakage current exceeds the metering range and neither a short circuit nor flash over occurred, the red indicator light will illuminate on the RESET switch and an alarm will sound. The display will show:

models 2955 and 2965

```
HI - FAIL  MX  XXX . X s  
X . XX K V A C  OFL  mA
```

model 2975

```
W - H i g h  MX  XXX . X s  
X . XX K V A C  OFL  mA
```

8. If the leakage current exceeds the high limit setting, but does not exceed the metering range, the red indicator light will illuminate on the RESET switch and an alarm will sound. The display will show:

models 2955 and 2965

HI - F A I L	MX	XXX . X s
X . XX K V A C		XX.XX mA

model 2975

W - H i g h	MX	XXX . X s
X . XX K V A C		XX.XX mA

9. If the leakage current does not exceed the low limit setting on model 2955, 2965, and 2975, the red indicator light will illuminate on the RESET switch and an alarm will sound. The display will show:

models 2955 and 2965

LO - L M T	MX	XXX . X s
X . XX K V A C		XX . XX mA

or

model 2975

W -L o w	MX	XXX . X s
X . XX K V A C		XX . XX mA

10. To stop the alarm, please press the RESET switch once. The alarm will stop and the display will retain the failure information. If the RESET switch is pressed again, the data on the display screen will be cleared and the display will indicate the setting data from the last test. The instrument is now ready for the next test.

11. If the DUT passed the test, the instrument will output a short audible beep tone to indicate the DUT has passed the test. The display will show:

models 2955 and 2965

P a s s	MX	XXX . X s
X . XX K V A C		XX . XXmA

model 2975

W -P a s s	MX	XXX . Xs
X . XX K V A C		XX . XXmA

The instrument is now ready to perform another test.

12. If the operator elects to abort a test in process this can be accomplished by pressing the RESET switch at anytime. The instrument will stop the test process immediately and the display will show:

models 2955 and 2965

A b o r t	MX	XXX . X s
X . XX K V A C		XX . XX mA

model 2975

W - A B R T	MX	XXX . X s
X . XX K V A C		XX . XX mA

Please press the TEST switch to initiate another test.

### Insulation Resistance Test Mode model 2975

13. To initiate a test press the TEST switch on the front panel. The red High Voltage Arrow indicator will flash and the display will immediately show:

I - T e s t	MX	XXX . X s
X . XX K V D C		XXX . X M $\Omega$

14. If the DUT passed the test, the instrument will output a short audible beep tone to indicate the DUT has passed the test. The display will show:

I - P a s s	MX	XXX . X s
X . XX K V D C		XXX . X M $\Omega$

15. If the operator elects to abort a test in process this can be accomplished by pressing the RESET switch at anytime. The instrument will stop the test process immediately and the display will show:

I - A B R T	MX	XXX . X s
X . XX K V D C		XXX . X M $\Omega$

16. If the insulation resistance exceeds the high limit setting, but does not exceed the metering range, the red indicator light will illuminate on the RESET switch and an alarm will sound. The display will show:

I - H i g h	M X	XXX . X s
X . XX K V D C		XXX . X MΩ

17. If the insulation resistance exceeds the high limit setting, and exceeds the metering range, the red indicator light will illuminate on the RESET switch and an alarm will sound. The display will show:

I - H i g h	M X	XXX . X s
X . XX K V D C		> 1 0 0 0 MΩ

18. If the leakage current does not exceed the low limit setting and is within the metering range the red indicator light will illuminate on the RESET switch and an alarm will sound. The display will show:

I - L o w	M X	XXX . X s
X . XX K V D C		XXX . X MΩ

19. If the leakage current does not exceed the low limit setting and is not within the metering range the red indicator light will illuminate on the RESET switch and an alarm will sound. The display will show:

I - L o w	M X	XXX . X s
X . XX K V D C		< 1 MΩ

**D. CONNECTION OF REMOTE I/O:**

A 9-pin “D” type connector is mounted on the rear panel which provides REMOTE-INPUT-OUTPUT control and information. This connector mates with standard 9-pin “D” subminiature connector provided by the user. The Remote I/O mates to a female (receptacle) connector. For best performance, a shielded cable should be used. To avoid ground loops the shield should not be grounded at both ends of the cable. Suggested AMP part numbers for interconnecting to the Remote I/O are shown below.

205203-3	RECEPTACLE SHELL
745253-7	CRIMP SNAP-IN SOCKET CONTACT (for receptacle)
745171-1	SHIELDED CABLE CLAMP (for either plug or receptacle)
747784-3	JACKSCREW SET (2)

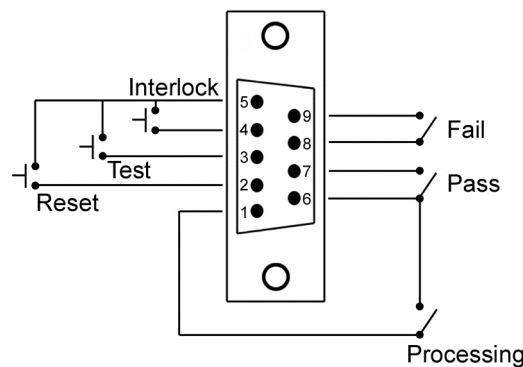
**REMOTE INTERFACE REAR PANEL:****1. SIGNAL OUTPUTS ON REMOTE I/O**

The rear panel connector provides output signals to remotely monitor PASS, FAIL, and PROCESSING conditions. These signals are provided by three normally open internal relays that switch on to indicate the current condition of the tester. These are normally open free contacts and will not provide any voltage or current. The ratings of the contacts are 1A / 250 VAC ( 0.5 ADC ). Below is a listing that indicates what conditions activate each pin. When a terminal becomes active, the relay closes thereby allowing the external voltage to operate an external device.

Pins 6 and 7 provide the PASS signal.

Pins 8 and 9 provide the FAIL signal.

Pins 1 and 6 provide the PROCESSING signal.

The following describes how the relays operate for each test condition.

**PROCESSING** - The relay contact closes the connection between pin (1) and pin (6) while the instrument is performing a test. The connection is opened at the end of the test.



PASS - The relay contact closes the connection between pin (6) and pin (7) after detecting that the item under test passed all tests. The connection is opened when the next test is initiated or the reset function is activated.

FAIL - The relay contact closes the connection between pin (8) and pin (9) after detecting that the item under test failed any test. The connection is opened when the next test is initiated or the reset function activated.

## 2. SIGNAL INPUTS OF REMOTE I/O

The 2900 family of Hipots remote connector enables remote operation of the TEST, RESET and INTERLOCK functions. This interlock must be closed to allow a test to start. The SAFETY INTERLOCK is wired between pins 4 and 5 of the interface connector. For manual operation, the provided 9-pin “D” type connector has a jumper between pins 4 and 5. *This mating connector must be in place for manual operation.* For remote operation, the interlock can be appropriately connected to test station guarding.

The interface allows remote operation of the TEST and RESET functions. A normally open momentary switch across pins 3 and 5 allows remote operation of the TEST function. A normally open momentary switch can also be wired across pins 2 and 5 to allow remote operation of the RESET function. The TEST and RESET switches on the front panel remain active during remote operation. A normally open momentary switch can then be wired across pins 3 and 5 to allow remote operation of the TEST function. A normally open momentary switch can also be wired across pins 2 and 5 which allows for remote operation of the RESET function. For safety, the front panel RESET switch remains active even when a remote reset switch is connected so that high voltage can be shut down from either location.

<b>CAUTION</b>
----------------

DO NOT CONNECT VOLTAGE OR CURRENT TO THE SIGNAL INPUTS, THIS COULD RESULT IN DAMAGE TO THE CONTROL CIRCUITRY.

**E. ADAPTER BOX CONNECTION:**

The adapter box is an optional accessory and is not provided as standard equipment with the 2900 family of Hipots. If you would like to acquire an adapter box for use with your Hipot, please contact The Slaughter Company using the contact information provided in the Safety section of this manual.

The following diagram shows how to connect the adapter box to the Hipot and to the device under test.

**WARNING**

Never connect the adapter box to the hipot while the high voltage outputs are energized.

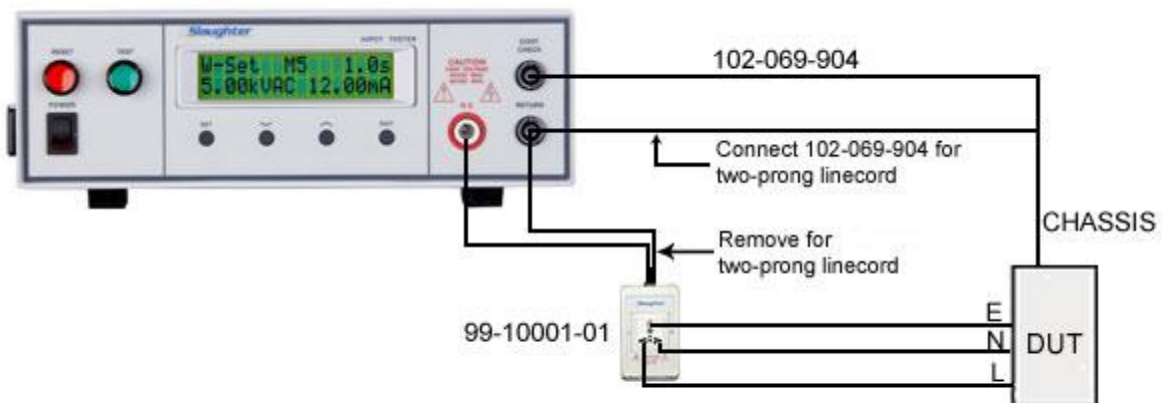

The adapter box allows you an easy way to connect an item which is terminated in a two or three prong line cord. If you are testing a product which is terminated in a three-prong plug, you are also required to perform a continuity or ground bond test on the ground conductor of the DUT to the chassis or dead metal of the product. With the 2900 models, you can perform both the hipot and continuity tests at the same time by activating the continuity function on the instrument.

When the 2955, 2965, or 2975 tests the ground conductor of the line cord, if the resistance of the ground conductor exceeds  $1\Omega$ , the hipot will signal a continuity failure. If continuity is present, high voltage is applied to both conductors of the line cord to insure that all current carrying conductors in the primary circuit are tested.

When you are testing products with two-prong plugs, disconnect the black adapter box lead from the return jack and replace it with the 102-069-904 lead. Do not activate the continuity circuit when testing two-prong DUTs.

## Bus Remote Interface RS-232

This section provides information on the proper use and configuration of bus remote interface. The RS-232 remote interface is optional on the 2955, 2965 and 2975 series models. (Please see Options on page 53 for more information)

### RS-232 Interface

This interface provides all of the control commands and parameter setting commands. All commands can be found in the command list of this manual.

The RS-232 cabling should be configured as follows for a 9-pin serial port interface:

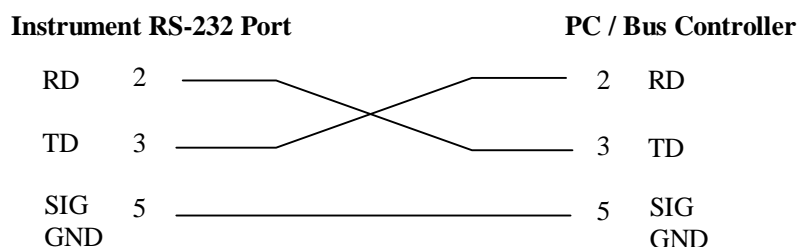

The COM port should have the following configuration. 9600 baud, 8 data bits, 1 stop bit, no parity. This interface does not support XON/XOFF protocol or any hardware handshaking. The controller should be configured to ignore the handshaking lines DTR (pin 4), DSR (pin 6), CTS (pin 8) and RTS (pin 7). If the port cannot be configured through software to ignore the lines then the handshake lines should be jumpered together in two different sets. Pins 4 and 6 jumpered together and pins 7 and 8 jumpered together at the controller end of the cable.

When sending command over the RS232 bus, the instrument will send a response string of 06 hex or 6 decimal, the Acknowledge (ACK) ASCII control code if the transfer was recognized and completed by the instrument. If there is an error with the command string that is sent, the instrument will respond with 15 hex or 21 decimal, the Not Acknowledge (NAK) ASCII control code. The ACK or NAK response allows for software handshaking, to monitor and control data flow. When requesting data from the instrument, it will automatically send the data back to the controller input buffer. The controller input buffer will accumulate data being sent from the instrument including the ACK and NAK response strings, until it has been read by the controller.

### RS-232 Interface Command List

The RS-232 bus will automatically send any response back to the controller's input buffer. Note that the commands are case sensitive and must be typed in capital letters. Each command string should be terminated by the ASCII control code, New Line <NL>, or OAh.

The following conventions are used to describe the commands syntax for the 2900. Braces ( { } ) enclose each parameter for a command string. Triangle brackets ( < > ) indicate that you must substitute a value for the enclosed parameter. The Pipe ( | ) is used to separate

different parameter options for a command. The command and the parameter data must be separated with a space. All commands that end with a question mark (?) are query commands and require an IEEE-488 read command to retrieve the data from the device's output buffer.

### Test Execution Commands

The following commands are used to control actual output voltage and current from the instrument. Please observe all safety precautions.

Command	Description
TEST	Execute a Test
RESET	Abort a Test in Process or Reset Failures
CAO	Continuity Auto Offset

#### TEST

Starts the test sequence at the selected step loaded into memory (RAM).

#### RESET

Stop or abort a test. Also used to reset a latched failure condition.

#### CAO

Set the offset for the Continuity test. The cables and any test fixture should be connected before executing the command. This command will perform an actual test and all safety precautions should be observed when using this command.

### Memory Editing Commands

Command	Description	Value
<b>ML</b> <memory number> <b>ML?</b>	Memory Load	<i>memory number</i> = 1-10
<b>MLP?</b>	List loaded test parameters	
<b>MLP</b> <memory number>?	List specified test parameters	<i>memory number</i> = 1-10
<b>MT</b> <test type> <b>MT?</b>	Set memory test type	<i>test type</i> = 0=W,1=I,2=W-I,3=I-W
<b>MM</b> <test mode> <b>MM?</b>	Set test mode	<i>test mode</i> = 0=AC,1=DC

**ML** <memory number>

Loads the selected memory and sets it as the current test.

**MLP?** / **MLP** <memory number>?

Lists the parameters of the currently loaded test, or the test at the specified memory number.

**MT** <test type>

Sets the test type for the current selected memory

MM <test mode>

Sets whether the withstand test will be AC or DC for the current selected memory.

### Test Parameter Editing Commands and Companion Queries

These commands are used to modify the test parameter within each step. These commands require a parameter value to be included with the command. The values for ACW, DCW and IR tests are sent in kV. The writing of the parameter requires that the unit not be included with the value, only the numeric value should be included with the command. Many of the commands will function the same way for multiple test types; however, the input range may be different and therefore used a different possible set of values.

Command	Name	Test Types	Value
CONN {1 0}	Connect ON/OFF	ALL	1=On, 0=Off
AV <value> AV?	Set Voltage Level	ACW	0.00-5.00kV
DV <value> DV?	Set Voltage Level	DCW	0.00-6.00kV
IV <value> IV?	Set Voltage Level	IR	0.10-1.00kV
AR <value> AR?	Edit Ramp Up	ACW	0.1-999.9sec
DR <value> DR?	Edit Ramp Up	DCW	0.1-999.9sec
AD <value> AD?	Edit Dwell	ACW	0.1-999.9sec
DD <value> DD?	Edit Dwell	DCW	0.1-999.9sec
ID <value> ID?	Edit Delay	IR	0.1-999.9sec
AA <value> AA?	Arc Detect Level	ACW	0-9, 0=Off
DA <value> DA?	Arc Detect Level	DCW	0-9, 0=Off
AH <value> AH?	Edit High Limit	ACW	0.10-12.0mA
AL <value> AL?	Edit Low Limit	ACW	0.00-12.0mA
DH <value> DH?	Edit High Limit	DCW	0.00-5.00mA
DL <value> DL?	Edit Low Limit	DCW	0.00-5.00mA
CH <value> CH?	Continuity High Limit	CONT	0.00-1.50Ω
CL <value> CL?	Continuity Low Limit	CONT	0.00-1.50Ω

IH <value> IH?	Resistance High Limit	IR	0-1000MΩ, 0 = Off
IL <value> IL?	Resistance Low Limit	IR	0-1000MΩ
AF {0 1} AF?	Edit Frequency	ACW	0=50Hz , 1=60Hz
CC {1 0} CC?	Continuity ON/OFF	ACW DCW	1=On, 0=Off
CO <value>	Continuity Offset	CONT	0.00-0.50Ohms

### System Parameter Editing Commands and Companion Queries

These commands are used to modify the system parameters for the instrument. These commands require a parameter value to be included with the command.

Command	Name	Value
SL {1 0} SL?	System Lock	1=On, 0=Off
SML {1 0} SML?	System Memory Lock	1=On, 0=Off

### Query Commands

These query commands will retrieve data from the instrument. These commands include functions for retrieving test data, test results and remote hardware.

Command	Name	Value
TD?	List Testing Data	Data from test in Process
RR?	Read Reset Query	1=Open, 0=Closed
RI?	Read Interlock Query	1=Open, 0=Closed

### TD?

Read the active data being displayed on the LCD display while the test is in process. It will also read the last data taken when the test sequence has completed. Each parameter is separated by commas and includes step number, test type, test status, and metering. The syntax for this command response is {memory - step, test type, status, meter 1, meter 2, meter 3}. ACW test displays 4 meters. Each meter will contain both the value and the units. In the case of DCW current where both uA and mA are used on the display, the command response will always indicate the current in uA for example 2.0mA will respond with 2000uA.

### RR?

Read the remote Reset input signal. When the remote reset has been activated by closing the contacts the query will return a value of 0 to indicate the instrument is being Reset.

**RI?**

Read the remote Interlock input signal. When the remote Interlock has been activated by opening the contacts the query will return a value of 1 to indicate the instrument is in the Interlock state and will not be able to generate output voltage or current.

**IEEE 488.2 Common Commands**

These commands are required by the IEEE-488.2 standard with the exception of \*PSC, \*PSC?. Most of these commands are not available over the RS-232 bus except for the \*IDN? command which can be used to retrieve the instrument identification information, and the four status reporting commands \*ESR?, \*ESE, \*ESE? and \*STB?.

Command	Name	Description
*IDN?	Identification Query	SLA, Model Number, Serial Number, Firmware Revision
*RST	Reset Command	Resets unit
*TST?	Self-Test Query	00H=OK 01H=TEST EEPROM ERROR
*CLS	Clear Status Command	Clear Standard Event Status Register Clear Service Request Register
*OPC	Operation Complete Command	When TEST command ok setting ESR BIT0 =1
*OPC?	Operation Complete Query	1 = TEST completed ok 0 = TEST in process
*WAI	Wait-to-Continue Command	
*PSC {1 0}	Power-on Status Clear Command	1 = Power-on clear enable registers 0 = Power-on load previous enable registers
*PSC?	Power-on Status Clear Query	
*ESR?	Standard Event Status Register Query	0 - 255
*ESE <value>	Standard Event Status Enable Command	value = 0 - 255
*ESE?	Standard Event Status Enable Query	0 - 255
*STB?	Read Status Byte Query	Read Status Byte
*SRE <value>	Service Request Enable Command	value = 0 - 255
*SRE?	Service Request Enable Query	0 - 255

**\*IDN?**

Reads the instrument identification string. Company = Slaughter Company, Inc. Note: Serial Number information is not stored in the instrument's memory; a Serial Number of "0" will be returned in the character string.

**\*RST**

Reset the instrument to original power on configuration. Does not clear Enable register for Standard Summary Status or Standard Event Registers. Does not clear the output queue. Does not clear the power-on-status-clear flag.

**\*TST?**

Performs a self test of the instrument data memory. Returns 0 if it is successful or 1 if the test fails.

**\*CLS**

Clears the Status Byte summary register and event registers. Does not clear the Enable registers.

**\*OPC**

Sets the operation complete bit (bit 0) in the Standard Event register after a command is completed successfully.

**\*OPC?**

Returns an ASCII "1" after the command is executed.

**\*WAI**

After the command is executed, it prevents the instrument from executing any further query or commands until the no-operation-pending flag is TRUE.

**\*PSC {1|0}**

Sets the power-on status clear bit. When set to 1 the Standard Event Enable register and Status Byte Enable registers will be cleared when power is turned ON. 0 setting indicates the Enable registers will be loaded with Enable register masks from non-volatile memory at power ON.

**\*PSC?**

Queries the power-on status clear setting. Returns 0 or 1.

**\*ESR?**

Queries the Standard Event register. Returns the decimal value of the binary-weighted sum of bits.

**\*ESE <value>**

Standard Event enable register controls which bits will be logically ORed together to generate the Event Summary bit 5 (ESB) within the Status Byte.

**\*ESE?**

Queries the Standard Event enable register. Returns the decimal value of the binary-weighted sum of bits.



**\*STB?**

Read the Status Byte. Returns the decimal value of the binary-weighted sum of bits.

**\*SRE <value>**

Service Request enable register controls which bits from the Status Byte should be use to generate a service request when the bit value = 1.

**\*SRE?**

Queries the Service Request enable register. Returns the decimal value of binary-weighted sum of bits.

**Status Reporting**

Status reporting system is configured using two types of registers. An Event Register and a Summary register. The summary register is known as the Status Byte register and records high-level summary information acquired by the event registers.

An Event register report defined conditions or messages at each bit. The bits are latched and remain at an active state until the register is either Read or Cleared. Reading the event register automatically clears the register and sets all bits to inactive state or 0. When querying an event register the information is returned as a decimal number representing the binary-weighted sum of all bits within the register.

The Enable registers bits represent the selection of bits that will be logically-ORed together to form the summary bit in the status byte. The \*CLS command will not clear the enable registers and if you wish to clear the register you must set it to a value of 0. Like the event register, the enable register is represented as a decimal number that equals the binary-weighted sum of all bits.

The enable register will clear to value of 0 at power up unless the \*PSC 0 command had been executed before power-off. The \*PSC command tells the device whether or not it should clear the enable registers at power-on. Using this command will allow SQRs to function immediately after power-on

**Standard Event Register**

Bit	Binary weight	Event Register	Enable Register
0	1	Operation Complete	
1	2	not used	
2	4	Query Error	
3	8	Device Error	
4	16	Execution Error	
5	32	Command Error	
6	64	not used	
7	128	Power On	

\*ESR?

 \*ESE  
 \*ESE?

**Status Byte Register**

Summary Register	Enable Register
ALL PASS	
FAIL	
ABORT	
TEST IN PROCESS	
Message Available (MAV)	
Event Summary Bit (ESB)	
Request Service (RQS) or Master Summary Status (MSS)	not used
PROMPT	

\*STB? | SPOLL

 \*SRE  
 \*SRE?

## MODEL 2955, 2965, and 2975 OPTIONS

### Introduction

This section contains a list and descriptions of available factory installed options at the time of this printing.

### 2955, 2965, and 2975 Options

#### Option List

Code	Description
01	Rear Outputs
02	RS-232 Interface

**OPTIONAL REAR PANEL CONTROLS****Description****01 Rear Outputs**

The Rear Outputs option gives the user the capability to access the High Voltage and Return in addition to the existing Continuity output from the rear panel for use in automated systems. The configuration and descriptions are as follows.

- 1. HIGH VOLTAGE OUTPUT JACK:** For the connection of the detachable 5-foot (1.52 m) red high voltage test lead. The silicone rubber insulation is flexible for easy handling and is rated at 30KVDC. The jack is recessed for safety when this lead is not being used.
- 2. RETURN OUTPUT JACK:** For the connection of the detachable 5 foot (1.52 m) black return test lead or three-prong receptacle adapter box. This jack is always used when performing a test. Please refer section E. Adapter Box connection for details on connecting the adapter box between the instrument and the device under test.
- 3. CONTINUITY CHECK OUTPUT JACK:** For the connection of the detachable 5-foot (1.52 m) return test lead. This jack is always used when performing a continuity test. Please refer section E. Adapter Box connection for details on connecting the adapter box between the instrument and the device under test.

**02 RS-232 Interface**

- 4. RS-232 Interface Port:** This option may be added as a serial type communication protocol. This option provides all of the function control of the RS-232 interface. The

9-pin D-type subminiature connector labeled “RS-232” is for connection of the unit to any compatible PC. When selecting RS232, the protocol for interfacing and communicating with a PC can be found on page 45: Bus Remote Interface RS232 of this manual.

**SECTION 2**  
**SERVICE MANUAL**

## CALIBRATION PROCEDURES

This instrument has been fully calibrated at the factory in accordance to our published specifications. It has been calibrated with standards traceable to NIST. You will find in this manual a copy of the "Certificate of Calibration". It is recommended that you have this instrument recalibrated and a safety check done at least once per year. Slaughter recommends you use "Calibration Standards" that are NIST traceable, or traceable to agencies recognized by NIST to keep this instrument within published specifications. End user metrology standards or practices may vary. These metrology standards determine the measurement uncertainty ratio of the calibration standards being used.

### Calibration Equipment Required:

The following equipment will be needed to properly calibrate your instrument.

- 1). Digital Multimeter with the minimum ranges;
  - AC Voltage: 5,000 volts
  - AC Current: 20mA range.
  - DC Voltage: 6,000 volts
  - DC Current: 5000uA range
  
- 2). 500k $\Omega$ /75Watt resistor/6kV DC
  - 100k $\Omega$ /0.25Watt resistor/300VDC
  - 1M $\Omega$ /0.25Watt resistor/300VDC
  - 50M $\Omega$ /0.25Watt resistor/1000VDC
  - 1 $\Omega$ /0.125Watt resistor/10VDC

### CALIBRATION PROCEDURE:

#### Model 2955 and 2965

To enter the calibration mode the instrument must be in the OFF position. Using a pen or small screwdriver, press and hold the recessed calibration key on the rear panel, then turn on the Input Power Switch.

For model 2955 and 2965 the display will show:

CAL Mode
SET: V    v : A

Press the SET key for kilovolts calibration, Down Arrow key (v) for milliamps.

For model 2975 the display will show:

CAL Mode EXIT:IR SET:V    √:A
----------------------------------

Press the SET key for kilovolts calibration, Down Arrow key (√) for milliamps, and the EXIT key for insulation resistance calibration.



## 1. Calibration of Voltage

Equipment needed: STANDARD AC VOLTMETER capable of measuring 5000VAC.

Please connect a standard ac voltmeter with 5000V minimum full scale range to the high voltage and return connectors.

Then press the SET key on the front panel. The instrument will provide around 5000VAC on the output connectors and the display will show:

V o l t a g e = \_ \_                      V

Please use the Up/Down Arrow keys to enter the reading off the AC Voltmeter into the instrument. Then press the SET key to store the voltage setting. Press the EXIT or RESET key to return to the calibration menu without changing the calibration setting.

The instrument will output two short “beeps” when attempting to save a missing or bad parameter and will not allow return to the calibration menu.

Equipment needed: STANDARD DC VOLTMETER capable of measuring 6000VAC.

Please connect a standard ac voltmeter with 6000V minimum full scale range to the high voltage and return connectors.

Then press the SET key on the front panel. The instrument will provide around 6000VDC on the output connectors and the display will show:

V o l t a g e = \_ \_                      V

Please use the Up/Down Arrow keys to enter the reading off the DC Voltmeter into the instrument. Then press the SET key to store the voltage setting. Press the EXIT or RESET key to return to the calibration menu without changing the calibration setting.

The instrument will output two short “beeps” when attempting to save a missing or bad parameter and will not allow return to the calibration menu.

## 2. Calibration of Dielectric Withstand Current

Equipment needed: STANDARD AC MILLIAMMETER with a range of 25mA and a fixed Resistor 500K Ohms, 75 watts.

Please connect a 500K $\Omega$  resistor in series with the standard ac milliammeter and connect these across the output leads of the instrument. Press the Down Arrow key. The instrument will provide around 5000VAC on the output and the display will show:

C u r r e n t = \_ \_                      mA

Please use the Up/Down Arrow keys to enter the reading of the standard AC milliammeter into the instrument. Then press the SET key to store the current setting. Press the EXIT or RESET key to return to the calibration menu without changing the calibration setting.

The instrument will output two short “beeps” when attempting to save a missing or bad parameter and will not allow return to the calibration menu.

Equipment needed: STANDARD DC MILLIAMMETER with a range of 5mA and a fixed Resistor 500K Ohms, 75 watts.

Please connect a 500K $\Omega$  resistor in series with the standard ac milliammeter and connect these across the output leads of the instrument. Press the Down Arrow key. The instrument will provide around 6000VAC on the output and the display will show:

C u r r e n t = \_ \_      m A

Please use the Up/Down Arrow keys to enter the reading of the standard DC milliammeter into the instrument. Then press the SET key to store the current setting. Press the EXIT or RESET key to return to the calibration menu without changing the calibration setting.

The instrument will output two short “beeps” when attempting to save a missing or bad parameter and will not allow return to the calibration menu.

### 3. Calibration of Insulation Resistance Current model 2975

Equipment needed: STANDARD DC MILLIAMMETER with a range of 5000uA and a fixed Resistor 500K Ohm, 75 watts.

Please connect a 500K $\Omega$  resistor in series with the standard DC microammeter and connect these across the output leads of the instrument. Press the EXIT key. The instrument will provide around 500VDC on the output and the display will show:

C u r r e n t = \_ \_      uA

Please use the Up/Down Arrow keys to enter the reading of the standard DC microammeter into the instrument. Then press the SET key to store the current setting. Press the EXIT or RESET key to return to the calibration menu without changing the calibration setting.

The instrument will output two short “beeps” when attempting to save a missing or bad parameter and will not allow return to the calibration menu.

### 4. Save Calibration

After the calibration, the instrument has to be turned off to save the calibration parameters. The power must be turned off and on again to switch from the calibration mode to the run mode.

## Replacement Parts List

Model 2955, 2965, and 2975

Rev. D ECO 5590 – 10/19/2012

Part Number	Qty.	Reference Designator	Description
99-10553-01 <sup>2</sup>	1	HV7162	High Voltage Control Board
99-10574-01 <sup>1</sup>	1	HV7162	High Voltage Control Board
99-10222-01	1	CKB-06	Key Board Assembly
99-10551-01	1	-	Amplifier Board
99-10552-01	1	CW7120	Main Control Board
99-10572-01	1	RS232-M1	RS232 Interface Board
99-10573-01	1	-	RS232 Cable
99-10016-01	1	-	Earth Connector
99-10017-01	4	-	Black Banana Jacks
99-10018-01	2	-	High Voltage Connector
175-946-013	1	-	Feet Kit w/o Rubber Inserts
175-974-002	4	-	Rubber Insert
99-10097-01	1	-	Fuse 2A, 250V, Fast Acting, 5x20mm
99-10040-01	1	-	Interlock Connector
150-135-003	1	-	Fuse Holder 20mm
99-10355-01	1	-	LCD Display 16 x 2 Characters
99-10312-01	1	-	Power Switch 2P 15A
330-113-001	1	-	Test Switch, Green
330-113-002	1	-	Reset Switch, Red
99-10569-01	1	T2	Output High Voltage Transformer
99-10568-01	1	T1	Input Transformer
125-013-001	1	-	Input Power Cable 10A/6Ft.
102-055-913	1	-	High Voltage Output cable
102-069-904	2	-	Return cable
330-113-001	1	-	Test Switch
330-113-002	1	-	Reset Switch
99-10046-01	1	-	HV LED Red
99-10589-01	3	-	Rear Output Cover Plug Holes
99-10593-01	1	-	Programming Port Cover
99-10224-01	4	-	Button Keypad Plastic Grey
99-10312-01	1	-	RS232 Blanking Cover
99-10555-01	1	-	Blank Cover
175-946-013	1	-	Kit Hipot Feet
175-974-002	4	-	Hipot Feet Rubber Inserts
99-10028-01	3	Q1-Q3	Power Transistors
99-10029-01	1	RY2	Relay Gunther 3392-1290-246
99-10581-01	1	IC22	IC Microcontroller SM5964A
99-10304-01	1	IC36	IC Microcontroller SM8951A
99-10345-01	1	IC38	IC 29C020 EEPROM PLCC



REPLACEMENT PARTS LIST

---

99-10033-01	1	RY1	Relay Gunther 3390-1290-246
99-10671-01	1	Test/Pass	Replacement Bulb
99-10672-01	1	Reset/Fail	Replacement Bulb

<sup>1</sup>2955 Only

<sup>2</sup>2965, 2975 Only

**SCHEMATIC INDEX**

<b>Drawing Number</b>	<b>Description</b>	<b>Pages</b>
S02975	Wiring Diagram	1
S99-10552	Main Control Board	5
S99-10551	Amplifier Board	2
S99-10553	HV Control Board AC/DC	2
S99-10222	Keypad Board	1
S99-10572	RS-232 Board	1