

HP 8481A
HP 8482A
HP 8483A
POWER SENSOR

SERIAL NUMBERS

This manual applies directly to instruments with serial numbers prefixed:

HP 8481A: 2702A

HP 8482A: 2652A

HP 8483A: 2701A

With the changes described in the Appendix, this manual also applies to instruments with serial numbers prefixed:

HP 8481A: 1550A, 1926A, 2237A, 2349A, 2552A

HP 8482A: 1551A, 1925A, 2237A, 2349A, 2607A

HP 8483A: 1602A, 1925A, 2243A, 2329A, 2351A, 2405A, 2623A

For additional important information about serial numbers, see "Instruments Covered By Manual".



© Copyright HEWLETT-PACKARD COMPANY 1975, 1979, 1986, 1990

MANUAL PART NO. 08481-90049

CONTROLLED
DOCUMENT

NOTICE

The information contained in this document is subject to change without notice.

HEWLETT-PACKARD MAKES NO WARRANTY OF ANY KIND WITH REGARD TO THIS MANUAL, INCLUDING, BUT NOT LIMITED TO, THE IMPLIED WARRANTIES OF MERCHANTABILITY AND FITNESS FOR A PARTICULAR PURPOSE. Hewlett-Packard shall not be liable for errors contained herein or direct, indirect, special, incidental or consequential damages in connection with the furnishing, performance, or use of this material.

WARRANTY

A copy of the specific warranty terms applicable to your Hewlett-Packard product and replacement parts can be obtained from your local Sales and Service Office.

Herstellerbescheinigung

Hiermit wird bescheinigt, daß dieses Gerät/System in Übereinstimmung mit den Bestimmungen von Postverfügung 1046/84 funkentstört ist.

Der Deutschen Bundespost wurde das Inverkehrbringen dieses Gerätes/System angezeigt und die Berechtigung zur Überprüfung der Serie auf Einhaltung der Bestimmungen eingeräumt.

Zusatzinformation für Meß- und Testgeräte:

Werden Meß- und Testgeräte mit ungeschirmten Kabeln und/oder in offenen Meßaufbauten verwendet so ist vom Betreiber sicherzustellen, daß die Funkentstörbedingungen unter Betriebsbedingungen an seiner Grundstücksgrenze eingehalten werden.

Manufacturer's Declaration

This is to certify that this equipment is in accordance with the Radio Interference Requirements of Directive FTZ 1046/1984. The German Bundespost was notified that this equipment was put into circulation, and has been granted the right to check the equipment type for compliance with these requirements.

Note: If test and measurement equipment is operated with unshielded cables and/or used for measurements in open setups, the user must ensure that under these operating conditions, the radio frequency interference limits are met at the border of his premises.

General Information

This Operating and Service Manual contains information about initial inspection, performance tests, adjustments, operation, troubleshooting and repair of the HP 8481A, 8482A, and 8483A Power Sensors.

On the title page of this manual is a "Microfiche" part number. This number can be used to order a 4 x 6-inch microfilm transparency of the manual.

Instruments Covered by Manual

This instrument has a two-part serial number. The first four digits and the letter comprise the serial number prefix. The last five digits form a sequential suffix which is unique to each instrument. The contents of this manual apply directly to instruments having the serial number prefix listed under "Serial Numbers" on the title page.

An instrument manufactured after the printing of this manual may have a serial prefix that is not listed on the title page. This unlisted serial prefix indicates that the manual for this instrument is supplied with a yellow Manual Changes supplement that documents the differences.

In addition to change information, the supplement may contain information for correcting errors in the manual. The supplement is keyed to the manual print date and part number, both of which appear on the title page.

For information concerning a serial number prefix not listed on the title page or in the Manual Changes supplement, contact your nearest Hewlett-Packard office.

Description

The Power Sensors are used for measuring the average power supplied by an RF source. In use, the Power Sensor is connected to the RF source and to a compatible power meter. (Suitable meters are the HP 435B, 436A, 437B or 438A Power Meter.) The HP 8481A and 8482A Power Sensors place a 50 Ω load on the RF source (HP 8483A has a 75 Ω load). The power meter indicates the power dissipated in this load in μ W (or mW) and dBm. The HP 436A Power Meter can also provide readings, in dB, relative to a previous RF input to the Power Sensor.

The Power Sensors measure power levels from -30 dBm to +20 dBm (1 μ W to 100 mW), at frequencies from 10 MHz to 18 GHz (HP 8481A), or 100 kHz to 4.2 GHz (HP 8482A), or 100 kHz to 2 GHz (HP 8483A).

The physical configuration of all sensors is the same. However, because of the different frequency ranges covered, there are some changes in part numbers and component values.

CAL FACTOR data is provided on a label attached to the Power Sensor's cover. Maximum uncertainties of the CAL FACTOR data are listed in table 1.

Specifications for the Power Sensor are provided in table 2.

**Option 001
(HP 8481A Only)**

A precision 7 mm RF connector (APC-7) is substituted for the type-N connector.

Accessories Supplied

The HP 8483A is supplied with an adapter (HP 1250-0597, shown in figure 1) for joining the Power Sensor's 75 Ω type N connector to the 50 Ω power reference connector on the power meter. This accessory is a mechanical adapter only, not an impedance transformer. Therefore, an impedance mismatch exists that must be taken into consideration when calibrating the power meter and power sensor. The REF CAL FACTOR, on the power sensor label, has been adjusted for the impedance mismatch. This REF CAL FACTOR, when used to calibrate any HP power meter, will allow calibration to 1.000 mW. The CAL FACTOR, from the data on the power sensor label, should be used for any power measurements in a 75 Ω system at 50 MHz.

Caution



Remove mechanical adapter from the Power Sensor before connecting the sensor to a 75 Ω source.

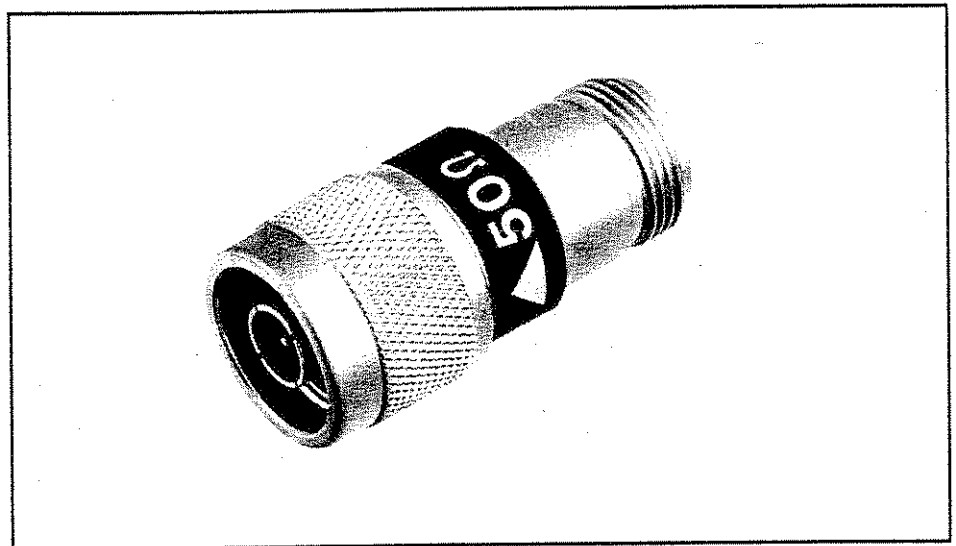

Figure 1. Mechanical Adapter (HP 8483A Only)

**Recommended Test
Equipment**

Table 3 lists the test equipment recommended to check, adjust, and troubleshoot the Power Sensor. If substitute equipment is used, it must meet or exceed the critical specifications.

Table 1. Uncertainty of Calibration Factor Data³

| HP 8481A | | | HP 8482A (cont'd) | | |
|-----------------|--|--|-------------------|--|--|
| Frequency (MHz) | Sum of Uncertainties ±(%) ¹ | Probable Uncertainties ±(%) ² | Frequency (MHz) | Sum of Uncertainties ±(%) ¹ | Probable Uncertainties ±(%) ² |
| 10.0 | 2.5 | 1.3 | 3.0 | 2.2 | 1.2 |
| 30.0 | 2.6 | 1.4 | 10.0 | 2.5 | 1.3 |
| 100.0 | 3.1 | 1.6 | 30.0 | 2.6 | 1.4 |
| 300.0 | 3.1 | 1.6 | 100.0 | 3.1 | 1.6 |
| (GHz) | | | 300.0 | 3.1 | 1.6 |
| 1.0 | 2.7 | 1.4 | 1000.0 | 2.7 | 1.4 |
| 2.0 | 2.7 | 1.4 | 2000.0 | 2.7 | 1.4 |
| 4.0 | 2.8 | 1.5 | 4000.0 | 2.8 | 1.5 |
| 6.0 | 2.8 | 1.5 | HP 8483A | | |
| 8.0 | 3.2 | 1.7 | (MHz) | | |
| 10.0 | 3.6 | 1.9 | 0.1 | 2.6 | 1.5 |
| 12.4 | 4.4 | 2.3 | 0.3 | 2.5 | 1.4 |
| 14.0 | 4.8 | 2.6 | 1.0 | 2.5 | 1.4 |
| 16.0 | 5.2 | 2.9 | 3.0 | 2.5 | 1.4 |
| 18.0 | 5.8 | 3.2 | 10.0 | 3.0 | 1.3 |
| HP 8482A | | | 30.0 | 3.1 | 1.6 |
| (MHz) | | | 100.0 | 3.9 | 2.0 |
| 0.1 | 2.3 | 1.3 | 300.0 | 3.9 | 2.0 |
| 0.3 | 2.2 | 1.2 | 1000.0 | 3.7 | 2.0 |
| 1.0 | 2.2 | 1.2 | 2000.0 | 3.7 | 2.0 |

1 Includes uncertainty of reference standard and transfer uncertainty. Directly traceable to NIST (National Institute of Standards Technology).

2 Square root of the sum of the individual uncertainties squared (RSS).

3 Uncertainties are for sensors with type N connectors. Values will be slightly less for sensors with APC-7 connectors.

Table 2. Specifications

| | |
|---|---|
| HP 8481A | |
| Power Range: -30 dBm to +20 dBm (1 μ W — 100 mW) | |
| Frequency Range: 10 MHz — 18 GHz | |
| Nominal Impedance: 50 Ω | |
| Maximum SWR (Reflection Coefficient): | 10 MHz to 30 MHz <1.4 (0.166) 30 MHz to 50 MHz <1.18 (0.083) 50 MHz to 2 GHz <1.10 (0.048) 2 GHz to 12.4 GHz <1.18 to 0.083) 12.4 GHz to 18 GHz <1.28 (0.123) |
| Maximum Power: 300 mW Average | |
| Maximum Peak Power: 15W Peak | |
| Maximum Energy/Pulse: 30W \cdot μ s | |
| RF Connector: Type N Male | |
| HP 8482A | |
| Power Range: -30 dBm to +20 dBm (1 μ W — 100 mW) | |
| Frequency Range: 100 kHz — 4.2 GHz | |
| Nominal Impedance: 50 Ω | |
| Maximum SWR (Reflection Coefficient): | 100 kHz to 300 kHz <1.60 (0.231) 300 kHz to 1 MHz <1.20 (0.091) 1 MHz to 2 GHz <1.10 (0.048) 2 GHz to 4.2 GHz <1.30 to 0.130) |
| Maximum Power: 300 mW Average | |
| Maximum Peak Power: 15W Peak | |
| Maximum Energy/Pulse: 30W \cdot μ s | |
| RF Connector: Type N Male | |
| HP 8483A | |
| Power Range: -30 dBm to +20 dBm (1 μ W — 100 mW) | |
| Frequency Range: 100 kHz — 2 GHz | |
| Nominal Impedance: 75 Ω | |
| Maximum SWR (Reflection Coefficient): | 100 kHz to 600 kHz <1.80 (0.286) 600 kHz to 2 GHz <1.18 (0.083) |
| Maximum Power: 300 mW Average | |
| Maximum Peak Power: 10W Peak | |
| Maximum Energy/Pulse: 30W \cdot μ s | |
| RF Connector: Type N Male (75 Ω) | |
| Dimensions, Including RF Connector: 30 mm wide, 38 mm high, 105 mm long (1 in. x 1 $\frac{1}{2}$ in. x 5 in.) | |
| Weight: Net, 0.2 kg (8 oz) | |

Note

When operating in the top 10 dB input power range (e.g. +10 to +20 dBm), an error due to deviation from square law operation may occur. This possible error, which applies to the 8481A, 8482A, and 8483A, is expressed as follows:

Worst Case Power Linearity:

+2/-4% (+10 to +20 dBm input range)

Negligible (-30 to +10 dBm input range)

Table 3. Recommended Test Equipment

| Instrument Type | Critical Specifications | Suggested Model | Use ¹ |
|-------------------|--|-------------------|------------------|
| Digital Voltmeter | Range: 100 mVdc to 100 Vdc Input Impedance: 100 m Ω Resolution: 4-digit Accuracy: $\pm 0.05\%$ ± 1 digit | HP 3466A | T |
| Oscilloscope | Bandwidth: dc to 50 MHz Sensitivity: Vertical, 0.2 V/div Horizontal, 1 ms/div | HP 1741A or 1980B | A,T |
| Ohmmeter | Range: 1 — 100,000 Ω Accuracy: $\pm 5\%$ | HP 3466A | T |
| DC Power Supply | Range: 5 to 15 Vdc | HP 6214B | T |

¹ A = Adjustment, T = Troubleshooting

Installation

Initial Inspection

Inspect the shipping container. If the container or packing material is damaged, it should be kept until the contents of the shipment have been checked mechanically and electrically. If there is mechanical damage or if the instrument does not pass the performance tests, notify the nearest Hewlett-Packard office. Keep the damaged shipping materials (if any) for inspection by the carrier and a Hewlett-Packard representative.

Storage and Shipment

Environment

The instrument should be stored in a clean, dry environment. The following limitations apply to both storage and shipment:

Temperature -40 to +75°C

Relative humidity <95%

Altitude < 7,600 metres (25 000 ft)

Original Packaging

Containers and materials identical to those used in factory packaging are available through Hewlett-Packard offices. If the instrument is being returned to Hewlett-Packard for servicing, attach a tag indicating the type of service required, return address, model number, and serial number. Also, mark the container FRAGILE to assure careful handling. In any correspondence, refer to the instrument by model number and serial number.

Interconnections

Refer to the power meter operating and service manual for interconnecting instructions.

Operation

Environment

The operating environment for the Power Sensor should be as follows:

- Temperature 0 to +55°C
- Relative humidity <95%
- Altitude..... < 4,572 metres (15 000 ft)

Operating Precautions

Before the Power Sensor is connected, the following precautions must be observed.

Warning



BEFORE CONNECTING THE POWER SENSOR TO ANOTHER INSTRUMENT, ensure that the instrument and power meter are connected to the protective (earth) ground.

Caution



Exceeding the following energy and power levels may result in damage to the power meter system.

- Maximum Average Power 300 mW
- Maximum Peak Power 15W (10W HP 8483A Only)
- Maximum Energy Per Pulse 30W · μs

Do not apply torque to the Power Sensor's body while connecting or disconnecting the Type N RF connector.

Note



When using the Power Sensor with the HP 435 series Power Meter make sure the correct scale is mounted on the Power Meter RANGE switch. Refer to Section II of the HP 435 series Power Meter Operating and Service Manual.

Operating Procedures

Instructions for use of the Power Sensor are provided in the power meter manual. During operation, the precautions described under "Operating Precautions" must be observed.

SWR (Reflection Coefficient) Performance Test

The maximum SWR and reflection coefficient for each Power Sensor are listed in table 4. For making these measurements, use equipment which has measurement uncertainties not exceeding those shown in the table.

Table 4. SWR and Reflection Coefficient

| Frequency | System SWR Uncertainty | Actual Measurement | Maximum SWR (Reflection Coefficient) |
|--------------------|------------------------|--------------------|--------------------------------------|
| HP 8481A | | | |
| 10 to 30 MHz | ±0.030 | _____ | < 1.40 (0.166) |
| 30 to 50 MHz | ±0.020 | _____ | < 1.18 (0.083) |
| 50 MHz to 2 GHz | ±0.020 | _____ | < 1.10 (0.048) |
| 2 to 12.4 GHz | ±0.020 | _____ | < 1.18 (0.083) |
| 12.4 to 18 GHz | ±0.025 | _____ | < 1.28 (0.123) |
| HP 8482A | | | |
| 100 kHz to 300 kHz | ±0.08 | _____ | < 1.60 (0.231) |
| 300 kHz to 1 MHz | ±0.04 | _____ | < 1.20 (0.091) |
| 1 MHz to 2 GHz | ±0.02 | _____ | < 1.10 (0.048) |
| 2 to 4.2 GHz | ±0.02 | _____ | < 1.30 (0.130) |
| HP 8483A | | | |
| 100 kHz to 600 kHz | ±0.08 | _____ | < 1.80 (0.286) |
| 600 kHz to 2 GHz | ±0.02 | _____ | < 1.18 (0.083) |

FET Balance Adjustment

The FET balance adjustment should be performed if the wires connecting J1 to the A2 printed circuit have been moved. If you have replaced A2 or moved the wires during troubleshooting you will need to perform this adjustment. You do not need to perform a FET balance adjustment after an A1 bulkhead assembly replacement if the wires between J1 and A2 have not been disturbed.

Warning



The following procedure exposes high voltage areas within the power meter. Use extreme care while working around these areas or personal injury could occur.

Equipment

- Oscilloscope HP 54200A
- Power Meter HP 435B
- Multimeter HP 3478A

The sampling gate balance is affected by the relative positions of the wires in the Power Sensor, which connect to pins G and H of connector J1. One wire is black and white; and the other is brown and white. Moving the black and white wire will adjust the switching transient amplitude (spike). Moving the brown and white will change the offset. Once positioned, care must be used not to displace these wires. To correctly position these wires, after replacement of the printed circuit

board or if the wires have been moved so as to affect the sampling gate balance, perform the following procedure:

1. Set the multimeter controls as follows:

| | |
|----------|-------------------|
| FUNCTION | dc Voltage |
| RANGE | 20 mV, full scale |

2. Set oscilloscope controls as follows:

| | |
|-------------|-----------|
| SENSITIVITY | 0.2 V/DIV |
| SWEEP | 1 ms/DIV |
| TRIGGER | INT |
| DISPLAY | A |

3. Set the Power Meter CAL FACTOR to 100%. Set the Power Meter RANGE to 1 mW (0 dBm).
4. Open the Power Sensor (see "Disassembly Procedure", steps 1 through 3). Zero and calibrate the Power Meter. Leave the opened Power Sensor connected to the Power Meter POWER REF output. Heat can affect the adjustments so handle the sensor as little as possible.
5. Turn OFF the POWER REF switch on the rear panel of the Power Meter.
6. Remove the HP 435B bottom panel. This will expose the circuit side of the A5 printed circuit board. On A5 you will see a long double row of soldered terminals numbered 1 to 44.
7. Connect a probe from pin 40 (the number "902" is printed on the board next to pin 40) to the multimeter input.
8. Lay the HP 435B on its left side and remove the right panel. This will expose the A4 assembly.
9. Connect a 1:1 probe from TP4 to channel A on the oscilloscope.
10. **Offset.** Read the multimeter and adjust the position of the brown and white wire until the reading is between -7.0 mV and -2.0 mV. *Helpful hint:* the relative position of the brown and white wire to C4 will adjust the offset.
11. **Switching transients.** Read the oscilloscope and adjust the position of the black and white wire until the switching transients are less than 0.8V peak to peak. *Helpful hint:* the relative position of the black and white wire to the collector of Q1 will adjust the switching transients.

You will find that positioning the wire for switching transients affects the offset. Go back and forth between the two wires, positioning and repositioning, until both adjustments are within specifications.

Replaceable Parts

Table 5 is a list of replaceable parts. Figure 2 illustrates the major parts. To order a part listed in the "Replaceable Parts" table, quote the Hewlett-Packard part number with Check Digit (CD), indicate the quantity required, and address the order to the nearest Hewlett-Packard office.

Note



Within the USA, it is better to order directly from the HP Parts Center. Ask your nearest HP office for additional information. Also, your nearest HP office can supply toll free telephone numbers for ordering parts and supplies.

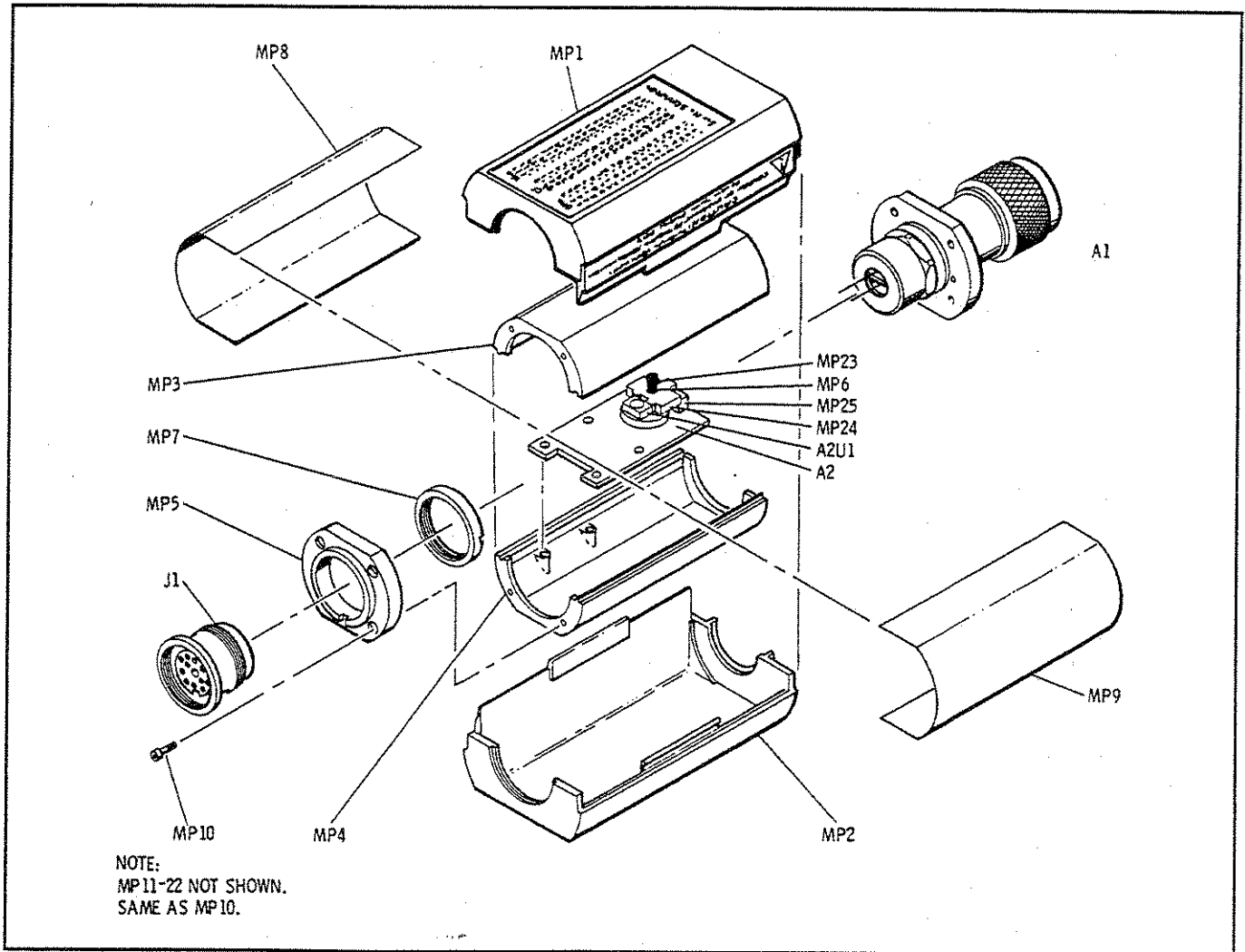

Figure 2. Illustrated Parts Breakdown

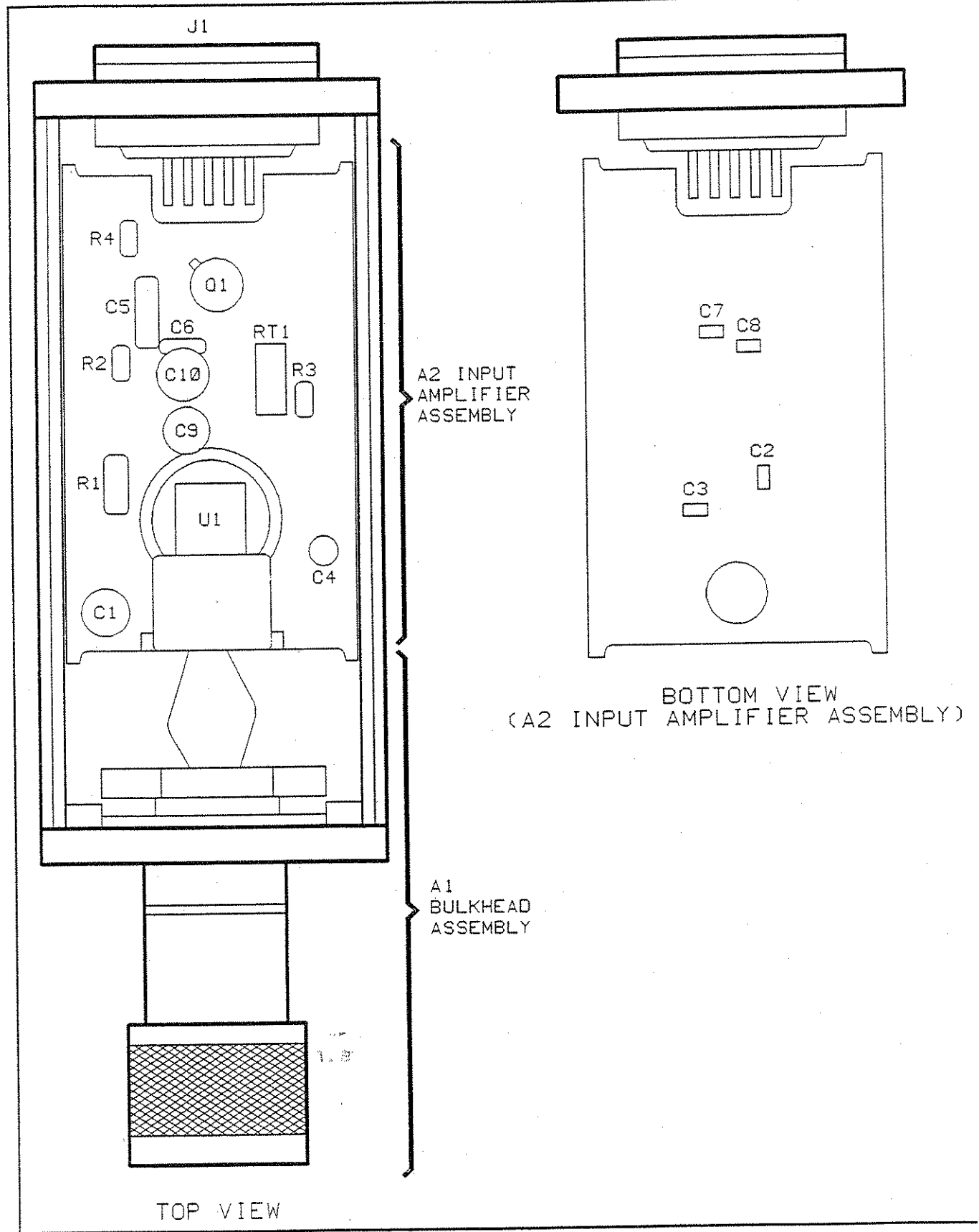

Figure 3. Component and Assembly Locations

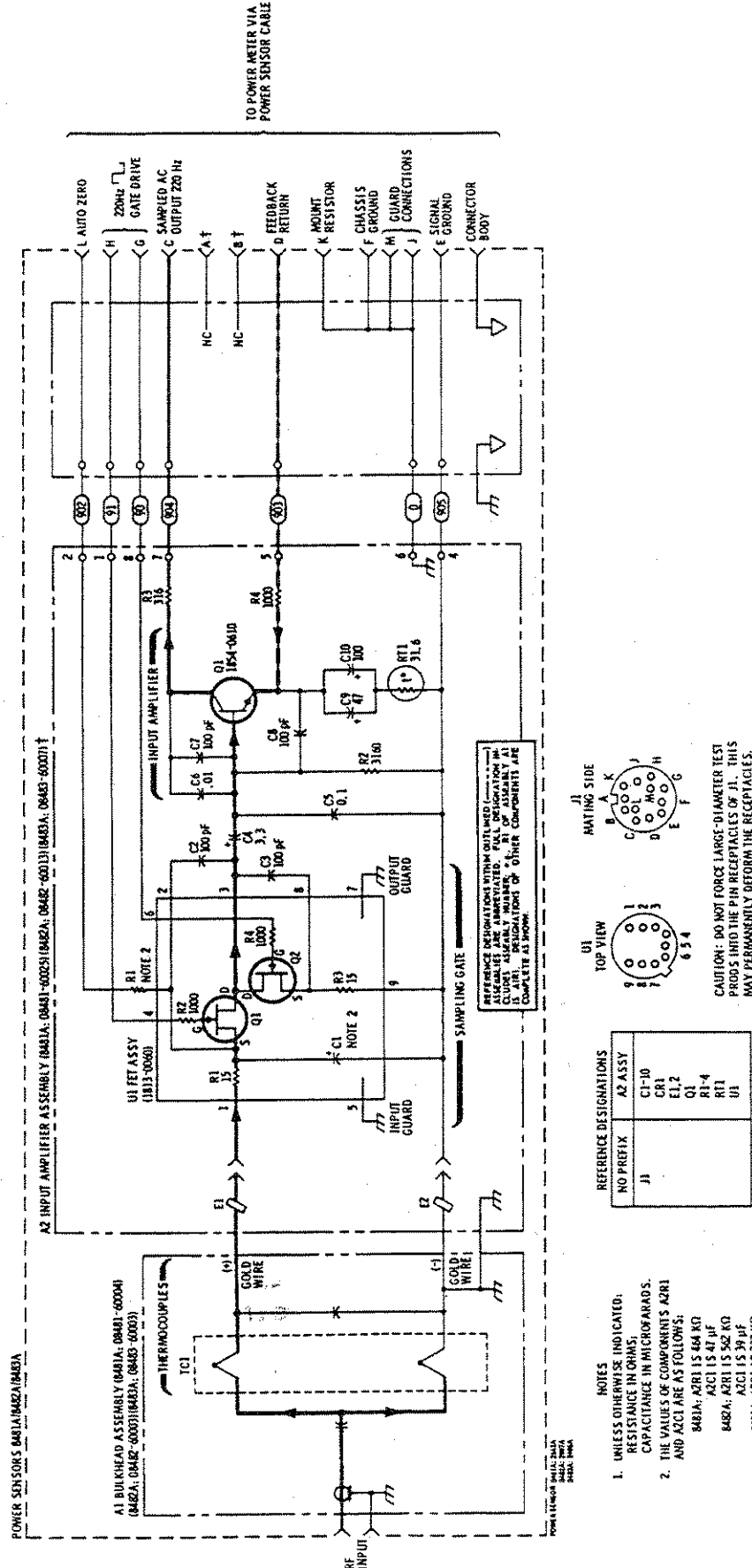
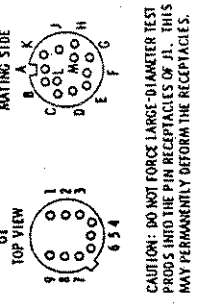

Figure 4. Schematic Diagram



CAUTION: DO NOT FORCE LARGE-DIAMETER TEST PRODS INTO THE PIN RECEPTACLES OF J1. THIS MAY PERMANENTLY DEFORM THE RECEPTACLES.

| NO PREFIX | A2 ASSY |
|-----------|--|
| J1 | C1-10 CR1 EL2 Q1 R1-4 RT1 U1 |

- NOTES
- UNLESS OTHERWISE INDICATED: RESISTANCE IN OHMS; CAPACITANCE IN MICROFARADS. THE VALUES OF COMPONENTS A2R1 AND A2C1 ARE AS FOLLOWS:
8481A, A2R1 IS 464 KΩ
A2C1 IS 47 nF
8482A, A2R1 IS 562 KΩ
A2C1 IS 39 nF
8483A, A2R1 IS 187 KΩ
A2C1 IS 27 nF
 - A1 BULKHEAD ASSEMBLY IS NOT FIELD REPAIRABLE.
 - COMPONENTS OF THE J1 ASSEMBLY ARE NOT SEPARATELY REPLACEABLE.
 - † REFER TO BACKGOATING INFORMATION IN THE APPENDIX.

Table 5. Replacement Parts [1 of 2]

| Reference Designation | HP Part Number | C | D | Qty | Description | Mfr Code | Manufacturer Part Number |
|-----------------------|----------------|---|---|-----|---|----------|--------------------------|
| A1 | 08481-60004 | 3 | | 1 | BULKHEAD, TYPE N (FOR 8481A ONLY) | 28480 | 08481-60004 |
| A1 | 08481-60005 | 4 | | 1 | BULKHEAD, APC-7 (FOR 8481A OPT 001 ONLY) | 28480 | 08481-60005 |
| A1 | 08482-60003 | 3 | | 1 | BULKHEAD, TYPE N (FOR 8482A ONLY) | 28480 | 08482-60003 |
| A1 | 08483-60003 | 4 | | 1 | BULKHEAD, TYPE N (FOR 8483A ONLY) | 28480 | 08483-60003 |
| A1MP1 | 1250-0918 | 0 | | 1 | NUT-CONN RF | | |
| A1MP1 | 1250-1466 | 6 | | 1 | 7MM RF CONNECTION ASSY (OPT 001 ONLY) | | |
| A1MP2 | 1250-0016 | 0 | | 1 | RING, RF CONN | | |
| A1MP3 | 1250-0916 | 9 | | 1 | BODY, RF CONN | | |
| A1MP4 | 1250-0917 | 0 | | 1 | CONNECTOR, RF CONTACT | | |
| A1MP4 | 1250-0816 | 8 | | 1 | 7MM CONTACT (OPT 001 ONLY) | | |
| A1MP5 | 1460-0977 | 7 | | 1 | SPRING, COMPR | | |
| A1MP6 | 5020-3296 | 1 | | 1 | CENTER CONDUCTOR | | |
| A1MP7 | 5020-3297 | 2 | | 1 | SLIDING CONTACT | | |
| A1MP8 | 5040-0306 | 0 | | 1 | INSULATOR | | |
| A1MP9 | 0470-0013 | 2 | | 1 | SEALANT-THD RED | | |
| A1MP10 | 08481-20015 | 2 | | 1 | BULKHEAD | | |
| A1MP11 | 08481-20016 | 3 | | 1 | CAP NUT | | |
| A1MP12 | 08481-40006 | 3 | | 1 | POLYIRON SLUG (8481A ONLY) | | |
| A1MP13 | 08481-60009 | 8 | | 1 | CARTRIDGE ASSY (8481A ONLY) | | |
| A1MP13 | 08481-69009 | 6 | | 1 | RESTORED CARTRIDGE ASSY (8481A ONLY) | | |
| A1MP13 | 08482-60004 | 4 | | 1 | CARTRIDGE ASSY (8482A ONLY) | | |
| A1MP13 | 08483-60006 | 7 | | 1 | CARTRIDGE ASSY (8483A ONLY) | | |
| A1MP14 | 2190-0831 | 0 | | 1 | .010 WASHER-FLAT | | |
| A2 | 08481-60025 | 8 | | 1 | BD AY PWR SENSOR (FOR 8481A) | 28480 | 08481-60025 |
| A2 | 08482-60013 | 5 | | 1 | BD AY PWR SENSOR (FOR 8482A) | 28480 | 08481-60013 |
| A2 | 08483-60007 | 8 | | 1 | BD AY PWR SENSOR (FOR 8483A) | 28480 | 08481-60007 |
| A2 | 0590-1040 | 1 | | 1 | THREADED INSERT-NUT 0-80 .06-IN-LG SST | 46384 | YC3-1505 |
| A2C1 | 0180-2515 | 8 | | 1 | CAP-FXD 47uF 6 V TA | 28480 | 0180-2515 |
| A2C1 | 0180-2781 | 0 | | 1 | (FOR 8481A ONLY) CAP-FXD 39uF 10 V TA | 28480 | 0180-2781 |
| A2C1 | 0180-3210 | 2 | | 1 | (FOR 8482A ONLY) CAP-FXD 47uF 10 V TA | 04213 | 11901161 |
| A2C2 | 0160-0565 | 2 | | 4 | (FOR 8483A ONLY) CAP-FXD 1000pF 100 V | 95275 | VJ0805Y102MF |
| A2C2 | 0160-4306 | 2 | | 1 | (FOR 8481A AND 8482A) CAP-FXD 100pF 100 V | | |
| A2C3 | 0160-0565 | 2 | | 4 | (FOR 8483A ONLY) CAP-FXD 1000pF 100 V | 95275 | VJ0805Y102MF |
| A2C3 | 0160-4306 | 2 | | 1 | (FOR 8481A AND 8482A) CAP-FXD 100pF 100 V | | |
| A2C4 | 0180-0594 | 9 | | 1 | (FOR 8483A ONLY) CAP-FXD 3.3uF 15 V TA | 04222 | 202L1602-335-M4 |
| A2C5 | 0160-3094 | 8 | | 1 | CAP-FXD 0.1uF 100 V | 04222 | SR301C104KAAH |
| A2C6 | 0160-3879 | 7 | | 1 | CAP-FXD 0.01uF 100 V | | SR201C103MAAH |
| A2C7 | 0160-0565 | 2 | | 4 | CAP-FXD 1000pF 100 V | 95275 | VJ0805Y102MF |
| A2C7 | 0160-4306 | 2 | | 1 | (FOR 8481A AND 8482A) CAP-FXD 100pF 100 V | | |
| A2C8 | 0160-0565 | 2 | | 4 | (FOR 8483A ONLY) CAP-FXD 1000pF 100 V | 95275 | VJ0805Y102MF |
| A2C8 | 0160-4306 | 2 | | 1 | (FOR 8481A AND 8482A) CAP-FXD 100pF 100 V | | |
| A2C9 | 0180-2515 | 8 | | 1 | (FOR 8483A ONLY) CAP-FXD 47uF 6 V TA | | 202L6301-476-M7-552 |
| A2C10 | 0180-2545 | 4 | | 1 | CAP-FXD 100uF 4 V TA | 04713 | 202L6301-107-M6-552 |
| A2Q1 | 1854-0610 | 0 | | 1 | TRANSISTOR NPN SI TO-46 FT=800MHZ | 28480 | 0698-3260 |
| A2R1 | 0698-3260 | 9 | | 1 | RESISTOR 464K +-1% .125W TF TC=0+-100 | 28480 | 0757-0483 |
| A2R1 | 0757-0483 | 8 | | 1 | (FOR 8481A ONLY) RESISTOR 562K +-1% .125W TF TC=0+-100 | 28480 | 0698-8352 |
| A2R1 | 0698-8352 | 9 | | 1 | (FOR 8482A ONLY) RESISTOR 787K +-1% .125W TF TC=0+-100 | 28480 | |
| A2R1 | | | | | (FOR 8483A ONLY) | | |

Table 5. Replacement Parts [2 of 2]

| Reference Designation | HP Part Number | C D | Qty | Description | Mfr Code | Manufacturer Part Number |
|-----------------------|----------------|-----|-----|---|----------|--------------------------|
| A2R2 | 0698-7248 | 1 | 1 | RESISTOR 3.16K +-1% .05W TF TC=0+-100 | 24546 | C3-1/8-T0-3161-F |
| A2R3 | 0698-7224 | 3 | 1 | RESISTOR 316K +-1% .05W TF TC=0+-100 | 24546 | C3-1/8-T0-316R-F |
| A2R4 | 0698-7236 | 7 | 1 | RESISTOR 1K +-1% .05W TF TC=0+-100 | 24546 | C3-1/8-T0-1001-F |
| A2RT1 | 0811-3210 | 1 | 1 | RESISTOR 31.6 +-5% .05W TF TC=+5040+-250 | 14140 | 1409-1/20-31R6-J |
| A2U1 | 1813-0060 | 8 | 1 | IC MISC TO-8 PKG | 28480 | 1813-0060 |
| | | | | A2 MISCELLANEOUS PARTS | | |
| | 0590-1040 | 1 | 1 | THREADED INSERT-NUT 0-80 .06-IN-LG SST | 28480 | 0590-1040 |
| | 5040-6938 | 6 | 1 | SPACER | 28480 | 5040-6938 |
| | | | | CHASSIS PARTS | | |
| J1 | 08481-60024 | 7 | 1 | CONNECTOR ASSEMBLY, 12-PIN | 28480 | 08481-60024 |
| MP1 | 08481-40002 | 9 | 2 | SHELL, PLASTIC | 28480 | 08481-40002 |
| MP2 | 08481-40002 | 9 | 2 | SHELL, PLASTIC | 28480 | 08481-40002 |
| MP3 | 08481-20011 | 8 | 2 | CHASSIS | 28480 | 08481-20011 |
| MP4 | 08481-20011 | 8 | 2 | CHASSIS | 28480 | 08481-20011 |
| MP5 | 08481-20008 | 3 | 1 | END BELL | 28480 | 08481-20008 |
| MP6 | 1460-1978 | 0 | 1 | SPRING-CPRSN .088-IN-OD .188-IN-OA-KG | 28480 | 1460-1978 |
| MP7 | 1251-3363 | 8 | 1 | NUT-AUDIO CONN | 28480 | 1251-3363 |
| MP8 | 08481-00002 | 5 | 2 | SHIELD | 28480 | 08481-00002 |
| MP9 | 08481-00002 | 5 | 2 | SHIELD | 28480 | 08481-00002 |
| MP10 | 3030-0954 | 1 | 9 | SCREW-SKT HD CAP 0-80 .188-IN-LG SST-304 | 28480 | 3030-9054 |
| MP11 | 3030-0954 | 1 | 9 | SCREW-SKT HD CAP 0-80 .188-IN-LG SST-304 | 28480 | 3030-9054 |
| MP12 | 3030-0954 | 1 | 9 | SCREW-SKT HD CAP 0-80 .188-IN-LG SST-304 | 28480 | 3030-9054 |
| MP13 | 3030-0954 | 1 | 9 | SCREW-SKT HD CAP 0-80 .188-IN-LG SST-304 | 28480 | 3030-9054 |
| MP14 | 3030-0954 | 1 | 9 | SCREW-SKT HD CAP 0-80 .188-IN-LG SST-304 | 28480 | 3030-9054 |
| MP15 | 3030-0954 | 1 | 9 | SCREW-SKT HD CAP 0-80 .188-IN-LG SST-304 | 28480 | 3030-9054 |
| MP16 | 3030-0954 | 1 | 9 | SCREW-SKT HD CAP 0-80 .188-IN-LG SST-304 | 28480 | 3030-9054 |
| MP17 | 3030-0954 | 1 | 9 | SCREW-SKT HD CAP 0-80 .188-IN-LG SST-304 | 28480 | 3030-9054 |
| MP18 | 3030-0954 | 1 | 9 | SCREW-SKT HD CAP 0-80 .188-IN-LG SST-304 | 28480 | 3030-9054 |
| MP19 | 3030-0422 | 8 | 4 | SCREW-SKT HD CAP 0-80 .188-IN-LG SST-302 | 00000 | ORDER BY DESCRIPTION |
| MP20 | 3030-0422 | 8 | 4 | SCREW-SKT HD CAP 0-80 .188-IN-LG SST-302 | 00000 | ORDER BY DESCRIPTION |
| MP21 | 3030-0422 | 8 | 4 | (USED TO MOUNT THE PRINTED CIRCUIT BOARD) | 00000 | ORDER BY DESCRIPTION |
| MP22 | 3030-0422 | 8 | 4 | SCREW-SKT HD CAP 0-80 .188-IN-LG SST-302 | 00000 | ORDER BY DESCRIPTION |
| MP23 | 3030-0436 | 4 | 1 | (USED TO MOUNT THE PRINTED CIRCUIT BOARD) | 00000 | ORDER BY DESCRIPTION |
| MP24 | 5040-6939 | 7 | 1 | SCREW-SKT HD CAP 0-80 .5-IN-LG SST-300 | 28480 | 5040-6939 |
| MP25 | 5040-6940 | 0 | 1 | CLAMP | 28480 | 5040-6940 |
| MP26 | 1250-0597 | 2 | 1 | BLOCK | | |
| MP27 | 08481-80002 | 3 | 1 | ADAPTER COAX STR M-N F-N | 28480 | 08481-80002 |
| MP28 | 08482-80002 | 4 | 1 | 8481A ID LABEL | 28480 | 08482-80002 |
| MP29 | 08483-80001 | 6 | 1 | 8482A ID LABEL | 28480 | 08483-80001 |
| MP30 | 08486-80001 | 7 | 1 | 8483A ID LABEL | 28480 | 08486-80001 |
| MP31 | 08481-80005 | 6 | 1 | CAL LABEL (BLANK) | 28480 | 08481-80005 |
| MP32 | 08486-80005 | 1 | 1 | MYLAR TAPE (COVERS CAL LABEL) | 26480 | 08486-80005 |
| MP33 | 7120-2422 | 7 | 1 | INFO LABEL (SIDE) | 26480 | 7120-2422 |
| | | | | WARNING LABEL (SIDE) | | |

Table 6. Code List of Manufacturers

| Mfr Code | Manufacturer Name | Address | | Zip Code |
|-------------|---------------------------------|------------|----|----------|
| | | | | |
| 00000 | ANY SATISFACTORY SUPPLIER | MINEOLA | NY | 11501 |
| 04213 | CADDELL-BURNS MFG CO INC | MANCHESTER | NH | 03130 |
| 14140 | EDISON ELEK DIV MCGRAW-EDISON | BRADFORD | PA | 16701 |
| 24546 | CORNING GLASS WORKS BRADFORD) | PALO ALTO | CA | 94304 |
| 28480 | HEWLETT-PACKARD CO CORPORATE HQ | SAN DIEGO | CA | 92138 |
| 51959 | VICLAN INC | | | |

Service

Service instructions consist of principles of operation, troubleshooting, and repairs. Test equipment which meets or exceeds the critical specifications in table 3 may be used in place of the recommended instruments for troubleshooting the Power Sensor.

Note



Check your warranty. Opening the Power Sensor will void warranty.

Principles of Operation

For the following discussion, refer to figure 4 Schematic Diagram and figure 5 Operational Amplifier. The operational amplifier is made up of the Power Sensor input amplifier, A2Q1, and the first amplifier stage in the power meter.

For additional information on thermocouple sensors, refer to HP Application Note 64-1, "Fundamentals of RF and Microwave Power Measurements".

The A1 Bulkhead Assembly provides a 50 ohm load (HP 8481A and 8482A) or a 75 ohm load (HP 8483A) to the RF signal applied at the RF INPUT. The rf signal is coupled through a dc blocking capacitor and absorbed by the thermocouples which generate a dc voltage proportional to the rf input power. The dc voltage is routed from the thermocouples to the input amplifier on gold wires to reduce undesired thermocouple effects. The gold wires pass through ferrite beads A2E1 and A2E2 which are located in the black plastic block. (See figure 2.) The ferrite beads increase the self inductance of the gold wires causing this portion of the wires to provide the properties of an rf choke. The result is to minimize rf feedthrough to the A2 Input Amplifier Assembly.

The dc output from the bulkhead assembly is applied to the two field effect transistors (FETs) in A2U1. These transistors function as a sampling gate or chopper. The sampling rate is controlled by a 220 Hz square wave supplied by the power meter. The amplitude of the sampling gate output (at pin 3 of A2U1) is a 220 Hz square wave proportional to the power input. The sampled 220 Hz ac output is applied to the input amplifier A2Q1 which is the input stage for an operational amplifier (figure 5). The ac gain of the operational amplifier is approximately 700.

A dc feedback voltage from the power meter Auto Zero circuit is coupled to the input of FET A2U1Q1 to set the zero level. The voltage is developed across the voltage divider consisting of A2R1 and the series resistance of the thermocouple A1TC1.

When the Power Sensor is used with an HP Power Meter, the short to ground at J1-K (Mount Resistor) causes the power meter to automatically select the proper measurement range of -30 to +20 dBm. With the HP 435 series Power Meter this short serves no function.

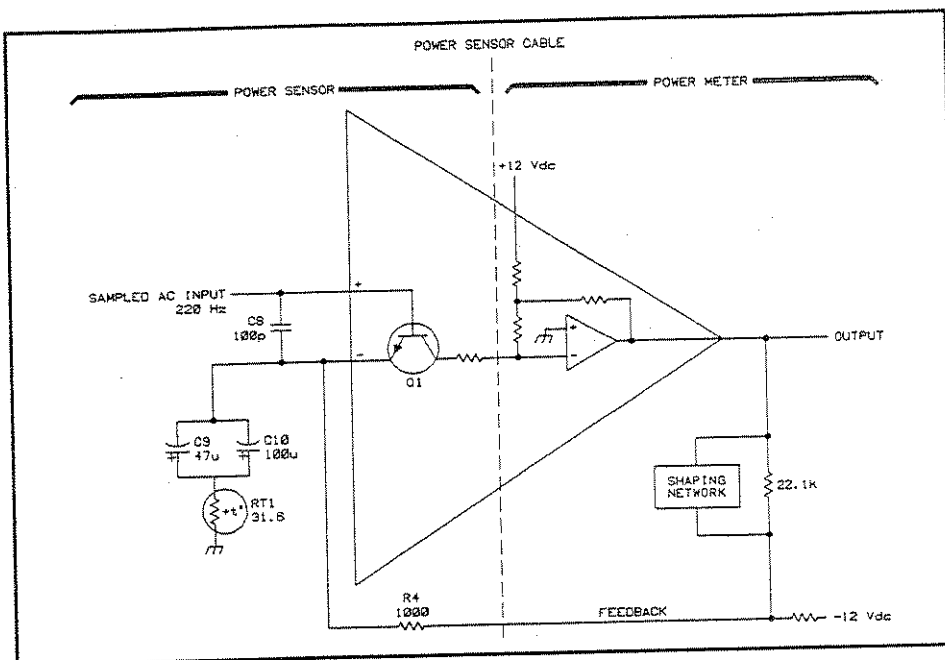

Figure 5. Operational Amplifier

Troubleshooting

The troubleshooting information is intended to first isolate the Power Sensor or power meter as the defective component. When the Power Sensor is isolated, troubleshooting information is intended to identify A1 Bulkhead Assembly or A2 Input Amplifier Assembly as the defective component.

Before you open the Power Sensor to continue with the troubleshooting procedures, try the substitution method of elimination. Use another Hewlett-Packard power meter, known to be in good operating condition, with the suspected power sensor and cable. If the same problem occurs with the "known good" power meter, substitute a "known good" power sensor cable.

Troubleshooting should be performed with the Power Sensor opened, the printed circuit board exposed. See "Disassembly" close to the end of this manual.

When a failed assembly has been identified, go to "Repair" directly following "Troubleshooting".

Caution



Excessive power will damage the thermocouples.

Power Meter

To ensure the power meter is providing the correct 220 Hz signal, check the following levels of the square wave with an oscilloscope.

- At the white-black wire: -0.05 ± 0.05 Vdc (top of square wave).
- At the white-brown wire: -9.0 Vdc (bottom of square wave).

If the levels are correct the Power Sensor is at fault. Continue troubleshooting A1 Bulkhead Assembly. If the levels are incorrect, the power meter is at fault. Refer to the power meter service manual for troubleshooting information.

Power Sensor

The most common cause of Power Sensor failure is the application of power levels beyond the specified tolerance. The second most common cause of failure is applying torque to the body of the Power Sensor. Either of these common causes will damage the bulkhead cartridge unit (which holds the thermocouples). If this happens, the fault will cause a short or an open between the two gold wires.

Caution



Be extremely careful when measuring across the gold wires. They are delicate and can be damaged easily.

1. Disconnect all cables from the power sensor.
2. Remove the clamp holding the two gold wires.
3. Resistance measured between the two gold wires from the A1 Bulkhead Assembly should be 200 ± 10 ohms (HP 8481A), 245 ± 12.5 ohms (HP 8482A), or 375 ± 17.5 ohms (HP 8483A). If you cannot obtain the proper resistance (failure is usually indicated by an open circuit) the A1 Bulkhead Assembly is defective. If the resistance is correct continue to "A2 Input Amplifier".

A2 Input Amplifier Assembly

It is extremely rare for the A2 Assembly to fail. Eliminate the power meter, the bulkhead assembly and the connectors before suspecting the A2 Assembly.

In most cases, the operational amplifier (made up of A2Q1 and the first amplifier of the power meter, figure 5) is operating correctly if the dc voltage on the metal cover of A2Q1 (collector) is -70 ± 30 mV dc. Refer to the schematic to troubleshoot further.

Repair

Power Sensor repair consists of A1 Bulkhead replacement or repair and A2 Input Amplifier replacement.

Repair Strategy

Bulkhead. You can choose to either replace your A1 Bulkhead Assembly, or repair it yourself. We recommend replacing the A1 Bulkhead with a new or restored bulkhead over attempting to rebuild it. A restored Bulkhead is rebuilt and calibrated at the factory. It comes with a calibration report and new calibration sticker for your sensor.

If you decide to repair the bulkhead yourself, you should have an HP 11760S Automated Power Sensor Calibration System and, when repairs

- b. Place a very small amount (use the point of a wooden toothpick) of red anaerobic sealant A1MP9, on the threads of A1MP4. Be careful not to get any sealant near the insulator.
- c. Use your fingers to screw the center contact A1MP4 into the center conductor A1MP6 until tight. The round insulator should be squeezed tight enough so that it will not rotate. *Do not scratch or burr the two shafts.*
- d. Place the spring A1MP5 into A1MP6.
- e. Patiently place the sliding contact (snowflake) A1MP7 so that the snowflake fingers (without being damaged) surround the spring and press against the inner surface of center conductor A1MP6. The snowflake should spring back when pressed.

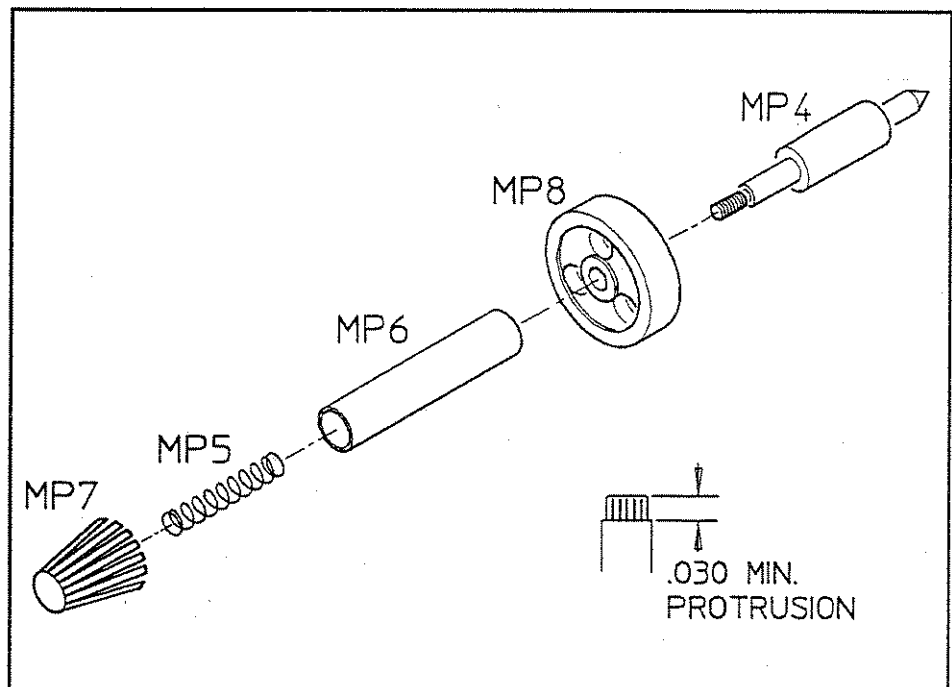

Figure 7. A1 Bulkhead Center Contact Assembly

7. Screw the bulkhead into the center pin assembly as shown in figure 8.
8. Tighten in place to 50 ± 5 in-lbs (565 N·cm)
8. Use the appropriate gage to verify pin depth. When pin depth is correct go to next step, "Cartridge Replacement".

Cartridge Replacement. If you do not need to replace the inner and outer conductors of your bulkhead, start here. The procedure assumes the bulkhead assembly is removed from the Power Sensor.

9. Order one cartridge replacement A1MP13 from the replaceable parts list.

10. Place the bulkhead on its face, connector side down with the gold wires pointing up. Using a 5/8 in (16 mm) open end wrench, remove the cap nut A1MP11.
11. Turn the bulkhead assembly upside down and shake out the old parts. Watch where the polyiron slug A1MP12 rolls to and keep it for the new cartridge unit.

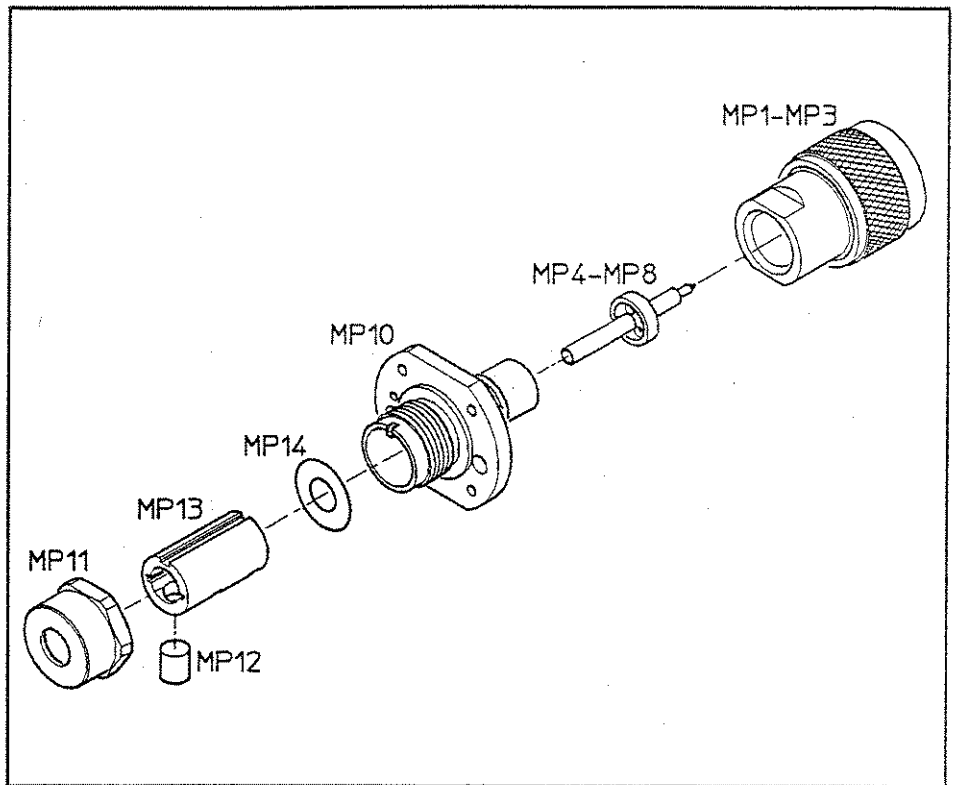

Figure 8. A1 Bulkhead Illustrated Parts Breakdown

Caution



The gold wires on the new cartridge unit are easily damaged and cannot be repaired.

12. Slip washer A1MP14 inside the bulkhead A1MP10. Now load in the new cartridge unit with the gold wires pointing out, holding the polyiron slug inside the unit until everything is in place.
13. Press the top of the bulkhead. A slight springlike action indicates the cartridge is properly seated. If the cartridge unit does not spring a little when pressed, carefully remove the cartridge unit (so you do not damage the gold wires) and use a thinner washer, A1MP15. If it still does not spring, you should rebuild the center conductor (step 6) with new parts.

Caution

Damage can occur to both the cartridge and center conductor if they are not properly mated. If no springlike action (or "give") is present remove the cartridge assembly and rebuild the center conductor with new parts.

14. Tighten the cap nut to finger tight then torque the cap nut to to 35 ± 5 in-lbs (395 N·cm).
15. Reassemble the power sensor using the reassembly procedure at the end of this manual.
16. Test for SWR.
17. Check the FET balance using the procedure prior to Replaceable Parts. (If you were careful not to disturb the wires above the PC board (A2) this step may not be necessary.)
18. Calibrate the Sensor using your HP 11760S Automated Power Sensor Calibration System. Place the new sticker on the Power Sensor cover.

A2 Assembly Replacment and Soldering

To replace the A2 printed circuit assembly, you will have to perform some soldering to remove and replace the wires from Connector J1. Remember the Power Sensor is a highly sensitive device. As such, it is affected by very small temperature differences between its components. After doing any soldering in the unit, wait several hours for the unit to reach thermal equilibrium before using or testing it.

1. Use a temperature controlled 600°F (311°C) with a zero crossover tip.
2. Use a low temperature RMA flux SN 62 solder.
3. Do not attempt to remove flux residue from around solder joints. We have found that using a cleaning solution spreads the flux in a thin sticky layer over the entire assembly.

Connector Cleaning

Keeping in mind its flammable nature, a solution of pure isopropyl or ethyl alcohol can be used to clean connectors.

1. 3

Caution

The RF connector bead deteriorates when contacted by any chlorinated or aromatic hydrocarbon such as acetone, trichlorethane, carbon tetrachloride, and benzene.

Do not attempt to clean connectors with anything metallic such as pins or paper clips.

Clean the connector face by first using a blast of compressed air. If the compressed air fails to remove contaminants use a cotton swab dipped in isopropyl or ethyl alcohol. If the swab is too big, use a round wooden toothpick wrapped in a lint free cloth dipped in isopropyl or ethyl alcohol.

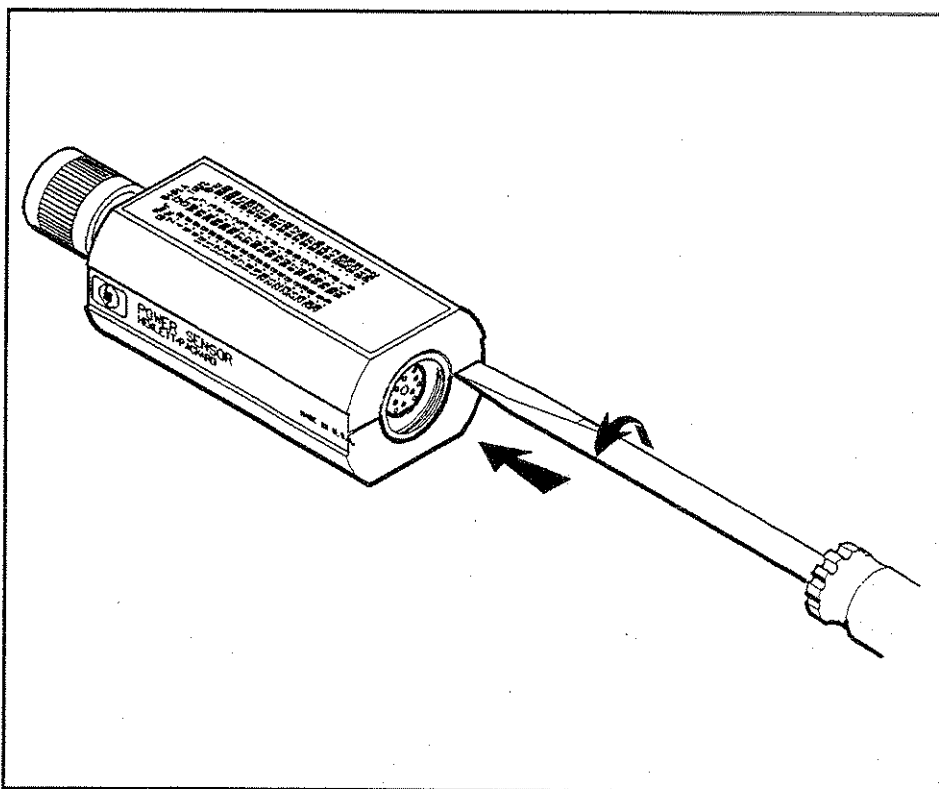

Figure 9. Removing the Power Sensor's Cover

Disassembly Procedure

Disassemble the Power Sensor by performing the following steps:

Caution



Disassembly must be performed in sequence described below, otherwise damage may be caused to the two gold wires between the bulkhead assembly and the input amplifier assembly. If these wires are damaged the A1 Bulkhead Assembly must be repaired or returned to the factory for repair.

Note



Every Power Sensor has an individually prepared graph on the housing. If more than one power sensor is disassembled at a time, be sure to mate the correct Power Sensor and housing when reassembling.

1. Insert the blade of a large screwdriver between the two-piece plastic shell at the rear of the Power Sensor. Gently pry the sections apart. (See figure 9.)
2. Proceed to the other side of the connector and again pry the cover sections apart. Remove the shells and magnetic shields.
3. Position the Power Sensor as shown in figure 8 (top). The small hole 5 should be on the left side of the RF input connector. Remove the allen cap screws 1, 2, 10, and 13. Loosen 11 and 12. Remove the upper chassis from the Power Sensor.
4. Remove the spring clamp cap screw 7 to free the gold leads which come from the Bulkhead Assembly.
5. Remove cap screws 3, 4, and 5.
6. Slide the Bulkhead Assembly straight out from the chassis.
7. Remove cap screws 8, 9, 11, 12, 14, and 15.
8. Lift the A2 Input Amplifier and J1 connector out of the chassis.

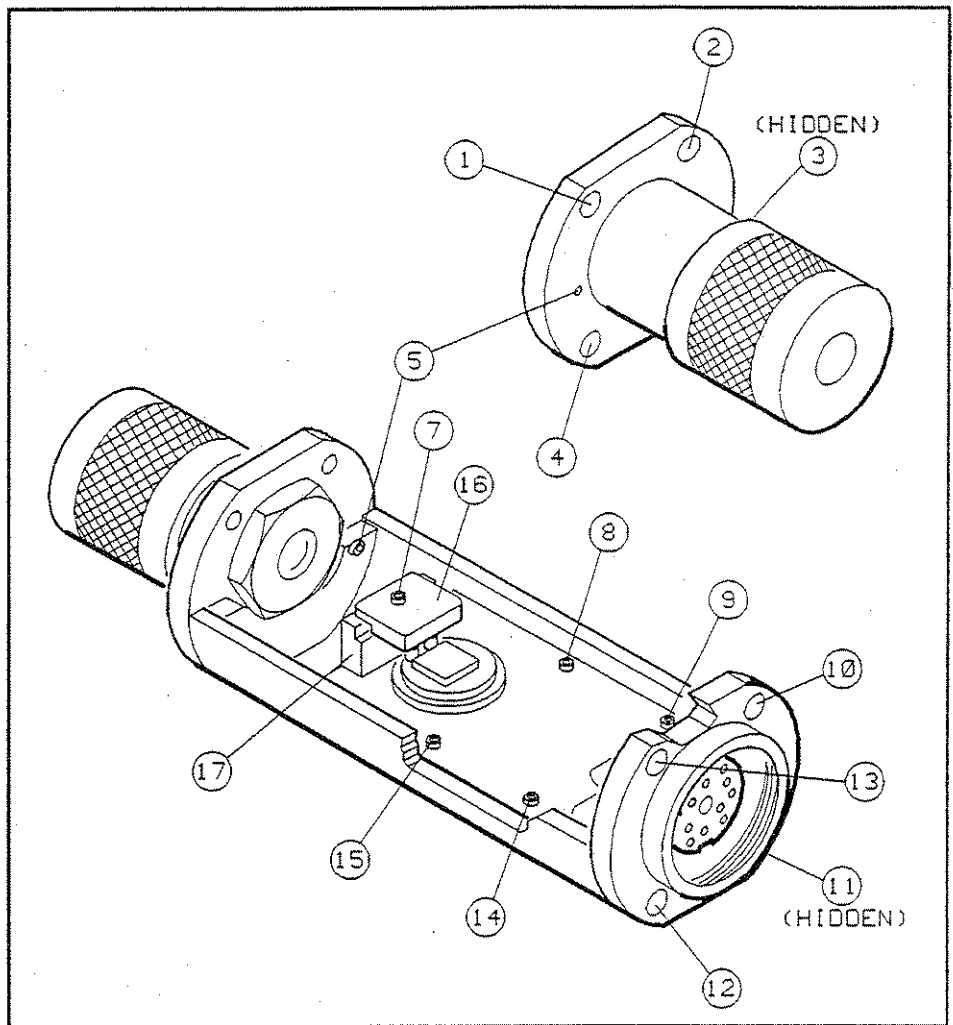

Figure 10. Power Sensor Hardware Locations

Reassembly Procedures

Caution



The gold wires connecting the A1 Bulkhead Assembly and the A2 Input Amplifier Assembly are extremely delicate and may be easily broken. Be careful when working around them.

1. Set the printed circuit board and connector into place as shown in figure 10, bottom view.
2. Insert cap screws 8, 9, 11, 12, 14, and 15 but do not tighten.
3. Center the circuit board so there is equal air gap between each side and the chassis. Tighten 8, 9, 14, and 15.
4. With small hole 5 to the left, carefully insert the gold leads on A1 bulkhead assembly through the holes in the black plastic guide on A2 input amplifier.
5. Insert screw 3, 4, and 5. Tighten only screw 5.

MANUAL CHANGES

This Appendix contains information for adapting this manual to instruments for which the content does not apply directly.

To adapt this manual to your instrument, refer to table I-1 and make the changes listed opposite your instrument serial number.

Table I-1. Manual Changes by Serial Number

| Instrument | Serial Prefix or Number | Make Manual Changes |
|------------|-------------------------|---------------------|
| HP 8481A | 1550A | H,F,D,B,A |
| | 1926A | H,F,D,B |
| | 2237A | H,F,D |
| | 2349A | H,G,F |
| | 2552A | H |
| HP 8482A | 1551A | H,G,D,B,A |
| | 1925A | H,G,D,B |
| | 2237A | H,G,D |
| | 2349A | H,G |
| | 2607A | H |
| HP 8483A | 1602A | H,G,E,D,C,B,A |
| | 1925A | H,G,E,D,C,B |
| | 2243A | H,G,E,D,C |
| | 2329A | H,G,E,D |
| | 2351A | H,G,E |
| | 2405A | H,G, |
| | 2623A | H |

CHANGE INSTRUCTIONS

CHANGE A

Page 10, Table 5:

Change A2 part numbers as follows:

08481-60025 to 08481-60017

08482-60013 to 08482-60005

08483-60007 to 08483-60004

Change J1 to 1251-3228 CONNECTOR, 12 PIN FEMALE MULTICONTACT 90949 91T-3638.

Page 9, Figure 4:

Replace Figure 4 with Figure I-2.

6. Using tweezers, position the ends of the gold wires over the electrical pads.

Caution

DO NOT tighten clamp screw 6 excessively or the FET circuit may be broken.

7. Place and hold plastic clamp 16 over the gold wires. As you tighten the clamp screw, watch the compression spring. Tighten the clamp screw 7 only until the spring coils touch. Any further tightening could damage the FET circuit.
8. Place the upper chassis in position and insert cap screws 1, 2, 10, and 13.
9. Tighten 1, 2, 3, and 4.
10. Tighten 10, 11, 12, and 13.
11. Place the plastic shells, magnetic shields, and the chassis together as shown in figure 1. Snap the plastic shells together.

CHANGE B

Page 10, Table 5:

MP6. The part number for MP6 was originally 1460-1224, however, 1460-1978 is the recommended replacement.

Page 9, Figure 4:

Replace the shaded area to the right of the A2 Input Amplifier Assembly with Figure I-1.

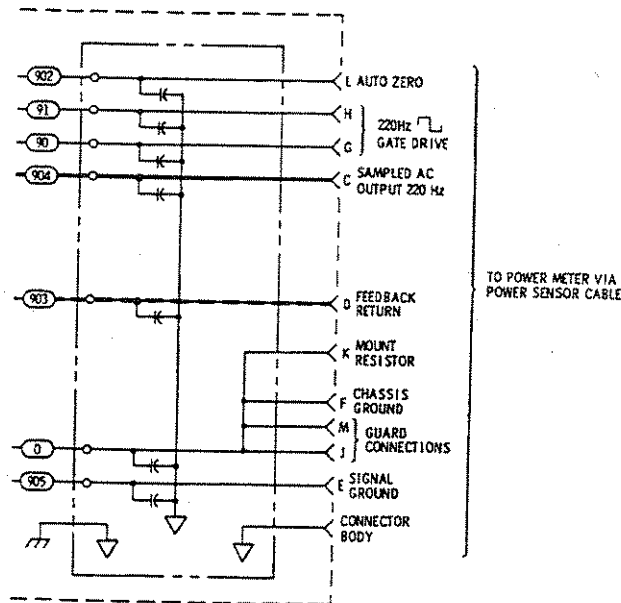

Figure I-1. J-1 Partial Schematic Diagram (P/O Change 2)

Page 11, Table 5:

MP 30. Change the part number and description of MP30 to:
MP30 08483-00002 CD7 LABEL-CAL INSTRUCTIONS.

CHANGE D

Page 9, Figure 4:

In the shaded area to the right of the schematic, connect pin A to the junction of pins F, M, and J.

CHANGE E

Page 2, paragraph 18:

Replace the sentence which reads:

“The REF CAL FACTOR, on the power sensor label, has been adjusted for the impedance mismatch.”

with:

“The CAL FACTOR at 50 MHz must be multiplied by 0.96 to determine the REF CAL FACTOR.”

Page 10, Table 5:

MP10-MP18. The part number for MP10—MP18 was originally 3030-0422, however, 3030-0954 is the recommended replacement.

Page 11, Table 5:

MP 30. Change the part number and description of MP30 to:
08483-00006 CD1 LABEL-CAL INSTRUCTIONS.

CHANGE F

Page 11, Table 5:

MP27. Replace MP27 with the following:

7120-3118 CD0 LABEL, ID-LEFT (HP 8481A ONLY)

CHANGE G

Page 11 Table 6-3:

MP28. Replace MP28 with the following:

7120-4199 CD9 NAMEPLATE .315-IN-WD 2.745-IN-LG AL.

MP29. Replace MP29 with the following:

7120-4204 NAMEPLATE .315-IN-WD 2.745-IN-LG AL.

CHANGE H

Page 8, Figure 3:

Replace figure 3, "Component and Assembly Locations", with figure I-3.

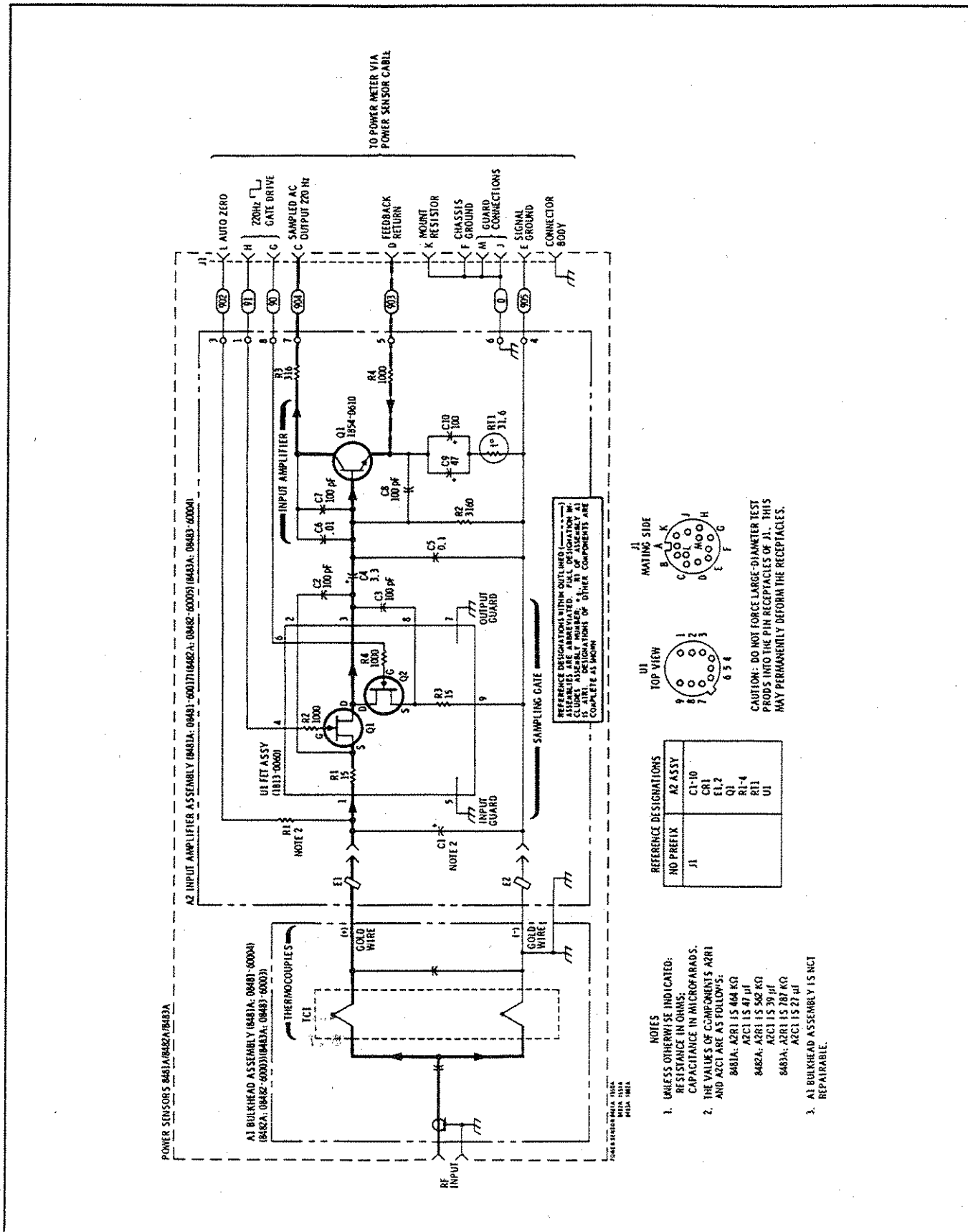

Figure I-2. Schematic Diagram (P/O Change 4)

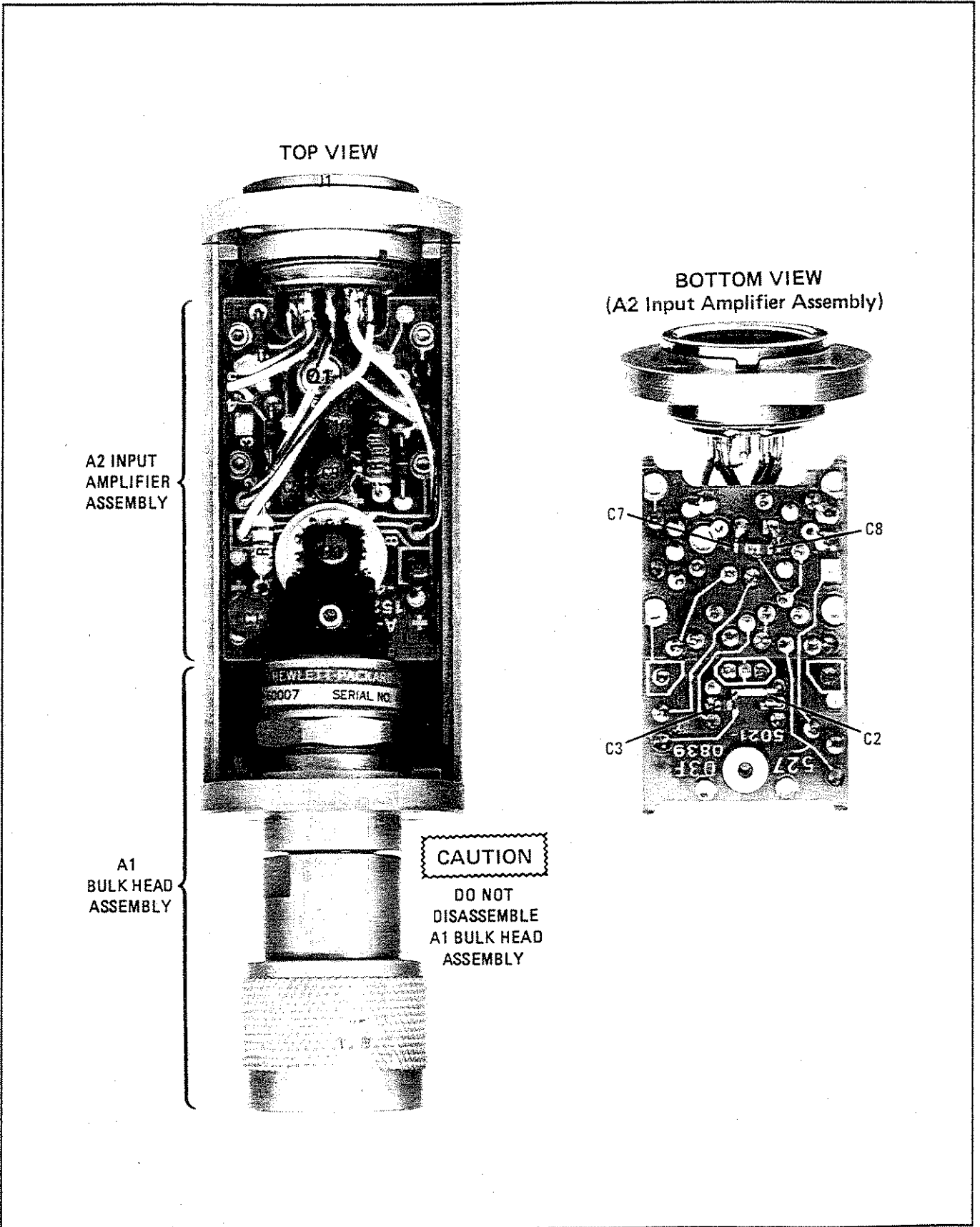

Figure I-3. Component and Assembly Locations

REGIONAL SALES AND SUPPORT OFFICES

For information relating to Sales or Support of Hewlett-Packard products, first contact your local Hewlett-Packard office listed in the white pages of your telephone directory. If none is listed locally, contact Hewlett-Packard at one of the offices listed below to obtain the address or phone number of the Sales or Support office nearest you.

The format for telephone numbers is listed as: (country code/area code or city code) local number. For example, at European Operations HQ, the main site number is listed as: (41/22)780.8111; 41 is the country code, 22 is the city code, and 780.111 is the local number.

EUROPEAN MULTICOUNTRY

(Scandinavia, Middle East,
Africa, Eastern Europe)

Hewlett-Packard S.A.
150, route du Nant-d'Avril
P.O. Box 1217 Meyrin
2/Geneva
Switzerland
Tel: (41/22)780.8111
Fax: (41/22)780.8609

FRANCE

Hewlett-Packard France
Parc d'Activite du Bois Briard
2, avenue du Lac
91040 Evry Ce'dex
France
Tel: (33/1)69 91 80 00
Fax: (33/1)69 91 84 32

GERMANY

Hewlett-Packard GmbH
Herrenberger Strasse 130
D-7030 Boblingen
West Germany
Tel: (49/7031)14-0
Fax: (49/7031)14-2999

ITALY

Hewlett-Packard Italiana
S.p.A.
Via Giuseppe di Vittorio, 9
20063 Cernusco sul Naviglio,
Milan
Italy
Tel: (39/2)921 001
Fax: (39/2)921 044 73

UNITED KINGDOM

Hewlett-Packard Ltd.
Nine Mile Ride
Wokingham, Berkshire RG11
3LL
England
Tel: (44/344)773100
Fax: (44/344)763526

AUSTRALASIA REGION

Hewlett-Packard Australia Ltd.
31-41 Joseph Street
Blackburn, Victoria 3130
Australia
Tel: (61/3)895-2895
Fax: (61/3)898-7831

CANADA

Hewlett-Packard (Canada)
Ltd.
6877 Goreway Drive
Mississauga, Ontario L4V 1M8
Canada
Tel: (1/416)678-9430
Fax: (1/416)678-9421

FAR EAST REGION

Hewlett-Packard Asia Ltd.
22nd Floor
West Tower, Bond Centre
89 Queensway, Central
Hong Kong
Tel: (852)848-7777
Fax: (852)868-4997

JAPAN

Yokogawa-Hewlett-Packard
Ltd.
3-29-21, Takaido-Higashi
Suginami-Ku, Tokyo 168
Japan
Tel: (81/3)331-6111
Fax: (81/3)331-6631

LATIN AMERICA REGION

HP Mexico, S.A. de C.V.
Monte Pelvoux No. 111
Fracc. Lomas de Virreyes
11000 Distrito Federal
Mexico
Tel: (52/5)202 01 55
Fax: (52/5)540 42 08

EASTERN U.S.A. REGION

Hewlett-Packard Company
4 Choke Cherry Road
Rockville, MD 20850, USA
Tel: (1/301)670-4300
Fax: (1/301)670-4531

MIDWEST U.S.A. REGION

Hewlett-Packard Company
5201 Tollview Drive
Rolling Meadows, IL 60008,
USA
Tel: (1/708)255-9800
Fax: (1/708)259-4995

SOUTHERN U.S.A. REGION

Hewlett-Packard Company
2015 South Park Place
Atlanta, GA 30339, USA
Tel: (1/404)955-1500
Fax: (1/404)980-7669

WESTERN U.S.A. REGION

Hewlett-Packard Company
5161 Lankershim Blvd.
N. Hollywood, CA 91601-
3794,
USA
Tel: (1/818)505-5600
Fax: (1/818)505-5875

OTHER INTERNATIONAL AREAS

Hewlett-Packard Company
3495 Deer Creek Road
Palo Alto, CA 94304-1316,
USA
Tel: (1/415)857-5027
Fax: (1/415)857-7045