

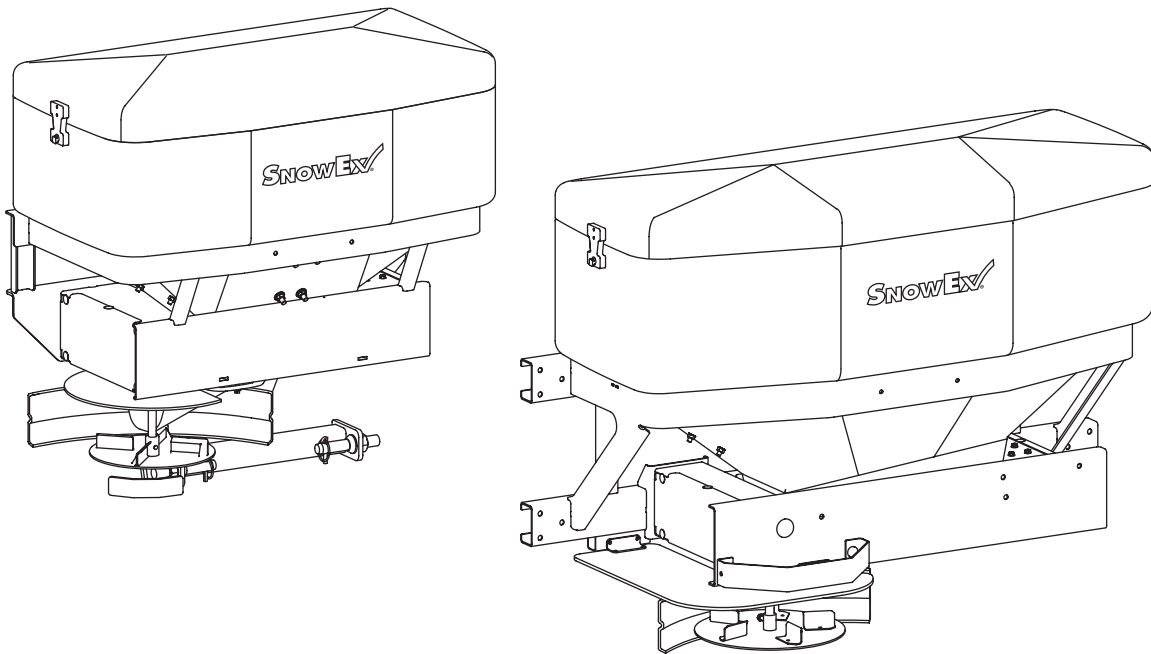

SP-1575, SP-1875 Bulk Pro Tailgate Spreader

Owner's Manual and Installation Instructions
Original Instructions



⚠ CAUTION

Read this manual before installing or
operating the spreader.

This manual is for SnowEx® SP-1575 spreaders with serial numbers beginning 141114 and higher
and SP-1875 spreaders with serial numbers beginning 141112 and higher.

This document supersedes all editions with an earlier date.

TABLE OF CONTENTS

INTRODUCTION	5	OPERATING THE SPREADER	18
Warranty Registration	5	Cab Control.....	18
OWNER'S INFORMATION FORM	5	Starting and Stopping the Motor	18
SAFETY INFORMATION	6–9	Adjusting Auger/Spinner Speed	18
LOADING	10	Auto-Reverse (AR) Feature.....	19
Certification.....	10	Vibrator Function	19
Determining Vehicle Payload.....	11	Alarm Codes.....	19
Approximate Material Weights.....	11	Controlling Flow of Material	19
MOUNTING THE SPREADER	12	Spreading Tips.....	19
Model SP-1875	12	MAINTENANCE	20
Model SP-1575.....	12	Lubrication	20
License Plate Installation	13	After Each Use.....	20
ELECTRICAL HARNESS INSTALLATION	14	At the End of Each Season or after	
HARNESS & CONTROL DIAGRAMS	16	Extended Storage.....	20
		Storage	20
		TROUBLESHOOTING	21

INTRODUCTION

This manual has been prepared to acquaint you with the safety information, operation and maintenance of your new tailgate spreader. Please read this manual carefully and follow all recommendations. This will help ensure profitable and trouble-free operation of your spreader. Keep this manual accessible. It is a handy reference in case minor service is required.

When service is necessary, bring your spreader to your distributor. They know your spreader best and are interested in your complete satisfaction.

NOTE: This spreader is designed to spread snow and ice control materials only. Do not use it for purposes other than those specified in this manual.

Warranty Registration

Follow the directions on the SnowEx Warranty Registration and Customer Survey form included in the spreader literature kit.

The registration form is also available online at www.snowexproducts.com. Under "Product Info" select "SnowEx Warranty" and click to download the form.

OWNER'S INFORMATION

Owner's Name: _____

Date Purchased: _____

Distributor Name: _____ Phone: _____

Distributor Address: _____

Vehicle Model: _____ Year: _____

Spreader Model: _____ Serial #: _____

Spreader Weight: _____ lb/kg

SAFETY INFORMATION

SAFETY DEFINITIONS

⚠ WARNING

Indicates a potentially hazardous situation that, if not avoided, could result in death or serious personal injury.

⚠ CAUTION

Indicates a potentially hazardous situation that, if not avoided, may result in minor or moderate injury. It may also be used to alert against unsafe practices.

NOTE: Indicates a situation or action that can lead to damage to your spreader and vehicle or other property. Other useful information can also be described.

WARNING/CAUTION LABELS

Please become familiar with the Warning and Caution labels on the spreader.

NOTE: If labels are missing or cannot be read, see your sales outlet.

SP-1875 spreader only

⚠ WARNING

- Never swing spreader with material in hopper.
- Be sure latches are secure before operating vehicle.

D6193

⚠ WARNING

- Keep hands, feet & loose clothing away from moving parts.
- Disconnect power before servicing equipment.

D6192



⚠ WARNING

ROTATING AUGER CAN CAUSE SERIOUS INJURY OR DEATH

- Keep arms, hands, and loose clothing away from auger.
- Shut off control and unplug spreader before servicing.

D6335

⚠ WARNING

- Read owners manual before operating equipment.
- Never remove spreader with material in hopper.

D6194

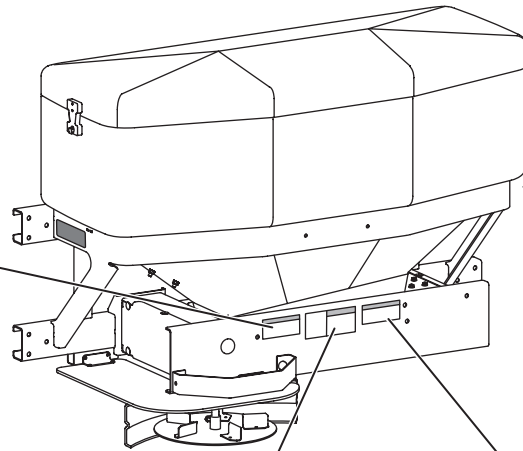

SAFETY INFORMATION

SERIAL NUMBER LABEL

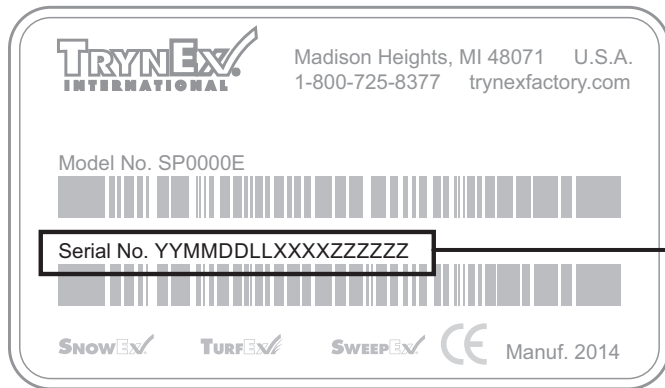
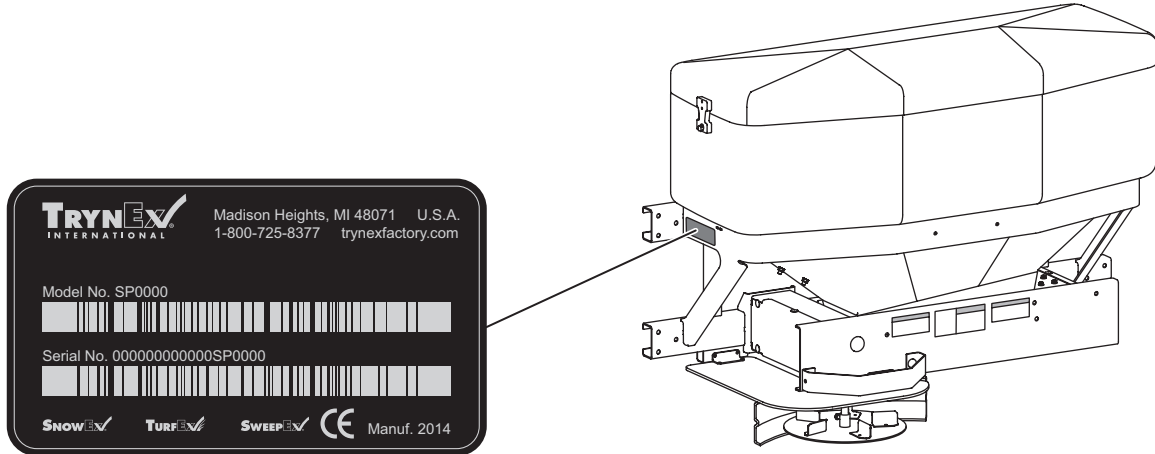

Code	Definition
YY	2-Digit Year
MM	2-Digit Month
DD	2-Digit Day
LL	2-Digit Location Code
XXXX	4-Digit Sequential Number
ZZZZZZ	Assembly Part Number

SAFETY INFORMATION

SAFETY PRECAUTIONS

Improper installation and operation could cause personal injury and/or equipment and property damage. Read and understand labels and this Owner's Manual before installing, operating or making adjustments.

⚠ WARNING

- Driver to keep bystanders minimum of 25 feet away from operating spreader.
- Before working with the spreader, secure all loose-fitting clothing and unrestrained hair.
- Before operating the spreader, verify that all safety guards are in place.
- Before servicing the spreader, wait for auger and spinner to stop.
- Do not climb into or ride on spreader.

⚠ WARNING



Overloading could result in an accident or damage. Do not exceed GVWR or GAWR ratings as found on the driver-side vehicle door cornerpost. See Loading section to determine maximum volumes of spreading material.

⚠ WARNING

Do not install the control for this product in the deployment path of an air bag. Refer to vehicle manufacturer's manual for air bag deployment area(s).

⚠ CAUTION

During the hopper spreader installation we recommend the addition of an OSHA compliant Backup Alarm. This alarm is required for OSHA governed employers.

⚠ CAUTION

If rear directional, CHMSL light or brake stoplights are obstructed by the spreader, the lights shall be relocated, or auxiliary directional or brake stoplights shall be installed.

⚠ CAUTION

- Do not operate a spreader in need of maintenance.
- Before operating the spreader, reassemble any parts or hardware removed for cleaning or adjusting.
- Before operating the spreader, remove materials such as cleaning rags, brushes, and hand tools from the spreader.
- While operating the spreader, use auxiliary warning lights, except when prohibited by law.

⚠ CAUTION

Disconnect electric and/or hydraulic power and tag out if required before servicing or performing maintenance.

⚠ CAUTION



DO NOT leave unused material in hopper. Material can freeze or solidify, causing unit to not work properly. Empty and clean after each use.

NOTE: Lubricate grease fittings after each use. Use a good quality multipurpose grease.

PERSONAL SAFETY

- Remove ignition key and put the vehicle in park or in gear to prevent others from starting the vehicle during installation or service.
- Wear only snug-fitting clothing while working on your vehicle or spreader.
- Do not wear jewelry or a necktie, and secure long hair.
- Wear safety goggles to protect your eyes from battery acid, gasoline, dirt and dust.
- Avoid touching hot surfaces such as the engine, radiator, hoses and exhaust pipes.
- Always have a fire extinguisher rated BC handy, for flammable liquids and electrical fires.

SAFETY INFORMATION

FIRE AND EXPLOSION

⚠ WARNING

Gasoline is highly flammable and gasoline vapor is explosive. Never smoke while working on vehicle. Keep all open flames away from gasoline tank and lines. Wipe up any spilled gasoline immediately.

Be careful when using gasoline. Do not use gasoline to clean parts. Store only in approved containers away from sources of heat or flame.

CELL PHONES

A driver's first responsibility is the safe operation of the vehicle. The most important thing you can do to prevent a crash is to avoid distractions and pay attention to the road. Wait until it is safe to operate Mobile Communication Equipment such as cell phones, text messaging devices, pagers or two-way radios.

VENTILATION

⚠ WARNING

Vehicle exhaust contains lethal fumes. Breathing these fumes, even in low concentrations, can cause death. Never operate a vehicle in an enclosed area without venting exhaust to the outside.

BATTERY SAFETY

⚠ CAUTION









Batteries normally produce explosive gases which can cause personal injury. Therefore, do not allow flames, sparks or lit tobacco to come near the battery. When charging or working near a battery, always cover your face and protect your eyes, and also provide ventilation.

- Batteries contain sulfuric acid which burns skin, eyes and clothing.
- Disconnect the battery before removing or replacing any electrical components.

TORQUE CHART

⚠ CAUTION

Read instructions before assembling. Fasteners should be finger tight until instructed to tighten according to the torque chart. Use standard methods and practices when attaching snowplow, including proper personal protective safety equipment.

Recommended Fastener Torque Chart					
Inch Fasteners Grade 5 and Grade 8					
Size	Torque (ft-lb)		Size	Torque (ft-lb)	
	 Grade 5	 Grade 8		 Grade 5	 Grade 8
1/4-20	8.4	11.9	9/16-12	109	154
1/4-28	9.7	13.7	9/16-18	121	171
5/16-18	17.4	24.6	5/8-11	150	212
5/16-24	19.2	27.3	5/8-18	170	240
3/8-16	30.8	43.6	3/4-10	269	376
3/8-24	35.0	49.4	3/4-16	297	420
7/16-14	49.4	69.8	7/8-9	429	606
7/16-20	55.2	77.9	7/8-14	474	669
1/2-13	75.3	106.4	1-8	644	909
1/2-20	85.0	120.0	1-12	704	995
Metric Fasteners Class 8.8 and 10.9					
Size	Torque (ft-lb)		Size	Torque (ft-lb)	
	 Class 8.8	 Class 10.9		 Class 8.8	 Class 10.9
M6 x 1.00	7.7	11.1	M20 x 2.50	325	450
M8 x 1.25	19.5	26.9	M22 x 2.50	428	613
M10 x 1.50	38.5	53.3	M24 x 3.00	562	778
M12 x 1.75	67	93	M27 x 3.00	796	1139
M14 x 2.00	107	148	M30 x 3.50	1117	1545
M16 x 2.00	167	231	M33 x 3.50	1468	2101
M18 x 2.50	222	318	M36 x 4.00	1952	2701
These torque values apply to fasteners except those noted in the instructions.					

LOADING

This Manual covers vehicles that have been recommended for carrying the tailgate spreader. Please see your local dealer for proper vehicle applications.

WARNING

Overloading could result in an accident or damage. Do not exceed GVWR or GAWR as found on the driver-side cornerpost of vehicle.



CAUTION

Read and adhere to manufacturer's ice-control material package labeling, including Material Safety Data Sheet requirements.

CERTIFICATION

WARNING

New untitled vehicle installation of a spreader requires National Highway Traffic Safety Administration altered vehicle certification labeling. Installer to verify that struck load of snow or ice control material does not exceed GVWR or GAWR rating label and complies with FMVSS.

LOADING

DETERMINING VEHICLE PAYLOAD

⚠ WARNING

Overloading could result in an accident or damage. Do not exceed GVWR or GAWR ratings as found on the driver-side door cornerpost of the vehicle. See Loading Section to determine maximum volumes of spreading material.

1. Install the tailgate spreader and optional equipment according to the instructions.
2. Install or attach any other equipment that will be on the vehicle while the tailgate spreader will be in use (step bumper, trailer hitch, snowplows, etc.). Fill gas tanks.
3. Obtain the Gross Vehicle Weight Rating (GVWR), Front Gross Axle Weight Rating (FGAWR) and Rear Gross Axle Weight Rating (RGAWR) from the certification label located inside the driver-side door jamb or door.
4. With the occupants in the truck for normal tailgate spreader operation, weigh the vehicle to obtain gross vehicle weight (GVW).
5. Subtract the GVW from the GVWR to determine the available material payload.
6. Obtain the weight per cubic foot (lb/cu ft) of the desired material. Divide the weight into the payload to determine the maximum volume of material that can be carried.
7. Compare the maximum volume to determine the maximum height of the material in the tailgate spreader.
8. Fill the hopper with the material to the calculated height. Reweigh the vehicle with occupants and verify the GVW, Front Gross Axle Weight and Rear Gross Axle Weight are less than the vehicle's ratings.
9. Repeat Steps 6 through 8 for each type of material.

APPROXIMATE MATERIAL WEIGHTS

Material	Density (lb/ft ³)
Rock Salt (Dry)	80–90
Sand/Salt Mix (Dry)	95–120
A 1:1 ratio is recommended for salt/sand mix to prevent material from freezing.	

Weight of spreader and mount must be added to struck material weight to determine total spreader weight.

⚠ WARNING

Do not overload vehicle. Use chart below to calculate weight of material. Weights of material are an average for dry materials.

⚠ CAUTION

Never use wet materials or materials with foreign debris with any of these spreaders. These units are designed to handle dry, clean, free flowing material.

MOUNTING THE SPREADER

⚠ WARNING

Spreader shall be bolted to vehicle frame.
Do not rely on the tie-down chains or straps
alone to hold spreader in vehicle.

⚠ CAUTION

Before lifting, verify that the hopper is empty
of material. The lifting device must be able to
support the spreader's weight as shown in
the spreader specifications table.

NOTE: Periodically throughout the snow and ice
control season, verify that mounting devices
are secure.

MODEL SP-1875

Mounts are sold separately for the SP-1875 model.
Refer to the instructions packed with the selected
mount.

MODEL SP-1575

The model SP-1575 spreader ships from the factory
with the hitch set up in the 3-point mount
position.

To switch the spreader to the truck mount position,
remove the hitch, rotate it 180° as shown below,
and reinstall it.

**3-POINT MOUNT
POSITION**

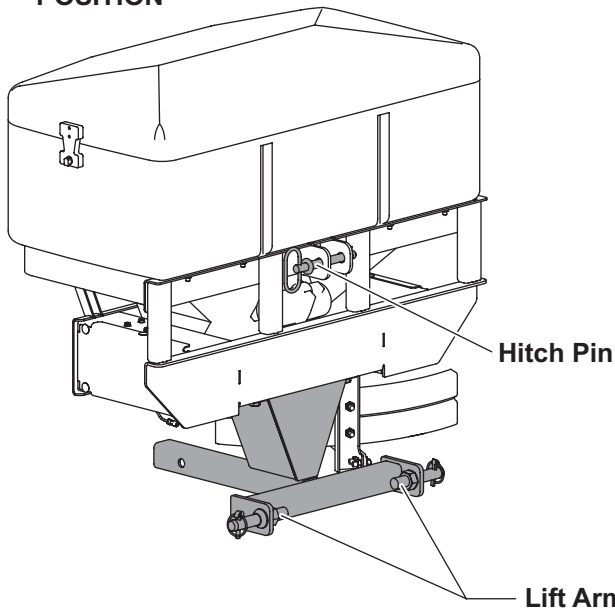

**TRUCK MOUNT
POSITION**

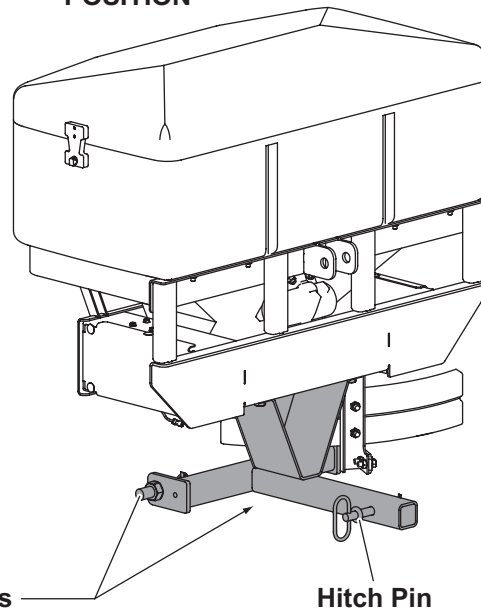

MOUNTING THE SPREADER

Always use the longer (1-1/2") cap screw and washer to attach the corner of the hitch that fits behind the tab of the material chute.

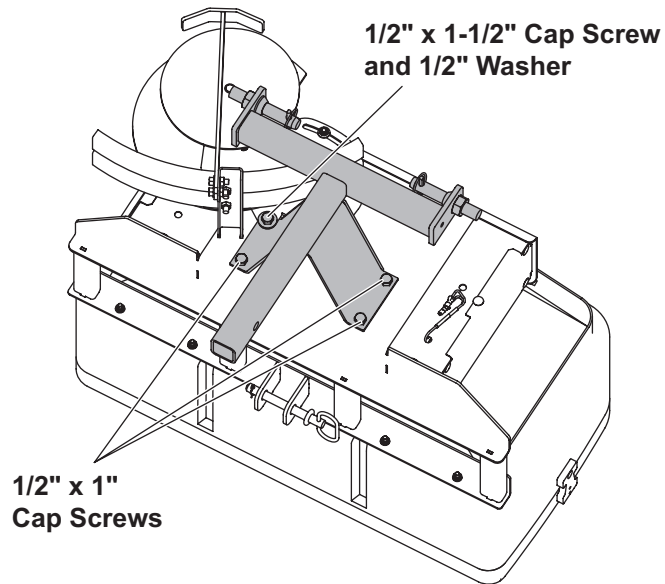

LICENSE PLATE INSTALLATION (IF REQUIRED)

Install the license plate to the mounting holes in the frame using two 1/4" x 1/2" machine screws and two 1/4" locknuts.

License Plate Mounting Holes

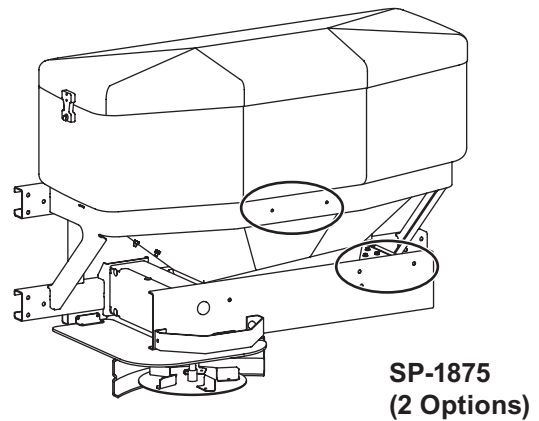
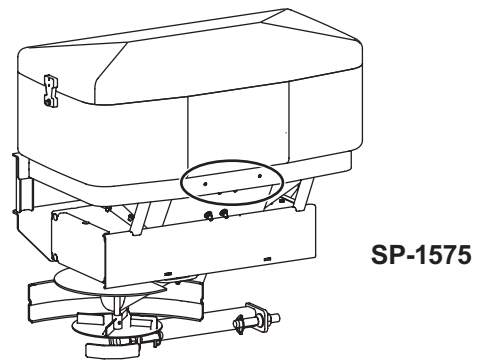

ELECTRICAL HARNESS INSTALLATION

1. Route the vehicle harness along the vehicle frame. Do not route it close to the exhaust system or engine, where extreme heat could melt the wiring insulation and short out the spreader and vehicle electrical systems.

Attach the harness to frame holes and frame supports. Do not attach to fuel or brake lines. Use heavy-duty cable ties or frame clips to fasten the harness along the frame, and lighter-duty cable ties everywhere else

2. Mount the rear plug on the vehicle bumper using supplied fasteners. Locate the plug toward the center of the bumper, away from the path of debris thrown by the tires.

NOTE: Apply a small amount of dielectric grease to the plug. Try to mount the plug facing upward to help keep plugs tightly sealed.

3. Lay out the control power cable along the fire wall and fender well. Do not connect the power leads to the battery yet.
4. Drill a new 3/4" hole through the fire wall — or use an existing access hole — to route the control power cable and harness into the vehicle cab.

⚠ CAUTION

Before drilling holes, check to be sure that no vehicle wiring or other components could be damaged.

Check the area on the other side of the fire wall to make sure you will not be drilling into the vehicle harness or a control module. Generally, either side of the steering wheel offers a good location.

⚠ CAUTION

Do not alter, modify or install additional components in shaded areas shown below. Failure to comply may interfere with airbag deployment or cause injury to operator in an accident.

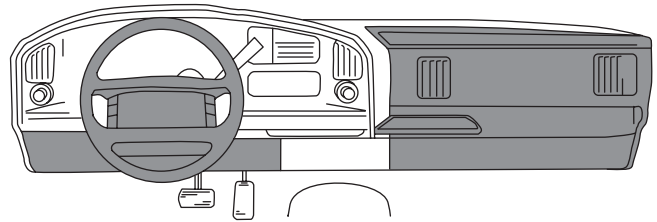

5. Connect the harness and the control power cable to the back of the control and mount the control in a suitable location within easy reach of the vehicle operator without restricting access to the vehicle controls and instrumentation.

Do not mount the control close to any heater vents or in areas prohibited by the vehicle manufacturer for crashworthiness. See the vehicle's body builder's book, owner's manual or service manual for details.

NOTE: You may want to contact the customer before mounting the control. Some prefer not to have holes drilled into the dashboard.

ELECTRICAL HARNESS INSTALLATION

6. Connect the power cable leads to the battery: Red POSITIVE (+), Black NEGATIVE (-). If using a dual battery system, always connect to the primary battery.
7. Secure loose loom to any other large or medium vehicle harness using medium-duty cable ties.
8. Toggle the control POWER switch ON and OFF to check for power. Once power has been confirmed, turn the control OFF.

NOTE: Use dielectric grease on all electrical connections.

NOTE: Do not modify harness length. Any modifications will void the warranty.

- Read lead labels before attaching to power source or ground.
- No other devices may be spliced into the wiring harness.
- Any repairs to the wiring harness must be done with heat-shrink butt connectors.
- If adding an in-line fuse, use a 60-amp maxi fuse or circuit breaker.

NOTE: In the off season, remove the control and put it in a cool, dry place. Vehicle interior summer temperatures could damage the circuit board and void the warranty.

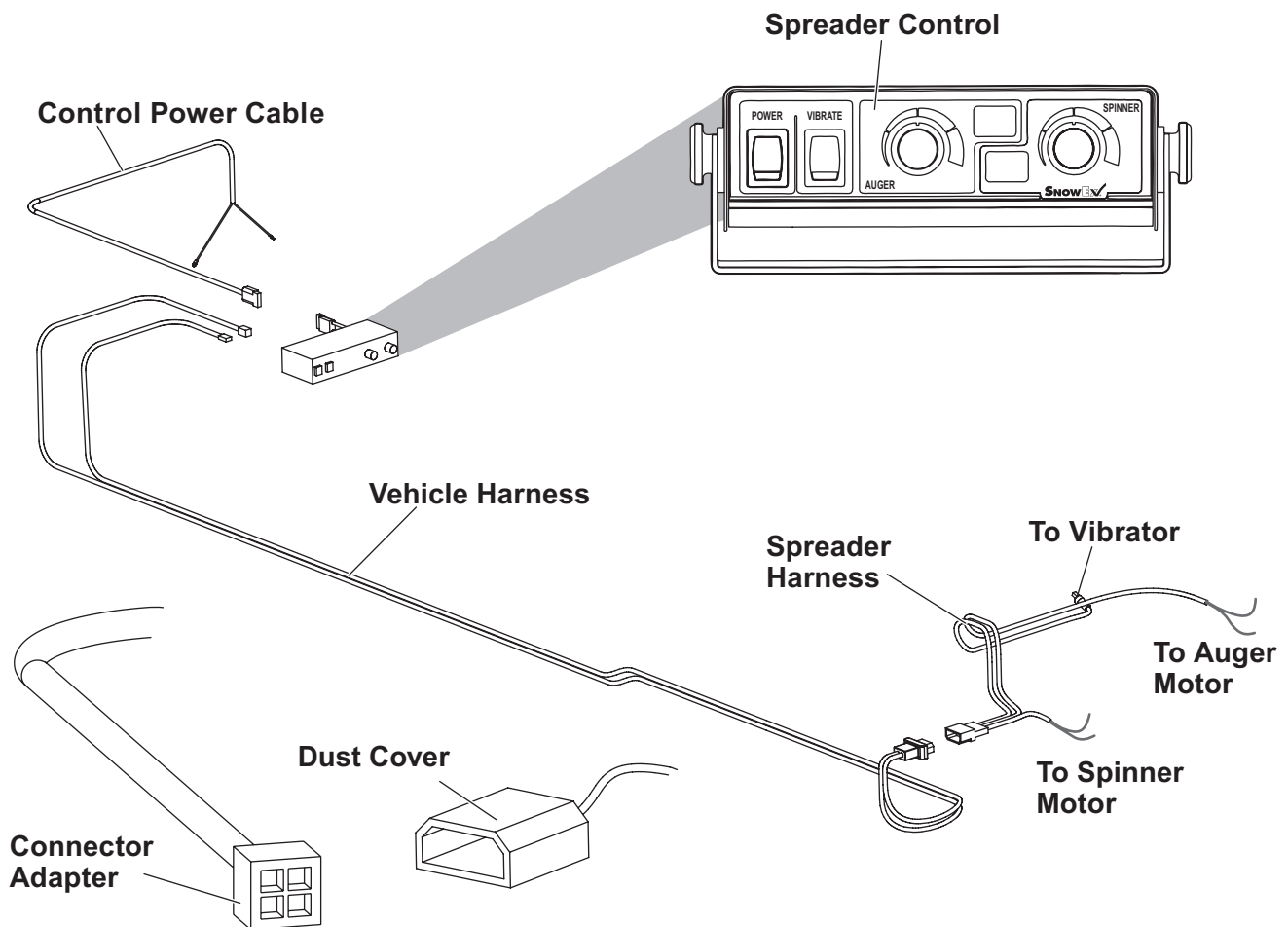

HARNESS & CONTROL DIAGRAMS

VEHICLE HARNESS

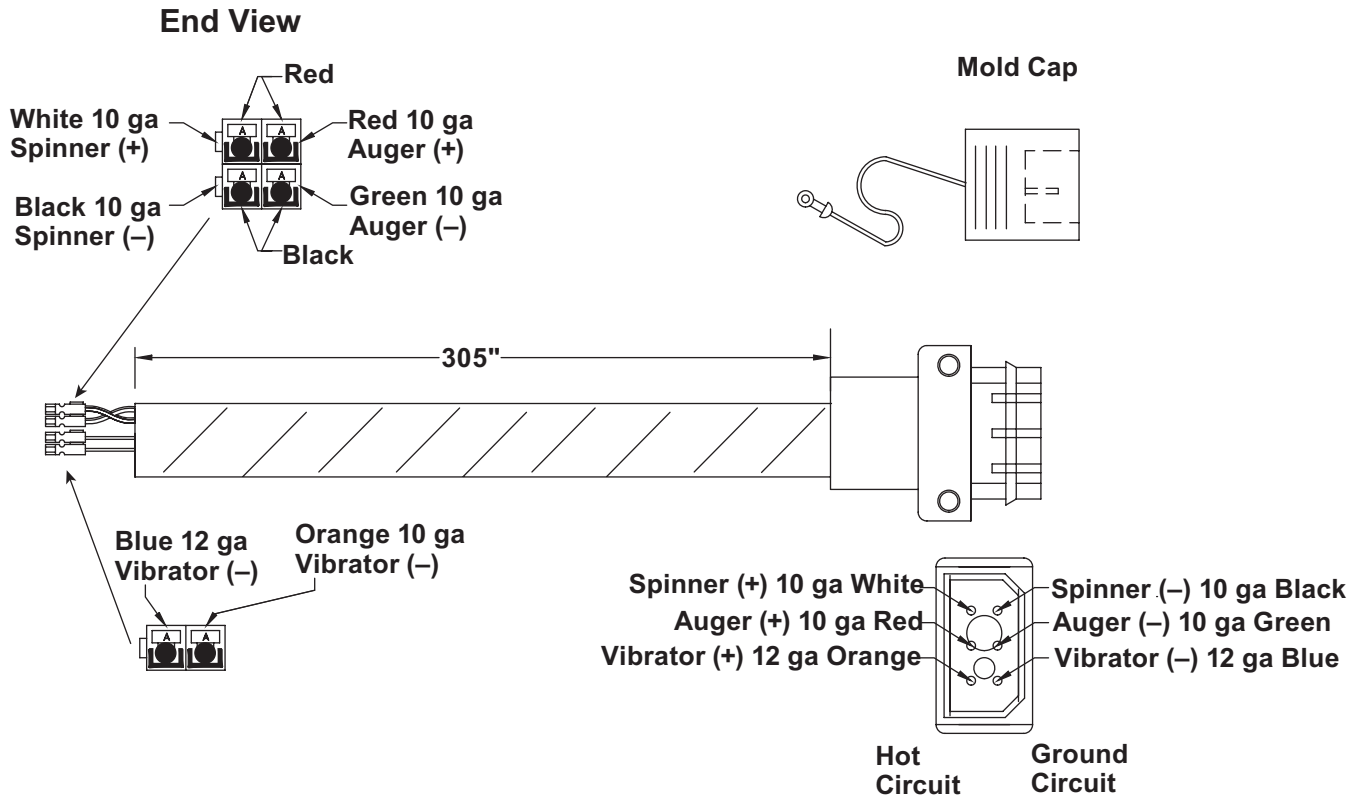

CONTROL POWER CABLE

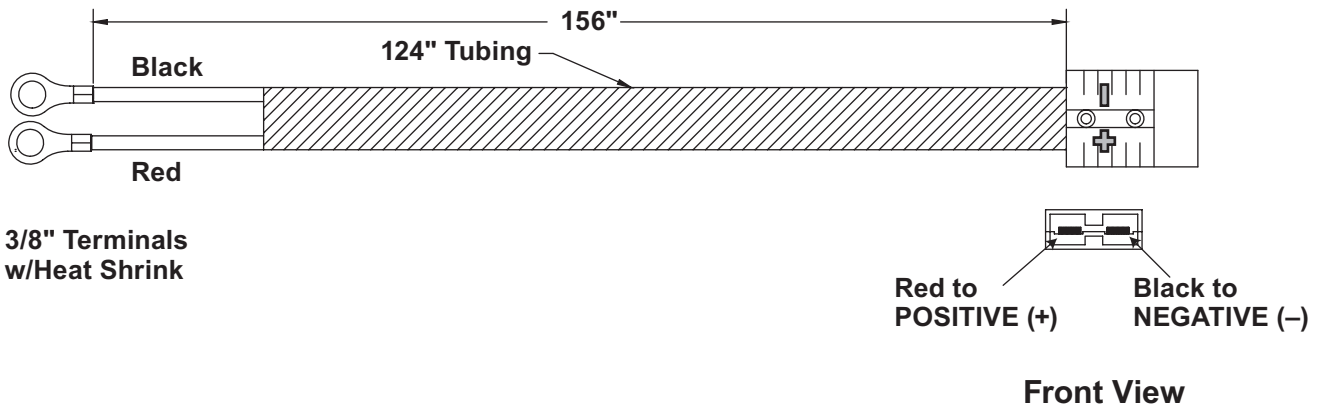

HARNESS & CONTROL DIAGRAMS

SPREADER HARNESS

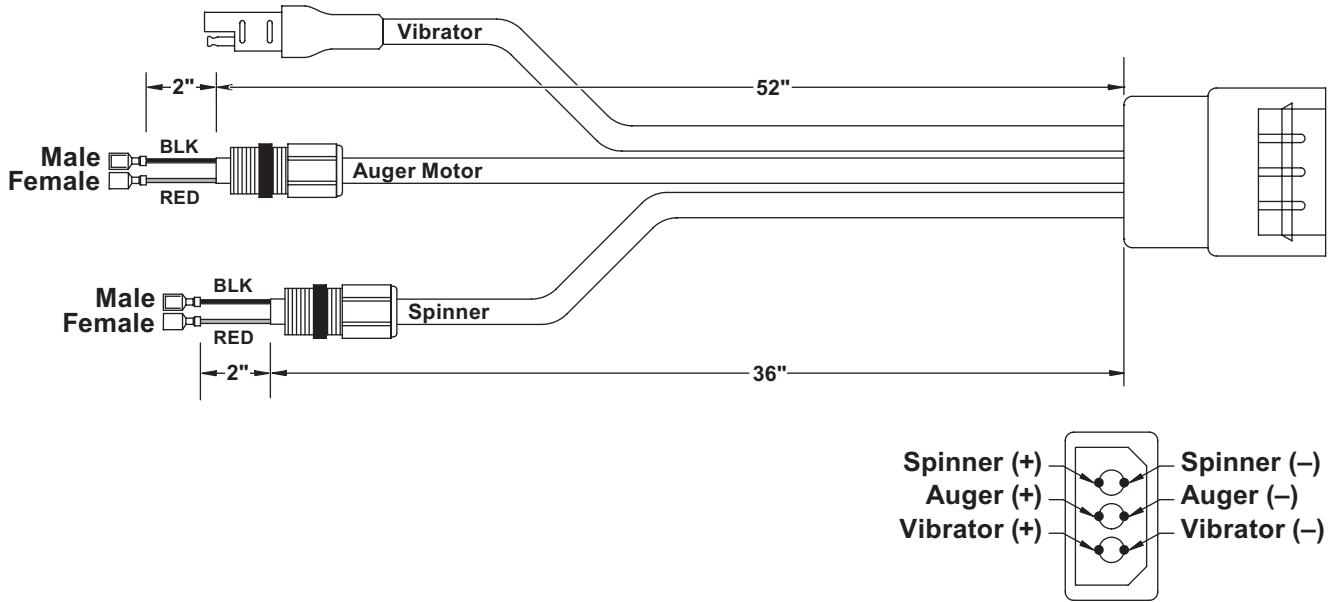

CONTROL

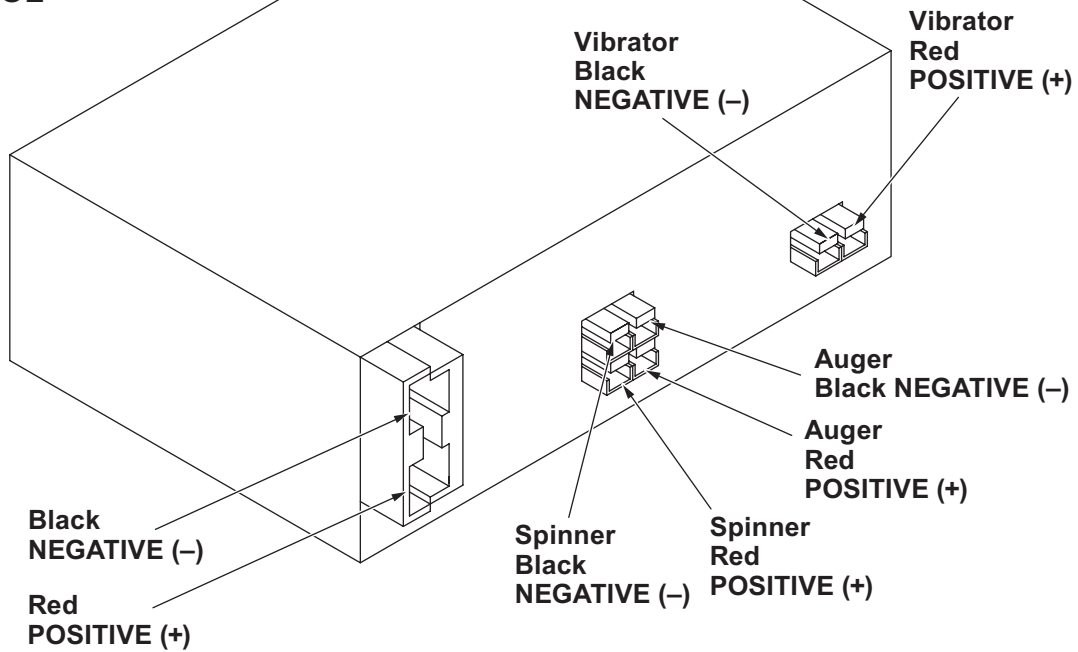

OPERATING THE SPREADER

⚠ WARNING

Never operate equipment when under the influence of alcohol, drugs, or medications that might alter your judgment and/or reaction time.

⚠ WARNING

Never exceed 45 mph (72 km/h) when loaded spreader is attached to vehicle. Braking distances may be increased and handling characteristics may be impaired at speeds above 45 mph (72 km/h).

⚠ WARNING

Never allow children to operate or climb on equipment.

CAB CONTROL

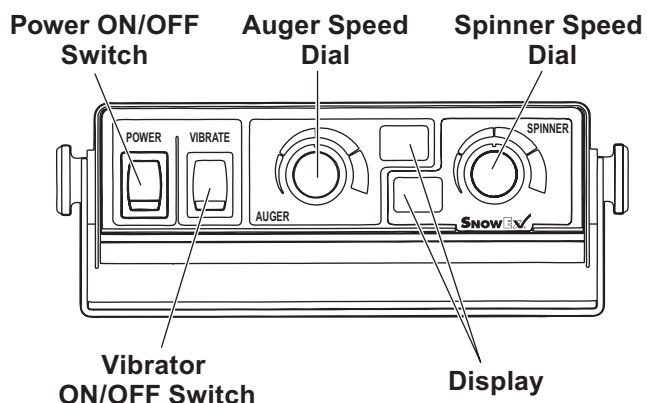

Starting and Stopping the Motor

⚠ WARNING

Before starting the spreader, the driver shall verify that all bystanders are a minimum of 25 feet away from operating spreader.

To start the spreader, press the control POWER switch to the ON position.

Press the POWER switch to the OFF position to stop the spreader.

NOTE: The truck ignition must be ON to start the spreader.

NOTE: If truck ignition is turned OFF while spreader is running, the motors will stop.

Adjusting Auger/Spinner Speed

Speed of auger and spinner can be adjusted separately to get desired flow and spread distance.

Turn the speed dial clockwise to increase speed. When the POWER switch is set to the ON position, the spreader will accelerate to the speed set on the dial.

Turn the speed dial counterclockwise to decrease speed.

OPERATING THE SPREADER

Auto-Reverse (AR) Feature

If your control displays "OL," this could indicate a jammed auger. Running the auto reverse (AR) function can often clear the jam.

1. Press the POWER switch to the OFF position and leave the control OFF for 3 seconds.
2. Press the POWER switch to the ON position.

When the machine restarts, the AR sequence will begin automatically, and the auger will reverse for several rotations to clear the jam. After a pause of several moments, the auger will automatically return to normal rotation.

3. If the jam was not cleared, the control will again display "OL." You may repeat Steps 1 & 2 for a second and third time.

⚠ CAUTION

Disconnect electric power and tag out if required before servicing or performing maintenance.

4. If, after the third try, the control still displays "OL," you must extract the material that is causing the problem.

Follow all warning directions when clearing jams.

Vibrator Function

A heavy-duty vibrator is standard equipment on the Model SP-1575 and SP-1875 spreaders. Turn the vibrator ON as needed to keep dense material flowing and prevent bridging of material in the hopper.

Alarm Codes

If the control emits beeping sounds, check the display for problem codes and follow the instructions given in the Troubleshooting section of this manual.

Refer to the Troubleshooting section if any problems occur while operating the spreader.

CONTROLLING FLOW OF MATERIAL

The factory installed material baffle in the spreader stops fine materials from free flowing. When dense or damp material is being spread, or when more flow is desired, remove the material baffle. However, it is recommended that the baffle remain in place when spreading bulk salt.

The inverted vee in the SP-1875 spreader should not be removed except when servicing the spreader.

The Material Control Tube optional accessory prevents leaking issues when handling fine pellet and flake materials.

SPREADING TIPS

- Spread ice melters with the storm to prevent unmanageable levels of ice.
- Never exceed 10 mph (16 km/h) when spreading.
- For a wider pass, increase spinner speed.
- For a heavier pass, drive slower or increase auger speed.
- Never operate spreader near pedestrians.
- Calculate spread pattern when near vegetation.

NOTE: The spinner motor is not designed for continuous duty. Allow the motor to cool between long cycle times.

MAINTENANCE

WARNING

Never remove the spreader with material in the hopper.

CAUTION

Disconnect electric power at spreader electrical wiring harness connection and tag out if required before servicing or performing maintenance.

CAUTION

- When replacing parts use only original manufacturer's parts. Failure to do so will void warranty.
- The control is a solid-state electronic unit and is not serviceable. Any attempt to service will void warranty.
- There are no serviceable parts in the motor/transmission assembly. Any attempt to service will void warranty.
- When pressure washing motor enclosure area, stay at least 36" away from motor enclosures.

LUBRICATION

To keep your spreader running smoothly, observe the following recommendations:

- Lubricate bearings after every 20 hours of use.
- Apply a small amount of light oil to latches as needed.
- For SP-1875 spreader installations using the pivot mount, keep the pivot assembly well greased to prevent corrosion.

AFTER EACH USE

CAUTION



DO NOT leave unused material in hopper. Material can freeze or solidify, causing unit to not work properly. Empty and clean after each use.

- Wash out the hopper and rinse off all external surfaces.
- Apply dielectric grease on all electrical connections to prevent corrosion.

AT THE END OF EACH SEASON OR AFTER EXTENDED STORAGE

- Wash out the hopper and rinse off all external surfaces.
- Apply dielectric grease on all electrical connections to prevent corrosion.
- Lubricate all grease fittings with good quality multipurpose grease.
- Oil or paint all bare metal surfaces.
- If motor cover is removed for any reason, use silicone sealant to ensure weather proofing of enclosure.

STORAGE

Store the spreader in a clean, dry location and away from direct sunlight.

NOTE: In the off season, remove the control and put it in a cool, dry place. Vehicle interior summer temperatures could damage the circuit board and void the warranty.

TROUBLESHOOTING

Please see your SnowEx distributor for service. The troubleshooting reference table below and the diagrams on the following pages may also guide you in diagnosing the issue.

Before servicing the spreader:

- Review all safety information.
- Confirm that all electrical connections are tight and clean.
- Confirm that nothing is jammed in the hopper.

ISSUE	POSSIBLE CAUSE	POSSIBLE SOLUTION
Motor doesn't run.	Loose electrical connections	Check all connections.
	Blown fuse	Replace fuse.
	Motor seized	Replace motor.
Control shuts down.	Jammed auger	Carefully clear jammed material.
	Poor electrical conditions	Clean or replace connectors. Apply dielectric grease.
	Electrical short	Check electrical connections. Check for bare wires.
	Control failure	Replace control.
Material does not flow from hopper.	Empty hopper	Fill hopper.
	Wet material	Replace with dry material.
	Frozen or coarse material	Replace material.
	Spinner not turning	Check connection inside motor enclosure.
	Auger loose on shaft	Align auger with flat machined area on shaft and tighten locking bolt on side of auger.
	Vibrator not working	Check electrical connection; if connection is confirmed, replace vibrator.
Alarm beeps, display shows "OL" or "OH."	Jammed auger, overload shutdown	Turn spreader OFF for 3 seconds, then restart. If alarm continues, turn spreader OFF and clear lumps and debris from around auger.
Alarm beeps, display shows "E1."	System short	Turn spreader OFF. Do not use spreader until problem is corrected.
Alarm beeps, display shows "EO."	No power to motor	Turn spreader OFF. Check all electrical connections.
Alarm beeps, display shows "LB."	Vehicle battery is extremely low; poor battery connection.	Turn spreader OFF. Check battery connection. Charge vehicle battery.

TROUBLESHOOTING

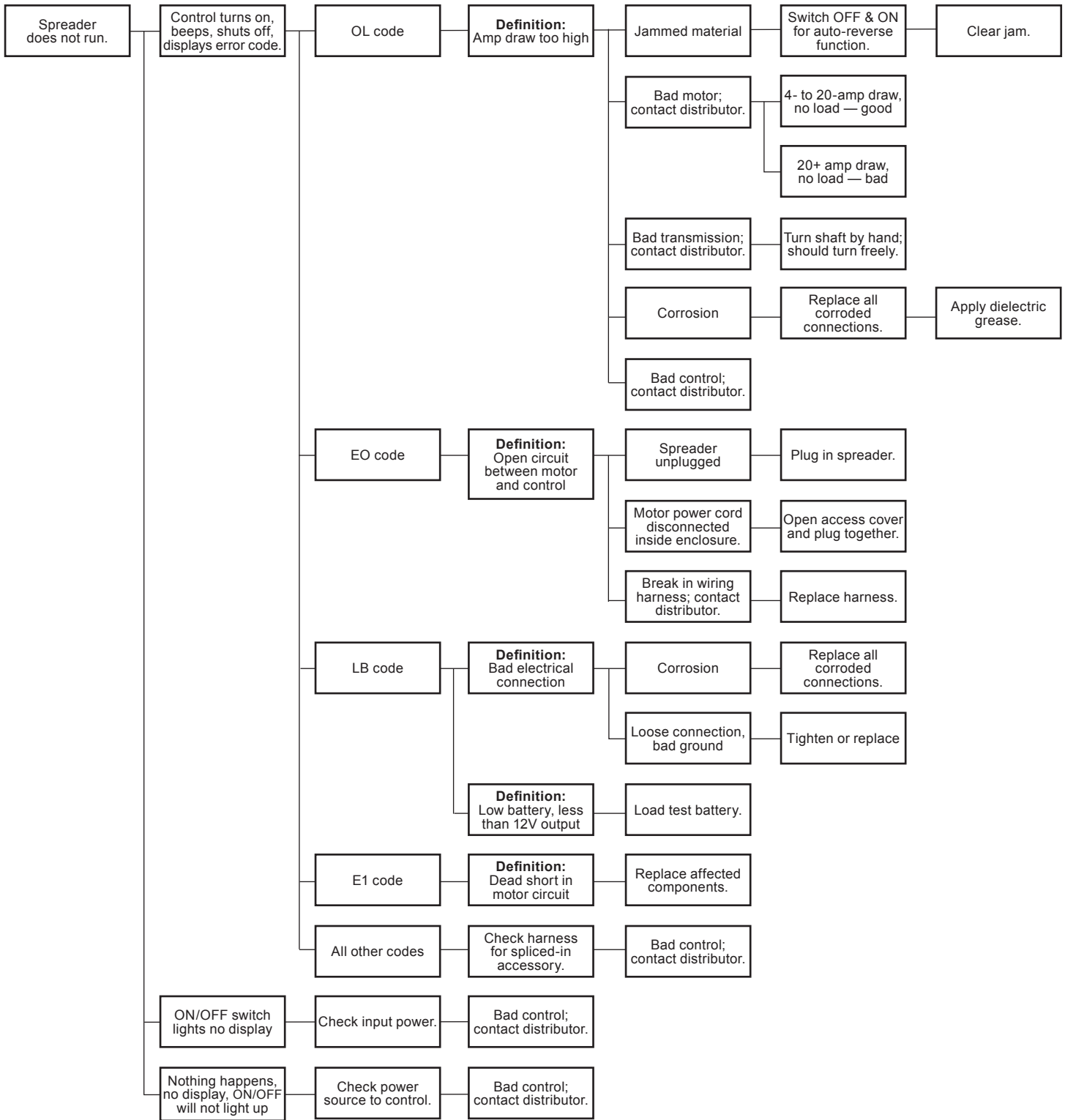

TROUBLESHOOTING

Material Flow Troubleshooting

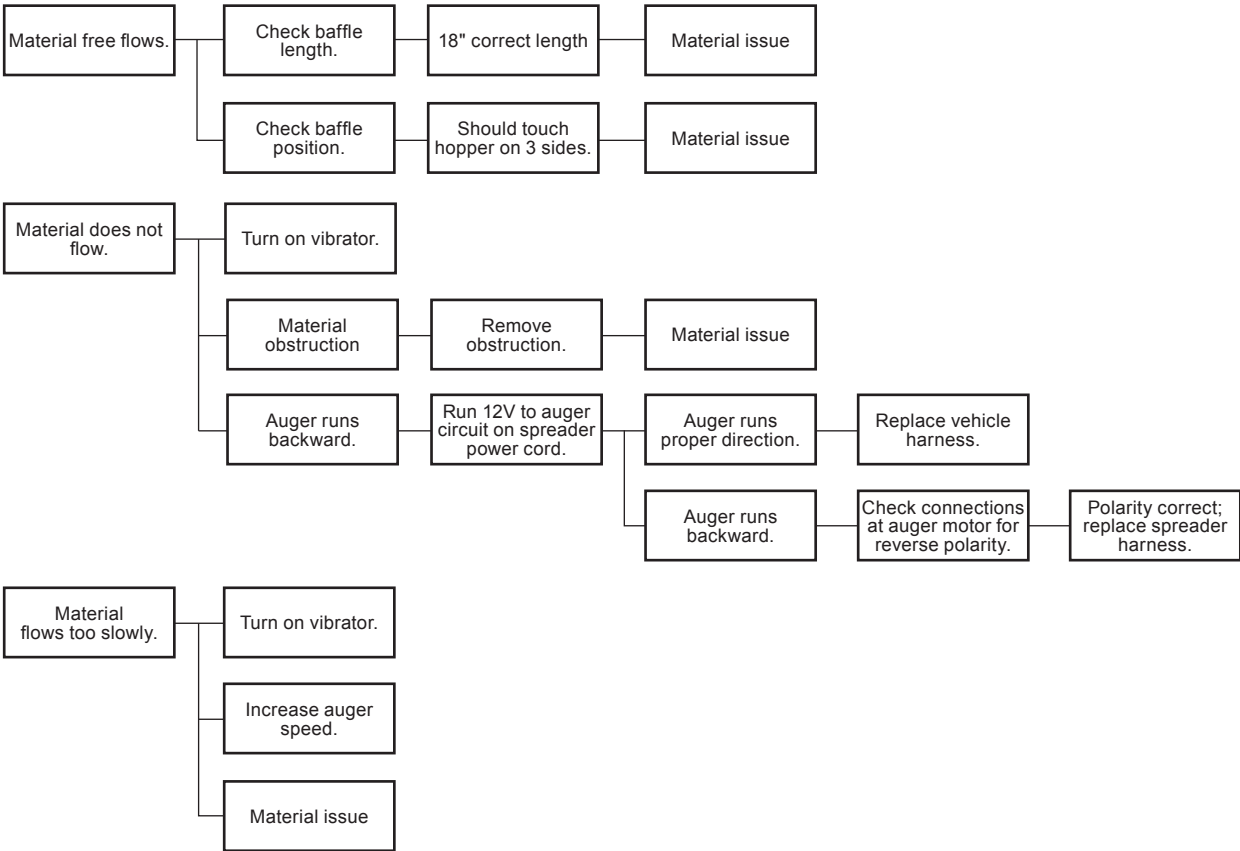



531 Ajax Drive
Madison Heights, MI 48071-2429
www.snowexproducts.com

 A DIVISION OF DOUGLAS DYNAMICS, LLC

TrynEx International reserves the right under its product improvement policy to change construction or design details and furnish equipment when so altered without reference to illustrations or specifications used. TrynEx International or the vehicle manufacturer may require or recommend optional equipment for spreaders. Do not exceed vehicle ratings with a spreader. TrynEx International offers a limited warranty for all spreaders and accessories. See separately printed page for this important information. The following are registered (®) or unregistered (™) trademarks of Douglas Dynamics, LLC: SnowEx®, TrynEx®.

Printed in U.S.A.