

OPERATION MANUAL

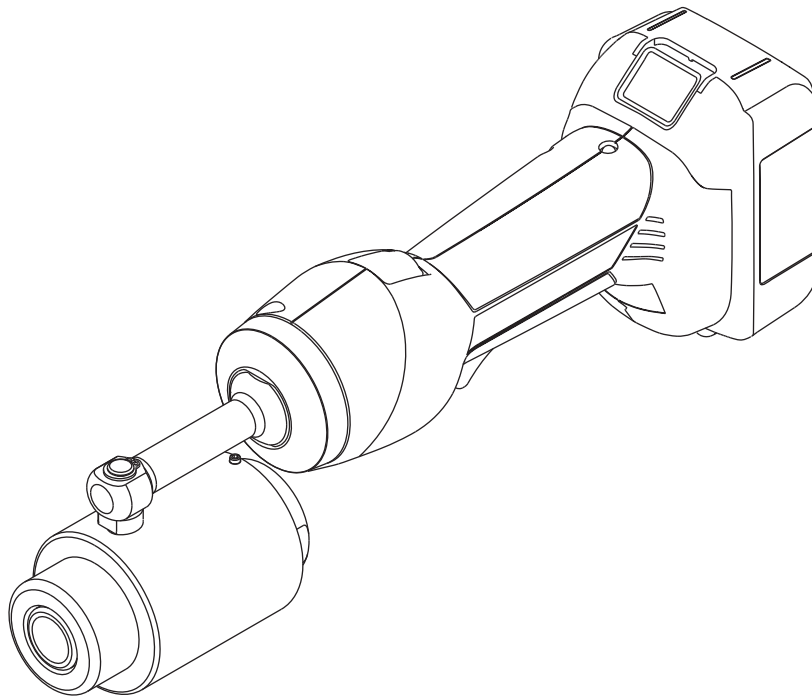

Serial Number



GATOR[®] LS100L

Battery-powered Punch Driver



Read and understand all of the instructions and safety information in this manual before operating or servicing this tool.

Register this product at www.greenlee.com

Table of Contents

Description	2
Safety	2
Purpose of this Manual	2
Important Safety Information	3–5
Identification	6
Specifications	6
Setup and Operation	7–11
Capacity and Draw Stud Selection Guide.....	12
Maintenance.....	13
Troubleshooting.....	14

Description

The Greenlee LS100L Battery-powered Punch Driver is a hand-held, self-contained punch driver intended to be used with Greenlee punches, dies, and draw studs for punching holes through plastic, fiberglass, aluminum, and steel.

The LS100L is designed to be used with the following Greenlee accessories:

- Standard punches, dies, and draw studs
- Slug-Buster® punches, dies, and draw studs
- Slug-Splitter® punches, dies, and draw studs
- SPEED PUNCH® Knockout System
- Electronic connector panel punches
- Special shape punches, dies, and draw studs (“D”, Double “D”, Key, Square, Rectangular, and Oiltight with notches)

Standard, Slug-Buster, Electronic Connector Panel Punches, and special shape punches can punch holes through plastic, fiberglass, aluminum, and steel. Slug-Splitter punches, dies, and draw studs are capable of punching through all of these materials as well as stainless steel. Refer to the “Capacity and Draw Stud Selection Guide” in this manual for detailed information on punch sizes and maximum material thickness. Do not exceed the capacity of the punch.

This tool is protected by U.S. Patent No. 6,276,186, 6,401,515, 7,086,979, and 7,254,982.

Safety

Safety is essential in the use and maintenance of Greenlee tools and equipment. This manual and any markings on the tool provide information for avoiding hazards and unsafe practices related to the use of this tool. Observe all of the safety information provided.

Purpose of this Manual

This manual is intended to familiarize all personnel with the safe operation and maintenance procedures for the following Greenlee tool:

LS100L Battery-powered Punch Driver

Keep this manual available to all personnel.

Replacement manuals are available upon request at no charge at www.greenlee.com.

All specifications are nominal and may change as design improvements occur. Greenlee Textron Inc. shall not be liable for damages resulting from misapplication or misuse of its products.

GATOR, Kwik-Stepper, Slug-Buster, Slug-Splitter, and SPEED PUNCH are registered trademarks of Textron Innovations Inc.



Do not discard this product or throw away!

For recycling information, go to www.greenlee.com.

KEEP THIS MANUAL

IMPORTANT SAFETY INFORMATION



SAFETY ALERT SYMBOL

This symbol is used to call your attention to hazards or unsafe practices which could result in an injury or property damage. The signal word, defined below, indicates the severity of the hazard. The message after the signal word provides information for preventing or avoiding the hazard.

⚠️ DANGER

Immediate hazards which, if not avoided, **WILL** result in severe injury or death.

⚠️ WARNING

Hazards which, if not avoided, **COULD** result in severe injury or death.

⚠️ CAUTION

Hazards or unsafe practices which, if not avoided, **MAY** result in injury or property damage.

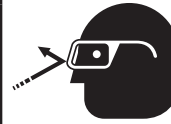

⚠️ WARNING

Wear eye protection when operating or servicing this tool.

Failure to wear eye protection could result in serious eye injury from flying debris or hydraulic oil.



⚠️ WARNING

Skin injection hazard:

Do not use hands to check for oil leaks. Oil under pressure easily punctures skin. If injured, seek medical attention immediately to remove oil.

Failure to observe this warning could result in serious injury, gangrene, or death.



⚠️ WARNING

Do not use solvents or flammable liquids to clean the tool body. Solvents or flammable liquids could ignite and cause serious injury or property damage.



⚠️ WARNING

Read and understand all of the instructions and safety information in this manual before operating or servicing this tool.

Failure to observe this warning could result in severe injury or death.



⚠️ WARNING

Electric shock hazard:

This tool is not insulated. When using this unit on or near energized electrical lines, use proper personal protective equipment.

Failure to observe this warning could result in severe injury or death.



⚠️ WARNING

Pinch points:

- Remove battery before changing dies, adapters, or jaws.
- Keep hands away from the tool head when punching.

Failure to observe these warnings could result in severe injury or death.

IMPORTANT SAFETY INFORMATION

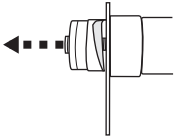
	<p style="text-align: center;">⚠ WARNING</p> <p>A component failure could throw broken parts.</p> <ul style="list-style-type: none"> • Do not allow anyone to stand in front of the punch or behind the hydraulic ram. • Close access doors or covers on any equipment that is in line with the punch or ram. <p>Failure to observe this warning could result in severe injury or death.</p>
---	---

<p style="text-align: center;">⚠ WARNING</p> <ul style="list-style-type: none"> • Inspect tool for wear or damage. Replace any worn, damaged, or missing components with Greenlee replacement parts. A damaged or improperly assembled tool can break and strike nearby personnel with sufficient force to cause severe injury or death. • Inspect the punch, die, draw stud, and spacers for wear or damage. Replace any worn or damaged items with Greenlee replacement parts. Replace any punches that have dull cutting surfaces.
--

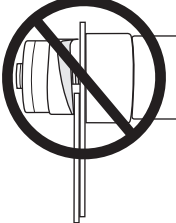
	<p style="text-align: center;">⚠ WARNING</p> <p>Do not attempt to punch a hole through two or more layers of material. This will bend or break the draw stud, and could throw parts with great force.</p> <p>Failure to observe this warning could result in severe injury or death.</p>
--	---

<p style="text-align: center;">⚠ WARNING</p> <p>Do not exceed the rated capacity of this tool. Exceeding the rated capacity could cause a component failure, which could throw broken parts with great force.</p> <p>Failure to observe this warning could result in severe injury or death.</p>

<p style="text-align: center;">⚠ WARNING</p> <p>Set up the tool properly. An improper setup could cause a component to fail and strike nearby personnel with great force.</p> <ul style="list-style-type: none"> • Use only Greenlee punches, dies, and draw studs. Other manufacturers' components might not withstand the forces generated by this punch driver. • Manual Punch Setup: The punch must be threaded completely onto the draw stud. All of the punch threads must be engaged by the draw stud threads. Incomplete assembly could cause a component failure. • Hydraulic Punch Setup: The draw stud must be threaded completely into the driver head. The punch must be threaded completely onto the draw stud. All of the punch threads must be engaged by the draw stud threads. Incomplete assembly could cause a component failure. • SPEED PUNCH Setup: The draw stud must be threaded completely into the driver head. The SPEED LOCK must fully engage and completely close on the draw stud. Incomplete assembly could cause a component failure. <p>Failure to observe these warnings could result in severe injury or death.</p>

<p style="text-align: center;">⚠ WARNING</p> <p>Do not dispose of batteries in a fire. They will vent fumes and may explode.</p> <p>Failure to observe this warning could result in severe injury from harmful fumes or burns from flying debris.</p>
--

IMPORTANT SAFETY INFORMATION

⚠ CAUTION

- Do not use this tool for continuous use. After 30 to 40 cycles, allow the tool to cool for 15 minutes.
- Do not secure this tool in a vise. This tool is designed for hand-held operation.
- This tool may be used in damp or wet environments; however, air-drying is recommended before use if the tool becomes soaked. Damage may result when the tool is operated prior to thorough drying when electrical components are soaked.
- Use this tool for the manufacturer's intended purpose only.

Failure to observe these precautions may result in injury or property damage.

⚠ CAUTION

Do not allow anything to contact the battery terminals.

- Do not immerse the batteries in liquid. Liquid may create a short circuit and damage the battery. If batteries are immersed, contact your service center for proper handling.
- Do not place the battery into a pocket, tool pouch, or tool box with conductive objects. Conductive objects may create a short circuit and damage the battery.
- Do not place a battery on moist ground or grass. Moisture may create a short circuit and damage the battery.

Failure to observe these precautions may result in injury or property damage.

⚠ CAUTION

- Do not store the battery at more than 122 °F (50 °C) or less than -4 °F (-20 °C). Damage to the battery can result.
- Do not use another manufacturer's charger. Other manufacturers' chargers may overcharge and damage the battery.
- Do not attempt to open the battery. It contains no user-serviceable parts.

Failure to observe these precautions may result in injury or property damage.

⚠ CAUTION

Do not perform any service or maintenance other than as described in this manual. Injury or damage to the tool may result.

Failure to observe this precaution may result in injury and property damage.

Note: Keep all decals clean and legible, and replace when necessary.

Identification

- 1. Punching Head
- 2. Return Button
- 3. LED Indicator (red)
- 4. Battery Lock
- 5. Battery Cartridge
- 6. LED Work Light (white)
- 7. Trigger

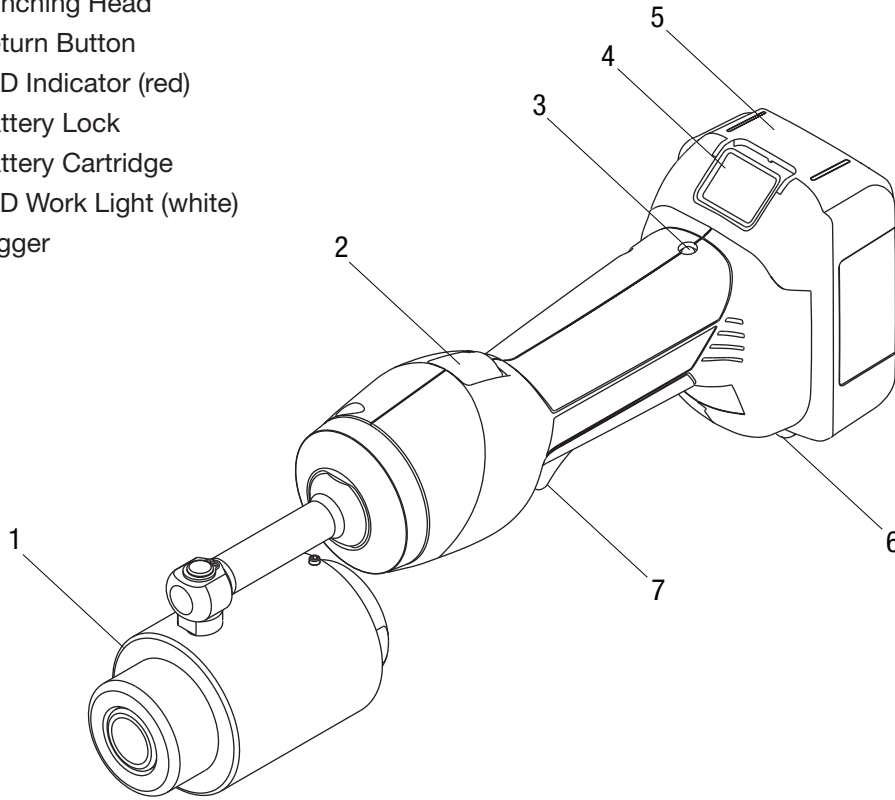

Specifications

Punch Driver (with 18V, 3.0 Ah lithium-ion battery)

Length.....	14.5" (368 mm)
Width	2.9" (73 mm)
Depth.....	4.7" (120 mm)
Weight.....	5.8 lb (2.6 kg)
Force.....	11.2 tons (100 kN)
Hydraulic Oil	52057878 biodegradable hydraulic fluid
Recommended Operating Temperature Range.....	5 °F to 122 °F (-15 °C to 50°C)
Battery Charger.....	Read the instructions supplied with the battery charger

52047087	120 VAC corded adapter	52049201	120 VAC, 18V charger
52047088	230 VAC corded adapter	52049202	230 VAC, 18V charger
52049190	18V, 1.5 Ah lithium-ion battery	52049204	12 VDC, 18V charger
52049189	18V, 3.0 Ah lithium-ion battery		

Setup and Operation

Punching

Note: The LS100L is a microprocessor-controlled hydraulic punching tool with an automatic shut-off feature that will engage after 1 second of operation, if no punching begins. This feature saves power and helps insure the full stroke is available for punching.

1. Refer to the illustrations on the following pages for proper punch, die, spacer, and draw stud setup and assembly.
2. Select the appropriate punch, die, and draw stud for the desired hole size.
3. Determine and mark the exact location for the hole. Use a Greenlee Kwik-Stepper® step bit to drill a pilot hole slightly larger than the draw stud being used.
4. Depress the Return button to reset the ram to the starting position.
5. Thread the appropriate draw stud completely into the ram in the punching head.
6. If needed, place an appropriately sized spacer on the draw stud.
7. Slide the corresponding die onto the draw stud. The open end of the die should face away from the punching head.
8. Insert the draw stud through the pilot hole in the material being punched.
9. Thread the punch (cutting edge facing the material) onto the draw stud until the punch assembly is tight on the material surface.

Note:

- The 3-1/2" to 6" punches require a punch sleeve prior to assembly to the draw stud.
 - All of the punch threads must be engaged with the draw stud threads. If any punch threads are not engaged, remove spacer and reassemble the setup.
 - For SPEED PUNCH®, slide the punch onto the draw stud (cutting edge facing the material) and secure the SPEED LOCK to the draw stud.
10. Press and hold the trigger to complete the punch cycle. The LS100L will automatically shut off when it senses the punch is completely through the material.

IMPORTANT

- Release the trigger manually after the punch completes the hole in sheet metals thinner than 18 ga. (1 mm) and soft materials such as plastic.
- If overpressure is reached during the punch cycle, the tool will automatically shut off and return the ram to the starting position. This may indicate the operation attempted is beyond the capacity of the tool. The overpressure condition will also occur when the tool reaches full stroke. (Care should be taken to avoid driving the LS100L to full stroke, as this may cause damage to the punch and die).

11. After the punch cycle is complete, depress the Return button to reset the ram to the starting position. This operation should be performed after every punch cycle.

Note: Depressing the Return button at any time during the punch cycle will reset the ram to the starting position.

12. Unscrew the punch from the draw stud. Slide the die off the draw stud and remove any slugs from the die.

Note: For SPEED PUNCH®, remove the SPEED LOCK. Slide the punch off the draw stud; then slide the die off the draw stud and remove any slugs from the die.

Charging the Battery

Read the instructions supplied with the battery charger.

LED Work Light (white)

This LED automatically turns on when the trigger is pulled. It remains on for 10 seconds after the trigger is released.

LED Indicator (red)

This tool is equipped with a special circuit board incorporating several important features to inform the user about the current status of the unit. The LED signals in the following cases:

What happens	Signal	What it means
Flashing light for 2 seconds	● ●	Battery is inserted in tool
Constant light for 20 seconds at end of cycle	■	Battery charge is below 17 V at beginning of cycle
Tool will not start, and constant light for 20 seconds when trigger is released	■	Battery charge is below 16 V at beginning of cycle
Tool will stop, and constant light for 20 seconds after trigger is released	■	Battery voltage drops below 13 V during cycle
Tool will stop, and flashing light for 20 seconds when trigger is released	● ● ● ●	Motor current exceeds 20 A during cycle Circuit has become too hot

Setup and Operation (cont'd)
STAINLESS STEEL

Note: Refer to "Capacity and Draw Stud Selection Guide" on page 12 for capacity, draw stud, and hardware.

Punching Stainless Steel

- 1/2" Conduit Size
(dia. 0.885" / 22.5 mm)

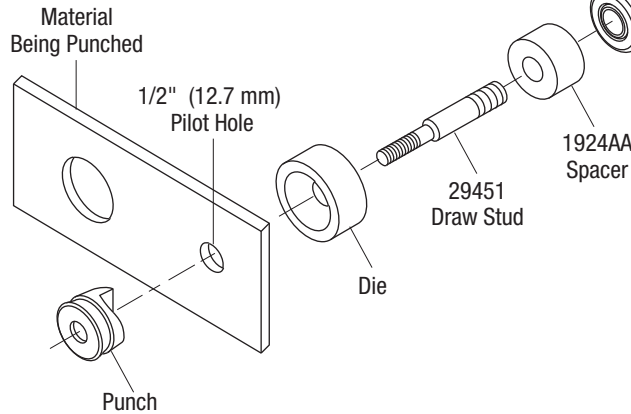
Punching Stainless Steel

- 3/4" to 3" Conduit Size
(dia. 1.115" to 3.539" / 28.3 mm to 89.9 mm)

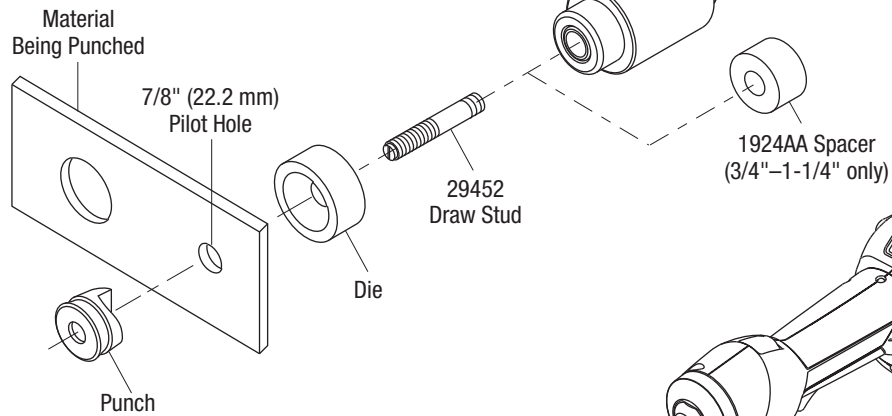
Punching Stainless Steel

- 3-1/2" to 4" Conduit Size
(dia. 4.011" to 4.544" / 102.7 mm to 115.4 mm)

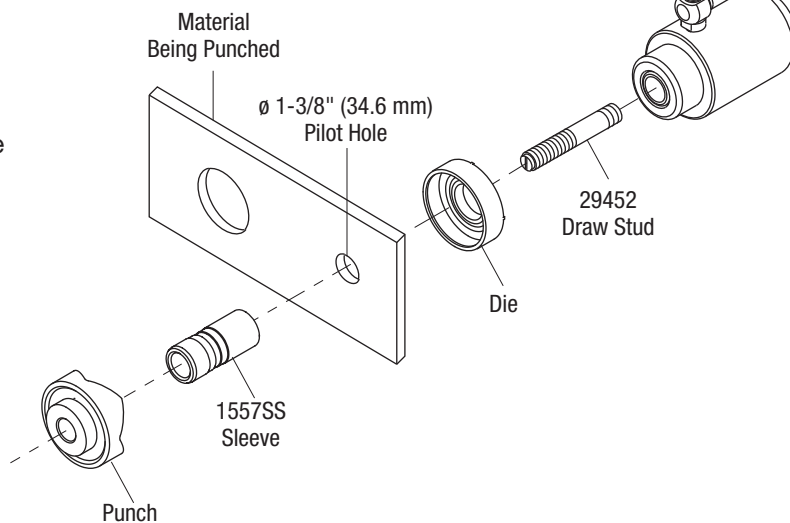

Setup and Operation (cont'd)
MILD STEEL

Note: Refer to "Capacity and Draw Stud Selection Guide" on page 12 for capacity, draw stud, and hardware.

Punching Mild Steel

- 1/2" Conduit Size
(dia. 0.885" / 22.5 mm)

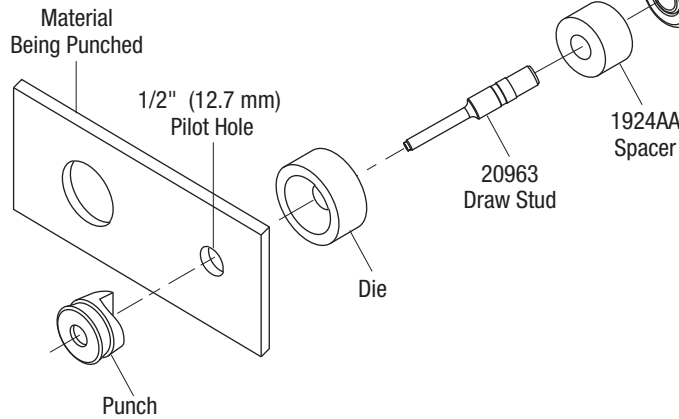
Punching Mild Steel

- 3/4" to 3" Conduit Size
(dia. 1.115" to 3.539" / 28.3 mm to 89.9 mm)

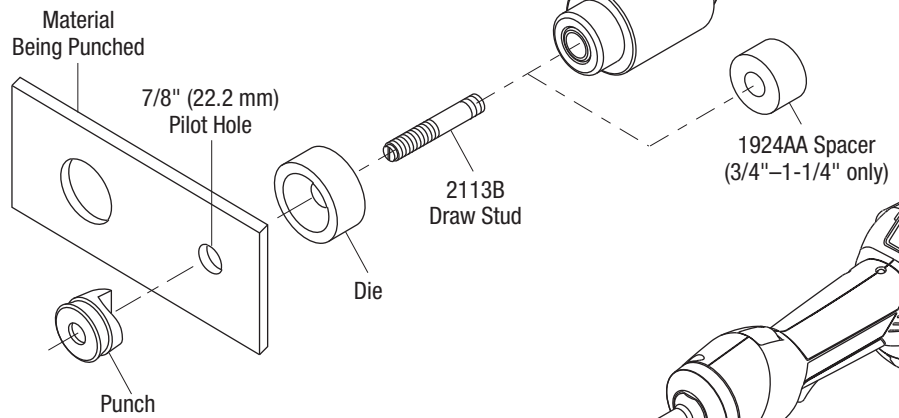

Punching Mild Steel

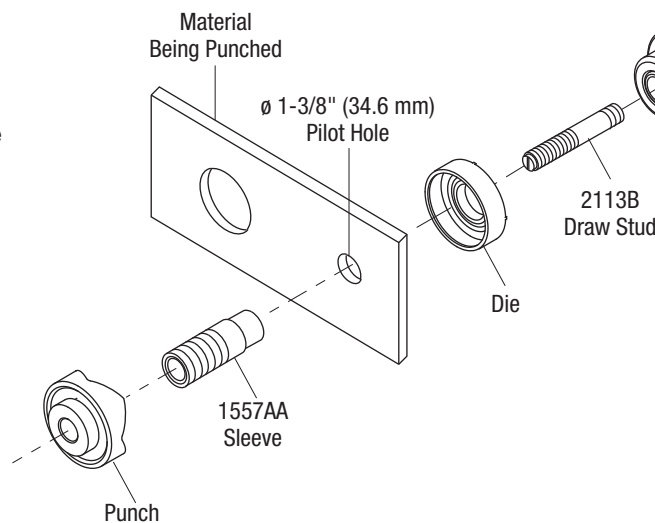
- 3-1/2" to 6" Conduit Size
(dia. 4.011" to 6.375" / 102.7 mm to 161.9 mm)

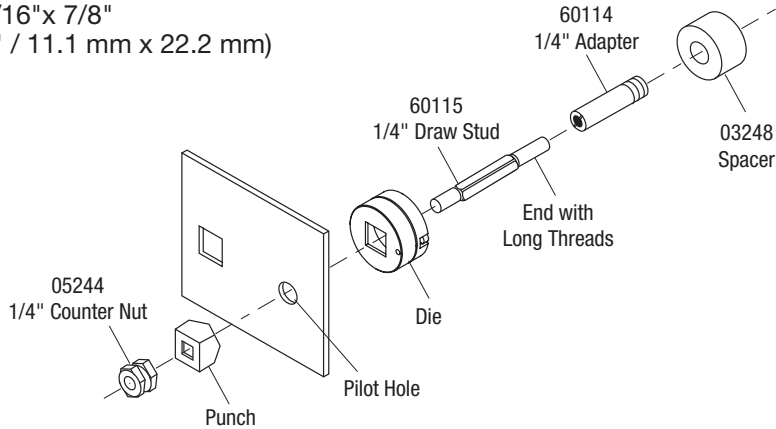

Setup and Operation (cont'd)
MILD STEEL
Punching Mild Steel

- Square: 1/2" (0.500" / 12.7 mm)
- Rectangular: 7/16"x 7/8"
(0.437"x 0.875" / 11.1 mm x 22.2 mm)

Punching Mild Steel

- Square: 5/8" to 0.945"
(0.625" to 0.945" / 15.9 mm to 24.0 mm)
- Rectangular: 0.670" x 0.749"
(17.0 mm x 19.0 mm)

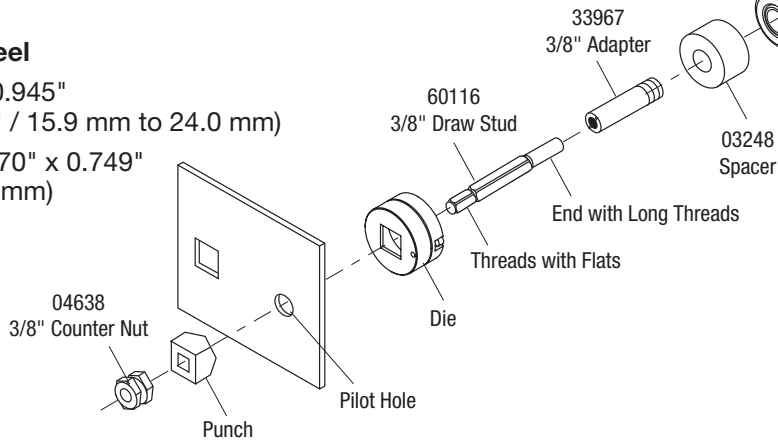
Punching Mild Steel

- Square: 1" (1.000" / 25.4 mm)
- Rectangular: 0.750"x 1.140" to 1.250" x 1.380"
(19.1 mm x 29.0 mm to 31.8 mm x 35.1 mm)

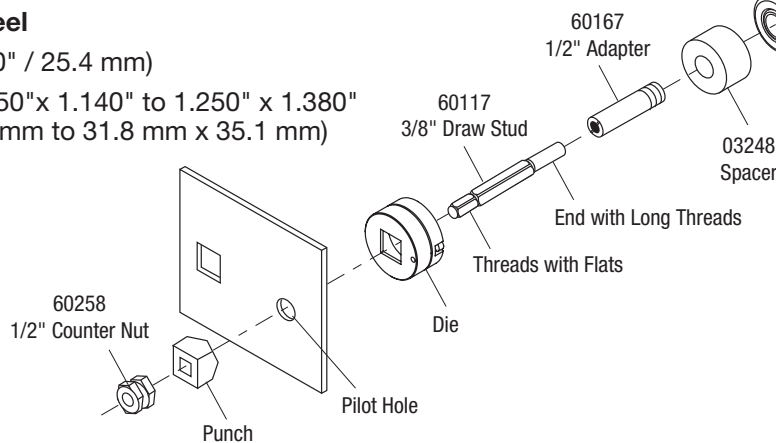

Setup and Operation (cont'd)

MILD STEEL

Punching Mild Steel

- Square: 1.811" to 2.677" (46.0 mm to 68.0 mm)
- Rectangular: 1.312" x 2.625" to 1.378" x 2.559" (33.3 x 66.7 mm to 35.0 mm x 65.00 mm)

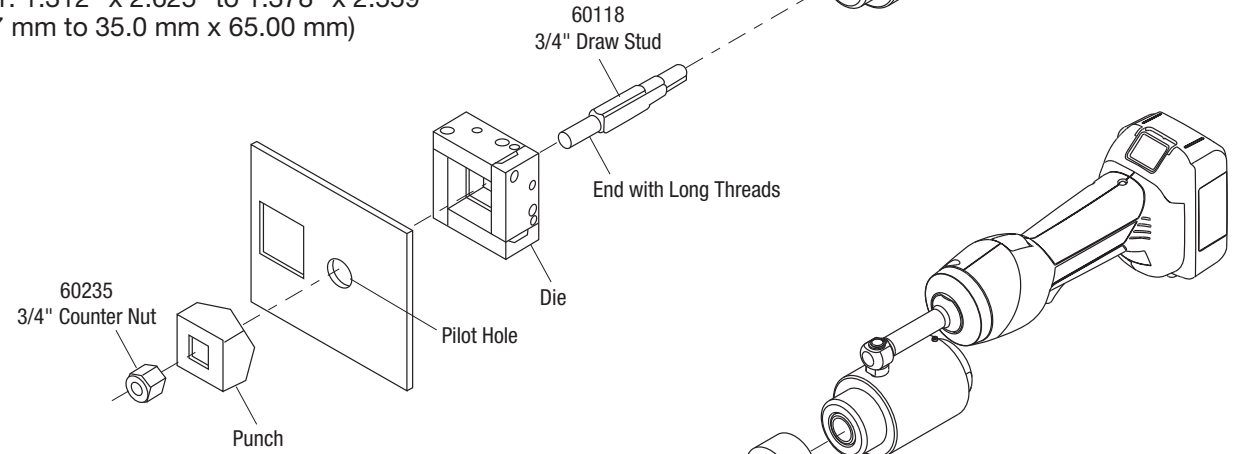

Punching Mild Steel

- "D" Punches
- Double "D" Punches
- Key Punches

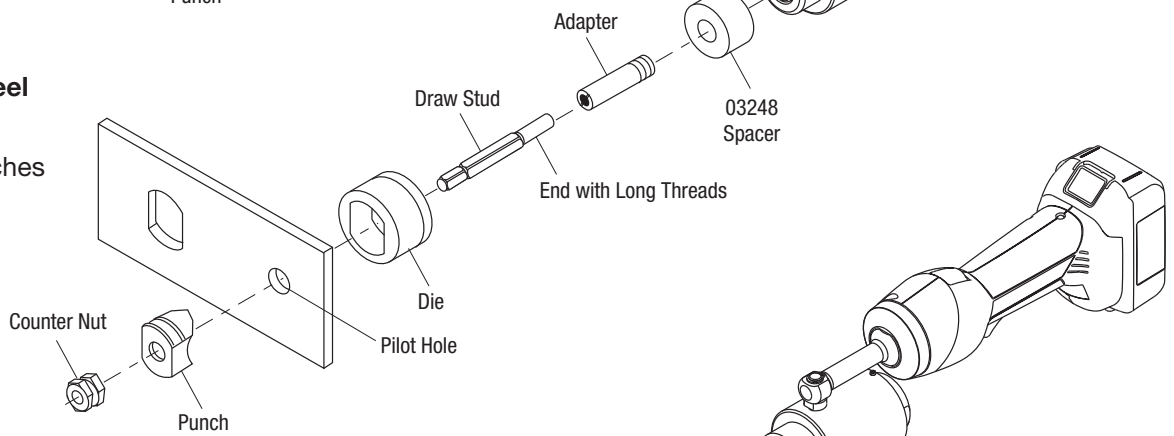

Punching Mild Steel

- Electronic Connector Panel Punches

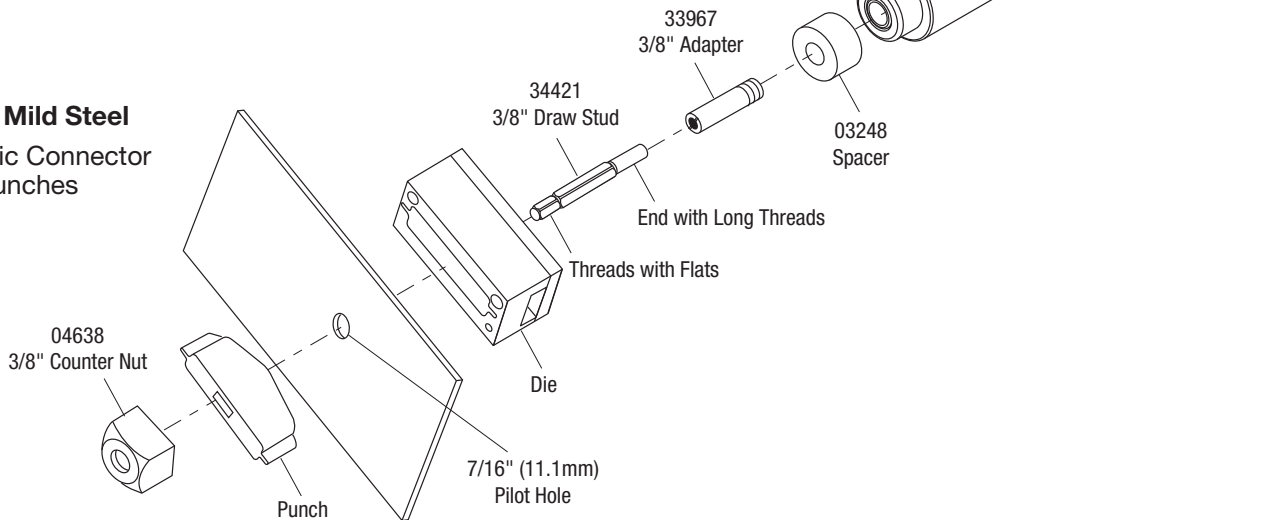

Capacity and Draw Stud Selection Guide

STAINLESS STEEL				
Slug-Splitter and Large Diameter Punches / Draw Studs				
Steel Gauge	PIPE AND CONDUIT SIZE			
	1/2"	3/4" to 1-1/4"	1-1/2" to 3"	3-1/2" to 4"
10 ga. (0.134", 3 mm)	C, E	D, E	D	N/A
12 ga. (0.104", 2.5 mm)				D, G
14 ga. (0.074", 2 mm)				

MILD STEEL					
Standard and Slug-Buster Punches / Draw Studs					
Steel Gauge	PIPE AND CONDUIT SIZE				
	1/2"	3/4" to 1-1/4"	1-1/2" to 3"	3-1/2" to 4"	5" to 6"
10 ga. (0.134", 3 mm)	A, E	B, E	B	B, F	N/A
12 ga. (0.104", 2.5 mm)					B, F
14 ga. (0.074", 2 mm)					B, F

MILD STEEL	
Electronic Connector Punches	
Steel Gauge	
	RS232, 229, 231, 234, 238
16 ga. (0.0598", 1.5 mm)	33967 adapter, 1924AA spacer

Key

Item	Draw Stud and Hardware	
	Catalog No.	Description
A	20963	3/8" x 4.8" draw stud
B	2113B	3/4" x 5.38" draw stud
C	29451	7/16" x 4.25" draw stud (stainless steel)
D	29452	3/4" x 5.5" draw stud (stainless steel)
E	1924AA	7/8" spacer
F	1557AA	1-1/8" x 3" punch sleeve
G	1557SS	1-1/8" x 3" punch sleeve (stainless steel)

Maintenance

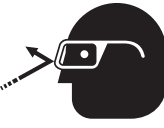
	⚠ WARNING
	<p>Wear eye protection when operating or servicing this tool.</p> <p>Failure to wear eye protection could result in serious eye injury from flying debris or hydraulic oil.</p>

	⚠ WARNING
	<p>Skin injection hazard:</p> <p>Do not use hands to check for oil leaks. Oil under pressure easily punctures skin. If injured, seek medical attention immediately to remove oil.</p> <p>Failure to observe this warning could result in serious injury, gangrene, or death.</p>

	⚠ WARNING
	<p>Do not use solvents or flammable liquids to clean the tool body. Solvents or flammable liquids could ignite and cause serious injury or property damage.</p>

	⚠ WARNING
	<p>Pinch points:</p> <ul style="list-style-type: none"> • Remove battery before changing dies, adapters, or jaws. • Keep hands away from the tool head when punching. <p>Failure to observe these warnings could result in severe injury or death.</p>

IMPORTANT
Relief valve adjustments must be done by an authorized service center.

Daily

Before use:

1. Inspect the tool for wear or damage, such as cracks, gouges, or chips.
2. Inspect the tool for damage or leaks.
3. Inspect the rotation of the head assembly. Fully return the ram. The head should rotate freely. If damage is detected, send the tool to a Greenlee Authorized Service Center for inspection.

After use:

1. Use a damp cloth and mild detergent to clean the housing. Allow the housing to dry.
2. Fully return the ram. Place the tool in the carrying case and store in a cool, dry place.
3. If necessary, recharge the batteries. Refer to the instructions supplied with the battery charger.

Monthly

1. Thoroughly clean all surfaces.
2. Check the oil level.

Annually or After 10,000 Punches

1. Replace the hydraulic oil.
2. Send the tool to a Greenlee Authorized Service Center for inspection.

Checking the Oil Level

1. Remove the screws holding the housing cover together.
2. Point the tool head downward and remove the oil reservoir plug. Fill reservoir if necessary.
3. Replace the oil plug and housing cover.

Note: For Warranty Service or Repair, contact Greenlee customer service at 800-435-0786.

Troubleshooting

Before You Begin

1. Make sure that the battery is charged. Recheck the battery after several minutes to make sure the battery is holding its charge.
2. Use a **nonflammable** contact cleaner or pencil eraser to clean the electrical contacts on the battery and tool.
3. Reinstall the battery and check the tool again.

Problem	Possible Cause	Probable Remedy
Tool is inoperative.	Dirt, contaminants, etc., in ram area of tool.	Clean tool.
	Tool components worn or damaged.	Return tool to a Greenlee Authorized Service Center.
Motor is inoperative.	Low or uncharged battery.	Try known charged battery. Inoperative battery may be discharged or may have reached life expectancy.
	Broken switch components.	Return tool to a Greenlee Authorized Service Center.
Motor runs but tool will not complete a cycle.	Oil level low.	Return tool to a Greenlee Authorized Service Center.
	Air in hydraulic system.	Pull trigger and hold return button simultaneously. Run for approximately 10 seconds, and then attempt to punch. If unsuccessful, return tool to a Greenlee Authorized Service Center.
	Cold oil.	Pull trigger and hold return button simultaneously to warm oil. Store tool in warm area.
Dies stop during operation.	Oil level low.	Return tool to a Greenlee Authorized Service Center.
	Air in hydraulic system.	Pull trigger and hold return button simultaneously. Hold for approximately 10 seconds.
LED glows for 20 seconds.	Battery charge low.	Charge or replace battery.
Tool loses oil.	Damaged internal seal.	Return tool to a Greenlee Authorized Service Center.

Note: For Warranty Service or Repair, contact Greenlee customer service at 800-435-0786.



4455 Boeing Drive • Rockford, IL 61109-2988 • USA • 815-397-7070
An ISO 9001 Company • Greenlee Textron Inc. is a subsidiary of Textron Inc.

www.greenlee.com

USA Tel: 800-435-0786
Fax: 800-451-2632

Canada Tel: 800-435-0786
Fax: 800-524-2853

International Tel: +1-815-397-7070
Fax: +1-815-397-9247