



**LG**

# SERVICE MANUAL

## REFRIGERATOR

### ATTENTION

**Before start servicing, carefully read the safety instructions in this manual**

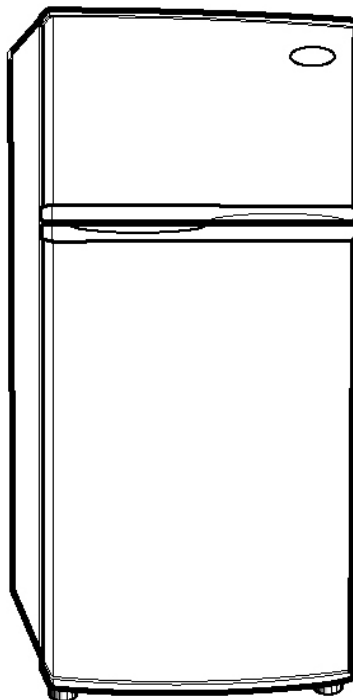

**MODEL(S): GR-382R  
LRTP1231W**



# Contents

---

<b>Safety Precautions</b> .....	1
<b>Service Precautions</b> .....	2-3
<b>Specifications</b> .....	4
<b>Feature Chart</b> .....	5
<b>Circuit Diagram</b> .....	6-7
<b>Cooling Systems</b> .....	8
<b>Product Disassembly</b> .....	9-11
Doors .....	9
Door Switch .....	9
Electronic Control Display PCB .....	9
Freezer Fan .....	10
Defrost Control .....	10
Lamp .....	10
Refrigerator Control Box .....	11
<b>Reversible Door</b> .....	12-13
<b>Adjustments</b> .....	14-15
Compressor .....	14
PTC Starter .....	14
Overload Protector (OLP) .....	15
<b>Troubleshooting</b> .....	16-21
Compressor & Electrical Components .....	16
PTC & OLP .....	17
Other Electrical Components .....	18
Service Diagnosis Chart .....	19
Refrigerant Cycle .....	20-21
<b>MICOM circuit &amp; operation</b> .....	22-39
<b>Refrigerator Exploded View</b> .....	40-41
<b>Service Parts list</b> .....	42-43



## Safety Precautions.

**Read the following instructions before servicing your refrigerator.**

1. Unplug the refrigerator before servicing.
2. Visually inspect for gas leakage or short circuit.
3. If testing with the refrigerator plugged in, wear rubber gloves to avoid electric shock.
4. Do not touch frozen metal parts; your hands could freeze to the surface. This may cause frostbite.
5. Be sure that no water is dripping towards electrical or metal parts.
6. If you check the bottom part of the refrigerator while the freezer door is open, be careful standing up. You could bump your head.
7. When you tilt your refrigerator be sure to take out all metal, glass, or other loose parts.
8. When servicing the evaporator, wear cotton gloves to prevent cutting by any of the evaporator fins.

# Service Precautions

## Refrigerant Recharging

Test the compressor's operation before recharging the refrigerant; this is very important to detect failures and to ensure the proper motor running, and to identify failures immediately. If failure has been detected, clean the system from any other possible R-134a residues by breaking the final part of the compressor's service pipe at its thinnest part as shown in Fig. #1. Replace the filter and any other part that could be deteriorated. Unweld and pull out the service pipe, then place a new pipe extension with a Hansen male connector and solder the new pipe. See Fig. #2

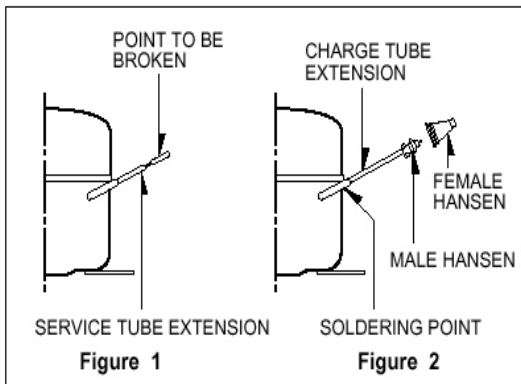

It is necessary to open the valve when soldering to allow the gases to escape without forcing the molten solder out of the joint. The extension with the male Hansen connector should be connected to a female type connector to the vacuum pump's pipe. See Fig. #3

System air evacuation starts as soon as the pump begins to run. The system must be kept under vacuum until the low pressure gauge shows

0 (absolute or -1 atm, -760 mm Hg.) It is not recommended to run the vacuum pump for more than 30 minutes. See

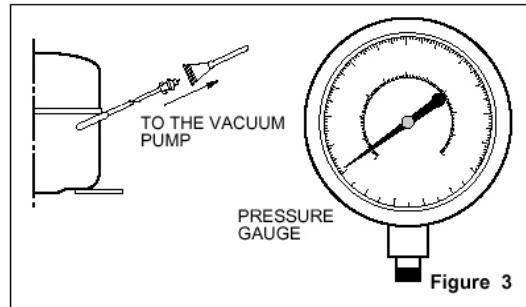
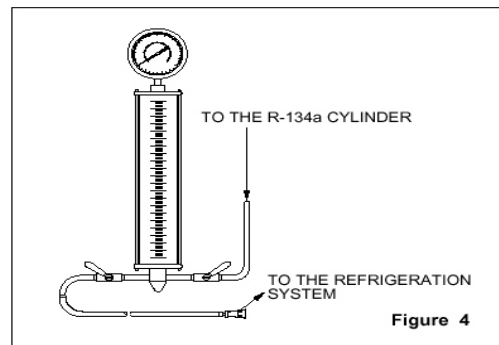

Figure 3. In case there is a large leak and the vacuum operation must stop, you must add a small amount of refrigerant to the system and check with an electronic leak detector. If a soldering failure is detected, open the valve before soldering to equalize the pressure and keep solder from being blown out of the joint or sucked into the piping.

As soon as the repair is completed, charge the correct amount of refrigerant into the system. Remember that each system requires a specific amount of refrigerant with a tolerance of  $\pm 5$  grams. See Figure 4.



Before performing this operation (if the vacuum pump and charging cylinder are still attached to the system) be sure the valve between the pump and the cylinder is closed to

# Service Precautions

keep refrigerant out of the system. See Figure 5.

For gas charging, check the graduated scale on the cylinder to see the amount of refrigerant that it contains and the amount that will be pumped into the system. For example, if you have 750 grams of refrigerant in the cylinder and we have to pump 165 grams to the system, this amount will be reached when the indicator reaches 585 grams; remember that the indicator shows a lower level of meniscus.

Do this after choosing the scale corresponding to the gas pressure indicated on the pressure indicator located on the upper part of the column. To let R-134a flow into the system, open the valve at the recharging cylinder's base. The total amount of refrigerant should not be

installed in one session, as it could block the compressor. Install 20~30 grams at a time and close the valve. The compressor will run and the pressure will drop. Then open the valve and install other 20~30 grams of refrigerant. Repeat this procedure until the entire amount has been added to the system. Under operating conditions, the system pressure should stabilize between 0.3 and 0.6 atm.

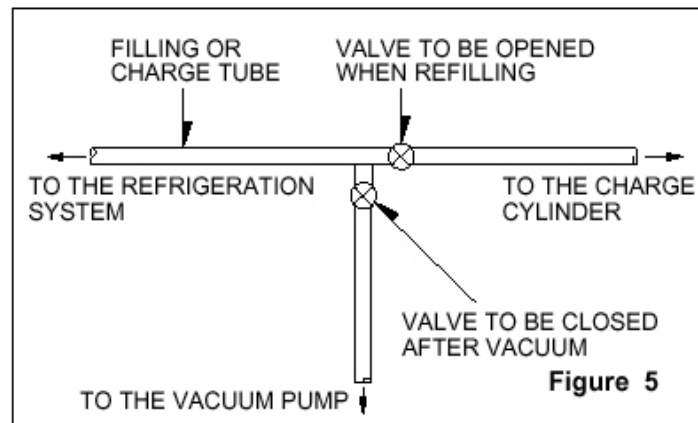



# Feature Chart

## FREEZER

Temperature Control

Shelf

Ice Trays  
Twist 'n Serve

Freezer  
Door Baskets

## REFRIGERATOR

Temperature Control

Fresh Meat  
Tray

Lamp

Shelves  
(Plastic or Glass)

Deodorizer  
(Absorbs  
Odors)\*

Multi Air Flow  
Air flow distributor

Vegetable Tray  
(Keeps fruits and  
vegetables fresh)

Refrigerator  
Door Baskets

Leveling  
Screws

Magic Crisper  
(Vegetable Tray cover  
that control humidity)

**MODEL(S): GR-382R  
LRTP1231W**

\* This part is only included in model LRTP1231W



# Graphic Circuit Diagram

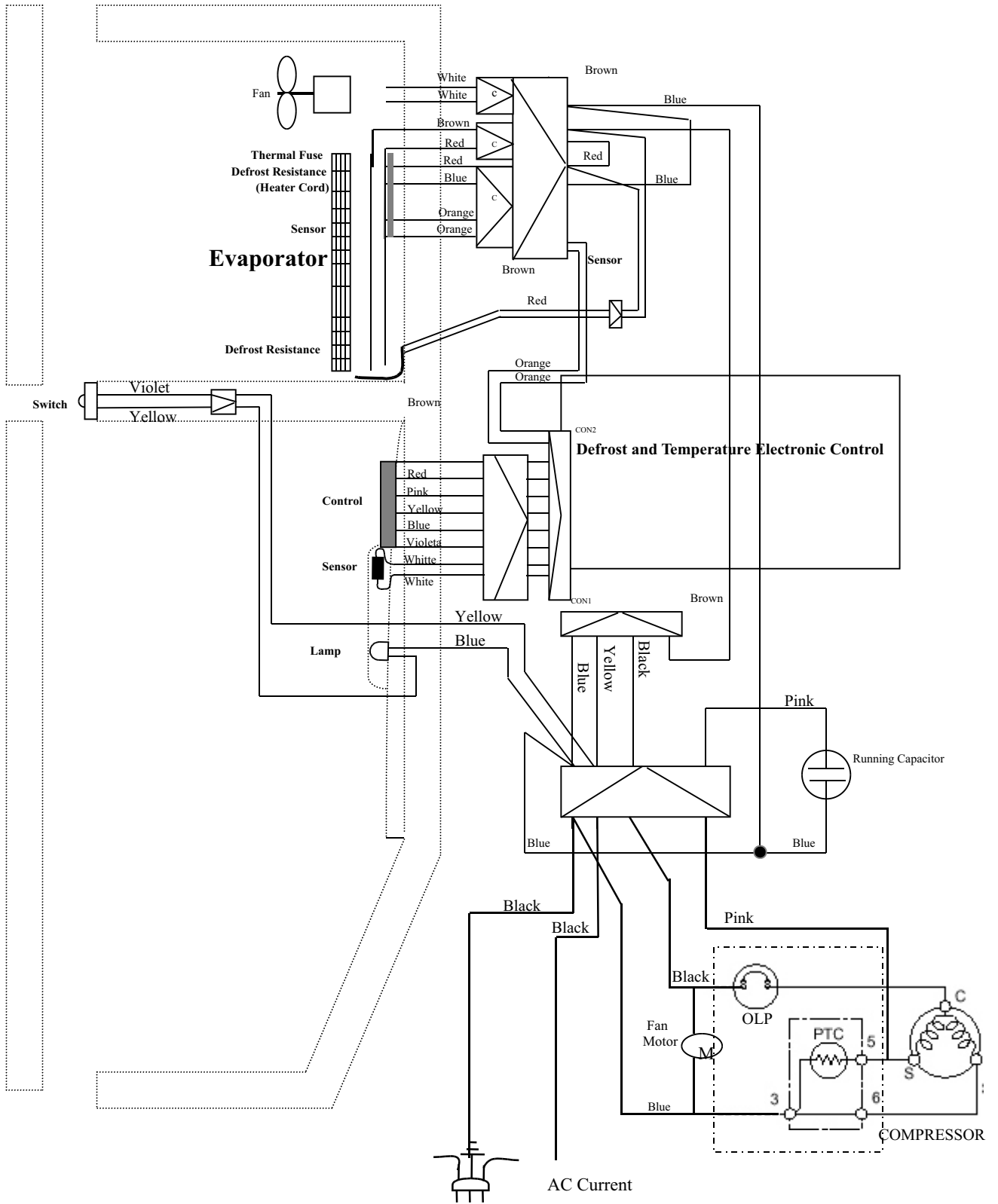



# Cooling Systems

Direct System

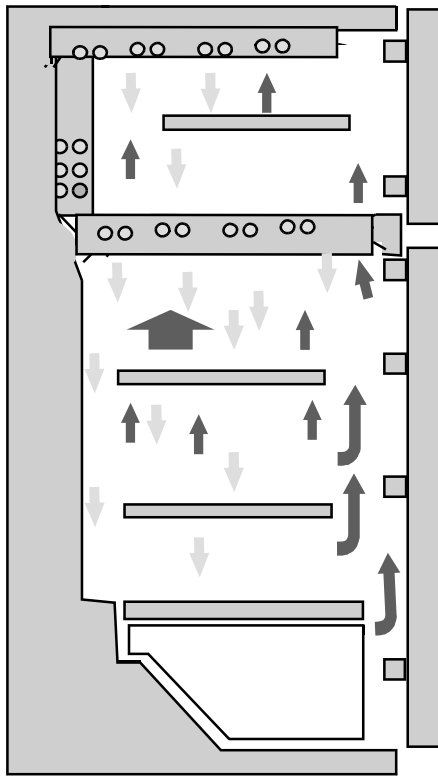

Indirect System

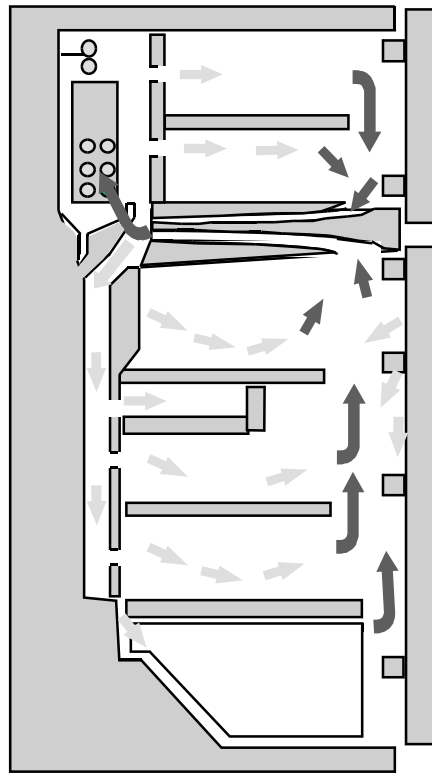

→ Cold Air

→ Warm Air

**Important:** Check that the air ducts are not obstructed for a better cooling performance.

Temperature variation during defrosting time, depending upon the cooling system .

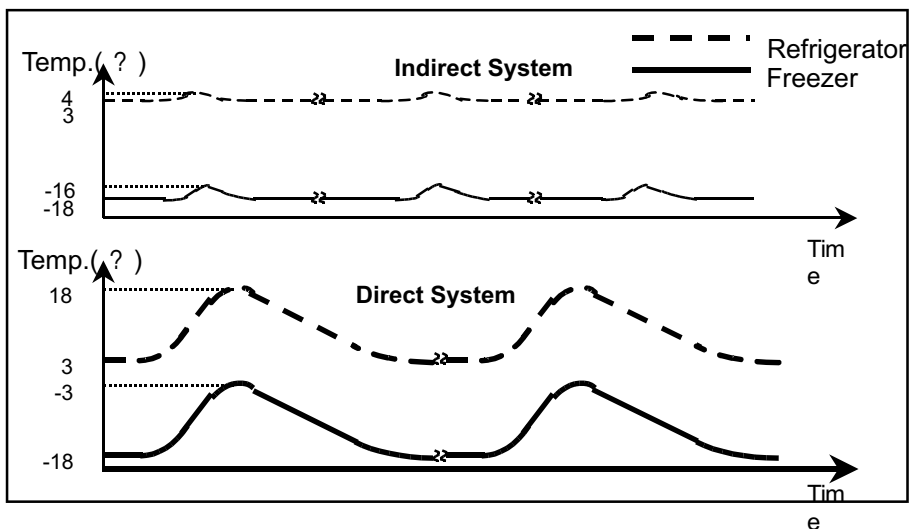

# 3. Product Disassemble.

## Doors

### ● Freezer Door

1. Remove hinge cover by pulling it upwards.
2. Loosen the hexagonal bolts that hold the upper hinge in place. See Figure 1.
3. Remove door. See Figure 2.



Figure 1



Figure 2

4. Pull gasket to remove it. See Figures 3 and 4.



Figure 3



Figure 4

### ● Refrigerator Door

1. Loosen the hexagonal bolts that hold the central hinge in place. See Figure 5.
2. Remove refrigerator door. See Figure 6.
3. Pull out the gasket to remove it from the door. See Figure 4 from Freezer door.



Figure 5



Figure 6

### Door Switch

1. Pull out the door switch out using a flat head screwdriver. See Figure 7

2. Disconnect all switch's cables. See Figure 8



Figure 7



Figure 8

### Control Circuit ( Display PWB)

1. Remove the lamp cover by inserting a screwdriver in the lower side's holes. See Figure 9.
2. Loosen and remove the 2 screws. See Figure 10.



Figure 9



Figure 10

3. Pull out the Control Box. See Figure 11.
4. Disconnect the connector from the cable terminal. See Figure 12.
5. Remove the EPS Multi air duct (insulation) from the control box.
6. Detach the electronic control (Display, PWB). See Figure 13.



Figure 11



Figure 12



Figure 13

### Fan and Fan Motor.

1. Remove freezer shelf.
3. Remove the ice bin assembly by pulling it to the right side, until it snaps out.
4. Remove Grill Fan screw cover. See Figure 14.
5. Loosen the screw. See Figure 15.
6. Pull out the fan cover. Figure 16.



Figure 14



Figure 15

6. Unplug the connector.
7. Remove the fan holder shroud. Figure 17.
8. Remove fan and loosen both screws that hold the bracket.
9. Remove the motor bracket and the rubber parts. Pull out the fan motor. See Figure 17.



Figure 16



Figure 17

### Defrost Control Assembly

1. The defrost control assembly consists of one thermistor and a fuse that melts with heat.
2. The thermistor's function is to sense the compartment's temperature and automatically stop the defrost. The thermistor is located beside of the evaporator bracket.
3. The melting fuse is a safety device to prevent an overheating of the defrosting resistance when it operates.
4. The fuse melts at 162° F and the resistance heater stops.
5. To replace this components, please follow the steps mentioned at Figure 18.

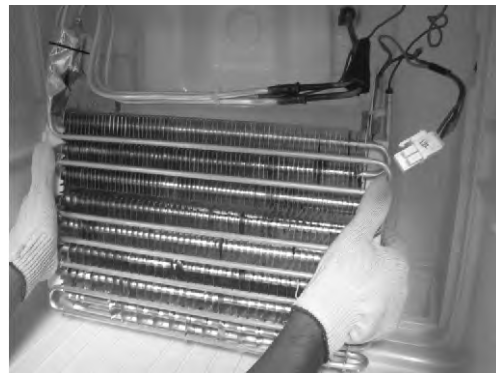

1. Figure 18. Unplug the connector plugged to the defrost control assembly and replace it if necessary.

### Lamp.

#### Refrigerator Compartment Lamp

1. Remove the lamp cover with a screwdriver or a similar tool. See Figure 19.
2. Remove the lamp by unscrewing it counterclockwise and replace it with the same specifications (125V,20W). Part Number 6912JB2002J.



Figure 19

### Refrigerator Control Box.

Remove the lamp cover as mentioned before.

1. Loosen the screws.
2. Remove the entire control box.  
See Figure 20.
3. Disconnect the control box connector. See Figure 21.



Figure 20

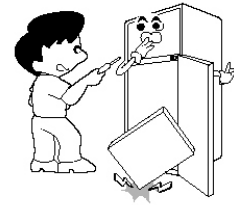

Figure 21

# 4. Reversible Door

## PRECAUTION

1. Before reversing the doors, remove all foods and accessories, like shelves or trays, which are not attached to the doors.
2. Use a Philips screwdriver, bolt driver, torque wrench, or spanner to tighten and loosen the bolt.
3. Be careful not to drop the refrigerator or door when assembling or disassembling lower hinge or the Adjustable Screw Assembly.
4. Don't lay the refrigerator down to work on it. It will cause malfunction.
5. The doors may be reversed to provide left or right opening, depending upon the customer's preference.



## HOW TO REPLACE THE DOOR OPENING LEFT TO RIGHT (when converting from left-opening to right opening)

- 1** Remove the cap £U and upper hinge £V

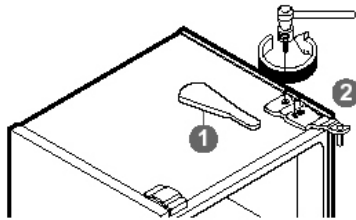

- 2** Remove the Freezer Door £W

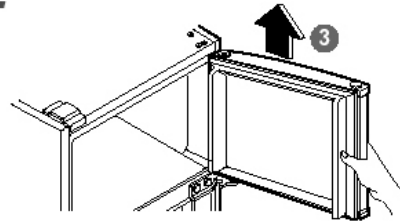

- 3** Remove the center hinge £X and the Refrigerator Door £Y

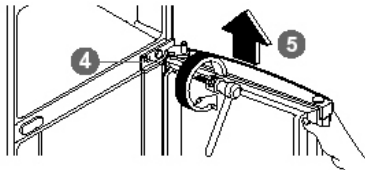

- 4** Remove the lower hinge £Z

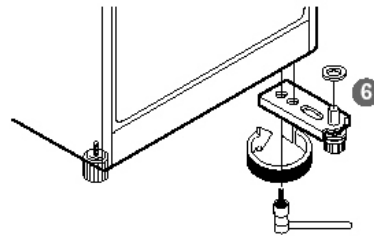

**5** Reverse the position of the adjustable screw assembly  $\epsilon$  [

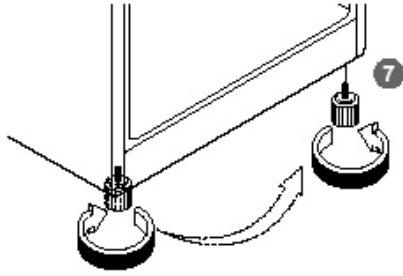

**6** Assemble the lower hinge  $\epsilon$  Z

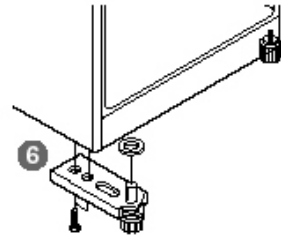

**7** Move the cap and bracket to the opposite side of the refrigerator door

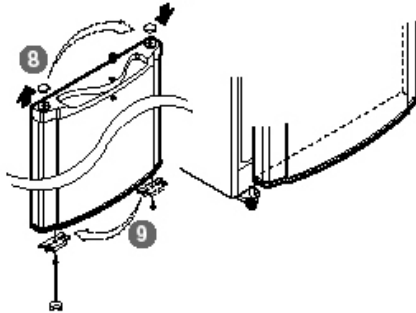

**8** Move the cap to the opposite side and assemble the center hinge.

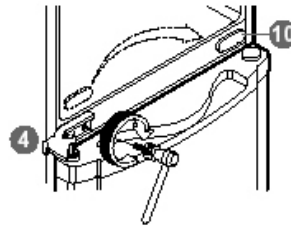

**9** Assemble the door stopper for the correct side

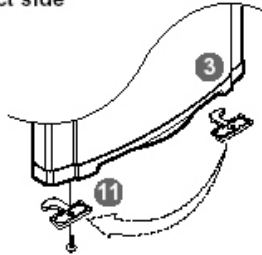

**10** Move the cap to the opposite side of the freezer door

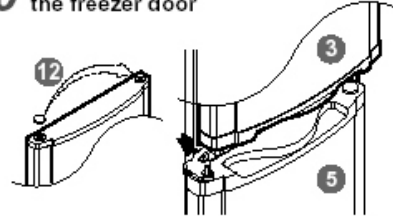

**11** Reverse the pin position of the upper hinge

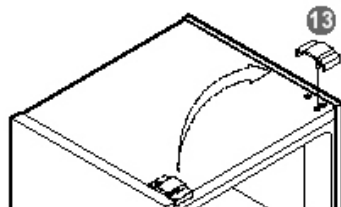

**12** Assemble the upper hinge and replace the cap

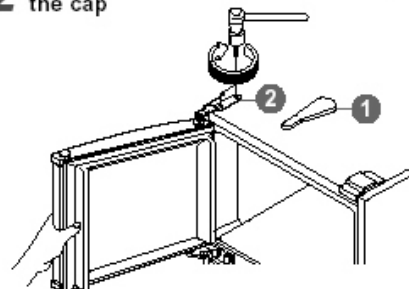

# 5. Adjustments

## 1- COMPRESSOR

### 1-1 Function

The compressor sucks low pressure evaporated gas from the evaporator and compresses it into high temperature/high pressure gas and sends it to the condenser.

### 1-2 Composition

The compressor includes the compressing system, a motor, and an enclosure. The PTC (thermistor) and OLP (Overload Protection Device) are attached to its exterior. Handle and repair the compressor with care. It includes parts manufactured to 1 micron tolerance, and is hermetically sealed to exclude dust or humidity after fabrication. Dust, humidity, or flux getting into the refrigeration cycle could clog it or otherwise affect the cooling.

### 1-3 Use notes.

- (1) Protect your refrigerator from over currents or overloads.
- (2) Do not bump or jar the compressor. If it is bumped or forced (dropping or careless handling,) it could damage the compressor or cause noise or undesirable operation.
- (3) Use only exact replacement parts when repairing the compressor. If the terminals become corroded, it could affect operation. If the replacement parts are of incorrect values, operation and safety will be compromised.

## 2- PTC

### 2-1 PTC Composition

- (1) The PTC (Thermistor) is a semiconductive starting component that is made with  $BaTiO_3$ .
- (2) The higher the temperature, the higher the resistance value will be. This characteristic is used for starting the motor.

### 2-2 PTC Function

- (1) The PTC is attached to the hermetic compressor and its used for its starting. This household refrigerator uses a single induction motor. During normal operation, the motor starts with current flowing through both the main and the auxiliary windings. After the motor starts, current to the auxiliary winding is cut off.

### 2-3 PTC- Electric Diagram

According to motor starting method.

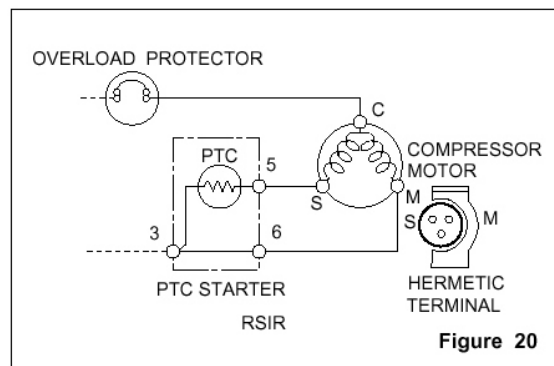

Figure 20

## 2-4 Motor restarting and PTC cooling.

- (1) To restart normal operation after a power interruption, wait 5 minutes to let the pressure equalize and the PTC to cool.
- (2) During normal operation, the PTC generates heat. If it has not had time to cool after a power interruption, the motor will not restart until the PTC cools.

## 2-5 PTC OLP Relation

- (3) If power is cut off during compressor operation and then restored before the PTC has cooled down, its resistance value increases. As a result, the current cannot flow to the auxiliary winding and the motor cannot start and the OLP operates due to the current overflow through the main winding.
- (3) While the OLP repeats the ON/OFF operation 3~5 times, the PTC cools and the compressor operates normally. If the OLP does not operate when the PTC is hot, the compressor motor will overheat, causing a short circuit or possibly a fire. Therefore, use a fail-safe OLP.

## 2-6 Note on using the starting PTC

- (1) Be careful not to cause an overvoltage or short circuit.
- (2) Do not force or bump it.
- (3) Keep the OLP dry. If water or oil gets into the OLP, the electrical insulation can degrade and fail.
- (4) Do not replace the PTC at your own convenience. Do not disassemble the PTC. If the PTC's exterior is damaged, the resistance value changes and may cause failure during the starting of the compressor's motor. Use a PTC in good condition.

## 3- OLP

### 3-1 OLP Definition

- (5) The OLP is a bimetallic, heat-sensitive switch attached to the compressor. Its function is to protect the motor in the event of overheating.
- (6) When an overvoltage flows to the motor, the bimetal reacts by heating and activating (opening) the OLP.

### 3-2 OLP Function

- (7) Prevents the starting to the motor winding.
- (8) Do not turn the adjustment screw during normal OLP operation. (OLP connection diagram)

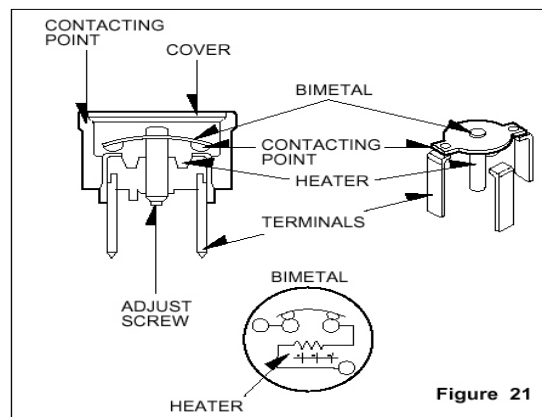
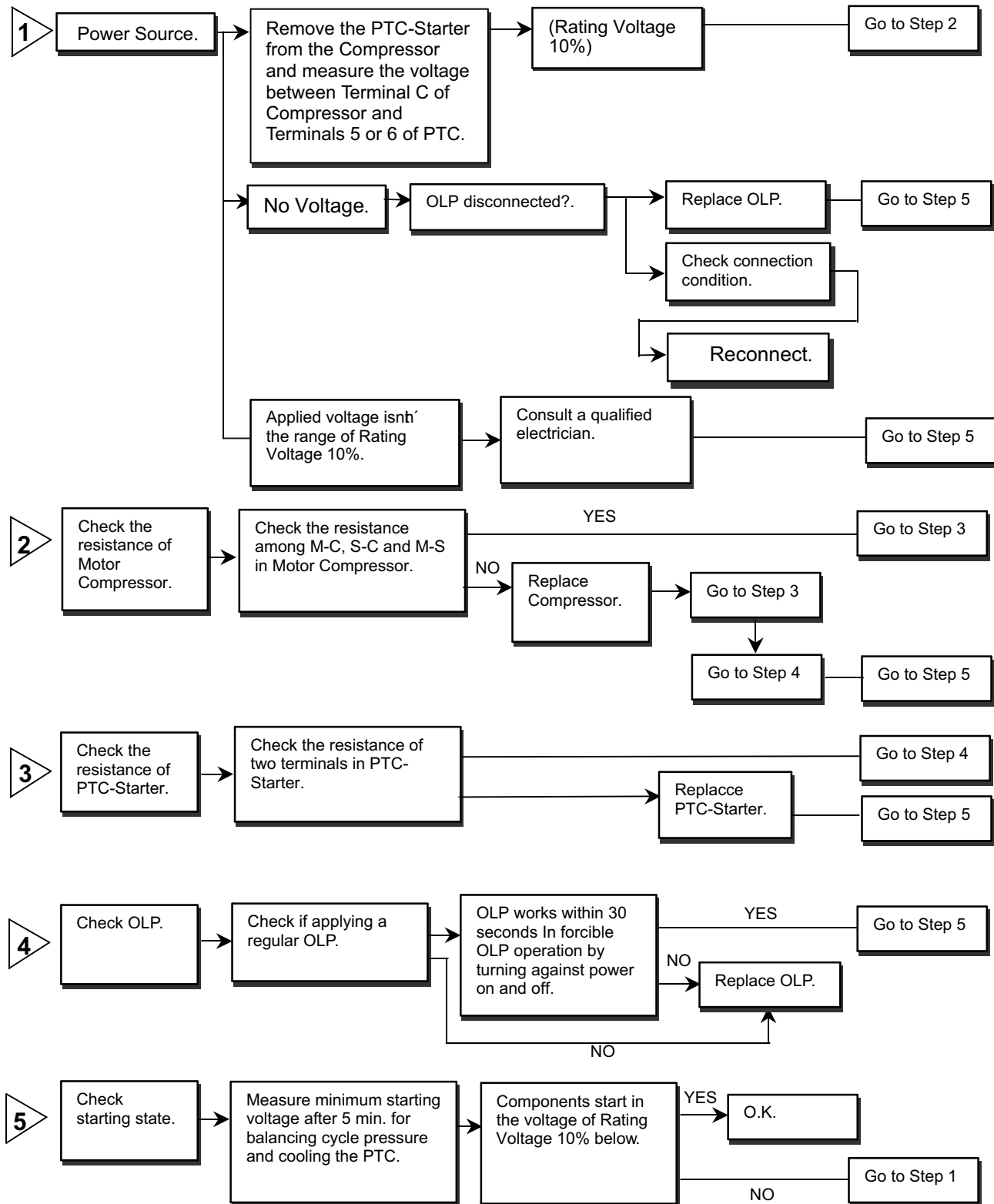

Figure 21



# 6. Troubleshooting

## 6-1 COMPRESSOR AND ELECTRIC COMPONENTS



## 6-2 PTC AND OLP

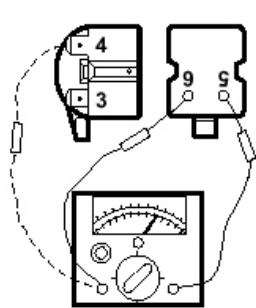
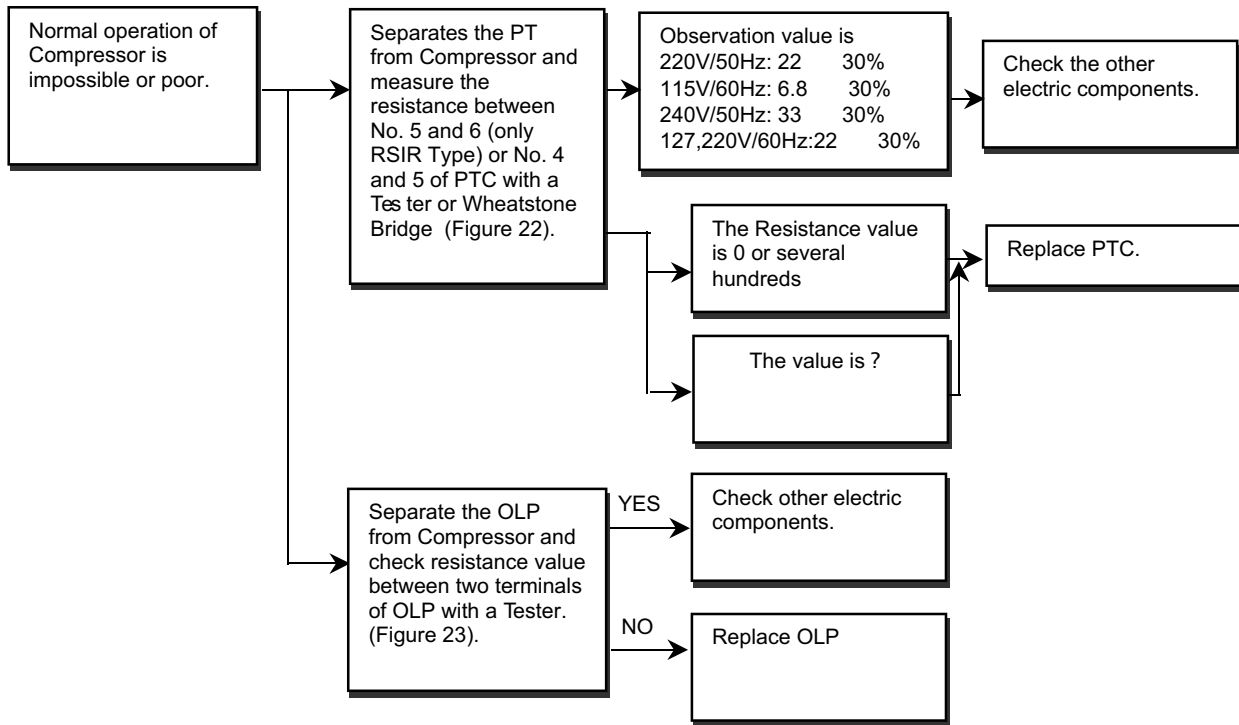

Figure 22

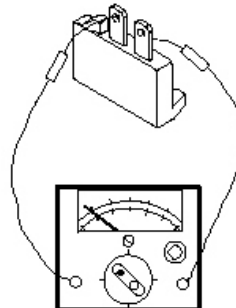
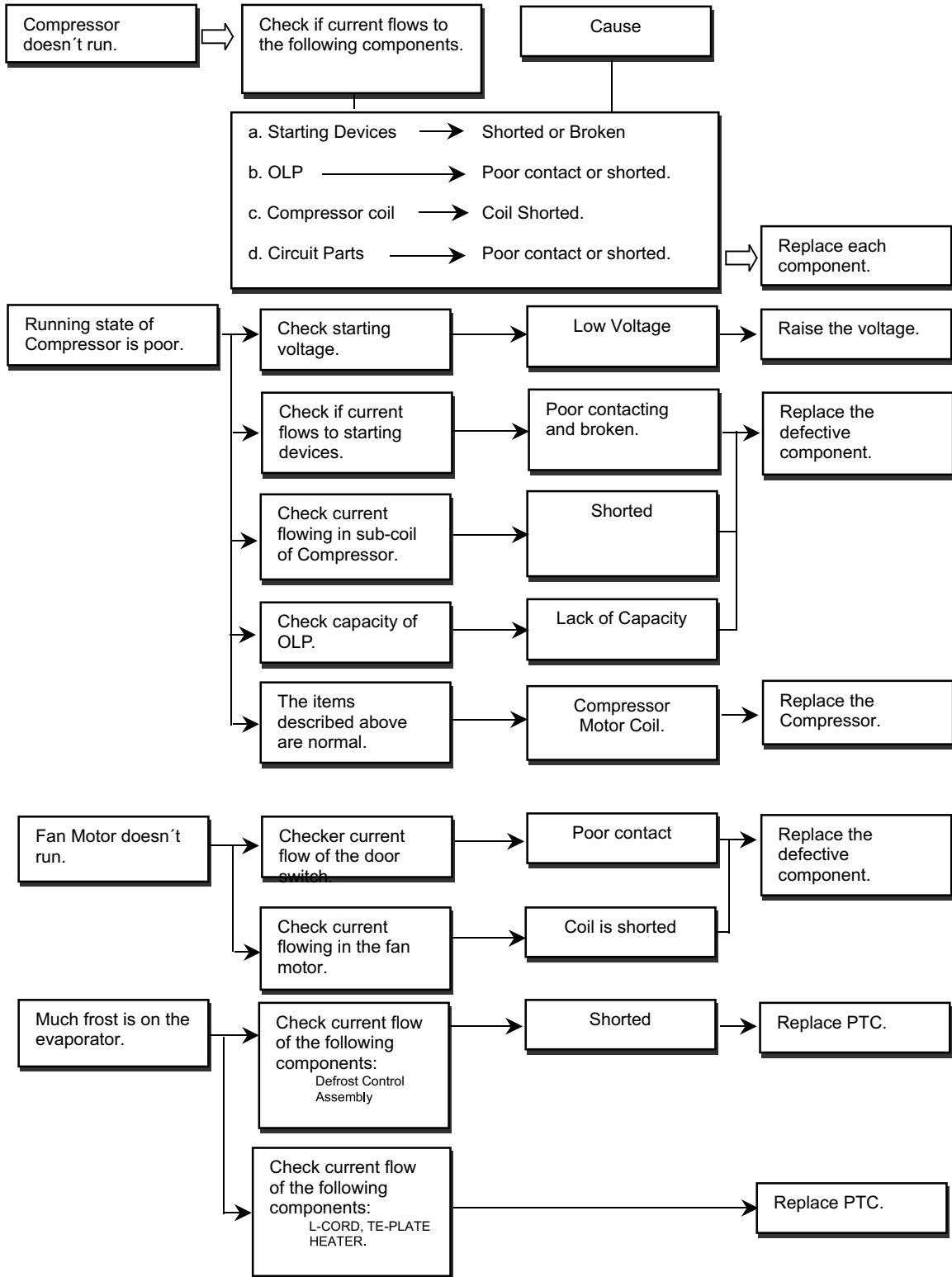

Figure 23

## 6-3 OTHER ELECTRIC COMPONENTS

### • No Cooling



## 6-4 SERVICE DIAGNOSIS CHART

COMPLAINT	POINTS TO BE CHECKED	REMEDY
No Cooling	<ol style="list-style-type: none"> <li>1. Is the power cord unplugged?</li> <li>2. Check if the power switch is set to OFF.</li> <li>3. Check if the fuse of power switch is shorted.</li> <li>4. Measure the voltage of power outlet.</li> </ol>	<p>Plug it to the outlet. Set the switch to ON. Replace a regular fuse. If the voltage is low, check the wiring or call an electrician.</p>
Poor Cooling	<ol style="list-style-type: none"> <li>1. Check if the refrigerator is placed close to a wall.</li> <li>2. Check if the refrigerator is placed close to a stove, oven or in indirect sunlight.</li> <li>3. Is the ambient temperature high or the room door closed?</li> <li>4. Check if putting in hot food.</li> <li>5. Did you open the refrigerator door too often?</li> </ol>	<p>Place the set with the space of about 10 cm. Place the set apart from these heat sources. Is the ambient temperature within spec? (above 10 C or 40 F ) Put food in after it cools. Don't open the door too often and close it firmly.</p>
Poor Freezing	<ol style="list-style-type: none"> <li>1. Is the ambient temperature too low? 10 C (40 F).</li> </ol>	<ol style="list-style-type: none"> <li>2. To make the freezer colder, set the COLD AIR CONTROL to 7 and set the R control button (PWB) to <b>MAX</b>.</li> </ol>
Food in the refrigerator is frozen	<ol style="list-style-type: none"> <li>3. Is food buckling the cooling air outlet?</li> <li>4. Check if the PWB is set to MAX.</li> </ol>	<ol style="list-style-type: none"> <li>5. Place food in high temperature section (Front Part).</li> <li>6. Set the button to <b>MID</b>.</li> </ol>
Moisture or ice forms in the chamber of the set.	<ol style="list-style-type: none"> <li>7. Is watery food kept?</li> <li>8. Check if putting in hot food.</li> <li>9. Did you open the refrigerator door too often?</li> </ol>	<ol style="list-style-type: none"> <li>10. Seal watery food with vinyl wrap.</li> <li>11. Put food after it cools.</li> <li>12. Don't open the door too often and close it firmly.</li> </ol>
Moisture forms on the outside	<ol style="list-style-type: none"> <li>13. Check if ambient temperature and humidity are high.</li> <li>14. Is there a gap in the door gasket?</li> </ol>	<ol style="list-style-type: none"> <li>15. Wipe moisture with a dry cloth.</li> <li>16. This does not occur if the temperature and humidity are in the normal range.</li> <li>17. Fix the gap.</li> </ol>
Abnormal Noise	<ol style="list-style-type: none"> <li>18. Is the refrigerator positioned in a firm and even place?</li> <li>19. Is something in the way behind the refrigerator?</li> <li>20. Check if the evaporating tray cover is left off.</li> <li>21. Check if the cover of mechanical room in below and front sides is taken out.</li> </ol>	<ol style="list-style-type: none"> <li>22. Adjust the leveling screws. Position the refrigerator properly.</li> <li>23. Remove the objects.</li> <li>24. Replace the tray.</li> <li>25. Replace the cover.</li> </ol>
Door doesn't close well.	<ol style="list-style-type: none"> <li>26. Check if the door gasket area has become dirty or contaminated.</li> <li>27. Is the refrigerator placed in a firm and even place?</li> <li>28. Is too much food put in the refrigerator?</li> </ol>	<ol style="list-style-type: none"> <li>29. Clean the door gasket.</li> <li>30. Position the refrigerator in a firm place and adjust the leveling screws.</li> <li>31. Keep food from reaching to the door.</li> </ol>
Ice and food smell unpleasant.	<ol style="list-style-type: none"> <li>32. Check if the inside of the refrigerator becomes dirty.</li> <li>33. Did you keep fragrant foods without wrapping?</li> <li>34. It smells plastic.</li> </ol>	<ol style="list-style-type: none"> <li>35. Clean the inside of the refrigerator.</li> <li>36. Wrap fragrant food.</li> <li>37. The new refrigerator smells of plastic, but the odor will dissipate after a couple of weeks.</li> </ol>

- In addition to the items described above, refer to the following to solve the complaint.

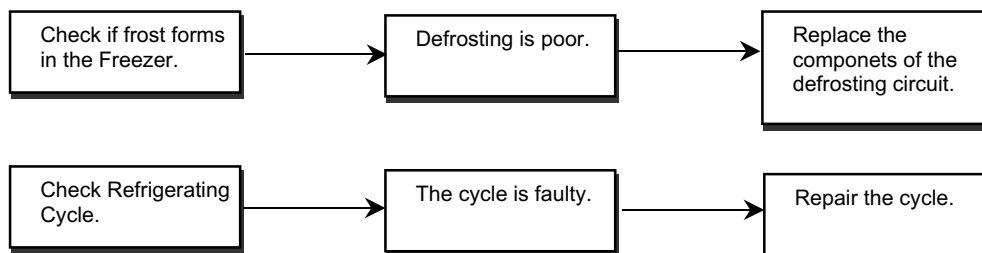

## 6-5 REFRIGERATING CYCLE

**Troubleshooting Chart**

CAUSE		REFRIGERAT CONDITION	EVAPORATOR CONDITION	TEMPERATURE OF THE COMPRESSOR	REMARKS
LEAKAGE	PARTIAL LEAKAGE	Freezer and Refrigerator don't get cold normally.	Low flowing sound of refrigerator is heard and frost forms in inlet only.	A little higher than ambient temperature.	1. A little refrigerator has leaked. 2. Refrigerator runs normally if you recharge it.
	WHOLE LEAKAGE	Freezer and Refrigerator don't get cold at all.	Flowing sound of refrigerant is not heard and frost isn't formed.	Equal to ambient temperature.	3. No discharging of refrigerant. 4. Refrigerator runs normally if you recharge it.
CLOGGED BY DUST	PARTIAL CLOG	Freezer and Refrigerator don't get cold normally.	Flowing sound of refrigerant is heard and frost forms in inlet only.	A little higher than ambient temperature	5. Normal discharging of refrigerant. 6. The capillary tube is faulty.
	WHOLE CLOG	Freezer and Refrigerator don't get cold at all.	Flowing sound of refrigerant is not heard and frost isn't formed.	Equal to ambient temperature.	7. Normal discharging of refrigerant.
MOISTURE CLOG		Cooling operation stops periodically.	Flowing sound of refrigerant is not heard and frost melts.	Lower than ambient temperature.	8. Cooling operation restarts when heating the inlet of capillary tube.
DEFECTIVE COMPRESSION	COMPRESSION	Freezer and refrigerator don't get cold.	Low flowing sound of refrigerant is heard and frost forms in inlet only.	A little higher than ambient temperature.	9. Low pressure on high side.
	NO COMPRESSION	No compressing operation.	Flowing sound of refrigerant is not heard and no frost.	Equal to ambient temperature.	No pressure of high pressure side in compressor.

**Leakage Detection**

Check for a leak which may be in the oil discharge in the compressor or in the evaporator.

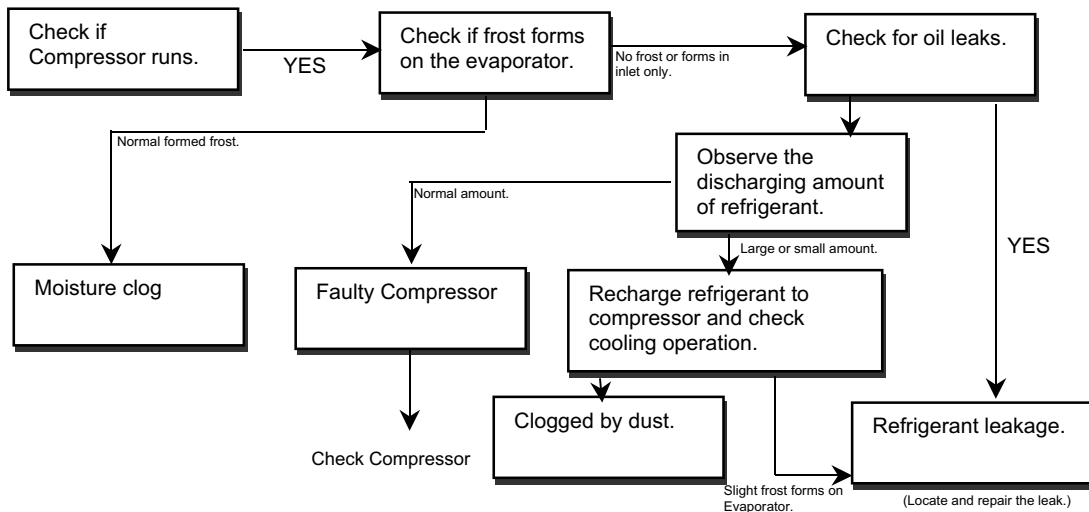

▼ General Control of Refrigerating Cycle.

NO.	ITEMS	CONTENTS AND SPECIFICATIONS	REMARKS
1	WELDING ROD	<p>1. H<sub>3</sub>O Chemical Ingredients Ag: 30%, Cu: 27%, Zn: 23%, Cd: 20% Brazing Temperature: 710 840 C</p> <p>2. BCuP<sub>2</sub> Chemical Ingredients Cu: About 93% P: 6.8 % Rest: within 0.2% Brazing Temperature: 735 840 C</p>	<p>1. Recommended H34 containing 34% Ag in the Service Center.</p>
2	FLUX	<p>Ingredients and Preparation:</p> <p>Borax 60% Fluoridation Kalium: 35% Water: 5%</p>	
3	DRIER ASSEMBLY	<p>Assemble the drier within 30 minutes after unpacking. Keep the unpacked drier at the temperature of 80 100 C</p>	<p>2. Don't store the drier outdoors, because humidity damages it.</p>
4	VACUUM	<p>1. When measuring with pirant Vacuum gauge of charging M/C, vacuum degree is within 1 Torr. 2. If the vacuum degree of the cycle inside is 10 Torr. Below for low pressure and 20 Torr. For high pressure, indicates no vacuum leakage state. 3. Vacuum degree of vacuum pump must be 0.05 Torr. below after 5 minutes. 4. Vacuum degree must be the same of the value described on item (2) above for more than 20 min.</p>	<p>3. Apply M/C Vacuum Gauge without fail. 4. Perform vacuum operation until a proper vacuum degree is built up. 5. If a proper vacuum degree is not built up, check the leakage from the Cycle Pipe line parts and Quick Coupler Connecting part.</p>
5	DRY AIR AND NITROGEN GAS	<p>The pressure of dry air must be more than 12 6Kg/cm<sup>2</sup>. Temperature must be more than -20 -70 C. Keep the pressure to 12 6Kg/cm<sup>2</sup> also when substituting dry air for Nitrogen gas.</p>	
6	NIPPLE AND COUPLER	<p>1. Check if gas leaks with soapy water. 2. Replace Quick Coupler in case of leakage.</p>	<p>6. Check if gas leaks from connecting part of coupler.</p>
7	PIPE	<p>1. Put all joint pipe in a clean box and cover tightly with the lid so dust or humidity do not contaminate.</p>	

# 7. MICOM Function & Circuit

---

## 7-1 FUNCTION

### 7-1-1 FUNCTION

1. When the appliance is plugged in, it is set to Medium. Each time the button is pushed, it cycles through Medium → Medium/High → High → Low → Medium/Low → Medium.
2. When the power is initially applied or restored after a power failure, it is automatically set to Medium.

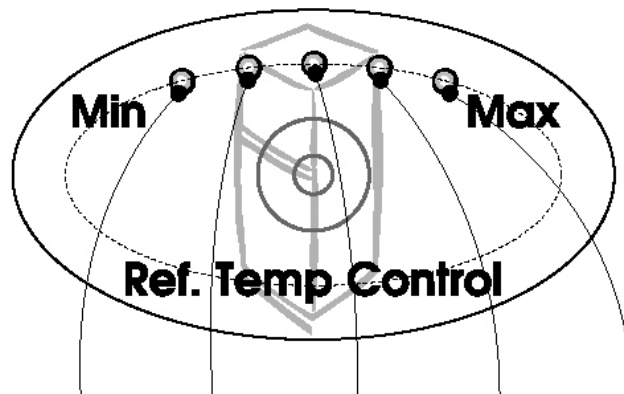

Temperature Control	Low	Medium Low	Medium	Medium High	High
TEMP F ( C )	46.4 (8)	39.2 (4)	37.4 (3)	34.7 (1.5)	30.2 (-1)
ROOM	REFRIGERATOR				

## 7-1-2 DEFROSTING

1. The defrosting is performed each time when the total running time of the compressor reaches 10 hours.
2. After the power is turned on (or restored after a power failure), the defrosting starts when the total running time of the compressor reaches 4 hours.
3. When the temperature of the defrosting sensor reaches 13 °C or above, the defrosting stops. If the temperature does not reach 13 °C in 2 hours after the defrosting starts, the defrosting error code is displayed. (Refer to 7-1-4 Error Diagnostic Mode).
4. With the defective defrosting sensor (cut or short-circuited wire), the defrosting will not be performed.

## 7-1-3 SEQUENTIAL OPERATION OF ELECTRIC COMPONENTS

The electric components, such as the compressor, defrosting heater, and cooling fan, starts sequentially to avoid noise and damage to the part which may result from the simultaneous start of various components on turning the power on or after the completion of a test.



Condition of Operation		Operating Sequence	
When the power is turned on	If the temp of the defrosting sensor is 25 °C or above (For the initial use after the purchase or grounding)	POWER ON	in 0.5 sec → COMP & COOLING FAN ON
	If the temp of the defrosting sensor is below 25 °C (After a power failure or SVC)	POWER ON	in 0.5 sec → DEFROSTING HEATER ON in 10 sec → DEFROSTING HEATER OFF in 0.5 sec → COMP & COOLING FAN ON





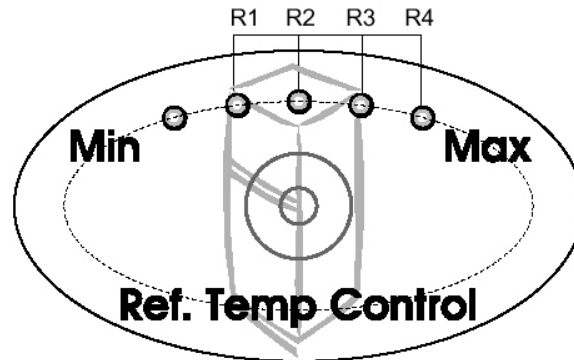







## 7-1-4 ERROR DIAGNOSTIC MODE

1. The error diagnostic mode indicates when a fault may affect the performance of the product occurs while operating the product.
2. Even if a function control button is pushed when an error occurs, the function will not be performed.
3. When the error is cleared while the error code is displayed due to a fault, the refrigerator returns to the normal condition (Reset).
4. The error code is displayed by the refrigerator temperature indication LED on the display of the refrigerator while the remaining LEDs are off.



 : ON   
  : OFF   
  : NORMAL

NO	Error	Error Code Display				Cause	State of Operation with Error	
		R1	R2	R3	R4		Comp / Cooling fan	Defrosting heater
1.	Faulty refrigerator(R) sensor (on the control box of the refrigerator)	●		●	●	Cut or short-circuited wire of refrigerator sensor	15 min ON/ 15 min OFF	
2.	Faulty defrosting sensor	●	●		●	Cut or short-circuited wire of defrosting sensor		No defrosting
3.	Defrosting failure					Cut or disconnected wire of defrosting heater or temperature fuse(indicated at least 4 hours later after the error occurs)		

## 7-2 PCB FUNCTION

### 7-2-1 POWER CIRCUIT

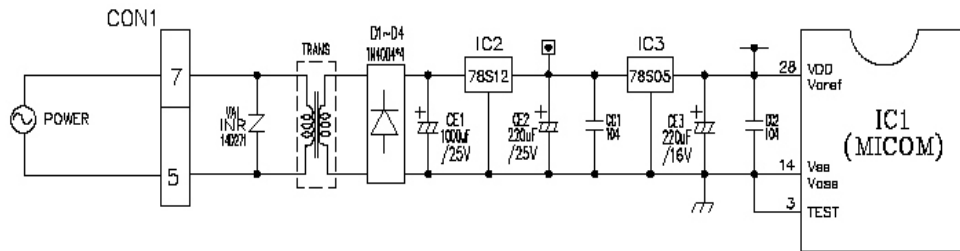

The second part of the Transformer is composed of the power supply for the display and relay drive (12 Vdc) and for the MICOM and IC (5 Vdc).  
The voltage for each part is as follows:

PART	VA 1	CE 2	CE3
VOLTAGE	127 Vac	12 Vdc	5 Vdc

VA1 prevents overvoltage and noise. When 175 V or higher power is applied, the inside elements are short-circuited and broken, resulting in the blowout of the fuse in order to protect the elements of the secondary part of the Transformer.

---

## 7-2-2 OSCILLATION CIRCUIT

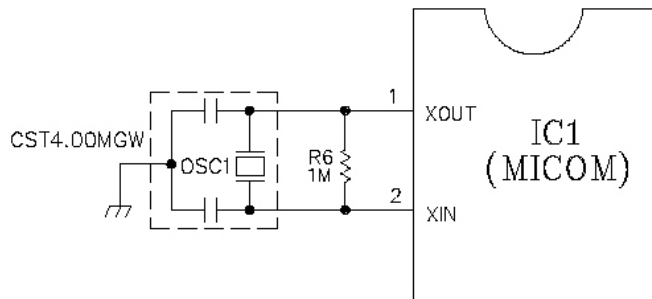

This circuit is to generate the base clock for calculating time and the synchro clock for transmitting data to and from the inside logic elements of the IC1 (MICOM). Be sure to use the exact replacement parts since the calculating time by the IC1 may be changed or it will not work if the OSC1 SPEC is changed.

## 7-2-3 RESET CIRCUIT

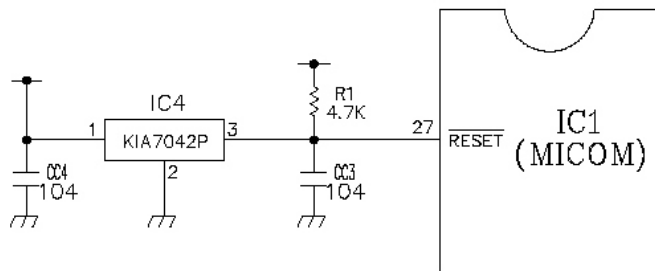

The reset circuit is for allowing all the functions to start at the initial conditions by initializing various parts including the RAM inside the MICOM (IC1) when the power is initially supplied or the power supply to the MICOM is restored after a momentary power failure. For the initial 10 ms of power supply, LOW voltage is applied to the MICOM RESET terminal. During a normal operation, 5 V is applied to the RESET terminal. (If trouble occurs in the RESET IC, the MICOM will not work).

## 7-2-4 LOAD DRIVE CIRCUIT

### 1. Load Drive Condition Check

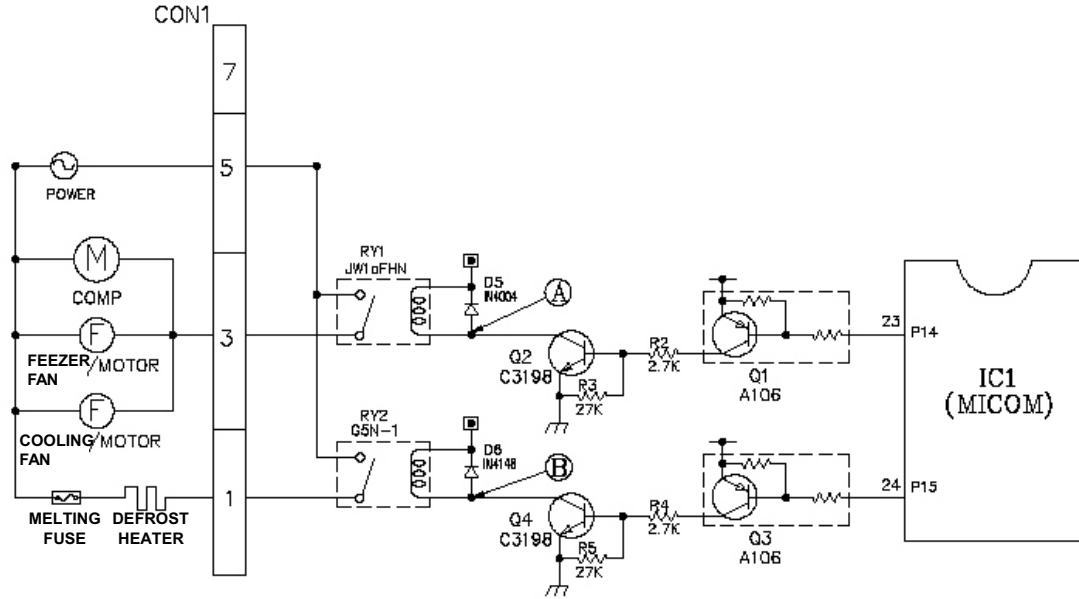

Load Type	Compressor, Freeze Fan Motor	Defrosting Heater
Measurement Location	Ⓐ	Ⓑ
Condition	ON	1 V or below
	OFF	12 V

## 7-2-5 TEMPERATURE SENSOR CIRCUIT

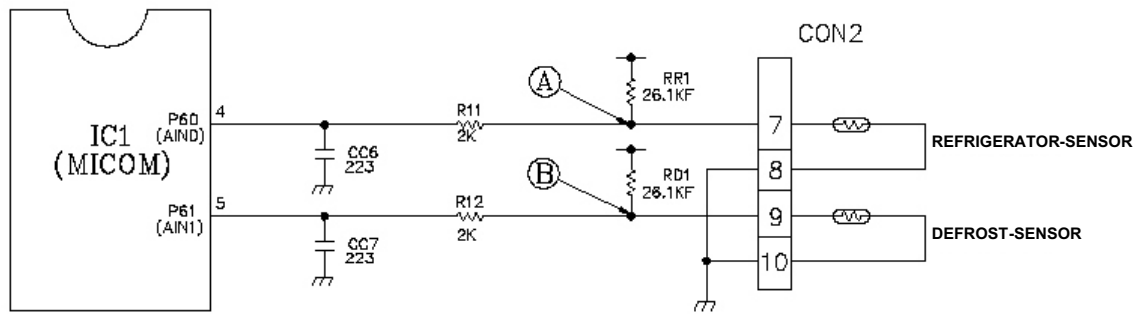

The upper CIRCUIT reads REFRIGERATOR temperature and DEFROST - SENSOR temperature for defrosting into MICOM. OPENING or SHORT state of each TEMPERATURE SENSOR are as follows:

SENSOR	CHECK POINT	NORMAL (-30 -50)	SHORT-CIRCUITED	OPEN
Refrigerator Sensor	POINT(A) Voltage	0.5 V 4.5 V	0 V	5 V
Defrosting Sensor	POINT(B) Voltage			

## 7-2-6 TEMPERATURE COMPENSATION & OVERCOOLING/UNDERCOOLING COMPENSATION CIRCUIT

### 1. Refrigerator Temperature Compensation

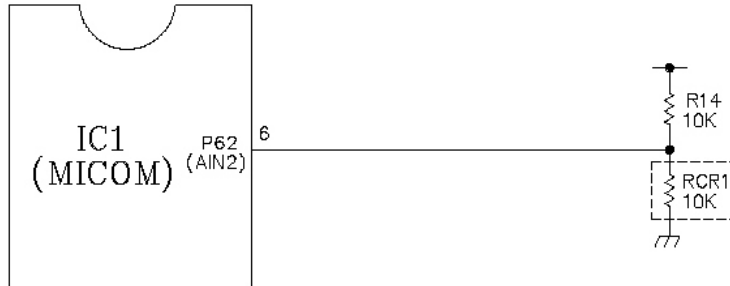

Refrigerator		Remark
Resistance (RCR1)	Temperature Compensation F ( C )	
180 K	41 (+5.0)	Compensation by raising the temperature ↑
56 K	39.2 (+4.0)	
33 K	37.4 (+3.0)	
18 K	35.6 (+2.0)	
12 K	35.24 (+1.8)	
10 K	32 ( 0 )	Standard Temperature
8.2 K	30.2 (-1.0)	Compensation by lowering the temperature ↓
5.6 K	28.4 (-2.0)	
3.3 K	26.6 (-3.0)	
2 K	24.8 (-4.0)	
470 K	23 (-5.0)	

- Table of Temperature Compensation by adjusting the resistance (Difference with the current temperature).

Example. If the refrigerator compensation resistance (RCR1) is changed from 10 K (the current resistance) to 18 K (the adjustment resistance) of the refrigerator rises 33.8 F (+1 C).

## 7.2.7 KEY BUTTON INPUT & DISPLAY LIGHT ON CIRCUIT

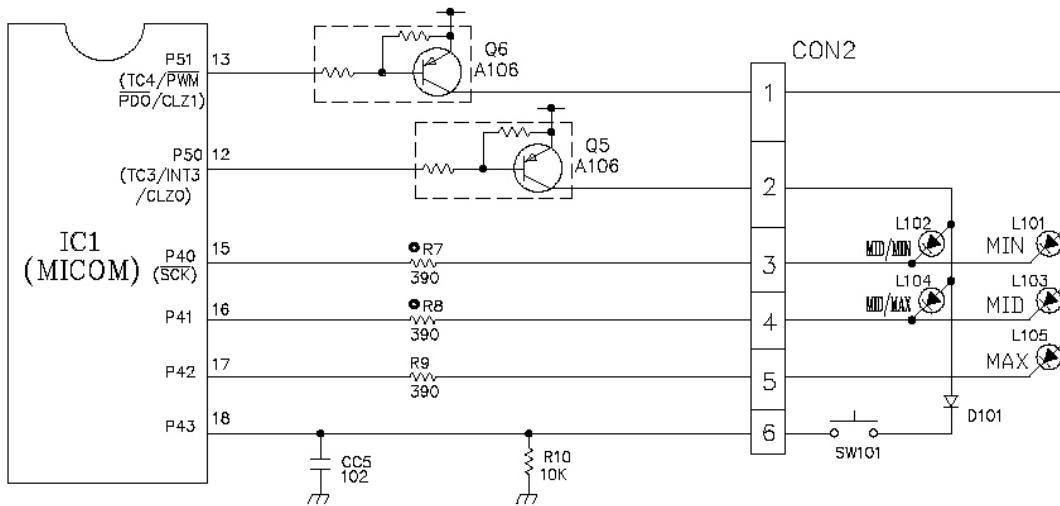

- The circuit shown above is to determine whether a function control key on the operation display is pushed and to turn on the corresponding function indication LED. The drive type is the scan type.

---

### 7-3. RESISTANCE SPECIFICATION OF SENSOR

TEMPERATURE SENSOR		RESISTANCE OF REFRIGERATOR (DEFROST) SENSOR
F	( C)	
-4	-20	77 K
5	-15	66 K
14	-10	47.3 K
23	-5	38.4 K
32	0	30 K
41	+5	24.1 K
50	+10	19.5 K
59	+15	15.9 K
68	+20	13 K
77	+25	11 K
86	+30	8.9 K
104	+40	6.2 K
122	+50	4.3 K

1. The resistance of SENSOR HAS 5% common difference.
2. Measure the resistance of SENSOR after leaving it over 3 minutes in measuring temperature. This postponing is necessary because of perceiving speed.



## 7-4. TROUBLE SHOOTING

\* Replace the PWB when there's no trouble after checking the contents of trouble.

CLASSIFICATION	STATE OF TROUBLE	POINTS TO CHECK	CHECKING METHOD	CONTENT	REMEDY
POWER SOURCE	At the DISPLAY LED OFF. DISPLAY LED represents abnormal operation.	<ol style="list-style-type: none"> <li>1. FREEZER/REFRIGERATOR. LAMP is dim.</li> <li>2. The connection of MAIN PWB CONNECTOR.</li> </ol>	<p>FREEZER/REFRIGERATOR door open. Verify the correct bulb is used. Check the connector.</p>	POWER SOURCE is incorrect. Is the voltage correct? connector connection is poor. Transformer Fuse open.	<p>Certify Fuse. Certify outlet voltage. Use boosting Transformer. Reconnect CONNECTOR. Replace Transformer</p>
				<ol style="list-style-type: none"> <li>1. Does compressor operate?</li> </ol>	COMPRESSOR lock or blocked. OLP or PTC is defective. COMPRESSOR RELAY is defective. CONNECTING WIRE is defective.
COOLING	1. NO COOLING	<ol style="list-style-type: none"> <li>2. Does refrigerant leak.</li> </ol>	<p>Measure the amount of frost on Evaporator and the surface temperature of condenser pipe.</p>	Refrigerant leakage.	Repair the leak and recharge the refrigerant.
			<ol style="list-style-type: none"> <li>1. Does FAN MOTOR operate?</li> </ol>	<p>FAN MOTOR is defective. DOOR LINER contact. CONNECTING WIRE is defective.</p>	<p>Replace FAN MOTOR. Replace DOOR LINER. Verify MOTOR and the connection of the black wire of MAIN PWB CONNECTOR (CON1).</p>
			<ol style="list-style-type: none"> <li>2. Is DEFROSTING normal?</li> </ol>	<p>Certify the amount of frost on evaporator.</p>	Poor DEFROSTING.
		<ol style="list-style-type: none"> <li>3. Is SENSOR normal?</li> </ol>	<p>Check the SENSOR resistance in the refrigerator.</p>	<p>SENSOR RESISTANCE is incorrect.</p>	Replace SENSOR.
	1. FREEZER TEMPERATURE is too warm.				

<b>CLASSIFICATION</b>	<b>STATE OF TROUBLE</b>	<b>POINTS TO CHECK</b>	<b>CHECKING METHOD</b>	<b>CONTENT</b>	<b>REMEDY</b>
POOR COOLING	REFRIGERATOR TEMPERATURE is too warm.	1. Is FREEZER TEMPERATURE normal? 2. Does the FAN MOTOR blow enough cool air?	See if FREEZER TEMPERATURE is too warm. Check the amount and speed of cool air being supplied inside the refrigerator.	FAN MOTOR is poor. AIR FLOW blocked. EVAPORATOR frozen.	Be sure door closes. Replace FAN MOTOR. Remove Impurities. See POOR DEFROSTING.
POOR DEFROSTING	NO DEFROSTING.	1. Does HEATER emit heat?	Check the main PWB.	HEATER disconnection. TEMPERATURE FUSE disconnection. Poor Connection. DEFROST SENSOR is defective. HEATER RELAY is defective.	Replace HEATER. Replace TEMPERATURE FUSE. Check evaporator connection and wire of MAIN PWB CONNECTOR. Replace DEF-SENSOR. Replace RY2 of MAIN PWB.
		2. Is the DRAIN PIPE blocked?	Check DRAIN PIPE.	DRAIN PIPE is blocked.	Remove ice and impurities. Check HEATER PLATE.
		3. Does ice remains after DEFROSTING?	Check the attachin of DEFROST-SENSOR. Check the gap in the door gasket.	Attachment is incorrect. DOOR sealing is incorrect.	Reassemble DOOR. Replace GASKET.

7-4 MAIN PWB ASSEMBLY AND PARTS LIST.  
 7-4-1 MAIN PWB ASSEMBLY.

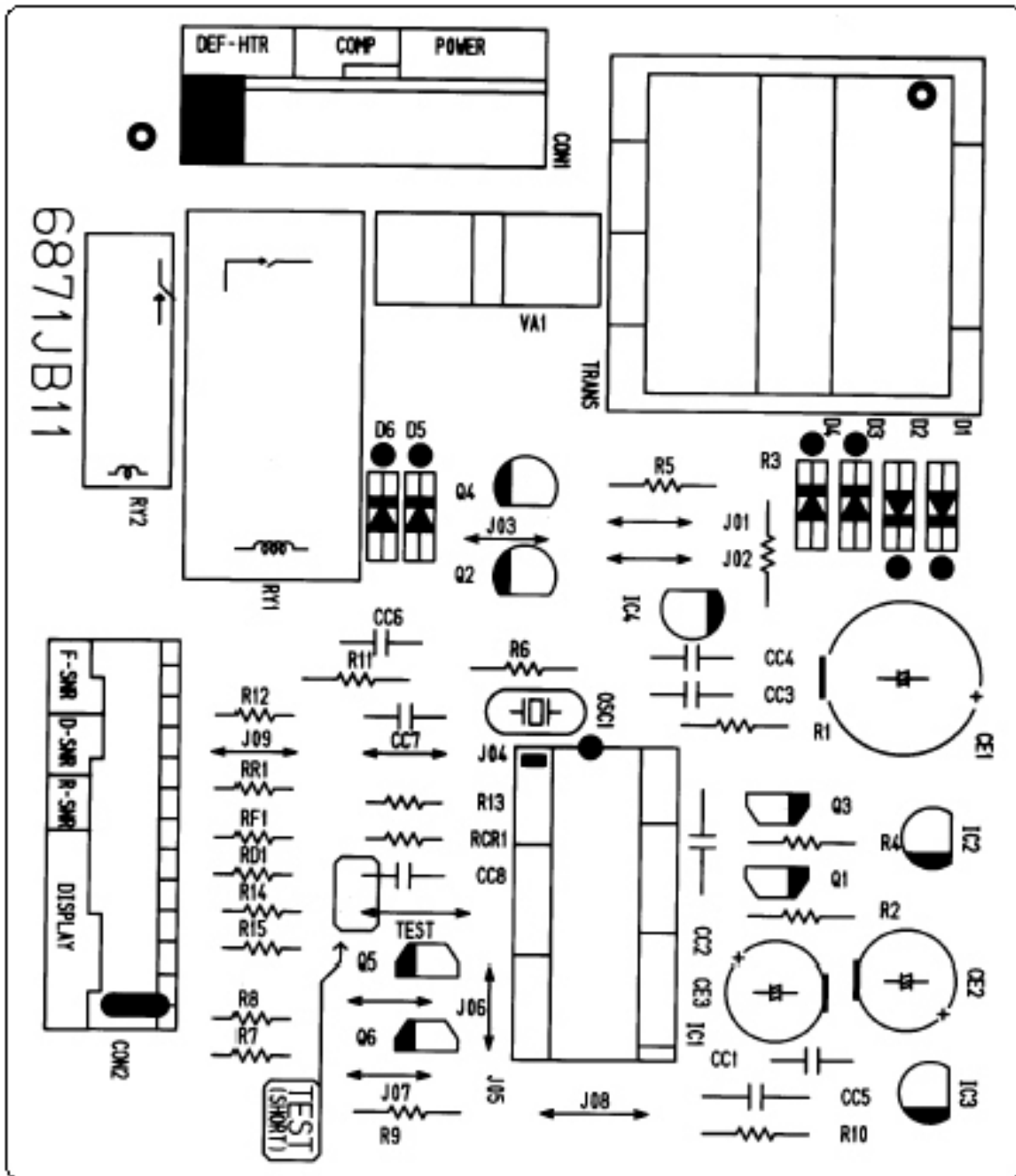







## 7.5 PWB DIAGRAM

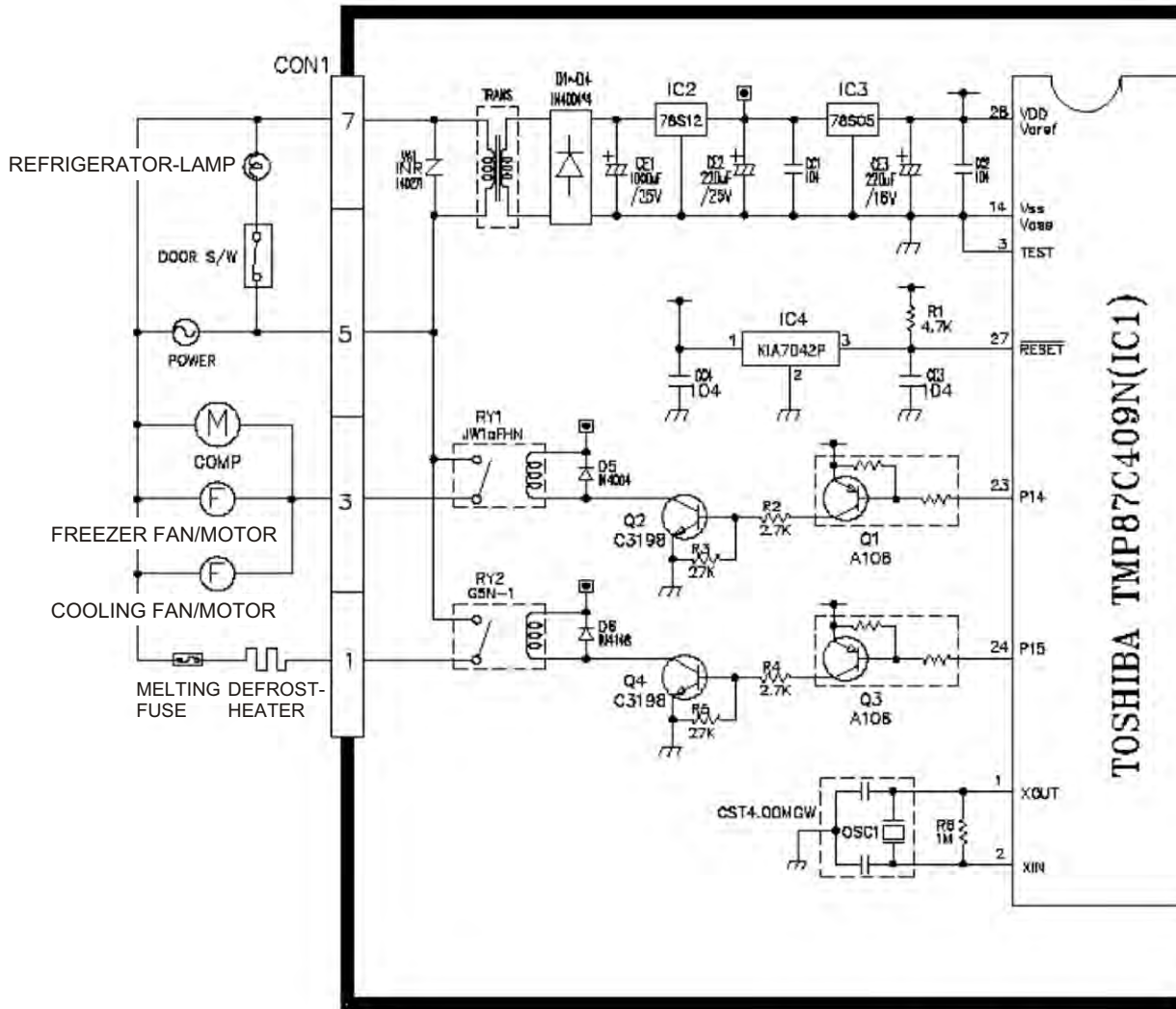

CIRCUIT DIAGRAM

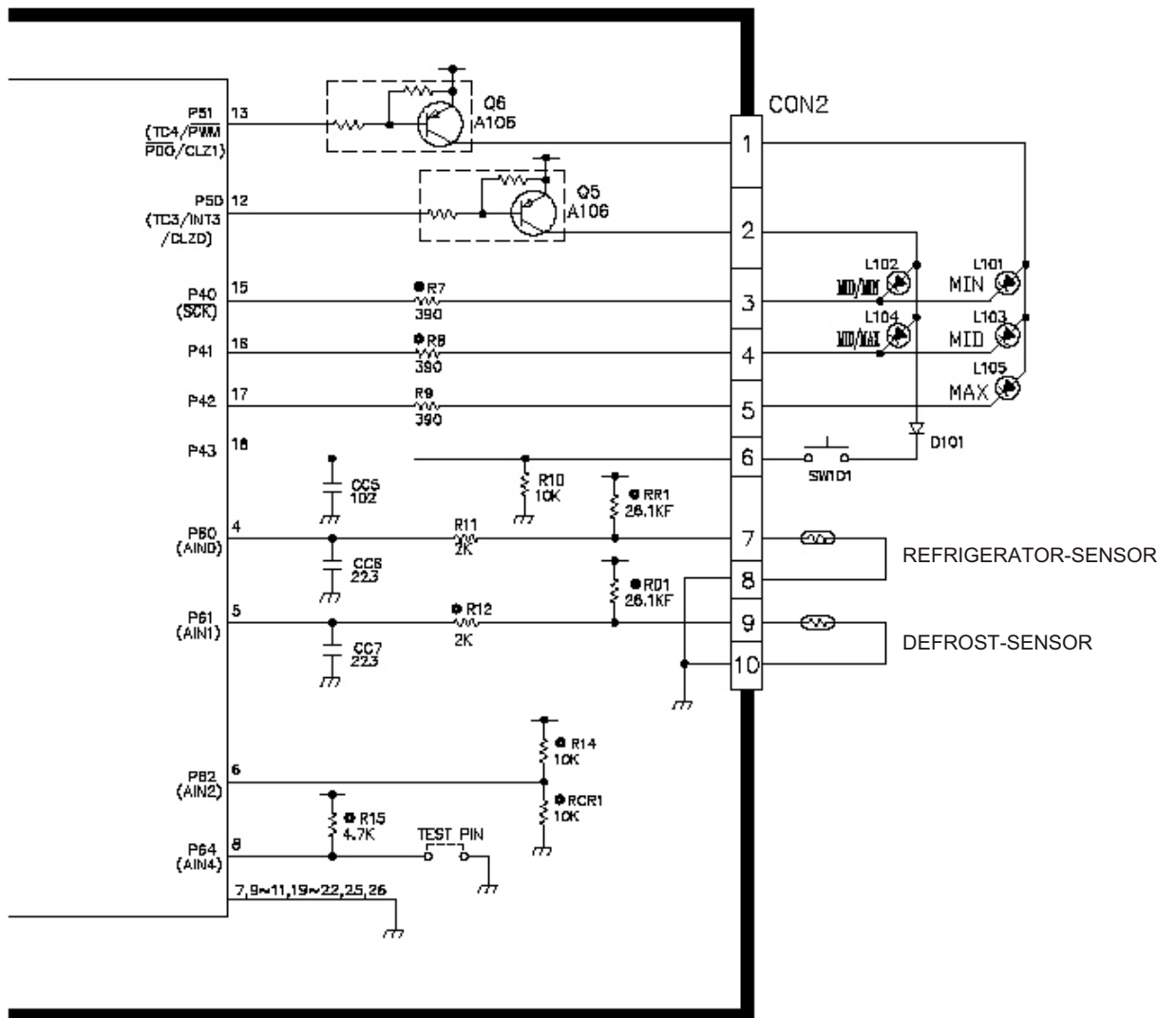



# 8. Exploded View

The parts of refrigerator and the shape of each part may vary by market area.  
 Capacitors and fuse are optional parts.  
 Optional parts:

- 1) Freezer Shelf
  - Plastic : 149A
  - Steel : 136C, 136D
- 2) Ice Maker
  - Twist : 110B, 125A, 125H, 131A
  - Standard : 125J
- 3) Refrigerator Shelves
  - Plastic : 149C
  - Steel : 136A, 136B, 149D

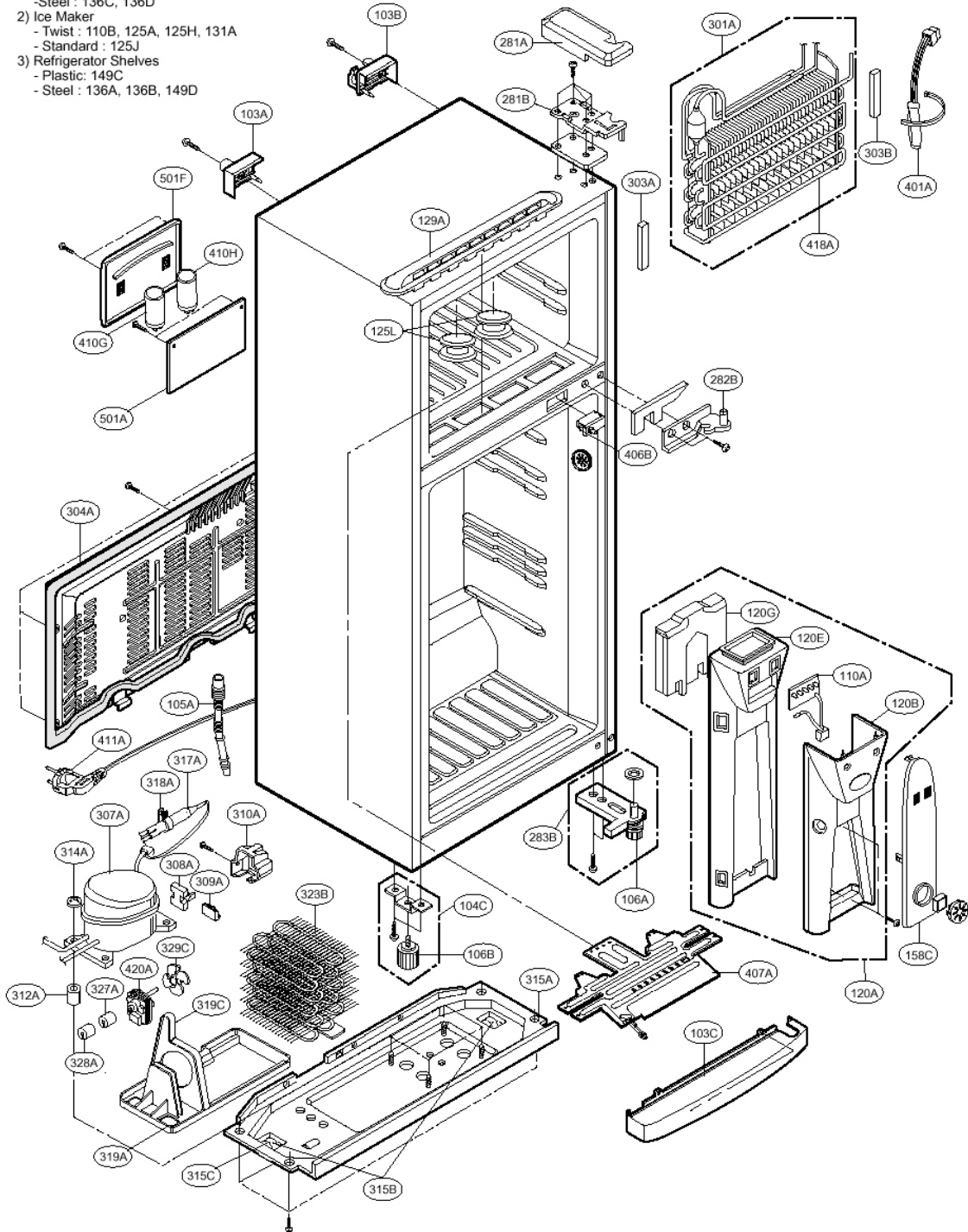

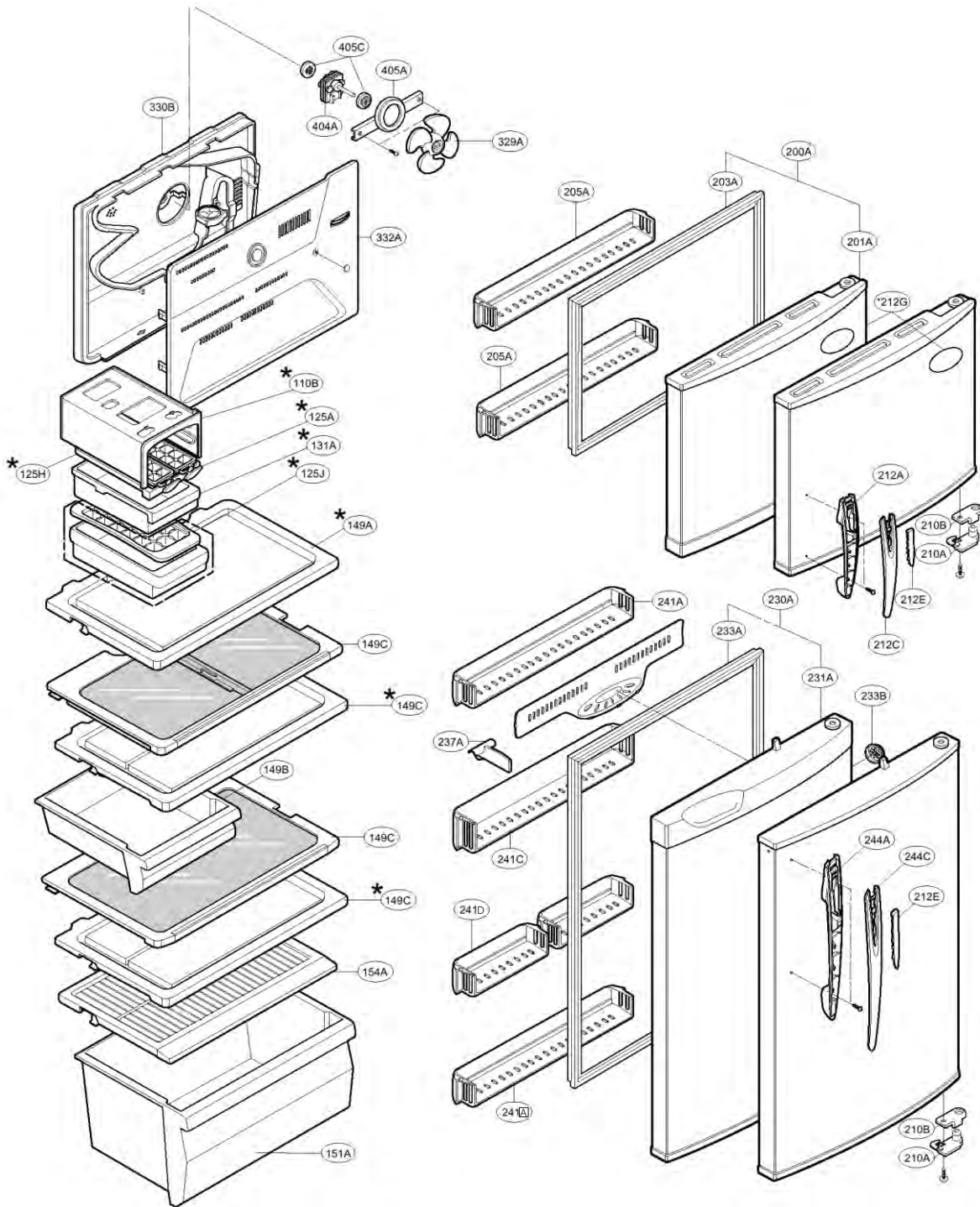

# 9. Service parts list

Loc.	Descripción	11Ft <sup>3</sup>	
		GR-382R Part Number	LRTP1231W Part Number
103A	HANDLE,BACK	3650JJ2003A	3650JJ2003B
103B	HANDLE,BACK	3650JJ2003E	3650JJ2003F
104C	LEG ASSEMBLY	4981JA3006A	4981JA3006A
105A	DRAIN,PIPE-Z	5250JA2009A	5250JA2009A
106A	ADJUSTABLE LEG	3J04686A	3J04686A
106B	ADJUSTABLE LEG	3J04686A	3J04686A
110A	PWB(PCB) ASSY,DISPLAY	6871JB2036A	6871JB2036A
110B	ICE TRAY GUIDE	4974JJ1003A	4974JJ1003A
	REFRIGERATOR CONTROL BOX	4995JJ1001E	<b>4995JJ1001F</b>
120A	ASSEMBLY		
120B	REFRIGERATOR CONTROL BOX COVER	4994JJ1001A	<b>4994JL1001A</b>
120E	DUCT,INSULATION	5208JJ1006A	5208JJ1006A
120G	DUCT,INSULATION	5208JJ1005A	5208JJ1005A
125A	ICE TRAY	3390JJ1003A	3390JJ1003A
125H	ICE TRAY SUPPORTER	4980JJ1001A	4980JJ1001A
125L	ICE TRAY HOLDER	4930JJ3001A	4930JJ3001A
129A	DUCT GUIDE	4974JJ1001A	4974JJ1001A
131A	ICE BIN	5074JJ1001A	5074JJ1001A
149A	FREEZER SHELF	5026JJ1001B	5026JJ1001B
149B	MEAT TRAY	3390JJ1002A	3390JJ1002A
149C	REFRIGERATOR SHELF ASSEMBLY	5027JJ2001A	5027JJ2003A
149E	REFRIGERATOR SHELF ASSEMBLY	5027JJ2002A	5026JJ1002A
151A	VEGETABLE TRAY	3390JJ1001A	3390JJ1001A
154A	VEGETABLE TRAY COVER	3550JJ1003B	3550JJ1003B
158C	LAMP COVER	3550JJ1004B	3550JJ1004A
200A	FREEZER DOOR ASSEMBLY	3581JJ8009B	<b>3581JJ8001D</b>
201A	FREEZER DOOR FOAM ASSEMBLY	5433JJ0011A	<b>5433JJ0003D</b>
203A	FREEZER DOOR GASKET ASSEMBLY	4987JJ1001A	4987JJ1001A
205A	DOOR BASKET	5004JJ1001B	5004JJ1001B
210A	DOOR STOPPER	4620JJ2004A	4620JJ2001A
210B	STOPPER GUIDE	4974JA3031A	J325-00033A
212G	NAME PLATE,P(H)	4140JD1020P	<b>4140JD1020B</b>
230A	REFRIGERATOR DOOR ASSEMBLY	3581JJ8010A	3581JJ8002D
231A	REFRIGERATOR DOOR FOAM ASSEMBLY	5433JJ0012B	5433JJ0005B
233A	REFRIGERATOR DOOR GASKET ASSEMBLY	4987JJ1001C	4987JJ1001B
241A	DOOR BASKET	5004JJ1004B	5004JJ1004B
241B	DOOR BASKET	5004JJ1002B	5004JJ1002B
241C	DOOR BASKET	5004JJ1003B	5004JJ1003B
241D	DOOR BASKET	5004JJ1005B	5004JJ1005B
281A	HINGE COVER	3550JJ2011A	3550JJ2004B

Loc.	Descripción	11Ft <sup>3</sup>	
		GR-382R	LRTP1231W
281B	UPPER HINGE ASSEMBLY	4775JA3015C	4775JA2001D
282B	CENTER HINGE ASSEMBLY	4775JA3009B	4775JA3009A
283B	LOWER HINGE ASSEMBLY	4775JA2020A	4775JA2023B
301A	EVAPORATOR ASSY	5421JA2359B	5421JA2359A
303A	SPACER,INSULATION	4826JJ2001A	4826JJ2001A
303B	SPACER ASSY	4827JJ3001A	4827JJ3001A
304A	MECHANICAL AREA COVER	3551JJ2002A	3551JJ2002A
307A	COMPRESSOR ASSEMBLY	2521JA1006A	2521C-B5602
308A	PTC ASSEMBLY	6748JA3001A	6748C-0004D
309A	OLP	6750JA3001A	6750C-0005D
310A	PTC COVER	3550JA2158A	3550JA2087B
312A	BUSHING	5040JA3044A	5040JA3021A
314A	COMPRESSOR BUSHING	4J03277A	4J03277A
315A	COMP BASE ASSY,STD	3103JJ2001C	3103JJ2001A
315B	ROLLER	3J02312A	3J02312A
315C	PIN	4J04238A	4J04238A
317A	DRIER ASSY	5851JJ2002A	5851JJ2002A
318A	DRIER HOLDER	4930JJ3002A	4930JJ3002A
319A	DRIP TRAY	3390JJ0001A	3390JJ0001A
319C	FAN GUIDE	4974JJ1002A	4974JJ1002A
323B	CONDENSER ASSY,WIRE	5403JA1039A	5403JA1039A
327A	BUSHING	5040JJ3003A	5040JJ3003A
328A	BUSHING	5040JJ3002A	5040JJ3002A
329A	FAN ASSEMBLY	5901JJ1001A	5901JJ1001A
329C	FAN ASSEMBLY	5901JJ1001B	5901JJ1001B
330B	FREEZER SHROUD ASSEMBLY	4999JJ1001A	4999JJ1001A
332A	FAN GRILLE ASSEMBLY	3531JJ1001A	3531JJ1001A
401A	DEFROST CONTROL ASSEMBLY	6615JB2005C	6615JB2005A
404A	FAN MOTOR (MECHANICAL AREA)	4680JB1033B	4680JB1033D
405A	MOTOR BRACKET	4810JA3007A	4810JA3007A
405C	FAN MOTOR BUSHING	J756-00008B	J756-00008B
406B	DOOR SWITCH	6600JB1002K	6600JB1002K
407A	HEATER,PLATE	5300JB1080F	5300JB1080F
410H	CAPACITOR[M/R]	0CZZJB2003G	J513-00003C
411A	CONNECTOR ASSEMBLY	6877JK3001A	6877JK1002A
418A	HEATER,CORD	5300JB1079F	5300JB1079C
420A	MOTOR(MECH),COOLING	4680JB1017Q	4680JB1017C
501A	MAIN PWB ASSEMBLY	6871JB1115A	6871JB1115B
501F	PWB ASSEMBLY	3550JJ2001B	3550JJ2001A
604F	DEODORIZER COVER	3550JJ2002A	3550JJ2002A
155J	NAME PLATE,P(H)	4140JJ2001A	4140JJ2001A
409B	LIGHT BULB	6912JB2002J	6912JB2002J
604G	DEODORIZER	NO DEODORIZER	5986JA3007B



**LG Electronics Inc.**

P/No. 3828J8331B

