

AKIRA
makes life better

**Air Conditioner
Service Manual**

**Model:
AC-S13CG x 2**

Content

Technical specification.....	4
Performance curve.....	5
Outline & dimension of indoor unit.....	10
Outline & dimension of outdoor unit.....	11
Exploded view of indoor unit	12
Spare parts list of indoor unit.....	13
Exploded view of outdoor unit.....	14
Spare parts list of outdoor unit.....	15
Circuit Diagram	16
PCB Function Manual.....	17

TECHNICAL SPECIFICATION

Content	AC-S13CG
---------	----------

Function		Cooling	
Power supply		1Ph 220~230V-50Hz	
Capacity (BTU/h)		12000	
Rated input (W)		1195	
Rated current (A)		5.33	
Air flow (m ³ /h)		480	
Dehumidifying volume (L/h)		1.4	
EER(W/W)		2.5	
Indoor unit	Motor fan speed(r/min)	1190/1090/990	
	Output power(w)	14	
	Fan type/piece	Cross flow fan-1	
	Diameter-length(mm)	97mm x 583	
	Evaporator	Aluminum fin-copper tube	
	Row-fin distance(mm)	2-1.4	
	Working area(m ²)	0.14	
	Swing motor	MP24GA	
	Input/Power(W)	2	
	Fuse(A)	Controller 3.15A Transformer 0.2A	
	Working capacitor(uF)	1	
	Noise(dB(A))	< 40 / = 40	
	Dimension (width-height-depth)(mm)	770 x 250 x 180	
	Net weight(Kg)	8.5	
Outdoor unit	Input power	W 1179	
	Current	A 5.33	
	L.R.A.	A 29	
	Throttling method	Capillary	
	Compressor	RH207VHKC	
	Starting method	Capacitor Starting	
	Working temp.	<115°C / =115°C	
	Condenser	Aluminum fan-copper tube	
	Pipe-diameter	9.52	
	Row-fin distance (mm)	1-1.6	
	Working area	0.4	
	Fan motor speed(rpm)	48/880	
	Type-piece	Axial fan-1	
	Diameter(mm)	400	
	Defrosting method	Auto defrost	
	Noise(dB(A))	56	
	Dimension (width-height-depth) (mm)	848 x 540 x 320	
Net weight(Kg)	40		
Refrigerant charge(kg)	R22/0.8		
Connecting pipe	Length (m)	4	
	Outer diameter	Liquid pipe	6(1/4")
		Gas pipe	12(1/2")
	Max distance	Height(m)	5
		Length(m)	10

PERFORMANCE CURVE

The change relation between low pressure, operation current and temp.

Cooling operation condition: In testing, indoor and outdoor have same work condition.

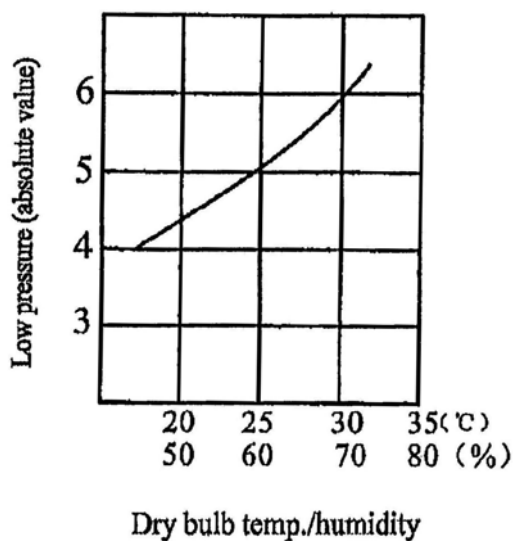

(a)

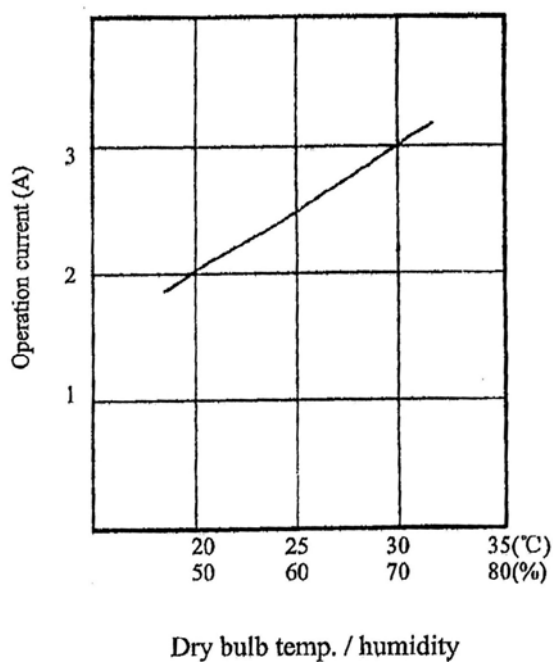

(b)

Heating operation

Indoor work condition: dry bulb temp.21 , wet bulb temp. 15.5 ° C .

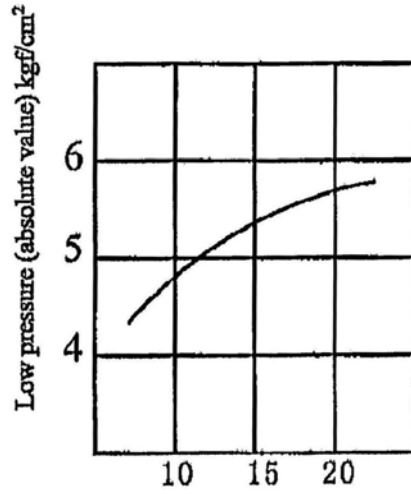

Outdoor dry bulb temp.
(c)

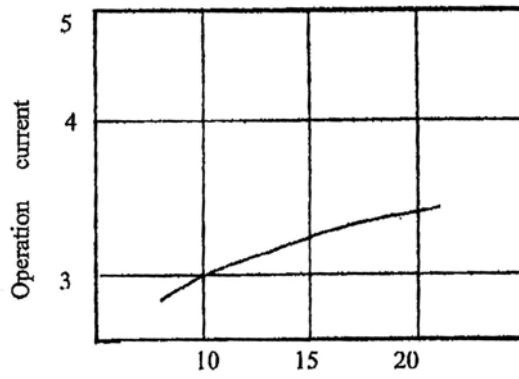

Outdoor dry bulb temp.
(d)

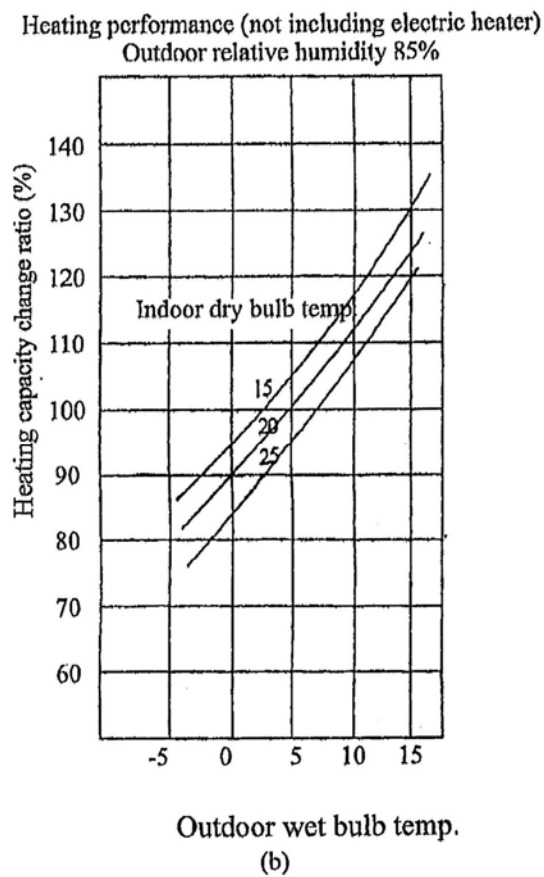
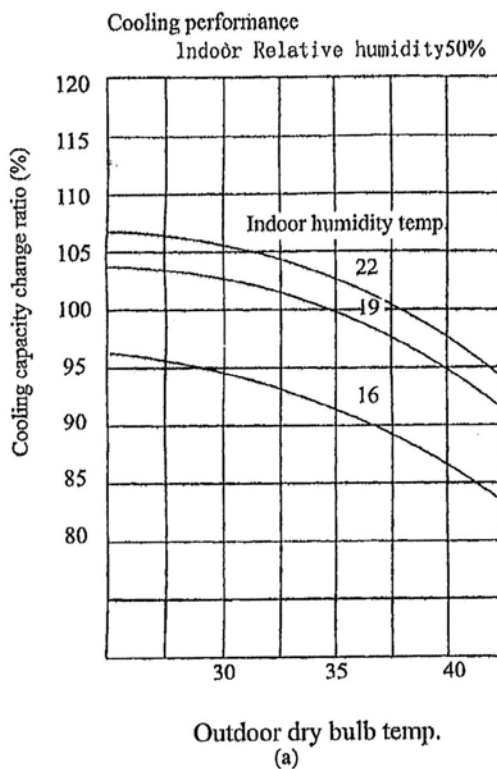

Cooling performance

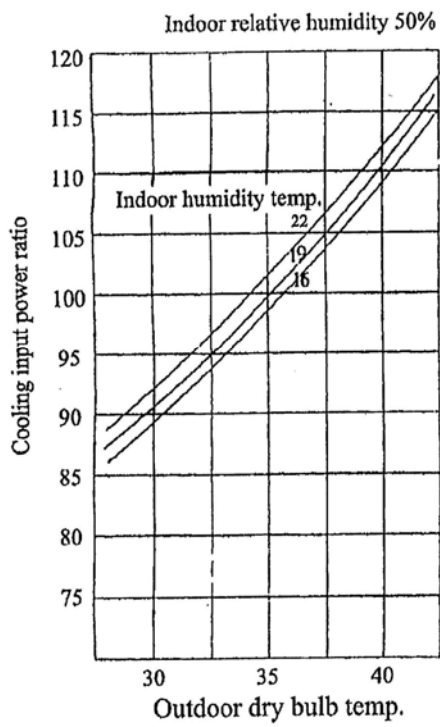

(c)

Heating performance (not including electric heater)

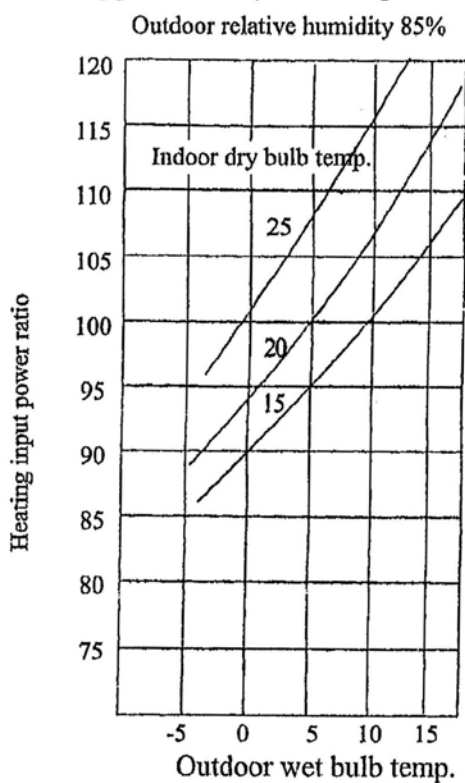

(d)

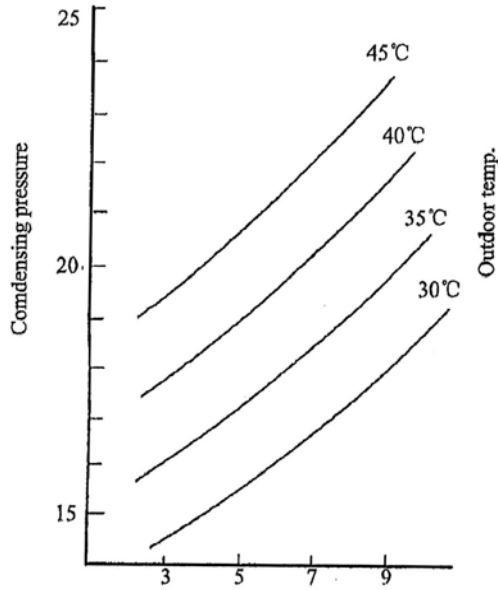

Evaporative pressure

The affection to the charging quantity by pressure under cooling work condition.

The affection to the charging quantity by pressure under cooling work condition.

(Indoor work condition: dry bulb 27°C, wet bulb 19.5°C)

(e)

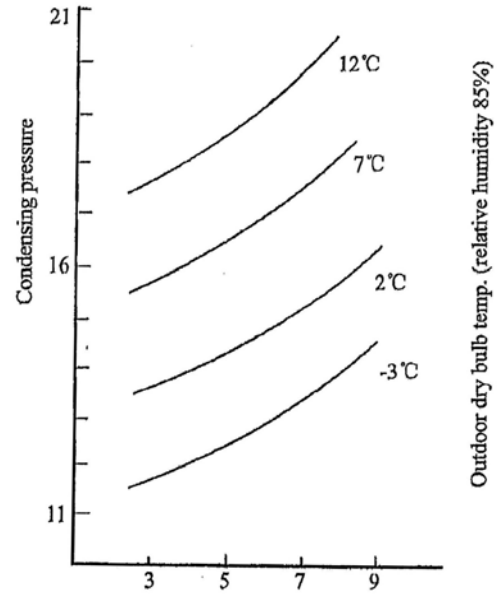

Evaporative pressure

Outdoor dry bulb temp. (relative humidity 85%)

(Indoor work condition: dry bulb 21°C)

(f)

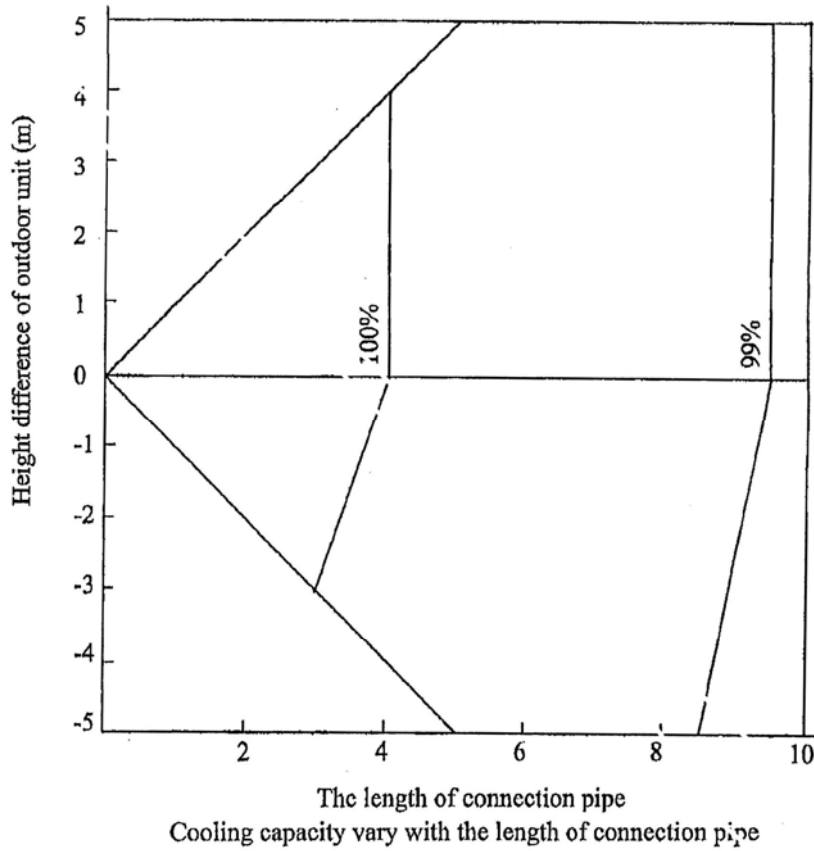

Cooling capacity vary with the length of connection pipe

OUTLINES AND DIMENSIONS OF INDOOR UNIT

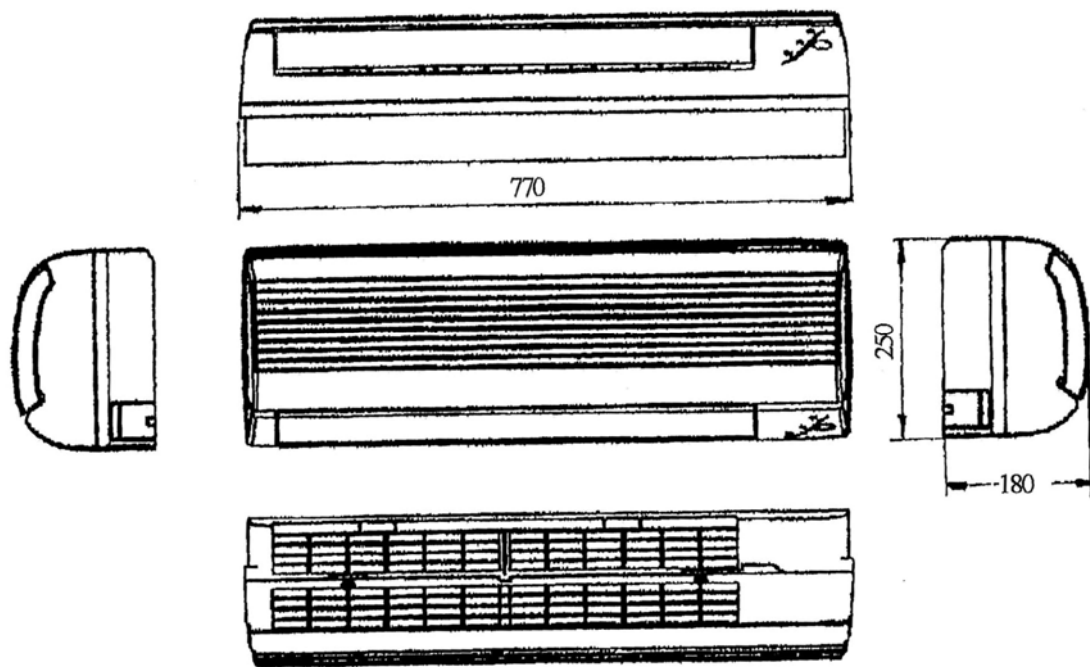

Back view

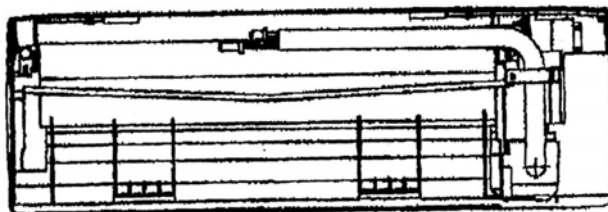

Unit:mm

Ceiling

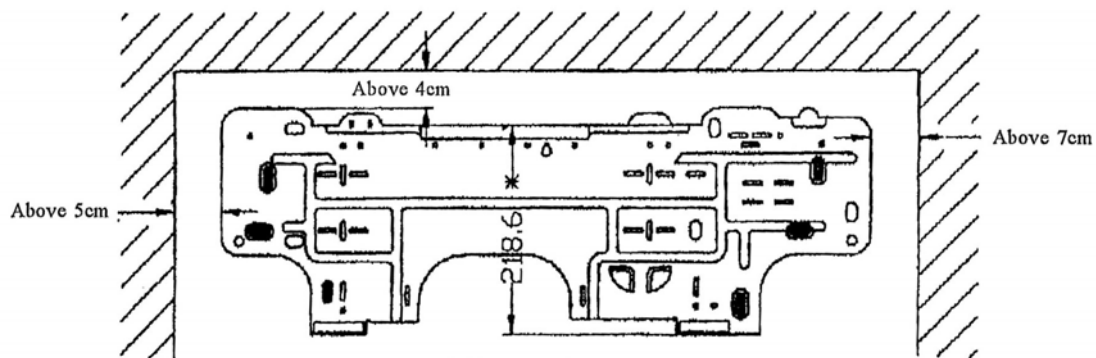

Wall-mounted frame

OUTLINES AND DIMENSIONS OF OUTDOOR UNIT

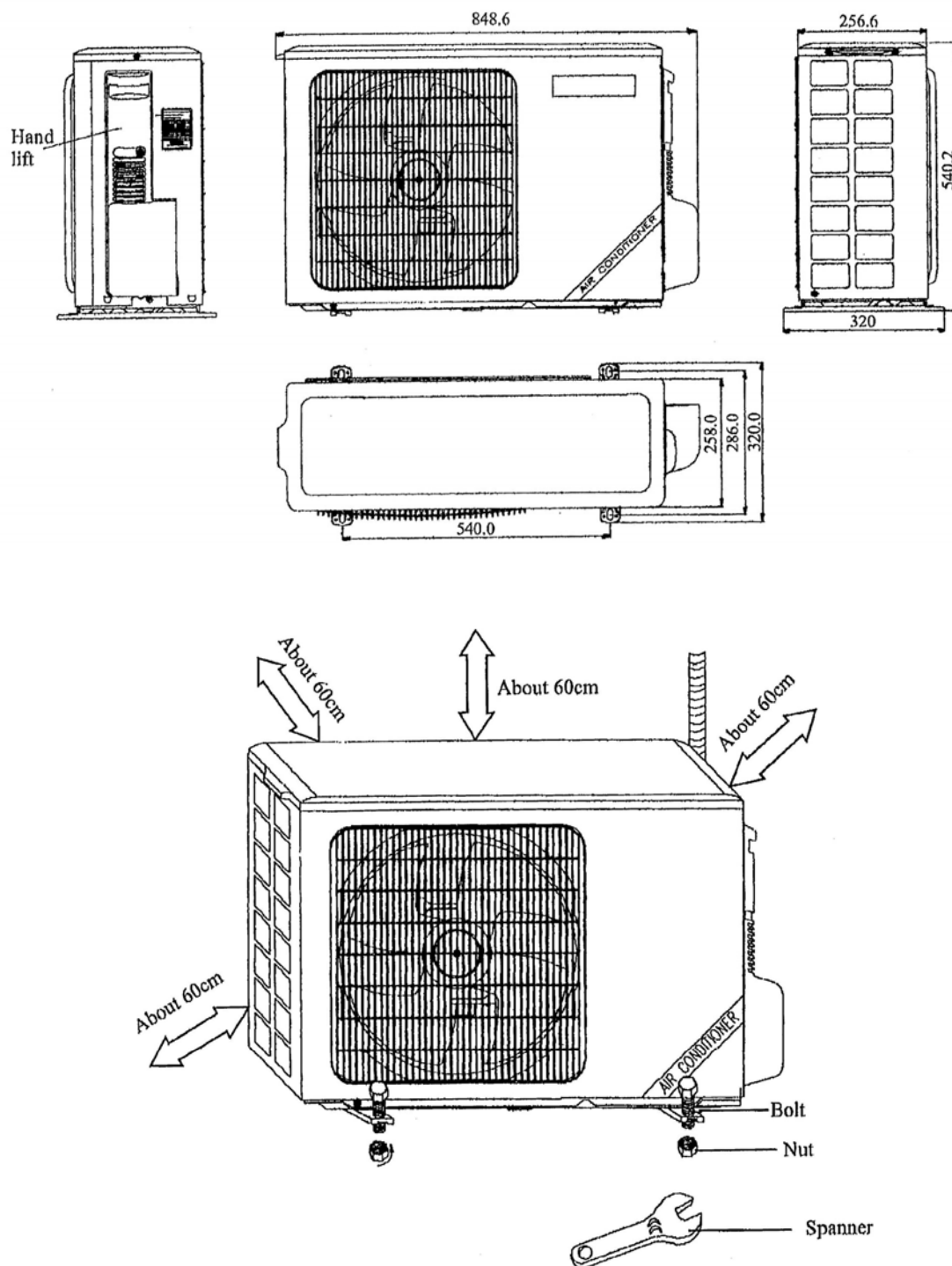

EXPLODED VIEW OF INDOOR UNIT

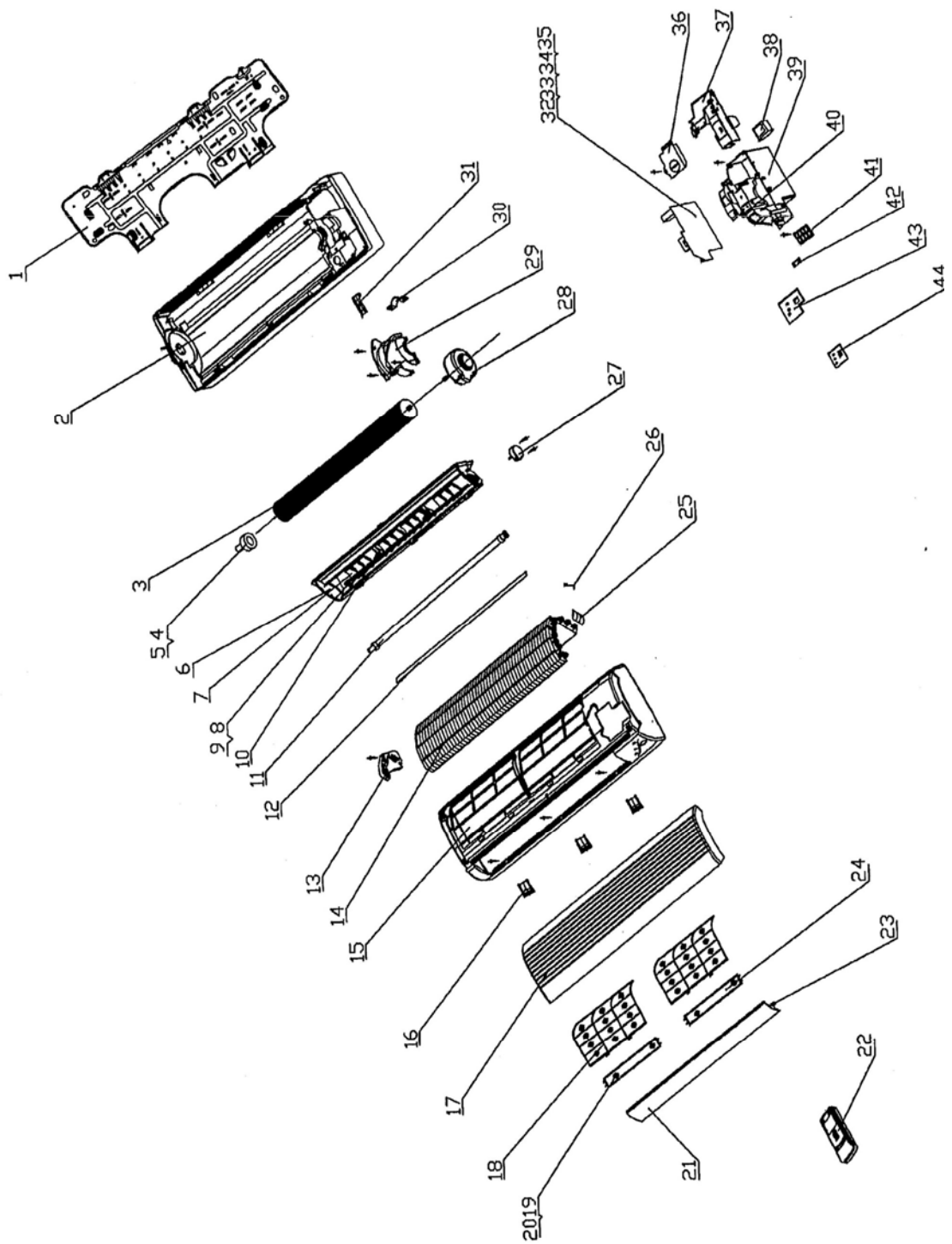

PARTS LIST OF INDOOR UNIT

No	Description	Part No	Qty
1	Wall-Mounting Frame	01252438	1
2	Rear Case	22202001	1
3	Cross Flow Fan	10352001	1
4	Fan Bearing	76512210	1
5	Ring of Bearing	76512203	1
6	Water Tray Assy	20182012	1
7	Swing Louver	10512002	12
8	Connecting Lever 1	10582002	1
9	Connecting Lever 2	10582003	1
10	Manual Lever	10582001	2
11	Drainage Pipe	05232411	1
12	Evaporator Gate	01094001	1
13	Evaporator Supporter	24212001	1
14	Evaporator Assy	01002050	1
15	Front Case Assy	20002114	1
16	Screw Cover	24252001	3
17	Front Panel	20002001	1
18	Filter	11122002	2
19	Air Cleaner holder	24222001	2
20	Air Cleaner A	11012002	1
21	Guide Louver	10512001	1
22	Remote Controller	30512505	1
23	Guide Louver Bearing	10542011	3
24	Air Cleaner B	11012003	1
25	Evaporator Pipe Cover	06122001	1
26	Sensor Insert	42020063	1
27	Stepping Motor MP24GA	15212102	1
28	Motor FN14A	15012108	1
29	Motor Clamp	26112014	1
30	Wire Clamp	71010103	1
31	Pipe Clamp	24242001	1
32	PCB 5K512	30025507	1
33	Tube Sensor	39000165	1
34	Room Sensor	39000164	1
35	Fuse 3.15A 250VAC	46010014	1
36	Electric Box Cover 2	01412007	1
37	Electric Box Cover	20102431	1
38	Transformer	43110170	1
39	Electric Box	20102001	1
40	Cable Clamp	70482001	1
41	Terminal Board T4A3A7377	42010183	1
42	Wire Clip	42012415	1
43	LED Holder	24212005	1
44	LED Board	30046015	1
45	Connection Cable	40020403	1
46	Power Cord	40020203	1

EXPLODED VIEW OF OUTDOOR UNIT

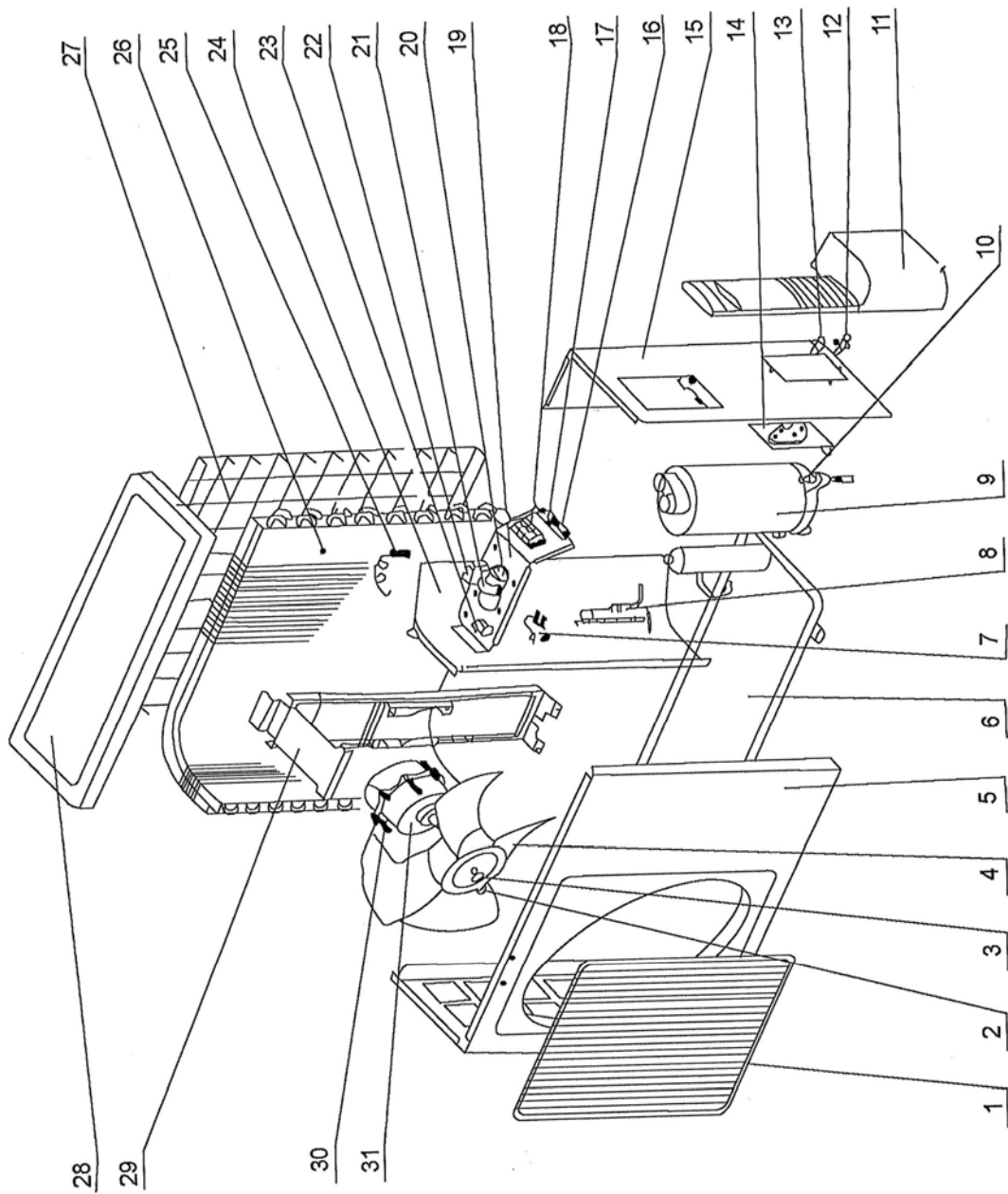

PARTS LIST OF OUTDOOR UNIT

No	Description	Part No	Qty
1	Front Grill	22413431	1
2	Nut M6	70310132	1
3	Washer 6	70410252	1
4	Axial Flow Fan	10333412	1
5	Front Plate	01533428	1
6	Metal Base	01203030	1
7	4-way Valve	-	1
8	Capillary Assy	03003030	1
9	Compressor RH207VHKC	00120082	1
10	Nut with Washer M8	70310014	3
11	Handle	26233431	1
12	Valve 1/2"	07100147	1
13	Valve 1/4"	07100120	1
14	Valve Support	01713424	1
15	Right Side Plate Assy	01302000	1
16	Wire Clamp	71010103	2
17	Insulation Gasket	70410525	1
18	Terminal Board T386A	42011241	1
19	Electric Plate	01413425	1
20	Comp Capacitor 30uF/450V	33000021	1
21	Capacitor clamp	02143401	1
22	Fan Capacitor 3uF/450V	33010027	1
23	Terminal Board 2-8	-	1
24	Isolation Sheet Assy	01233417	1
25	Tube Sensor	-	1
26	Condenser Assy	01103408	1
27	Rear grill Assy	11123402	1
28	Top cover Assy	01253261	1
29	Motor Support	01703391	1
30	Self-tapping Screw	10140165	4
31	Motor FW48A	15013036	1

CIRCUIT DIAGRAM

These circuit diagrams are subject to change without notice.
Please refer to the ones stuck on the machines.

PCB FUNCTION MANUAL

3 In 1 PCB Function manual

A. Running mode

1. Cooling
2. Dehumidifying
3. Heating
4. Auto

B. Input parameters

1. Indoor ambient temp. T_{in}
2. Evaporator tube temp. T_{eva}
3. Setting temp. T_{set}
4. Condenser tube temp. T_{con}

C. Targets

1. Indoor motor (motor)
2. Swing motor
3. Outdoor motor (single speed motor)
4. Compressor
5. Four-way reversing valve
6. Cooling, dehumidifying indicator; running indicator
7. Digital tube setting temp. indicator or timer indicator

D. Fundamental functions

Cooling mode

- 1 The running conditions and control measures
 - a. If $T_{in} > \text{or} = T_{set} + 1^{\circ}\text{C}$, the machine runs at the cooling mode. Compressor runs, outdoor motor runs at low speed, indoor fan runs at the set fan speed.
 - b. If $T_{in} < \text{or} = T_{set} - 1^{\circ}\text{C}$, the machine stops. Compressor stops first, outdoor motor stops after 15 seconds, indoor motor runs at the set fan speed.
 - c. If $T_{set} - 1^{\circ}\text{C} < T_{in} < T_{set} + 1^{\circ}\text{C}$, keep the previous state.
- 2 In this mode, the reversing valve is inactive, the temp. setting range is from 16~30°C.
- 3 Protect function
 - a. Anti-freezing function.
 - i. If compressor have run 6 minutes, and detect $T_{eva} < 0^{\circ}\text{C}$ for continuous 3 minutes, then the compressor, outdoor fan stopped, indoor fan run at the set fan speed. After 3 minutes later, it will run at the original state if $T_{eva} > \text{or} = 10^{\circ}\text{C}$.
 - b. Compressor protection
 - i. Compressor's starting interval should be more than 3 minutes no matter in whatever modes and conditions. If it's plugged in first time, the compressor does not have 3 minutes delay. When compressor is started, it will not stop within 5 minutes unless it is plugged out.
 - c. Overload protection
 - i. If it detect the system current surpass the designed 13 A for continuous 3 minutes, the machine go into fan mode, when 3 minutes passed and it detect the current no more than 13 A, it will back to original state. If it detects overloading states for 6 consecutive times, the machine stops, and must be restarted by remote controller.

Dehumidifying mode

- 1 The working conditions and control measures
 - a. If $T_{in} > T_{set} + 2^{\circ}\text{C}$, it is in cooling running, the indoor motor speed can be selected, and outdoor motor run at low speed.

- b. If $T_{\text{set}} - 2^{\circ}\text{C} < \text{or} = T_{\text{in}} < \text{or} = T_{\text{set}} + 2^{\circ}\text{C}$, it goes into dehumidifying running, the indoor motor runs at the low speed, 6 minutes later the compressor stops, another 15 seconds later the outdoor fan stops and another 30 seconds later, the indoor motor stops, 3 and a half minutes later, compressor and outdoor fan run again, indoor motor runs at the low speed, then the machine cycles the above procedures repeatedly. outdoor motor runs at the low speed.
 - c. If $T_{\text{in}} > T_{\text{set}} - 2^{\circ}\text{C}$, compressor, outdoor motor and indoor motor stop.
- 2 In this mode, the reversing valve is inactive, the temp. setting range is 16~30°C.
 - 3 Anti-freezing protection.
 - a. If $T_{\text{indoor}} > T_{\text{set}} + 2^{\circ}\text{C}$, it goes into cooling running, anti-freezing function is same with cooling mode, but the compressor must stop for 4 minutes when it goes into dehumidifying mode, compressor runs 6 minutes, if it detects $T_{\text{eva}} < 0^{\circ}\text{C}$, compressor and outdoor motor stop, indoor motor runs at low speed, after 3 minutes delay, and $T_{\text{eva}} > \text{or} = 10^{\circ}\text{C}$, it will be back to its original state.

Heating mode

- 1 The working conditions and control measures
 - a. If $T_{\text{in}} < \text{or} = T_{\text{set}} + 2^{\circ}\text{C}$, it goes into heating mode, reversing valve, compressor and outdoor motor all work in the same time, indoor fan will run at the same procedures with anti cool air function.
 - b. If $T_{\text{in}} > \text{or} = T_{\text{set}} + 4^{\circ}\text{C}$, compressor stops first, 15 seconds later, outdoor motor stops, but reversing valve keeps working, indoor motor runs at the procedures of blowing surplus heat.
 - c. If $T_{\text{set}} + 2^{\circ}\text{C} < T_{\text{indoor}} < T_{\text{set}} + 4^{\circ}\text{C}$, keep the previous running state.
- 2 In this mode, the temperature setting range is 16~30°C.
- 3 The working conditions of auxiliary electric heater.
 - a. In heating mode, when compressor is working, indoor motor runs at high speed and middle speed. If it detects $T_{\text{eva}} < 50^{\circ}\text{C}$ for continuous 8 seconds and $T_{\text{indoor}} < \text{or} = 25^{\circ}\text{C}$, electric heater will work, if compressor stop or indoor motor runs at low speed or $T_{\text{eva}} 54^{\circ}\text{C}$ or $T_{\text{indoor}} 28^{\circ}\text{C}$ or 10 seconds before defrosting, the electric heater will stop.
- 4 Protections
 - a. Anti cool air
 - i. When the machine starts heating and $T_{\text{eva}} > \text{or} = 22^{\circ}\text{C}$, indoor motor runs at low speed, and swing motor makes the louver at the horizontal position, if $T_{\text{eva}} > \text{or} = 40^{\circ}\text{C}$ or compressor has run 2 minutes, indoor motor and swing motor will run at the set speed.
 - b. Anti high temp.
 - i. In heating mode, if it detects $T_{\text{eva}} 56^{\circ}\text{C}$ (58 can be selected), outdoor motor will stop (in this period it will not detect the defrosting temp.). If $T_{\text{eva}} 52^{\circ}\text{C}$, outdoor motor will be back running (it will not detect defrosting temp. in the first 5 seconds).
 - c. Blowing surplus heat
 - i. In heating mode, when set temp is reached, comp. stops first, 15 seconds later outdoor fan stops, indoor motor blows 90 seconds (60 seconds can be selected) at low speed, swing motor makes the louver at the horizontal position.
 - d. Compressor's protection is same with the one in cooling mode.
- e. Overload protection
 - i. If it detects that the system current surpassed the designed 13 A for continuous 3 seconds, compressor, electric heater and outdoor motor stop, indoor motor runs the same procedures as the blowing surplus heat condition. After 3 minutes and current no more than 13 A, the machine will be back to its original state, indoor motor runs as the anti cool air condition. If it detects overloading state for 3 con-

secutive times within 30 minutes, the machine stops, and it must be restarted by remote controller.

- f. Defrosting conditions and procedures
 - i. In heating mode, if compressor has run 44 minutes (in its first 6 minutes it will not detect defrosting temp.) , and it has detected $T_{con} \leq -4^{\circ}\text{C}$ for continuous 1 minutes, it begins to defrost, electric heater will stop for 10 seconds (even if electric heater is not working), then indoor motor stops, reversing valve becomes inactive in another 2 seconds, another 2 seconds later, outdoor motor stops, when $T_{con} \geq 10^{\circ}\text{C}$ or defrosting lasts for 10 minutes, outdoor motor and reversing valve becomes active, indoor motor will run as the anti cool air condition, then it cycles again, recalculates the compressor's running time again. (In this period, if any protection works, and after the machine is back to work, it will re-start defrosting state. it will not detect outdoor tube temp when compressor's in its first 6 minutes running)
- g. Noise eliminated protection
 - i. When you use RUN/STOP button to switch off the machine, reversing valve will become inactive in 2 minutes.

AUTO mode

- 1 In AUTO mode, standard cooling T set = 25°C , standard heating T set = 20°C .
- 2 Working procedures
 - a. If $T_{indoor} \geq T_{set} + 1^{\circ}\text{C}$, select cooling mode, from this time, the set temp. is 25°C . If $T_{indoor} \leq T_{set} - 1^{\circ}\text{C}$, compressor and outdoor motor stop, indoor motor runs at the set speed, if $T_{set} - 1 < T_{indoor} < T_{set} + 1^{\circ}\text{C}$, keep the original state.
 - b. If $T_{indoor} \leq T_{set} + 2^{\circ}\text{C}$, select heating mode, from this time, the set temp. is 20°C , if $T_{indoor} \geq T_{set} + 4^{\circ}\text{C}$, compressor stops first, outdoor motor stops 15 seconds later, reversing valve is always active, indoor motor runs as the blowing surplus heat condition. If $T_{set} + 2^{\circ}\text{C} < T_{indoor} < T_{set} + 4^{\circ}\text{C}$, keeps the original state.
Cooling only AUTO mode: there is no heating function in this mode.
- 3 Protections
 - a. It is same as the one in cooling or heating mode.

4 Other controls

- 1 SWING mode
 - a. When it is active, the louver returns to position O, close the air outlet.
 - b. When machine works, it turns to the max. Air output position D, then returns back to position L to stand by (position L is the horizontal place mentioned before).
 - c. In swing state, the louver swings between position L and position D.
 - d. When the machine is switched off, it is back to position O.
 - e. When the machine is running and the swing is off, the louver stops at position E.

O



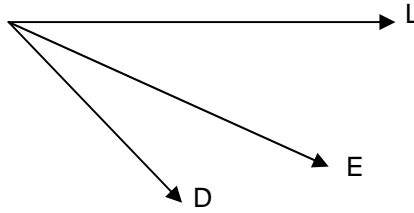

- 2 Beeper
 - a. When PCB becomes active or receives the signal from the remote controller, the beeper will beep.
- 3 Indication lamps
 - a. It flashes when defrosting begin.
- 4 Press the AUTO button a time, the machine runs in AUTO mode, indoor motor runs in low speed, fresh air function is not active, press again the machine stops.
- 5 Fresh air function.
 - a. There are two fresh air modes.
 - Fresh air 2**
 - i. Fresh air motor will work 1 hour, then rest 1 hour, then cycle again.
 - Fresh air 1**
 - ii. Press the button AIR on the remote controller to select fresh air 1 function, the swing motor keeps running till you give a signal to change it.
- 6 Automatic fan speed.
 - a. In cooling mode, if $T_{\text{indoor}} > T_{\text{set}} + 5^{\circ}\text{C}$ high speed
 $T_{\text{indoor}} > \text{or} = T_{\text{set}} + 3^{\circ}\text{C}$ middle speed
 $T_{\text{indoor}} > \text{or} = T_{\text{set}} + 1^{\circ}\text{C}$ low speed
 - b. In dehumidify mode, if $T_{\text{indoor}} > \text{or} = T_{\text{set}} + 5^{\circ}\text{C}$ high speed
 $T_{\text{indoor}} > \text{or} = T_{\text{set}} + 2^{\circ}\text{C}$ low speed

SLEEP mode

- 1 In cooling or dehumidifying mode, 1 hour after you set the sleep timer, T_{set} will add 1°C automatically, another 1 hour, another 1°C will be added.
- 2 In heating mode, 1 hour after you preset the sleep timer, T_{set} will lower 1°C automatically, another 1 hour, another 1°C will be lowered.

