

APPROVALS	DATE	TITLE		
DRAWN J. Cooper	10/15/04	X7000 LIGHT SOURCE REPAIR MANUAL		
ORIGINATOR J. Cooper	10/15/04			
DOC. CONTROL		SIZE	DOCUMENT NO.	SHEET OF
		A	1000-400-755	1 31

REVISIONS			
LTR	ECN NO.	DATE	APPROVED
A	38474	10/15/04	J. Cooper

REVISIONS			
LTR	ECN NO.	DATE	APPROVED

X7000

Light Source

Repair Manual



Warranty

Stryker Endoscopy warrants the X-7000 Light Source against defects in both materials and workmanship to the registered owner at the time of purchase. All components are covered by the warranty for a period of one year from the date of purchase.

This warranty does not apply to any unit which has been the subject of misuse, abuse, neglect, improper installation or operation or that which has been altered, adjusted, or tampered with by any person other than Stryker Endoscopy authorized service personnel.

The customer is responsible for returning the defective equipment to the factory at his or her own expense. Stryker Endoscopy or its representative will service the unit, repair or replace any defective parts thereof, and return the unit.

If, upon examination, it is determined that the fault has been caused by misuse or abnormal conditions of operation, the repairs will be billed to the customer in the same manner as out-of-warranty repairs.

Products repaired by Stryker Endoscopy will be issued a 30 day repair warranty against defects in both materials and workmanship, provided the original warranty period has expired. This warranty applies only to products that have been repaired by Stryker. Instruments submitted due to defects in materials and workmanship during the warranty period will be repaired at no charge to the customer.

The warranty as set forth herein is exclusive and in lieu of all other warranties, remedies, obligations, and liabilities of Stryker Endoscopy Inc., expressed or implied, including the implied warranties of merchantability and fitness for use and of consequential damages. These products are being sold only for the purpose described herein, and such warranty only runs to the original purchaser. In no event

shall Stryker Endoscopy be liable for any breach of warranty in any amount exceeding the purchase price of the product.

No agent, employee or representative of Stryker Endoscopy has the authority to bind the Company to any other warranty, affirmation, or representation concerning this instrument.

This warranty is valid only to the original purchaser of Stryker Endoscopy products directly from Stryker Endoscopy or from a Stryker Endoscopy authorized agent. The warranty cannot be transferred or assigned by the original purchaser.

The X-7000 Light Source warranty is void if any WARNINGS, CAUTIONS, or NOTES are disregarded.

All Stryker products are warranted against defects in materials and workmanship.

© Stryker and Stryker Endoscopy are registered trademarks of Stryker Corporation.

Table of Contents

1.0 INTRODUCTION

1.1 Scope.....	1
1.2 Responsibility.....	1
1.3 Upgrades.....	1
1.4 Equipment Overview.....	1
1.5 Service Options.....	1
1.6 Maintenance Precautions.....	1
1.7 Factory Service Instructions.....	2
1.8 Required Equipment.....	2
1.9 Required Skills.....	2
1.10 Required Replacement Components.....	2

2.0 DIAGNOSTICS AND CORRECTIVE MAINTENANCE

2.1 General Recommendations.....	3
2.2 Power Requirements.....	3
2.3 Ambient Requirements.....	3
2.4 Connections and Wiring.....	3
2.5 Verify Operation.....	3

3.0 REPAIR CHECKLIST AND MATRIX

3.1 Diagnostic Analysis Checklist.....	5
3.2 Repair Matrix	6

4.0 COMPONENT REMOVAL AND REPAIR

4.1 Component Replacement Instructions.....	7
4.1.1 Component Removal Table.....	7
4.1.2 Individual Replacement Instructions.....	8
4.2 Console Cover Removal	8
4.3 Power Source Components.....	9
4.3.1 Control Board Replacement.....	9
4.3.2 Lamp Ballast Replacement.....	10
4.3.3 AC Inlet Board Replacement.....	11
4.3.4 Ballast Fan Replacement.....	12
4.4 Light Source Components.....	12
4.4.1 Bulb Fan Replacement.....	12
4.4.2 Bulb Board Replacement.....	13
4.4.3 Shutter Replacement.....	13
4.4.4 Hot Mirror Replacement.....	13
4.4.5 Motor Mount Replacement.....	14
4.4.6.1 Motor Replacement.....	15
4.4.6.2 Integrating Rod Replacement.....	15

4.5 Front Panel Components.....	16
4.5.1 Jaw Handle Replacement.....	16
4.5.2 Potentiometer Knob Replacement.....	16
4.5.3 Front Panel Replacement.....	17
4.5.4 Jaw Assembly Replacement.....	17
4.5.5 Power Switch Replacement.....	18
4.5.6 Display Board Replacement.....	18
4.6 Fuse Replacement.....	19
4.6.1 Rear Panel Fuses.....	19
5.0 ELECTRONIC PROCEDURES	
5.1 Required Skills.....	20
5.2 Alignment and Calibration.....	20
6.0 FINAL ASSEMBLY AND TESTING	
6.1 Required Skills.....	21
6.2 Assembly.....	21
6.3 Electrical Current Leakage Test.....	21
6.4 Hi-Pot Test.....	22
7.0 APPENDIX	
7.1 Assembly Diagram.....	23
7.2 Parts Listing.....	23
7.3 Reference Documents.....	23
8.0 WARRANTY	
.....	24
9.0 SERVICE	
.....	24
10.0 OTHER SERVICE	
.....	25

1.0 Introduction

1.1 SCOPE

This manual is intended to be used as a reference guide for electronics technicians and the Stryker Repair Team in the analysis and repair procedures for the X-7000 Light Source. It is meant to be used in conjunction with the Stryker X-7000 Universal Light Source Operating and Maintenance Manual (Stryker P/N 1000-400-651) and does not replace existing documentation.

Stryker Endoscopy maintains a complete repair department for the sole purpose of providing efficient and reliable service.

1.2 RESPONSIBILITY

Stryker Endoscopy accepts full responsibility for the effects on safety, reliability, and performance of the equipment only if readjustments, modifications and repairs have been carried out exclusively by a person specifically authorized by Stryker Endoscopy to do so.

In no event shall Stryker Endoscopy be liable for incidental or consequential damages in connection with or arising from the performance or use of its products after unauthorized modification or repair performed by individuals other than Stryker Endoscopy personnel.

1.3 UPGRADES

The Stryker Endoscopy X-7000 Light Source is a high performance device designed for use with Stryker Endoscopy medical video cameras to provide outstanding illumination of the surgical site across all endoscopic applications. With the proper light cable and adapters, it can be connected to any flexible or rigid endoscope. Stryker Endoscopy reserves the right to incorporate improvements without notice. However, updated parts will be fully interchangeable with older versions and will offer at least the same level of quality and performance.

Stryker Endoscopy will inform customers of significant upgrades to the product. Contact your Stryker representa-

tive for up-to-date information on available options and upgrades to equipment as well as updates to this manual.

1.4 EQUIPMENT OVERVIEW

The Stryker Endoscopy X-7000 Light Source consists of the light source, power cord, and Operation and Maintenance Manual. Replacement or spare lamps can be purchased separately.

1.5 SERVICE OPTIONS

The user is advised to return a malfunctioning unit to Stryker Endoscopy for repair or replacement, where specialized equipment and technicians are available to perform repairs while maintaining full product quality and safety.

In the event that the user decides to undertake repair procedures, Stryker Endoscopy recommends that these be carried out only by qualified technicians with proper test equipment listed in this manual, so that the safety of operators and patients may not be compromised.

1.6 MAINTENANCE PRECAUTIONS

WARNING: The incorrect use of any of the required tools and techniques may risk damage to the equipment or injury to the person carrying out the procedure, subsequent operators, or patient. Repairs should be made **ONLY** by those that have been specifically trained in the use of all pertinent equipment and techniques. Stryker Endoscopy cannot continue to guarantee compliance to UL, CSA, TUV, or other labeled safety standards if service is performed by anyone other than Stryker Endoscopy Personnel.



1.7 FACTORY SERVICE INSTRUCTIONS

If service is needed either during or after the warranty period:

Contact Stryker Endoscopy at 1-800-624-4422 or contact your local Stryker Endoscopy sales representative. If needed, a loaner unit may be requested during the time of your unit repair.

Package the X-7000 carefully in the original shipping container, if possible.

Ship the Stryker Endoscopy X-7000 Light Source, prepaid and insured, to:

Stryker Endoscopy Customer Service
Attention: Repair Department
5900 Optical Court
San Jose, CA 95138

1.8 REQUIRED EQUIPMENT

Most of the procedures described in this manual require the following basic tool kit:

- Small flat blade screwdriver
- Medium Philips screwdriver
- 8" adjustable wrench
- Needlenose pliers
- Small wire cutting pliers
- Wire stripper
- Soldering iron and solder
- Multimeter
- Stryker medical video camera
- Stryker Scope
- Fiber optic cable
- Glass fuse puller
- Shorting clip
- Bio Tek Model 170 Analyzer or equivalent current leakage tester
- Nut drivers 11/32" and 5/16"
- Open end wrenches 7/16" and 1/2"
- Set of standard allen wrenches / hex keys
- Hi-Pot Tester

1.9 REQUIRED SKILLS

Each diagnostic and repair procedure described in this manual requires a technician qualified by training or experience in the following areas:

- Basic electronics techniques
- Multimeter operation

1.10 REQUIRED REPLACEMENT COMPONENTS

If a repair procedure necessitates replacements parts, please refer to the Appendix (page 22).

2.0 Diagnostic and Corrective Maintenance

2.1 GENERAL RECOMMENDATIONS

The Stryker Endoscopy Model X-7000 Light Source is a precision instrument which has been engineered and manufactured with great care to ensure the safety of operators and patients. In order to maintain the high level of safety and reliability required of the X-7000, it is important to fully understand and comply with all required procedures set out herein.

If some part of a procedure is omitted or adequate equipment is not used, the safety and performance of the device may be unknowingly compromised. It is strongly recommended that if any element in these procedures is beyond the scope of the technician's training, refer to section 1.7 for information on obtaining fully qualified professional service at Stryker Endoscopy.

WARNING: As is the case with all AC powered devices, dangerous voltages are present. If adequate safety precautions are not taken, results may include damage to the equipment, injury, or death. It is imperative that these procedures be approached only by trained technicians with proper equipment after fully reading and understanding the steps involved.



2.2 POWER REQUIREMENTS

- There is one AC power cord for the X-7000 Light Source. A separate AC power cord is normally required for any other instrument being used.
- Each instrument is clearly marked for power requirements at the AC power cord connection.
- Testing the outlet for proper grounding and polarity is highly recommended prior to connecting the X-7000 Light Source. If available, a ground-fault-interrupt type outlet will provide an additional level of safety.

NOTE: A proper electrical installation procedure will ensure that all associated signal cabling is correctly installed prior to applying AC power to the system.

2.3 AMBIENT REQUIREMENTS

Ensure that:

- The distance between the X-7000 Light Source and the associated devices does not exceed the available cable length.
- Controls will be easily accessible to operator.
- Ventilation is not obstructed around the unit. Avoid locations with excessive heat or temperature fluctuations, such as direct sunlight.

2.4 CONNECTIONS AND WIRING

Please refer to the procedures detailed in the X-7000 Universal Light Source Operating and Maintenance Manual (Stryker P/N #1000-400-651).

2.5 VERIFY OPERATION

After ensuring that both power and signal connections have been correctly made, place the power switch in each unit to the "ON" position. Check that an image is present on the monitor.

3.0 Repair Checklist and Matrix

3.1 INITIAL REPAIR CHECKLIST

The following page is intended for use by qualified Stryker personnel only. Complete a copy of the checklist and file it in the DHR.

3.2 REPAIR MATRIX #1

3.3 REPAIR MATRIX #2

The Repair Matrices are intended for use by qualified Stryker personnel only, in conjunction with section 4.0 (Component Removal and Repair). See page 6 and 7 for Repair Matrices.

DIAGNOSTIC ANALYSIS CHECKLIST

CHECK DATE: _____ NAME: _____

SERIAL #: _____

What is the customer complaint?			
General Assembly Check Points		Yes/No	Details
Is there any visual damage on the unit?			
Are the door switches plastic or metal?			
Are there screws on the door switches?			
What is the Rev of the control board? (Rev. stamped on control board)			
Does the front display board backlight turn on when the device			
Does warm message appear when the unit is powered on?			
Does the unit turn on the front panel LEDs as expected after warm message?			
What is the software version number?			
How many hours are there on the bulb?			
System Checks		Yes/No	Details
Does the unit have D53 and D54 chips? (Rev. F and prior versions only)			
Does the unit turn on the bulb when the interlocks are closed? (door and light cable)			
Does the unit show the brightness properly?			
Does the unit switch between run/standby?			
Does the unit switch between auto/manual?			
When the cable is pulled out, does the bulb turn OFF?			
If not, record the voltage between TP20 and GND.			Cable in: Cable out:
When the door is opened, does the bulb turn OFF?			
If not, record the voltage between TP23 and GND.			Door open: Door closed:
Failure Diagnostics		Yes/No	Details
Is power button flashing when powered on?			
Disconnect the ballast from the control board and connect the jumper cable, Does the bulb turn ON?			
If the bulb does not turn on,			
Measure the boost voltage.			Boost voltage =
Measure the 5-V line voltage on the jumper.			5-V line value =
Measure the 12-V line voltage on the jumper.			12-V line value =
Other Observations:			
Staff Recommendation:			

4.0 Component Removal and Repair

4.1 COMPONENT REPLACEMENT INSTRUCTIONS

Required skills:

Basic electronics techniques.

WARNING: The incorrect use of any of the required tools and techniques may risk damage to the equipment or injury to the person carrying out the procedure, subsequent operators, or patient. Repairs should be made **ONLY** by those that have been specifically trained in the use of all pertinent equipment and techniques.



The following instructions apply to the removal of components from the X-7000. To remove a component for replacement or repair will require the removal of certain other components. Components must be removed in the order listed in the following procedures.

The table in section 4.1.1 shows the order in which components must be removed according to the basic physical assembly of the X-7000. To remove a component for replacement, or repair, begin with section 4.2 and proceed accordingly to the appropriate section.

4.1.1 Component Removal Table

NOTE: All components in previous columns must be removed before removing a component.

1	2	3	4	5
Control Board	Ballast	AC Inlet Board		
	Ballast Fan			
Bulb, Bulb Fan	Bulb Board			
	Shutter			
				Integrating Rod
Slide Button, Jaw Knob	Front Panel	Power Switch		
		Display Board		
		Jaw Assembly		

4.1.2 Individual Replacement Instructions

NOTE: Before removing any component in the X-7000, the Console Cover must be removed (refer to section 4.2).

To remove and repair any of the following components, proceed to section 4.3 (Power Source Components):

- Control Board (4.3.1)
- Lamp Ballast (4.3.2)
- AC Inlet Board (4.3.3)
- Ballast Fan (4.3.4)

To remove and repair any of the following components, proceed to section 4.4 (Light Source Components):

- Bulb (4.4.1)
- Bulb Fan (4.4.2)
- Shutter (4.4.3)
- Hot Mirror (4.4.4)
- Motor Mount (4.4.5)
- Motor (4.4.6.1)
- Integrating Rod (4.4.6.2)

To remove and repair any of the following components, proceed to section 4.5 (Front Panel Components):

- Jaw Handle (4.5.1)
- Potentiometer Knob (4.5.2)
- Front Panel (4.5.3)
- Jaw Assembly (4.5.4)
- Power Switch (4.5.5)
- Display Board (4.5.6)

To remove and repair any of the following components, proceed to section 4.6 (Rear Board Components):

- Fuses (4.6.1)

4.2 CONSOLE COVER REMOVAL

Tools Required:

Basic Tool Kit

- Remove power cord.
- On the back of the unit, remove the two screws attaching the console to the unit.
- Open the lamp door latch on the side of the unit and open the door.
- Slide the cover back, then lift off.

4.3 POWER SOURCE COMPONENTS

4.3.1 Control Board Replacement

Tools Required:

Basic Tool Kit

- Remove power cord and console cover (procedure 4.2).
- Disconnect connectors and attached wires.
- Remove the 5 screws attaching the control board to the ballast.
- Unscrew the nut and washer on the BNC connector.
- Remove the old control board.
- Install a new control board with 4 screws.
- Reattach the connectors to their original locations, including attaching the ground for the ribbon cable with the 5th screw.
- Screw washer and nut onto BNC.
- Perform calibration (procedure 5.2).
- Reinstall the console cover.
- Perform Electrical Current Leakage Test (procedure 6.3).

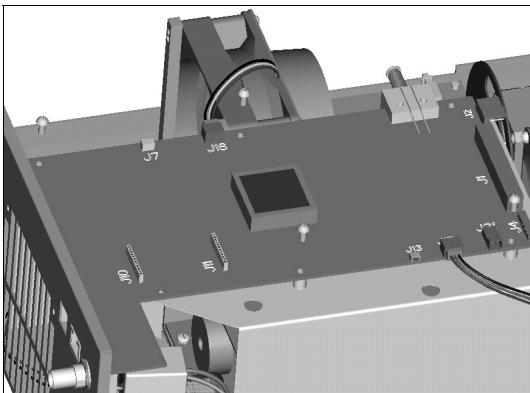
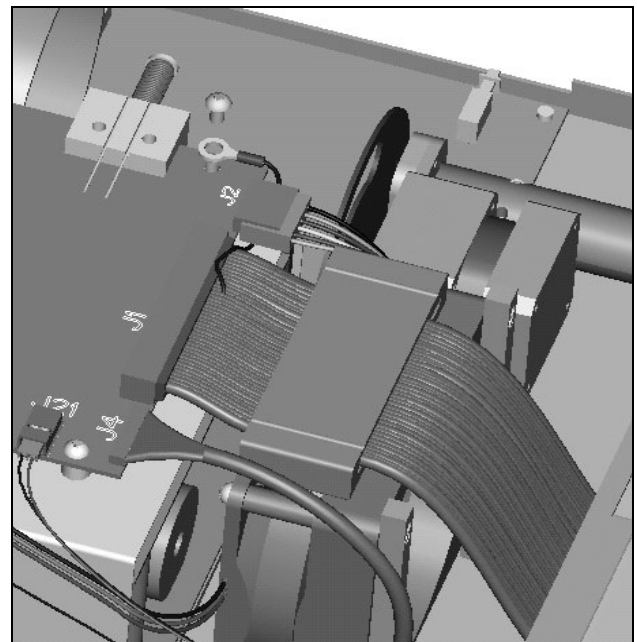
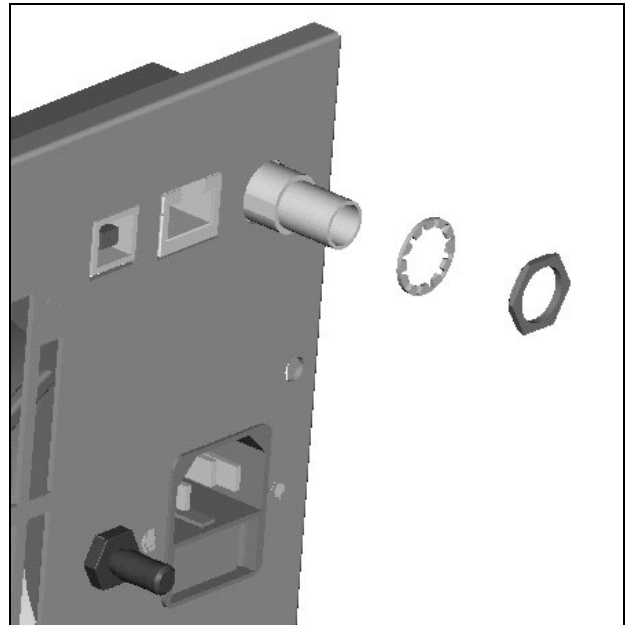

4.3.2 Lamp Ballast Replacement

Tools Required:

Basic Tool Kit

- Remove power cord and console cover (procedure 4.2).
- Remove the control board (procedure 4.3.1).
- Label and disconnect the three power input cables located at the rear of the ballast.
- Remove the bulb holder assembly.
- Using the X-Long Magnetic Phillips screwdriver, remove the 4 screws attaching the lamp ballast to the chassis.
- Replace the lamp ballast assembly.
- Install new ballast assembly using an X-Long Magnetic Phillips screwdriver.
- Reconnect all cables previously disconnected.
- Reattach the control board to the chassis.
- Reinstall the console cover.
- Perform Electrical Current Leakage Test (procedure 6.3).
- Perform Hi-Pot test (procedure 6.4).

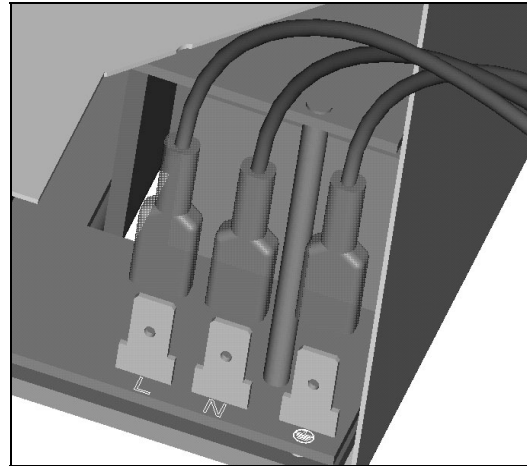

4.3.3 AC Inlet Board Replacement

Tools Required:

Basic Tool Kit

- Remove power cord and console cover (procedure 4.2).
- Remove the control board (procedure 4.3.1).
- Remove the lamp ballast (procedure 4.3.2).
- Remove the 2 bolts from the 2 nuts.
- Remove the 1-2 screws from the AC inlet board (number of screws varies by revision).
- Remove the wiring harness from the J2 connector.

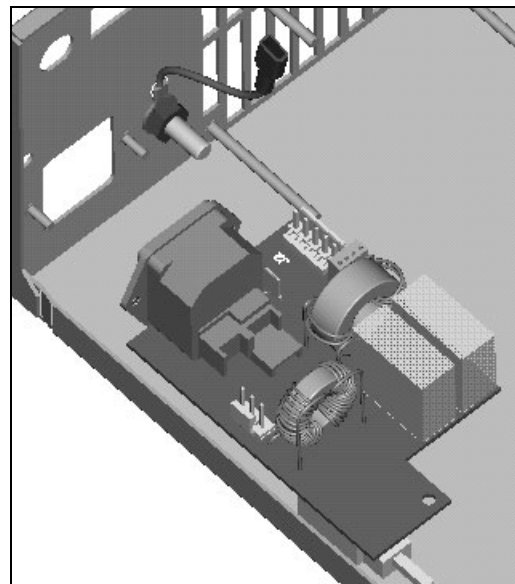
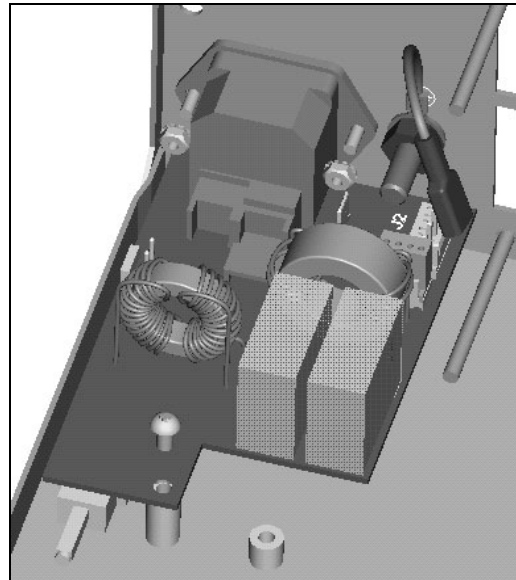

4.3.4 Ballast Fan Replacement

Tools Required:

Basic Tool Kit

NOTE: BOTH fans must be replaced if one fan malfunctions.

- Remove power cord and console cover (procedure 4.2).
- Remove the black ribbon cable.
- Remove the fan wire harness assembly.
- Note the fan orientation.
- Remove the 2 nuts attaching the fan to the Chassis and remove the sub-assembly.
- Remove the 4 screws from the fan mounts.
- Remove the malfunctioning fan(s) and replace. Ensure the correct orientation.
- Reinstall the 2 fan mounts with the 4 screws.
- Reinstall the 2 nuts.
- Reinstall the black ribbon cable, fan wire harness assembly, and console cover.
- Perform Electrical Current Leakage Test (procedure 6.3).

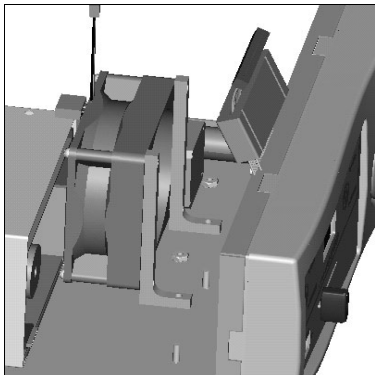

4.4 LIGHT SOURCE COMPONENTS

4.4.1 Bulb Fan Replacement

Tools Required:

Basic Tool Kit

NOTE: BOTH fans must be replaced if one fan malfunctions.

- Remove power cord and console cover (procedure 4.2).
- Remove the bulb module.
- Detach the wire harness from the control board.
- Remove the 2 nuts attaching the bulb fan housing assembly to the chassis.
- Note the fan orientation.
- Remove the 4 nuts attaching the bulb fan to the fan mounts/fan ducts.
- Reinstall the new fan onto the mounts/duct with 4 bolts, ensuring the correct orientation.
- Reinstall the fan assembly onto the chassis with 2 nuts.
- Reconnect the wire harness.
- Replace the bulb module and cover.

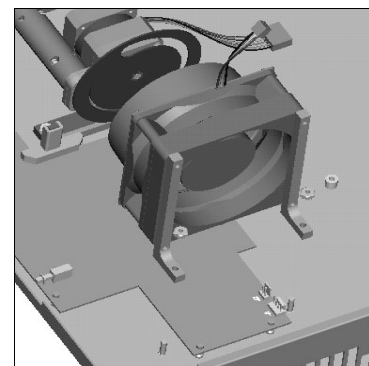

4.4.2 Bulb Board Replacement

- Remove power cord and console cover (procedure 4.2).
- Remove the bulb.
- Remove the bulb fan (procedure 4.4.1).
- Remove the 2 wire harnesses.
- Remove the bulb board and replace.
- Reinstall the 2 wire harnesses, bulb fan, bulb, and cover.

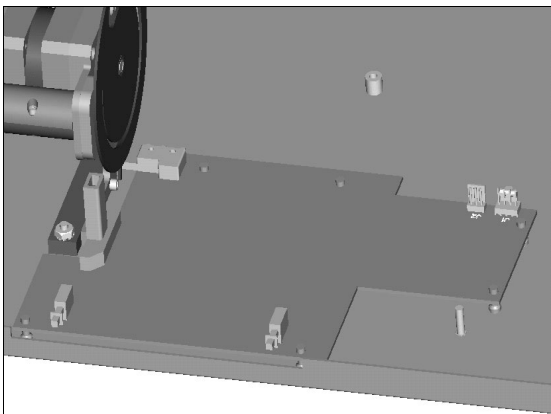

4.4.3 Shutter Replacement

- Remove the power cord and console cover (procedure 4.2).
- Remove the bulb (procedure 4.4.1).
- Remove the Allen screw from the shutter shaft.
- Remove the shutter and replace.
- Reinsert the Allen screw.
- Replace the bulb and cover.

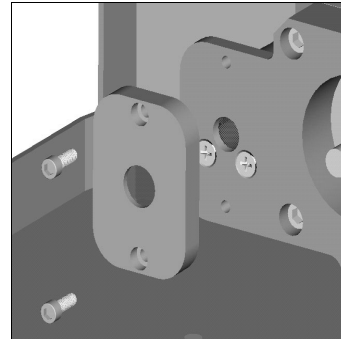

4.4.4 Hot Mirror Replacement

- Remove power cord and console cover (procedure 4.2).
- Remove the bulb (procedure 4.4.1).
- Remove the shutter (procedure 4.4.3).
- Remove the 2 Allen screws.
- Remove the hot mirror mount and replace.
- Reinsert the 2 Allen screws.
- Replace the shutter, bulb, and cover.

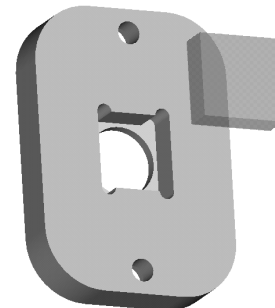

4.4.5 Motor Mount Replacement

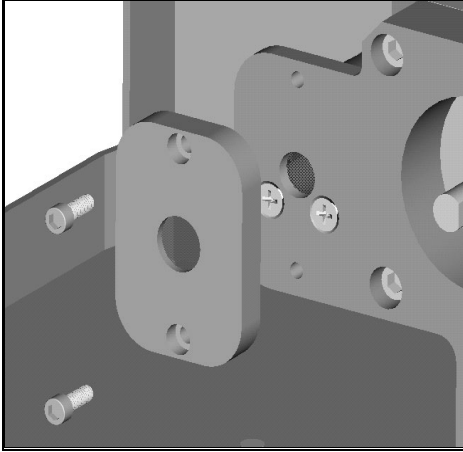

- Remove power cord and console cover (procedure 4.2).
- Remove the bulb (procedure 4.4.1).
- Remove the hot mirror (procedure 4.4.4).
- Remove the 2 Phillips screws from beneath the hot mirror.
- Remove the 2 nuts.
- Remove the motor wire harness from the control board.
- Remove the motor mount assembly with the motor attached, and replace.
- Replace the wire harness.
- Reinsert the 2 nuts and 2 Phillips screws beneath the hot mirror.
- Replace the hot mirror, bulb, and cover.

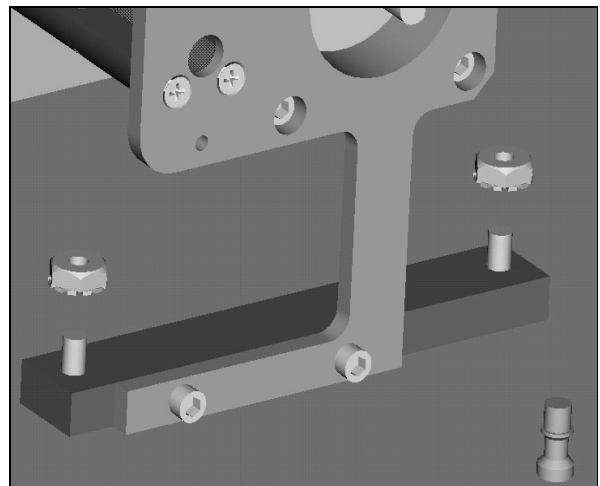
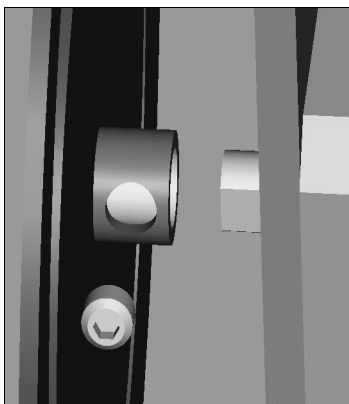
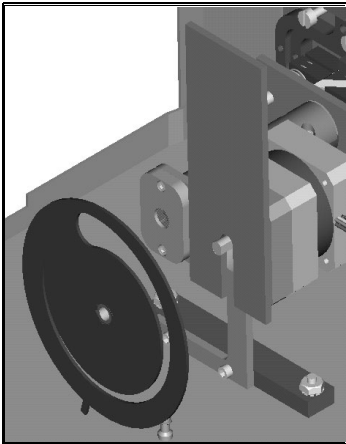

4.4.6.1 Motor Replacement

- Remove power cord and console cover (procedure 4.2).
- Remove the motor mount (procedure 4.4.5).
- Remove the 4 Allen screws.
- Remove the motor and replace.
- Reinsert the 4 Allen screws.
- Replace the motor mount and cover.

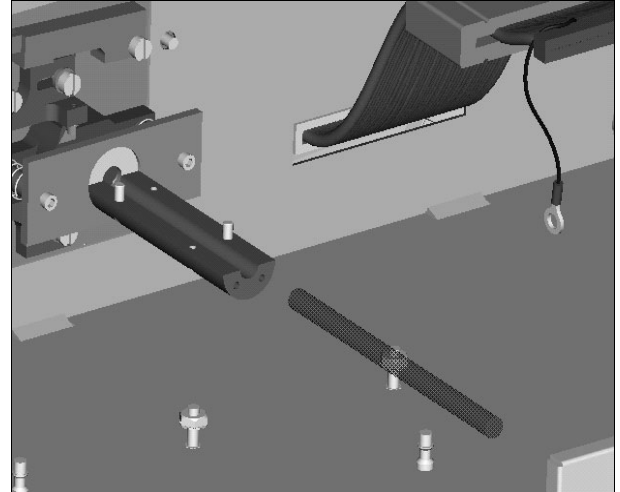

4.4.6.2 Integrating Rod Replacement

- Remove power cord and console cover (procedure 4.2).
- Remove the motor mount (procedure 4.4.5).
- Remove the 2 screws and the cover.
- Slide the integrating rod out.
- Swab the rod holder with alcohol.
- Insert new integrating rod.
- Reinsert the 2 screws.
- Replace the cover and motor mount.

4.5 FRONT PANEL COMPONENTS

4.5.1 Jaw Handle Replacement

- Remove power cord.
- Remove the set screw from the bottom of the jaw handle.
- Remove the jaw handle from the actuator shaft.
- Ensure that the jaw handle key (P/N 105-186-472) stays in place on the actuator shaft.
- Replace the jaw handle onto the actuator shaft.
- Secure the jaw handle in place using the set screw.
- Reinsert the set screw and reinstall the cover.

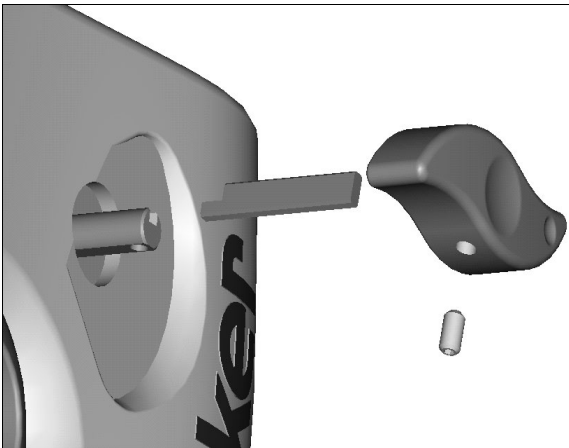

4.5.2 Potentiometer Knob Replacement

- Remove power cord.
- If potentiometer knob is damaged or detaches from the front panel, but the protruding metal tab is still connected, perform the following repair steps:
 - Remove the set screw from the bottom of the potentiometer knob.
 - Remove the knob from the slide pot of the front panel.
 - Loosely screw the set screw into the bottom of the potentiometer knob.
 - With the screw hole facing down, insert the potentiometer knob onto the slide pot.
 - Secure the knob in place by screwing in the set screw.
- If the potentiometer knob is damaged or detaches from the front panel, and the protruding metal tab is also damaged or disconnected, replace the display board and potentiometer knob.

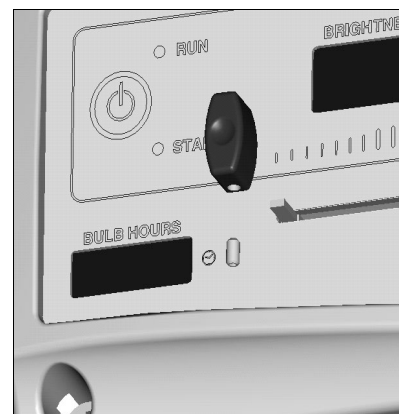

4.5.3 Front Panel Replacement

- Remove power cord and console cover (procedure 4.2).
- Remove the jaw knob and potentiometer knob (procedures 4.5.1 and 4.5.2).

CAUTION: DO NOT DAMAGE THE JAW INTERLOCK CABLE WHEN REMOVING THE FRONT PANEL.



- Disconnect the ribbon cable from the inside of the front panel.
- Disengage the six tabs which hold the front panel onto the chassis.
- Remove the jaw interlock cable from the display board.
- Remove the display board (procedure 4.5.6).
- Remove the power switch (procedure 4.5.4).
- Remove the ESST ring.
- Remove the front panel and replace with new panel.

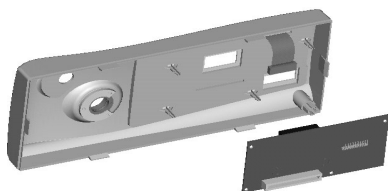
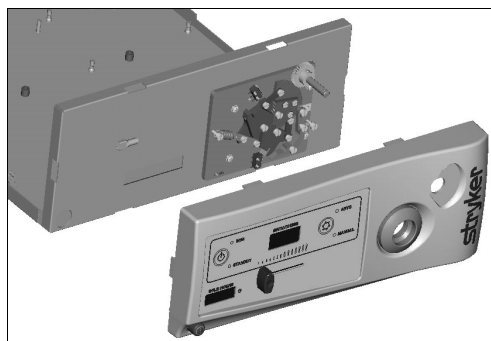

- Replace all removed components.

4.5.4 Jaw Assembly Replacement

- Remove power cord and console cover (procedure 4.2).
- Remove the front panel (procedure 4.5.3).
- Remove the motor mount (procedure 4.4.5).
- Remove the ESST wire harness from the display board.
- Remove the 4 Phillips screws.
- Remove the jaw assembly and replace.
- Reinsert the 4 Phillips screws.
- Replace the ESST wire harness, motor mount, front panel, and cover.

4.5.5 Power Switch Replacement

- Remove power cord and console cover (procedure 4.2).
- Remove the jaw knob and potentiometer knob (procedures 4.5.1 and 4.5.2).
- Remove the front panel (procedure 4.5.3).
- Cut the zip tie over the cables.
- Disconnect wire harness from display board.
- Push in the two snap clips and push out the switch from inside the console.
- Remove the LED and verify its operation.
- Replace the LED if necessary, inserting it to full depth with the appropriate Allen wrench.
- Insert a new power switch.
- Reconnect the wire harness.
- Replace the zip tie, front panel, and console cover.
- Perform Electrical Current Leakage Test (procedure 6.3).

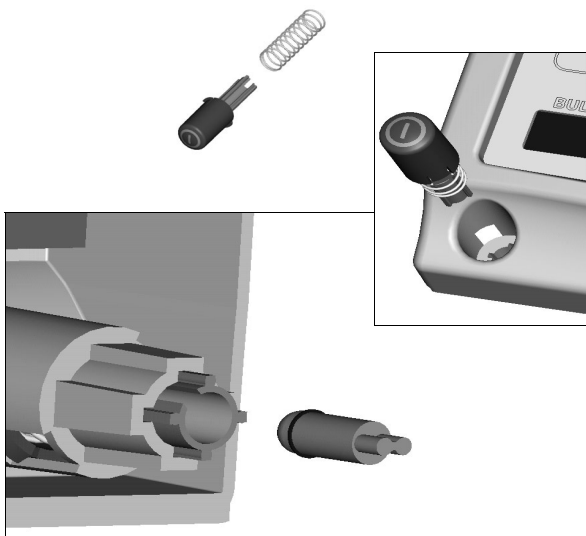

4.5.6 Display Board Replacement

- Remove power cord and console cover (procedure 4.2).
- Remove the front panel (procedure 4.5.3).
- Detach the flex cable from the display board (J1).
- Unclip the 6 front panel clips from the chassis.
- Remove the ESST ring cable from the display board.
- Remove the ribbon cable from the display board.
- Remove the power switch wire harness from the display board.
- Remove the display board from the front panel clips.
- Replace the display board.
- Push the board onto the front panel clips.
- Reattach the power switch wire harness.
- Reattach the ESST ring wire harness.
- Reattach the front panel ribbon cable.
- Reinsert the front panel onto the chassis.
- Reattach the jaw handle and potentiometer knob (procedures 4.5.1 and 4.5.2).
- Reinstall the console cover.
- Perform Electrical Current Leakage Test (procedure 6.3).

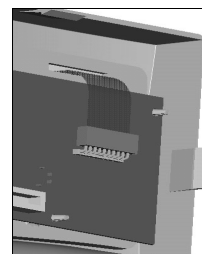

4.6 FUSE REPLACEMENT

4.6.1 Rear Panel Fuse Replacement

Tools Required:

Basic Tool Kit

- Remove power cord.
- Locate the fuse holder below the power cord inlet (see Figure 1).
- Release the fuse holder clamps with a flat head screw driver and remove the fuse holder with 2 attached fuses.
- Wipe the metallic ends of the new fuse(s) with a clean tissue to remove any residue from fingers..
- Remove the old fuse(s) and install a new 5a fuse in the fuse holder.
- Replace the fuse holder with 2 attached fuses.
- Reattach the fuse holder clamps.

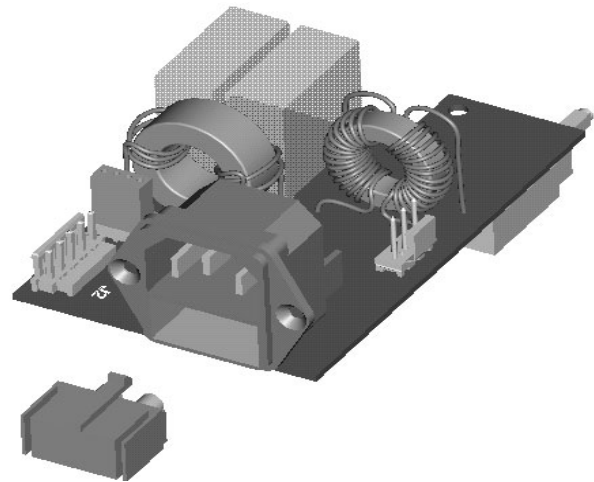
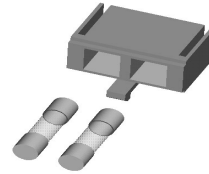

5.0 Electrical Procedures

5.1 REQUIRED SKILLS

- Basic electronics techniques.
- Experience in the operation of an oscilloscope.

WARNING: The incorrect use of any of the required tools and techniques may risk damage to the equipment or injury to the person carrying out the procedure, subsequent operators, or patient. Repairs should be made **ONLY** by those that have been specifically trained in the use of all pertinent and techniques.



5.2 ALIGNMENT AND CALIBRATION

1. Align and calibrate the unit per the instructions in MAP 0337.
2. If the lamp ballast or the control board were replaced, then perform a burn-in and hot strike, per the instructions in MAP 0337.

6.0 Final Assembly and Testing

6.1 REQUIRED SKILLS

- Basic electronics techniques
- Experience in the operation of a Current Leakage Tester.

6.2 ASSEMBLY

- Reinstall all pertinent components.
- Verify that all connectors are firmly attached to their proper locations.
- Ensure that there are no unattached or unsoldered leads.
- Check all physical mounting screws and nuts for tightness.
- Install console cover.
- Apply power and check for proper operation.
- If unit is still malfunctioning after following this manual's instructions, follow procedure 1.7 to obtain factory service at Stryker Endoscopy.
- If the unit appears to be operating correctly, proceed to procedure 6.3.

6.3 ELECTRICAL CURRENT LEAKAGE TEST

Required Equipment:

Bio-Tek Current Leakage Tester

- ALWAYS perform this test after working on the unit and prior to returning it to operation.
- Maximum leakage specification is 500 μ A for "open ground" or single-fault condition.

- Disconnect the X-7000 power cord from the power source.
- Disconnect the video cables from the console.
- Connect the X-7000 power cord to the power receptacle on the safety analyzer front panel.
- Clip the safety analyzer test load to the X-7000 console ground post.
- Set the main power switch on the X-7000 to "ON" and plug in the light cable.
- Set the main power switch on the safety analyzer to the "CHASSIS LEAKAGE μ A" position.
- Read the leakage current in the following positions:

NORMAL POLARITY - NORMAL GROUND
NORMAL POLARITY - OPEN GROUND
REVERSE POLARITY - OPEN GROUND
REVERSE POLARITY - NORMAL GROUND
- If any leakage reading is over 500 μ A, send the unit to Stryker Endoscopy for repair (refer to procedure 1.6 to obtain factory service at Stryker Endoscopy).
- Set the X-7000 power and the safety analyzer power to "OFF"
- Disconnect the safety analyzer from the X-7000.
- This completes the repair procedure

6.4 HI-POT TEST

- Energize the Hi-Pot tester and adjust the voltage by turning the adjusting knob until the meter reads 1.8KV.
- Ensure the Hi-Pot tester is operating properly by touching the positive and negative test leads and listening for the sound emitted.
- If no sound is emitted, turn the equipment in for repair.
- If sound is emitted, reset the unit before proceeding.
- Connect an alligator clip to the neutral and positive terminals of the power plug.
- Turn on the standby and power switches.

WARNING: HIGH VOLTAGE!



- Touch the positive test lead (red probe) to the alligator clip and the negative lead (black probe) to the ground post.
- Hold the leads there for one second. If sound is emitted from the Hi-Pot tester, reject the unit.

7.0 Appendix

7.1 ASSEMBLY DIAGRAM

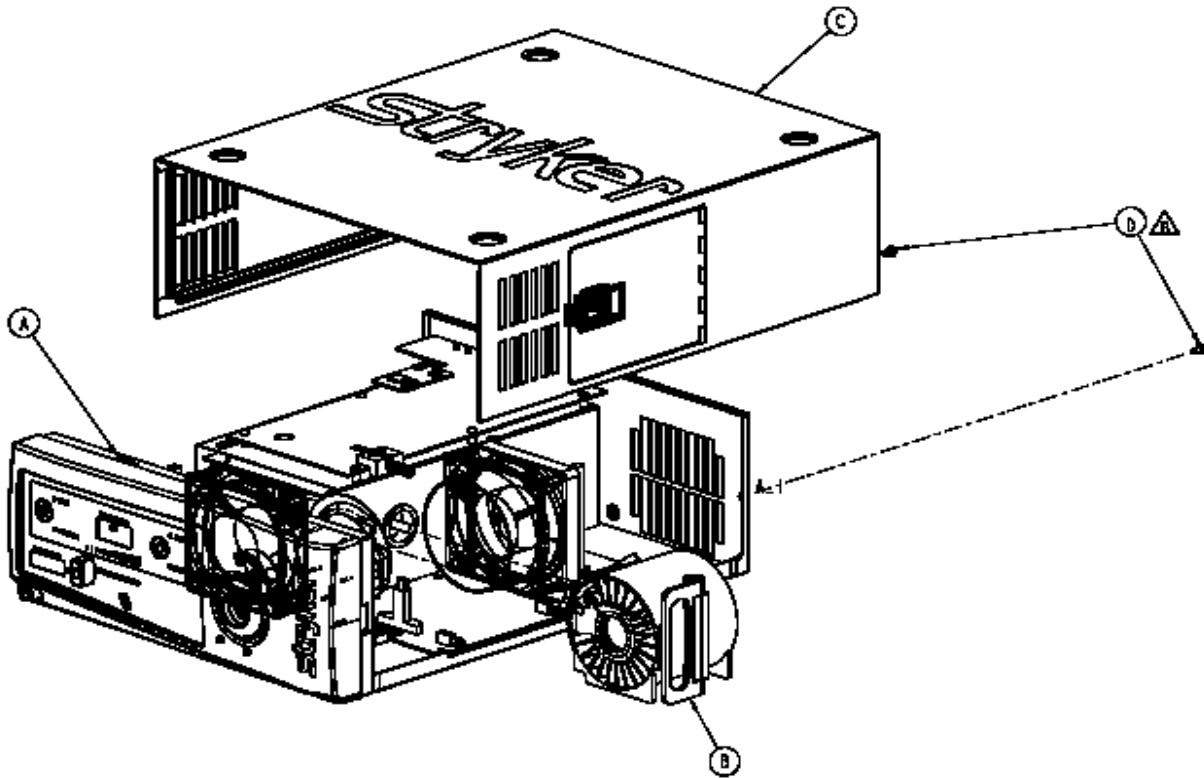

7.2 PARTS LISTING

A	105-199-584	ASSY, X-7000 BOTTOM TRAY
B	105-199-581	ASSY, X-7000 ELLIPTICAL BULB MODULE
C	105-199-678	ASSY, COVER, X-7000
D	105-193-198	SCREW, 6-32 X 0.25 PH EXT. SEMS

7.3 REFERENCE DOCUMENTS

- MAP 0337

NOTE: NONE OF THE IN-HOUSE MAPs (Manufacturing Assembly Procedures), QIPs (Quality Inspection Procedures), SPECIALTY TOOLS, JIGS, OR FIXTURES LISTED IN THIS MANUAL ARE AVAILABLE FOR PURCHASE.

8.0 Warranty

This Stryker Endoscopy product is warranted to the original purchaser to be free from defects in material and workmanship for the following times:

- One year following the date of delivery and an additional 30 days following repair

This warranty extends to all purchases and is limited to the repair or replacement of the product without charge when returned in the original shipping case to:

Stryker Endoscopy
5900 Optical Court
San Jose, CA 95138

Stryker Endoscopy cannot accept responsibility for returns or replacements which have not been authorized. This warranty does not cover damages caused by misuse or by failure to follow the procedures outlined in this manual or demonstrated by Stryker Endoscopy representatives.

There are no other expressed warranties.

9.0 Service

The user is advised to return a malfunctioning unit to Stryker Endoscopy for repair or replacement, where specialized equipment and technicians are available to perform repairs while maintaining full product quality and safety.

In the event that the user decides to undertake repair procedures, Stryker Endoscopy recommends that these be carried out only by qualified technicians with proper test equipment listed in this manual, so that the safety of operators and patients may not be compromised.

If service is needed either during or after the warranty period:

1. Contact Stryker Endoscopy at 1-800-624-4422, or call your local Stryker Endoscopy sales representative.
2. Clean and sterilize all parts that will be returned for service. Follow the instructions provided in the user manual.
3. Package all the components carefully in the original shipping container if possible.
4. Ship the product pre-paid and insured to:

Stryker Endoscopy Customer Service
Attention: Repair Department
5900 Optical Court
San Jose, CA 95138

The product described in this manual is continually being reviewed, and improvements may be made without notice. Stryker and Stryker Endoscopy are registered trademarks of Stryker Corporation.

10.0 Other Service

For service in the U.S.A., call your Stryker Endoscopy Representative. Outside of the U.S.A., please contact your Stryker Endoscopy distributor at one of the following locations:

Stryker Corporation
2725 Fairfield Road
Kalamazoo, MI 49002
USA
Phone:1-269-385-2600
Telex:224464 STRYKER KMZ
Fax:1-269-385-1996

Stryker Canada
45 Innovation Drive
Hamilton, Ontario, Canada
L9H 7L8
Phone: (905) 690-5700
(800) 668-8323 (toll free)
Fax: +1(905) 690-5698

Stryker Deutschland GmbH
Gewerbeallee 18, D-45478
Mulheim an der Ruhr
GERMANY
Phone:49-208-999-060
Fax:49-208-999-0666

Stryker Latin America
15100 N.W. 67th Ave. Suite 210
Miami, Florida 33014
USA
Phone:1-305-821-1888
Fax:1-305-826-0067

Stryker B.V.
Marinus van Meelweg 17
P.O. Box 8747
5657 En Eindhoven
THE NETHERLANDS
Phone:31-40-2922522
Fax:31-40-2922555

Stryker Osteonics, SA
5, Chemin des Aulx 5
1228 Plan-les-Ouates
Case Postale 725
1212 Grand-Lancy 1
Geneve, SWITZERLAND
Phone:41-22-884-0111
Fax:41-22-884-0199

Stryker European Rep - RA/QA Manager
ZAC Satolas Green Pusignan
Av. De Satolas Green
69881 MEYZIEU Cedex, France
Phone:33-1-48175000
Fax:33-1-48632175

Stryker India Private Limited
First Floor
C-5, SDA Commercial Complex
New Delhi 110 017
INDIA
Phone:91-11-686-6740
Fax:91-11-696-6020

Stryker Australia
Unit 58, 2a Herbert St.
St. Leonards NSW 2065
AUSTRALIA
Phone: 02 9467 1000
Fax: 02 9467 1010

Stryker Singapore PTE/LTD
70 Bendemeer Road
#03-32 Hiap Huat House
SINGAPORE 339940
Phone:65-293-0119
Fax:65-293-7028

Stryker Pacific Ltd.
Suite 2501, Citibank Tower
Citibank Plaza
3 Garden Road, Central
HONG KONG
Phone:61-2-9415-5100
Fax:61-29-4294127

Stryker Mexico, S.A. de C.V.
Calle Sacramento 410
Col. Insurgentes San Borja
C.P. 03100
Mexico, D.F.
MEXICO
Phone:525-488-0890
Fax:525-488-0891

Stryker Finland
PL 80 (Makelankatuz)
FIN 00501 Helsinki
FINLAND
Phone:358 (0) 9 7744 680
Fax:358 (0) 9 7744 6820

Stryker Korea
11F Dong Sung Bldg.
154-24 Samsung-dong
Kangnam-ku
Seoul, KOREA 135-090
Phone:82-2-34517572
Fax:82-2-552-4156

Stryker China Limited
Room 903-905, Office Tower 2
Beijing Sun Dong An Plaza
138 Wang Fu Jing Da Jie
Beijing 100006, P.R. China
Phone:86-10-65136183
Fax:86-10-83913571

Stryker Japan
Dai Tokyo Kasai Shinjuku Bldg.
3-25-3, Yoyogi
Shibuya-ku, Tokyo 151-0053
Phone:813-535-29106
Fax:813-535-21789

Stryker Europe Headquarters
Cite-Centre, Grand Rue 92
CH-1820 Montreux
SWITZERLAND
Phone:41-21-966-1201
Fax:41-21-966-1200

Stryker Taiwan
5F-1,23 Pa Te Road
Section 1, Taipei, TAIWAN, R.O.C.
Phone:886-2-2322-2895
Fax:886-2-2357-8543

Stryker U.K. Ltd.
Hambridge Road
Newbury
Berkshire RG14 5 EG
United Kingdom
Phone:44-1635-262400
Fax:44-1635-262464

Stryker Middle East / Africa
Via Della Posta
6934 Bioggio
Switzerland
Phone:(4021) 212-1122
Fax:(4021) 212-1133

NV Stryker SA (Belgium)
Ikaros Business Park Fase III
Ikaroslaan 12
1930 Zaventem
Brussels, BELGIUM
Phone:32-2-717-92-10
Fax:32-2-717-92-49

Stryker Chile
Avenida Nueva Tajamar 481
Oficina 805 Piso 8 Torre Norte Santiago,
CHILE
Phone:562-244-3600
Fax:562-244-3696

Stryker Spain
Manuel Tovar 35
28034 Madrid
SPAIN
Phone:34-91-7283500
Fax:34-91-3580748

Stryker AB Scandinavia
Krossverksgatan 3
S-216 10 Malmö
SWEDEN
Phone:46 40-69-18-100
Fax:46 40-69-18-190

Stryker AB Denmark
Sankt Annae Plads 9
1021 Copenhagen, Denmark
Phone:45 33 9360 99
Fax:45 33 9320 69

MANUFACTURER
Stryker Endoscopy Inc.
5900 Optical Court
San Jose, CA 95138
USA
Phone:408-754-2000
Fax:408-754-2505

stryker[®]

5900 Optical Court
San Jose, CA 95138
408-754-2000
1-800-624-4422

Endoscopy

1000-400-755 Rev. A