

# HONDA

## INSTALLATION INSTRUCTIONS

Accessory  
**HEATED GRIPS**  
 P/N 08T70-MJG-670

Application  
**GL1800B**

Publication No.  
**MII 14360**  
 Issue Date  
**March 2013**

### PARTS LIST

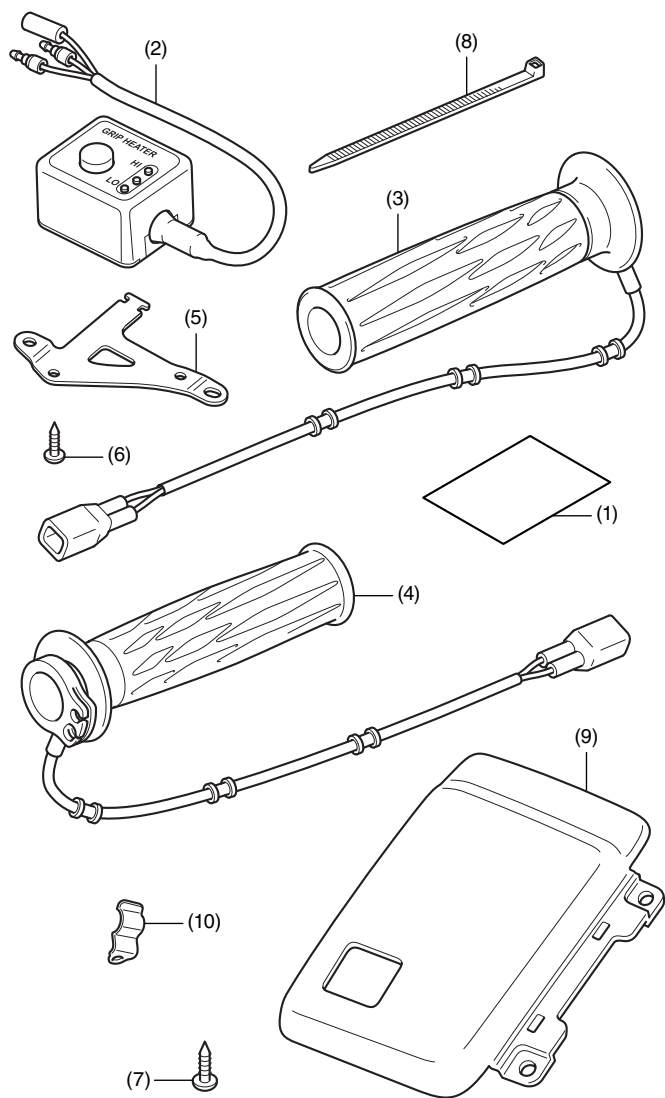

No.	Description	Qty
(1)	Installation Instruction URL	1
(2)	Heater switch	1
(3)	Left heated grip	1
(4)	Right heated grip	1
(5)	Heater switch stay	1
(6)	3 mm screw	2
(7)	4 mm screw	2
(8)	Wire tie	1
(9)	Right front shelter cover	1
(10)	Clamp	2

### TOOLS AND SUPPLIES REQUIRED

- Phillips ® screwdriver
- Flat-tip screwdriver
- Side cutters
- Marker
- Ruler
- Honda Bond A (Pro Honda Handgrip Cement)
- Thread lock
- Grease
- Isopropyl alcohol
- Shop towel
- Torque wrench

### TORQUE CHART

Tighten all screws, bolts, and nuts to their specified torque values. Refer to the Service Manual for the torque values of the removed parts.

Item	N·m	kgf·m	lbf·ft
4 mm screw	1	0.1	0.7

# INSTALLATION

## ▲ CAUTION

- To prevent burns, allow the engine, exhaust system, radiator, etc. to cool before installing the accessory.

### NOTE:

- Disconnect the throttle cable from the right grip as instructed in the motorcycle's Service Manual.
- For secure adhesion of the heated grips use the recommended adhesive agent (Honda Bond A, Pro Honda Handgrip Cement) or equivalent.
- Be sure to open and close the throttle to check for smooth operation after installation of the right heated grip.
- Disconnect the negative (-) cable from the battery before installing this accessory.
- After turning the ignition switch OFF, wait more than 10 seconds and then remove the negative (-) cable from the battery.
- The memories of the tripmeter and clock will be erased when you disconnect the battery. Reset the clock after reconnecting the battery.
- Reinstall the removed parts on the motorcycle and make sure that the wires and harnesses are not pinched.
- Trim the excess ends off the wire ties after attaching them to the wire harnesses. Do not allow the cut part of the wire tie to interfere with another harness or brake hose.
- After heated grip installation, check the lights (e.g. right / left turn signal lights and brake lights) for proper operation.

1. Open the left saddlebag lid as shown.

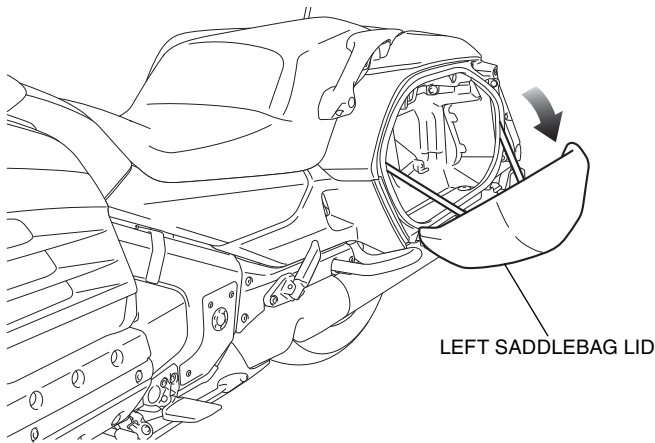

2. Remove the left side cover, and disconnect the negative (-) cable from the battery.

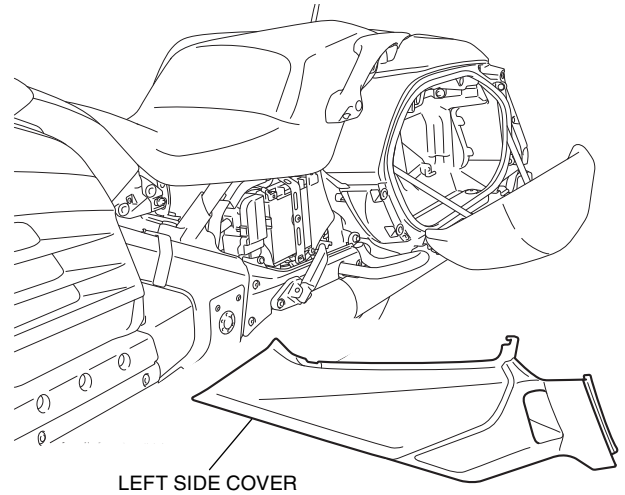

3. Also remove the right side cover.
4. Remove the motorcycle's parts as shown.

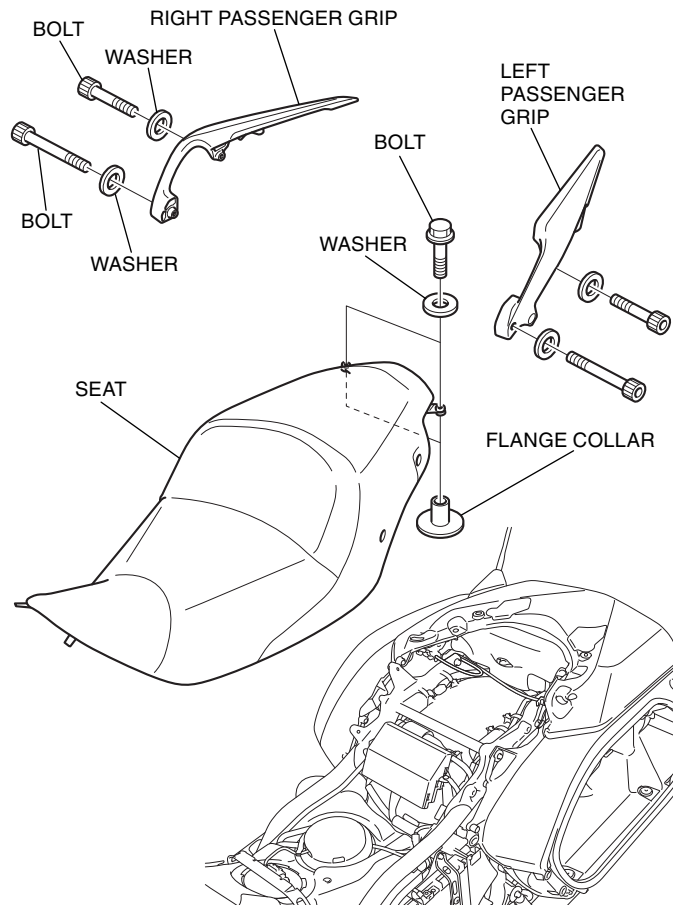

5. Remove the left cowl trim mould as shown.

- Repeat on the right side.

LEFT COWL  
TRIM MOULD

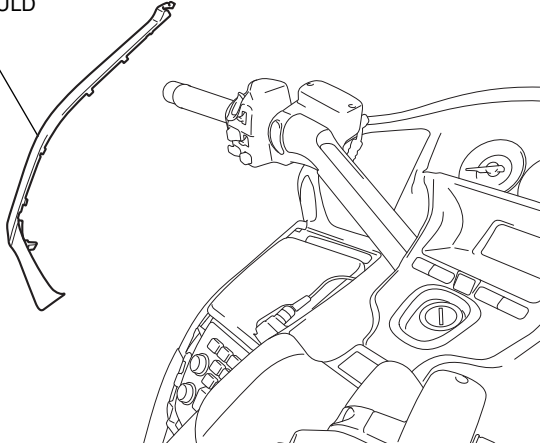

6. Remove the left front pocket as shown.

CLIP

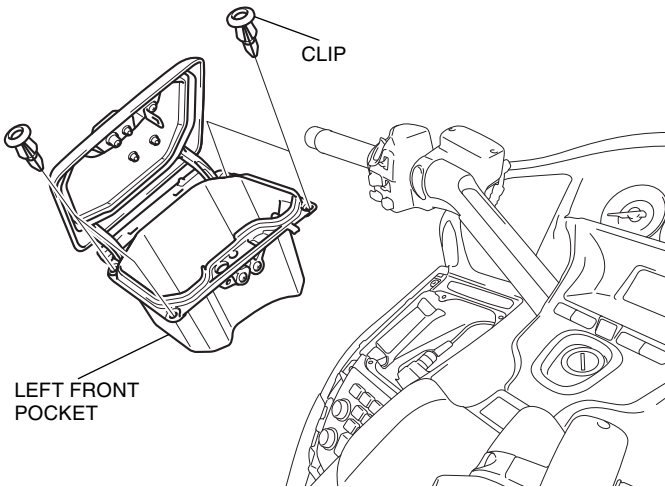

7. Remove the motorcycle's parts as shown.

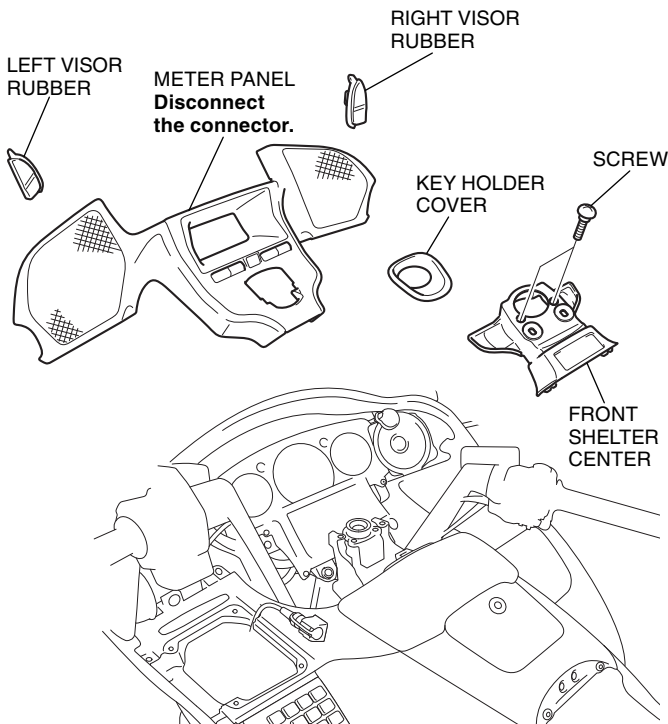

8. Remove the front shelter cover as shown.

FRONT SHELTER  
COVER

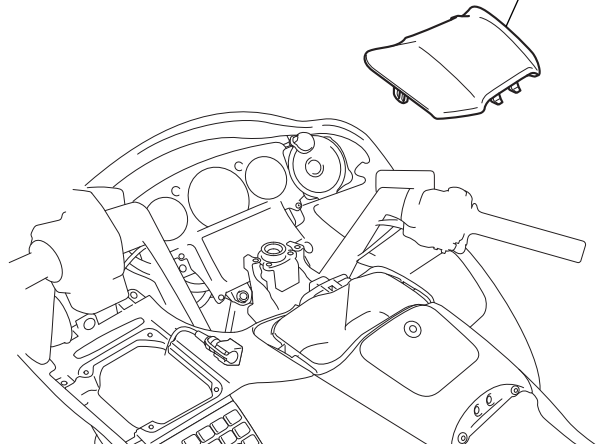

9. Remove the indicated clips.

SHELTER LID  
Open.

CLIP

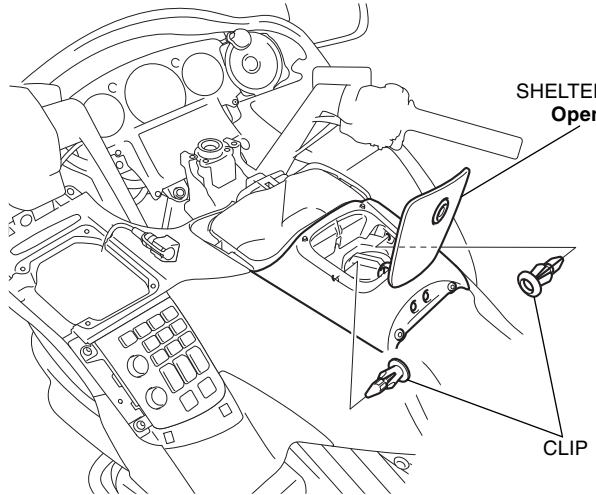

10. Remove the shelter lid as shown.

SHELTER LID

CLIP

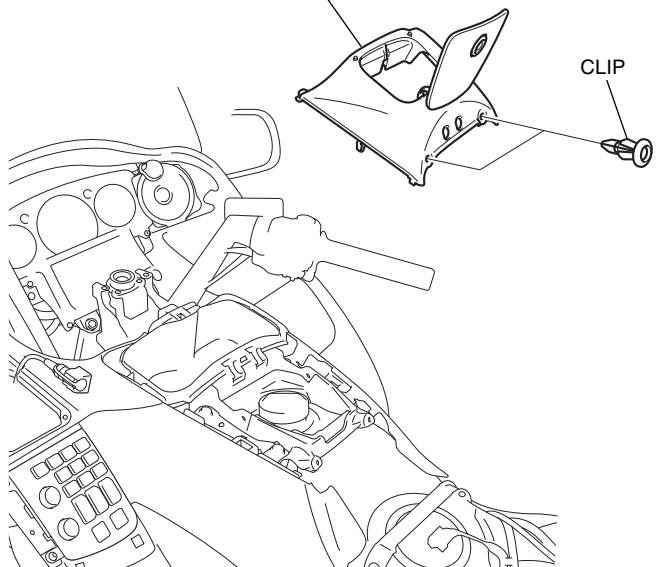

11. Remove the motorcycle's parts as shown.

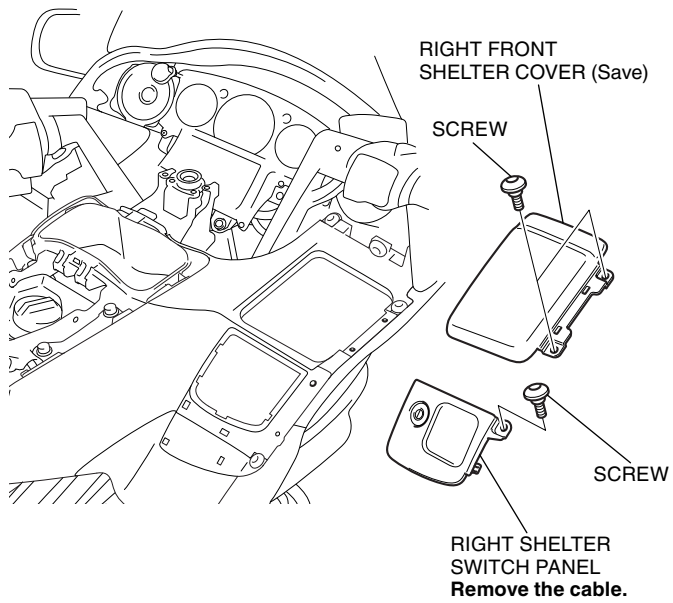

12. Remove the right top shelter as shown.

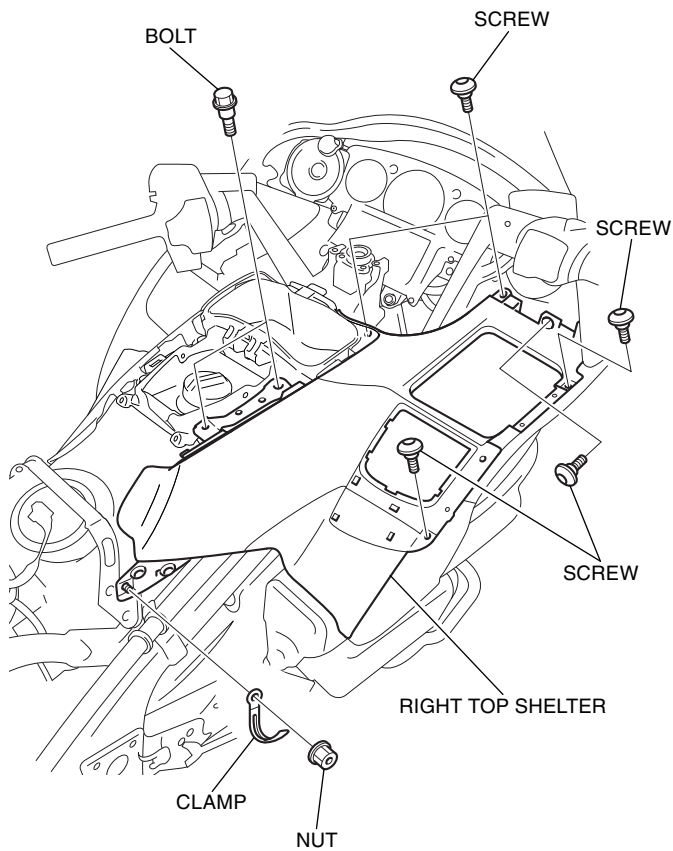

13. Remove the motorcycle's parts as shown.

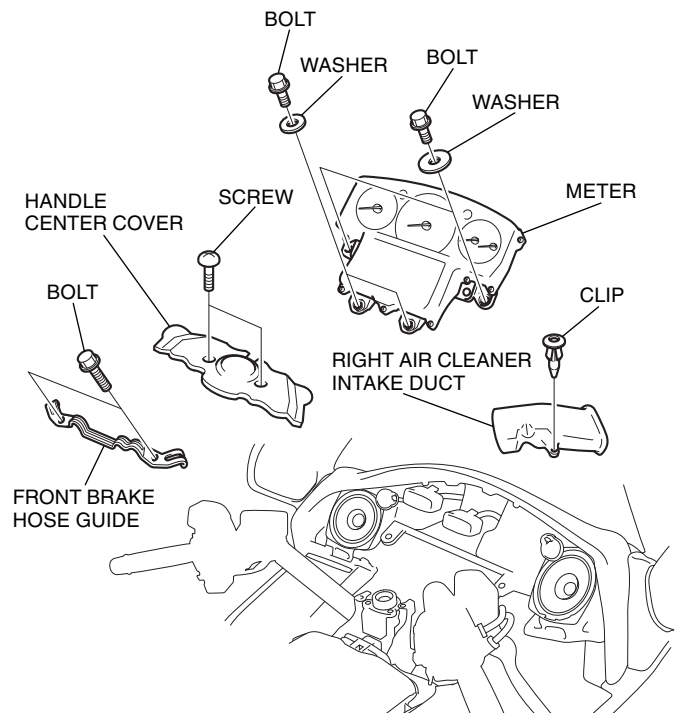

14. Remove the right inner cover as shown.



15. Remove the left handle cover as shown.

- Repeat on the right side.

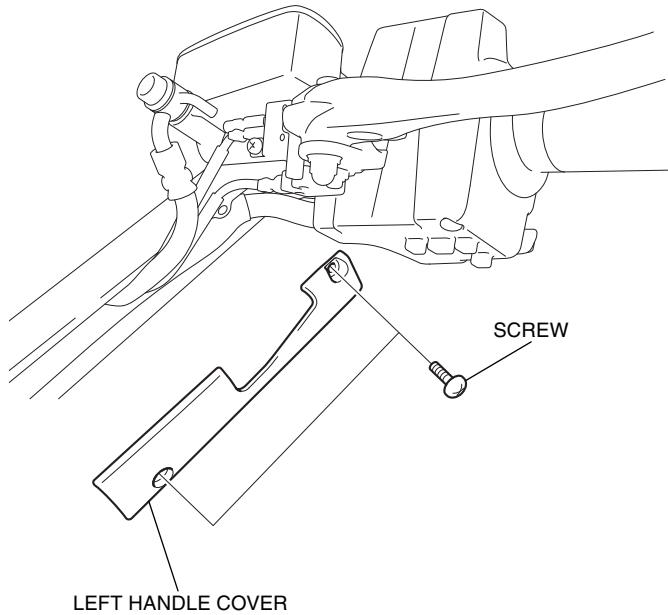

16. Remove the handlebar weight from the motorcycle's right grip as shown.

- Repeat on the left side.

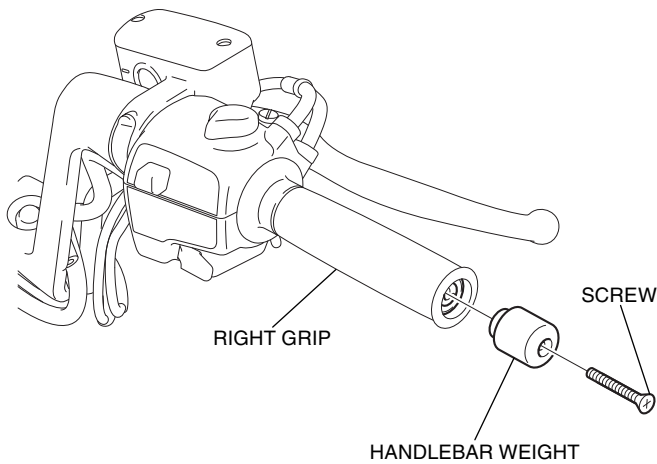

17. Remove the screws from the right handle switch holder as shown.

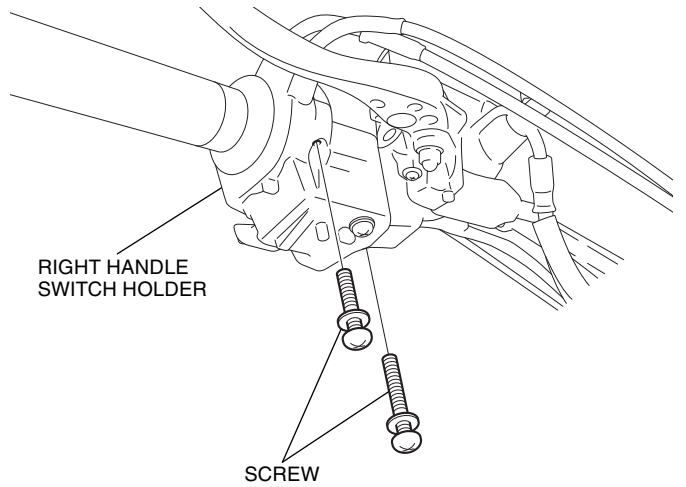

18. Remove the right grip as shown.

**NOTE**

Refer to the motorcycle's Service Manual and disconnect the throttle cable from the right grip as instructed. Do not try to disconnect the cable with force using pliers or other tools.

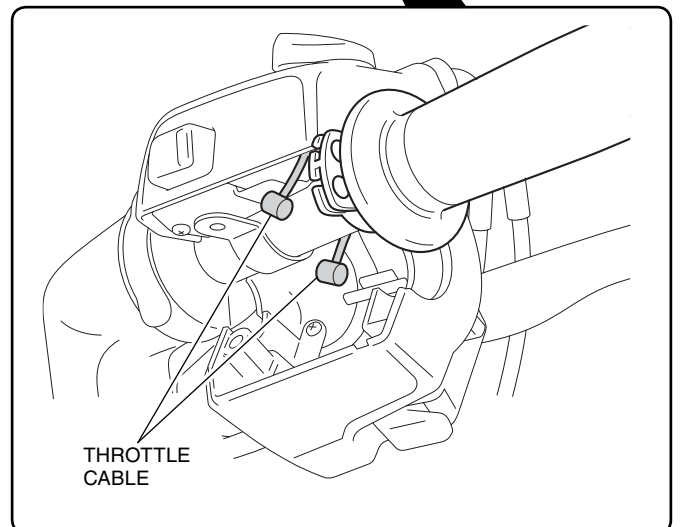
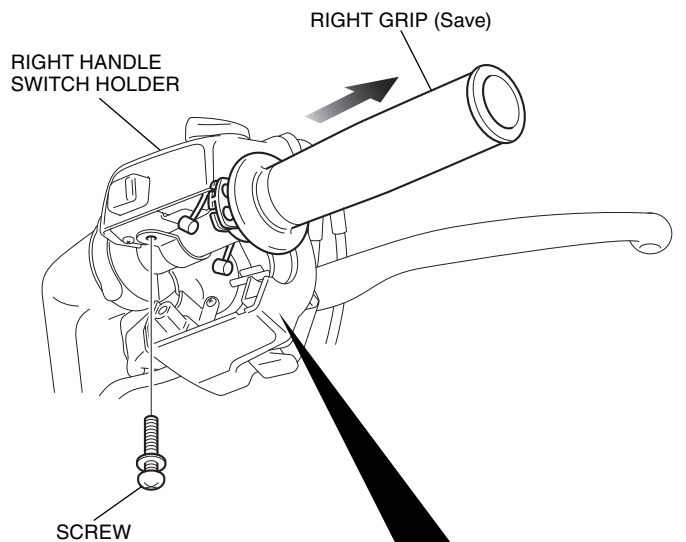

19. Apply grease to the  parts of the throttle cables and throttle pipe as shown.

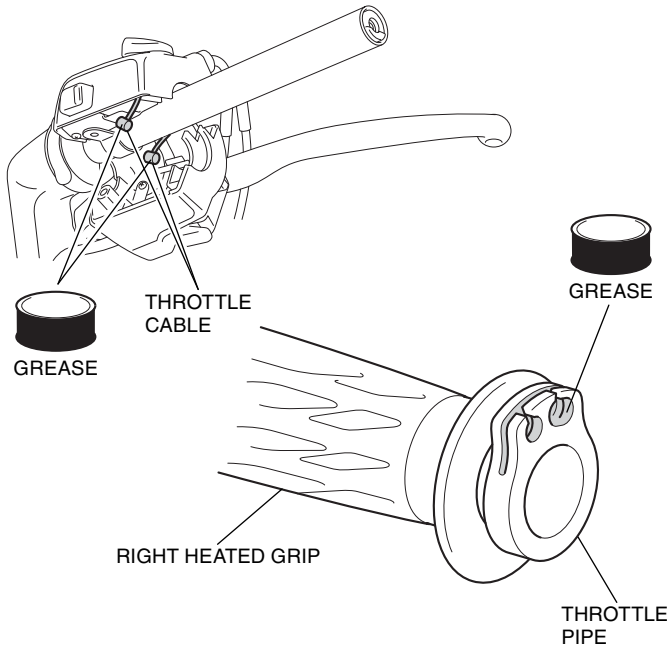

20. Install the right heated grip and right handle switch holder in the reverse order of the removal.

- **After installation, refer to the Service Manual and adjust the throttle freeplay.**

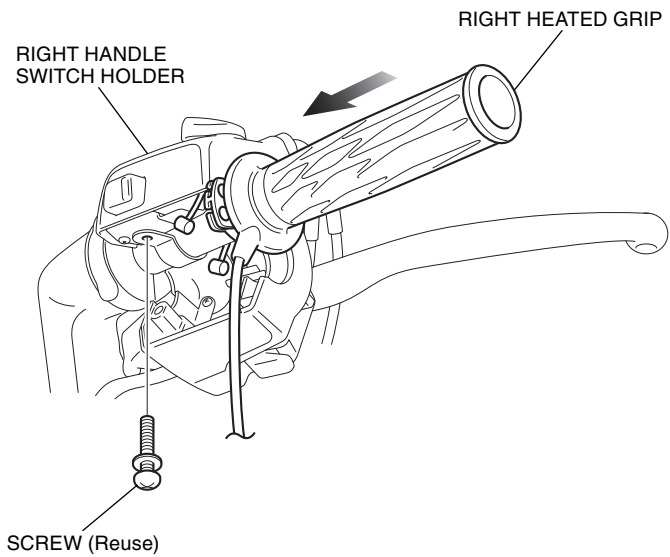

21. Remove the screw and loosely install the clamp to the right handle switch holder as shown.

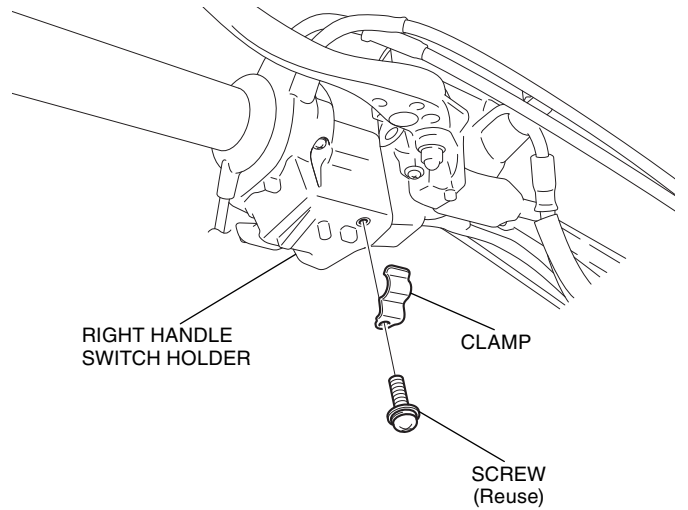

22. Secure the right heated grip harness as shown.

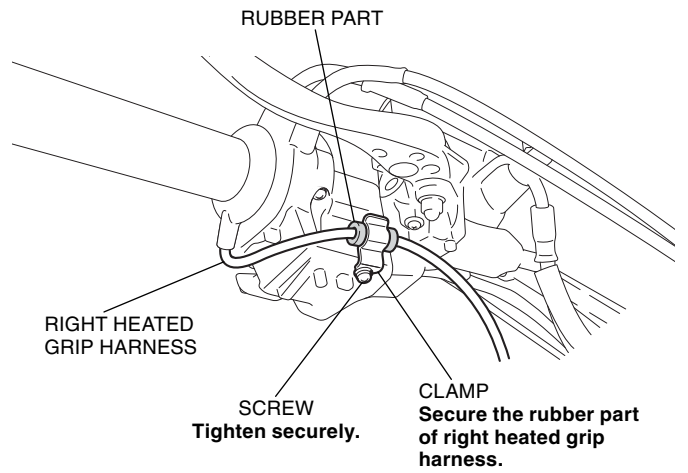

23. Twist the throttle grip as shown.

- **Check for smooth opening of the throttle and that it automatically snaps closed from any opening, in all steering positions.**

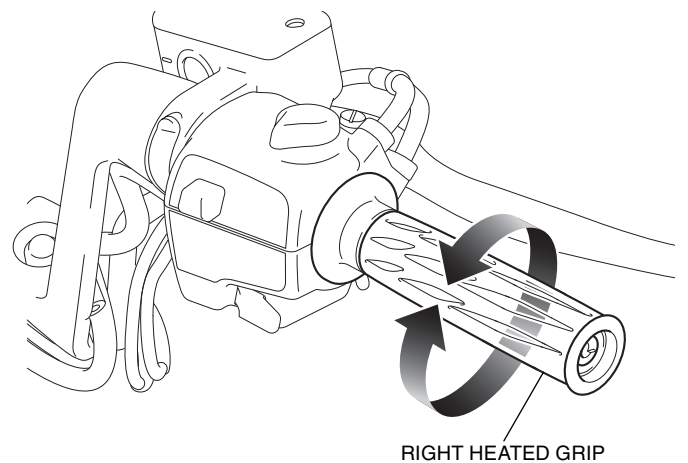

24. Route the right heated grip harness as shown.

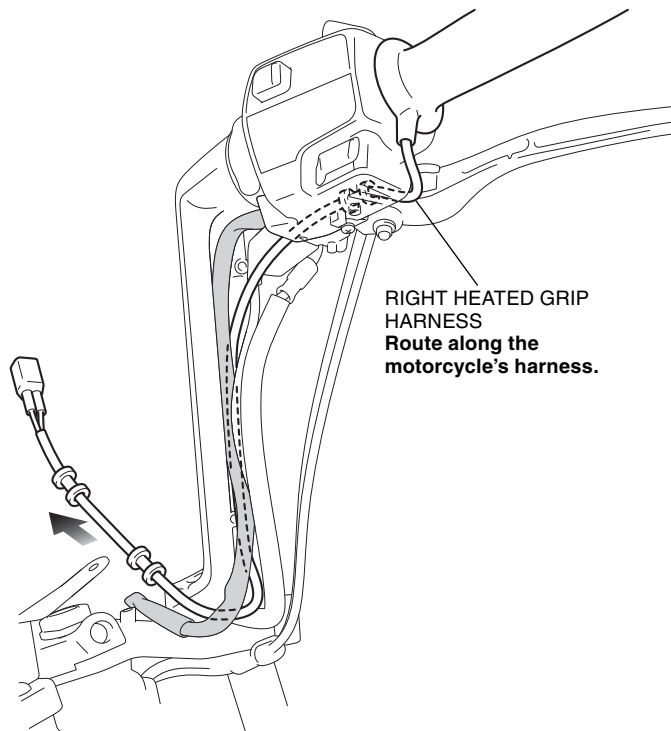

25. Install the right handle cover in the reverse order of removal.

26. Remove the left grip as shown.

<Left side>

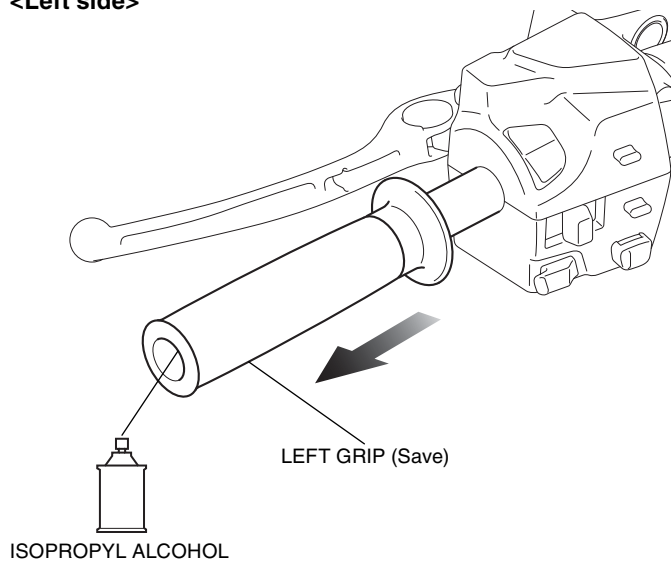

27. Using isopropyl alcohol, remove all traces of adhesive from the left handlebar.

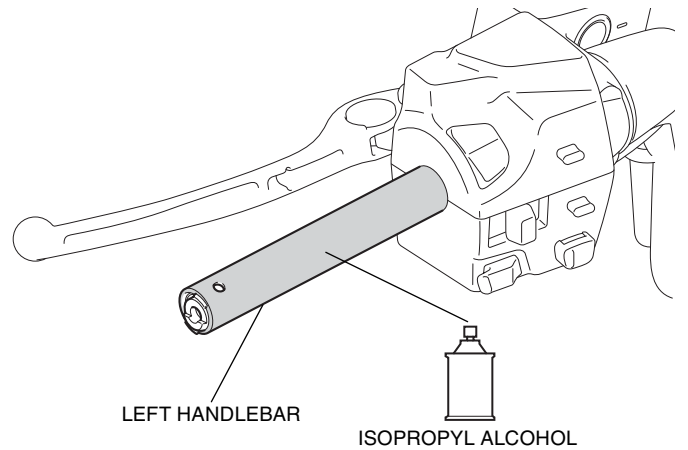

28. Liberally apply the Honda bond A to the inside of the left heated grip from the kit as shown.

**NOTE**

Read the Instructions of the Steps 28 through 31 carefully before operation and complete the installation quickly before the adhesive agent cures. Use an assistant to steady the motorcycle while installing the grips.

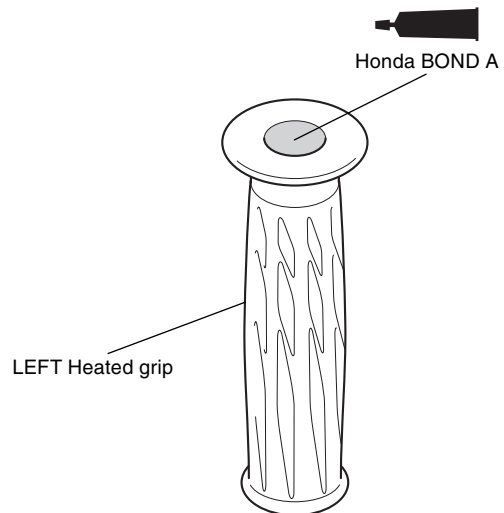

29. Apply the Honda bond A to the left handlebar as shown.

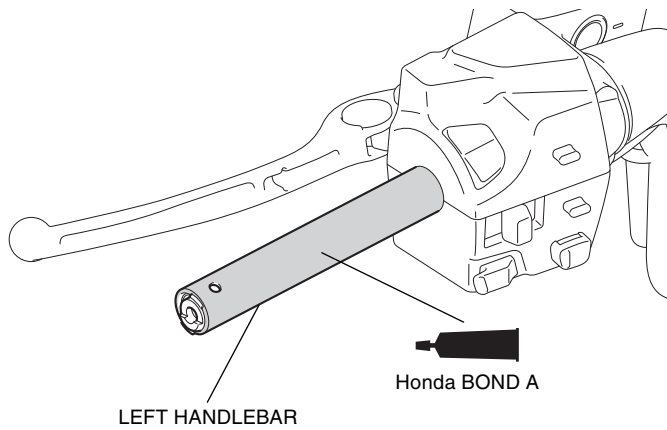

30. Spray isopropyl alcohol over the inside of the heated grip and outside of the left handlebar.

- This is done to ease alignment between the heated grip and the handlebar.

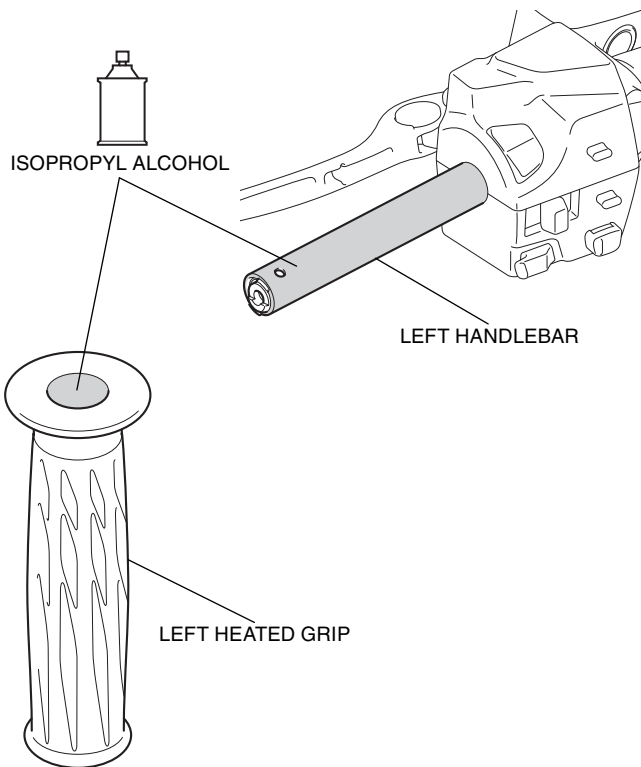

31. Slide the left heated grip onto the left handlebar as indicated.

- Wipe up excess adhesive at once.

**NOTICE**

- Do not tap on the grip end with a hammer and do not twist the grip to install the heated grip onto the handlebar, as it can damage the heating element.

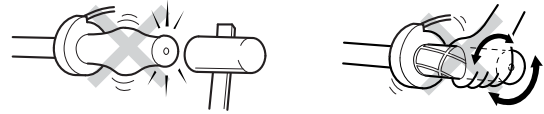

- If the grip gets stuck halfway during installation, apply isopropyl alcohol between the heated grip and handlebar. Do not try to remove the heated grip using force or tools as heating element can be damaged.

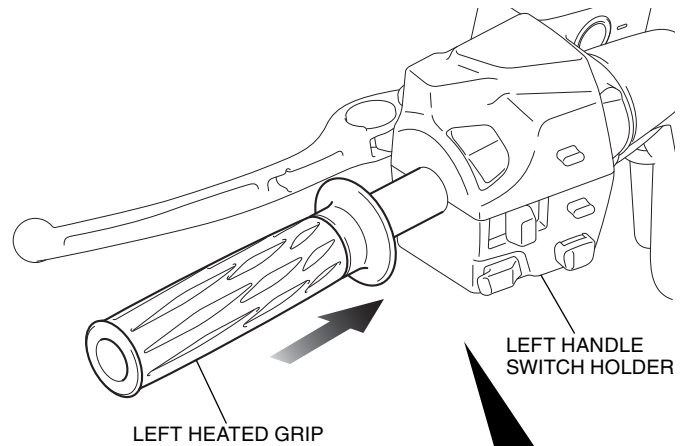

**Install the left heated grip in the position shown.**

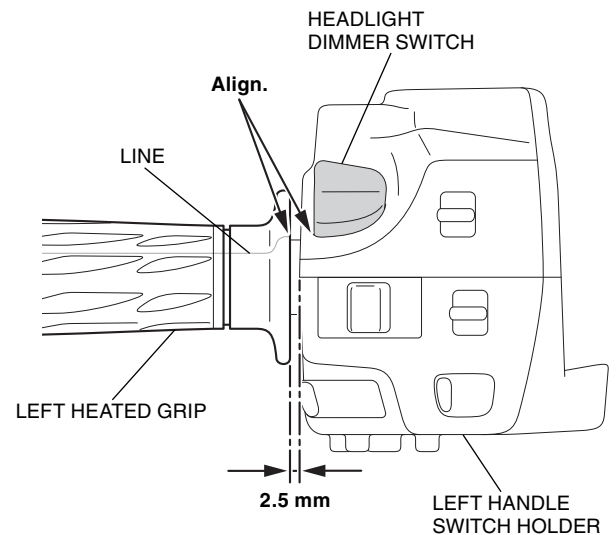



32. Remove the screw and loosely install the clamp to the left handle switch holder as shown.

<Left side>

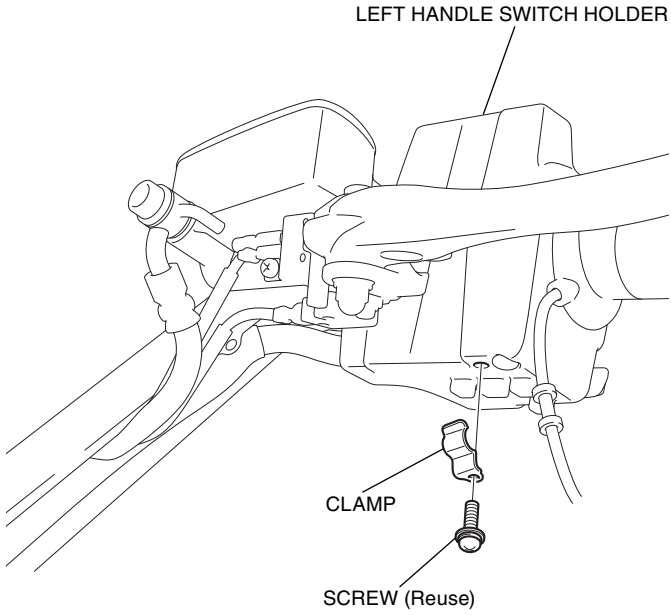

33. Secure the left heated grip harness as shown.

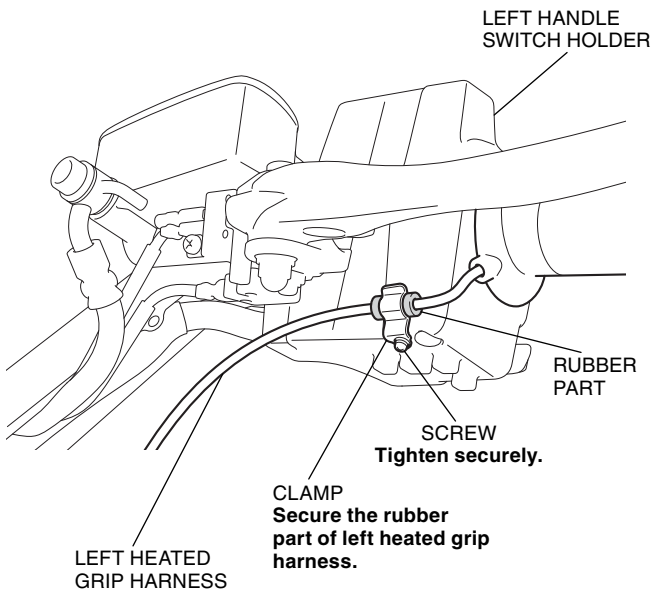

34. Route the left heated grip harness as shown.

<Left side>

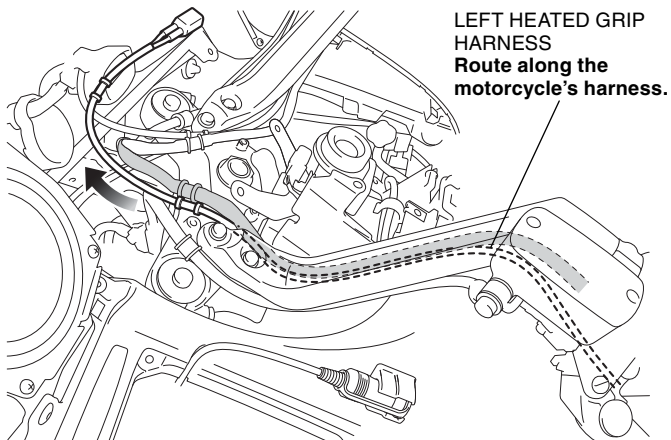

35. Install the left handle cover in the reverse order of removal.

36. Install the front brake hose guide as shown.

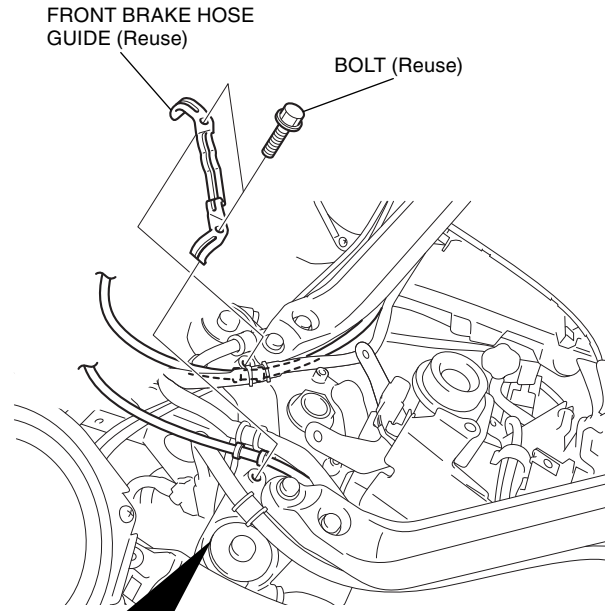

Secure each harness in the position shown.

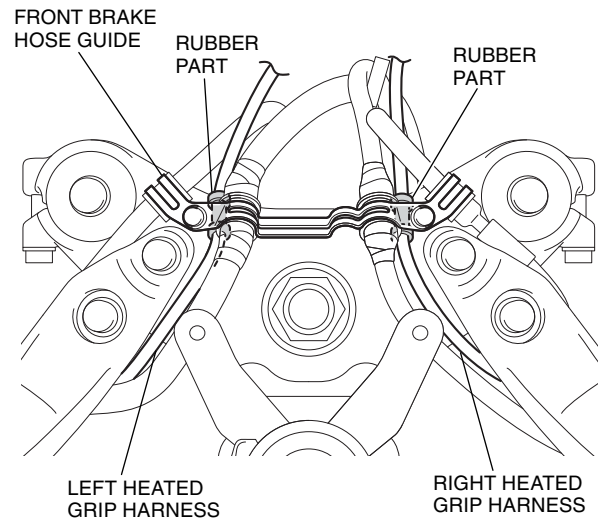

37. Route the right and left heated grip harnesses as shown.

<Right side>

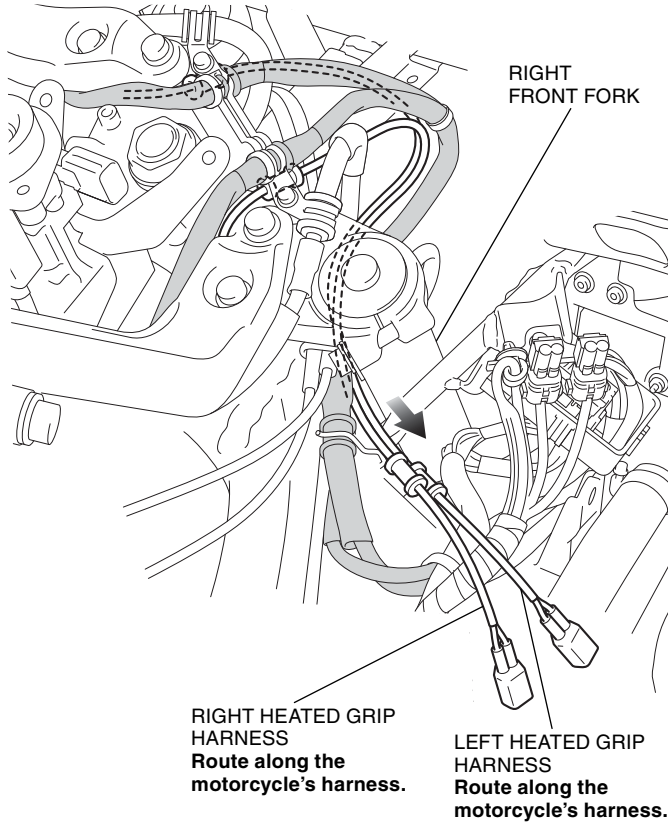

38. Remove the motorcycle's connectors from the stay as shown.

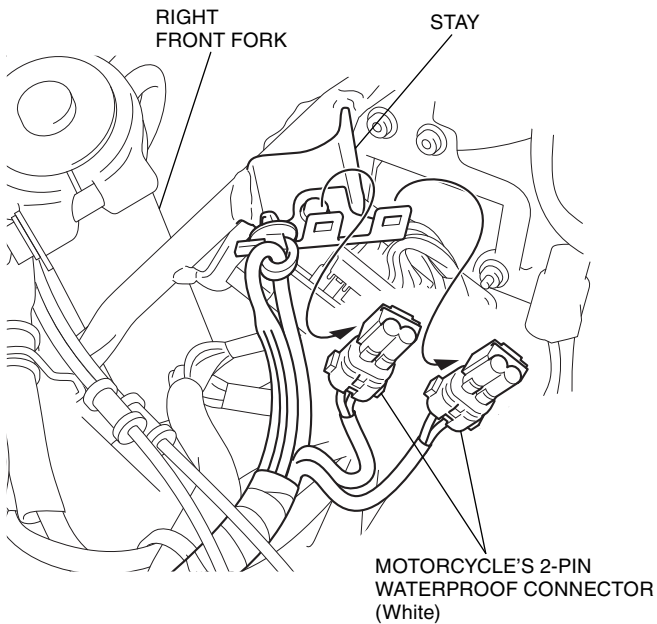

39. Remove the dummy connectors and the electrical tape from the motorcycle's harness as shown.

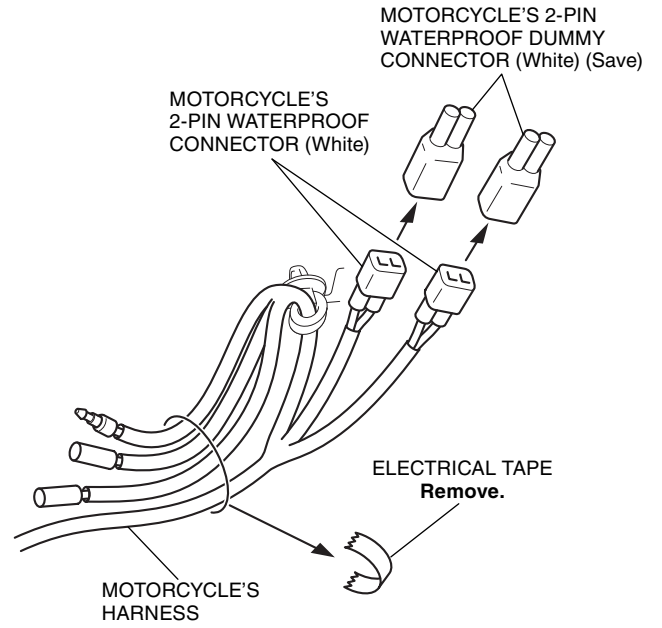

40. Route the right and left heated grip harnesses, and connect them as shown.

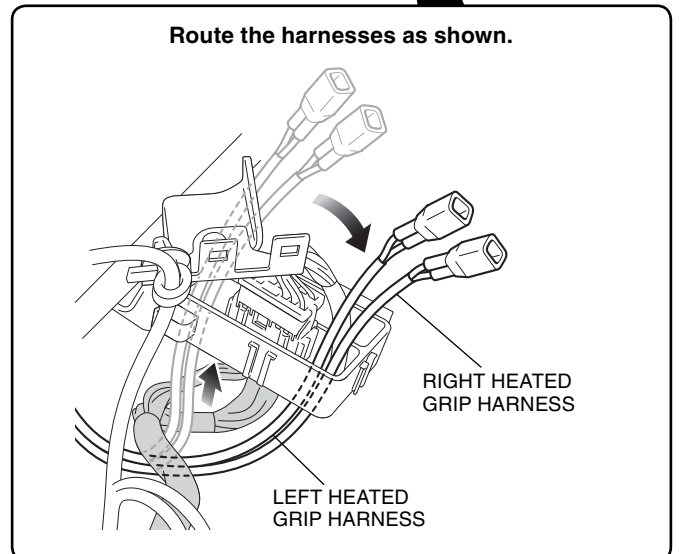
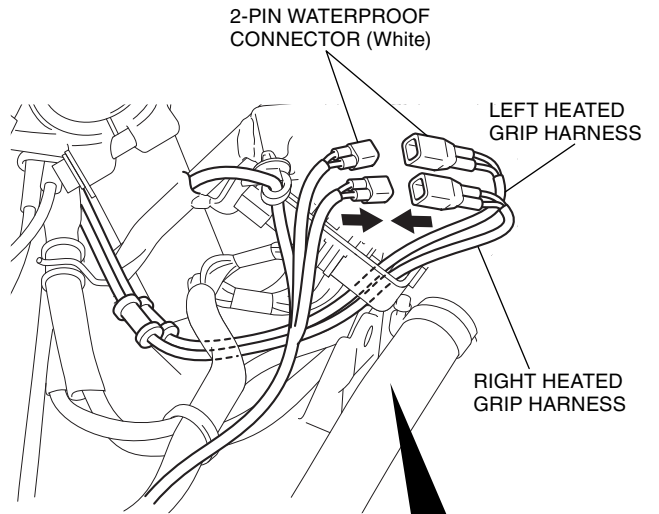

41. Secure the connected connectors to the stays.

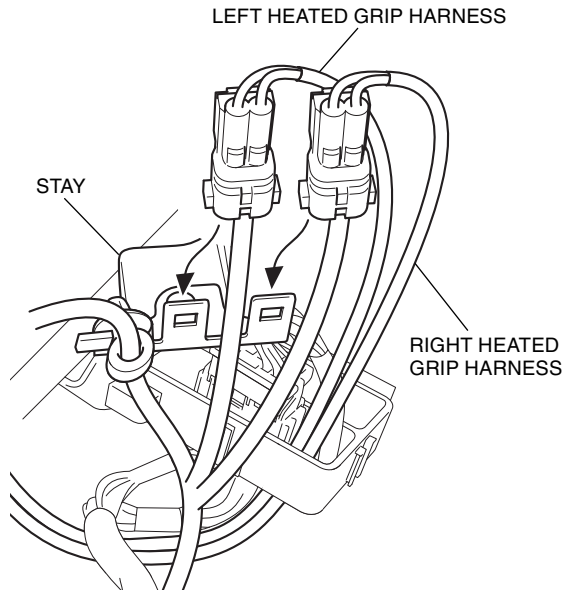

42. Secure the right and left heated grip harnesses as shown.

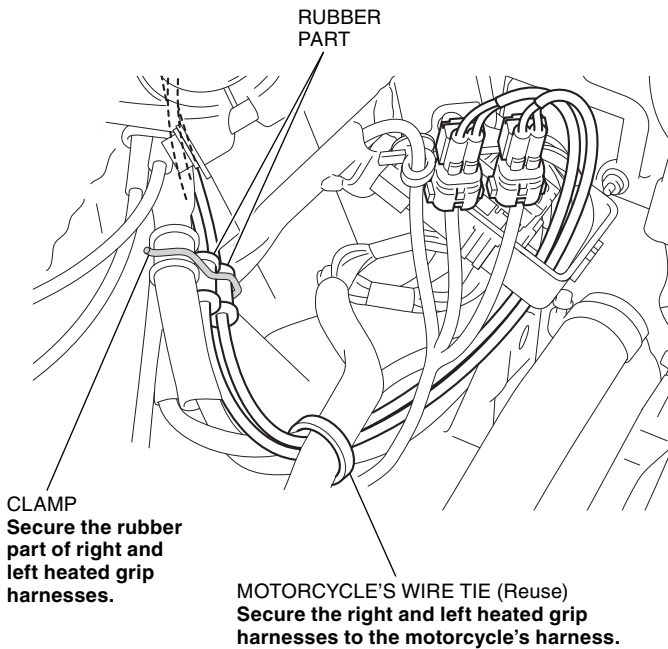

43. Secure the right and left heated grip harnesses as shown.

- Move the handlebar right and left and check that the harnesses are not pinched by the neighboring components and that they are not pulled taut.

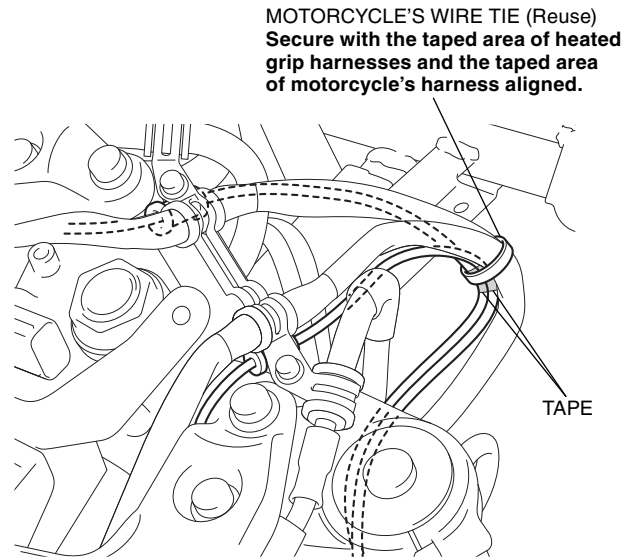

44. Reinstall the right handlebar weight as shown.

- Repeat on the left side.
- Clean up with isopropyl alcohol before applying thread lock.
- Be sure to apply threadlock to the threads of the screw.

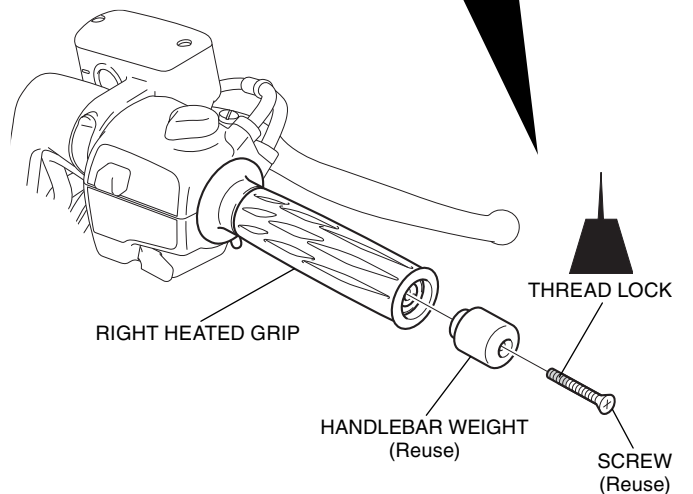
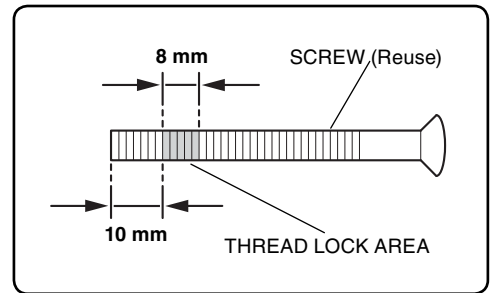

45. Mark the heater switch harness in the position shown.

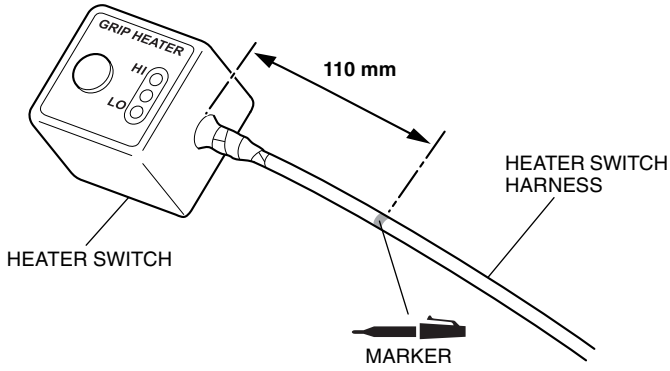

46. Assemble the heater switch as shown.

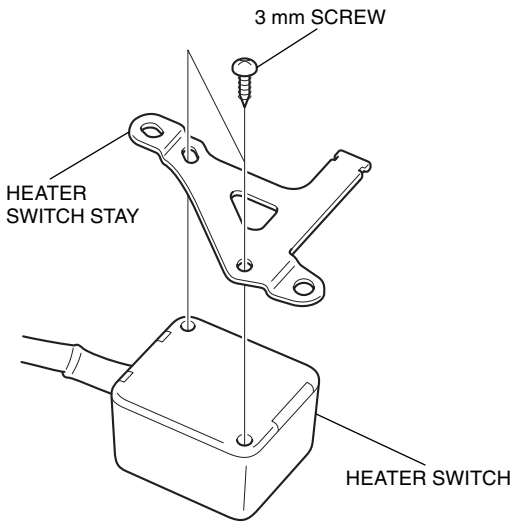

47. Secure the heater switch harness with the wire tie as shown.

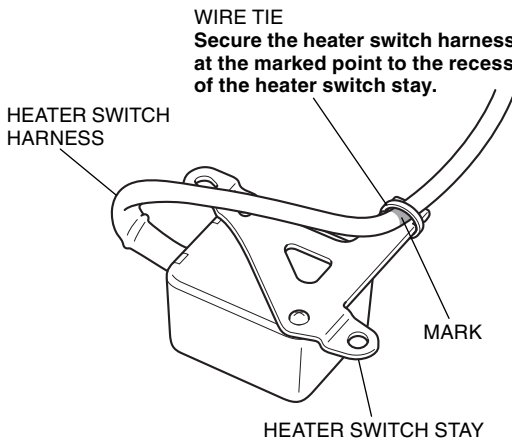

48. Install the assembled heater switch as shown.

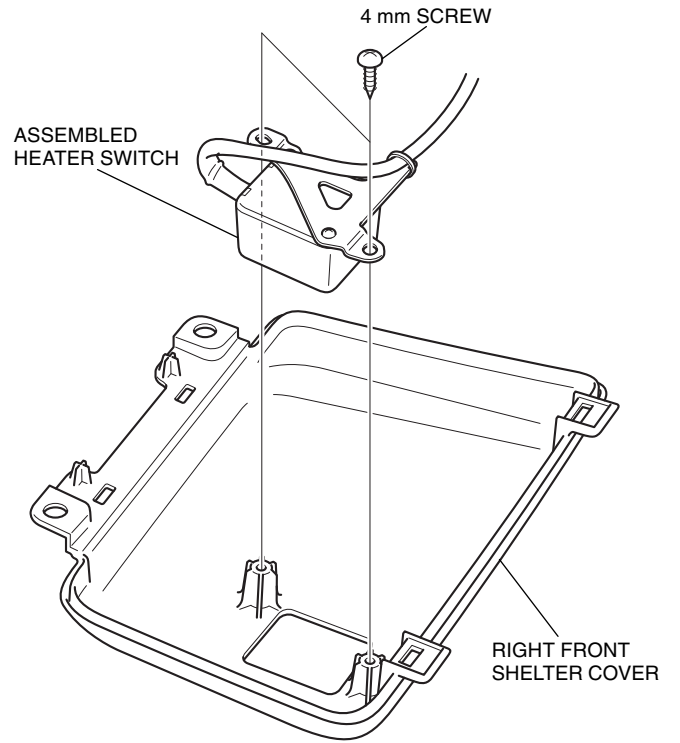

49. Install the right inner cover, right air cleaner intake duct and right top shelter in the reverse order of removal.

50. Connect the heater switch harness and install the right front shelter cover in the reverse order of removal.

- Confirm that any wire harness is not caught or too tight.

<Right side>

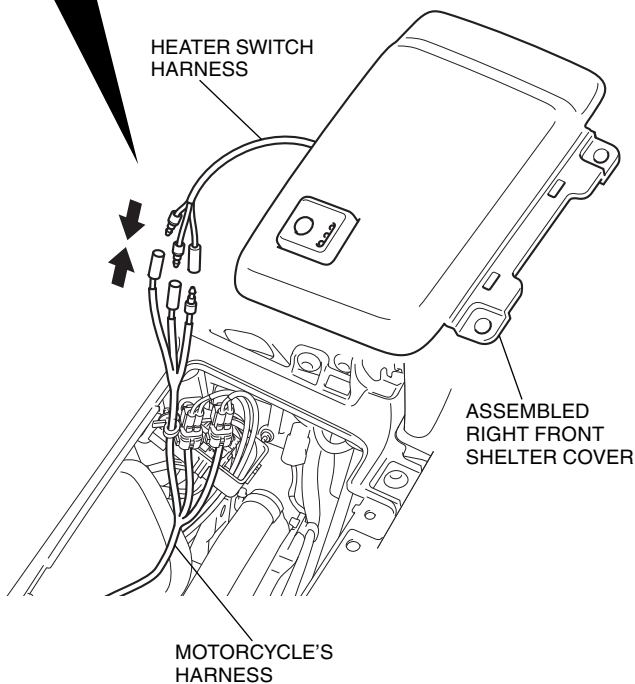
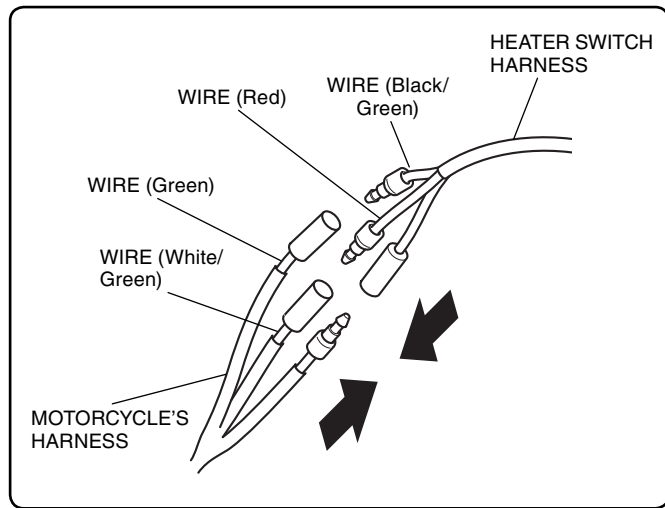

51. Install the motorcycle's parts in the reverse order of removal.

- Confirm that any wire harness is not caught or too tight.

## DEALER TROUBLESHOOTING

- Stop the engine and turn the ignition switch OFF when you check the parts and circuits other than those of the heated grips.

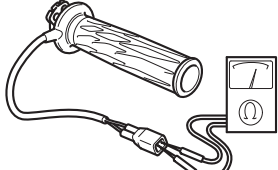
Symptom	Check
Heated grips do not operate; • Faulty heated grip • Faulty heated grip coil • Blown fuse • Open or short circuit in heater harness • Faulty heater switch	1. Check whether wires and cables (terminals and connectors) are connected securely. 2. Heated grip inspection Check for resistance between the terminals. ➔ Standard: Right : 2.2 ohms +/- 10% Left : 2.2 ohms +/- 10%  3. If no abnormality is found after the above checks 1 and 2, but the heated grip still does not operate properly, replace the heater switch with a new one. • It is hard to check the switch with ordinary inspection methods (for continuity, voltage etc.) because it contains an integrated circuit.