

IMPORTANT SAFETY INSTRUCTIONS

INSTALLATION, OPERATING AND SERVICE MANUAL

READ AND FOLLOW ALL INSTRUCTIONS

BADU®JET

Counter Swimming Unit
U.S. Patent No. 3.977.027
OWNER'S MANUAL



For Swim Jet Use Only - 400 GPM -
Swim Jet Combination Fitting
Life: 10 Years - Wall Only - Badu@Jet

VGB 2008



Complies with UL 1563
Swimming Pool Equipment
Listing #E212148

All parts are manufactured of corrosion-resistant material and combined in one single housing that can be installed in pools of any size and shape.

Key to illustration:

- A.** Flush mounted Jet Housing, 16" in diameter
- B.** Rectangular, Anti-Entrapment Cover (20" x 17") for undetectable pump suction. (Optional Round)
- C.** Adjustable Water Flow Jet Nozzle
- D.** Water volume control knob adjusts force of water leaving jet nozzles
- E.** Pneumatic on/off button guarantees complete electrical separation between pool water, pump motor and control box.
- F.** Air regulator adjusts amount of air bubbles in water flow.
- G.** Control box with GFCI with tubing for pneumatic button.
- H.** Speck 4 HP self-priming, plastic pump, single phase with thermal overload (no motor starter required). Optional three phase motor and control box available (Normal priming pump available for installation below water level).
- I.** Massage Hose with pulsator may be attached to jet nozzle.

TABLE OF CONTENTS

1. Important Safety Instructions	Page 2
2. Introduction and Planning	Page 2
3. Plumbing for BADU[®]JET	Pages 2-3
4. Concrete or Gunitite Installation	Page 4
4a. Installing BADU[®]JET in Existing Gunitite or Concrete Pool	Page 5
5. Liner and/or Fiberglass Pool Installation	Page 6
5a. Removal of Liner	Page 6
6. Installation of Nozzle Housing	Page 7
7. Installation of Anti-Entrapment Cover	Page 7
8. Installation of the Pump and the Control Box	Page 8
9. Operation Instructions	Page 8
10. Nozzle Adjustment Instructions	Page 9
11. Winterizing	Page 9
12. Frequently Asked Questions	Page 10
13. Difference Between the <i>Classic</i> and the super-sport	Pages 10-11
14. Parts List for the BADU[®]JET <i>Classic</i>	Page 12
15. Parts List for the BADU[®]JET super-sport	Page 13
16. Limited Warranty	Page 14

IMPORTANT INSTALLATION TIPS IN BOLD PRINT

*Consult your physician before attempting any strenuous exercise.
This product may not be challenging or satisfying for all levels of exercise.*

1. Important Safety Instructions

When installing and using this electrical equipment, basic safety precautions should always be followed, including the following:

A. READ AND FOLLOW ALL INSTRUCTIONS.

B. ⚠ WARNING: To reduce the risk of injury, do not permit children to use this equipment unless they are closely supervised at all times. Failure to adhere to this and all other warnings could result in serious injury or death.

C. A licensed electrician is required for all wiring connections.

D. TO REDUCE RISK OF ELECTRICAL SHOCK, connect all ground wires to grounding terminal located in the control box. Use no smaller than a No. 12 AWG (3.3mm²) wire.

E. TO REDUCE RISK OF ELECTRICAL SHOCK, a bonding connector is provided on the motor for bonding of local ground points such as water pipes, metal ladders / handrails, or other metal within 5 feet of the pool. All local ground points should be bonded with a No. 8 AWG (8.4mm²) wire. Never use gas piping as an electrical ground.

F. All electrical equipment should be installed in accordance with local codes.

G. DO NOT store or use gasoline or other flammable vapors or liquids in the vicinity of this equipment. **DO NOT** store pool chemicals near the equipment.

H. DO NOT remove any safety alert labels such as **DANGER**, **WARNING**, or **CAUTION**. Keep safety alert labels in good condition and replace missing or damaged labels.

I. Keep and read all equipment manuals. Adhere to all of their instructions.

J. ⚠ WARNING: Stay alert, watch what you are doing and use common sense. **DO NOT** use unit if you are tired and/or exhausted. **DO NOT** use unit while under the influence of drugs, or alcohol, or any medications.

K. ⚠ WARNING: Consult your physician before exercising with the **BADUJET** or using the massage hose.

L. ⚠ WARNING: DO NOT use or operate the **BADUJET** if the anti-entrapment cover is missing, broken or loose.

M. SAVE THESE INSTRUCTIONS! Refer to them frequently and use them to instruct third party users.



2. Introduction and Planning

The **BADUJET** is normally incorporated into the original pool design. However, it can be added to any pool at a later date.

The **BADUJET** has no protruding parts, and ensuring the pool user's safety. It is very compact and installs at minimal cost.

The **BADUJET** can be installed in any size pool. We suggest a minimum pool size of 7 ft. wide, 14 ft. long and 3 1/2 ft. deep in order to swim. Most prefer 16 ft. in length or longer. The extra length allows the swimmer to comfortably drift back and swim up stream.

Consult local codes for minimum distance between pump and pool. Locate pump as close to the **BADUJET** as practical.

Use at least 4" pipe when distance between jet housing and pump is 30 ft. or less and 6" for pipe runs longer than 30 ft.

The 4 HP, self-priming, plastic pump has a single phase motor with thermal overload (no motor starter required). The 4 HP single phase motor draws a maximum of 19.4 amps @ 230 V. The unit requires a minimum circuit of 30 amps. Install a 40 amp breaker to avoid nuisance tripping when pump is turned on and off frequently. The starting current of the 4 HP motor can reach up to 6 times the running currents. (Three phase motor draws a maximum of 12.8 amps @ 230 V and 6.4 amps @ 460 V).

3. Plumbing for **BADU[®]JET**

The **BADUJET** assembly package contains all necessary parts for the installation of the unit into concrete, gunite, liner or fiberglass pools.

⚠ CAUTION: All necessary screws and bolts included with the **BADUJET** are stainless steel or plastic. **ALL** screw threads and threaded inserts are **METRIC! ONLY METRIC** bolts and nuts may be used! The one exception is the connecting thread

for the intake and delivery connections on the **BADUJET** and pump housing.

⚠ CAUTION: The adaptors on the housing are factory mounted and should never be removed. Removal of these adaptors will void warranty.

⚠ CAUTION: The pressure connection must be located exactly ABOVE the suction connection.

CAUTION: The suction line should run below water level right up to the pump location.

CAUTION: The center of the housing (the nozzle) should be 10" **BELOW** water level for maximum efficiency. The air regulator should be approximately 4" **ABOVE** the water level. (See fig. 1)

CAUTION: For trouble-free pump priming (up to 4 ft.) first install a 6" riser on top of the pump. Then install an elbow and lead the pressure line downward to the pressure connection at the **BADUJET** housing.

CAUTION: In areas with soft soil conditions or with frequent earth movement, a flexible section of 4" hose should be attached to the back of the jet housing to prevent plumbing breakage.

CAUTION: Throughout the entire installation, make sure plumbing connected to the **BADUJET** housing is well supported. Unsupported plumbing will crack the **BADUJET** housing.

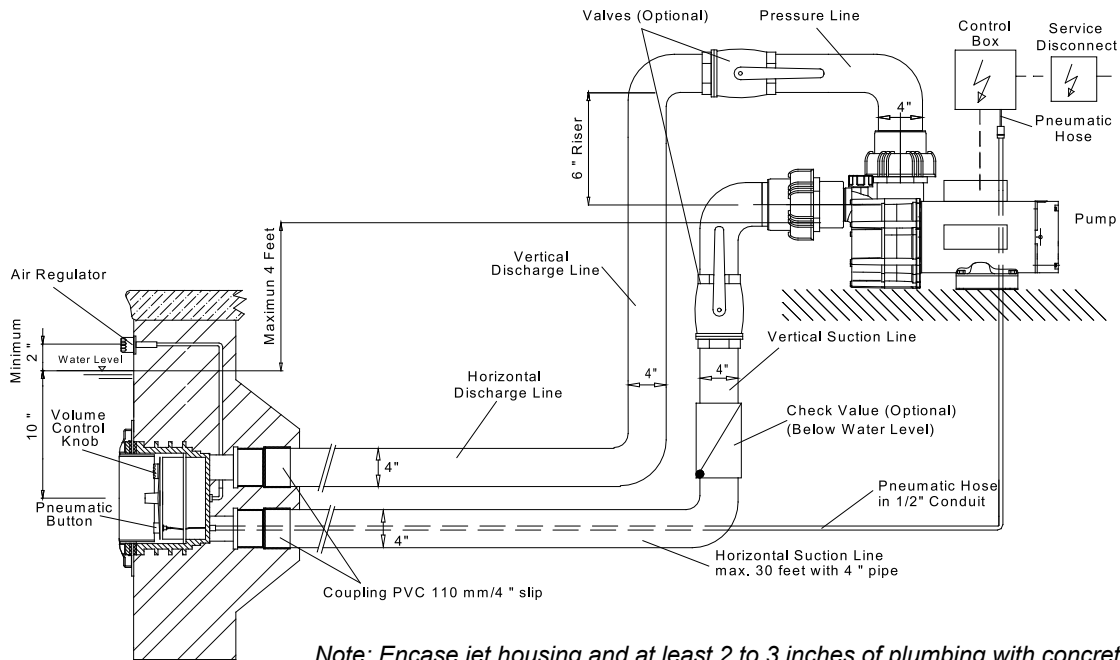

Fig.1

*Note: Encase jet housing and at least 2 to 3 inches of plumbing with concrete.
Note: Valves are recommended when pump is installed below water level.*

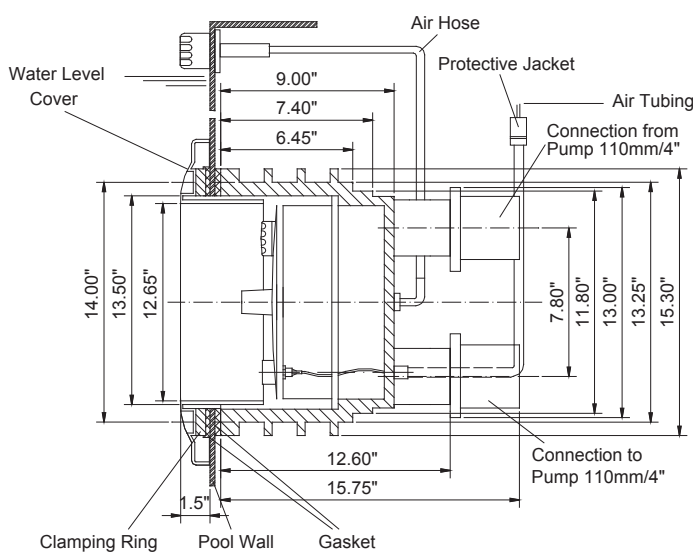

Fig.2

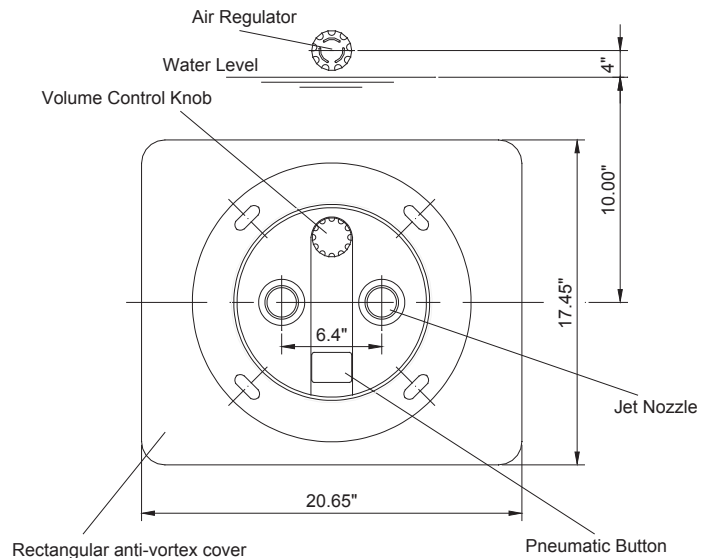

Fig.3

4. Concrete or Guniting Installation

A. Pre plumb **BADUJET** housings.

1. Install the two PVC SCH 80 couplings 110mm/4" slip (part #2a) on the PVC SCH 80 fittings 110mm (part #2) which are premounted on the jet housing.

2. Install approximately 12" of 4" SCH 40 pipe to both suction and discharge couplings on the jet housing. NOTE: If plumbing exceeds 30' between jet housing and pump, increase pipe size to 6". Install a 6 x 4" reducing bushing as close to jet housing as possible.

3. Install approximately 18" of 1/2" conduit to back of jet housing. (Conduit connector part #3).

4. Install air control PVC hose (part #7) and Y socket (part #6) assembly to hose socket insert fittings (part #4). Use hose clamps (part #8) to secure hose to insert fitting.

B. Mount the protective cover plate (part #30) to jet housing using stud bolts M8 x 80 (part #31). Tape edge of cover plate to jet housing. The cover plate and stud bolts are solely used for installation and can be discarded afterwards. Keep concrete out of threaded inserts and out of the inside of the housing.

C. Place jet housing into reinforced steel (see fig. 7). Jet housing location is very important.

1. Locate pressure connection exactly above the suction connection.

2. The center of the housing (the nozzle) should be 10" **BELOW** water level for maximum efficiency.

3. Front edge of Jet housing should finish even with inside guniting wall. Make sure a V shaped groove is scraped out

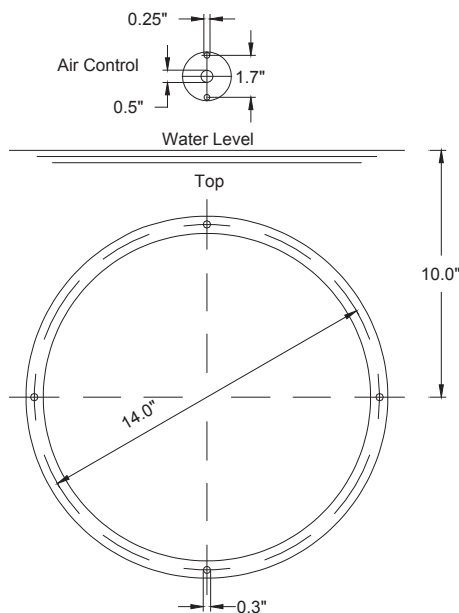

Fig. 4

Template for Installation in Guniting or Concrete Pools.

around the housing approximately 1 1/2" deep to allow marcite to seal against the housing.

4. Recheck location of Jet housing when guniting is being applied. The force of the guniting may move the jet location.

5. To avoid stress on the jet housing, we recommend that the **BADUJET** housing be encased with guniting and at least 2 to 3 inches of the plumbing stub out is covered with guniting.

NOTE: Stress on the plumbing may crack the **BADUJET housing.**

D. Air regulator installation should be approximately 4" ABOVE the water level.

1. Air regulator holder (part #9) and hose socket insert fitting (part #5) connect to PVC hose (part #7). Make sure air regulator holder face is tapped over to prevent guniting from entering holder.

2. Air regulator can be located in the tile line above water line or in the deck.

E. Keep all parts not being used now in original box. Store in a safe place until needed.

F. The following is a list of all parts that **ARE NOT USED IN A GUNITING INSTALLATION:**

- | | |
|-------------------------|----------|
| 1. Gasket w/knobs | part #26 |
| 2. Clamping ring gasket | part #27 |
| 3. Counter sunk bolt | part #10 |
| 4. Washer M6 | part #12 |
| 5. Nut M6 | part #11 |
| 6. Counter sunk bolt | part #98 |

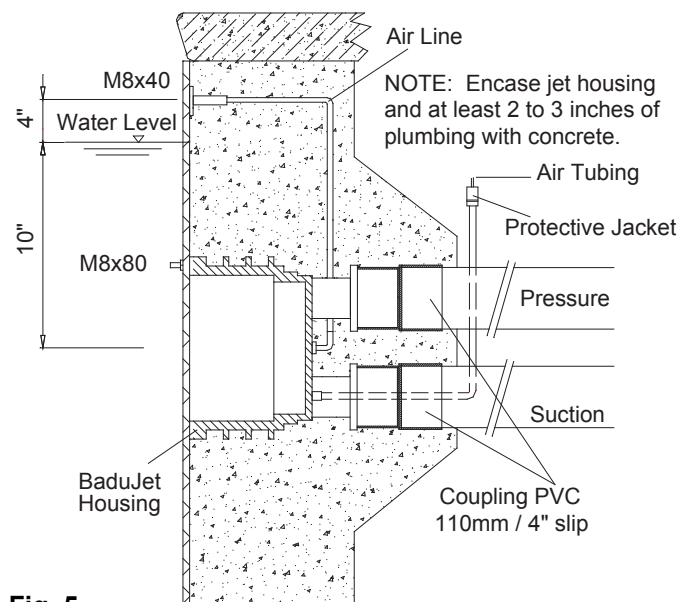

Fig. 5

BADUJET in Concrete or Guniting Pool.

4a. Installing in Existing Concrete or Gunite Pool

Materials: 1 piece of Plywood 2' x 3' x 1/4"
8 Lag screws 1/4" x 1 1/2" (minimum)
8 Plastic lag anchor shields

Step 1. Carefully choose the location in which **BADUJET** is to be installed; it should be a flat surface with no or very little crown.

With a concrete saw, cut out the outline of the section to be chiseled out with an air hammer or equal. This hole should be 19" wide x 19" down from the water line. The bonding rods on the cap of the pool should be left intact, while all other steel rods should be cut back to clear the placement of the jet housing.

Step 2. Taking the 2' x 3' x 1/4" plywood, set its top edge even to the cap of the pool wall. In some cases a larger piece of plywood maybe needed to cover the hole completely. If plywood covers the hole, mark the water line on the plywood. From this line, layout and drill holes in plywood for the air regulator, the four **BADUJET** housing installation studs, and the eight 1/4" lag screws. NOTE: See Fig. 5a for layout measurements.

Insert installation studs (part #31) in jet housing; one at the top, the bottom of the vertical center line and on each side on the horizontal center line. Place cover plate on studs covering the inside of the jet housing. Next place plywood on the studs and secure with washers and nuts.

Now place this assembly into position in the pool wall and align the water line marks. With a level on the two horizontal studs, level the assembly and mark the 8 holes for the 1/4" lags. Remove assembly and drill holes for lag anchors. Reposition the assembly and secure lags. It is best to check with a level before tightening the lags down. Back fill and form the outside of pool wall.

Step 3. Mix compound that is compatible and has good bonding characteristics to the pool wall compound. Pour mixture into form. Use a mallet and lightly tap the front of formed assembly to settle mixture, and avoid any air bubbles in the pour. It should be filled to the top of the plywood. Let mix cure and then remove plywood form and cover plate. Drill out plastic lag anchors and feather in pool wall finish. Replace tile and coping. Remove assembly studs and install nozzle housing and anti-entrapment cover. (See Sections 6 & 7)

Throughout the entire installation, make sure the plumbing connected to the **BADUJET** housing is well supported. Unsupported plumbing will crack the **BADUJET** housing. To avoid stress on the plumbing, we recommend that the **BADUJET** housing be encased with gunite and at least 2 to 3 inches of the plumbing stub out is covered with gunite. Stress on the plumbing may crack the housing.

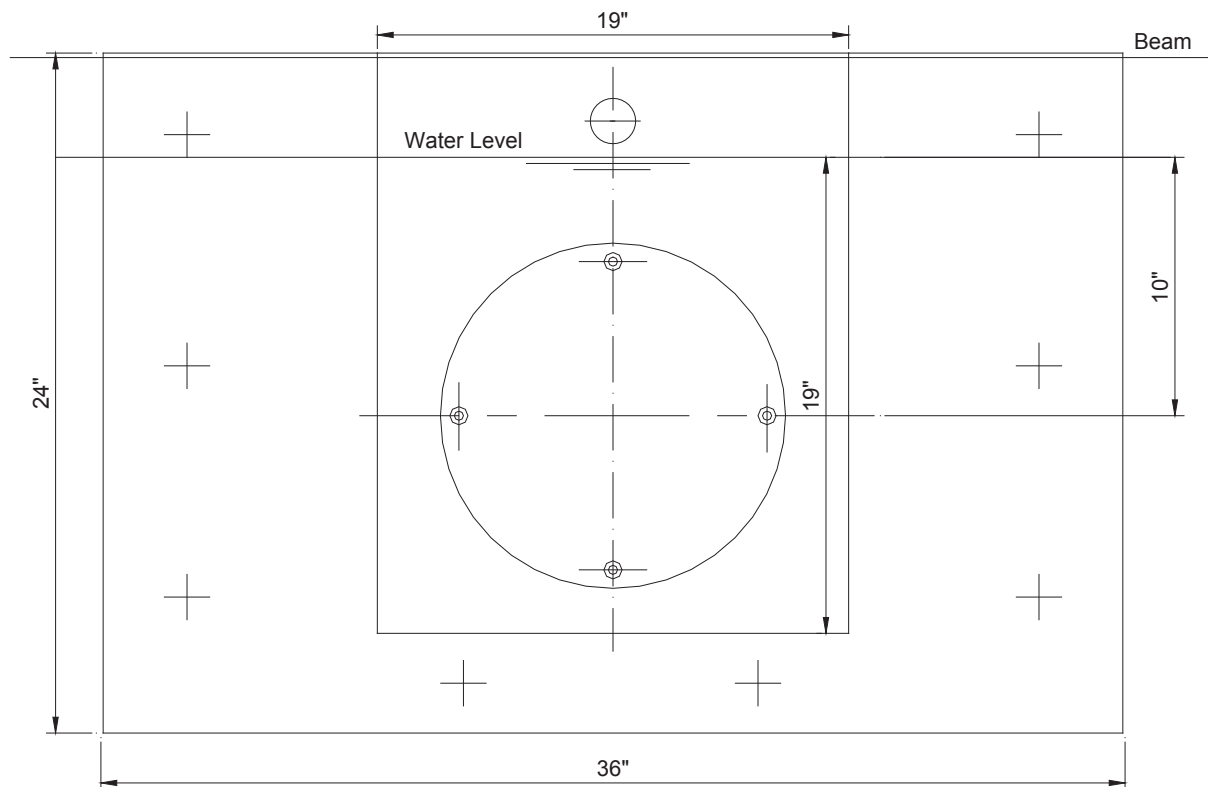

Fig. 5a
Layout for installing in existing gunite or concrete pools.

5. Liner and/or Fiberglass Pool Installation

CAUTION: Locate pressure connector exactly above the suction connection. Pressure and suction connectors must be exactly vertical or the rectangular cover will be uneven in appearance.

CAUTION: Center of housing (the two nozzles) should be 10" **BELOW** water level for maximum efficiency.

CAUTION: Gasket with knobs (part #26) goes **BEHIND** pool wall.

CAUTION: Clamping ring gasket (part #27) goes in **FRONT** of pool wall. A good RTV silicone may be used with gasket when mounting jet housing, but in most cases is not necessary. Installer should decide whether or not silicone is necessary.

The template provided should be used to mark and drill the holes as shown in fig. 6. For the air regulator, one 1/2" hole must be provided, preferably along the vertical axis, approximately 4" **ABOVE** the water line.

For Liner pools only, two additional 1/4" holes need to be made on either side of the 1/2" hole. (see Fig. 6)

Use the two countersunk bolts M6 (part #10), two nuts (part #11), and two washers (part #12) to fasten holder to wall with bolt heads on poolside and nuts on backside. This will keep the holder attached to pool wall for liner installation or replacement. **NOTE:** Gasket (part #13) with larger holes on the outside, fits over screw heads between inside of pool wall and liner. This gasket may be held in place with silicone during liner installation.

NOTE: The list below shows all parts that ARE NOT USED IN A FIBERGLASS/VNYL LINER INSTALLATION:

1. Cover Plate part #30
2. Stud Bolt M8 x 80 part #31
3. Washer M8 part #32
4. Nut M8 part #33

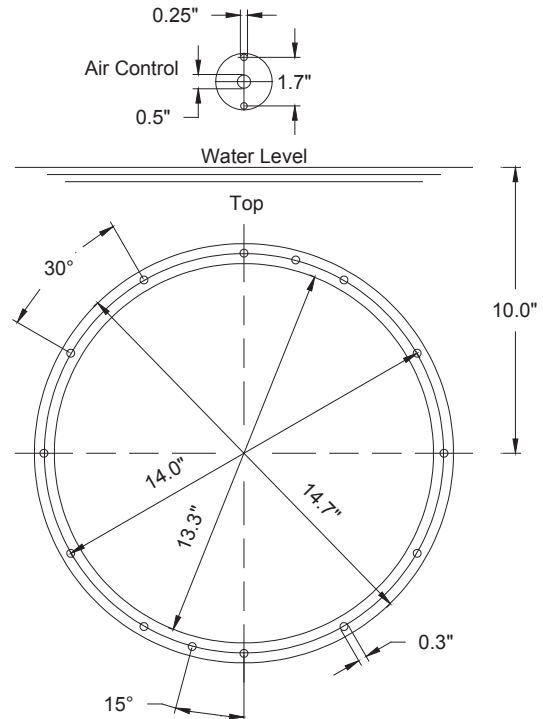

Fig. 6 Cutout in Pool Wall 13.3" for **BADUJET** Housing. The two holes at 15° from the vertical axis and the two holes at the air regulator will allow both housing and air regulator to be mounted with countersunk screws (M8 jet housing / M6 air regulator) before the liner is place.

5a. Removal of Liner

When replacing liner or removing liner for repairs; remove 4 bolts (part #95) which hold square cover (part #93) to jet housing. Remove all bolts (part #29) except top two, which hold the clamping ring (part #28) and gasket (part #27) to jet housing. Back out the two remaining bolts approximately halfway and check for any movement of jet housing from the wall. (NOTE: If the two counter sunk bolts (part #98) which hold the jet housing to the wall were installed, the jet housing should not move, and the two

remaining bolts can be removed.) Remove one of the remaining two bolts and slide clamping ring (part #3) to the side. Replace all the bolts before removing the last bolt. Remove or replace liner. Reverse process to install liner.

NOTE: When replacing clamping ring and bolts: locate bolt heads under liner, make small cut on liner at the bolt heads and push liner over bolt head.

6. Installation of Nozzle Housing

Make sure **BADUJET** housing and threaded inserts are clean. Nozzle housing can be mounted once pool is complete. Pull the volume control knob off the spindle (snap connection). Remove nozzle cover.

Unscrew control disk (part #63) from control spindle. Slide disk on to the 4 prongs at the top of the housing in front of the pressure connection.

VERY IMPORTANT: Make sure shaft side of disk faces nozzle housing (part #53).

Connect air tubing (part #47) to air button (part #38/1) and secure with stainless steel clamps provided. Use end crimper/cutter to gently tighten clamps. **DO NOT OVER-CRIMP.**

Insert preassembled nozzle housing with jets and control spindle counter-clockwise into the regulator disk.

Important: Make sure the end of the 1/2" PVC conduit containing the air tubing ends above the water level and is sealed off with gasket and nut (parts # 16-20) to avoid air intake through the conduit.

Important: Use ALL screws & bolts to guarantee absolute stability. Tighten all screws and bolts snugly. Insert screws & bolts carefully to avoid damage to the inserts.

Attach cover plate to nozzle housing with the 5 self tapping screws (part #49). The volume control knob and cap for air button can now be snapped into place.

7. Installation of Anti-Entrapment Cover

CAUTION: This unit has a rectangular, anti-entrapment cover. Mount rectangular cover onto the clamping ring (part #28) with four (4) bolts (M8 x 20) and cover the openings with the rectangular covers (part #96).

OPTIONAL - Original round style, double ring, anti-entrapment cover available for curved pools walls.

CAUTION: (For original round style, double ring, anti-entrapment covers only.) This unit is equipped with two ring covers. The shallow ring with four attached bushings mounts over the deeper ring. Four plastic counter sunk bolts secure the two rings to the jet housing.

The longer stainless steel bolts (M8 x 80) must be used if a distance has to be bridged when tiles are attached to the concrete.

The ring covers should be fastened directly to the **BADUJET** housing with four (4) plastic bolts (M8 x 45).

CAUTION: DO NOT use force when tightening these plastic screws. Allow ring covers to snap into place elastically and snugly. The longer stainless steel bolts (M8 x 100) must be used if a distance has to be bridged when tiles are attached to the concrete.



Fig. 7
Setting the **BADUJET** housing into reinforced steel



Fig. 8
BADUJET Ready for Guniting

8. Installation of the Pump and the Control Box

This section concerns the electric motor and control box only since all other parts, the pump, the jet unit, etc. have complete and absolute separation from the pool water.

⚠ CAUTION: Before installing the Speck Pump, read the entire pump owner's manual found in the pump box.

Consult local codes for minimum distance between pump and pool. Locate pump as close to the pool as practical.

The air button works up to 50 ft. There is 50 ft. of air tubing in the **BADUJET** box. An adaptor (part #81) is provided when additional tubing needs to be used in the event of replacing a section with locally purchased air tubing.

⚠ WARNING: To reduce the risk of injury, do not permit children to use this product unless they are closely supervised at all times.

The wiring of the pool motor and control box should be done by a licensed electrician in accordance with local codes. Be certain that the motor frame and control box are grounded. Motor name plate has voltage, phase, amp draw, and other motor information as well as wiring connection instructions.

BONDING: As required by National Electrical Code Article 680-22, the pump motor must be electrically bonded to the pool structure (reinforced bars, etc.) by a solid copper conductor not smaller than No. 8 AWG via the external copper bonding lug on the pump motor.

GROUNDING: Permanently ground the pump motor and control box using a conductor of appropriate size. Connect to the No. 10 green headed ground screw provided inside the motor terminal box.

NOTE: Do not connect to electric power supply until unit is permanently grounded.

9. Operation Instructions

Remove red filter plug or strainer tank lid on pump and fill pump with water. Replace red filter plug. Push pneumatic button on the **BADUJET** housing. For the first start-up allow approximately 5 minutes for the pump to prime. If the pump has not started priming after 5 minutes, the amount of water in the pump was not sufficient. Add more water.

The **BADUJET**'s volume control knob enables the swimmer to regulate the volume of water released through the jets. Turn unit off before turning volume control knob. (Turn clockwise to reduce flow up to 12 complete 360 degree rotations.)

The swivel nozzles of the **BADUJET** can be positioned in various directions, allowing swimmers to use various swim styles.

To start swimming, jogging or running it is suggested that the two nozzles are pointed slightly inward and slightly upward so that the water "breaks" approximately 3 ft. in front of the **BADUJET**. Start swimming with only minimal force in arms and legs until you feel yourself drifting backwards, then add force and swim upstream until a proper balance is found between force and endurance.

Keep in mind that this unit is designed for balanced workout. Find a pace that you can keep up for at least 20 minutes. Out pacing is always possible. The idea is to continue exercise for an extended period of time. The air

regulator permits a controlled mixture of air into the water flow and creates a unique, invigorating, bubble bath effect. It will also add additional resistance to swim against.

A pulsating massage hose can be attached to one of the nozzles for massages.

Directions for use: Consult your physician before using the massage hose. To reduce the risk of injury, do not permit children to use the massage hose with pulsator unless they are closely supervised at all times. Turn the **BADUJET** off. Close air regulator. Reduce the volume of water by turning the volume control knob clockwise, slide the cap (part #84) on one nozzle and lock into place. Slide cap of massage hose on the second nozzle and lock into place. Hold pulsator and turn the **BADUJET** on. Massage as advised by your physician.

Under certain conditions it is possible that the current "drifts off" the left or the right from the middle due to water bouncing off the back wall. In the event that it interferes with your swimming action, turn unit off for a few minutes and restart.

⚠ WARNING: Do not use or operate the **BADUJET** if the anti-entrapment cover or original round style, double ring, anti-entrapment cover is missing, broken, or loose.

10. Nozzle Adjustment Instructions

When setting the nozzles for basic swimming, it is recommended that you set the nozzles in such a way that each nozzle intersects 4 feet away, while at the same time breaks the surface.

To help set the nozzles in a neutral position, please follow these instructions:

1. Parts required:
 - 2 PVC Pipe - 1 1/2" x 4'
 - 2 PVC Adaptor - 1 1/2" Male x Hose
 - 2 PVC Coupling - 1 1/2" Slip x 1 1/2" Slip

Note: Hose adaptor 1 1/2" MPT x hose and female adaptor 1 1/2" FPT x 1 1/2" slip can be used

2. Glue fittings and pipe
3. Insert each jet adjustment tool into jet nozzle.
4. Move each jet adjustment tool toward each other until each pipe touches at water level.
5. Remove jet adjustment tool.

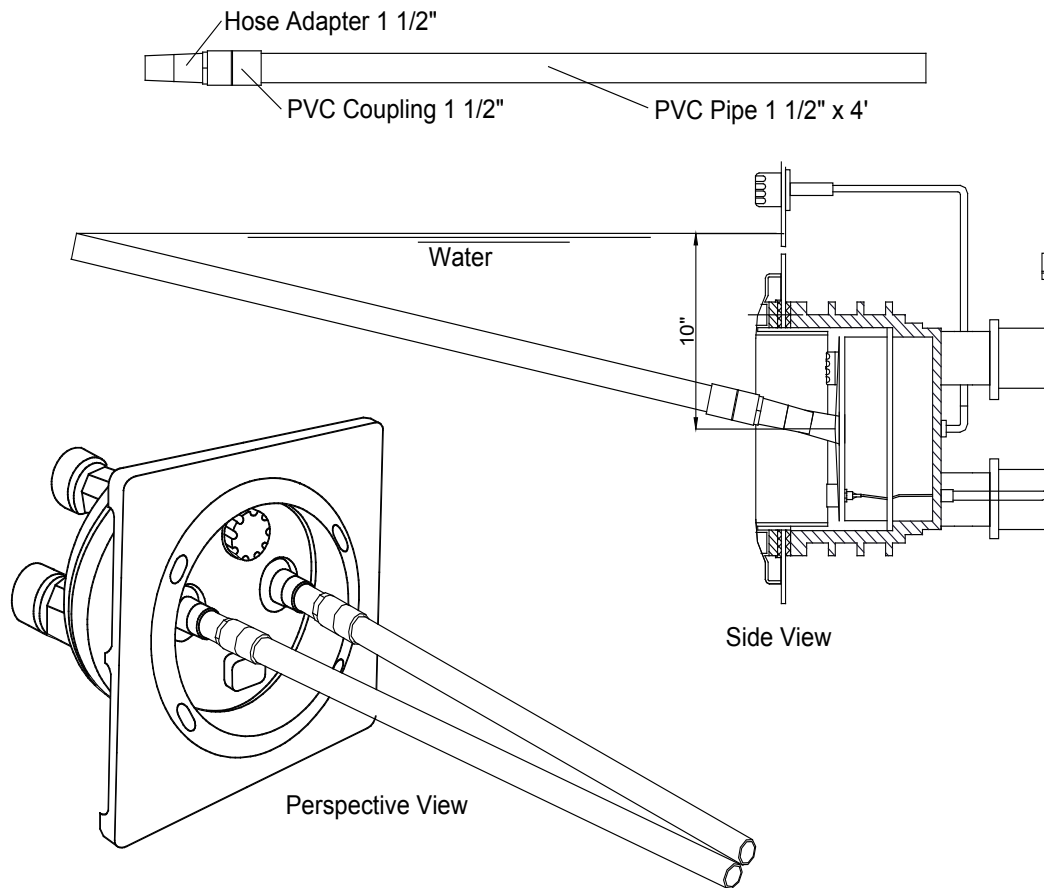

11. Winterizing

In areas subject to freezing water temperatures, you should protect your equipment from the freezing temperatures. You can protect your swimjet system the following:

Drain pool until water level has dropped below the rectangular or round cover (part #93). Then protect pump by removing drain plug and red filler plug (or lid).

12. Frequently Asked Questions

What size pool do I need? The **BADUJET** can be installed in any size pool. However, we recommend a minimum length of 14 ft. and a minimum width of a swimming lane.

What size plumbing is necessary? How far away from the **BADUJET can the pump be installed?** Use 4" plumbing up to 30 ft. For runs longer than 30 ft. use 6" plumbing. The pump can be placed as close to the **BADUJET** as local codes will allow.

How many amps does the pump operate at? Maximum 19.4 amps @ 230 V.

What size breaker do I need? You must use a 40 amp breaker to avoid nuisance tripping.

Is the **BADUJET approved?** Yes. The **BADUJET** swim jet system is listed by MET and complies with UL standard 1563 Swimming Pool Equipment, and ASME standard A112.19.8-2007 Standard for Swim Jet Combination Fittings.

Should this be tied into my filter system? No. The swim jet system and the filter system should not be plumbed together as they each provide very specific functions.

Do I need to install a motor starter? No. The pump has a built-in thermal overload.

Does it matter if the housing is installed higher or lower than the manual states? Yes, the center of the housing must be 10" **BELOW** water level for proper performance of unit.

Can the air regulator be placed elsewhere? Yes. As long as it is not continuously flooded with water.

What if water is discharging out of the air regulator when pump is running? The screws (part #51) that mount the nozzle housing (part #53) are not fully tightened **OR** o-rings (part #62) on the tension cup (part #59) are missing or have rolled out of position during installation.

Can the pump be placed below water level? Yes. However, for best performance we recommend ordering pump for flooded suction (Model 21-80/33 G) instead of self-priming (Model 21-80/33 GS). We recommend installing valves for ease of maintenance.

How far away can the air button function properly? A maximum of 50 ft. Consult factory for distances over 50 ft.

Can I use with automated controls? Yes. It comes with the ability to tie into automated control systems or other switching devices.

13. Difference Between the *Classic* and the super-sport

General:

The **BADUJET Classic** is smaller in diameter (12" instead of 16"). It has only one jet and no regulator knob to adjust the flow of water. The jet nozzle itself is adjustable.

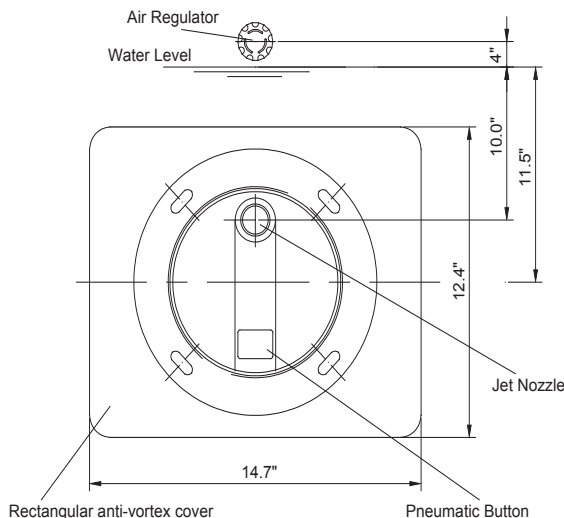

Fig. 2

1. Plumbing the **BADUJET Classic**

The center of the housing should be 11.5" (instead of 10") **BELOW** water level for maximum efficiency. The suction and discharge line may be 3" instead of the 4" required for the large unit.

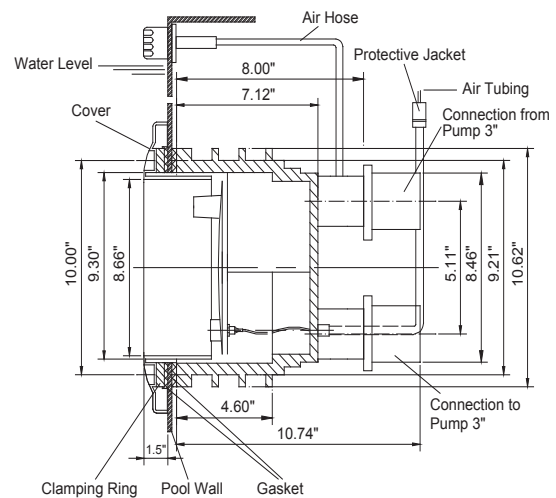
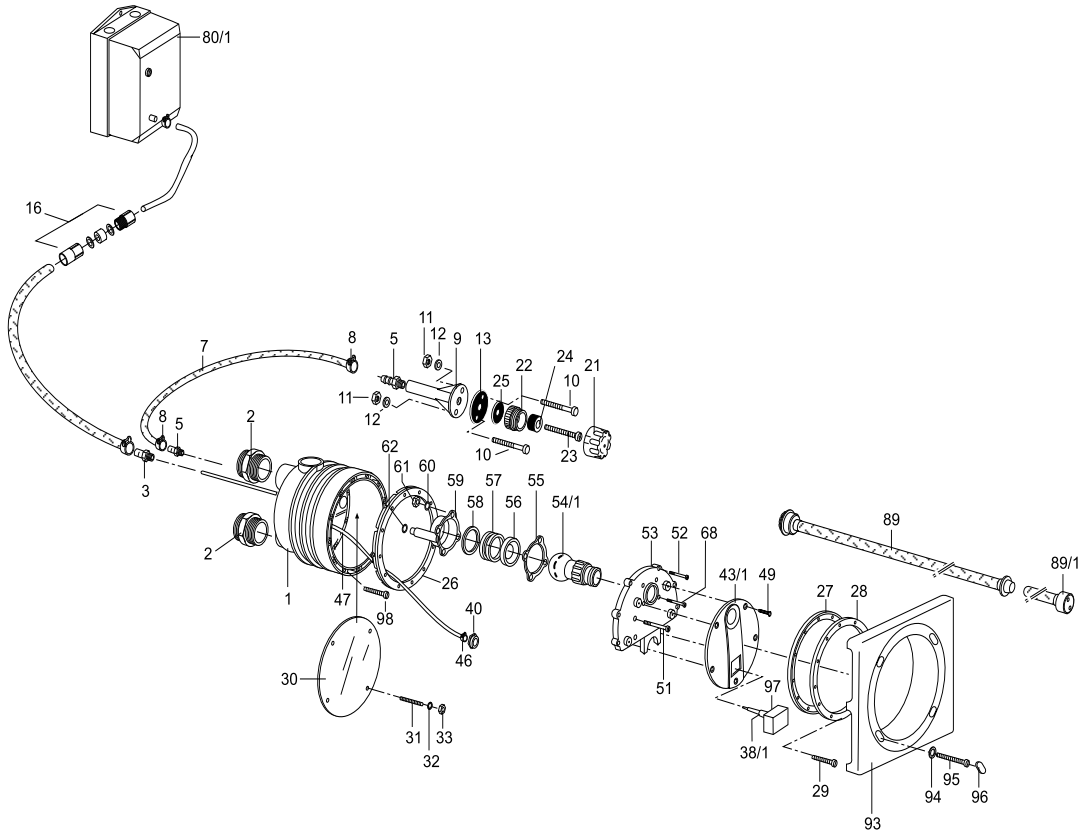

Fig. 3

14. Parts List for the **BADU[®]JET Classic**



Part #	Qty	Description	Part #	Qty	Description
1	1	Jet Housing	43/1	1	Cover - Nozzle
2	2	Adaptor - Male, Housing PVC 2" x 75mm/3"	46	1	Clamp - Hose, Pneumatic Button 8.7mm
3	1	Adaptor - Male, Housing PVC 1/2"	47	10M	Air Tube 4 x 1.5mm (per meter)
5	2	Nipple - Hose, Air Regulator, Plastic 1/4"	49	4	Tapping Screw - Nozzle Cover, Phillips 4.8 x 16 A2
7	1	Hose - Air Regulator 8 x 3mm x 1.4 Meters	51	5	Bolt - Nozzle Housing, Slot/Barrel M6 x 97mm A2
8	2	Clamp - Hose, Air Regulator 14/9 SS	52	6	Bolt - Nozzle Housing, Slot/Barrel M6 x 25mm A2
9	1	Holder - Air Regulator	53	1	Housing - Nozzle
10	2	Bolt - Air Holder, Slot/Pan M6 x 30 SS	54/1	1	Nozzle - Adjustable Flow 40mm
11	2	Nut - Air Holder Bolt M6, A2 SS	55	1	IT Gasket - Tension Cup 103 x 81.5 x 0.6mm
12	2	Washer - Air Holder	56	1	Seat - Nozzle
13	1	Gasket - Air Holder 60 x 11 x 2mm	57	1	Spacer - Nozzle 6.2mm
16	1	Air Tubing Seal Assembly	58	1	Spacer - Nozzle 1.5mm
20	1	Plug - Rubber 7mm	59	1	Tension Cup - Nozzle
21	1	Top Part - Air Regulator	60	4	Washer - Lock, Tension Cup M6 A4
22	1	Bottom Part - Air Regulator	61	4	Nut - Tension Cup M6 A2
23	1	Bolt W/hole - Ar Regulator, Brass M10 x 80	62	1	O-Ring - Tension Cup 11 x 2.5mm
24	1	Ring - Hose, Air Regulator 16 x 30 x 18mm	68	4	Bolt - Tension Cup, Phillips M6 x 25mm A2
25	1	Gasket - Air Regulator 42 x 11 x 2mm	80	1	Control Box BJC-7-GFCI
26	1	Gasket with Knobs - Jet Housing	89	1	Massage Hose 5ft. with Pulsator
27	1	Gasket - Clamping Ring	89/1	1	Massage Hose 15ft. with Pulsator (optional)
28	1	Ring - Clamping	93	1	Cover - Rectangular
29	10	Bolt - Clamping Ring, Slot/Barrel M6 x 25 A2	94	4	Washer - Rectangular Cover M6 A4
30	1	Cover - Gunite	95	4	Bolt - Rectangular Cover, Pan, Phillips M6 x 16mm
31	4	Stud - Gunite Cover, All Thread, Zinc M6 x 80	95/1	4	Bolt - Rectangular Cover, Pan, Phillips M6 x 60mm
32	4	Washer - Stud, Gunite Cover, Zinc M6	96	4	Plug - Rectangular Cover
33	4	Nut - Stud, Gunite Cover M6 A2	97	1	Cover - Button
38/1	1	Pneumatic Button (White)	98	2	Bolt - Jet Housing, Slot/Pan M6 x 30mm SS
40	1	Nut - Pneumatic Button, Plastic			

15. Parts List for the **BADU[®] JET super-sport**

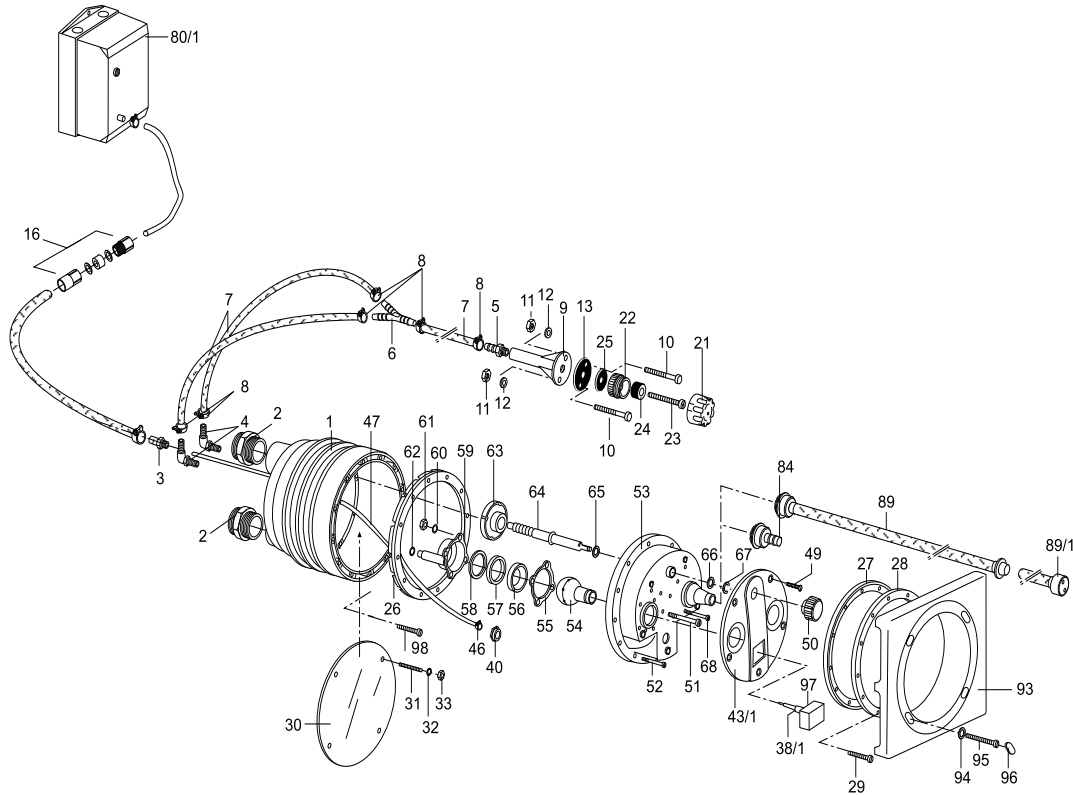

Part #	Qty	Description	Part #	Qty	Description
1	1	Jet Housing	47	10M	Air Tube 4 x 1.5mm (per meter)
2	2	Adaptor - Male, PVC 2-1/2" x 90mm/4"	49	5	Tapping Screw - Nozzle Cover, Phil. 4.8 x 19 A4
2a	2	Coupling - Housing, PVC 110mm/4"	50	1	Volume Control Knob
3	1	Adaptor - Male, Housing, PVC 1/2"	51	10	Bolt - Nozzle Housing, Slot/Barrel M8 x 130 A2
4	2	90° Hose Fitting - Air Regulator, Plastic 1/4"	52	12	Bolt - Nozzle Housing, Phillips/Barrel M8 x 30 A2
5	1	Fitting - Hose, Air Regulator, Plastic 1/4"	53	1	Housing - Nozzle
6	1	Y-Fitting - Air Regulator	54	2	Nozzle - 40mm
7	1	Hose - Air Regulator 8 x 3mm (1.4 meters)	55	2	IT Gasket - Tension Cup 103 x 81.5 x 0.6mm
8	6	Clamp - Hose Regulator 14/9 SS A4	56	2	Seat - Nozzle
9	1	Holder - Air Regulator	57	2	Spacer - Nozzle 6.2 mm
10	2	Bolt - Air Holder, Slot/Pan M6 x 30mm SS	58	2	Spacer - Nozzle 1.0mm
11	2	Nut - Air Holder, M6, A2	59	2	Tension Cup - Nozzle
12	2	Washer - Air Holder, M6, A4	60	8	Washer - Lock, Tension Cup M6 A2
13	1	Gasket - Air Holder 60 x 11 x 2mm	61	8	Nut - Tension Cup M6 A2
16	1	Air Tubing Seal Assembly	62	2	O-Ring - Tension Cup 11 x 2.5mm
21	1	Top Part - Air Regulator	63	1	Volume Control Disc
22	1	Bottom Part - Air Regulator	64	1	Control Spindle
23	1	Bolt W/hole - Ar Regulator, Brass M10 x 80	65	1	Washer - Control Spindle, 23 x 16.2 x 1.5mm
24	1	Ring - Hose, Air Regulator 16 x 30 x 18mm	67	2	Retainer - Shaft, Control Spindle
25	1	Gasket - Air Regulator 42 x 11 x 2mm	68	8	Bolt - Tension Cup, Phillips M6 x 25 A2
26	1	Gasket with Knobs - Jet Housing	80/1	1	Control Box BJC-7-GFCI
27	1	Gasket - Clamping Ring	84	1	Cap - Nozzle, Close off
28	1	Ring - Clamping	89	1	Massage Hose 5ft. with Pulsator
29	12	Bolt - Clamping Ring, Slot/Barrel M8 x 30 A4	89/1	1	Massage Hose 15ft. with Pulsator (optional)
30	1	Cover - Gunite	93	1	Cover - Rectangular
31	4	Stud - Gunite Cover, All Thread, Zinc M8 x 80	94	4	Washer - Rectangular Cover M8 A2
32	4	Washer - Gunite Cover, Zinc M8	95	4	Bolt - Rectangular Cover, Phillips M8 x 20mm
33	4	Nut - Stud, Gunite Cover M8 A2	95/1	4	Bolt - Rectangular Cover, Phillips M8 x 80mm
38/1	1	Pneumatic Button (White)	96	4	Plug - Rectangular Cover
40	1	Nut - Pneumatic Button, Plastic	97	1	Cover - Button
43/1	1	Cover - Nozzle	98	2	Bolt - Jet Housing, Slot/Pan M8 x 30mm A4
46	1	Clamp - Hose, Pneumatic Button 8.7mm			

16. Limited Warranty

The manufacturer supplies a limited warranty to the original consumer purchaser of the **BADUJET** on the following terms and conditions:

1. The **BADUJET** is warranted to be free from defects in material and workmanship for a period of twelve (12) months from the date that the **BADUJET** is originally installed.
2. Notwithstanding any provisions herein to the contrary, the warranties and obligations hereunder shall not in any event extend for more than 2 years beyond the date of shipment of the **BADUJET** from Speck Pumps - Pool Products, Inc. in Jacksonville, Florida.
3. Warranty is void in the following cases: damages which result in whole or in part from: (a) careless or improper installation of the **BADUJET**; (b) improper or negligent use and maintenance of the **BADUJET**; (c) tampering with the **BADUJET** by unauthorized repair personnel; (d) ground movement; (e) substitution of parts and/or components.
4. The manufacturer's sole obligation here under shall be to replace or repair any defective **BADUJET**. The manufacturer reserves the absolute right to determine whether any defective **BADUJET** should be replaced or repaired.
5. Any customer who wishes to make a claim under this Limited Warranty shall notify Speck Pumps, of such claim by telephone or by mail. After the customer has been authorized to return the **BADUJET**, the customer must return the **BADUJET** to Speck Pumps.

Any goods returned to Speck Pumps without prior authorization will be returned to the shipper unopened. Speck Pumps shall not bear any costs or risks incurred in shipping a defective **BADUJET** to Speck Pumps or in shipping a repaired or replaced **BADUJET** to a customer.

6. Speck Pumps will charge customers for all non warranty work which it may perform. Warranty work will not be performed until the customer has accepted the price quoted.

7. Except as specifically set forth above, no other warranties, whether express or implied, including without limitation, the implied warranties of merchantability and fitness for a particular purpose, are made by the manufacturer. In no event will the manufacturer be liable for any loss, including time, money, goodwill, lost profits and consequential damages based on contrast, tort or other legal theory, which may arise hereunder or from the use, operation or modification of the pump, motor or associated parts. The maximum liability of the manufacturer hereunder shall not exceed the amount actually paid by the customer for the pump, motor and associated parts.

8. Some states do not permit limitations on the terms of implied warranties or on the recovery of incidental or consequential damages. Accordingly, the limitations contained in paragraph 7, may not apply to certain customers.

9. This warranty gives customers specific legal rights which may vary from state to state. The **BADUJET** is manufactured under license from **Speck Pumpen**, GERMANY.

Date of Installation: _____

Installed By: _____

Serial Numbers: _____

For Service Call: _____

SAVE THESE INSTRUCTIONS!