

SERVICE MANUAL

Hydraulic Motors type MS(Y)...
and MLHS(Y)...

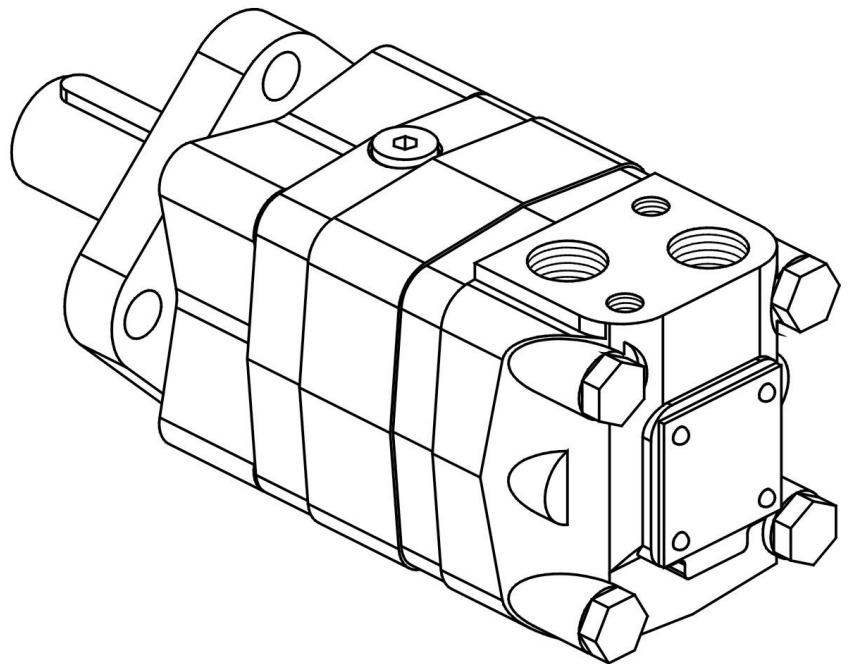

2008

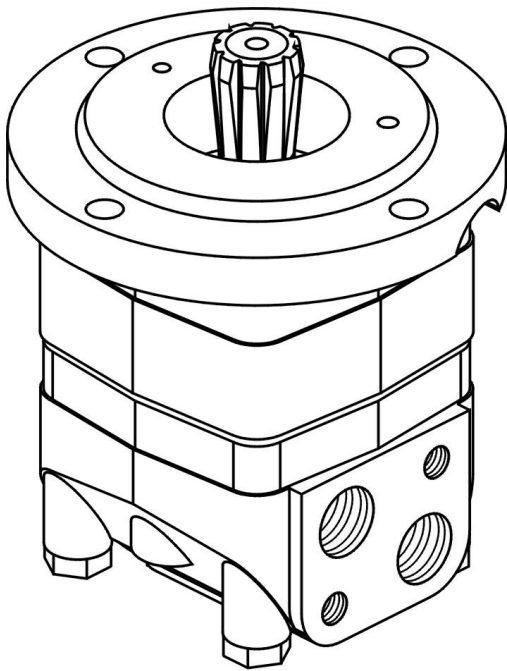
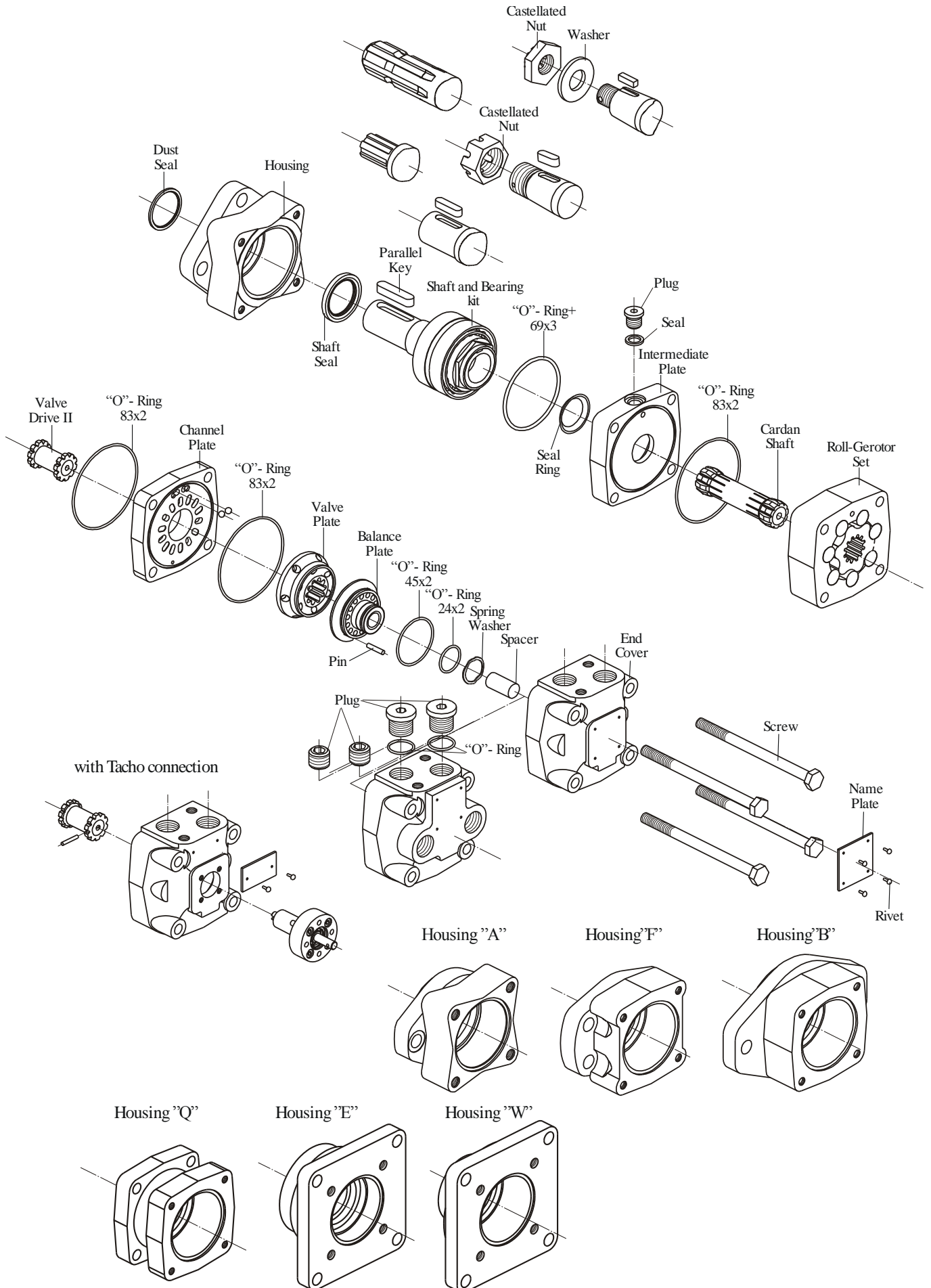

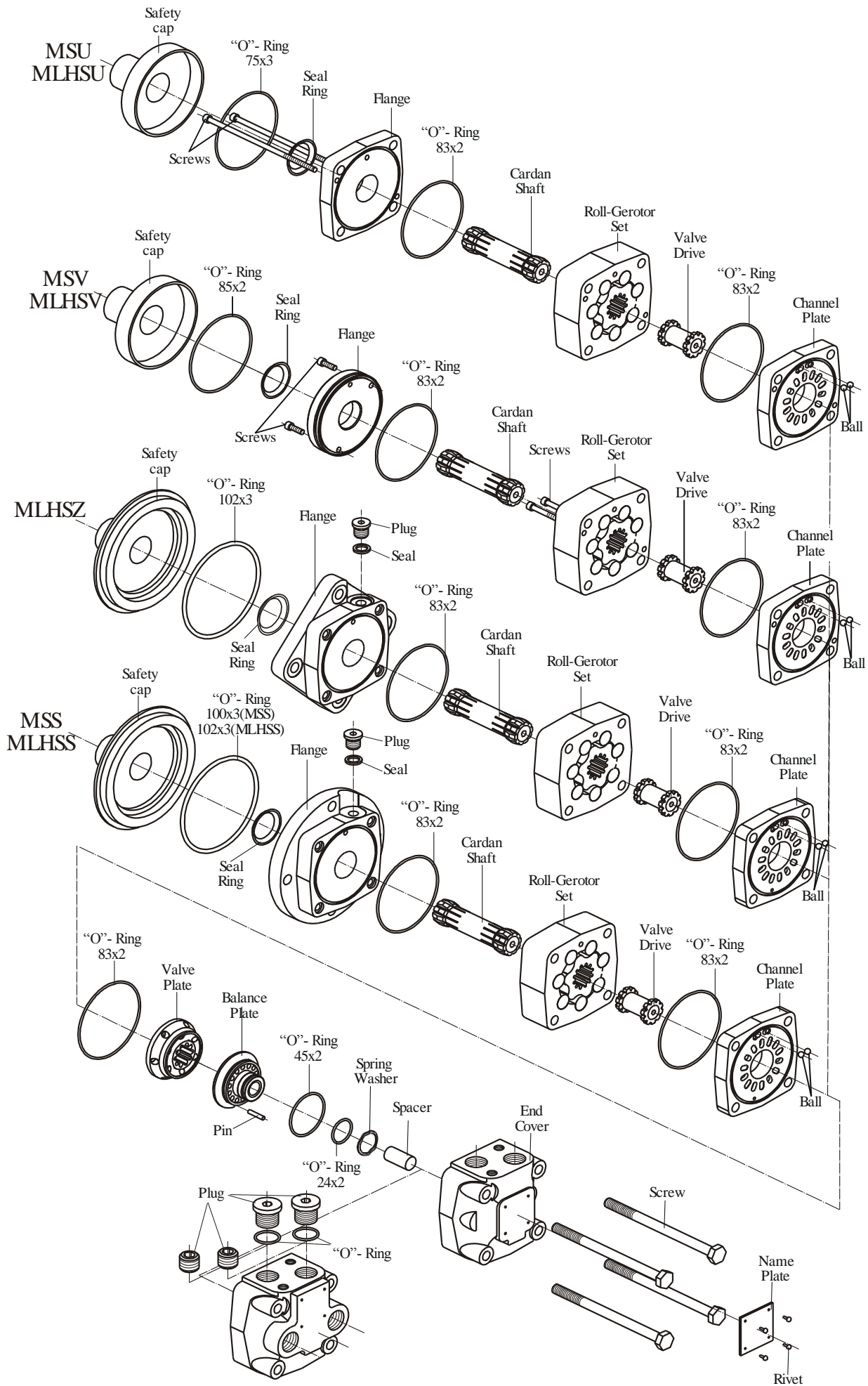

The instructions in this manual concern motor types MS and MLHS.

Cleanliness is extremely important when repairing these motors. Work on clean surface!

Before disassembly, drain the oil from the motor and dry the working bench.

If there is castellated nut, washer or key, they have to be removed from the shaft.

Although not all drawings show the motor in disassembly devise (vice with soft clamping jaws), we recommend the motor to be tightened during disassembly.

1. Unscrew the Drain plug with S6 Allen key and remove the washer (O-ring for MLHS).

2. Place the motor in disassembly devise with output shaft down.

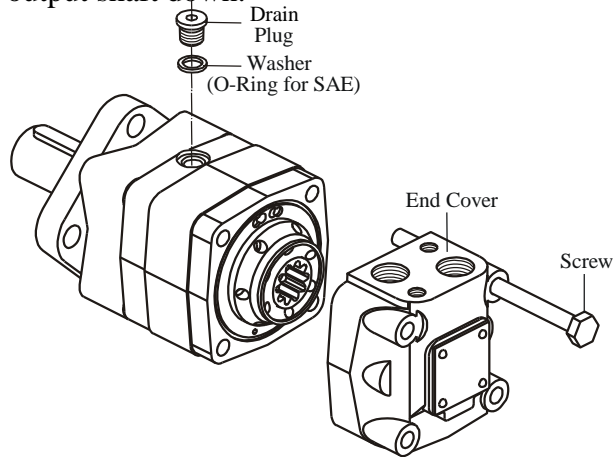

Fig.1

3. Unscrew screws using a S17 torque wrench. (see Figure 1)

4. Remove end cover assembly.

5. Separate Valve Plate from Channel Plate and remove Valve Drive (see Fig.2).

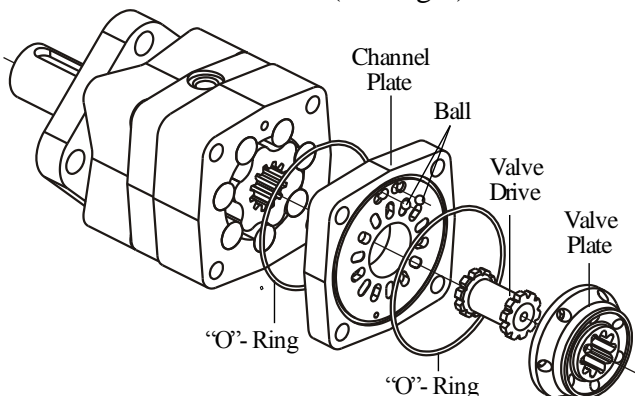

Fig.2

6. Separate Channel Plate from Roll-gerotor set.

7. Remove O-ring 83x2 (2 pcs.), and balls (2 pcs.) from the Channel Plate grooves.

8. Remove the roll-gerotor set carefully to prevent dropping of rollers and rotor from stator. Do not dismount!

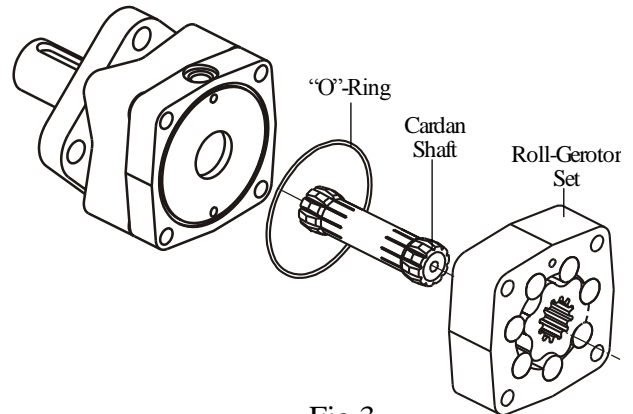

Fig.3

9. Remove cardan shaft from the splines of output shaft (see Fig.3).

10. Separate Intermediate Plate from housing.

11. Remove O-ring 83x2 and Seal Ring from the Intermediate Plate.

12. Fix Housing in a hydraulic press and push output shaft with bearing kit out of housing (see Fig.4).

Note: Replace Output Shaft and bearing kit as a unit. If not necessary do dismount the bearing kit!

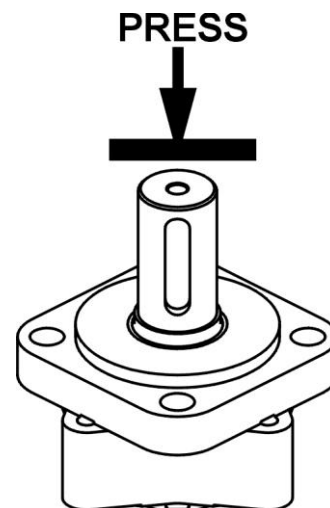

Fig.4

13. Remove dust seal, shaft seal and O-ring carefully from the Housing.

End Cover Disassembly:

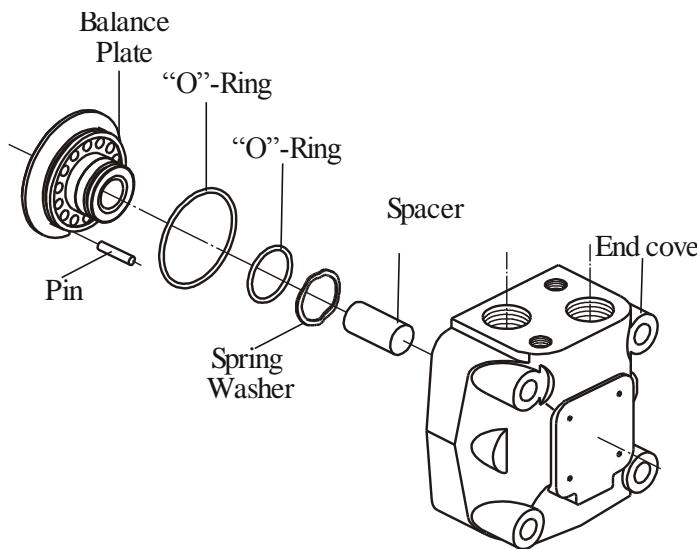

Fig.5

14. Turn the end cover with the hole conversely on a clean soft surface. Knock several times using a plastic hammer on the rear side. Set in order the fallen parts apart (see Fig.5).

15. Remove "O"-Rings (2 paces.) from the grooves of the balance plate.

16. Remove the pin using a vice with soft jaws or pliers knocking on the balance plate and swivelling it round the pin simultaneously.

Seal Kits:

SK 41 5127 9047 for MS...- series 4
 SK 41 5127 8200 for MS...U...- series 4
 SK 41 5129 9400 for MSS... - series 3
 SK 41 5129 1488 for MSV... - series 3
 SK 41 5129 2732 for MSU...
 SK 41 5127 4200 for MSY... - series 3
 SK 41 5127 4000 for MSY...U... - series 3
 SK 41 5129 0400 for MSYS... - series 2
 SK 41 5129 0410 for MSYV... - series 2
 SK 41 5132 5148 for MLHS...D
 SK 41 5132 5153 for MLHS...7...D
 SK 41 5132 0000 for MLHS...U...D
 SK 41 5132 0005 for MLHS...7U...D
 SK 41 5123 9370 for MLHSS...C
 SK 41 5123 9375 for MLHSS...7...C
 SK 41 5123 9434 for MLHSZ...C
 SK 41 5123 9439 for MLHSZ...7...C
 SK 41 5124 6220 for MLHSV...C
 SK 41 5124 6225 for MLHSV...7...C

SK 41 5134 0449 for MLHSY...D
 SK 41 5134 0452 for MLHSY...7...D
 SK 41 5134 0000 for MLHSY...U...D
 SK 41 5134 0005 for MLHSY...7U...D
 SK 41 5123 8820 for MLHSYS...B
 SK 41 5123 8835 for MLHSYS...7...B
 SK 41 5123 8800 for MLHSYV...B
 SK 41 5123 8815 for MLHSYV...7...B

1. CLEANING:

Wash all parts (except seals) in a weak solvent on carbon base and then degreased.

2. MEASURING AND REPLACEMENT:

Measure all parts and compare their actual dimensions with the nominal ones given in the technical documentation. Replace any parts with scratches or burrs that could cause leakage or damage with new ones. Use new seals and washers when reassembling the motor.

3. LUBRICATION:

Lubricate all frictioning parts, which should be reassembled with light film of petroleum jelly.

Place bearing housing on clean soft surface. Lubricate shaft seal and dust seal with light film of clean petroleum jelly.

1. Place shaft seal in the bearing housing and firmly push with Seal driver (see Fig.6).

2. Install dust seal in the bearing housing. Carefully press dust seal into place.

Lips of shaft seal and dust seal must face outward.

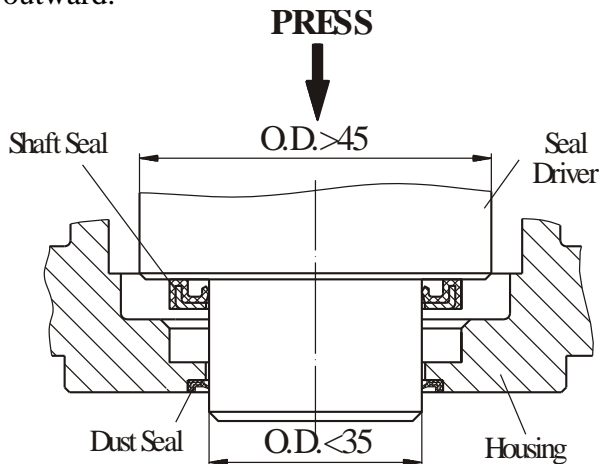

Fig.6

Important: After installing in bearing housing check seal condition. If damaged, cut or improperly installed, replace with new ones.

3. Place the housing in reassembly device (vice). Lubricate all inner surfaces.

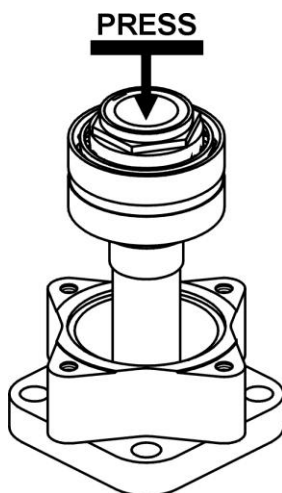

Fig.7

4. Use a press to install output shaft with bearing kit into housing (see Fig.7). Be careful not to invert or damage the seals.

Rotate the shaft by hand. Max. moment of rotation of the shaft with assembled bearing is 0,25 daNm.

Alignment studs can be very helpful in reassembly of the motor. Install two studs M10x200 diagonally in the housing.

5. Lubricate and install the O-ring 69x3 in housing seal grooves.

6. Install the seal ring in the Intermediate plate and assemble it through the studs. Lubricate O-ring 83x2 and place it in seal groove of Intermediate Plate.

7. Install the cardan shaft into splines of the output shaft.

Timing Procedure

8. Orientate the Roll-Gerotor set acc.to Fig.8 and assemble the rotor splines into the cardan shaft splines. (If necessary, turn the shaft to one or another direction for keeping symmetry of rotor towards stator.)

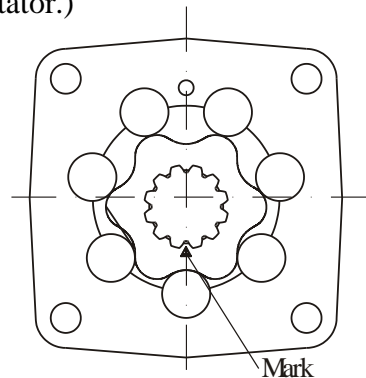

Fig.8

9. Install the valve drive into the rotor spline sector.

10. Mark the rotor at the point where the tip of a spline tooth is opposite to the bottom of a tooth in the external rotor teeth as shown on Fig.8 and 9.

11. Mark the bottom of a spline on the valve drive. Line up mark on rotor and valve drive.

12. Lubricate O-rings 83x2 (2 pcs.) and place them in seal grooves of both sides of Channel Plate.

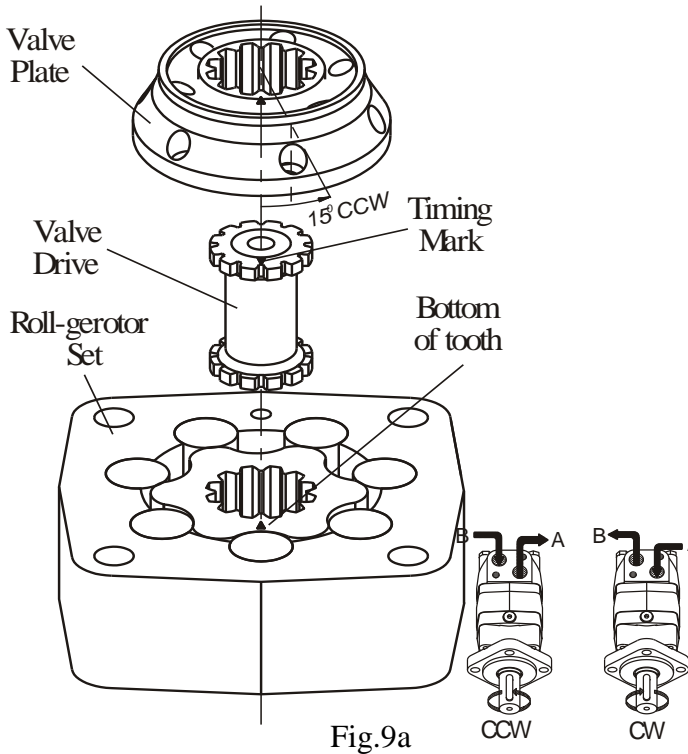

Fig.9a

13. Lubricate the roll-gerotor set surface and place on it the channel plate.

14. Lubricate and install 2 psc. Balls in channel plate ball grooves (see Fig.2).

15. Align mark on valve drive with a hole in the outer rim of the Valve Plate. Turn Valve Plate clockwise (as shown on Fig.9a) until splines in the two parts engage / rotation about 15°.

Reverse Rotation:

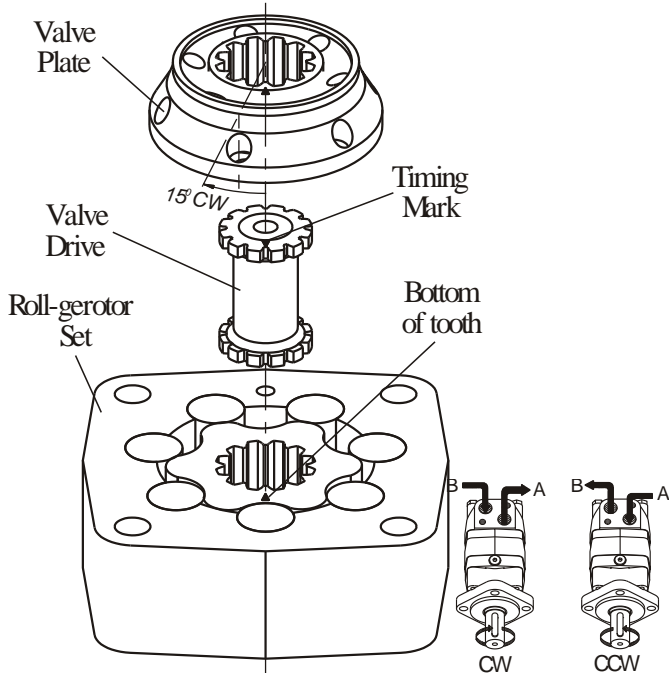

Fig.9b

Reverse rotation is obtained by rotation of the Valve Plate counter clockwise (as shown on Fig.9b) until splines in the two parts engage.

Reassembly of End Cover:

16. Mount the lubricated “O”-Rings (2 pcs.) in the relevant grooves of the balance plate (see Fig.5).

17. Stave the preliminarily lubricated pin into the balance plate hole (to the thin end).

18. Place the cover with the front for nameplate downwards. Lubricate lightly all internal cap surfaces to protect seals. Put the spring washer into hole with passing diameter.

19. Place the balance plate (set) inside the end cover with the pin orientated to fall in with the hole of its bottom. Use a plastic hammer.

Lubricate spacer and install in the balance plate hole.

Parts are correctly assembled when at pressing the front surface of balance plate by thumbs downwards, the balance plate jumps up itself as a result of spring force.

20. Mount the end cover (set) carefully over both studs. Make sure that the port face of end cover coincides with the orientated drain port.

21. Install the screws in End cover. Tighten screws with 6÷7 daNm torque using an S=17 mm torque wrench.

22. Install washer (O-ring for SAE) on drain plug. Tighten plug with Allen key S6 with torque 2,0 ÷ 2,5 daNm.

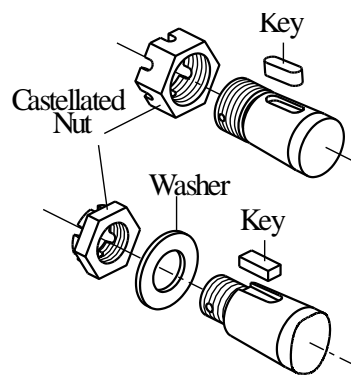

Fig.10

23. Install key in shaft key groove. For cone shafts install washer and screw castellated nut (see Fig.10).

Disassembly and reassembly of short (without bearings) motors type “S”, “V”, “Z” and “U”:

These motors are the same as the standard motors without bearing unit /Output shaft and Housing/. Intermediate plate is replaced with Flange. Follow the same disassembly and reassembly procedures as for the rear section of standard motor.

For MSS (MLHSS, Z) only: Fit shaft cap for MSS motors to flange. Place the flange in the fixture with the cap downwards. Screw 2 assembly studs M12 in opposite flange holes by hand. Install in flange cardan shaft. Shaft cup will prevent dropping out of cardan shaft. Follow the reassembly procedures from 8 to 21. Mount the rear section carefully over assembly studs. Turn motors with the flange upwards and remove the shaft cap. Lubricate cone seal ring and place it in the flange. Lubricate O-ring and install into flange seal groove.

For MSV (MLHSV) only: Fit shaft cap for MSV motors to Roll-gerotor set. Screw 2 assembly studs M12 in opposite Roll-gerotor set holes by hand. Install cardan shaft in Roll-gerotor set. Shaft cup will prevent dropping out of cardan shaft. Follow the reassembly procedures from 8 to 20. Mount the rear section carefully over both studs. Replace studs with screws. Turn the motor on 180° and remove shaft cap. Mount roll-gerotor set to end cover with two screws M5 using S5 (4) Allen head spanner. Tighten with 0,5÷0,7 daNm torque. Install flange to roll-gerotor set and tighten with two screws M5x16 with 0,5÷0,7 daNm torque. Lubricate cone seal ring and place it in front cup. Lubricate O-ring and install into front cap seal groove.