

"Apollo"® Valves

MAINTENANCE MANUAL

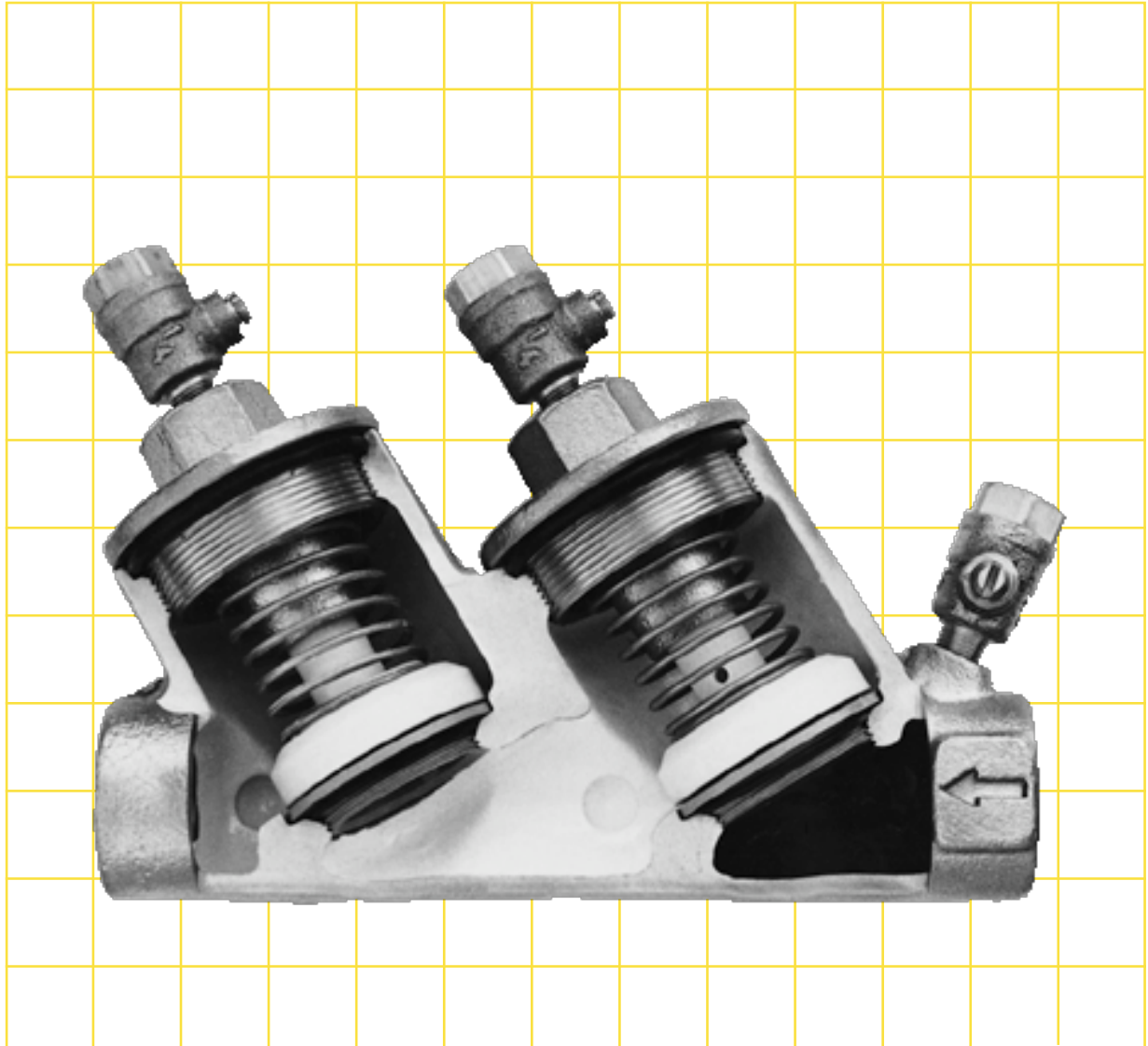

COVERING MODELS:

- 40-300 Series (1/2")**
- 4S-100 Series (1/2" ONLY)**
- 40-100 Series (3/4" - 2")**
- 40-100-T Series (3/4" - 2")**
- 40-100 Series (2-1/2" - 10")**
- 40-600 Series (3" - 10")**

TABLE OF CONTENTS

Double Check Valve Backflow Preventer 1/2" - 10" & Double Check Detector Assembly 3" - 10"

Section	Page
Description and Operation2, 3
Installation2
Trouble Shooting Guide4
Maintenance Instructions 1/2" (40-103)4
Maintenance Instructions 1/2" (4S-103)5
Maintenance Instructions 3/4" - 2"5
Maintenance Instructions 2-1/2" - 10"6
Testing Procedure 1/2" - 10"6 - 11
Parts Listing 40-300, 1/2"12
Parts Listing 4S-103, 1/2"13
Parts Listing 40-100, 3/4" - 2"14 - 17
Parts Listing 2-1/2" - 10"18 - 21
Parts Listing 3" - 10" DCDA22 - 25
Warranty26

Double Check Backflow Preventer

I DESCRIPTION AND OPERATION

The Double Check Valve (DCV) device consists of two independently acting, spring loaded check valves. Two resilient seated shut-off valves and four test cocks complete the assembly.

Each check is designed to maintain a minimum of 1 psi across the valve during normal operation. If at any time the pressure downstream of the device increases above the supply pressure, both check valves will close to prevent any backflow from occurring.

The various styles and sizes of Double Check Valves are illustrated in figures 1, 2, 3, 4 and 5.

II INSTALLATION

- The DCV must be installed in an accessible location to facilitate periodic field testing and maintenance.
- Flush all upstream piping thoroughly to remove foreign matter prior to installing the device.
- The device should be installed horizontally for ease of maintenance and testing. A clearance between the lower most portion of the device and flood grade or floor should be provided for ease of maintenance.
- When shut-off valves are provided separately, they should be installed with a test cock on the upstream side of the inlet shut-off valve.
- After installing the assembly and with downstream or #2 shut-off valve closed, pressurize the device and bleed air through test cock #4. Then open #2 shut-off valve.

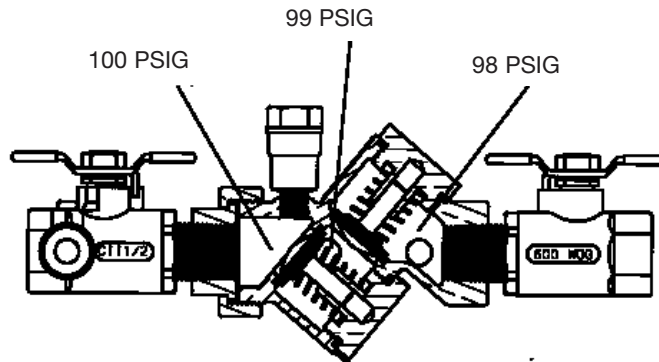

FIGURE 1

1/2" - 40-103

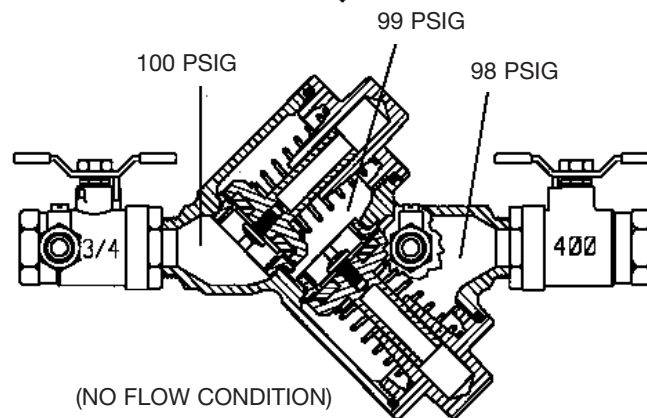

FIGURE 2

(40 - 10X - A2)
Y - Pattern

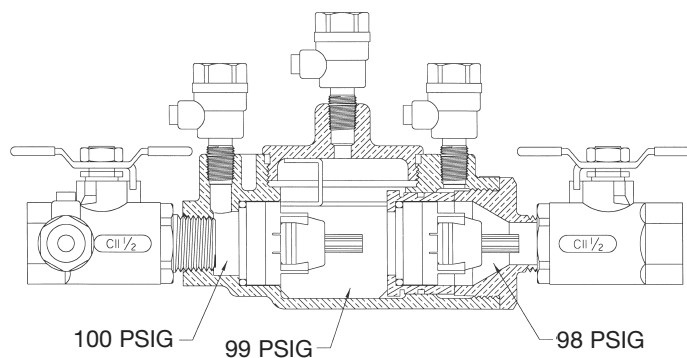

FIGURE 3

1/2" - 4S-103
(NO FLOW CONDITION)

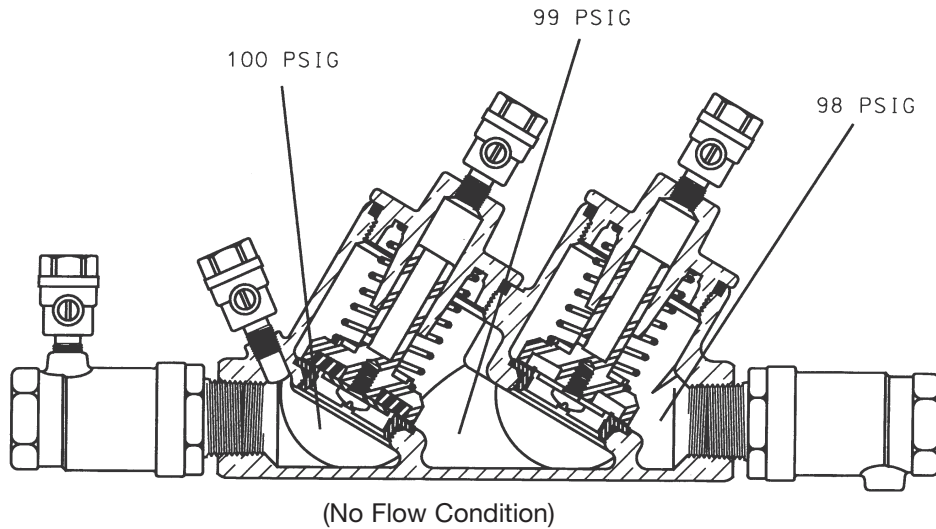

FIGURE 4
40 - 10X - T2
Top Entry

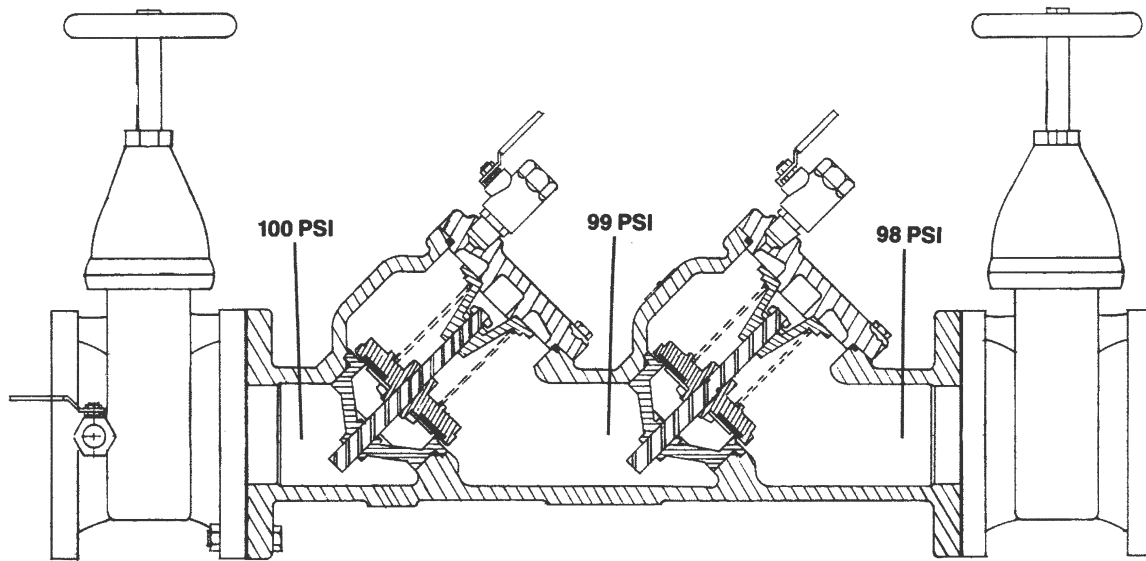

FIGURE 5

Double Check Detector Assembly (DCDA)

The DCDA device consists of a mainline DCV and a by-pass assembly consisting of an approved DCV assembly and water meter. Each device is equipped with test cocks for periodic field testing and is normally supplied with inlet and outlet shut-off valves. For information on operation, installation, trouble shooting & testing refer to Installation Instruction Booklet I476700 furnished with each DCDA unit. For maintenance instructions see pages 4 - 6. For parts list see pages 21 - 24.

III TROUBLE SHOOTING GUIDE

SYMPTOM	CAUSE	CORRECTIVE ACTION
<p>1. Check valve fails to hold 1 psid.</p>	<p>a. Shut-off valve not closed completely.</p> <p>b. Check valve fouled with debris.</p> <p>c. Check poppet stem not moving freely in guide.</p>	<p>a. Close #2 shut-off valve or inspect for possible through leakage.</p> <p>b. Inspect and clean seat disc and seat.</p> <p>c. Inspect for debris or deposit on poppet stem or guide.</p>

IV MAINTENANCE INSTRUCTIONS 1/2" (40-103)

A. Disassembly – Check Valves

1. Close #2 shut off valve, then close #1 shut-off valve.
2. Bleed pressure from the assembly by opening #2, #3, and #4 test cock.

CAUTION:

Caps are spring loaded and should be removed carefully to avoid personal injury.

3. Unscrew cap using hex head provided.
4. Remove spring and poppet assembly from the body.
5. Remove the seat disc from the poppet.

B. Inspection

1. All parts should be carefully inspected for any damage or excessive wear and thoroughly rinsed in clean water prior to reassembly. Replace worn parts as necessary.

C. Assembly – Check Valve Poppet

1. Install new disc in poppet.

NOTE:

Due to symmetry of the disc, the old disc may be turned over to obtain an effective seal.

D. Assembly – Check Valve

1. Install the poppet assembly into the body.
2. Install the spring onto the poppet.
3. Apply a thin coat of FDA approved lubricant on cap O-Ring.
4. Guide cap over spring and poppet stem and tighten cap.

V MAINTENANCE INSTRUCTIONS 1/2" (4S-103)

Disassembly

1. Close inlet and outlet shut-off valves
2. Bleed pressure from the assembly by opening #2, #3, and #4 test cock.
3. Unscrew and remove bronze cap.
4. Remove stainless steel spacer using lifting tab.
5. Remove first check module by pulling outward with fingers (a small screwdriver may aid removal). Be sure test cock #2 is open so as to prevent hydraulic lock. Generally, the first check o-ring will remain in the bore.
6. Remove second check assembly by sliding the assembly out of its bore (a small screwdriver placed in the groove provided will aid removal). Be sure test cock #4 is open as to prevent hydraulic lock.

Inspection

1. All parts should be carefully inspected for any damage or excessive wear and thoroughly rinsed in clean water prior to reassembly.
2. Replace all worn parts as necessary.

NOTE:

Check valve modules are not user serviceable. In the event of check failure, replacement modules are sold individually.

Assembly

1. Replace check modules, second check first then first check. Make sure first check o-ring is installed. (Tip: push o-ring to the bottom of the bore before installing check module.) Press check module into bore. A thin coat of FDA approved lubricant on o-ring will aid insertion.
2. Replace stainless steel spacer.
3. Apply a thin coat of FDA approved lubricant on cap o-ring. Replace Cap.

VI MAINTENANCE INSTRUCTIONS 3/4" - 2"

A. Disassembly — Check Valves

1. Close #2 shut off valve, then close #1 shut-off valve.
2. Bleed pressure from the assembly by opening #2, #3 and #4 test cock.

CAUTION:

Caps are spring loaded and should be removed carefully to avoid personal injury.

3. Unscrew cap using hex head provided.
4. Remove spring and poppet assembly from the body.

B. Disassembly — Check Valve Poppet

CAUTION:

Do not use pliers or other tools which may damage or scratch the plastic stem.

1. Holding the poppet assembly in one hand, remove screw and retaining washer.
2. Remove the seat disc.
3. All parts should be carefully inspected for any damage or excessive wear and thoroughly rinsed in clean water prior to reassembly. Replace worn parts as necessary.

C. Assembly — Check Valve Poppet

1. Install new disc in poppet and secure with washer and screw.

D. Assembly — Check Valve

2. Place and center the poppet assembly in the body.
3. Install the spring onto the poppet.
4. Apply a thin coat of FDA approved lubricant on cap O-Ring.
5. Guide cap over spring and poppet stem and tighten cap.

VII MAINTENANCE INSTRUCTIONS 2-1/2" - 10"

A. Disassembly — Check Valves

1. Close #2 shut-off valve, then close #1 shut-off valve.
2. Bleed pressure from the assembly by opening #2, #3, and #4 test cock.
3. Remove cover bolts and cover.

NOTE:

The spring load on the cover will be removed when the cover bolts are backed off approximately 3/8".

4. Remove the complete check assembly straight out of the valve body being careful not to damage the seat ring.
5. The check valve seat is threaded into the body and may be removed at this time if necessary (The seat is bolted into the body on the 10" unit).

6. To remove the seat disc, remove the retaining plate nut (On the 8" & 10" units remove the retaining plate bolts) and retaining plate, remove disc.

WARNING:

The check valve spring is held in compression by the stem nut on top. This nut should not be removed unless the spring requires replacement.

B. Assembly — Check Valves

1. Install seat disc in holder and secure with retaining plate and retaining nut or bolts as applicable.

NOTE:

Due to the symmetry of the disc, the old disc may be turned over to obtain an effective seal.

2. Install the check valve assembly into the body.
3. Install the check valve cover and tighten bolts evenly.

VIII TESTING PROCEDURES

NOTE:

It is important that the DCV device be tested periodically in compliance with local codes, but at least once a year or more, as service conditions warrant.

METHOD 1 (Duplex Gauge)

NOTE:

Test set-up is illustrated in Figure 5 for 1/2" through 2" and Figure 6 for 2-1/2 through 10".

EQUIPMENT REQUIRED:

Conbraco double check backflow preventer test kit.

NOTE:

All connections must be free from leaks in order to achieve accurate readings during testing.

TEST NO. 1:

Purpose:

To test check valve #1 for tightness against reverse flow.

Requirement:

The valve shall permit no through leakage in a direction reverse normal flow under all conditions of a pressure differential.

PROCEDURE:

1. Bleed water through all four test cocks to flush any foreign material.
2. Connect the "high" side hose to test cock #2. Connect the "low" side hose to test cock #3.
3. Open test cocks #2 and #3. Bleed both hoses, making sure to bleed the low side last.
4. Close #2 shut-off valve, then close #1 shut-off valve.

5. Slowly open by-pass valve #1 and lower the pressure at test cock #2 approximately 2 psi below the pressure at test cock #3. **Note:** Due to check valve disc compression, both "high" and "low" side gauges may drop at the same rate approximately 10-15 psi or more. After the check valve disc compresses fully the required "high" side pressure of 2 psi below the "low" side should be obtainable. If this pressure differential can be maintained then check valve #1 is reported as "tight" or "okay". Proceed to test no. 2. However, if this pressure differential cannot be maintained proceed to step no. 6.
6. Open #1 shut-off valve to repressurize the device.
7. Loosely attach the vent hose to test cock #1. Bleed all air from the gauge and vent hose by opening by-pass valve #2. Close by-pass valve #2, tighten vent hose. Open test cock #1.
8. Close #1 shut-off valve.
9. Loosen the "low" side hose at test cock #3 and lower the pressure in the assembly approximately 10 psi. Retighten hose.
10. Simultaneously open by-pass valves #1 and #2 very slowly. If the check valve is holding tight the "high" side gauge will begin to drop while the "low" side gauge will rise. Close both by-pass valves. If a small (no more than 5 psi) pressure differential is created and held, then the check valve is reported as "tight" or "okay." If a pressure differential cannot be maintained the check valve is reported as leaking.

TEST NO. 2:

Purpose:

To test check valve #2 for tightness against reverse flow.

Requirement:

The valve shall permit no through leakage in a direction reverse to normal flow under all conditions of a pressure differential.

PROCEDURE:

Same as test #1 except the "high" side hose is connected to test cock #3 and the "low" side connected to test cock #4.

RESTORE OPERATION:

Close all test cocks. Remove testing equipment. Open shut-off valves #1 and #2.

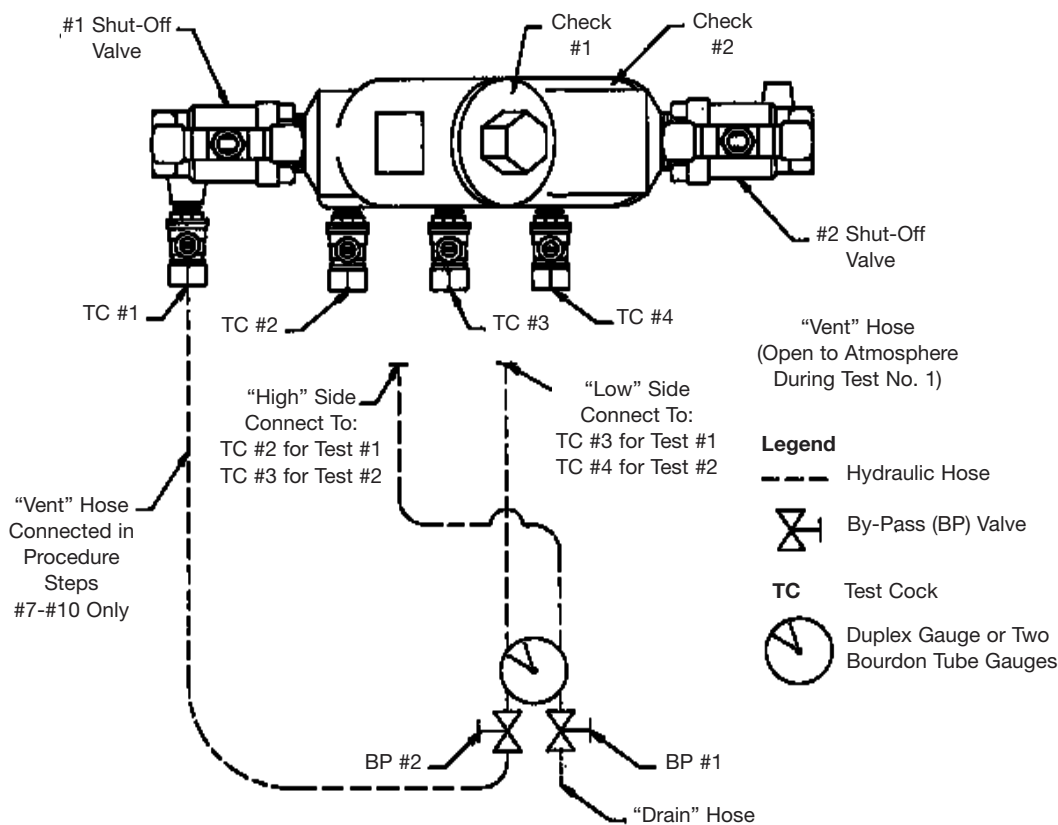
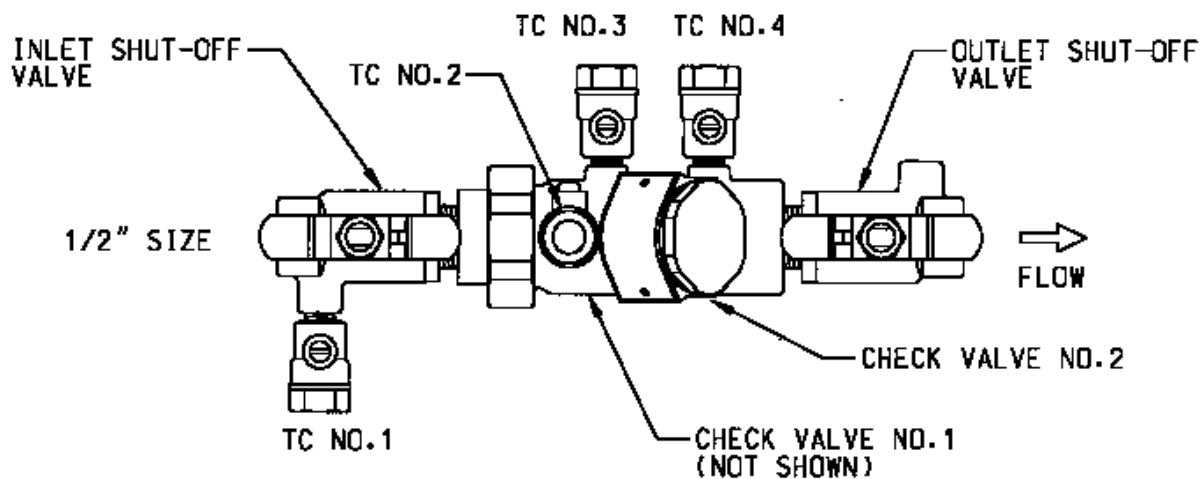

FIGURE 5

DOUBLE CHECK VALVE

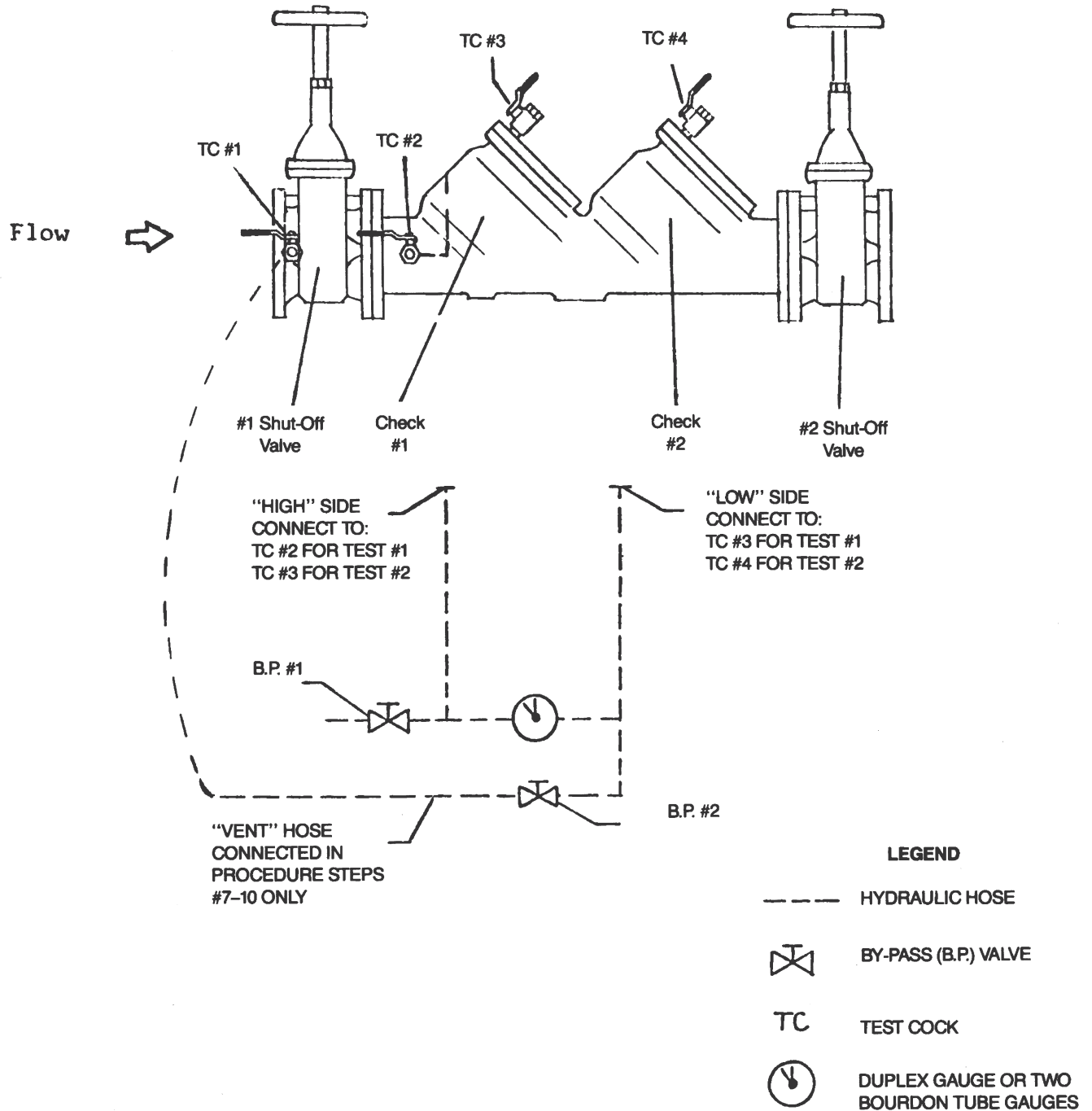

FIGURE 6

METHOD 2

NOTE:

Test set-up is illustrated in Figure 7 for 1/2" through 2" and Figure 8 for 2-1/2 through 10".

EQUIPMENT REQUIRED:

Differential pressure gauge type test kit such as Conbraco Model No. 40-200-TKU or 40-200-TK5U.

NOTE:

For all testing, the gauge and open ends of hoses not being used must be held at the same level as the assembly being tested.

TEST NO. 1:

Purpose:

To determine the static pressure drop across check valve No. 1.

Requirement:

The static Pressure drop across check valve No. 1 shall be at least 1 psid.

PROCEDURE:

1. To eliminate foreign material, flush all four test cocks, one at a time.
2. Open test valves No. 1 and No. 2 on the gauge and close test valve No. 3. Attach "high" side hose to test cock No. 2.
3. Bleed all air from hose and gauge by slowly opening test cock No.2. Then slowly close test valve No. 2.
4. Close the outlet shut-off valve. Then close the inlet shut-off valve.
5. Slowly open test cock No. 3. After the gauge reading stabilizes and water stops running out of test cock No. 3, the static pressure drop across the check valve indicated by the gauge and is recorded as such.

NOTE: If water continues to discharge from test cock No. 3 then a leaky shut-off valve is evident and should be repaired or bypassed before testing continues. If the water recedes from the test cock opening then move the gauge to a point level with the centerline of the check seat area and record the gauge reading as the static pressure differential across check No. 1.

TEST NO. 2:

Purpose:

To determine the static pressure drop across check valve No. 2.

Requirement:

The static pressure drop across check valve No. 2 shall be at least 1 psid.

PROCEDURE:

1. Open test valves No. 1 and No. 2 on the gauge and close test valve No. 3. Attach "high" side hose to test cock No. 3.
2. Bleed all air from hose and gauge by slowly opening test cock No. 3. Then slowly close test valve No. 2.
3. Close the outlet shut-off valve. Then close the inlet shut-off valve.
4. Slowly open test cock No. 4. After the gauge reading stabilizes and water stops running out of test cock No. 4, the static pressure drop across the check valve is indicated by the gauge and is recorded as such.

NOTE: If water continues to discharge from test cock No. 4 then a leaky shut-off valve is evident and should be repaired or bypassed before testing continues. If the water recedes from the test cock opening then move the gauge to a point level with the centerline of the check seat area and record the gauge reading as the static pressure differential across check No. 2.

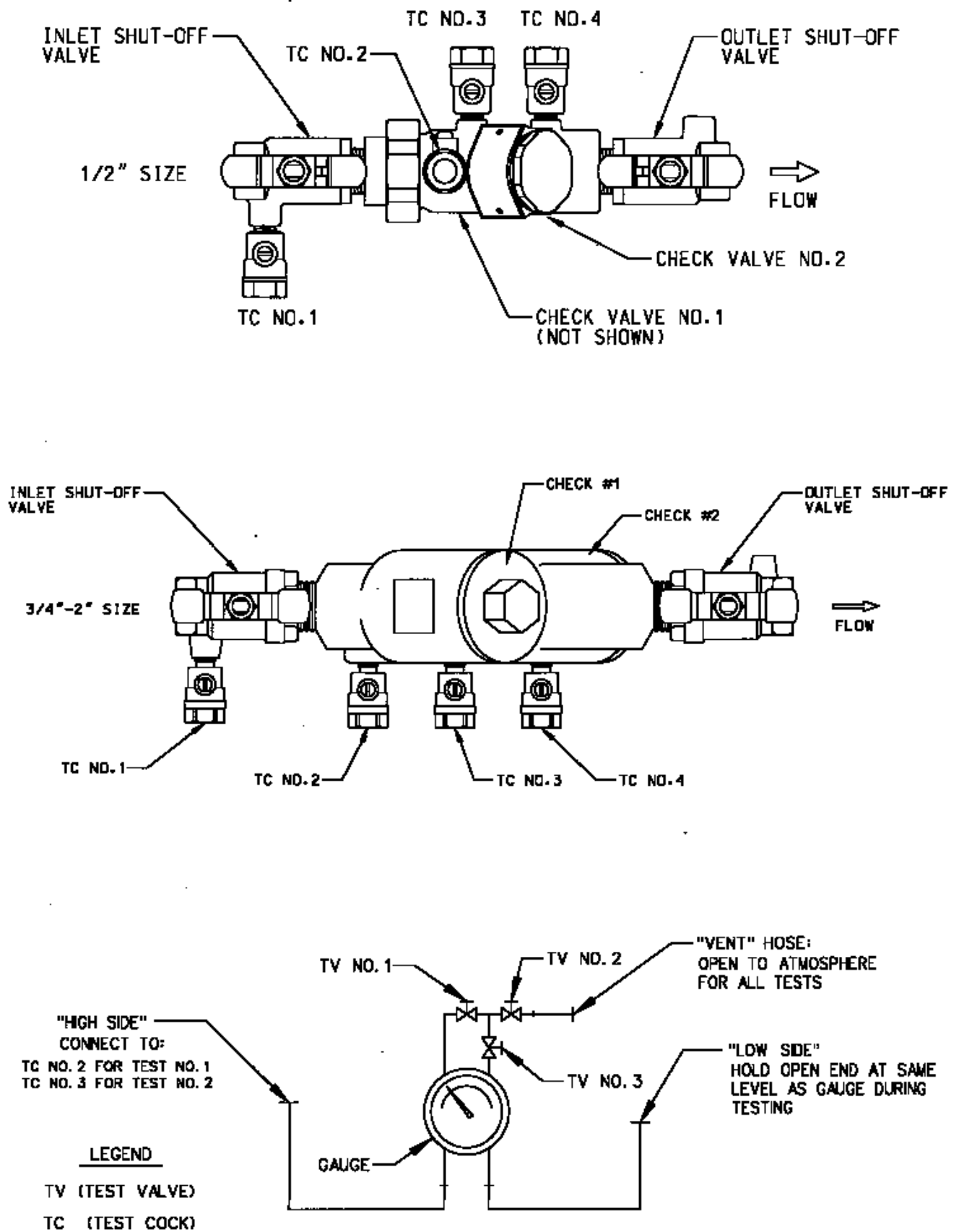

FIGURE 7

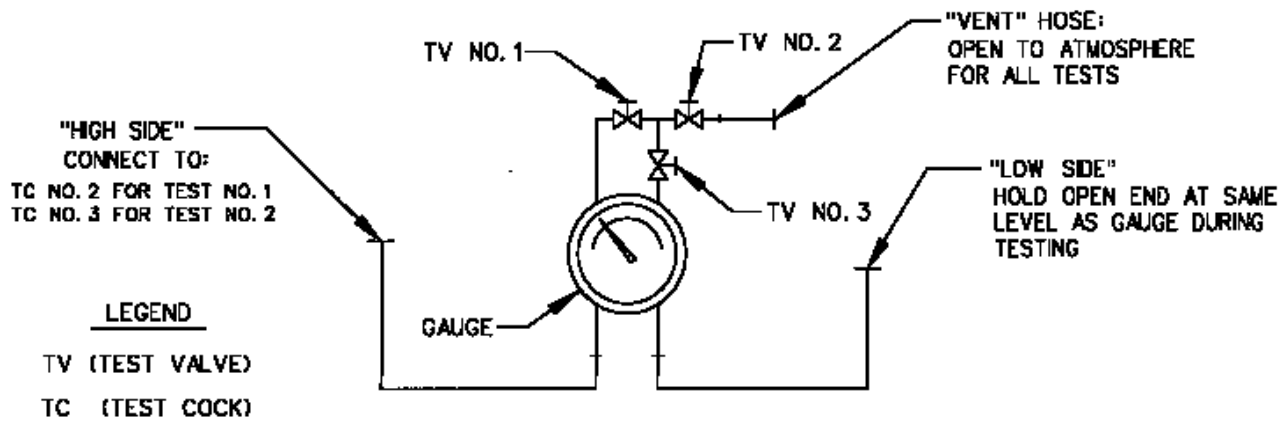
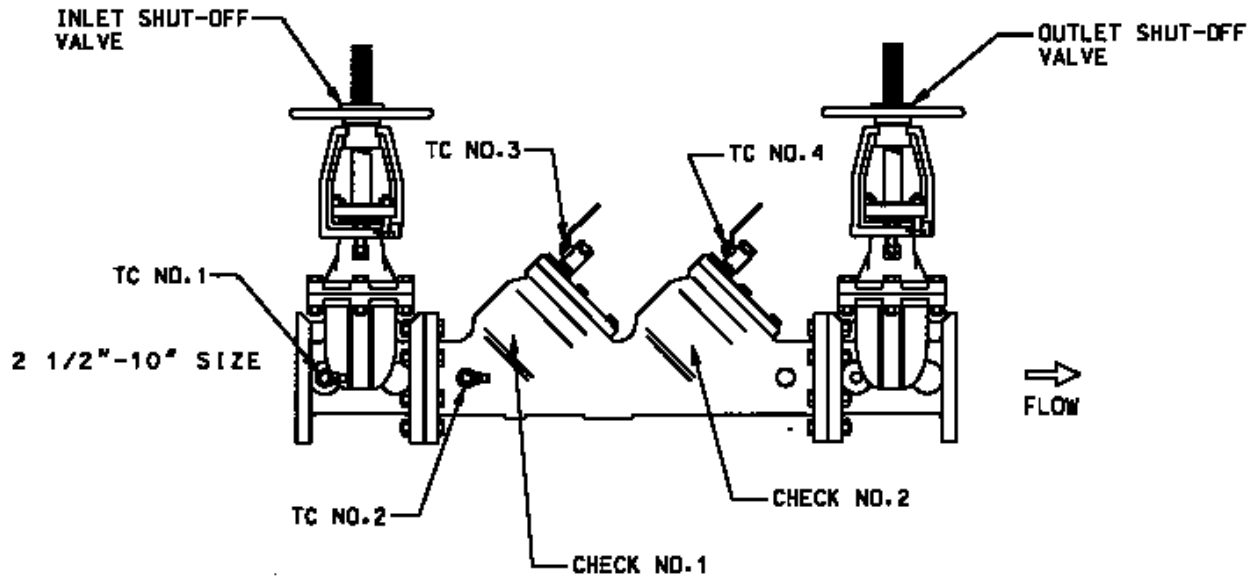
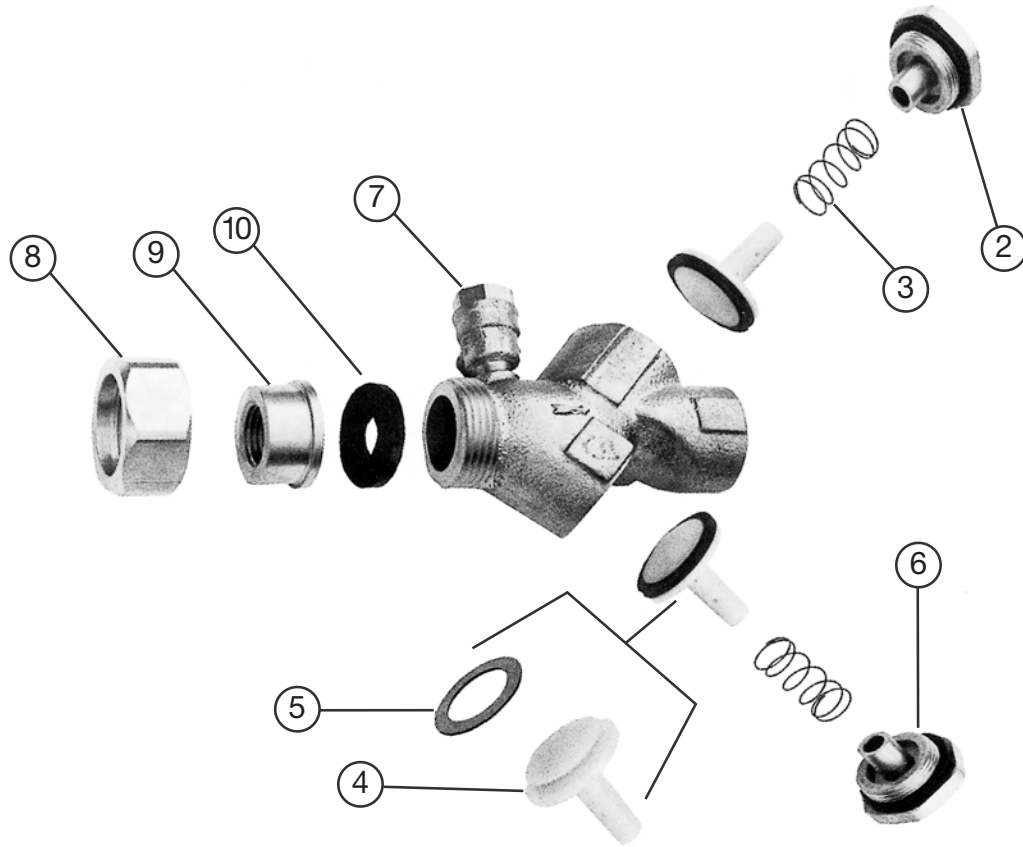

FIGURE 8

Parts Listing 1/2" (Bronze)



**40-300 Series
Double Check Backflow Preventer**

ITEM NO.	DESCRIPTION	QUANTITY	PART NO.
			1/2"
1	Body	1	Consult Factory
2	Cap	2	F-3009-06
3	Spring	2	A-1750-00
4	Poppet	2	K-3404-00
5	Seat Disc	2	D-2600-00
6	Cap O-Ring	2	D-2501-00
7	Test Cock	3	78-257-01
8	Union Nut	1	C-1778-06
9	Tail Piece	1	L-5226-06
10	Seal	1	D-2607-00

Repair Kits

Major Repair Kit

(3 (2), 6 (2), part no. W-6759-06 (2)), n/s packet lube

40-300-02

Rubber Repair Kit

(5 (2), 6 (2)), n/s packet lube

40-300-01

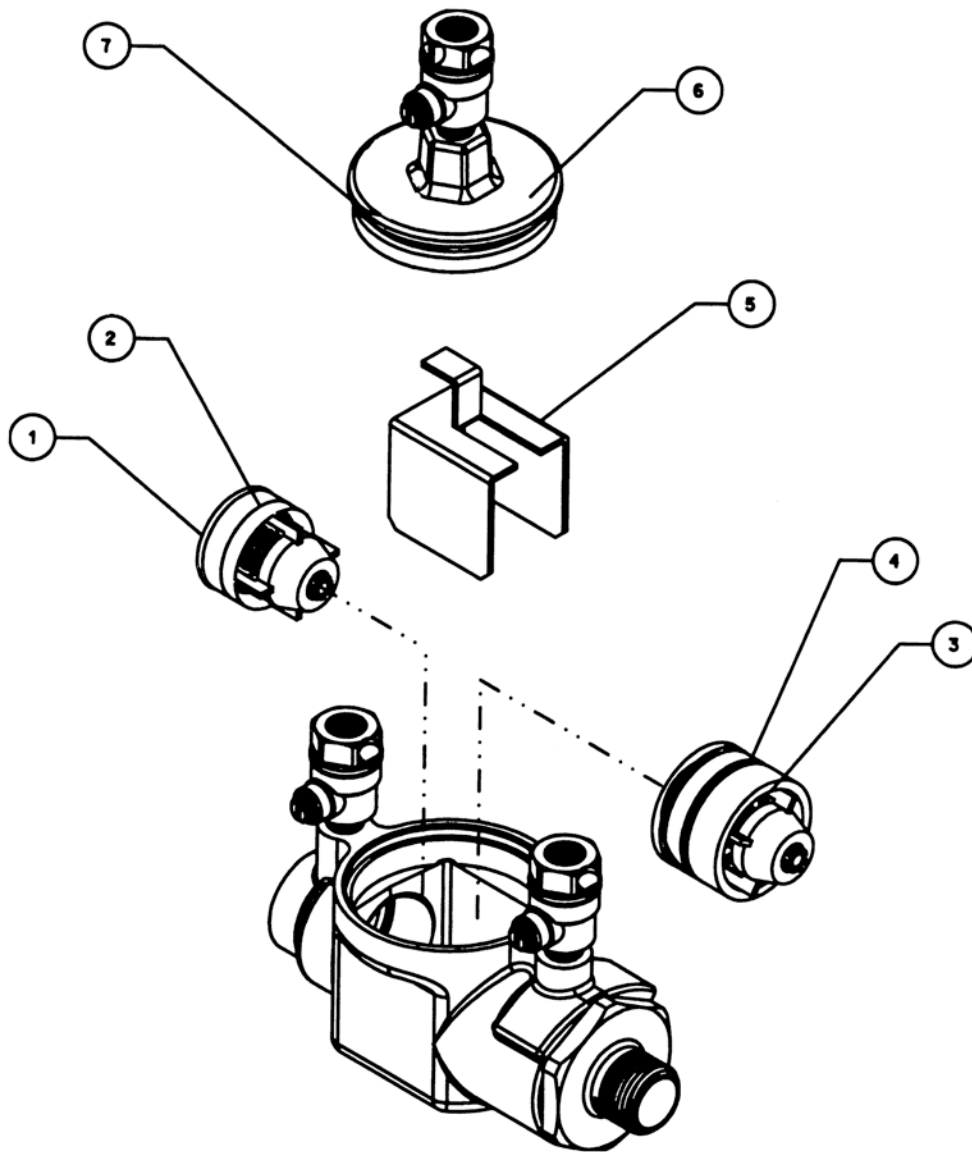

1/2" 4S-103 Double Check Valve

ITEM NO.	PARTS LIST.	DESCRIPTION	QUANTITY
1	D-3885-00	Check Module O-Ring	1
2	F-3228-00	1 st Check Module	1
3	W-4302-00	2 nd Check Assembly	1
4	D-2422-00	2 nd Check O-Ring	1
5	L-6104-00	Check Spacer	1
6	F-3206-05	Cap	1
7	D-2568-00	Cap O-Ring	1

Repair Kit

4S-003-01

1, 2, 3, 4, 7, n/s packet lube

Parts Listing 3/4" - 2" (Bronze)

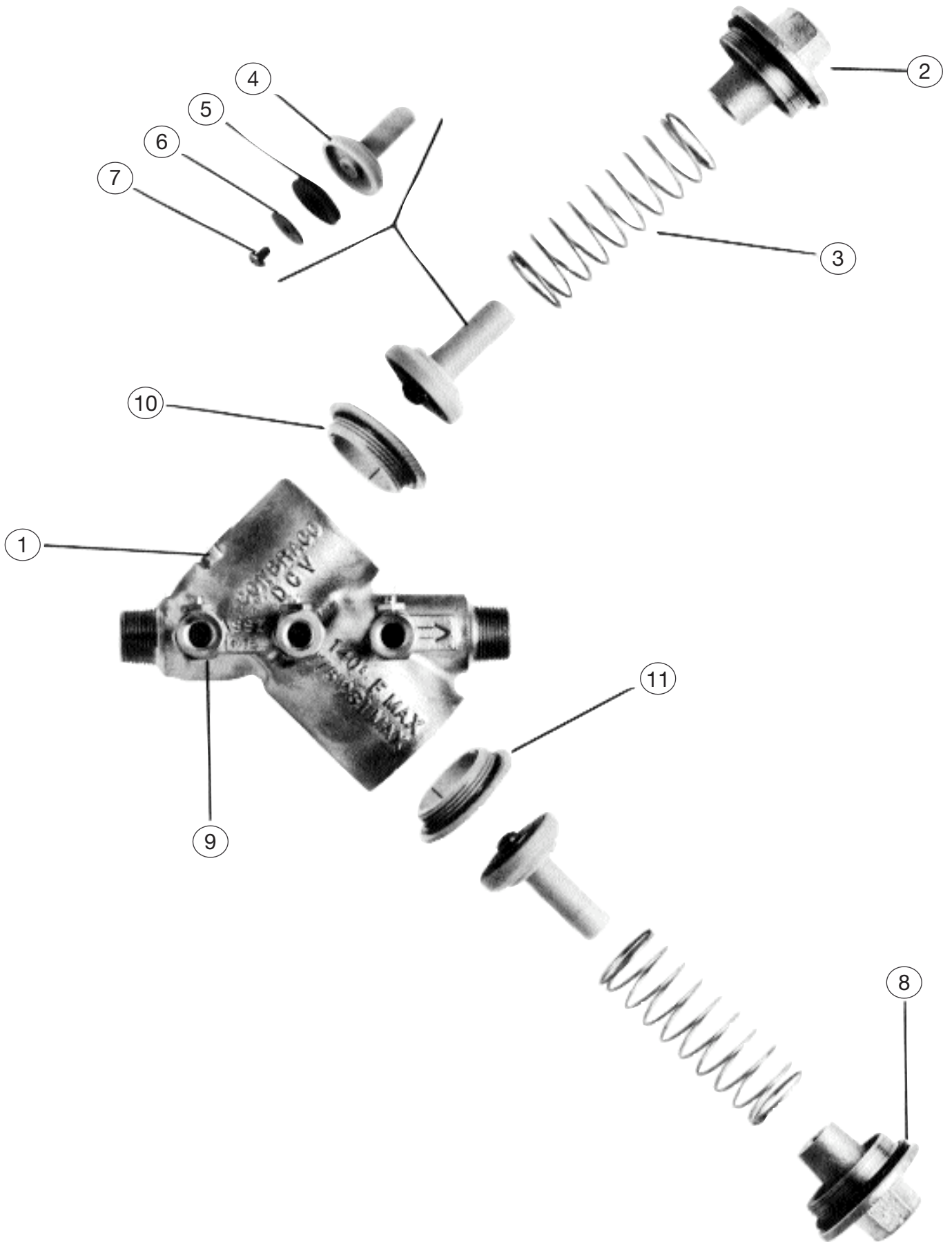

40-100

Double Check Backflow Preventer

ITEM NO.	DESCRIPTION	QUANTITY	PART NO.	
			3/4" & 1"	1-1/4", 1-1/2", 2"
1	Body	1	Consult Factory	Consult Factory
2	Cap	2	F-310805*	F-311505**
n/s	Plug	2	K-301200*	K301900**
3	Spring	2	A-170000	A-170100
4	Poppet	2	K-336200	K-336700
5	Seat Disc	2	D-250300	D-250800
6	Seat Retainer	2	D-249900	D-250900
7	Screw	2	B-175000	B-175000
8	Cap O-Ring	2	D-250000	D-251000
9	Test Cock	3	78-257-01	78-258-01
10	Check Seat	2	L-486400	L-486600
11	Check O-Ring	2	D-227400	D-256500

Repair Kits

Major Repair Kit

(4 (2), 5 (2), 6 (2), 7 (2), 8 (2),
10 (2), 11 (2)), n/s packet lube

40-004-A5

40-007-A5

Check Valve Repair Kit

(4, 5, 6, 7, 8, 10, 11), n/s packet lube

40-004-A2

40-007-A2

Rubber Repair Kit

(5 (2), 8 (2), 11 (2)), n/s packet lube

40-004-A6

40-007-A6

Replaceable Seat Kit

(10 (2), 11 (2)), n/s packet lube

40-004-A8

40-007-A8

Accessories

Double Check Valve Test Kit

40-200-TKU (3-Valve)

40-200-TK5U (5-Valve)

* 1/8" NPT plug needed for units without top mounted test cocks.

** 1/4" NPT plug needed for units without top mounted test cocks.

Parts Listing 3/4" - 2" (Bronze) Top Entry

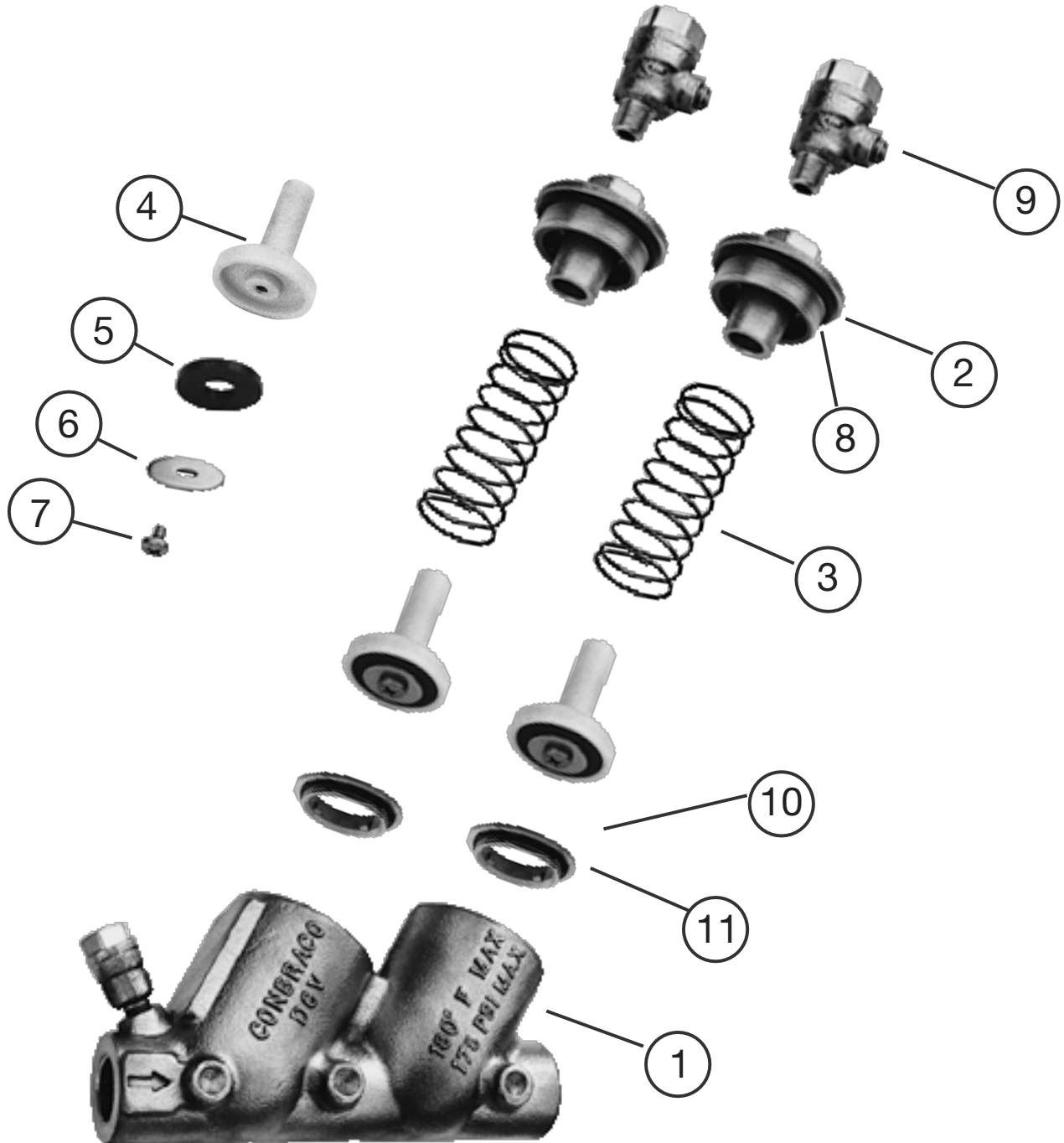

40-100-T SERIES

TOP ENTRY DOUBLE CHECK VALVE ASSEMBLY

ITEM NO.	DESCRIPTION	QUANTITY	PART NO.	
			3/4" & 1"	1-1/4", 1-1/2", 2"
1	Body	1	Consult Factory	Consult Factory
2	Cap	2	F-3108-05	F-3115-05
3	Spring	2	A-1700-00	A-1701-00
4	Poppet	2	K-3362-00	K-3367-00
5	Seat Disc	2	D-2503-00	D-2508-00
6	Seat Retainer	2	D-2499-00	D-2509-00
7	Screw	2	B-1750-00	B-1750-00
8	Cap O-Ring	2	D-2500-00	D-2510-00
9	Test Cock	3	78-257-01	78-258-01
10	Check Seat	2	L-4864-00	L-4866-00
11	Check O-Ring	2	D-2274-00	D-2565-00

Repair Kits

Major Repair Kit

(4 (2), 5 (2), 6 (2), 7 (2), 8 (2), 10 (2), 11 (2)), n/s packet lube 40-004-A5 40-007-A5

Check Valve Repair Kit

(4, 5, 6, 7, 8, 10, 11), n/s packet lube 40-004-A2 40-007-A2

Rubber Repair Kit

(5 (2), 8 (2), 11 (2)), n/s packet lube 40-004-A6 40-007-A6

Replaceable Seat Kit

(10 (2), 11 (2)), n/s packet lube 40-004-A8 40-007-A8

Accessories

Double Check Valve Test Kit 40-200-TKU (3-Valve)
40-200-TK5U (5-Valve)

2 1/2" - 3" - 4" DCV

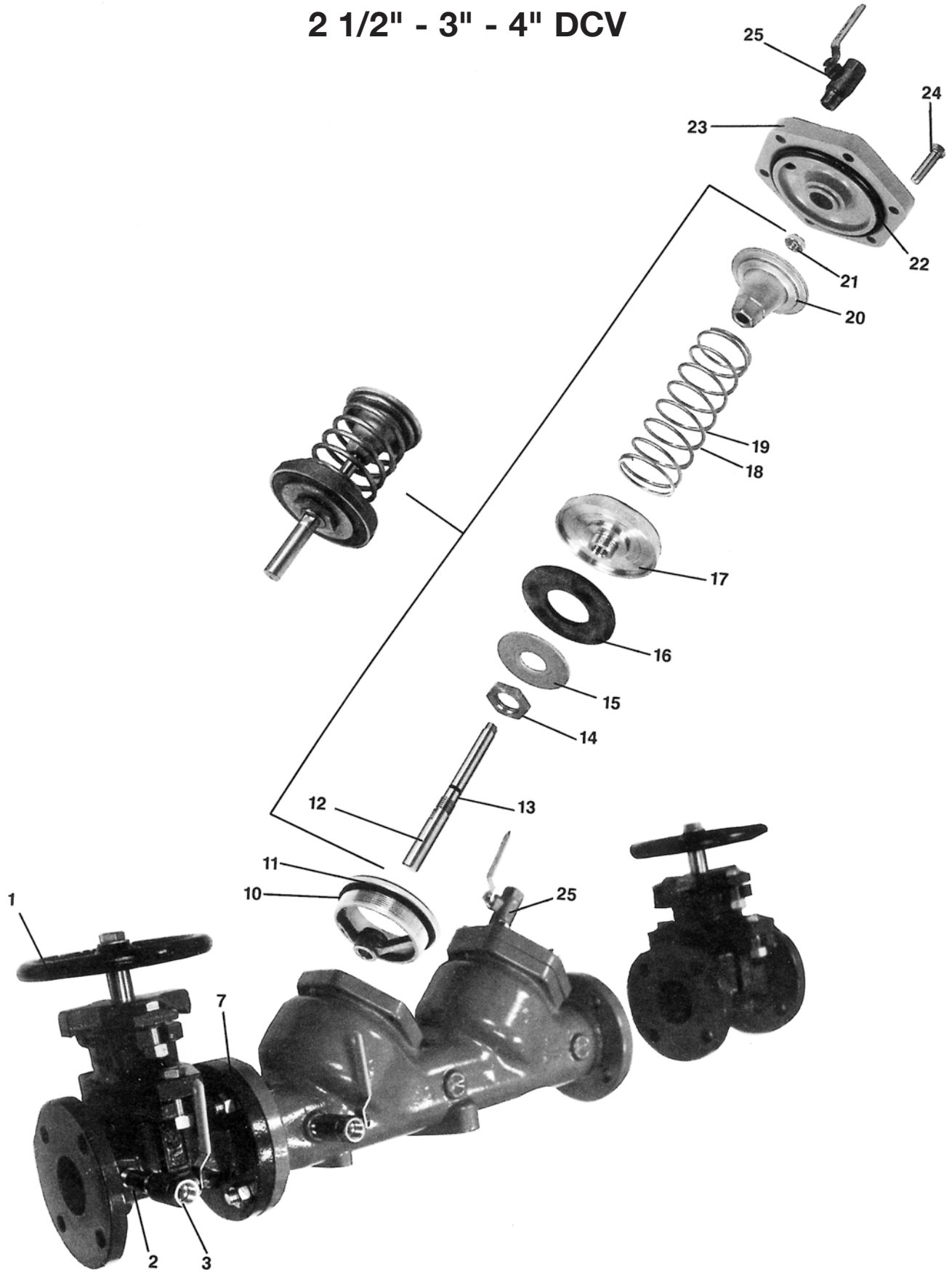

DCV

Parts List

ITEM NO.	DESCRIPTION	QUANTITY	PART NO.		
			2-1/2"	3"	4"
1	Shut-Off Valve (OS&Y)	2	W-6789-00	W-6790-00	W-6824-00
1	Shut-Off Valve (NRS)	2	W-6785-00	W-6786-00	W-6743-00
1	Shut-Off Valve (Ball)	2	6Q-209-01	6Q-200-01	6Q-20A-01
2	Brass Nipple	1	K-3406-00	K-3406-00	K-3406-00
3	Test Cock	1	70-103-01	70-103-01	70-103-01
7	Body	1	Q-4526-19	Q-4527-19	Q-4534-19
10	C.V. Seat O-Ring	2	D-2576-00	D-2567-00	D-2573-00
11	C.V. Seat	2	L-4637-05	L-4637-05	L-4640-05
12	C.V. Stem	2	G-3239-06	G-3239-00	G-3242-00
13	C.V. Stem O-Ring	2	D-2561-00	D-2561-00	D-2561-00
14	Retainer Nut	2	C-1756-00	C-1756-00	C-1756-00
15	Retainer Washer	2	E-2199-00	E-2199-00	E-2204-00
16	C.V. Seat Disc	2	D-2560-00	D-2560-00	D-2572-00
17	Seat Disc Holder	2	F-3000-05	F-3000-05	F-3001-05
18	1st Check Spring	1	A-1741-00	A-1741-00	A-1744-00
19	2nd Check Spring	1	A-1741-00	A-1741-00	A-1744-00
20	Spring Retainer	2	E-2198-05	E-2198-05	E-2202-05
21	Jam Nut	2	C-1589-05	C-1589-05	C-1589-05
22	Cap O-Ring	2	D-2566-00	D-2566-00	D-2574-00
23	C.V. Cap	2	Q-4530-19	Q-4530-19	Q-4533-19
24	Cap Bolt	12	B-1797-00	B-1797-00	B-1801-00
25	Test Cock	3	70-803-10	70-803-10	70-803-10

Repair Kits

<u>1st Check Valve Repair Kit</u>	40-009-02	40-009-02	40-00A-02
(12, 13, 14, 15, 16, 17, 18, 20, 21, 22), n/s packet lube			
<u>Seat Repair Kit</u>	40-009-03	40-009-03	40-00A-03
(10, 11, 22), n/s packet lube			
<u>Rubber Repair Kit</u>	40-009-04	40-009-04	40-00A-04
2 each (10, 13, 16, 22), n/s packet lube			

6" - 8" - 10" DCV

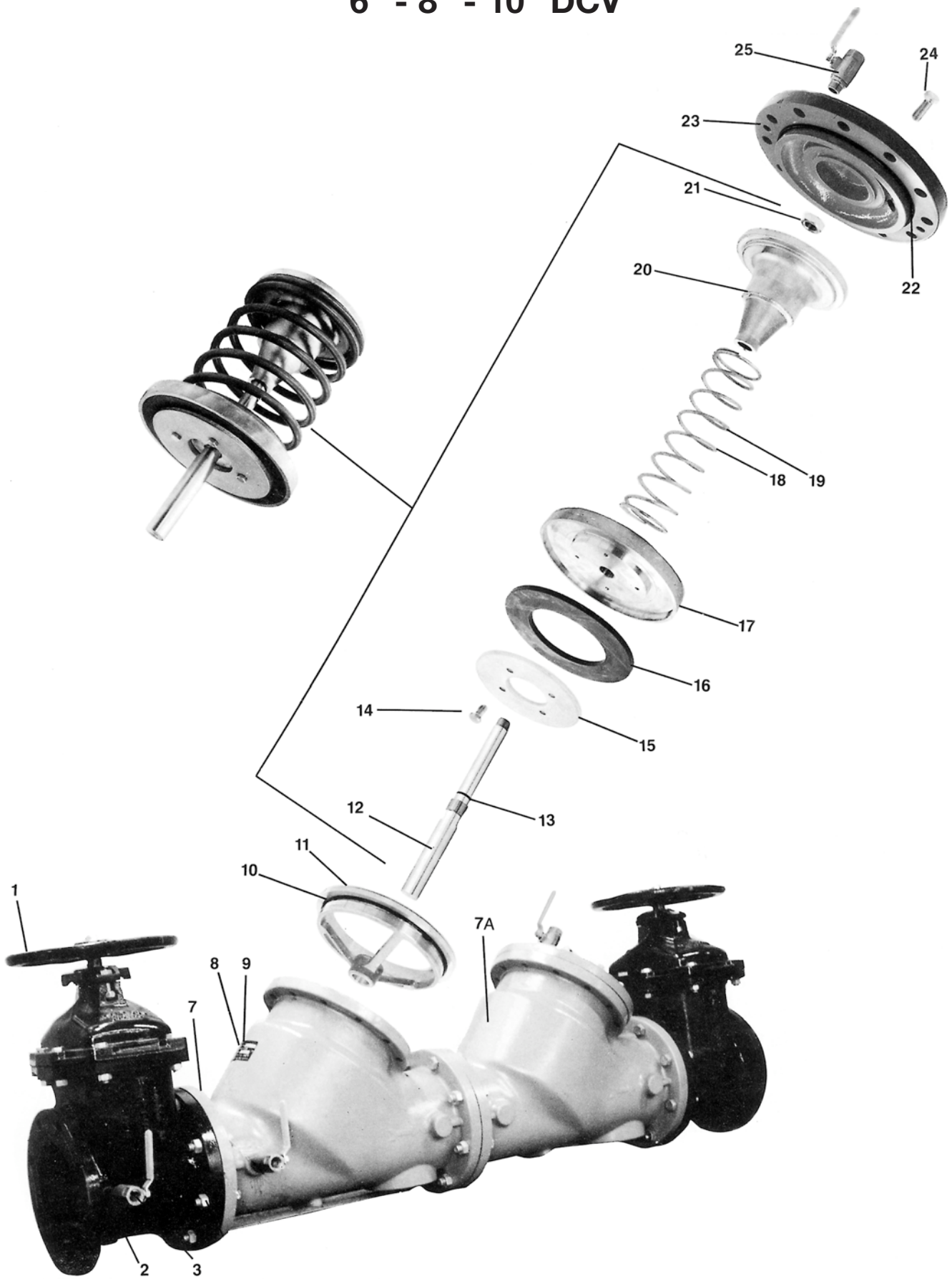

DCV

Parts List

ITEM NO.	DESCRIPTION	QUANTITY	PART NO.		
			6"	8"	10"
1	Shut-Off Valve (OS&Y)	2	W-6825-00	W-6826-00	W-6859-00
1	Shut-Off Valve (NRS)	2	W-6744-00	W-6827-00	W-6858-00
1	Shut-Off Valve (Ball)	2	6Q-20C-01	6Q-20E-01	N/A
2	Brass Nipple	1	K-3412-40	K-3412-00	K-3412-00
3	Test Cock	1	70-104-10	70-104-10	70-104-10
6A	Stud	2	N/A	N/A	B-2036-00
7	Body	1	Consult Factory	Consult Factory	Consult Factory
7A	Body	1	Consult Factory	Consult Factory	Consult Factory
10	C.V. Seat O-Ring	2	D-2576-00	D-2589-00	D-2588-00
11	C.V. Seat	2	L-4644-05	L-4653-05	L-4759-05
12	C.V. Stem	2	G-3246-00	G-3273-00	G-3305-00
13	C.V. Stem O-Ring	2	D-2578-00	D-2587-00	D-2587-00
14	Retainer Nut/Bolt	***	C-1760-00	B-1754-00	B-1754-00
15	Retainer Washer	2	E-2205-00	E-2208-00	E-2229-00
16	C.V. Seat Disc	2	D-2575-00	D-2586-00	D-2649-00
17	Seat Disc Holder	2	F-3002-05	F-3008-05	F-3019-05
18	1st Check Spring	1	A-1746-00	A-1748-00	A-1779-00
19	2nd Check Spring	1	A-1746-00	A-1748-00	A-1779-00
20	Spring Retainer	2	E-2203-05	E-2207-05	E-2228-05
21	Jam Nut	2	C-1706-00	C-1763-00	C-1763-00
22	Cap O-Ring	2	D-2577-00	D-2588-00	D-2651-00
23	C.V. Cap	2	Q-4537-19	Q-4545-19	Q-4574-19
24	Cap Bolt	****	B-1800-00	B-1690-00	B-1881-00
25	Test Cock	3	70-804-10	70-804-10	70-804-10
N/S	Seat Bolt	12	N/A	N/A	B184900

*** 6" QTY = 2 / 8" & 10" QTY = 8

**** 6" QTY = 12 / 8" & 10" QTY = 24

Repair Kits

<u>Check Valve Repair Kit</u>	40-00C-02	40-00E-02	40-00G-02
(12, 13, 14, 15, 16, 17, 18, 20, 21, 22), n/s packet lube			
<u>Seat Repair Kit</u>	40-00C-03	40-00E-03	40-00G-03
(10, 11, 22), n/s packet lube			
<u>Rubber Repair Kit</u>	40-00C-04	40-00E-04	40-00G-04
2 each (10, 13, 16, 22), n/s packet lube			

3" - 4" DCDA

Notes:

1. Use P/N W-7062-00 for meter in cubic feet register.
Use P/N W-7094-00 for meter in gallons register.

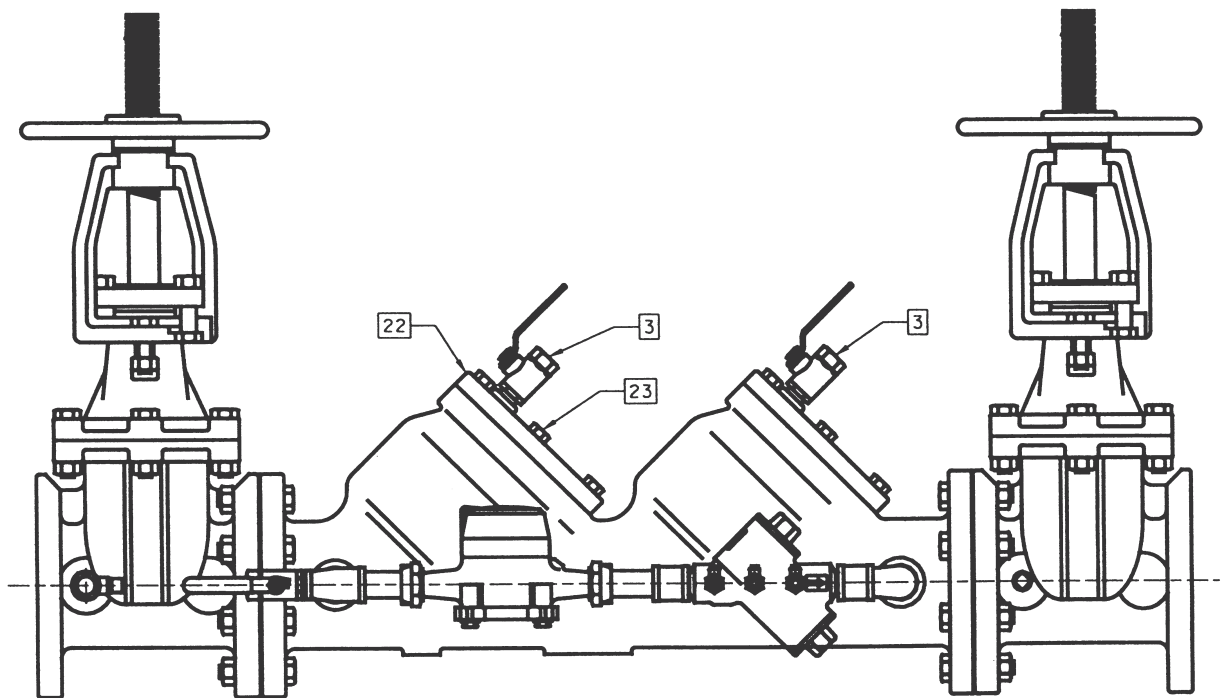
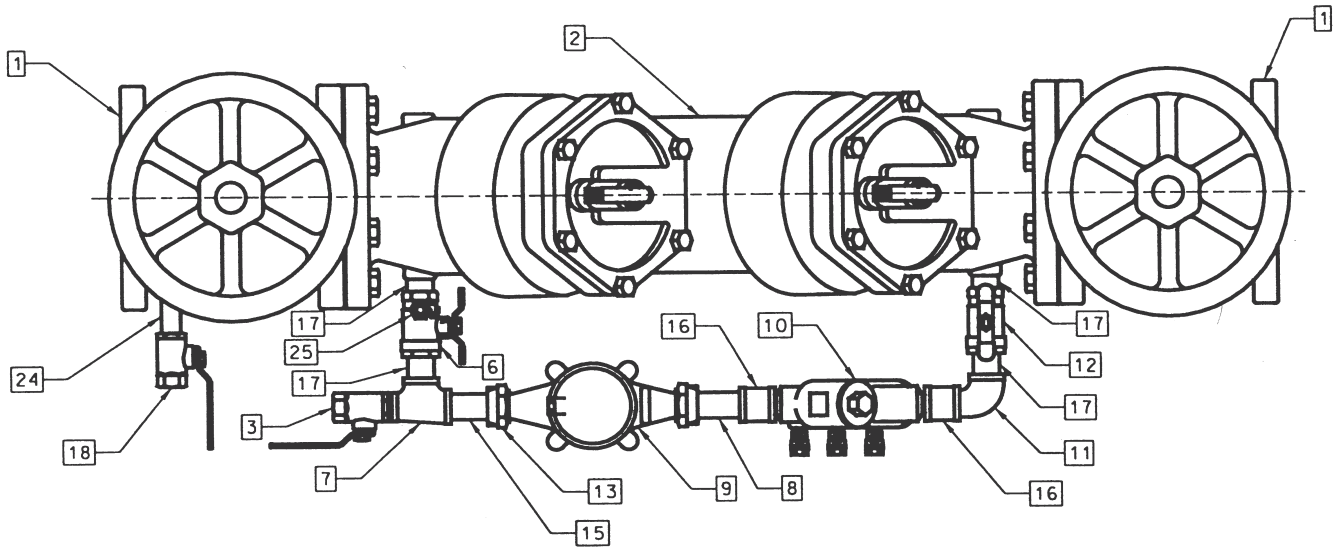

DCDA Parts List

ITEM NO.	DESCRIPTION	QUANTITY	PART NO.	
			3"	4"
1	Gate Valve (OS&Y)	2	W679000	W682400
2	DCDA Body	1	Contact Factory	Contact Factory
3	Test Cock	3	7080310	7080310
N/S	1st Chk Poppet Ass'y	1	W710705	W710005
N/S	2nd Chk Poppet Ass'y	1	W671805	W673105
6	By-Pass Shut-Off Valve	1	7B10401	7B10401
7	Tee, Reducing	1	K350600	K350600
8	Coupling, Water Meter	1	K350500	K350500
9	Water Meter in Cubic Feet	1	W706200	W706200
9	Water Meter in Gallons	1	W709400	W709400
10	3/4" DCV	1	W378905	W738905
11	Elbow, Street	*	K350200	K350200
12	By-Pass Shut-Off Valve	1	7B10431	7B10431
13	Swivel Nut	1	N/A	C186705
N/S	Washer, Meter	1	N/A	D261000
15	Coupling	1	N/A	K379106
16	3/4" Coupling	2	N/A	K350400
17	Nipple, Close	**	K337000	K337000
18	Test Cock	1	7010310	7010310
22	Cap	2	Q453019	Q453319
23	Cap Bolt	12	B179700	B180100
24	Nipple	1	K340600	K340600
25	Test Cock	1	7825701	7825701
N/S	Nipple, 3/4" x 3" Lg.	2	K341200	N/A
N/S	Elbow, 3/4" - 90°	1	K350100	N/A
N/S	Cap O-Ring	2	D256600	D257400
N/S	Seat O-Ring	2	D256700	D257300
N/S	Plug, 1/2"	1	K300800	K300800
N/S	Check Valve Seat	2	L463705	L464005
N/S	Meter to DCV Adapter	1	L522806	N/A

* 3" QTY = 3 / 4" QTY = 1

** 3" QTY = 2 / 4" QTY = 4

6" - 8" - 10" DCDA

Notes:

1. Use P/N W-7062-00 for meter in cubic feet register.
Use P/N W-7094-00 for meter in gallons register.

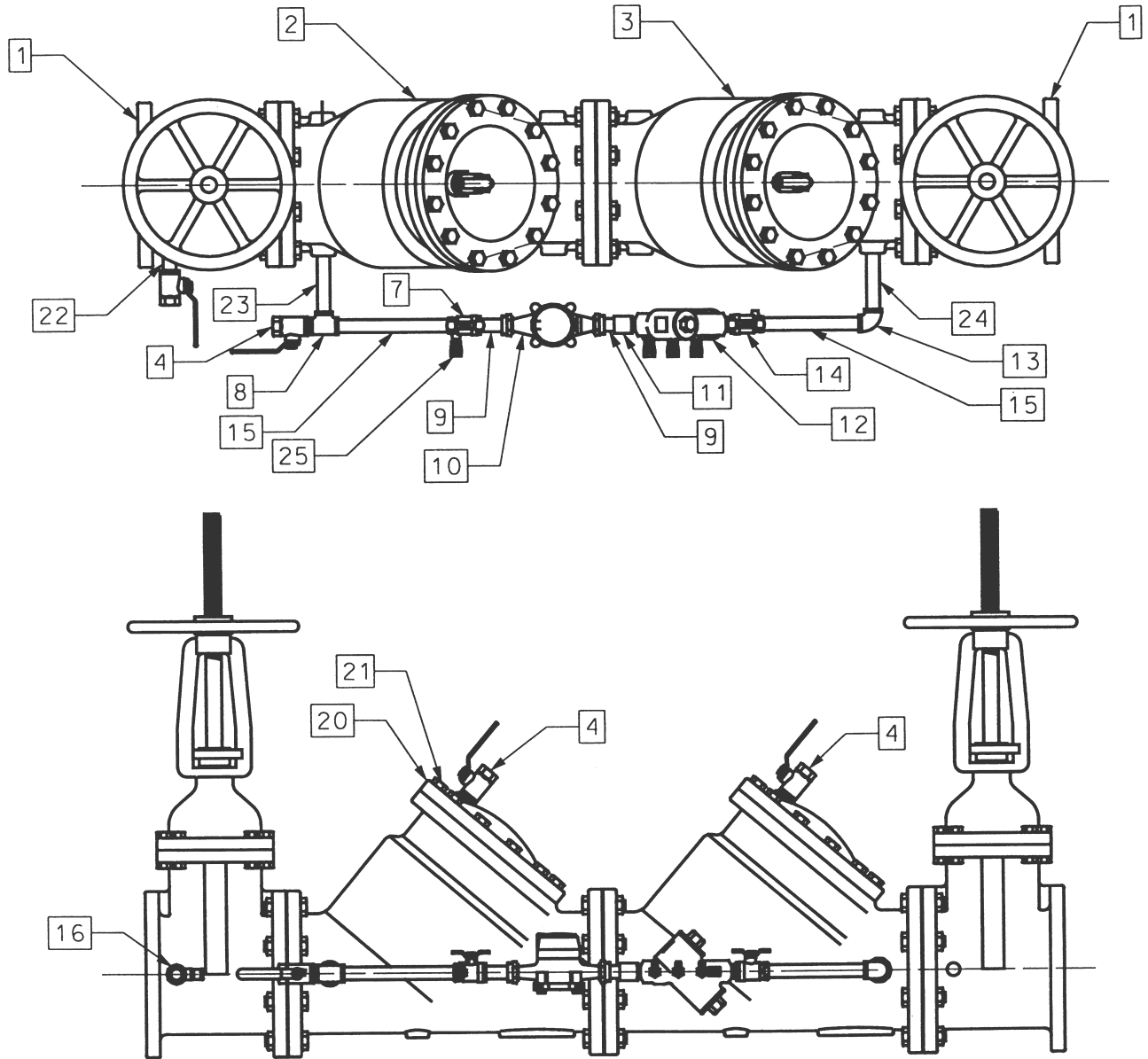

DCDA

Parts List

ITEM NO.	DESCRIPTION	QUANTITY	PART NO.		
			6"	8"	10"
1	Gate Valve (OS&Y)	2	W682500	W682600	W685900
2	Body (1st Check)	1	Contact Factory	Contact Factory	Contact Factory
3	Body (2nd Check)	1	Contact Factory	Contact Factory	Contact Factory
4	Ball Valve	3	7080410	7080410	7080410
N/S	1st Chk Poppet Ass'y	1	W706605	W708505	W711305
N/S	2nd Chk Poppet Ass'y	1	W674205	W674605	W685705
7	By-Pass Shut-Off Valve	1	7B10401	7B10401	7B10401
8	Tee, 3/4" NPT	1	K351100	K351100	K351100
9	Coupling, Water Meter	2	K350500	K350500	K350500
10	Water Meter in Cubic Feet	1	W706200	W706200	W706200
10	Water Meter in Gallons	1	W709400	W709400	W709400
11	Coupling, 3/4"	1	K350400	K350400	K350400
12	3/4" DCV	1	W738905	W738905	W738905
13	Elbow, 3/4" NPT	1	K350100	K350100	K350100
14	By-Pass Shut-Off Valve	1	7B10431	7B10431	7B10431
15	Nipple, 3/4" NPT	2	K350900	K352700	K356000
16	Ball Valve	1	7010410	7010410	7010410
20	Cap	2	Q453719	Q454519	Q457419
21	Cap Bolt	*	B180000	B169000	B188100
22	Nipple, 3/4" NPT	1	K341200	K341200	K341200
23	Nipple, 3/4" x 5-1/2" Lg.	1	K350900	K350900	K350900
24	Nipple, 3/4" NPT	1	K350900	K350900	K355900
25	Test Cock	1	7825701	7825701	7825701
N/S	Elbow, 3/4" - 90°	1	K350100	K350100	K350100
N/S	Cap O-Ring				

* 6" QTY = 12 / 8" & 10" QTY = 24

Conbraco Industries Statement of Warranty & Limitation of Liability

Conbraco Industries Inc. warrants, to its initial purchaser only, that its products which are delivered to this initial purchaser will be of the kind described in the order or price list and will be free of defects in workmanship or material for a period of two years from the date of delivery to you, our initial purchaser.

Should any failure to conform to this warranty appear within two years after the date of the initial delivery to our initial purchaser, Conbraco will, upon written notification thereof and substantiation that the goods have been stored, installed, maintained and operated in accordance with Conbraco's recommendations and standard industry practice, correct such defects by suitable repair or replacements at Conbraco's own expense.

THIS WARRANTY IS EXCLUSIVE AND IS IN LIEU OF ANY IMPLIED WARRANTY OF MERCHANTABILITY, FITNESS FOR A PARTICULAR PURPOSE OR OTHER WARRANTY OF QUALITY, WHETHER EXPRESSED OR IMPLIED, EXCEPT THE WARRANTY OF TITLE AND AGAINST PATENT INFRINGEMENT. Correction of non-conformities in the manner and for the period of time provided above, shall constitute fulfillment of all liabilities of Conbraco to our initial purchaser, with respect to the goods, whether based on contract, negligence, strict tort or otherwise. It is the intention of Conbraco Industries, Inc. that no warranty of any kind, whether, express or implied, shall pass through our initial purchaser to any other person or corporation.

LIMITATION OF LIABILITY: Conbraco Industries, Inc. SHALL NOT UNDER ANY CIRCUMSTANCES BE LIABLE FOR SPECIAL OR CONSEQUENTIAL DAMAGES SUCH AS, BUT NOT LIMITED TO, DAMAGES OR LOSS OF OTHER PROPERTY OR EQUIPMENT, LOSS OF PROFITS OR REVENUE, COST OF CAPITAL, COST OF PURCHASED OR REPLACEMENTS GOODS, OR CLAIMS OF CUSTOMERS OF OUR INITIAL PURCHASER, AND ALL OTHERS, SET FORTH HEREIN ARE EXCLUSIVE, AND THE LIABILITY OF CONBRACO WITH RESPECT TO SAME SHALL NOT, EXCEPT AS EXPRESSLY PROVIDED HEREIN, EXCEED THE PRICE OF THE GOODS UPON WHICH SUCH LIABILITY IS BASED.

"Apollo" Valves

Manufactured by Conbraco Industries Inc.

SERVICE AND SALES DEPARTMENT P.O. Box 247 • Matthews, NC 28106 Phone: 704-841-6000 • Fax: 704-841-6020

			E-Mail Address	Phone	Fax
Southeast Region	B. Lynch & Associates	Florida	sales@blynchandassociates.com	813-792-5060	813-792-5213
	Spotswood Associates	Georgia/Alabama	dlewis@spotswoodassociates.com	770-447-1227	770-263-6899
	Pro Marketing, Inc.	North Carolina/South Carolina/Tennessee-East	sales@promarketinginc.net	864-578-4334	864-578-4889
	Mid South Marketing, Inc.	Virginia/Maryland/Washington, D.C./WV-East	midsouth7@aol.com	804-213-3801	804-213-3802
Southern Region	Southern Marketing Group	MS/TN-West/AR/Bowie Cty.-TX	SMG49@bellsouth.net	901-547-0042	901-547-0035
	AVC Mechanical Sales, Inc.	Oklahoma/Texas-North	valvesales@avalve.com	214-201-0100	214-201-0104
	Armstrong/Weatherly Associates	Texas-South/Louisiana	sales@armstrong-weatherly.com	713-692-5566	713-692-6021
Midwestern Region	HEBCO, Inc.	Kansas/Missouri-West	kcwinelvr@aol.com	913-491-0797	913-491-5126
	New Tech Marketing	IL/WI-East/IN-North/MI-Upper Peninsula/IA-/River Counties	ntm012@mcleodusa.net	630-378-4300	630-378-0343
	New Tech Marketing	Eastern Missouri/Southern Illinois	ntm112@aol.com	618-394-0329	618-394-0427
	Whitfill-McCarthy, LLC	Kentucky/Indiana-South/Ohio-South	whitfill@win.net	502-459-4545	502-459-9944
	V.E. Sales Co., Inc.	Michigan (Except Upper Peninsula)	tomv@vesalesinc.com	586-774-7760	586-774-1490
	Fourmation Sales	Minnesota/North & South Dakota/Wisconsin-West	dean@fourmationsales.com	763-262-4700	763-262-4740
	Willco, Inc.	Nebraska/Iowa (Except River Counties)	bill@willcoinc.com	402-573-7000	402-573-7371
Midwest Spec	Ohio-North/Pennsylvania-West/West Virginia-West	glsales@mwspec.com	330-538-0406	330-538-0410	
Western Region	Elmco and Associates	California-North	kkleinen@elmcoassoc.com	916-383-0110	916-383-0181
	Spec Management Group	California-South (Irrigation), Hawaii (All Products)	msmarch4@cox.net	949-481-4225	949-487-0990
	Cisco Speciality Products, Inc.	California-South	ciscoemail@aol.com	714-921-9228	714-921-0442
	Marshall-Rodeno Associated	CO/WY/MT/ID-SE/UT/NV-NE/NM/EI Paso-TX	trodeno@marshallrodeno.com	303-575-6701	303-575-6706
	Bralely-Gray & Associates	Oregon/SW Washington/Western Idaho	sales@braleygray.com	503-249-6972	503-288-4464
	Bralely-Gray Washington	Alaska/Washington	info@braleygray.com	206-405-4370	206-405-4390
	Southwestern Industrial Sales Co.	Arizona/Nevada-SW	eduardop@sw-ind.com	480-458-5838	480-458-5843
	Jack Prust Sales	California-North (Irrigation)	jack@jpsales.com	530-878-2922	530-878-2341
Active Sales Northwest, Inc	Oregon, WA, Western Idaho (Irrigation)	skactive@aol.com	541-726-0320	541-726-1148	
Northeast Region	Urell, Inc.	Massachusetts/New England States	conbraco@urell.com	617-923-9500	617-926-9414
	McMahon Marketing, Inc.	New York-Upstate/New York-West	sales@mcmahonmarketing.com	518-792-3350	518-792-3351
	Continuous Sales Corporation	New York-East/New Jersey-North	csc07@aol.com	516-575-6800	516-349-8411
	Layden Company	Pennsylvania-East/Delaware/New Jersey-South	joejr@laydencompany.com	610-363-6657	877-529-3361
Keith Engle & Associates	OEM accounts	keith.enge@verizon.net	610-827-9560	610-827-9561	
Canada	Conbraco Industries, Canada	160 Pennsylvania Ave., Unit 3, Concord, Ontario L4K 4A9	conbraco.canada@conbraco.com	905-761-6161	905-761-6666
	Barclay Sales Ltd.	British Columbia	bbarclay@barclaysales.com	604-945-1010	604-945-3030
	Dynamic Agencies, Ltd.	Saskatchewan	doug.dynamicage@sasktel.net	306-343-1901	306-343-1901
	Tom Beggs Agencies Ltd.	Manitoba/NW Ontario	TBA@MB.SYMPATICO.CA	204-953-1900	204-774-6915
	Task Controls, Inc.	Ontario	infotoronto@taskcontrols.com	416-291-3004	416-754-3481
	Agences J. Pierre Sylvain, Inc.	Quebec	agencespsylvain@golden.net	450-655-9588	450-641-2737
	Kern Industries, Ltd.	Alberta-North	kernind@telusplanet.net	780-451-2056	780-454-6687
	Kern Industries Calgary, Ltd.	Alberta-South	kerncalgary@telus.net	403-730-7791	403-239-8179
	J. Levandier Sales, Inc.	Nova Scotia, New Brunswick, Prince Edward Island and Newfoundland	jssales@istar.ca	506-858-1615	506-858-1084
	Key to the North Sales Agency, Inc.	Ontario-North	hmehes@keytothenorth.ca	705-524-6714	705-566-0148
Steam and Industrial Equipment	Ottawa	sie@sie.ca	1-800-363-8482	514-457-7111	
Int'l / Puerto Rico	Rafael Rodriguez Barril, Inc.	Puerto Rico	raulirrbarril.com	787-982-1550	787-982-1570
	Conbraco International Limited	Manchester, England	sales@conbraco.co.uk	44-161-212-3745	+44-161-212-3747

For Representatives And Distributors In Your International Area
Please Contact The Closest Conbraco Industries International Office.

Conway, SC • Matthews, NC • Pageland, SC • Customer Service 1-704-841-6000 • www.apollovalves.com