



**GAS HOT PLATE
MG-2/MG-4**

MANUAL

IMPORTANT:

THE USER'S MANUAL PROVIDES SPECIFIC OPERATING INSTRUCTIONS FOR YOUR MODEL. USE THE GAS HOT PLATE ONLY AS INSTRUCTED IN THIS MANUAL.

KEEP A COPY OF YOUR BILL OF SALE.

The date on the bill establishes the warranty period should service be required. If service is performed, it is in your interest to obtain and keep all receipts.

KEEP THIS MANUAL FOR TRAINING NEW PERSONNEL.

Record the Serial number and Model number of this Gas Hot Plate in the spaces provided. **Keep these numbers for future reference.**

SERIAL NUMBER

MODEL NUMBER

Keating commercial Hot Plates are not intended for household use.

As continuous product improvement occurs, specifications may be changed without notice.

1-800-KEATING | keatingofchicago.com

NOTE:

PURCHASER SHOULD POST IN A PROMINENT LOCATION INSTRUCTIONS TO BE FOLLOWED IN THE EVENT THE USER SMELLS GAS. THIS INFORMATION SHALL BE OBTAINED BY CONSULTING THE LOCAL GAS SUPPLIER.



WARNING

Improper installation, adjustment, alteration, service or maintenance can cause property damage, injury or death. Read the installation, operating and maintenance instructions thoroughly before installing or servicing this equipment.



FOR YOUR SAFETY:

Do not store or use gasoline or other flammable vapors or liquids in the vicinity of this or any other appliance.

WARNING

IF NOT INSTALLED, OPERATED AND MAINTAINED IN ACCORDANCE WITH THE MANUFACTURER'S INSTRUCTIONS, THIS PRODUCT COULD EXPOSE YOU TO SUBSTANCES IN FUEL OR IN FUEL COMBUSTION WHICH CAN CAUSE DEATH OR SERIOUS ILLNESS AND WHICH ARE KNOWN TO THE STATE OF CALIFORNIA TO CAUSE CANCER, BIRTH DEFECTS OR OTHER REPRODUCTIVE HARM.

WARNING

PROPANE GAS MAY EVENTUALLY LOSE ITS ODOR AND PRECAUTIONS SHOULD BE TAKEN TO ASSURE THAT PROPANE GAS IS NOT PRESENT EVEN THOUGH YOU DO NOT DETECT AN ODOR. IF THERE IS ANY DOUBT, YOU SHOULD CALL YOUR LOCAL PROPANE GAS SUPPLIER FOR ASSISTANCE.



■ TABLE OF CONTENTS

| | |
|-------------------------------------|--------------|
| Important Safety Instructions | i |
| INTRODUCTION | 1 |
| INSTALLATION | |
| Damage During Shipment | 1 |
| Options | 2 |
| Standard Features..... | 2 |
| Ratings..... | 2 |
| Options | 2 |
| Safety Precautions | 2 - 3 |
| FIRST STEPS | |
| National Code Requirement | 3 |
| Positioning..... | 3 |
| Restraining Devices..... | 3 |
| Gas Connection | 4 |
| Electrical Connection | 4 |
| Gas Leak Testing..... | 4 |

PLACING YOUR KEATING HOT PLATE IN OPERATION

| | |
|------------------------------------|--------------|
| Lighting | 4 - 5 |
| Shutdown | 5 |
| Cleaning..... | 5 |
| PREVENTATIVE MAINTENANCE | |
| Warranty Repairs | 5 |
| Preventive Maintenance Chart | 5 |
| SERVICE DIAGNOSIS | |
| Troubleshooting..... | 6 |
| ORDERING PARTS | 6 |
| Warning and Operating Plates..... | 6 |
| Parts List..... | 7 - 8 |
| Hot Plate Assembly | 8 |
| Wiring Diagram..... | 9 |
| Warranty Information | 10 |

■ INTRODUCTION

Instructions in this manual should be read thoroughly before attempting to operate the Keating Gas Hot Plate. All installation and service on Keating equipment must be performed by qualified, certified, licensed and/or authorized installation or service personnel.

Operating information for Keating equipment has been prepared for use by qualified and/or authorized personnel.

Keating equipment is made in the USA and has American sizes of hardware. All metric conversions are approximate.

■ INSTALLATION INSTRUCTIONS

Proper installation will assure top performance. Alterations of any kind to your equipment will void the warranty. Before uncrating, check equipment carefully for damage.

IF EQUIPMENT ARRIVES DAMAGED

Keating does not assume responsibility for loss or damage incurred in transit.

IMPORTANT

This merchandise has been thoroughly inspected and carefully packed before leaving our plant. Responsibility for its safe delivery was assumed by the carrier at the time of shipment. Claims for loss or damage to the contents should, therefore, be made upon the carrier, as follows:

CONCEALED LOSS OR DAMAGE

Concealed loss or damage means loss or damage which does not become apparent until the merchandise has been unpacked. The contents may be damaged in transit due to rough handling even though

the carton may not show external damage. When the damage is discovered upon unpacking, make a written request for inspection by the carrier's agent within fifteen days of the delivery date. Then file a claim with the carrier since such damage is the carrier's responsibility. By following these instructions carefully, we guarantee our full support of your claims to protect you against loss from concealed damage.

VISIBLE LOSS OR DAMAGE

Any external evidence of loss or damage must be noted on the freight bill or express receipt, and signed by the carrier's agent. Failure to adequately describe such external evidence of loss or damage may result in the carrier refusing to honor a damage claim. The form required to file such a claim will be supplied by the carrier.

DO NOT RETURN DAMAGED MERCHANDISE TO KEATING. FILE YOUR CLAIM AS STATED ABOVE.

Keating MG-2 and MG-4 Hot Plates are designed to give maximum production efficiency, delivering high quality food products. The following design features are incorporated in all Keating Hot Plates.

STANDARD FEATURES

- Highly polished stainless steel front
- Infinite controls
- 12" working height
- Gas and air adjustments
- Easy access for servicing
- 3/4" gas connection
- 100% factory testing

RATINGS

- 15,000 BTU/hr. input per burner (natural gas and Propane)
- 4" WC (natural gas) or 10" WC (Propane) burner gas pressure
- 49 (natural gas) or 53 (Propane) burner orifice size
- 3/4" gas supply pipe recommended

OPTIONS

- Natural Gas or Propane
- Spark Ignition System
- 24" or 30" depth

MODEL VARIATIONS

MG-2 Model: The MG-2 model has two burners

MG-4 Model: The MG-4 model has four burners

SAFETY PRECAUTIONS

⚠ WARNING

THIS SYMBOL WARNS YOU THAT SERIOUS BURNS OR OTHER INJURIES MAY RESULT IF SAFETY INSTRUCTIONS ARE NOT FOLLOWED.

- This service manual should be retained in a safe place for future reference. The installation of your new hot plate must conform to local codes or in the absence of local codes, with the current National Fuel Gas Code ANSI Z223.1/NFPA 54 (latest edition), Natural Gas Installation Code CAN/CGA-B149.1 or Propane Installation Code CAN/CGA-B149.2.
- Your ventilation hood, when installed, must conform to the current ANSI/NFPA 96 standard (latest edition).

- No frame or restriction shall be constructed around the hot plate that will restrict air movement into the hot plate's combustion area or prevent proper ventilation.
- Keating hot plates are designed to operate on the gas fuel specified on the serial plate and must not be operated with another gas fuel. They cannot be converted to another gas fuel by turning or engaging a switch.

⚠ WARNING

DO NOT STORE OR USE GASOLINE OR OTHER FLAMMABLE VAPORS AND LIQUIDS IN THE VICINITY OF THIS OR ANY APPLIANCE.

You will post, in a prominent location, instructions to be followed in the event the user smells gas. This information shall be obtained from your local gas supplier.

IMPORTANT: IN THE EVENT A GAS ODOR IS DETECTED, SHUT DOWN UNIT AT MAIN SHUT-OFF VALVE AND CONTACT THE LOCAL GAS COMPANY OR GAS SUPPLIER FOR EMERGENCY SERVICE.

- Suitable for installation on combustible surfaces.
- You must maintain this appliance free and clear from combustibles.
- You must maintain the following minimum clearances from combustible and non-combustible construction:

MINIMUM CLEARANCE

| CONSTRUCTION CLEARANCES | | |
|--------------------------------|--------------------|------------------------|
| | COMBUSTIBLE | NON-COMBUSTIBLE |
| BACK | 6" | 0" |
| RIGHT SIDE | 6" | 0" |
| LEFT SIDE | 6" | 0" |

- You must install this appliance at least 16 inches away from any open flame.
- Adequate clearance for servicing and proper operation must be maintained. Your hot plate is designed to be serviced from the front.
- Keating commercial hot plates are not intended for household use.
- ALWAYS instruct new employees on proper hot plate operation.
- A hot plate should be operated ONLY by properly trained personnel.
- ALWAYS turn hot plate off each night.
- ALWAYS disconnect fuel source before servicing.
- NEVER leave a hot plate unattended during operation.

- NEVER introduce objects into hot plate, while operational, which are not designed or made for cooking.
- THIS HOT PLATE MAY NOT BE ALTERED, MODIFIED OR CHANGED IN ANY WAY.

The State of California enacted the California Safe drinking water and Toxic Enforcement Act of 1986, (Prop. 65), which “prohibits any person in the course of doing business from knowingly and intentionally exposing any individual to a chemical known to the State of California to cause cancer or reproductive toxicity without first giving clear and reasonable warning to such individuals.” The Governor’s Scientific Advisory Panel added carbon monoxide to the list of hazardous chemicals known to cause reproductive harm.

Carbon monoxide would not be present in concentrations that would pose a “significant risk” to the consumer when the equipment is installed, operated and maintained as follows:

- Installed under a properly designed operating exhaust hood.
- Connected to the type of gas for which the appliance is manufactured.
- Pressure regulator is installed in the appliance and adjusted for the manifold pressure marked on the serial plate.
- Adequate air supply to the appliance.
- In-line pressure regulator, not supplied by Keating, must be installed outside the appliance.
- The equipment is operated in the manner intended using the proper utensils.
- Keep the equipment clean and have it checked periodically.
- Burner air adjustments, mechanical maintenance and repairs must be performed by qualified service personnel.

If the equipment is not installed, operated and maintained in accordance with the above, concentrations of carbon monoxide in excess of the established limits could be present in the kitchen environment.

ALL PERSONNEL IN THE WORK PLACE WHO MAY BE SUBJECT TO ANY EXPOSURE OF CARBON MONOXIDE MUST BE WARNED OF SUCH POSSIBLE EXPOSURE. THIS WARNING SHOULD BE CONVEYED IN A MANNER SO THAT IT IS CLEARLY UNDERSTOOD BY THE EMPLOYEE, AND THE EMPLOYEE SHOULD BE ASKED IF IN FACT HE OR SHE UNDERSTANDS THE CORRECT METHOD OF OPERATION OF THE EQUIPMENT AND THAT A RISK OF EXPOSURE EXISTS IF THE EQUIPMENT IS OPERATED IMPROPERLY.

⚠ WARNING

IF NOT INSTALLED, OPERATED AND MAINTAINED IN ACCORDANCE WITH THE MANUFACTURER’S INSTRUCTIONS, THIS PRODUCT COULD EXPOSE YOU TO SUBSTANCES IN FUEL OR IN FUEL COMBUSTION WHICH CAN CAUSE DEATH OR SERIOUS ILLNESS AND WHICH ARE KNOWN TO THE STATE OF CALIFORNIA TO CAUSE CANCER, BIRTH DEFECTS OR OTHER REPRODUCTIVE HARM.

■ FIRST STEPS

NATIONAL CODE REQUIREMENT

The installation must conform with local codes, or in the absence of local codes, with the National Fuel Gas code, ANSI Z223.1 or the Natural gas Installation Code, CAN/CGA-B149.1 or the Propane Installation Code, CAN/CGA-B149.2. Flexible connectors must comply to ANSI Z221.69/CAN/CGA1.16.

When pressure testing at test pressures less than or equal to 1/2 psig (3.45 KPA), hot plate **must be isolated** from gas supply piping. When pressure testing at test pressures above 1/2 psig (3.45 KPA), hot plate **must be disconnected** from gas supply piping system.

POSITIONING

The hot plate must be no closer than 6" from any combustible material and 16" away from any open flame. The hot plate must be placed under an exhaust hood with a fire retardant system. Your ventilation hood, when installed, must conform to the current ANSI/NFPA 96 standard. **ALL** connections and placement must comply with local and national codes. It is the responsibility of the owner and local installer to comply with these regulations when installing the hot plate.

RESTRAINING DEVICES

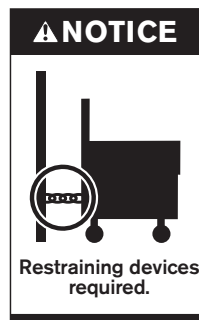

Hot plates **must be restrained to prevent tipping** when installed in order to avoid splashing, spilling, etc. of hot liquid. The restraining method may be a manner of installation or by separate means. Adequate means must also be provided to limit the movement of the appliance without depending on the connector, the quick-disconnect

device or its associated piping to limit the appliance movement.

Connectors must comply with the current ANSI Z21.69/CAN 1 6.10-88 standard for connectors for movable gas appliances. Quick-disconnect devices must comply with the current ANSI Z21.41/CAN 1 6.9-M79 standard for quick-disconnect devices meet these standards.

GAS CONNECTION

⚠ WARNING

- **PIPE JOINT COMPOUNDS RESISTANT TO PROPANE GASES MUST BE USED.**
- **BEFORE OPERATING THIS HOT PLATE, CHECK PIPE JOINTS FOR LEAKS BY USING A SOAP AND WATER SOLUTION ONLY. DO NOT USE AN OPEN FLAME!**

Figure 1

Main Gas Connection

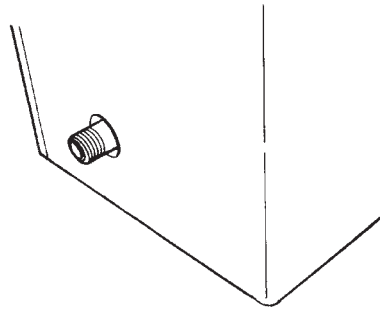

FOR YOUR SAFETY: Do not store or use gasoline or other flammable vapors and liquids in the vicinity of this or any other appliance.

Connect the hot plate to the main gas supply line at the rear of the hot plate. The piping should be a minimum of 3/4" IPS supply pipe for a single hot plate.

A 3/4" NPT manual gas valve is shipped with each single hot plate for field installation. The required gas pressure for proper operation of each hot plate is 4" water column for natural gas and 10" water column for Propane gas.

In-line pressure regulators are not supplied by Keating. They are to be provided and installed by others as directed by local codes.

NOTE: If more than one gas hot plate is on the same supply line, you may require a larger line. Consult your local gas company to assure adequate volume and pressure. Refer to serial plate for proper gas requirements for your particular model.

ELECTRICAL CONNECTION

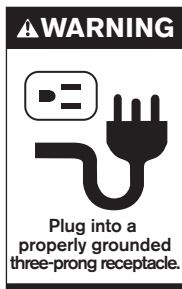

The Keating hot plate with an optional spark ignitor is equipped with a 6' neoprene covered, 3 wire electrical cord with a three-pronged grounded plug for protection against electrical shock. This plug must be placed into a 120V properly grounded three-pronged outlet. For proper grounding procedures see local codes or, in the absence of local codes, the current

National Electrical Code ANSI/NFPA 70 or Canadian Electrical Code CAN 22.1 as applicable.

NOTE: For hot plates with optional spark ignitors, the electrical wiring diagram is located on the front of the control panel. Hot plates with constant pilots do not require any electrical connections.

⚠ WARNING

DO NOT CUT OR REMOVE THE GROUNDING PRONG FROM THIS PLUG.

GAS LEAK TESTING

Prior to lighting your hot plate:

1. Make sure all manual gas valves and gas valves (infinite controls) are in the "OFF" (fully clockwise) position.
2. Turn main ON/OFF manual gas valve to the "ON" position.
3. Have your plumber or gas company check for leaks with a soap solution. (NEVER check with a match!)
4. Have your plumber or gas company representative light the constant pilot. (Not necessary if your hot plate has an optional spark ignitor.)

⚠ WARNING

PROPANE GAS MAY EVENTUALLY LOSE ITS ODOR AND PRECAUTIONS SHOULD BE TAKEN TO ASSURE THAT IT IS NOT PRESENT EVEN THOUGH YOU DO NOT DETECT AN ODOR. IF THERE IS ANY DOUBT, YOU SHOULD CALL YOUR LOCAL PROPANE GAS SUPPLIER FOR ASSISTANCE.

■ OPERATING

LIGHTING

Keating hot plates are designed to provide maximum efficiency and deliver high quality food products. Follow lighting procedure as listed.

⚠ WARNING

OPERATION OF THIS HOT PLATE SHOULD BE LIMITED TO PERSONNEL WHO HAVE BEEN THOROUGHLY TRAINED IN OPERATING PROCEDURES.

1. Open the manual gas valve.
2. For hot plates with constant pilots, light the constant pilot (located between the front and rear burners) with a match. For hot plates with spark ignitors, push in the red knob and rotate it fully counterclockwise until the burner ignites.

⚠ CAUTION

For hot plates with spark ignitors, rotating the red knob without holding it in may damage the gas valve (infinite switch).

⚠ CAUTION

If the pilot or burner fails to stay lit, wait five minutes before attempting to relight to allow any accumulated gas to escape.

3. For hot plates with constant pilots, rotate the red knob counter clockwise to the desired setting. For hot plates with spark ignitors, rotate the red knob clockwise to the desired setting after the burner ignites.

NOTE: The left knob operates the back burner and the right knob operates the front burner.

SHUTDOWN

1. Rotate the red knob fully clockwise for each burner.

CLEANING

When cleaning your hot plate, use Keating Klenzer, the finest dry stainless steel polish available, to restore your hot plate's exterior to its original luster.

⚠ CAUTION

For hot plates with optional spark ignitors, disconnect the electrical power source before doing any cleaning.

WARRANTY REPAIRS

Keating's warranty begins with the date of installation. In the event that your Hot Plate, under warranty, needs repairs other than routine maintenance or cleaning, you are required to contact Keating of Chicago (at 1-800-KEATING) before calling a local service company.

PREVENTIVE MAINTENANCE

Preventive maintenance should be done in daily, weekly, monthly and yearly intervals as necessary. Following preventive maintenance procedures will help keep your hot plate working efficiently. Proper care and servicing will lead to years of quality performance.

PREVENTATIVE MAINTENANCE CHART

| TIME FRAME | OPERATOR/OWNER |
|-------------------------|--|
| AT LEAST DAILY* | <ul style="list-style-type: none"> • Check controls. • Drain and clean drip pan. |
| AT LEAST WEEKLY* | <ul style="list-style-type: none"> • Clean hot plate |
| TIME FRAME | QUALIFIED SERVICE PERSONNEL |
| AT LEAST YEARLY* | <ul style="list-style-type: none"> • Disassemble hot plate to clean burners and orifices. |

*High production facilities should be checked more often. Contact the factory or a local service company to perform maintenance and repairs.

■ SERVICE DIAGNOSIS

■ On constant pilot models, the pilot light will be between 3/8" to 1/2" high and burn clear blue. The constant pilot consumes about 180 BTU/hr. of gas and is used to ignite the burners.

The following diagnosis is only to be used as a guide to qualified service personnel. Keating recommends that you use a qualified & licensed service company. (Equipment still under warranty requires it.) Call 1-800-KEATING if you need assistance in locating a qualified service company.

NOTE: To correctly and quickly diagnose the system, the chart below should be followed in sequential order.

TROUBLE SHOOTING CHART

| PROBLEM | PROBABLE CAUSE | SOLUTION |
|--|---|---|
| Constant pilot won't light | a. Gas isn't turned on. b. Clogged constant pilot orifice. | a. Turn gas valve on. If using flexible connector with quick disconnect, make sure that the quick disconnect is completely engaged. b. Clean the pilot orifice. |
| Delayed ignition | a. Low gas supply or pressure. b. Low pilot flame height. | a. Verify size of incoming gas line to equipment and check gas pressure. b. Adjust pilot flame height. Use a qualified service company. |
| Flames are too high | a. Gas valve (infinite control) set too high. b. Excessive gas supply or pressure. c. Exhaust problems. | a. Turn valve counterclockwise to decrease gas flow. b. Check to see if an inline regulator is present in the main gas line. Have a qualified service person adjust it and check orifices to ensure proper sizes. If an inline regulator is not present, have one installed. c. Contact your HVAC representative. |
| Flames are low or come out of burner air shutter | a. Gas valve (infinite control) set too low. b. Low gas supply or pressure. | a. Turn valve clockwise to increase gas flow. b. Verify size of incoming gas line to equipment and check gas pressure. |

■ ORDERING PARTS

Parts may be ordered by calling 1-800-KEATING or your local Keating service company. We recommend using genuine Keating Replacement Parts - engineered and manufactured specifically to meet exact specifications and requirements for Keating equipment.

Refer to the Keating Hot Plate Limited Warranty for complete service and ordering information.

The model/serial plate is located on the front of the control panel. The serial and model numbers are necessary when ordering.

WARNING AND OPERATING PLATES

All warning and operating plates on the Keating Gas Hot Plate should be in place at all times.

If plates are damaged or lost, replace them immediately.

■ PARTS LIST - GAS HOT PLATE

| ITEM | DESCRIPTION | PART # | MG-2 | MG-4 |
|------|---|--------|--------------------|------|
| | | | Quantity Per Model | |
| 1 | GAS VALVE (INFINITE CONTROL) WITH NG ORIFICE #49 | | | |
| 1 | CONSTANT PILOT | 038323 | 2 | 4 |
| 1 | SPARK IGNITOR | 038323 | 2 | 4 |
| | ORIFICE, HOODED, NATURAL GAS, #49 | 002676 | 2 | 4 |
| | GAS VALVE (INFINITE CONTROL) WITH PROPANE ORIFICE #53 | | | |
| | CONSTANT PILOT | 019097 | 2 | 4 |
| | SPARK IGNITOR | 019098 | 2 | 4 |
| | ORIFICE, HOODED, PROPANE, #53 | 002679 | 2 | 4 |
| 2 | KNOB, RED, GAS VALVE | 032164 | 2 | 4 |
| 3 | CONSTANT PILOT VALVE | 004266 | 1 | 2 |
| 4 | CONSTANT PILOT ASSEMBLY | 004259 | 1 | 2 |
| 5 | CONSTANT PILOT MOUNTING BRACKET | | | |
| | 24" DEEP | 007055 | 1 | 2 |
| | 30" DEEP | 014035 | 1 | 2 |
| 6 | SPARK IGNITOR SWITCH | 038323 | 2 | 4 |
| 7 | SPARK IGNITOR MODULE | 028620 | 1 | 2 |
| 8 | SPARK ELECTRODE WITH WIRE | 013899 | 1 | 2 |
| 9 | SPARK ELECTRODE MOUNTING BRACKET | | | |
| | ABOVE ELECTRODE | 007054 | 1 | 2 |
| | BELOW ELECTRODE, 24" DEEP | 008927 | 1 | 2 |
| | BELOW ELECTRODE, 30" DEEP | 007055 | 1 | 2 |
| 10 | WORK BOX, SPARK IGNITOR MODULE | 008910 | 1 | 2 |
| 11 | BURNER | | | |
| | FRONT, 24" DEEP | 006464 | 1 | 2 |
| | FRONT, 30" DEEP | 002651 | 1 | 2 |
| | REAR, 24" DEEP | 006465 | 1 | 2 |
| | REAR, 30" DEEP | 006466 | 1 | 2 |
| 12 | PRESSURE REGULATOR | | | |
| | NATURAL GAS | 004236 | 1 | 2 |
| | PROPANE | 023527 | 1 | 2 |
| 13 | CORD WITH PLUG, 6', 16/3 SJO FOR SPARK IGNITOR | | | |
| | WITH WIRING HARNESS FOR MG-2 | --- | 1 | |
| | CORD WITH PLUG ONLY | 006315 | 1 | 1 |
| | WIRE HARNESS ONLY | --- | 1 | 2 |
| 14 | CONDUIT, 1/2" (SPECIFY FOR 24" OR 30" DEEP) | --- | 1 | 2 |
| 15 | BUSHING, STRAIN RELIEF | 000470 | 1 | 2 |
| 16 | CONDUIT CONNECTOR, 1/2" | --- | 2 | 4 |
| 17 | BURNER GRATE | 002674 | 2 | 4 |
| 18 | GRATE DIVIDER | | | |
| | MG-2, 24" DEEP | 014601 | 1 | |
| | MG-2, 30" DEEP | 007895 | 1 | |
| | MG-4, 24" DEEP | 014602 | | 1 |
| | MG-4, 30" DEEP | 008933 | | 1 |
| 19 | CONTROL PANEL | | | |
| | MG-2 | | 1 | |
| | MG-4 | | | 1 |
| 20 | DRIP PAN ASSEMBLY | | | |
| | MG-2 24/30, MG-4 24 | 018548 | 1 | 2 |
| | MG-4 30 | 019086 | 1 | 2 |
| 21 | GRATE SEPARATOR, MG-4 | 002663 | | 2 |

HOT PLATE ASSEMBLY

NOTE: MG-4 hot plates are built as two MG-2 hot plates side by side. The MG-2 is shown here.

NOTE: Part numbers correspond with the Hot Plate Parts list on page 7.

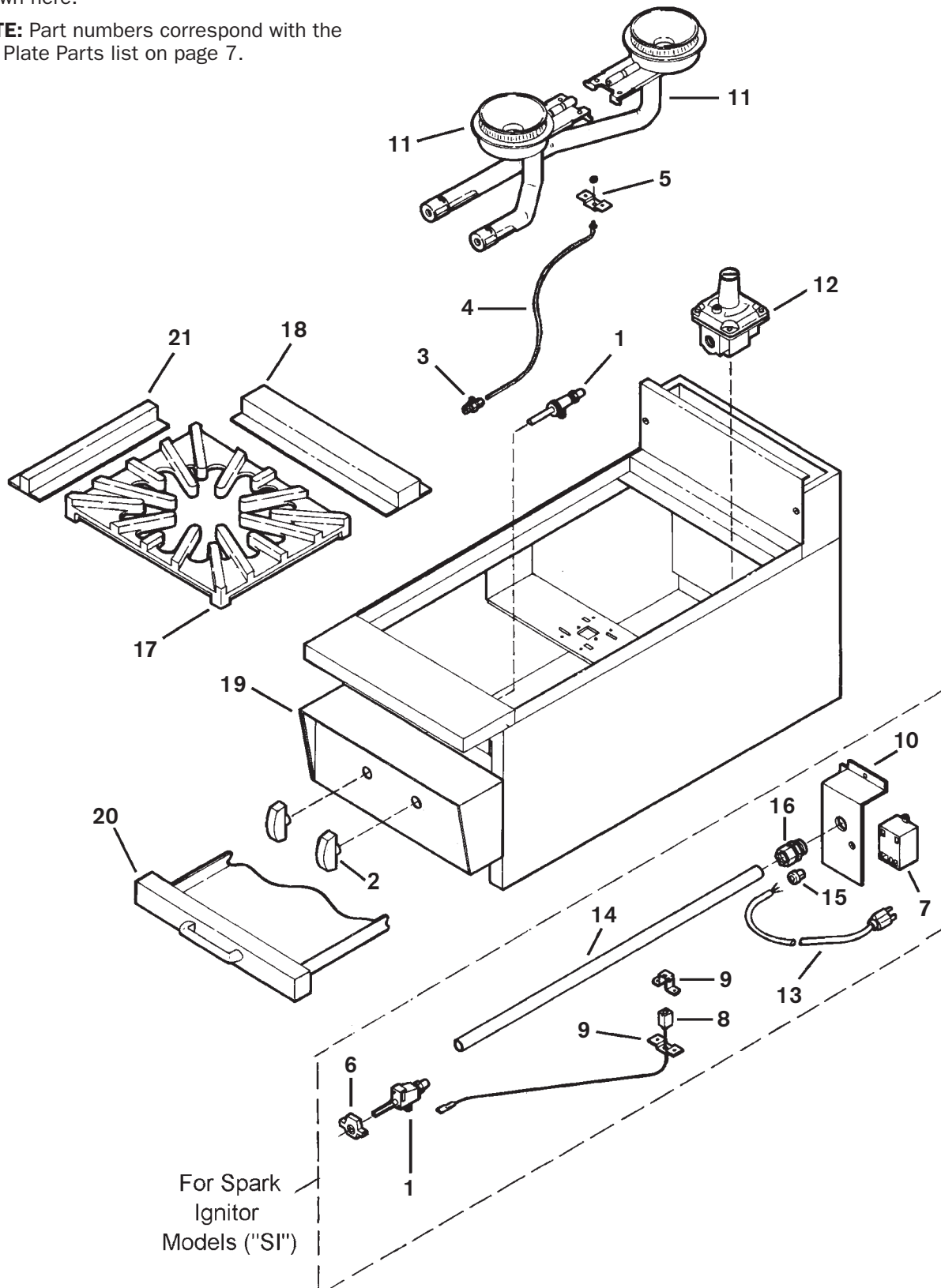

■ WIRING DIAGRAMS

MG SI WIRING AND LADDER DIAGRAMS

The diagrams below apply to hot plates with spark ignition (“SI”). Hot plates with constant pilots (“CP”) do not have any electrical connections.

NOTE: MG-4 hot plates are essentially two MG-2 hot plates side by side. Each cabinet half has its own spark module, electrode and ignitor switches.

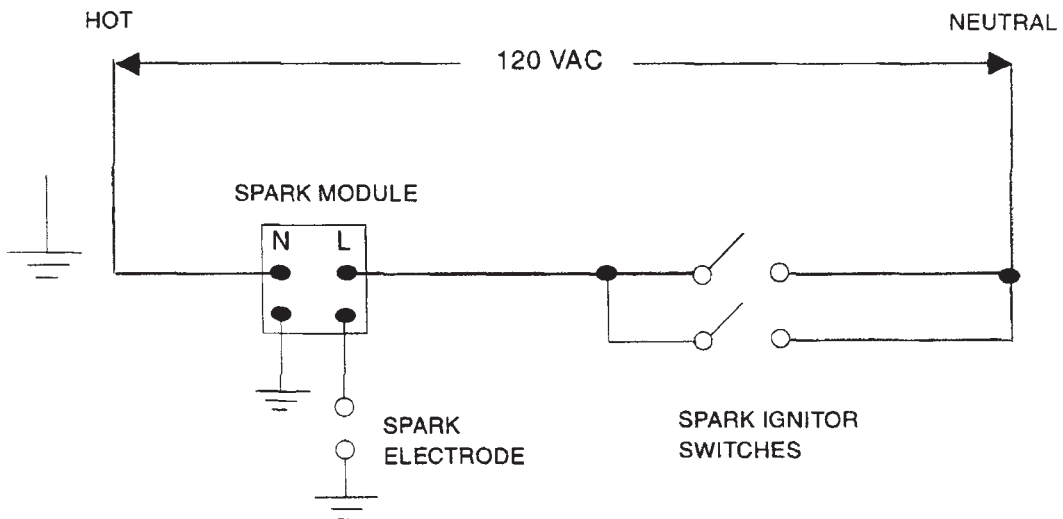
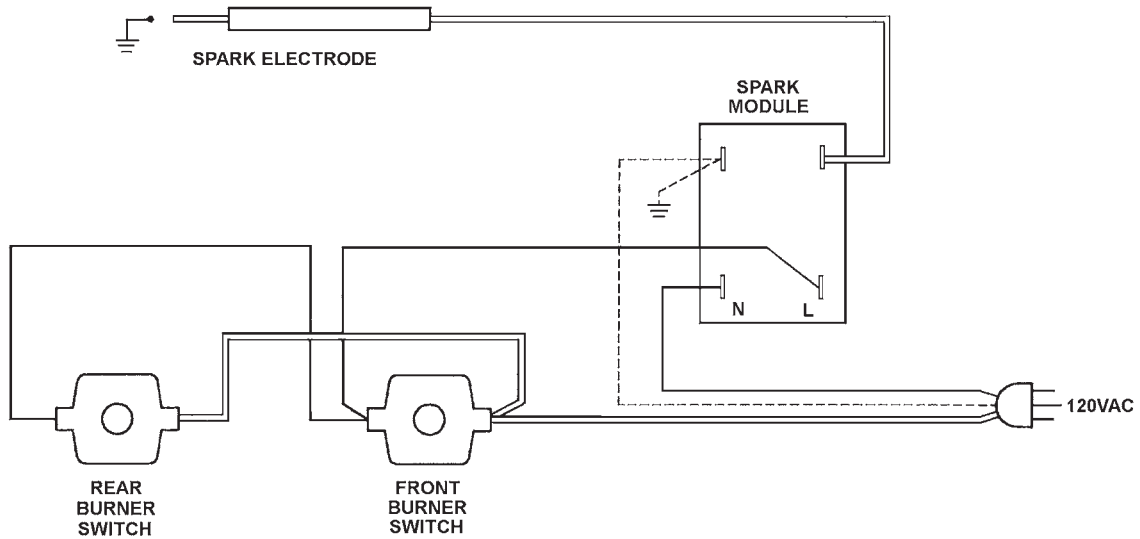



WARRANTY

LIMITED WARRANTY

Keating of Chicago, Inc. ("Keating") warrants to the original purchaser ("Customer"), all new Keating Fryers, Filter Systems, Griddles, Keep Krisp®, Custom Pasta Systems, Top-Side™ Cookers, Computer Timers, Fryer & Pasta Vessels and Keating replacement parts ("products") installed after June 1, 1994 to be free to defects in material or workmanship, subject to the following terms and conditions.

LENGTH OF WARRANTY

All products other than Fryer & Pasta Vessels and replacement parts shall be warranted for a period of one year from the date of original equipment installation. Keating replacement parts are warranted for a period of ninety days from the date of installation. Fryer & Pasta Vessels are warranted as described below.

FRYER & PASTA VESSEL WARRANTY

Fryers purchased after June 1, 1994 carry a prorated vessel warranty on defects in materials or workmanship to the Customer based on the following scale:

| Time from Installation Date | Fryer Vessel Warranty Credit |
|-----------------------------|------------------------------|
| 13-60 months | 100% |
| 61-72 months | 80% |
| 73-84 months | 60% |
| 85-96 months | 40% |
| 97-108 months | 20% |
| 109-120 months | 10% |

The credit for the defective fryer & pasta vessel shall be applied against the cost of the replacement vessel, utilizing Keating's then current price, upon return of the vessel to Keating, (freight to be paid by Keating within the first 12 months only), only during the first 60 months, subject to the limitations described below.

LIMITATIONS OF LIABILITY

In the event of warranty claim or otherwise, the sole obligation of Keating shall be the repair and / or replacement at the option of Keating of the product or component or part thereof. Such repair or replacement shall be at the expense of Keating except that the Customer shall pay the following expenses: all freight and labor expense for Keating replacement parts; for all other products, mileage exceeding 50 miles or travel more than one hour, labor costs of more than one person, overtime rates, truck charges, difference between ground and other mode of transportation, and holiday charges. Any repair or replacement under this Limited Warranty does not constitute an extension of the original warranty for any period for the product or for any component or part thereof. Parts to be replaced under this Limited Warranty will be repaired at the option of Keating with new or functionally operative parts. Keep Krisps and Computer Timers must be returned to Keating for warranty repair or replacement. Field repairs of those items are not authorized.

THE LIABILITY OF KEATING ON ANY CLAIM OF ANY KIND, INCLUDING CLAIMS BASED ON WARRANTY, EXPRESSED OR IMPLIED, CONTRACT, NEGLIGENCE, STRICT LIABILITY OR ANY OTHER THEORIES SHALL BE SOLELY AND EXCLUSIVELY THE REPAIR OR REPLACEMENT OF THE PRODUCT AS STATED HEREIN, AND SUCH LIABILITY SHALL NOT INCLUDE, AND CUSTOMER SPECIFICALLY RENOUNCES ANY RIGHTS TO RECOVER, SPECIAL, INCIDENTAL, CONSEQUENTIAL OR OTHER INJURIES TO PERSONS OR DAMAGE TO PROPERTY, LOSS OF PROFITS OR ANTICIPATED PROFITS, OR LOSS OF USE OF THE PRODUCT.

If any oral statements have been made regarding the Keating products, such statements do not constitute warranties and are not part of the contract sale. This Limited Warranty constitutes the complete, final and exclusive statement with regard to warranties.

THIS LIMITED WARRANTY IS EXCLUSIVE AND IS IN LIEU OF ALL OTHER WARRANTIES WHETHER WRITTEN, ORAL, STATUTORY OR IMPLIED, INCLUDING BUT NOT LIMITED TO ANY WARRANTY OF MERCHANTABILITY OR FITNESS FOR PARTICULAR PURPOSE OR WARRANTY AGAINST LATENT DEFECTS.

EXCLUSIONS

The warranties provided by Keating of Chicago, Inc. do not apply in the following instances:

- Defects arising out of or resulting from improper installation or maintenance, abuse, misuse, modification or alteration by unauthorized service personnel, or any other condition not attributable to a defect in material or workmanship. Proper installation and maintenance are the responsibility of the installer and Customer, respectively. Proper installation and maintenance procedures are prescribed by the Keating Service Manual.
- In the event that the product was damaged after leaving the factory due to flood, fire, other acts of God or accident, damage during shipment should be reported to the carrier and is not the responsibility of Keating.
- In the event the serial number or rating plate has been removed from the product or altered.
- On parts which would normally be worn or replaced under normal conditions, including but not limited to electric bulbs, fuses, interior and exterior finishes, gaskets and radiants.
- With regard to adjustments and calibrations such as leveling, tightening of fasteners or plumbing connections, improper gas pressure or improper electrical supply, the checking of and changes in adjustment and calibrations are the responsibility of the installer. Proper installation procedures are prescribed by the Keating Service Manual.
- In the event of unauthorized repairs or alterations to the Keating product.
- With the use of sodium chloride in pasta vessels or harsh chemicals in fryer or pasta vessels.
- Installation in Household.

OTHER TERMS AND CONDITIONS

The Customer must provide proof of purchase from Keating.

This Limited Warranty is valid in the 50 United States, its territories, and Canada, and is void elsewhere.

Keating products are sold for commercial use only. If any Keating product is sold as a component of another product or used as a consumer product, such Keating product is sold As Is without any warranty.

If any provision of this Limited Warranty is held to be unenforceable under the law of any jurisdiction, such provision shall be inapplicable in such jurisdiction, and the remainder of the warranty shall remain unaffected. Further in such event, the maximum exclusion or limitation allowable under applicable law shall be deemed substituted for the unenforceable provision.

This Limited Warranty shall be governed by and construed in accordance with the laws of the State of Illinois.

TO SECURE WARRANTY SERVICE

All repair services under this Limited Warranty must be authorized by Keating or performed at Keating. Authorization may be obtained by calling 1-800-KEATING within the Continental United States, Alaska, Hawaii, Puerto Rico and Canada during normal business hours (8 a.m. through 5 p.m. Central Time, Monday through Friday). When calling, please have the following information available: (1) name, address and telephone number of the Customer; (2) location of product, if different; (3) name, model number and serial number of the product; (4) installation date; and (5) description of defect. Keating will then issue a service authorization work order number to one of its approved independent servicing organizations, or request the product or part be shipped to Keating for repair or replacement, as appropriate. Any defective part subject to a claim under this Limited Warranty must be shipped freight prepaid to Keating for testing and examination. Keating's decision as to the cause and nature of any defect under this Limited Warranty shall be final.

■ **SERVICE INFORMATION:**

If you have a service related question call **1-800-KEATING**.
Please state the nature of the call; it will ensure speaking with the appropriate person.

Have your serial and model number available when ordering parts.

As continuous product improvement occurs, specifications may be changed without notice.

.....
KEATING LIMITED WARRANTY CARD

PLEASE COMPLETE AND MAIL AT ONCE--WARRANTY IS NOT IN EFFECT UNTIL CARD IS RETURNED, OR COMPLETE THE WARRANTY CARD ON OUR WEBSITE FOR YOUR CONVENIENCE.

COMPANY: _____

ADDRESS: _____

CITY: _____ STATE: _____ ZIP CODE: _____

DEALER NAME: _____

DATE OF PURCHASE: _____ INVOICE #: _____

SERIAL #: _____ MODEL: _____

FRYER GRIDDLE CUSTOM PASTA
 FILTER SYSTEM TOP-SIDE COOKER HOTPLATE

I HAVE READ THE INSTALLATION AND OPERATING INSTRUCTIONS.

SIGNED: _____ DATE: _____



KEATING OF CHICAGO, INC.
8901 West 50th Street
McCook, IL 60525-6001

1-800-KEATING
PHONE: 708-246-3000
FAX: 708-246-3100

Serving Those Who Serve the Very Best®