



SPICER[®]
Off-Highway Products

Service Manual

Gear Box
314

GSM-0006E
January 2015

CONTENTS

INTRODUCTION	5
SPECIFICATIONS	7
DATA PLATE	7
CONVERSION TABLES	8
TORQUE SPECIFICATIONS	9
COARSE PITCH	9
FINE PITCH	9
MAINTENANCE	11
MAINTENANCE POINTS	11
MAINTENANCE INTERVALS	12
LUBRICANT & SEALANT SPECIFICATIONS	13
SAFETY PRECAUTIONS	15
DIRECTLY FLANGED REDUCTION GEAR	17
EXPLODED VIEW	17
DISASSEMBLY	18
ASSEMBLY	22
INTEGRATED REDUCTION GEAR	27
EXPLODED VIEW	27
DISASSEMBLY	28
ASSEMBLY	31

INTRODUCTION

The efficiency and continued operation of mechanical units depend on constant, correct maintenance and also on efficient repair work, should there be a break-down or malfunction. The instructions contained in this manual have been based on a complete overhaul of the unit. However, it is up to the mechanic to decide whether or not it is necessary to assemble only individual components, when partial repair work is needed. The manual provides a quick and sure guide which, with the use of photographs and diagrams illustrating the various phases of the operations, allows accurate work to be performed. All the information needed for correct disassembly, checks and assembly of each individual component is set out below. In order to remove the differential unit from the vehicle, the manuals provided by the vehicle manufacturer should be consulted. In describing the following operations it is presumed that the unit has already been removed from the vehicle.

IMPORTANT: In order to facilitate work and protect both working surfaces and operators, it is advisable to use proper equipment such as: trestles or supporting benches, plastic or copper hammers, appropriate levers, pullers and specific spanners or wrenches. Before going on to disassemble the parts and drain the oil, it is best to thoroughly clean the unit, removing any encrusted or accumulated grease.

INTRODUCTORY REMARKS: All the disassembled mechanical units should be thoroughly cleaned with appropriate products and restored or replaced if damage, wear, cracking or seizing have occurred. In particular, thoroughly check the condition of all moving parts (bearings, gears, crown wheel and pinion, shafts) and sealing parts (O-rings, oil shields) which are subject to major stress and wear. In any case, it is advisable to replace the seals every time a component is overhauled or repaired. During assembly, the sealing rings must be lubricated on the sealing edge. In the case of the crown wheel and pinion, replacement of one component requires the replacement of the other one. During assembly, the prescribed pre-loading, backlash and torque of parts must be maintained.

SPECIFIC EQUIPMENT AND SPARE PARTS: The drawings of all specific tools required for maintenance and repair work can be found at the end of this manual ; spare parts may be ordered either from the vehicle manufacturer or directly from the Service Centers or Authorized Distributors of Dana Holding.

SPECIFICATIONS

DATA PLATE

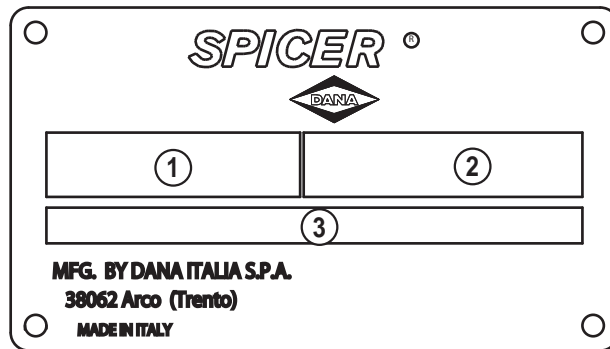

- 1 - Model number
- 2 - Serial number
- 3 - Lubricant

CONVERSION TABLES

CONVERSION TABLES

UNITS OF PRESSURE

	Atm	Bar	MPa	Pa	PSI
Atm	1	1	0,1	10^5	14,4
Bar	1	1	0,1	10^5	14,4
MPa	10	10	1	10^6	144
Pa	0,00001	0,00001	10^{-6}	1	-
PSI	-	-	-	-	1

UNIT OF WEIGHT

	N	daN	kN	kg	lbs
1N	1	0,1	0,001	0,102	0,225
1daN	10	1	0,01	1,02	2,25
1kN	1000	100	1	102	225
1kg	9,81	0,981	0,00981	1	2,205

UNITS OF TORQUE

	N·m	daN·m	kN·m	kg·m	lb·in
1N·m	1	0,1	0,001	0,102	8,854
1daN·m	10	1	0,01	1,02	88,54
1kN·m	1000	100	1	102	8854
1kg·m	9,81	0,981	0,00981	1	86,8
1 lb·in	0,1129	0,01129	0,0001129	0,01152	1

TORQUE SPECIFICATIONS

TORQUE SPECIFICATIONS

COARSE PITCH

SIZE OF BOLT	TYPE OF BOLT					
	8.8	8.8 + Loctite 270	10.9	10.9 + Loctite 270	12.9	12.9 + Loctite 270
M6 x 1 mm	9,5 – 10,5 N·m	10,5 – 11,5 N·m	14,3 – 15,7 N·m	15,2 – 16,8 N·m	16,2 – 17,8 N·m	18,1 – 20 N·m
M8 x 1,25 mm	23,8 – 26,2 N·m	25,6 – 28,4 N·m	34,2 – 37,8 N·m	36,7 – 40,5 N·m	39 – 43 N·m	43,7 – 48,3 N·m
M10 x 1,5 mm	48 – 53 N·m	52 – 58 N·m	68 – 75 N·m	73 – 81 N·m	80 – 88 N·m	88 – 97 N·m
M12 x 1,75 mm	82 – 91 N·m	90 – 100 N·m	116 – 128 N·m	126 – 139 N·m	139 – 153 N·m	152 – 168 N·m
M14 x 2 mm	129 – 143 N·m	143 – 158 N·m	182 – 202 N·m	200 – 221 N·m	221 – 244 N·m	238 – 263 N·m
M16 x 2 mm	200 – 221 N·m	219 – 242 N·m	283 – 312 N·m	309 – 341 N·m	337 – 373 N·m	371 – 410 N·m
M18 x 2,5 mm	276 – 305 N·m	299 – 331 N·m	390 – 431 N·m	428 – 473 N·m	466 – 515 N·m	509 – 562 N·m
M20 x 2,5 mm	390 – 431 N·m	428 – 473 N·m	553 – 611 N·m	603 – 667 N·m	660 – 730 N·m	722 – 798 N·m
M22 x 2,5 mm	523 – 578 N·m	575 – 635 N·m	746 – 824 N·m	817 – 903 N·m	893 – 987 N·m	974 – 1076 N·m
M24 x 3 mm	675 – 746 N·m	732 – 809 N·m	950 – 1050 N·m	1040 – 1150 N·m	1140 – 1260 N·m	1240 – 1370 N·m
M27 x 3 mm	998 – 1103 N·m	1088 – 1202 N·m	1411 – 1559 N·m	1539 – 1701 N·m	1710 – 1890 N·m	1838 – 2032 N·m
M30 x 3,5 mm	1378 – 1523 N·m	1473 – 1628 N·m	1914 – 2115 N·m	2085 – 2305 N·m	2280 – 2520 N·m	2494 – 2757 N·m

FINE PITCH

SIZE OF BOLT	TYPE OF BOLT					
	8.8	8.8 + Loctite 270	10.9	10.9 + Loctite 270	12.9	12.9 + Loctite 270
M8 x 1 mm	25,7 – 28,3 N·m	27,5 – 30,5 N·m	36,2 – 39,8 N·m	40 – 44 N·m	42,8 – 47,2 N·m	47,5 – 52,5 N·m
M10 x 1,25 mm	49,4 – 54,6 N·m	55,2 – 61 N·m	71,5 – 78,5 N·m	78 – 86 N·m	86 – 94 N·m	93 – 103 N·m
M12 x 1,25 mm	90 – 100 N·m	98 – 109 N·m	128 – 142 N·m	139 – 154 N·m	152 – 168 N·m	166 – 184 N·m
M12 x 1,5 mm	86 – 95 N·m	94 – 104 N·m	120 – 132 N·m	133 – 147 N·m	143 – 158 N·m	159 – 175 N·m
M14 x 1,5 mm	143 – 158 N·m	157 – 173 N·m	200 – 222 N·m	219 – 242 N·m	238 – 263 N·m	261 – 289 N·m
M16 x 1,5 mm	214 – 236 N·m	233 – 257 N·m	302 – 334 N·m	333 – 368 N·m	361 – 399 N·m	394 – 436 N·m
M18 x 1,5 mm	312 – 345 N·m	342 – 378 N·m	442 – 489 N·m	485 – 536 N·m	527 – 583 N·m	580 – 641 N·m
M20 x 1,5 mm	437 – 483 N·m	475 – 525 N·m	613 – 677 N·m	674 – 745 N·m	736 – 814 N·m	808 – 893 N·m
M22 x 1,5 mm	581 – 642 N·m	637 – 704 N·m	822 – 908 N·m	903 – 998 N·m	998 – 1103 N·m	1078 – 1191 N·m
M24 x 2 mm	741 – 819 N·m	808 – 893 N·m	1045 – 1155 N·m	1140 – 1260 N·m	1235 – 1365 N·m	1363 – 1507 N·m
M27 x 2 mm	1083 – 1197 N·m	1178 – 1302 N·m	1520 – 1680 N·m	1672 – 1848 N·m	1834 – 2027 N·m	2000 – 2210 N·m
M30 x 2 mm	1511 – 1670 N·m	1648 – 1822 N·m	2138 – 2363 N·m	2332 – 2577 N·m	2565 – 2835 N·m	2788 – 3082 N·m

MAINTENANCE

MAINTENANCE POINTS

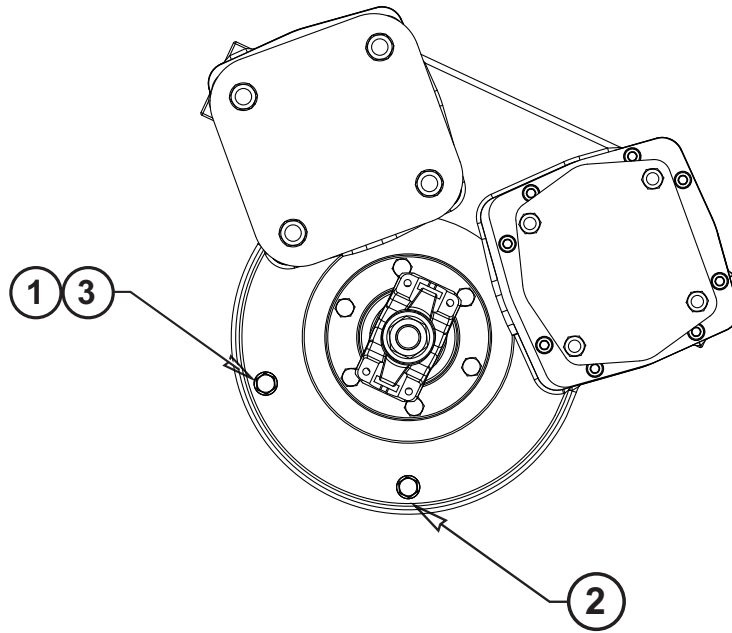

- 1 - Oil fill plug
- 2 - Oil drain plug
- 3 - Check level plug

MAINTENANCE INTERVALS

MAINTENANCE INTERVALS

OPERATION	COMPARTMENT	1ST CHANGE / CHECK (whs)	FREQUENCY (whs)	LUBRICANTS	REMARKS
Oil level check	All	10 whs	Monthly	For details see below	Clean carefully oil plug magnet
	Differential	100 - 250 whs max. *	1000 whs	Central body standard bevel gears - UTTO (API GL4), or gear: J20/C, MF M1143, or gear: SAE80W/90 (API GL4 or GL5)	If with limited slip differential, and/or wet brakes, use LS additivated oils. Clean carefully oil plug magnet.
Hub Reduction	Dropbox (if any)	100 - 250 whs max. *		Central body hypoid bevel gears - SAE80W/90 (API GL5)	Clean carefully oil plug magnet.
			UTTO (API GL4) J20/C; or gear: SAE80W/90 (API GL4 or GL5)		
Adjustment	Negative brake (SAHR)	100 whs	Every 500 whs	Gears with wet discs clutch - ATF GM Dexron IIE, Dexron III	Clean carefully oil plug magnet. * In accordance with Machine Service requirements
	Service brake			Only gears - UTTO J20/C, or gear: SAE80W/90 (API GL4 or GL5)	
Tightening	Wheel nuts	10 whs	Every 200 whs	No lubricant allowed	Check for any damage or corrosion of treads or mating surfaces
	King Pin Tapered Bearings	10 whs	Normal work – Weekly or Severe duty – Daily	For hydraulic actuations (brakes, SAHR, 100% diff. lock, etc.) use ATF oil e.g. GM Dexron IIE, Dexron III	Not applicable
Seals	10 whs	No lubricant allowed		DOT brake fluids oils are NOT compatible w/std oils	Check for any damage or corrosion of treads or mating surfaces
Greasing	King Pin Bushings	10 whs		NLG12 EP or NLG13 EP	Supply grease until clean grease is visible from outside.
	Trunnion Bushings	10 whs		NLG12 EP or NLG13 EP with Moly Additive	Grease performance level acc. to: According to DIN 51825 level KP2K-30 (NLG12) or KP3K-20 (NLG13); ASTM D4950 NLG12 GC-LB

In case of severe duty, half oil change intervals must be applied.
 In case of extreme environments, chatter noise, reduce oil change intervals accordingly.
 In case of extremely low ambient temperatures (<-20°C), use appropriate oils w/low viscosity: UTTO J20/D (std Bevel Gears), SAE 75W/90 API GL5 LS (Hypoid Bevel Gears: models 192, 193, 194),
 API GL5: Acc. To MIL L-2105-B
 See PSB 00279 (latest update) for more info regarding lubricants and viscosity grades.

LUBRICANT & SEALANT SPECIFICATIONS

1 - Locking, sealing and lubricating materials referred to in this manual are the same used in the shop-floor.

2 - The table below gives an account of the typical applications of each single material, in order to facilitate replacement with similar products marketed by different brand names with different trade marks.

LOCTITE 242

Anaerobic product apt to prevent the loosening of screws, nuts and plugs. Used for medium-strength locking. Before using it, completely remove any lubricant by using the specific activator.

LOCTITE 243

The oleocompatible alternative to 242. Does not require the activation of lubricated surfaces.

LOCTITE 270

Anaerobic product for very-high strength locking of screws and nuts. Before using it, completely remove any lubricant by using the specific activator.

To remove parts, it may be necessary to heat them at 80°C approximately.

LOCTITE 275

Anaerobic product suitable for high-strength locking and sealing of large threaded parts, bolts and stud bolts, for pipe sealing and for protecting parts against tampering; suitable for sealing coupling surfaces with a maximum diametrical clearance of 0.25 mm.

LOCTITE 510

Anaerobic product for the hermetic sealing of flanged units and screw holes communicating with fluids. Can seal clearances between flanges up to 0.2 mm.

LOCTITE 577

Quick anaerobic sealant for sealing threaded portions of conical or cylindrical unions up to M80. Before using it, remove any lubricant with the specific activator. After polymerisation, disassembly may result rather difficult, so heating may be necessary for larger diameters.

LOCTITE 638

Anaerobic adhesive for fast and high-strength gluing of cylindrical metal joints (hub on shaft). Can glue together parts with clearance ranging between 0.1 and 0.25 mm.

LOCTITE 648

Anaerobic adhesive for fast and medium-strength gluing of cylindrical metal joints (hub on shaft). Can glue together parts with radial clearance below 0.1 mm.

AREXONS (REPOSITIONABLE JOINTING COMPOUND FOR SEALS)

Solvent-based sealing compound for elastic seals, drying through evaporation. Used for sealing the outer diameter of sealing rings for rotating shafts with outer metal reinforcement.

SILICONE

Semi-fluid adhesive material used for sealing and filling and to protect components from environmental and physical elements. Polymerises with non-corrosive dampness.

TECNO LUBE/101 (SILICONE-BASED GREASE)

Highly adhesive synthetic grease, with silicone compounds added.

Applied to adjustment screws with hole communicating with oil-type fluids.

Used when frequent adjusting is required.

MOLIKOTE (DOW CORNING)





Lubricating compound containing molybdenum disulphide, used to lubricate articulation pins and to prevent sticking and oxidation of parts that are not lubricated on a regular basis.

(LITHIUM-BASED) GREASE

Applied to bearings, sliding parts and used to lubricate seals or parts during assembly.

SAFETY PRECAUTIONS

1. During all operations described in this manual, the axle should be fastened onto a trestle, while the other parts mentioned should rest on supporting benches.
2. When removing one of the arms, an anti-tilting safety trestle should be placed under the other arm.
3. When working on an arm that is fitted on the machine, make sure that the supporting trestles are correctly positioned and that the machine is locked lengthways.
4. Do not admit any other person inside the work area; mark off the area, hang warning signs and remove the ignition key from the machine.
5. Use only clean, quality tools; discard all worn, damaged, lowquality or improvised wrenches and tools. Ensure that all torque wrenches have been checked and calibrated.
6. Always wear gloves and non-slip rubber shoes when performing repair work.
7. Should you stain a surface with oil, remove marks straight away.
8. Dispose of all lubricants, seals, rags and solvents once work has been completed. Treat them as special waste and dispose of them according to the relative law provisions obtaining in the country where the axles are being overhauled.
9. Make sure that only weak solvents are used for cleaning purposes; avoid using turpentine, dilutants and toluol, xylolbased or similar solvents; use light solvents such as Kerosene, mineral spirits or water-based, environment friendly solvents.
10. For the sake of clarity, the parts that do not normally need to be removed have not been reproduced in some of the diagrams.
11. For agricultural axles, the terms RIGHT and LEFT refer to the position from the operator's seat. For construction axles, the terms RIGHT and LEFT refer to the position outside facing the machine (with the input drive facing forward)
12. After repair work has been completed, accurately touch up any coated part that may have been damaged.
13. Follow all safety instructions in the Original Equipment Manufacturer (OEM) manual that came with the vehicle.

 DANGER	Indicates an imminently hazardous situation which, if not avoided, will result in death or serious injury.
 WARNING	Indicates an imminently hazardous situation which, if not avoided, could result in death or serious injury.
 CAUTION	Indicates a situation which, if not avoided, may result in damage to components.
 NOTICE	Indicates information which may make product service easier to perform.

DIRECTLY FLANGED REDUCTION GEAR

EXPLODED VIEW

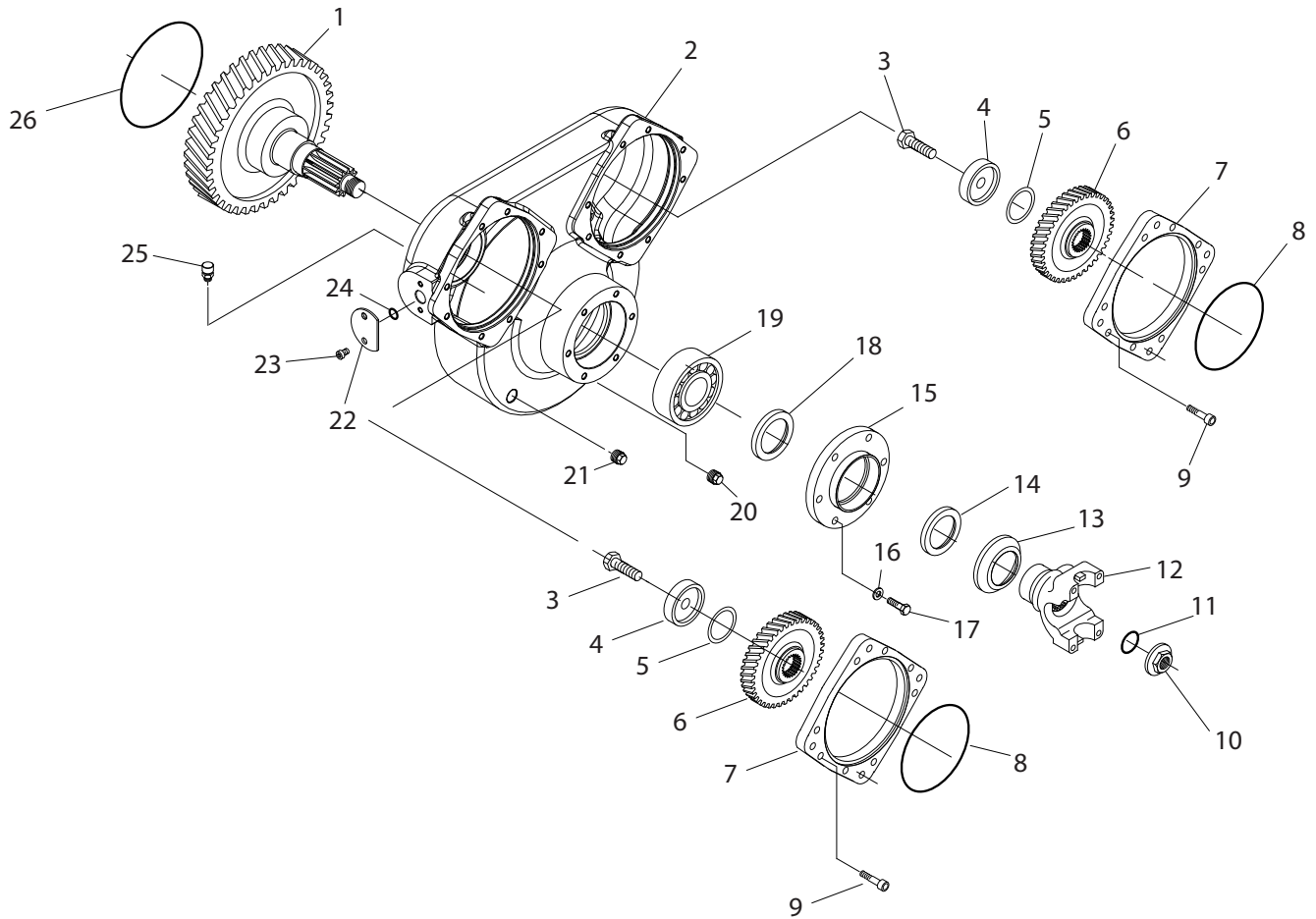

DISASSEMBLY

DISASSEMBLY

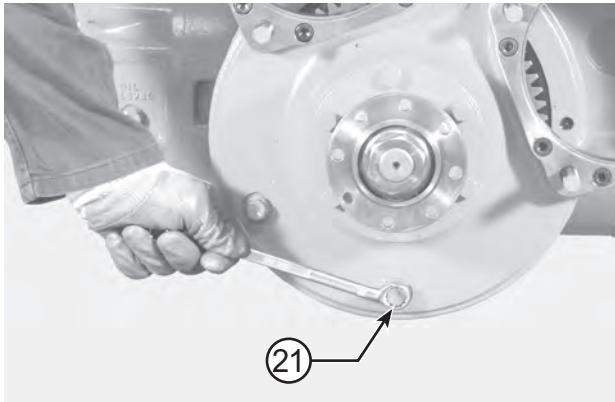

FIGURE 1: Remove the oil drain plug (21) and drain oil.

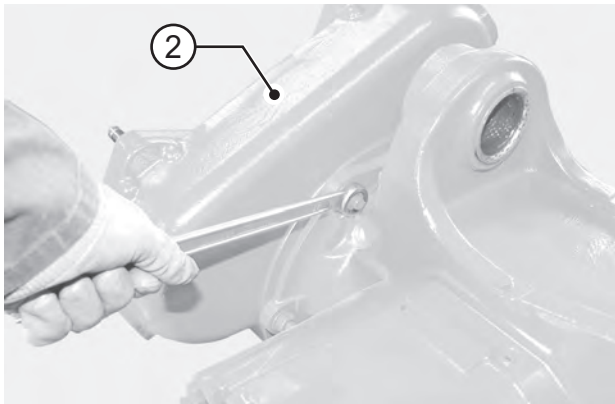

FIGURE 2: DIRECTLY FLANGED VERSION ONLY
Remove screws attaching the reduction unit (2).



FIGURE 3: DIRECTLY FLANGED VERSION ONLY
Mark the housing position before removing.

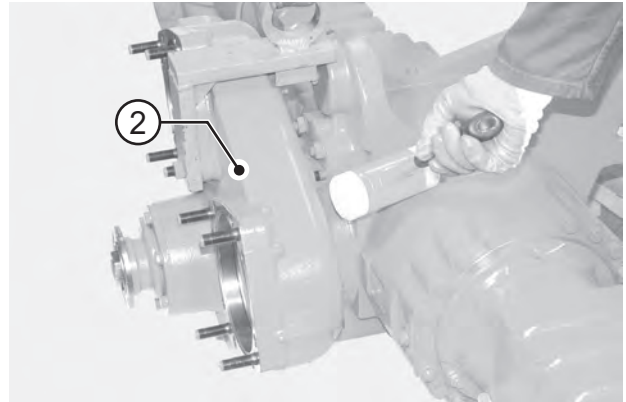

FIGURE 4: DIRECTLY FLANGED VERSION ONLY
Loosen the reduction unit using a plastic hammer.



FIGURE 5: DIRECTLY FLANGED VERSION ONLY
Disjoin the entire reduction unit (2) from the axle and place it on a bench.

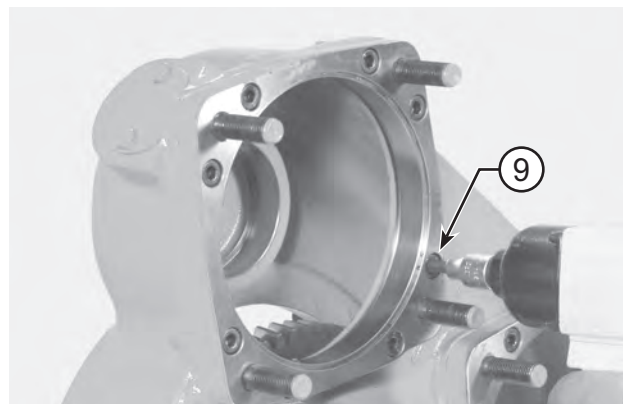

FIGURE 6: Remove screws (9) from the motion input cover.

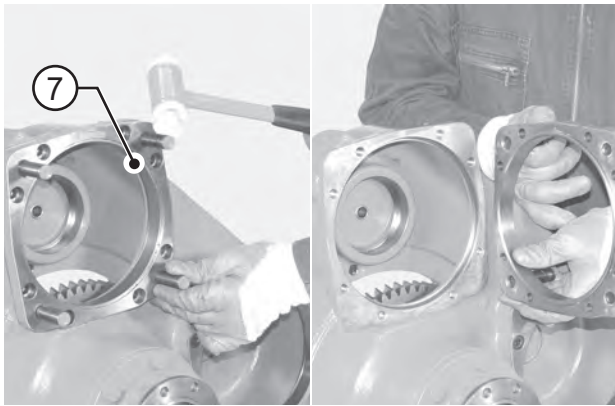

FIGURE 7: Disjoin both motion entrance covers (7).

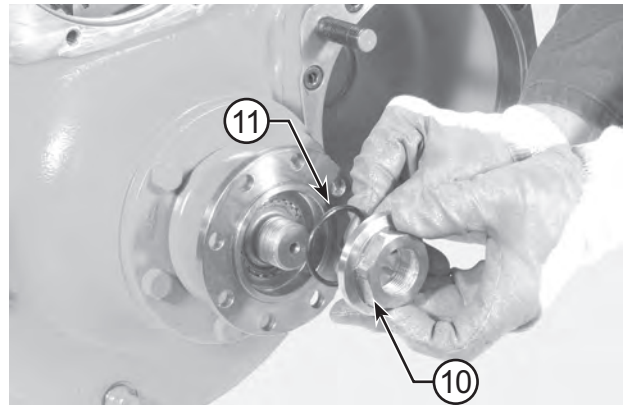

FIGURE 10: Remove the nut (10) and o-ring (11).

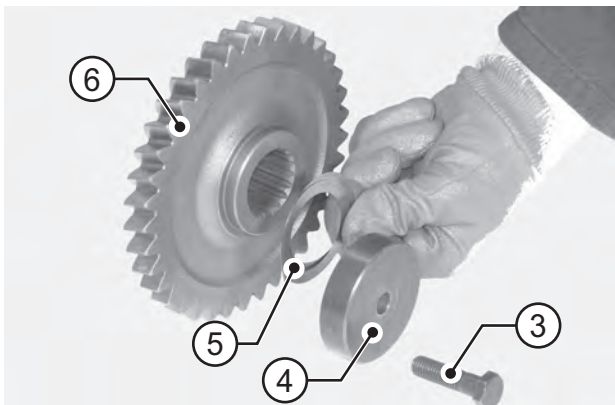

FIGURE 8: Remove the motion entrance cover components (3, 4, 5, 6).

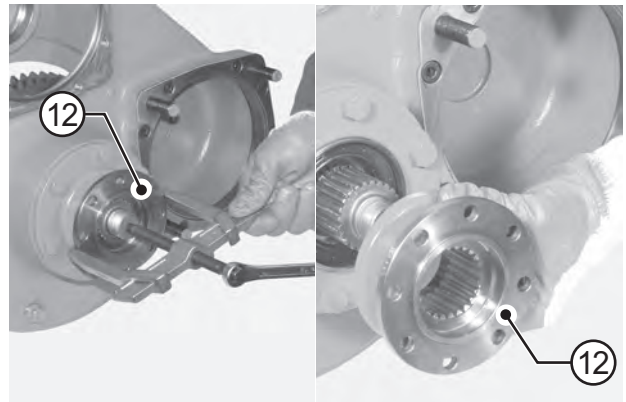

FIGURE 11: Remove the flange (12).

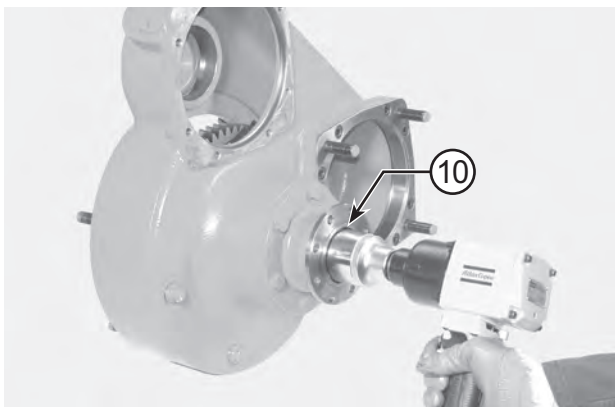

FIGURE 9: Loosen the flange (12) nut (10).

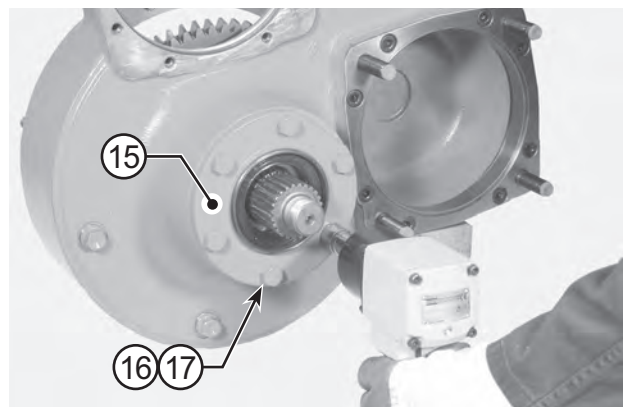

FIGURE 12: Loosen and remove the cover (15) screws (17) and washers (16).

NOTE:

Write down that washers (16) are only fitted where cover top is rough.

DISASSEMBLY

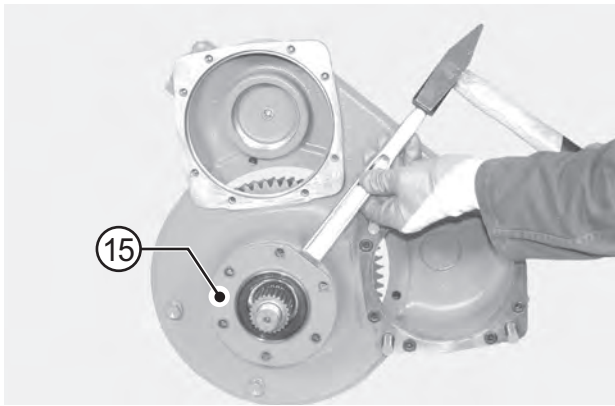

FIGURE 13: Using a driver, loosen the cover (15).

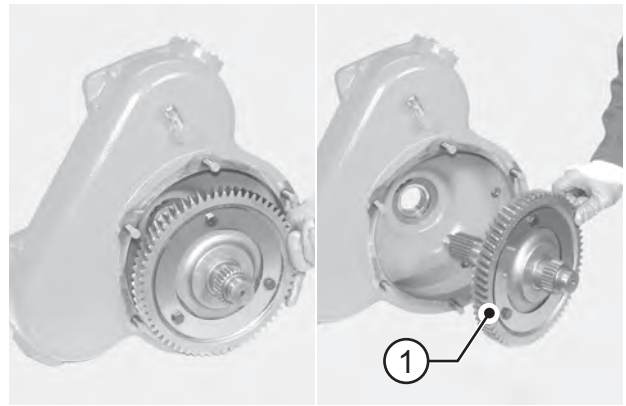

FIGURE 16: Remove the complete input shaft assembly (1).



FIGURE 14: Remove the cover sealing ring (14).

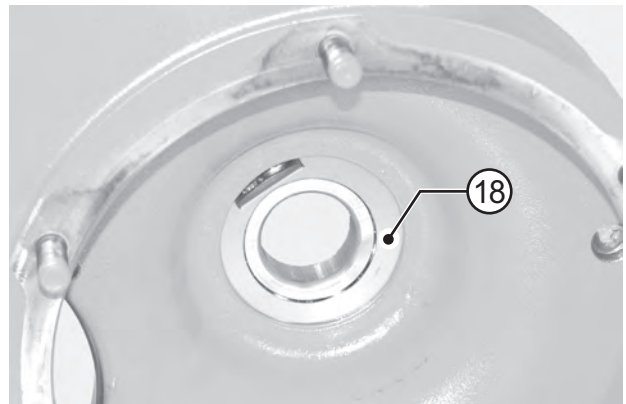

FIGURE 17: Only if necessary to repair, mark the oil shield plate (18) position before removing.

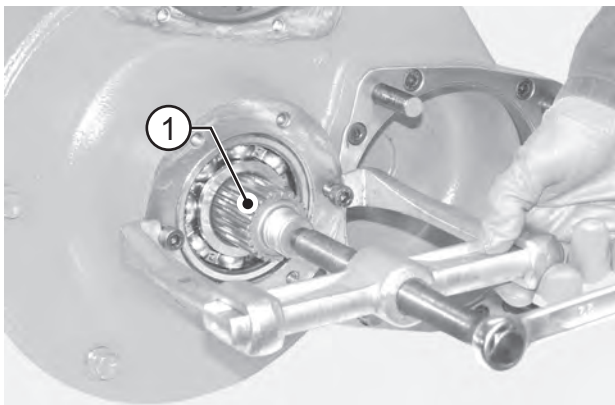

FIGURE 15: Using a puller, remove the lower shaft (1).

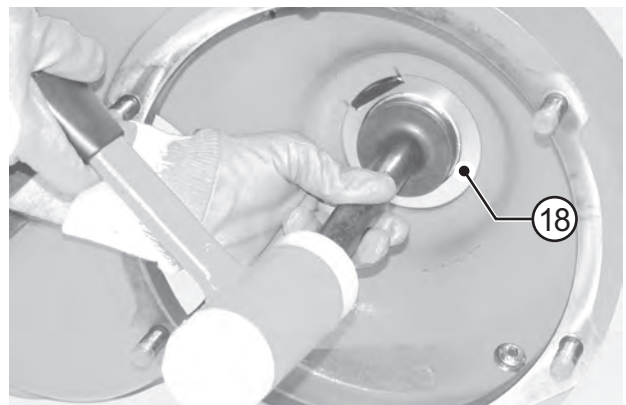

FIGURE 18: Using a plastic hammer and driver, loosen the bearing (19) and the oil shield plate (18) only if necessary.

⚠ CAUTION

The oil inlet must face upwards.

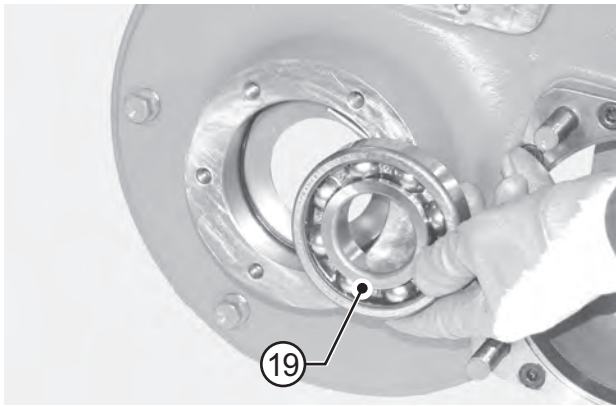

FIGURE 19: Remove the bearing (19).

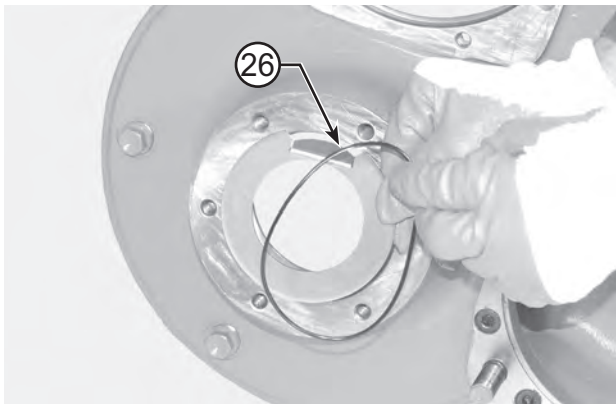

FIGURE 20: Replace the o-ring (26).

ASSEMBLY

ASSEMBLY

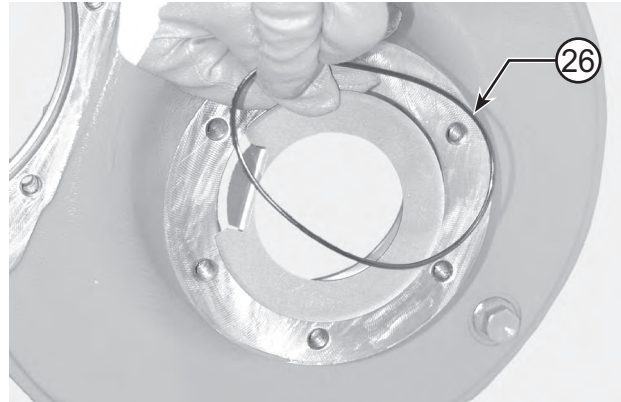
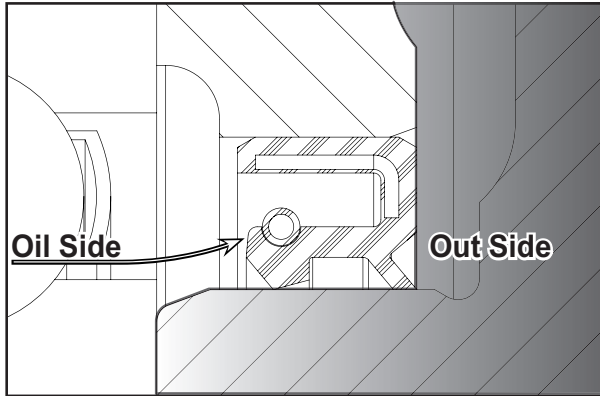

FIGURE 23: Install the oil shield plate (18) and o-ring (26) with oil inlet facing upwards.

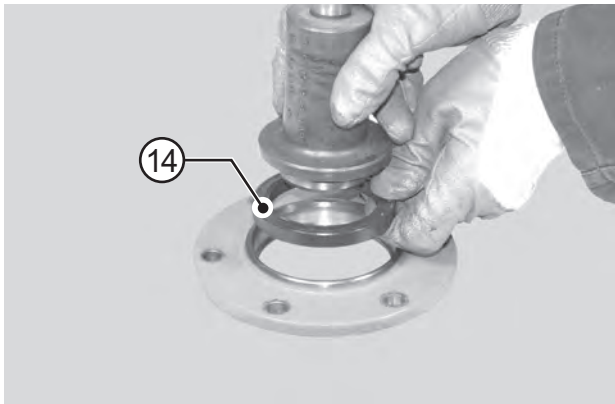

FIGURE 21: Lubricate and fit the sealing ring (14) into the cover.



FIGURE 24: Verify the oil shield plate (18) position marked during disassembly.

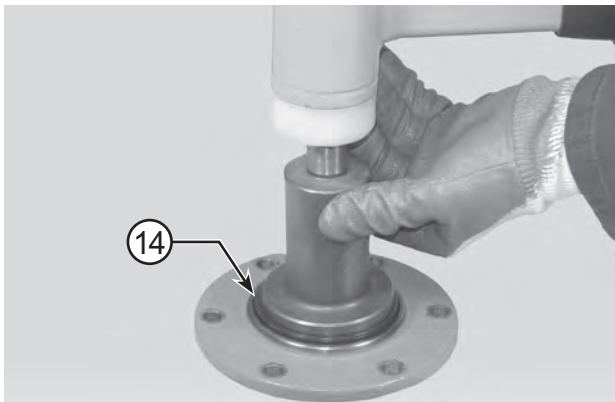

FIGURE 22: Pay particular attention to sealing ring (14) direction.

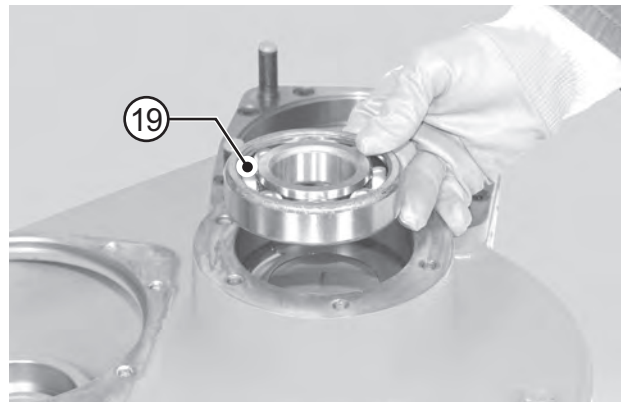

FIGURE 25: Install the bearing (19).

NOTE:

Move the bearing to the limit stop by hammering lightly all around the edge.

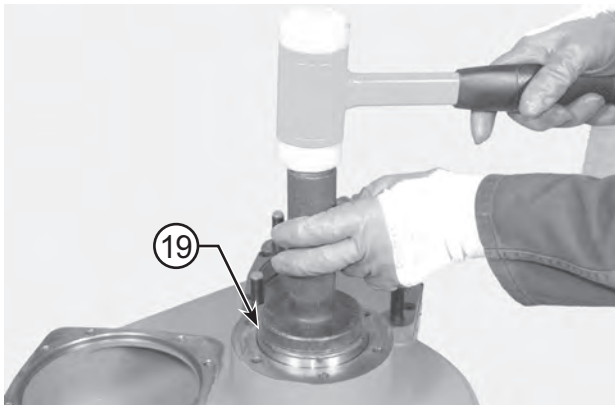

FIGURE 26: Seat using a bearing driver.

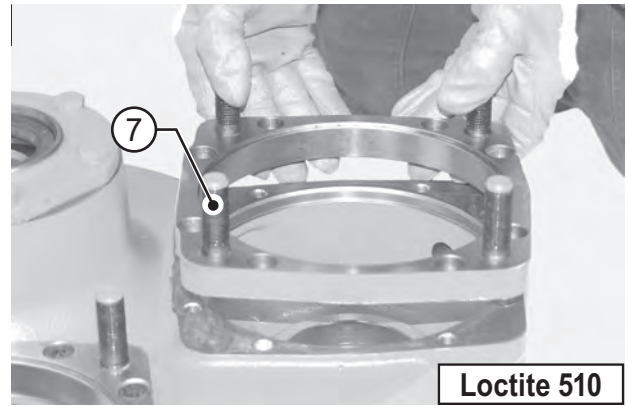

FIGURE 29: Assemble the cover (7), spreading Loctite 510 on surfaces and screws (9).

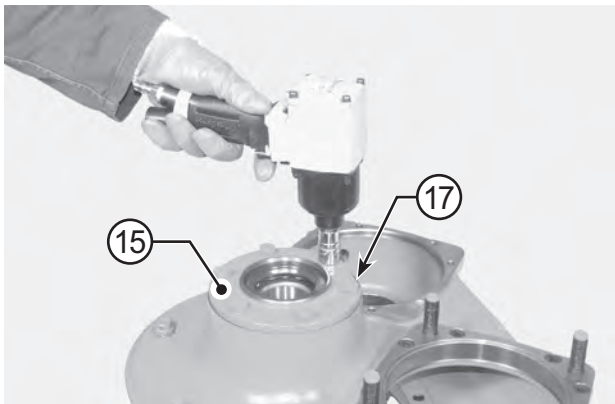

FIGURE 27: Assemble the cover (15) with screws (17) spreading Loctite 510 on surfaces.

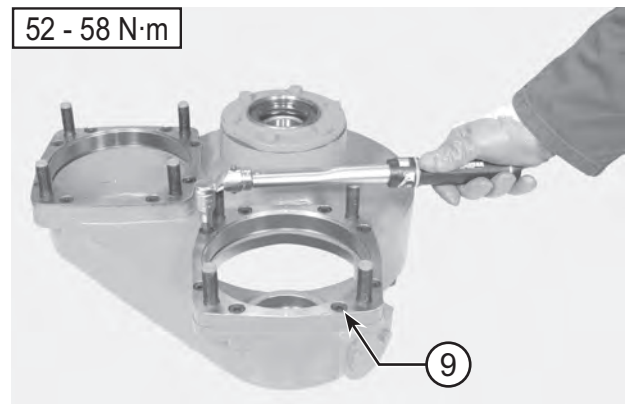

FIGURE 30: Tighten screws (9) using a torque wrench setting of 52 - 58 N·m.

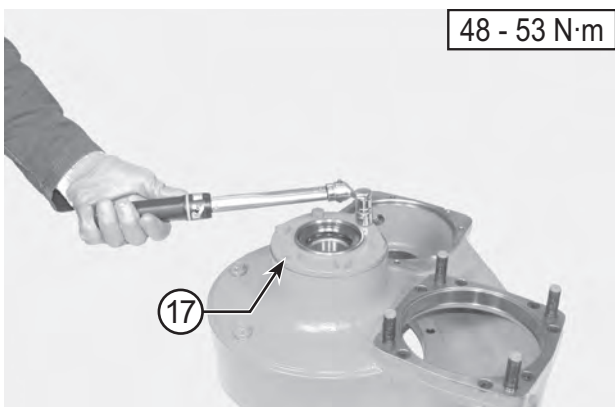

FIGURE 28: Tighten screws (17) using a torque wrench setting of 48 - 53 N·m.



FIGURE 31: Heat the inner bearing (19) to about 100 C°.

ASSEMBLY

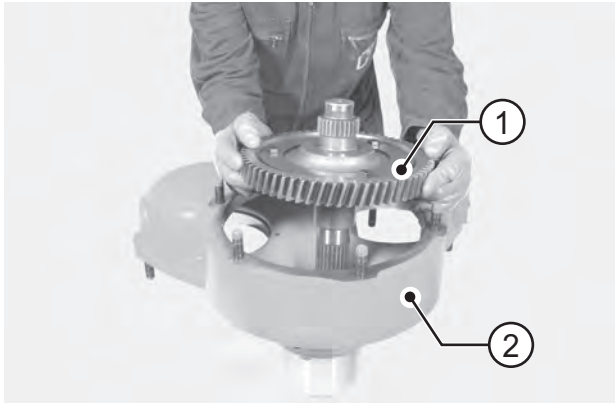

FIGURE 32: Fit the complete input shaft assembly (1) into the reduction unit (2) housing.

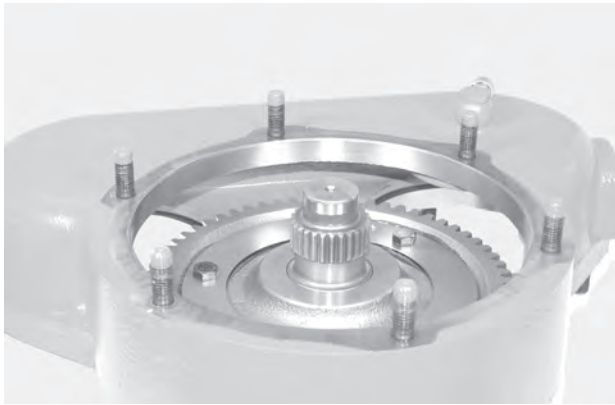

FIGURE 33: Make sure the bearing is properly engaged in its seat in the reduction unit housing.

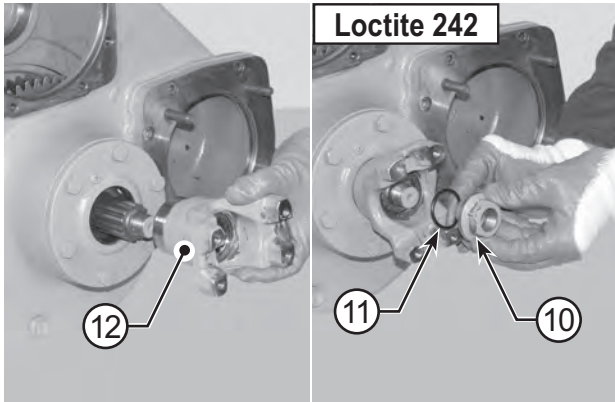

FIGURE 34: Assemble the flange (12), o-ring (11), and nut (10) using Loctite 242.

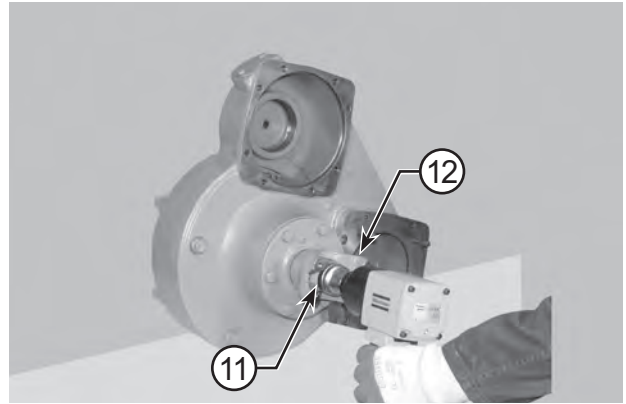

FIGURE 35: Tighten the flange (12) nut (10).

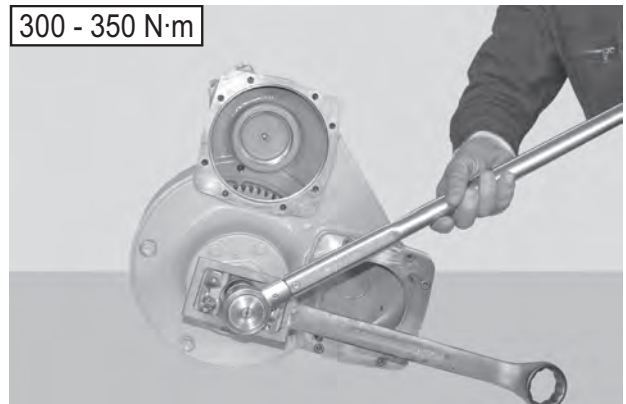

FIGURE 36: Tighten the nut (10) using a torque wrench setting of 300 - 350 N·m.

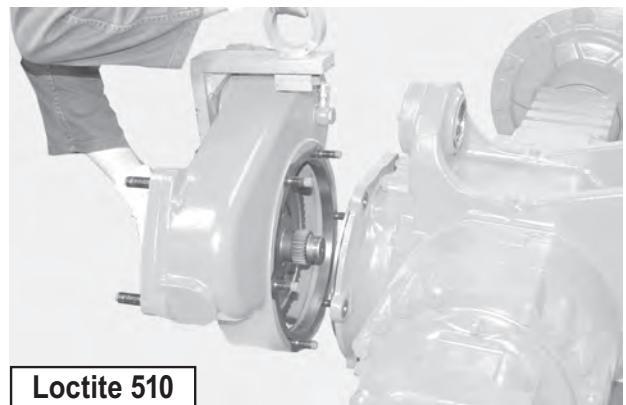

FIGURE 37: Mount the reduction unit onto the axle by spreading Loctite 510 on the surfaces.

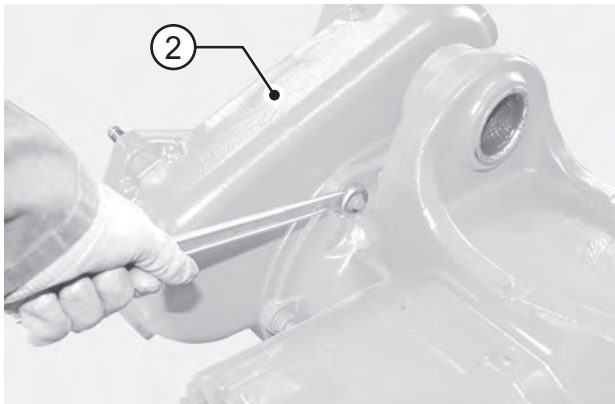

FIGURE 38: Tighten by placing the reduction unit in a vertical position in relation to the axis.

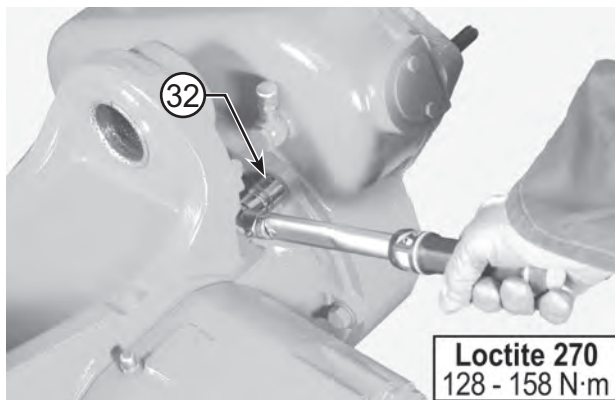

FIGURE 39: Tighten screws (32) using a torque wrench setting of 128 - 158 N·m.

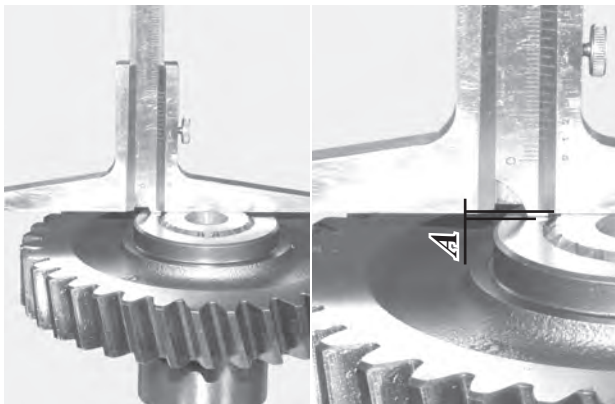

FIGURE 40: Insert gear on shaft and, determine the measure "A".

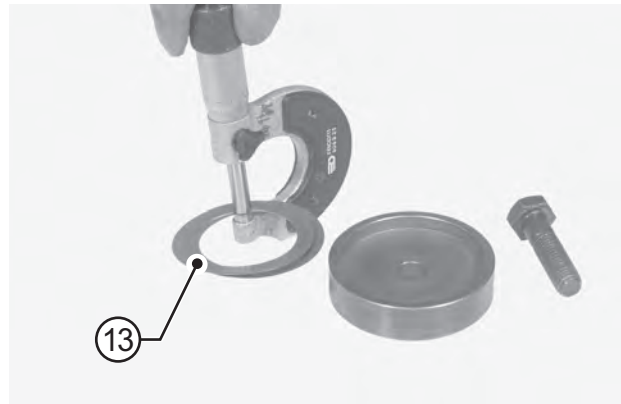

FIGURE 41: Calculation of shims S.

$$S = A - \text{Gap}$$

$$A = 1 \text{ mm}$$

$$\text{Gap} = 0,2 \text{ mm}$$

$$S = 1 \text{ mm} - 0,2 \text{ mm} = S = 0,8 \text{ mm.}$$

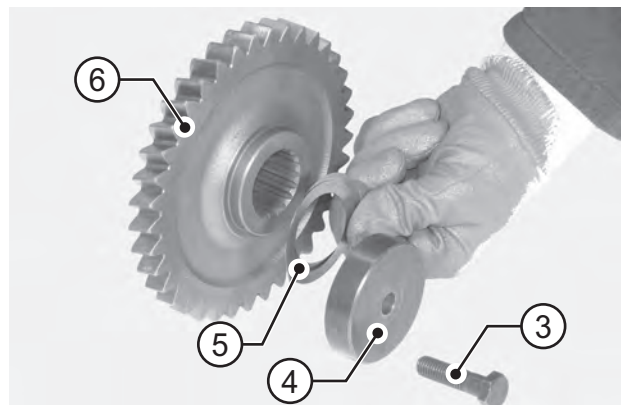

FIGURE 42: Using shims (5), reassemble the motion entrance cover components (3, 4, 5, 6).

NOTE:

Replace o-rings (8) if necessary.

INTEGRATED REDUCTION GEAR

EXPLODED VIEW

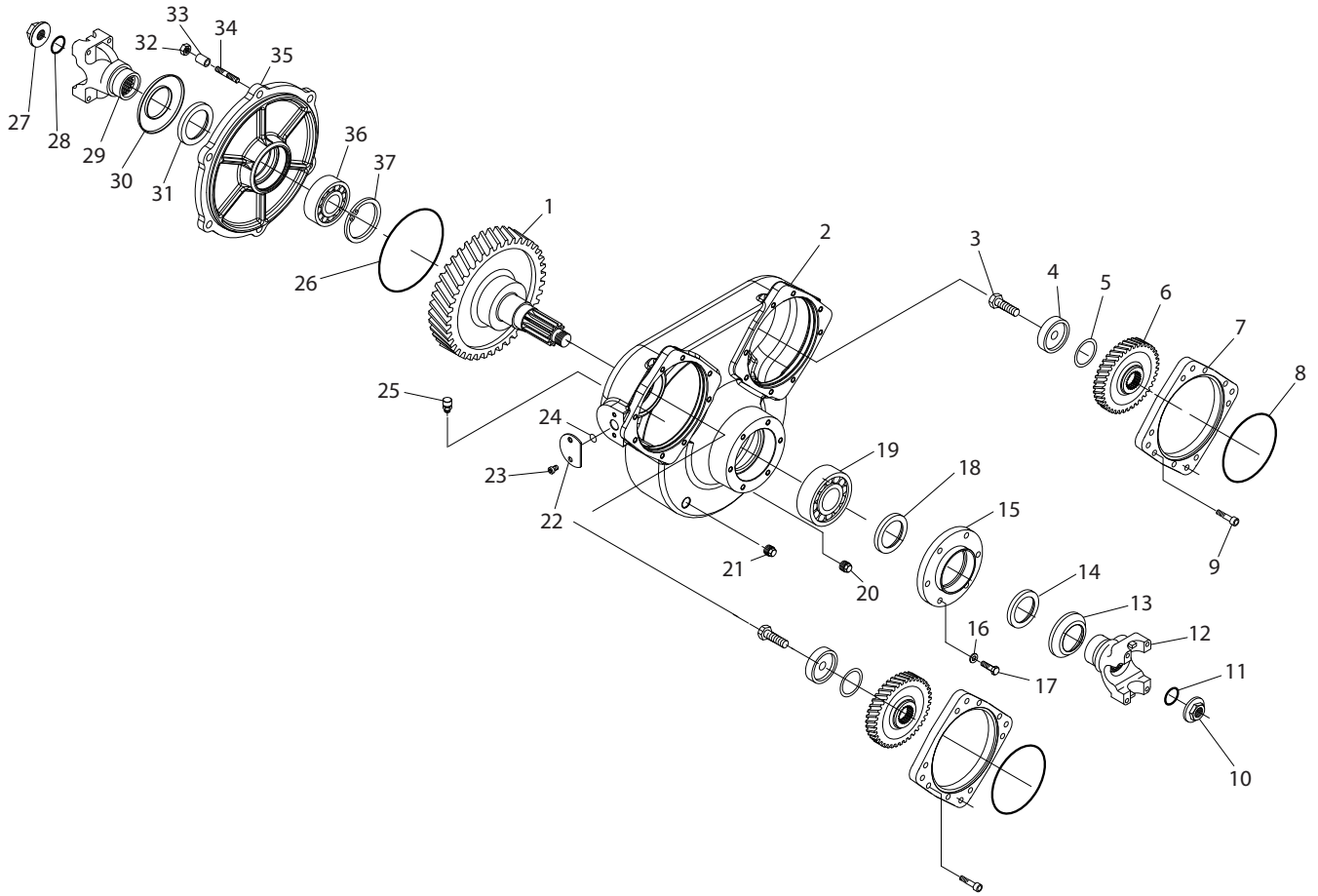

DISASSEMBLY

DISASSEMBLY

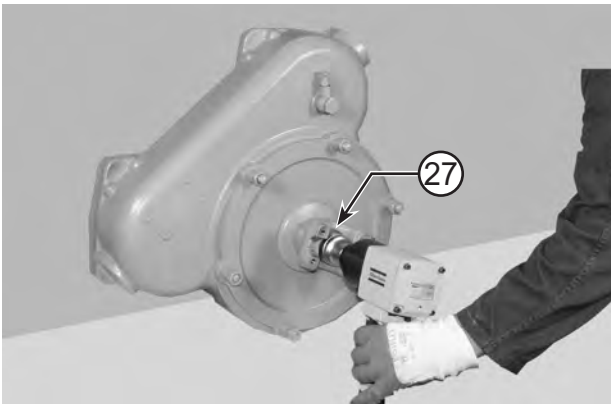
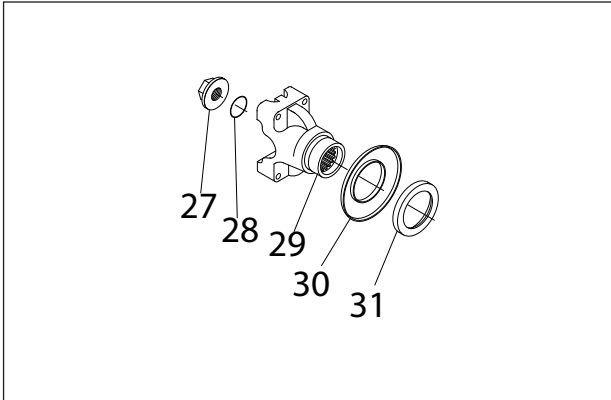

FIGURE 1: Loosen the nut from (27) the flange (29).

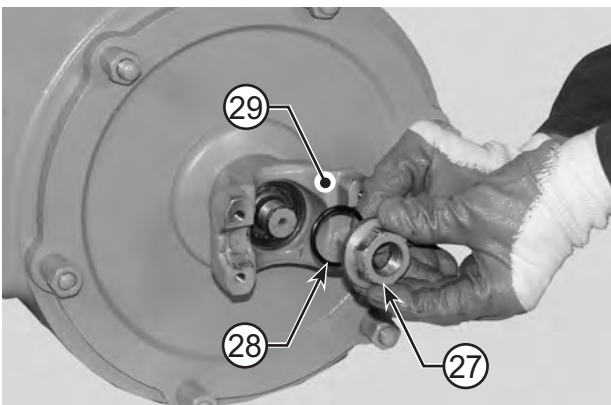

FIGURE 2: Remove the nut (27) and o-ring (28).

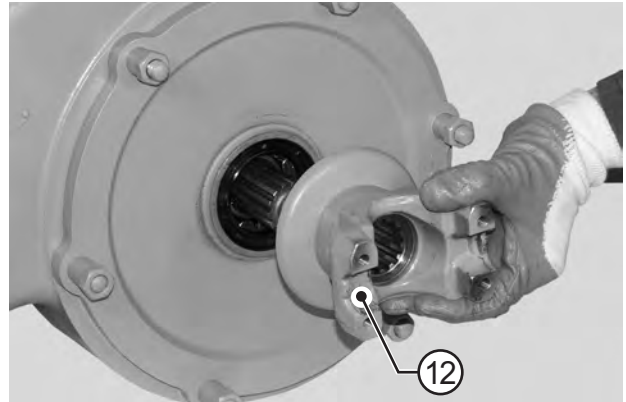

FIGURE 3: Remove the flange (29).

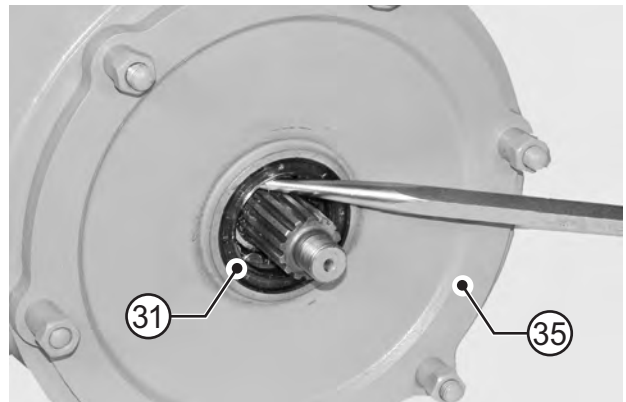

FIGURE 4: Remove the cover (35) sealing ring (31).

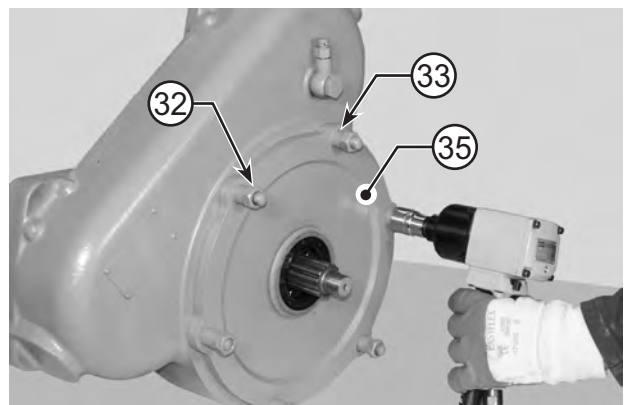

FIGURE 5: Loosen the cover (35) nuts (33).

NOTE:

Write down that washers (35) are only fitted where cover top is rough.

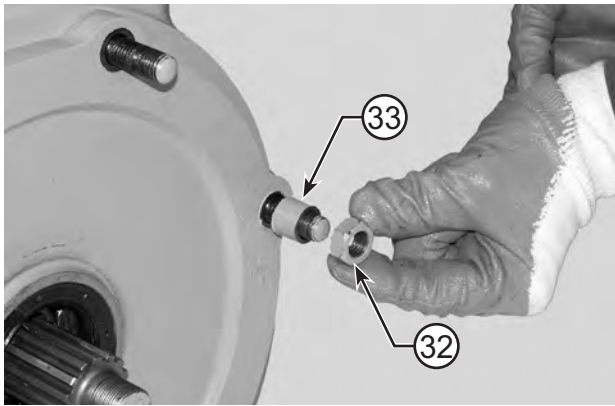

FIGURE 6: Remove the cover (33) nuts (32) and the spacers (33).

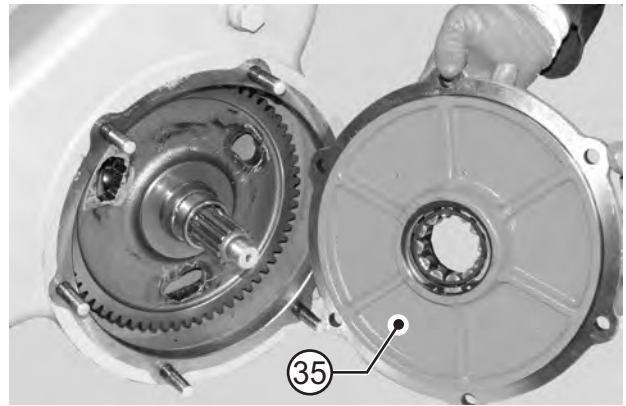

FIGURE 9: Remove the cover (35).

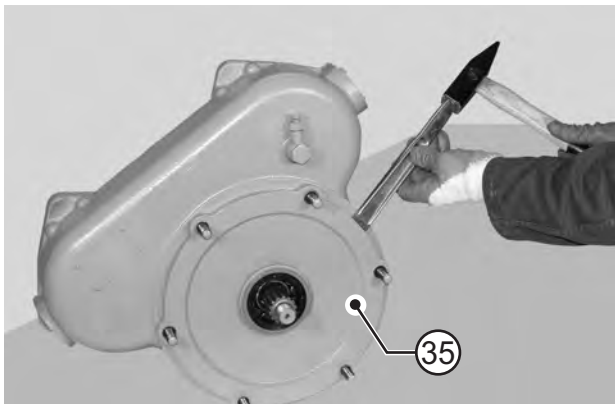

FIGURE 7: Using a driver; move and partially lift the cover (35).

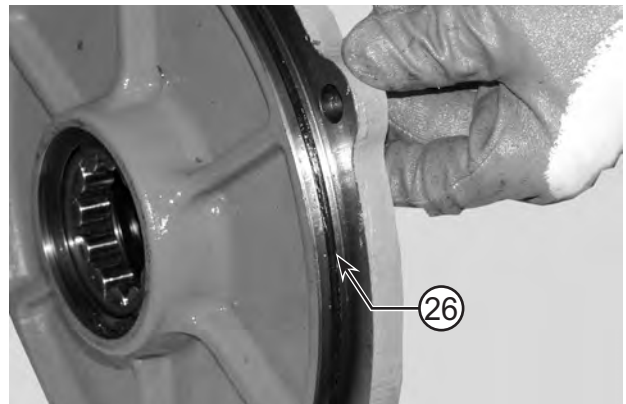

FIGURE 10: Replace the o-ring (26).



FIGURE 8: Apply adequate force, taking care not to damage surfaces.



FIGURE 11: Remove the snap rings (37).

DISASSEMBLY

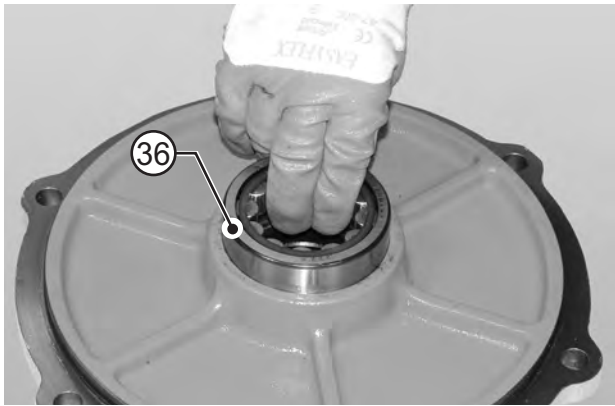

FIGURE 12: Remove the bearing (36).

ASSEMBLY

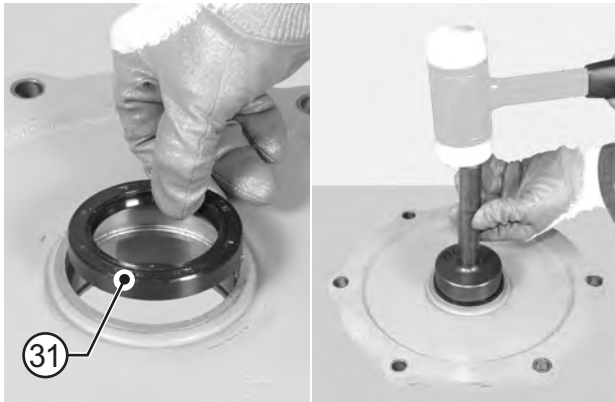

FIGURE 13: Lubricate the sealing ring (31) and install into the cover (35).

⚠ CAUTION

Pay particular attention to the direction of assembly of the ring.



FIGURE 14: Install the bearing (36).



FIGURE 15: Move the bearing to the limit stop by hammering lightly all around the edge.

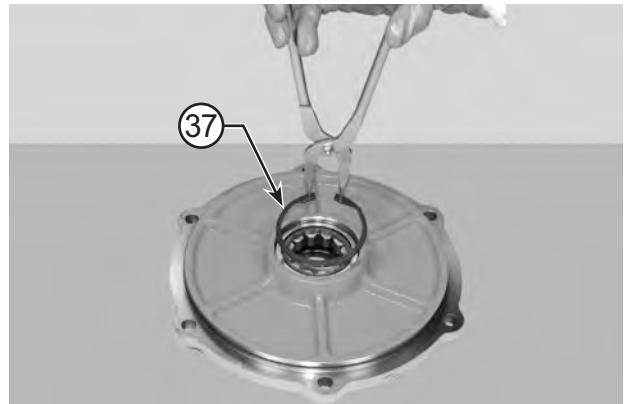

FIGURE 16: Fit the snap ring (37) on the bearing (36).

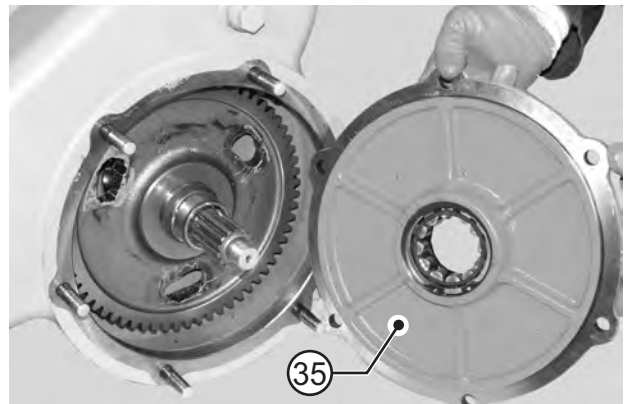

FIGURE 17: Re-assemble the cover (35) with spacers (33) and nuts (32).

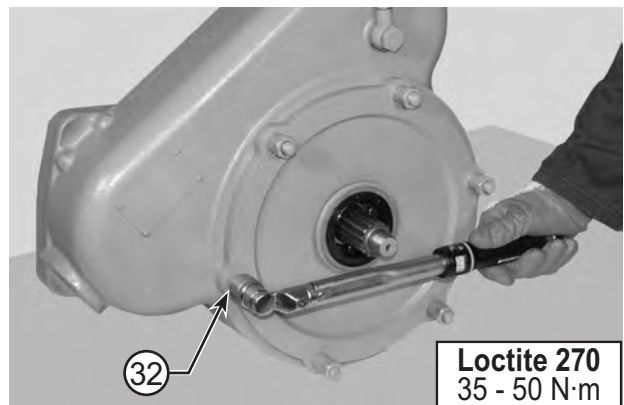

FIGURE 18: Tighten nuts (32) using a torque wrench set ting of 35 - 50 N·m.

ASSEMBLY

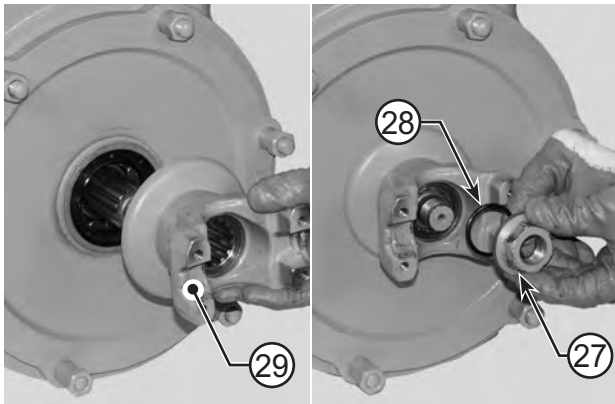

FIGURE 19: Assemble flange (29), o-ring (28) and nut (27) using Loctite 242.

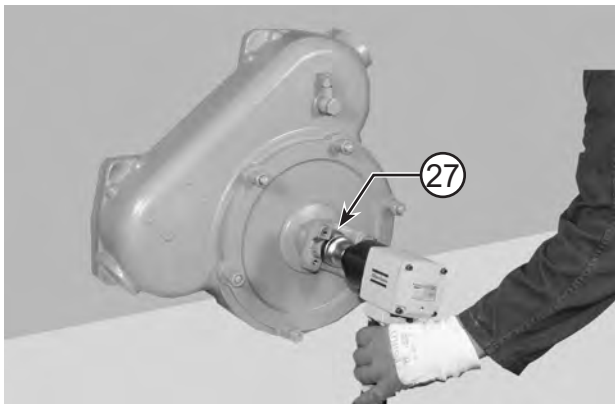

FIGURE 20: Tighten the flange (29) nut (27).

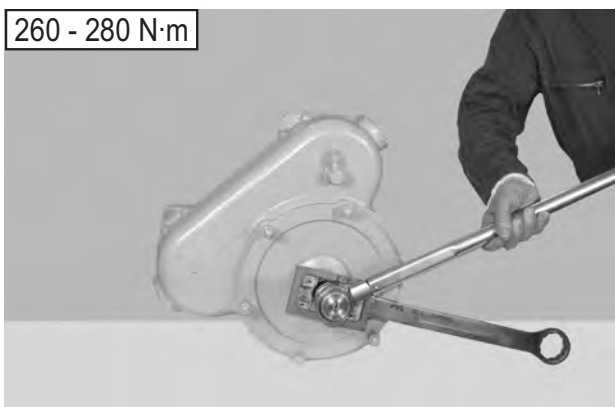

FIGURE 21: Tighten the nut using a torque wrench setting of 260 - 280 N·m.

© Copyright 2015 Dana Holding Corporation
All content is subject to copyright by Dana and may not be reproduced in whole or in part by any means, electronic or otherwise, without prior written approval.
THIS INFORMATION IS NOT INTENDED FOR SALE OR RESALE, AND THIS NOTICE MUST REMAIN ON ALL COPIES.

For product inquiries or support,
visit www.dana.com or call 419-887-6445
For other service publications,
visit www.SpicerParts.com/literature.asp
For online service parts ordering,
visit www.SpicerParts.com/order.asp



SPICER[®]
Off-Highway Products