

OPERATION AND SAFTY MANUAL

MV060-E (AMWP6-1000)

MV075-E (AMWP7.5-1000)

(AMWP7.5-2000)

(AMWP9-2000)



FOREWORD

This manual is a very important tool! Keep it with the machine at all times.

The purpose of this manual is to provide owners, users, operators, lessors, and lessees with the precautions and operating procedures essential for the safe and proper machine operation for its intended purpose.

Due to continuous product improvements, the manufacturer reserves the right to make specification changes without prior notification. Contact the manufacturer for updated information.

Other Publications Available:

Illustrated Parts Manual

SAFETY ALERT SYMBOLS AND SAFETY SIGNAL WORDS

This is the Safety Alert Symbol. It is used to alert you to the potential personal injury hazards. Obey all safety messages that follow this symbol to avoid possible injury or death.

DANGER

INDICATES AN IMMINENTLY HAZARDOUS SITUATION. IF NOT AVOIDED, WILL RESULT IN SERIOUS INJURY OR DEATH.

WARNING

INDICATES A POTENTIALITY HAZARDOUS SITUATION. IF NOT AVOIDED, COULD RESULT IN SERIOUS INJURY OR DEATH.

CAUTION

INDICATES A POTENTIALITY HAZARDOUS SITUATION. IF NOT AVOIDED, MAY RESULT IN MINOR OR MODERATE INJURY. IT MAY ALSO ALERT AGAINST UNSAFE PRACTICES.

IMPORTANT

INDICATES PROCEDURES ESSENTIAL FOR SAFE OPERATION.

WARNING

THIS PRODUCT MUST COMPLY WITH ALL SAFETY RELATED BULLETINS. CONTACT THE MANUFACTURER OR IT'S LOCAL AUTHORIZED REPRESENTATIVE FOR INFORMATION REGARDING SAFETY-RELATED BULLETINS WHICH MAY HAVE BEEN ISSUED FOR THIS PRODUCT.

IMPORTANT

THE MANUFACTURER SENDS SAFETY RELATED BULLETINS TO THE OWNER OF RECORD OF THIS MACHINE. CONTACT THE MANUFACTURER TO ENSURE THAT THE CURRENT OWNER RECORDS ARE UPDATED AND ACCURATE.

IMPORTANT

THE MANUFACTURER MUST BE NOTIFIED IMMEDIATELY IN ALL INSTANCES WHERE IT'S PRODUCTS HAVE BEEN INVOLVED IN AN ACCIDENT INVOLVING BODILY INJURY OR DEATH OF PERSONNEL OR WHEN SUBSTANTIAL DAMAGE HAS OCCURRED TO PERSONAL PROPERTY OR THE PRODUCT.

TABLE OF CONTENTS

SUBJECT-SECTION, PARAGRAPH	PAGE NO.
FOREWORD.....	1
SAFETY ALERT SYMBOLS AND SAFETY SIGNAL WORDS.....	2
 SECTION 1 - SAFETY PRECAUTIONS	
1.1 GENERAL.....	6
1.2 PRE-OPERATION.....	6
Operator Training And Knowledge.....	6
Workplace Inspection.....	6
Machine Inspection.....	7
1.3 OPERATION.....	7
General.....	7
Trip and Fall Hazard.....	7
Electrocution Hazard.....	8
Safety Rules for Electrical Control System.....	9
Tipping Hazard.....	9
Crushing And Collision Hazard.....	10
1.4 TOWING, LIFTING, AND HAULING.....	10
1.5 Plates and Warning Labels.....	10
Nameplate and CE mark.....	11
Warning labels.....	12
 SECTION 2 - PREPARATION AND INSPECTION	
2.1 PERSONNEL TRAINING.....	17
Operator Training.....	17
Training Supervision.....	17
Operator Responsibility.....	17
2.2 PREPARATION, INSPECTION, AND MAINTENANCE.....	17
2.3 PRE-START INSPECTION.....	18
2.4 DAILY WALK-AROUND INSPECTION.....	19
2.5 FUNCTION CHECK.....	20
 SECTION 3 - MACHINE CONTROLS, INDICATORS AND OPERATION	
3.1 GENERAL.....	23
3.2 MACHINE DESCRIPTION.....	23
3.3 MACHINE OPERATION.....	23
Getting Started.....	23
3.4 BATTERY CHARGING.....	23
Battery Low Voltage Warning Indicators.....	24
To Charge Batteries.....	25

Battery Charging Status Indicators.....	26
3.5 GROUND CONTROL STATION – OPERATION.....	27
Main Power Selector Switch.....	27
Emergency Stop/Shut Down Button.....	27
Brake Release Button.....	27
Platform Up.....	28
Platform Down.....	28
Manual Descent Control Valve.....	28
Machine Status LCD Display.....	30
LCD Display Fault Conditions.....	31
3.6 GROUND CONTROL STATION-PROGRAMMING.....	33
General.....	33
Programming Levels.....	33
Operator Programming Mode.....	33
Activating Programming Mode.....	34
Entering Password.....	35
Programming Mode Selection.....	36
Selecting Programmable Item to Adjust.....	36
Adjusting Programmable Setting.....	37
3.7 PLATFORM CONTROL CONSOLE OPERATION.....	38
At Ground Control Station.....	38
Emergency Stop/Shut-Down Button.....	38
Battery Charge/Fault Code LED Indicator.....	39
Driving Machine.....	39
Adjusting Maximum Drive Speed Control.....	40
Elevating/Lowering the Platform.....	41
3.8 PARKING MACHINE.....	42
3.9 PLATFORM CONFIGURATIONS.....	43
3.10 FALL PROTECTION – LANYARD ATTACHMENT.....	45
3.11 QUICK-CHANGE PLATFORM MOUNTING.....	46
Platform Removal.....	46
Platform Installation.....	46
3.12 TRANSPORTING, LIFTING PROCEDURES.....	47
General.....	47
Truck Transport.....	47
Fork Lift Truck Transport.....	48

SECTION 4 - EMERGENCY PROCEDURES

4.1 GENERAL INFORMATION.....	49
4.2 EMERGENCY OPERATION.....	49
Operator Unable to Control Machine.....	49
Platform caught Overhead.....	49
4.3 INCIDENT NOTIFICATION.....	49

SECTION 5 - GENERAL SPECIFICATIONS AND OPERATOR MAINTENANCE

5.1	INTRODUCTION.....	50
5.2	GENERAL SPECIFICATIONS.....	50
	Machine Specifications.....	50
	Machine Dimension.....	51
	Machine Operating Area.....	52
	Electrical Specifications.....	52
	Platform Data.....	53
	Machine Component Weights.....	53
	Serial Number Locations.....	53
5.3	OPERATOR MAINTENANCE.....	53
	Lubrication.....	53
	Hydraulic Diagram.....	54

SECTION 6 - INSPECTION AND REPAIR LOG**LIST OF FIGURES**

FIGURES NO.	TITLE	PAGE NO.
2-1.	Daily Walk-Around Inspection for AMWP Machines.....	20
3-1.	Battery Charger Location.....	24
3-2.	Ground Control Station. (Machine Rear View)	29
3-3.	Platform Control Console.	38
3-4.	Forklift Truck Lifting Pockets and Machine Tie Down Bar Locations.....	48

LIST OF TABLES

TABLE NO.	TITLE	PAGE NO.
1-1	Minimum Safe Approach Distance (M.S.A.D.).	8
2-1	Inspection and Maintenance Table.....	18
3-1	Machine Operating Specifications.....	22
3-2	Battery Low Voltage Warning Indicators.....	25
3-3	LCD Display – Operating Fault Conditions.....	32
3-4	Ground Control Station – Level 3 – Programmable Settings and Factory Presets.....	34
5-1	Lubrication Specifications.....	55
5-2	Lubrication Intervals for Various Components.....	56
6-1	Inspection and Repair Log.....	57

SECTION 1. SAFETY PRECAUTIONS

1.1 GENERAL

This section outlines the necessary precautions for proper and safe machine usage and maintenance. For proper machine use, it is mandatory that a daily routine be established based on the content of this manual. A maintenance program, using the information provided in this manual and the Service and Maintenance Manual, must also be established by a qualified person and must be followed to ensure that the machine is safe to operate.

The owner/user/operator/lessor/lessee of the machine should not accept operating responsibility until this manual has been read, training is accomplished, and operation of the machine has been completed under the supervision of an experienced and qualified operator.

If there are any questions with regard to safety, training, inspection, maintenance, application, and operation, please contact the manufacturer.

WARNING

FAILURE TO COMPLY WITH THE SAFETY PRECAUTIONS LISTED IN THIS MANUAL COULD RESULT IN MACHINE DAMAGE, PROPERTY DAMAGE, PERSONAL INJURY OR DEATH.

1.2 PRE-OPERATION

Operator Training And Knowledge

- Read and understand this manual before operating the machine.
- Do not operate this machine until complete training is performed by authorized persons.
- Only authorized and qualified personnel can operate the machine.
- Read, understand, and obey all DANGERS, WARNINGS, CAUTIONS, and operating instructions on the machine and in this manual.
- Use the machine in a manner, which is within the scope of its intended application set by the manufacturer.
- All operating personnel must be familiar with the emergency controls and emergency operation of the machine as specified in this manual.
- Read, understand, and obey all applicable employers, local, and governmental regulations as they pertain to operation of the machine.

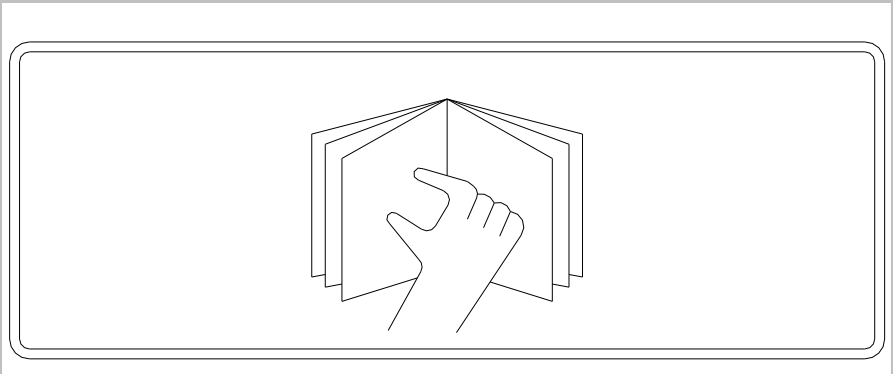

Workplace Inspection

- The operator is to take safety measures to avoid all hazards in the work area prior to machine operation.
- Do not operate or raise the platform while on trucks, trailers, railway cars, floating vessels, scaffolds or other equipment unless approved in writing by the manufacturer.
- This machine can be operated in temperatures of -20°C to 40°C . Consult the manufacturer for operation outside this range.

Machine Inspection

- Before machine operation, perform inspections and functional checks. Refer to Section 2 of this manual for detailed instructions.
- Do not operate this machine until it has been serviced and maintained according to requirements specified in the Service and Maintenance Manual.
- Ensure all safety devices are operating properly. Modification of these devices is a safety violation.

WARNING

MODIFICATION OR ALTERATION OF AN AERIAL WORK PLATFORM SHALL BE MADE ONLY WITH PRIOR WRITTEN PERMISSION FROM THE MANUFACTURER

- Do not operate any machine on which the safety or instruction placards or decals are missing or illegible.
- Avoid any build up of debris on platform floor. Keep mud, oil, grease, and other slippery substances from footwear and platform floor.

1.3 OPERATION

General

- Do not use the machine for any purpose other than positioning personnel, their tools and equipment, or for hand stock picking.
- Never operate a machine that is not working properly. If a malfunction occurs, shut down the machine.
- Never slam a control switch or lever through neutral to an opposite direction. Always return switch to neutral and stop before moving the switch to the next function. Operate controls with slow and even pressure.
- Do not allow personnel to tamper with or operate the machine from the ground with personnel in the platform, except in an emergency.
- Do not carry materials directly on platform railing unless approved by the manufacturer.
- Always ensure that power tools are properly stowed and never left hanging by their cord from the platform work area.
- Fully lower mast assembly and shut off all power before leaving machine.
- When performing welding operations at elevation, precautions must be taken to protect all machine components from contact with weld splatter or molten metal.
- Battery fluid is highly corrosive. Avoid contact with skin and clothing at all times.
- Charge batteries on in a well ventilated area.

Trip and Fall Hazard

- The manufacturer recommends that the operator in the platform wear a full body harness with a lanyard attached to an authorized lanyard anchorage point. For further information regarding fall protection requirements on the products, contact the manufacturer.



- Before operating the machine, make sure all railing and gates are fastened in their proper position.



- Keep both feet firmly positioned on the platform floor at all times. Never use ladders, boxes, steps, planks, or similar items on platform to provide additional reach.
- Never use the mast assembly to enter or leave the platform.
- Use extreme caution when entering or leaving platform. Ensure that the mast assembly is fully lowered. Face the machine when entering or leaving the platform. Always maintain “three point contact” with the machine, using two hands and one foot or two feet and one hand at all times during entry and exit.
- Platform-to-structure transfers at elevated positions are discouraged. Where transfer is necessary, enter/exit through the gate only with the platform within 1 foot (0.3m) of a safe and secure structure. 100% tie-off is also required in this situation utilizing two lanyards. One lanyard must be attached to the platform with the second lanyard attached to the structure. The lanyard connected to the platform must not be disconnected until such time the transfer to the structure is safe and complete.

Electrocution Hazard

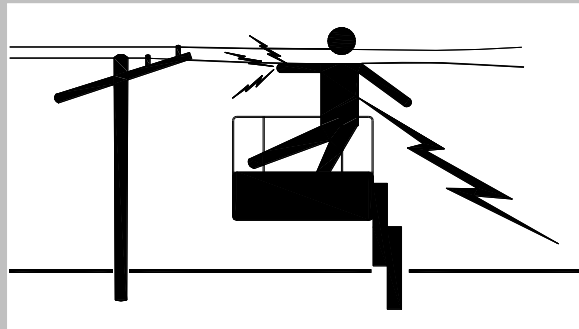

Table 1-1. Minimum Safe Approach Distance (M.S.A.D.)

VOLTAGE RANGE (PHASE TO PHASE)	MINIMUM SAFE APPROACH DISTANCE-Feet (m)
0-50KV	10(3)
Over 50KV to 200KV	15(5)
Over 200KV to 350KV	20(6)
Over 350KV to 350KV	25(8)
Over 500KV to 750KV	35(11)
Over 750KV to 1000KV	45(14)
NOTE: This Minimum Safe Approach Distance shall apply except where employer, local, or governmental regulations are more stringent.	

Maintain a clearance of at least 10 ft (3m) between any part of the machine and its occupants, their tools, and their equipment from any electrical line or apparatus carrying up to 50,000 volts. One foot (0.3m) additional clearance is required for every additional 30,000 volts or less.

The minimum safe approach distance may be reduced if insulating barriers are installed to prevent contact, and if the barriers are rated for the voltage of the line being guarded. These barriers shall not be part of (or attached to) the machine. The minimum safe approach distance shall be reduced to a distance within the designed working dimensions of the insulating barrier. This determination shall be made by a qualified person in accordance with employer, local, or governmental requirements for work practices near energized equipment.

Safety Rules for Electrical Control System

- Only personnel who are properly trained and have adequate knowledge and skill should undertake all electrical/electronic troubleshooting and repair.
- Do not alter or bypass protective interlocks.
- Before starting, read and observe all warning labels.
- When trouble shooting make sure the power source has been disconnected and main switch has been locked.
- Take extra precautions in damp areas to protect you from accidental grounding.
- Before applying power to any equipment it must be established, without a doubt, that all persons are clear.
- Do not open the electrical control panel unless it is necessary to check the electrical equipment.
- Do not alter the electrical circuits unless authorized to do so by the manufacturer.
- When replacing electrical components, make sure they conform to the manufacturer's specifications, including proper color coding.
- Do not wear metal frame glasses, metallic necklaces or chains while working on any electrical equipment. Also do not wear any ring, watch or bracelet while operating electrical equipment.

Tipping Hazard

- The user should be familiar with the surface before driving. Do not exceed the allowable side slope and grade while driving.

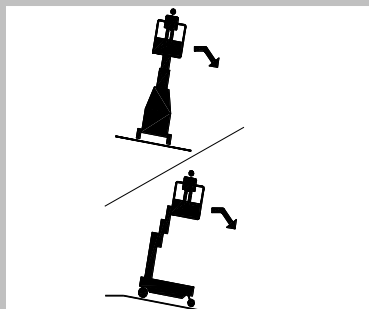

- Do not elevate platform or drive with platform elevated while on a slope, or on an uneven or soft surface.
- Before driving on floors, bridges, trucks, and other surfaces, check allowable capacity of the surfaces.
- Never exceed the maximum platform capacity. Distribute loads evenly on platform floor.
- Keep the chassis of the machine a minimum of 2 ft. (0.6m) from holes, bumps, drop-offs, obstructions, debris, concealed holes, and other potential hazards at the ground level.
- Never attempt to use the machine as a crane. Do not tie-off machine to any adjacent structure.
- Do not increase the platform size with unauthorized deck extensions or attachments, increasing the area exposed to wind will decrease stability.
- If mast assembly or platform is caught so that one or more wheels are off the ground, the operator must be removed before attempting to free the machine. Use cranes, forklift trucks, or other appropriate equipment to stabilize machine and remove personnel.

Crushing And Collision Hazard

- Personal protection equipment must be worn by all operating and ground personnel.
- Check work area clearances above, on sides, and bottom of platform while driving and lifting or lowering platform



- During operation, keep all body parts inside platform railing.
- Always post a lookout when driving in areas where vision is obstructed.
- Keep non-operating personnel at least 6 ft. (1.8m) away from machine during all driving operations.
- Limit travel speed according to conditions of ground surface, congestion, visibility, slope, location of personnel, and other factors causing hazards of collision or injury to personnel.
- Be aware of stopping distances in restricted or close quarters or when driving in reverse.
- Do not drive at high speeds in restricted or close quarters or when driving in reverse.
- Exercise extreme caution at all times to prevent obstacles from striking or interfering with operating controls and persons in the platform.
- Ensure that operators of other overhead and floor level machines are aware of the aerial work platform's presence. Disconnect power to overhead cranes.
- Warn personnel not to work, stand, or walk under a raised platform. Position barricades on floor as necessary.

1.4 TOWING, LIFTING, AND HAULING

- Never allow personnel in platform while towing, lifting, or hauling.
- This machine should not be towed, except in the event of emergency, malfunction, power failure, or loading/unloading. Refer to the Emergency Procedures Section of this manual for emergency towing procedures.
- Ensure platform is fully retracted and completely empty of tools prior to towing, lifting or hauling.
- Do not assist a stuck or disabled machine by pushing or pulling except by pulling at the chassis tie-down bars.
- When lifting machine with a forklift, position forks only at designated areas of the machine. Lift with a forklift of adequate capacity.
- Refer to the Machine Operation section of this manual for lifting information.

1.5 Plates and Warning Labels

Upon unpacking, check the plates and warning labels. Do not operate the machine on which the plates or labels are missing or illegible. Contact the dealer immediately.

The following plates are visible on the machine.

• Nameplate and CE mark

	
AERIAL WORK PLATFORM	
	No. <input type="text"/>
ITEM SPECS	<input type="text"/>
VOLTAGE	<input type="text"/> V
CAPACITY	<input type="text"/> kg
POWER	<input type="text"/> kW
PLATFORM HEIGHT	<input type="text"/> m
RATED PRESSURE	<input type="text"/> Mpa
DELIVERY DATE	<input type="text"/>
DIMENSION	<input type="text"/> × <input type="text"/> × <input type="text"/> m
9221015	



• Warning labels

AMWP SERIES DECAL INSPECTION

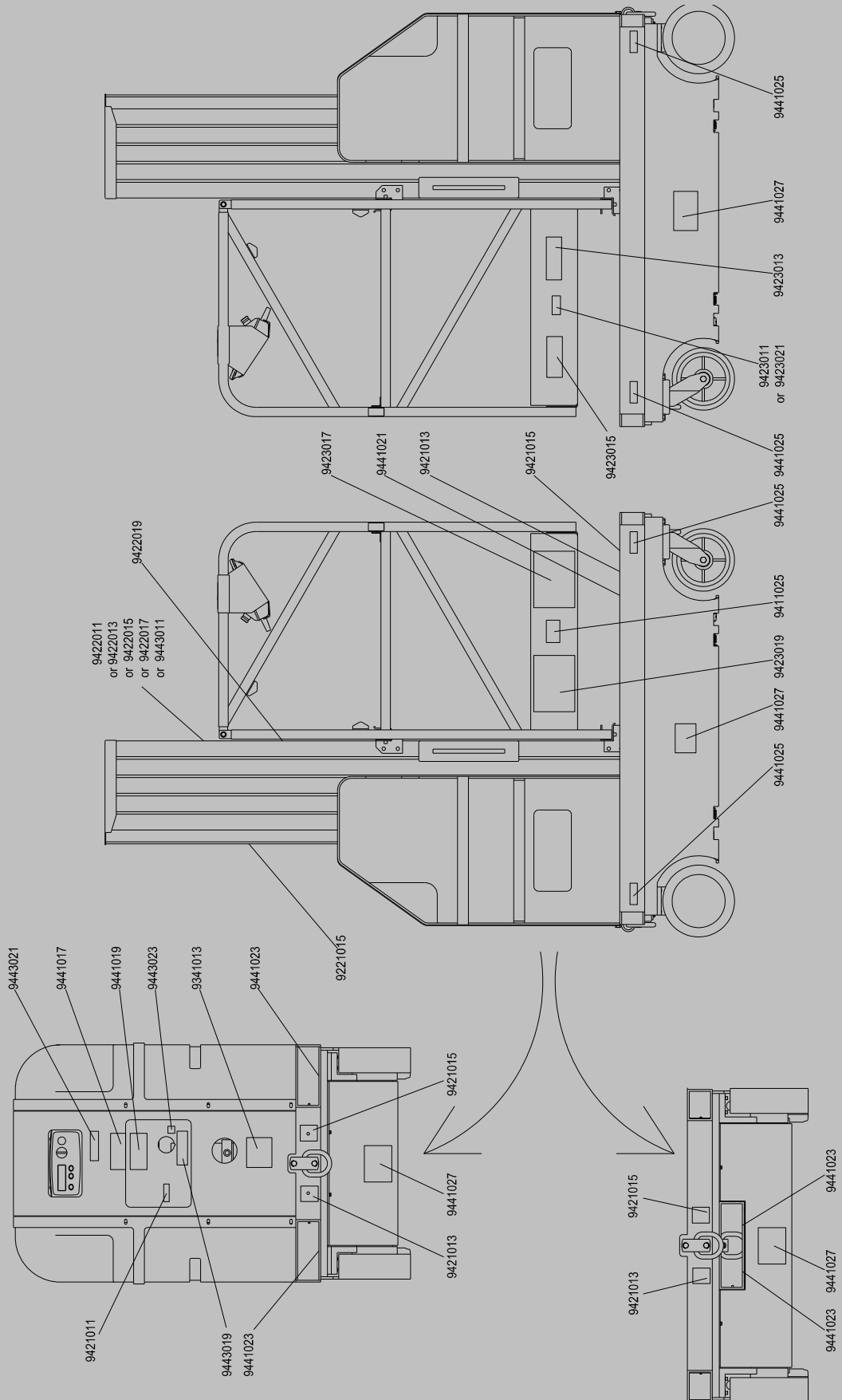

AWMP SERIES DECAL INSPECTION

Part No.	Description	QTY.
9221015	Machinery label	1
9341013	Notice—Draw out to manual lower platform	1
9421011	Notice—Power	1
9421013	Notice—Tie down	2
9421015	Notice—Hook	2
9422011	Notice—Rated capacity of standard platform AMWP7.5:125kgs(single) Or Rated capacity of extension platform AMWP6:125kgs(single) Or Rated capacity of extension platform AMWP9:125kgs(twin)	1
9422013	Notice—Rated capacity of extension platform 7.5m:100kgs(single)	1
9422015	Notice—Rated capacity of standard platform AMWP6:150kgs(single) Or Rated capacity of standard platform AMWP9:150kgs(twin)	1
9422017	Notice—Rated capacity of extension platform AMWP7.5:175kgs(twin)	1
9422019	Warning—This machine must not be used until it is inspected and operating properly	1
9423011	Notice—Allowed number of persons: ONE	1
9423013	Important—Move with brake released	1
9423015	Danger—Electrocution hazard	1
9423017	Warning—Tip-over hazard	1
9423019	Warning—Crushing hazard Or Falling hazard	1
9423021	Notice—Allowed number of persons: TWO	1
9411025	CE label	1
9441017	Notice—Charging usage	1
9441019	Warning—Timely charging	1
9441021	Danger—Please don't stand	1
9441023	Warning—Here with fork	2
9441025	Notice—Tyre Max. capacity 350 kg	4
9441027	Warning—Here without fork	3
9443011	Notice—Rated capacity of standard platform AMWP7.5:200kgs(twin)	1
9443019	Notice—Recharging lasts at least 12 hours.	1
9443021	Notice—Please cut off the power after operating.	1
9443023	Label—Directional arrows	1
<p>Decal Inspection:</p> <p>Use the pictures on the next page to verify that all decals are legible and in place.</p> <p>Below is a numerical list with quantities and descriptions.</p>		

NOTICE

CHARGING USAGE
 This is only one position to charge. If you charge at any other error situation, this will be result in dangerous and hazardous aftermath.

9441017

WARNING

TIMELY CHARGING
 When operating the machine , if you find it can not be travelling, lifting or steering etc.,please charge in time.

9441019

IMPORTANT

MOVE WITH BRAKE RELEASED
 1. The brake release button is on the ground control station.
 2. When move the machine manually or by a tractor, you must release the brake first.

9423013

DANGER

ELECTROCUTION HAZARD
 1. This machine is not insulated.
 2. Maintain a clearance of at least 10ft. between any part of machine or load and any electrical line or apparatus charged up to 50,000 volts.
 3. One foot additional clearance is required for each additional 30,000 volts or less.
 4. Allowances must be made for operator error, machine deflection and electrical line swaying.
 Death or serious injury will occur from contact or being too close to electrical lines.

9423015

NOTICE:
 For the initial use or use after long periods of storage. Please charge the battery before use. Recharging lasts at least 12 hours.

9443019

NOTICE:
 FOR SAVING THE ELECTRICITY, PLEASE CUT OFF THE POWER AFTER OPERATING.

9443021

power 100% 85% 70% 50% ≤30%

9421011

CAPACITY:100kg

9422013

CAPACITY:125kg

942011

CAPACITY:150kg

9422015

CAPACITY:175kg

942017

CAPACITY:200kg

9443011

ALLOWED NUMBER OF PERSONS

ONE



9423011

ALLOWED NUMBER OF PERSONS

TWO

9423021

 	<h2 style="text-align: center;">WARNING</h2> <h3 style="text-align: center;">TIP-OVER HAZARD</h3> <ol style="list-style-type: none"> 1. Do not exceed platform rated capacity or rated number of people. Evenly distribute load. 2. Do not expose platform to high winds or horizontal forces. 3. Machine must be on smooth, firm and level surface before elevating platform. 4. Do not drive with platform raised, or raise platform when on uneven, sloping or soft surfaces including trucks, trailers, railway cars, floating vessels, scaffolds or similar areas. 5. Do not drive near drop offs, holes or other hazards. 6. Make sure operating surface will support the machine. 7. Make sure all tires are in good condition. 8. If required, outriggers or stabilizer shall be extended and properly set. 9. Do not carry sheet type materials (i.e. drywall, plywood, roof panels) outdoors or in any windy conditions as they may act as a wind sail. <p style="text-align: center;">Death or serious injury could occur from a tip-over.</p> <p style="text-align: right;">9423017</p>
---------------------------------------------------------------------------------------------------------------------------------------------------------------------	---------------------------------------------------------------------------------------------------------------------------------------------------------------------------------------------------------------------------------------------------------------------------------------------------------------------------------------------------------------------------------------------------------------------------------------------------------------------------------------------------------------------------------------------------------------------------------------------------------------------------------------------------------------------------------------------------------------------------------------------------------------------------------------------------------------------------------------------------------------------------------------------------------------------------------------------------------------------------------------------------------------------------------------------------------------------------------------------------------------------------------------------------------------------------------------------------

 	<h2 style="text-align: center;">WARNING</h2> <h3 style="text-align: center;">CRUSHING HAZARD</h3> <ol style="list-style-type: none"> 1. Always look in the direction of movement. 2. Keep clear of obstructions. 3. Keep all body parts inside platform during operation. <p style="text-align: center;">Failure to follow instructions could result in death or serious injury.</p>
	<h3 style="text-align: center;">FALLING HAZARD</h3> <ol style="list-style-type: none"> 1. Keep both feet on platform floor. 2. Do not climb, sit or stand on platform guard rails. 3. Ensure entrance area is properly closed. 4. Do not use planks, ladders or similar items in platform to get added reach. 5. All guard rails must be properly installed during operation. <p style="text-align: center;">Falling from platform could cause death or serious injury.</p> <p style="text-align: right;">9423019</p>

 <h2 style="text-align: center;">WARNING</h2> <p>THIS MACHINE MUST NOT BE USED UNTIL IT IS INSPECTED AND OPERATING PROPERLY:</p> <ol style="list-style-type: none"> 1. Do not operate this machine unless you have been properly trained as described in the OPERATION AND SAFETY MANUAL by a qualified person and authorized to operate this machine. Your training includes reading and understanding the safety, operating and maintenance instructions in manufacturer's manuals, knowing your employers work rules and applicable governmental regulations. 2. Follow the instructions in the Operating Manual and applicable standards for daily, frequent, and annual inspections. 3. Do not replace items (i.e. batteries, wheels, counterweight, etc.) with items of different weight or specification because this will affect stability of machine. 4. Do not modify or change machine without written approval from manufacturer. 5. Operate this machine with extreme caution. STOP all operation if malfunction occurs. 6. Improper use of this machine could cause death or serious injury. <p style="text-align: right;">9422019</p>

 <h2 style="text-align: center;">DANGER</h2>  <p style="text-align: center;">Please don't stand</p> <p style="text-align: right;">9441021</p>

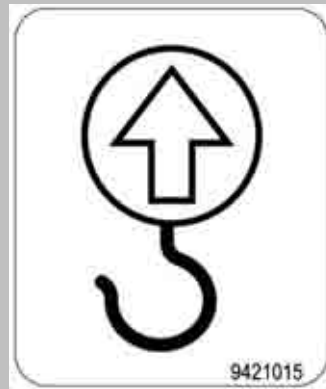
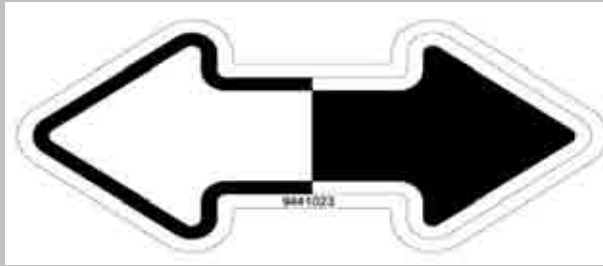

SECTION 2. PREPARATION AND INSPECTION

2.1 PERSONNEL TRAINING

The aerial platform is a personnel-handling device; so it is necessary that it be operated and maintained only by trained personnel.

Persons under the influence of drugs or alcohol or who are subject to seizures, dizziness or loss of physical control must not operate this machine.

Operator Training

Operator training must cover:

1. Use and limitations of the controls in the platform and at the ground, emergency controls and safety systems.
2. Control labels, instructions, and warnings on the machine.
3. Rules of the employer and government regulations.
4. Use of approved fall protection device.
5. Enough knowledge of the mechanical operation of the machine to recognize a malfunction/
6. The safest means to operate the machine where overhead obstructions, other moving equipment, and obstacles, depressions, holes, drop-offs are present.
7. Means to avoid the hazards of unprotected electrical conductors.
8. Specific job requirements or machine application.

Training Supervision

Training must be done under the supervision of a qualified person in an open area free of obstructions until the trainee has developed the ability to safely control and operate the machine.

Operator Responsibility

The operator must be instructed that he/she has the responsibility and authority to shut down the machine in case of a malfunction or other unsafe condition of either the machine or the job site.

NOTE: The Manufacturer or Distributor will provide qualified people for training assistance with the first unit(s) delivered and from that time forward as requested by the user or his/her personnel.

2.2 PREPARATION, INSPECTION, AND MAINTENANCE

The following table covers the periodic machine inspections and maintenance recommended by the manufacturer. consult local regulations for further requirements for aerial work platforms. The frequency of inspections and maintenance must be increased as necessary when the machine is used in a harsh or hostile environment, if the machine is used with increased frequency, or if the machine is used in a severe manner.

IMPORTANT

THE MANUFACTURER RECOGNIZES A QUALIFIED MECHANIC AS A PERSON WHO HAS SUCCESSFULLY COMPLETED THE SERVICE TRAINING FOR THE SPECIFIC PRODUCT MODEL.

Table 2-1. Inspection and Maintenance Table

TYPE	FREQUENCY	PRIMARY RESPONSIBILITY	SERVICE QUALIFICATION	REFERENCE
Pre-Start Inspection	Before using each day, or whenever there's an Operator change.	User or Operator	User or Operator	Operator and Safety Manual
Pre-Delivery Inspection (See Note)	Before each sale, lease, or rental delivery.	Owner, Dealer, or User	Qualified Mechanic	Service and Maintenance Manual and applicable Inspection form
Frequent Inspection	In service for 3 months or 150 hours, whichever comes first; or; Out of service for a period of more than 3 months; or Purchased used.	Owner, Dealer, or User	Qualified Mechanic	Service and Maintenance Manual and applicable Inspection form
Annual Machine Inspection	Annually, no later than 13 months from the date of prior inspection.	Owner, Dealer, or User	Qualified Mechanic	Service and Maintenance Manual and applicable Inspection form
Preventative Maintenance	At intervals as specified in the Service and Maintenance Manual.	Owner, Dealer, or User	Qualified Mechanic	Service and Maintenance Manual

NOTE: Inspection forms are available from the manufacture. Use the Service and Maintenance Manual to perform inspections.

2.3 PRE-START INSPECTION

The Pre-Start Inspection should include each of the following:

1. **Cleanliness** – Check all surfaces for leakage (oil, fuel, or battery fluid) or foreign objects. Report any leakage to the proper maintenance personnel.
2. **Decals and Placards** – Check all for cleanliness and legibility. Make sure no decals or placards are missing. Make sure all illegible decals and placards are cleaned or replaced. .
3. **Operators and Safety Manuals** – Make sure a copy of the Operation and Safety Manual, Safety Manual, and Manual of Responsibilities is enclosed.
4. **Daily Walk - Around Inspection** – (See Section 2.4)
5. **Battery** – Charge as required.
6. **Hydraulic Oil** – Check the hydraulic oil level.

NOTE: Check Service Manual for instructions and hydraulic oil specification before adding. DO NOT OVERFILL.

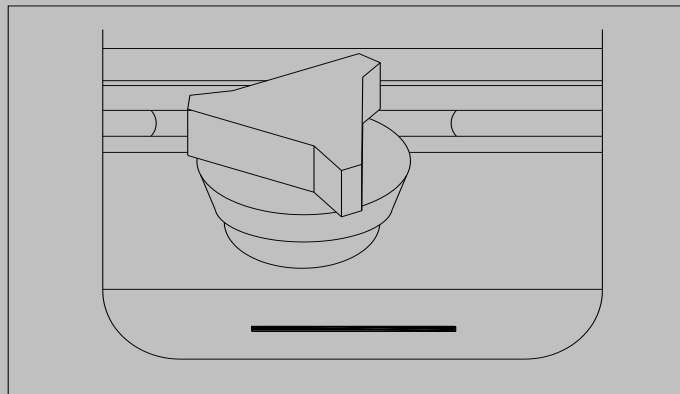

7. **Function Check** – Check all machine controls for operation. (See Section 2.5)

If optional equipment is installed on this machine refer to Section 3 for specific Pre-Start Inspection and Operation instructions.

2.4 DAILY WALK-AROUND INSPECTION

Begin the “Walk – Around Inspection” at item one (1) as noted on the diagram. Continue around machine check each item in sequence for the conditions listed in the following checklist.

WARNING

TO AVOID POSSIBLE INJURY, BE SURE MACHINE POWER IS “OFF” DURING “WALK-AROUND INSPECTION”.

DO NOT OPERATE MACHINE UNTIL ALL MALFUNCTIONS HAVE BEEN CORRECTED.

IMPORTANT

DO NOT OVERLOOK VISUAL INSPECTION OF THE BASE FRAME UNDERSIDE. CHECK THIS AREA FOR OBJECTS OR DEBRIS, WHICH COULD CAUSE EXTENSIVE MACHINE DAMAGE.

NOTE: On all components, make sure there are no loose or missing parts, that they are securely fastened, and that no visible damage, leaks or excessive wear exists in addition to any other criteria mentioned.

1. **Drive and Caster Wheels** – Check for any debris stuck to or around wheels.
2. **Base Frame** – Check pot-hole-protection system components; check for loose wires or cables dangling below the base.
3. **Manual Descent Control Valve** – See note above.
4. **Motor/Pump/Reservoir Unit** – No evidence of hydraulic leaks.
5. **Batteries** – Battery cables; no corrosion.
6. **Platform Assembly and Gate** – Quick-Change platform mounting and mounting screws; platform fasteners; platform railings; entry bar or gate in proper working order.
7. **Platform Control console** – Platform control; placards secure and legible; emergency stop switch reset for operation; Control markings legible.
8. **Ground Control Station** – Main Power Selector Switch operable; placards secure and legible; emergency stop switch operates properly.
9. **Mast Assembly** – Mast sections; slide pads; mast chains; sequencing cables; platform control and power cables (on side of mast); power cables properly tensioned and seated in sheaves; cable sheaves rotating freely.

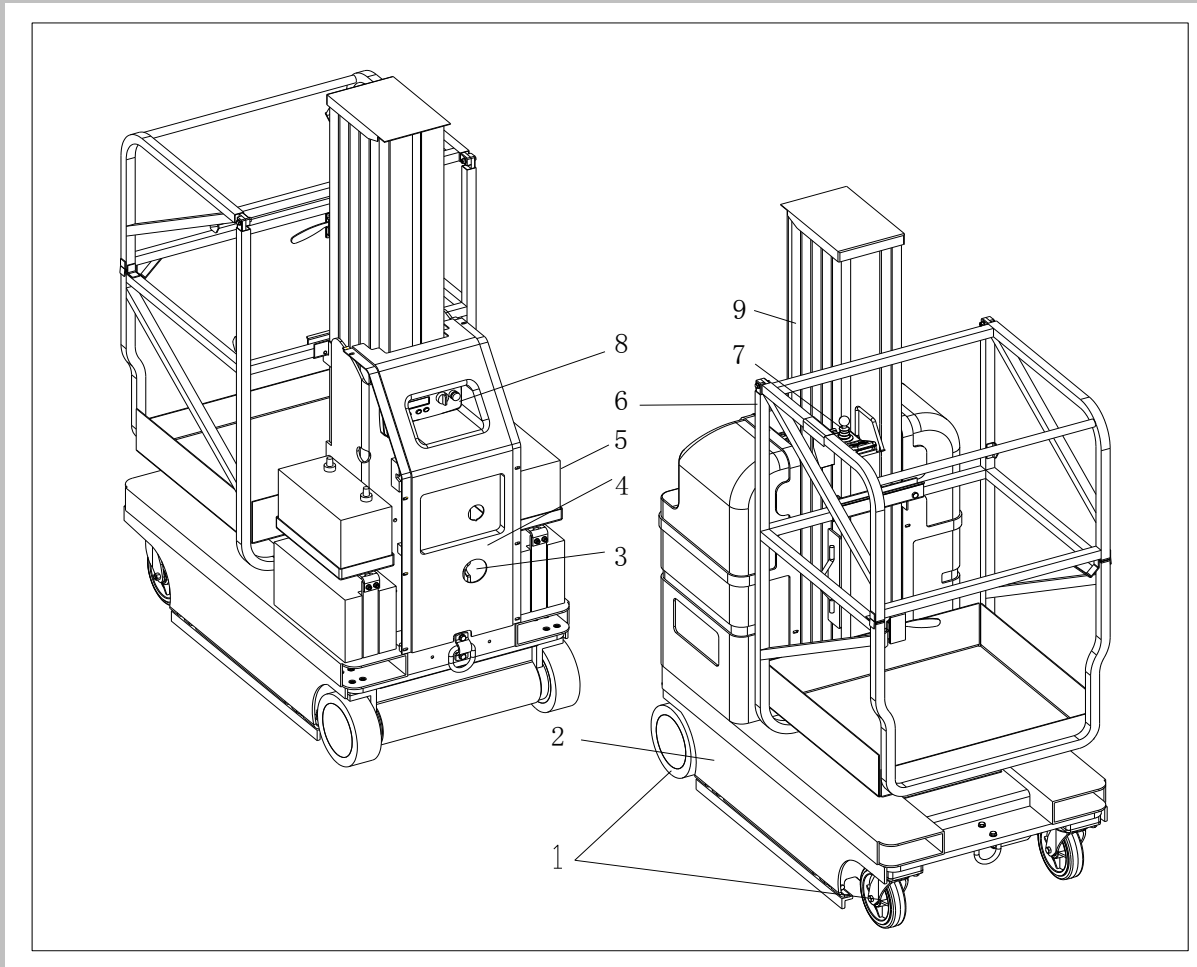

Figure 2-1. Daily Walk-Around Inspection for AMWP Machines.

- | | | |
|---------------------------------|---------------------------------|-----------------------------|
| 1. Drive and Caster Wheels | 4. Motor/Pump/Reservoir Unit | 7. Platform Control Console |
| 2. Base Frame | 5. Batteries (Open Cover Doors) | 8. Ground Control Console |
| 3. Manual Descent Control Valve | 6. Platform Assembly | 9. Mast Assembly |

2.5 FUNCTION CHECK

Once the “Walk-Around” Inspection is complete, perform a function check of all systems in an area free of overhead and ground level obstructions. Refer to Section 3 for more specific operating instructions.

WARNING

IF THE MACHINE DOES NOT OPERATE PROPERLY, TURN OFF THE MACHINE IMMEDIATELY! REPORT THE PROBLEM TO THE PROPER MAINTENANCE PERSONNEL. DO NOT OPERATE THE MACHINE UNTIL IT IS DECLARED SAFE FOR OPERATION.

Perform a Function Check as follows:

1. **From the ground controls with no load in the platform:**
 - a. Operate ground control functions, platform lift up and lift down.

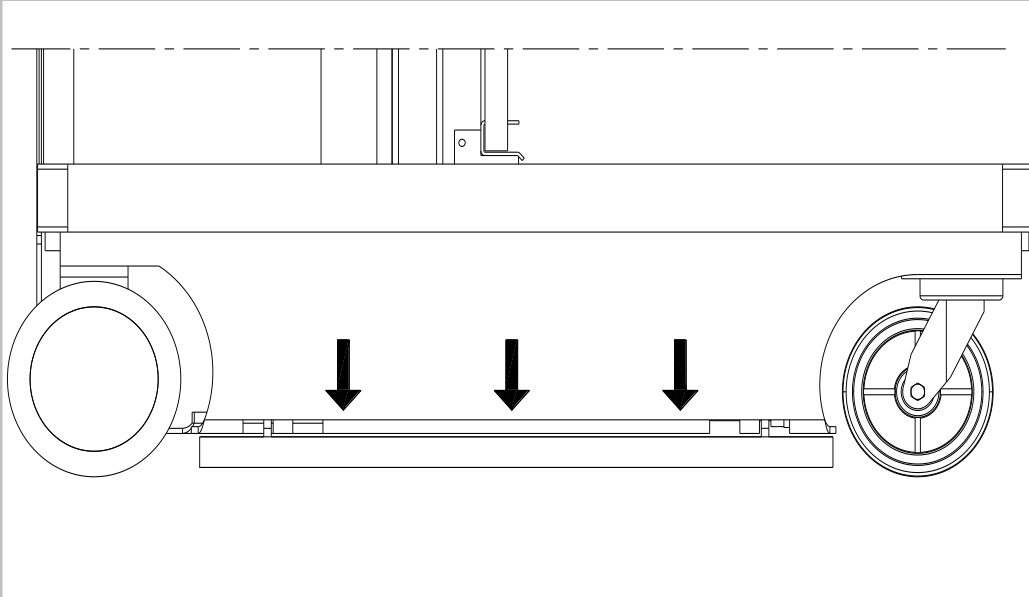

NOTE: Ensure Pot-Hole-Protection device is fully engaged (both bars down) when the platform is elevated.

b. Ensure that all machine functions are disabled when the Emergency Stop Button is activated.

c. Check Manual Control valve is operating properly.

2. **From the platform control console:**

a. Ensure that the control console is properly mounted and secure.

b. Raise and lower platform 2 ft. to 3 ft. (.61m to .92m) several times. Check for smooth elevation and lowering of platform.

c. Operate all functions and check all limit and cutout switches.

d. Ensure that all machine functions are disabled when the Emergency Stop Button is activated.

3. **With platform in the transport (stowed) position:**

a. Drive the machine on a grade, not to exceed the rated grade ability, and stop to ensure the brakes hold.

b. Check the 1.5 degree tilt sensor alarm to ensure proper operation.

SECTION 3. MACHINE CONTROLS, INDICATORS AND OPERATION

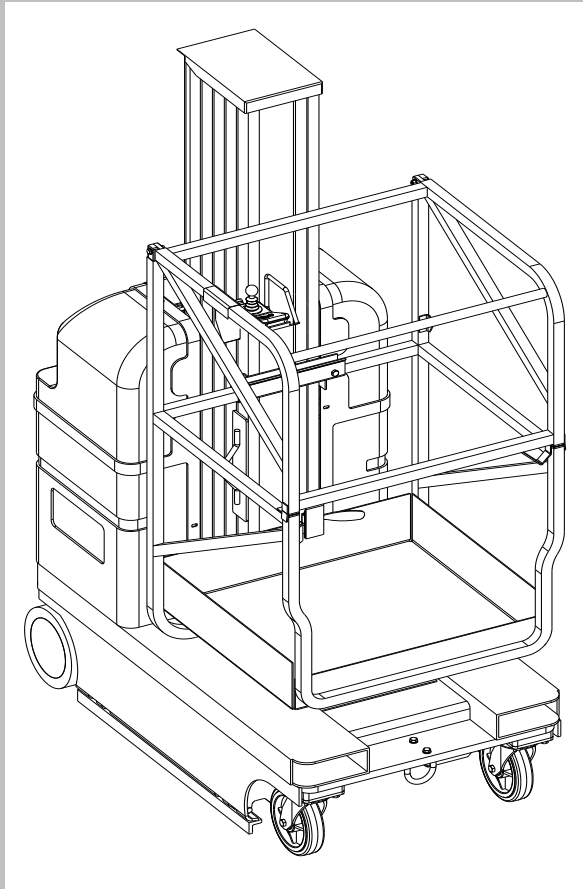

Table 3-1 AMWP-Machine Operating Specifications

	AMWP6-1000	AMWP7.5-1000	AMWP7.5-2000	AMWP9-2000
Maximum Occupants:	1		1~2	
Maximum Work Load (Capacity): Standard: Extendible:	150kg	125kg	200kg	150kg
	125kg	100kg	175kg	125kg
Maximum Travel Grade (Grade ability):	15-20%			
Maximum Travel Grade (Side Slope):(Platform STOWED ONLY)	5°			
Maximum Height (Platform Stowed)	198cm			
Maximum Vertical Platform Height:	6m	7.5m	7.5m	9m
Maximum Wheel Load (Per Wheel):	360kg			
Maximum Drive Speeds (Operator Variable):	0.6.8-4 km/h			
Max. Platform Speeds (w/Max. Load): Platform Up: Platform Down:	27-36 sec.	39-49 sec	62-73 sec	82-93 sec
	30-35 sec.	40-45 sec	43-46 sec	53-56 sec
Gross Machine Weight (Standard Equipment/Platform Empty): (Extendible Equipment/Platform Empty):				
	850kg	880kg	1100kg	1250kg
	900kg	930kg	1160kg	1310kg

3.1 GENERAL

IMPORTANT

THE MANUFACTURER HAS DIRECT CONTROL OVER MACHINE APPLICATION AND OPERATION. THE USER AND OPERATOR ARE RESPONSIBLE FOR CONFORMING WITH GOOD SAFETY PRACTICES.

This section provides the necessary information needed to understand control function and operation.

3.2 MACHINE DESCRIPTION

The AMWP Model Lifts are electric self-propelled machines with an aerial work platform mounted to an elevating aluminum mast mechanism. The personnel lift's intended purpose is to personnel access to areas above ground level.

The primary control station is located in the platform. From the Platform Control Console the operator can drive the machine and raise or lower the platform.

The controls of the programmable Ground Control Station are to be used during machine power-up, machine maintenance or in case of emergency should the operator in the platform be unable to lower the platform.

Vibrations emitted by these machines are not hazardous to an operator working in the platform.

The continuous A-Weighted sound pressure level at the work platform is less than 70db (A).

3.3 MACHINE OPERATION

Getting Started

The following control conditions must be met before the machine can be operated from either the Ground or Platform Controls.

- The batteries contain enough voltage to operate the machine.
- The Main Power Selector Switch on the Ground Control Station must be set for either Ground Control Mode or Platform Control Mode.
- Both Emergency Stop Switches, one on the Ground Control Station the other on the Platform Control Console must be in the RESET position.
- If equipped, the On/Off Key Switch on the Platform Console must be set to the ON position.

3.4 BATTERY CHARGING

AMWP machines are equipped with an AC voltage input/DC voltage output battery charger. The charger automatically terminates charging when the batteries reach full capacity.

NOTE: The machine's platform drive function is disabled when the battery charger is plugged into an AC receptacle.

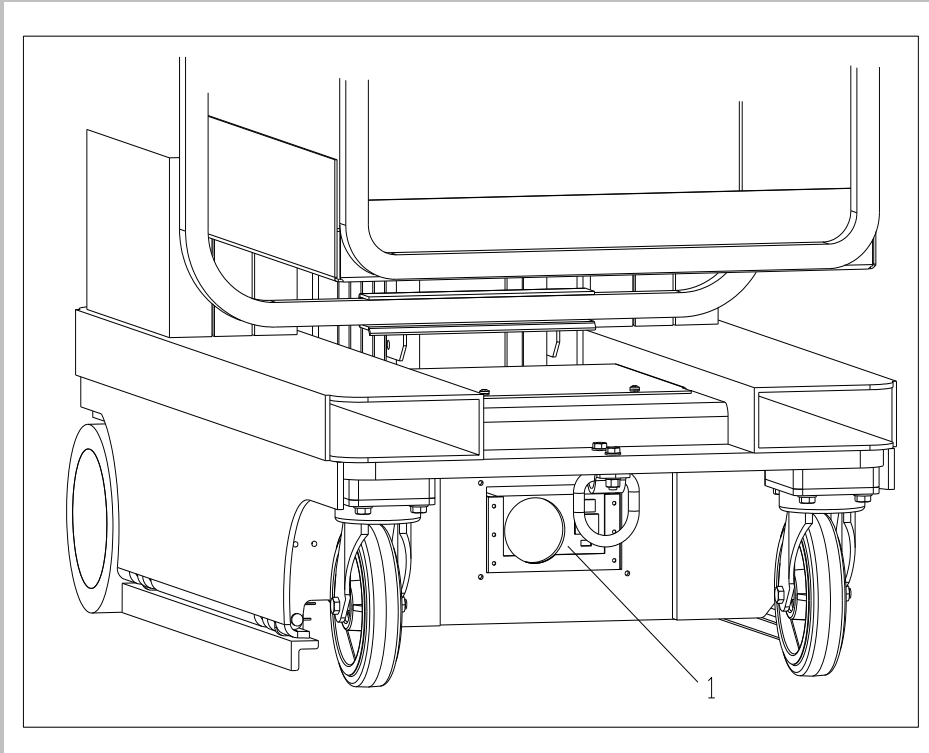
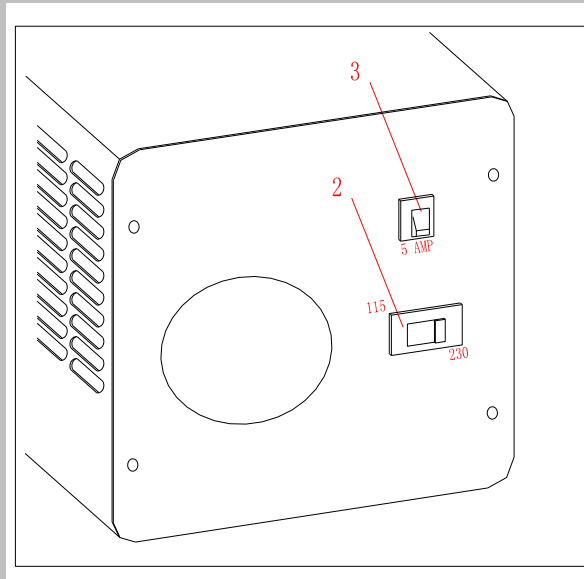

Figure 3-1. Battery Charger Location.

Battery Charger



Battery Charger Front Panel

2. ON/OFF switch

3. AC Input Voltage Selector

Battery Low Voltage Warning Indicators

The Platform Control Console and Ground Control Station indicate battery low voltage at three (3) Warning Levels.

Table 3-2. Battery Low Voltage Warning Indicators.

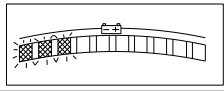
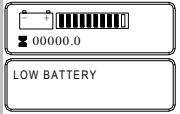
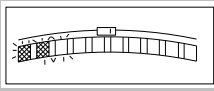
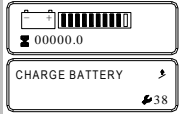
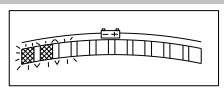
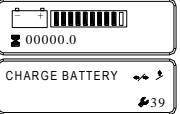
IMPORTANT: The 3 Levels of Battery Low Voltage Warning indication will activate on Ground Control Modules and platform control console. Machines must follow the indicator guidelines and battery charging cycles to maximize battery life.				
WARNING LEVEL	INDICATOR LOCATION		RESULT	ACTION REQUIRED TO CLEAR FAULT
	PLATFORM CONTROL LED	GROUND CONTROL LCD		
LEVEL-1			<ul style="list-style-type: none"> • 3 LEDs/BARS flashing • with an audible beep. • Machine will Operate-No Control • Functions Locked Out. 	Charge batteries to a level of four (4) LEDs/BARS or more before operating.
LEVEL-2			<ul style="list-style-type: none"> • 2 LEDs/BARS flashing • with an audible beep. • Platform Lift-UP • Function is Locked Out. 	Charge batteries for a minimum of four (4) Continuous hours or eight (8) LEDs/BARS lit before Operating. (a)
LEVEL-3			<ul style="list-style-type: none"> • 1 LED/BAR Flashing with an audible beep. • Drive and Platform • Lift-UP Functions • Locked Out. 	Charge batteries for a minimum of four (4) continuous hours or eight (8) LEDs/BARS lit before operating.(a)
NOTE: (a) To maximize battery life, it is recommended that the factory supplied batteries be charged continuously for a minimum of 4 hours or until 8 bars are lit on the ground station LCD Display before operating the machine. When drained to Warning Level 2 or 3, batteries must be charged until 8 bars are lit on the ground station LCD display to clear the fault code.				

To Charge Batteries

1. Park machine in a well ventilated area near an AC voltage electrical outlet.
2. Check the AC voltage selector switch on front of the battery charger is set to correct local AC voltage.

NOTE: The batteries on AMWP machines require approximately five (5) hours to fully charge when drained to LOW BATTERY VOLTAGE warning on the Ground Control Module LCD display.

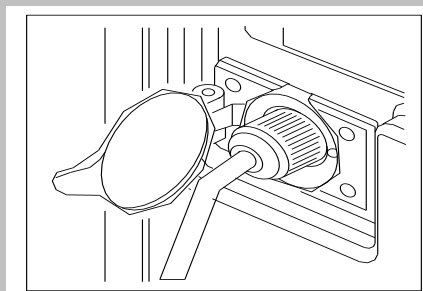

3. Plug a heavy duty AC extension cord into the Charger AC Input Receptacle on the center rear cover of the machine.

Battery Charging Status Indicators

The battery charging status indicators are located just on the left of the Charger AC input receptacle on the center cover section at the rear of the machine.(See Figure 3-2.)

When first plugged in, the charger runs through a self-diagnostic test, lighting the LEDs in sequence, then charging will begin.

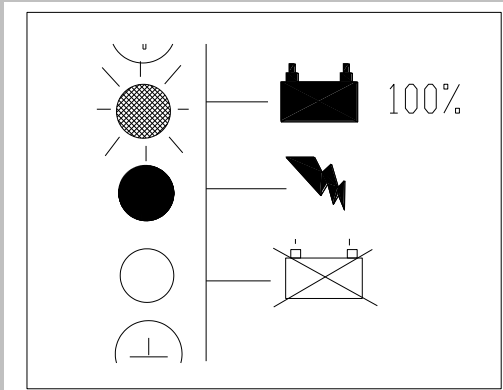

CHARGE COMPLETE

GREEN (TOP) LED ON
100% Complete

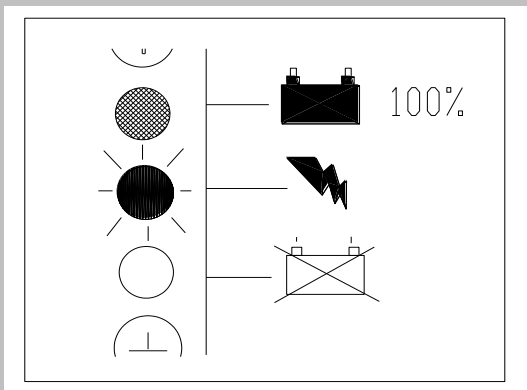

CHARGING

AMBER (MIDDLE) LED ON
Charging incomplete

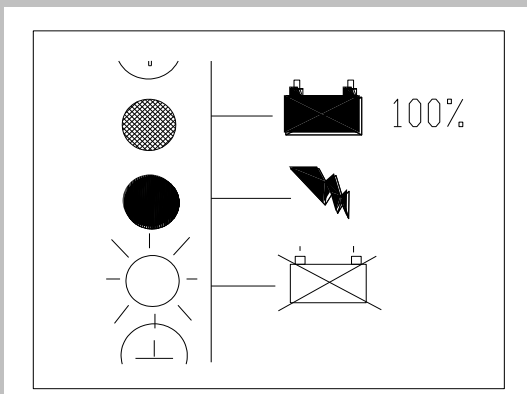

CHARGING PROBLEM

RED (BOTTOM) LED ON
Consult Troubleshooting Section
of the Service Manual

3.5 GROUND CONTROL STATION-OPERATION

(See Figure 3-2.)

Main Power Selector Switch

Set the Main Power Selector Switch to Ground Control Mode at the Ground Control Station

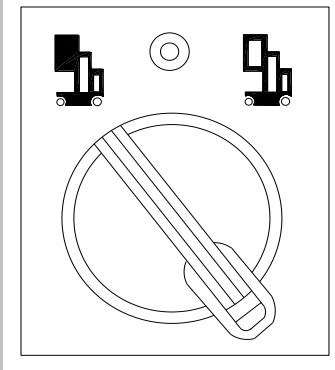

Emergency Stop/Shut Down Button

POWER OFF

PUSH IN-To Engage
Emergency Stop

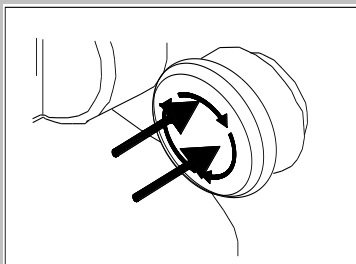

POWER ON

TURN CLOCKWISE and RELEASE-To Reset
Emergency Stop

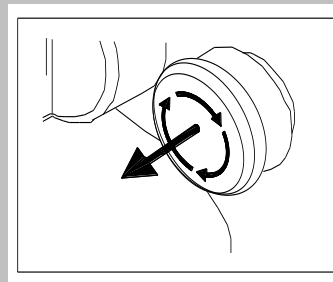

Brake Release Button

PUSH and RELEASE-TO DISENGAGE Brakes
PUSH and RELEASE AGAIN-TO ENGAGE Brakes

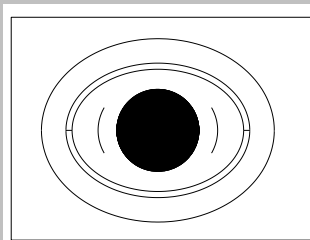

NOTE: The brakes only DISENGAGE (electrically) when the joystick control is moved off center during driving or are manually DISENGAGED (electrically) using the Brake Release Button.

If the machine's batteries are completely depleted of electrical charge the brakes cannot be released manually.

CAUTION

DO NOT MANUALLY DISENGAGE THE BRAKES UNLESS MACHINE IS SETTING ON A LEVEL SURFACE OR MACHINE IS FULLY RESTRAINED.

Platform Up

PUSH IN-TO ELEVATE Platform

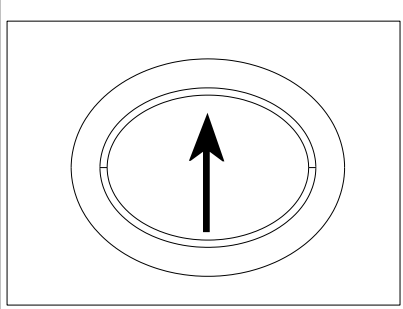

RELEASE-TO STOP ELEVATING

Platform Down

PUSH IN-TO LOWER Platform

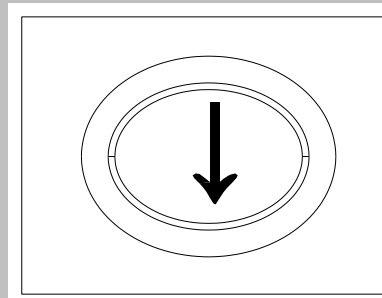

RELEASE- TO STOP LOWERING

Manual Descent Control Valve

DRAW-OUT TO LOWER Platform

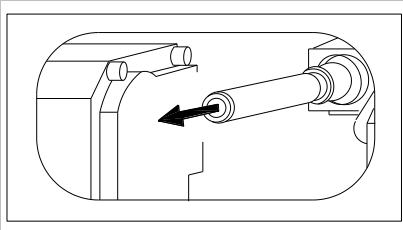

RELEASE TO -STOP Platform Descent

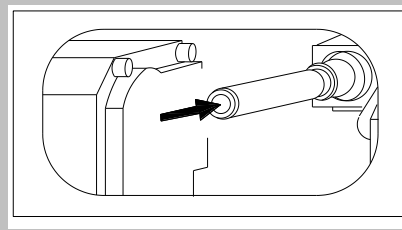

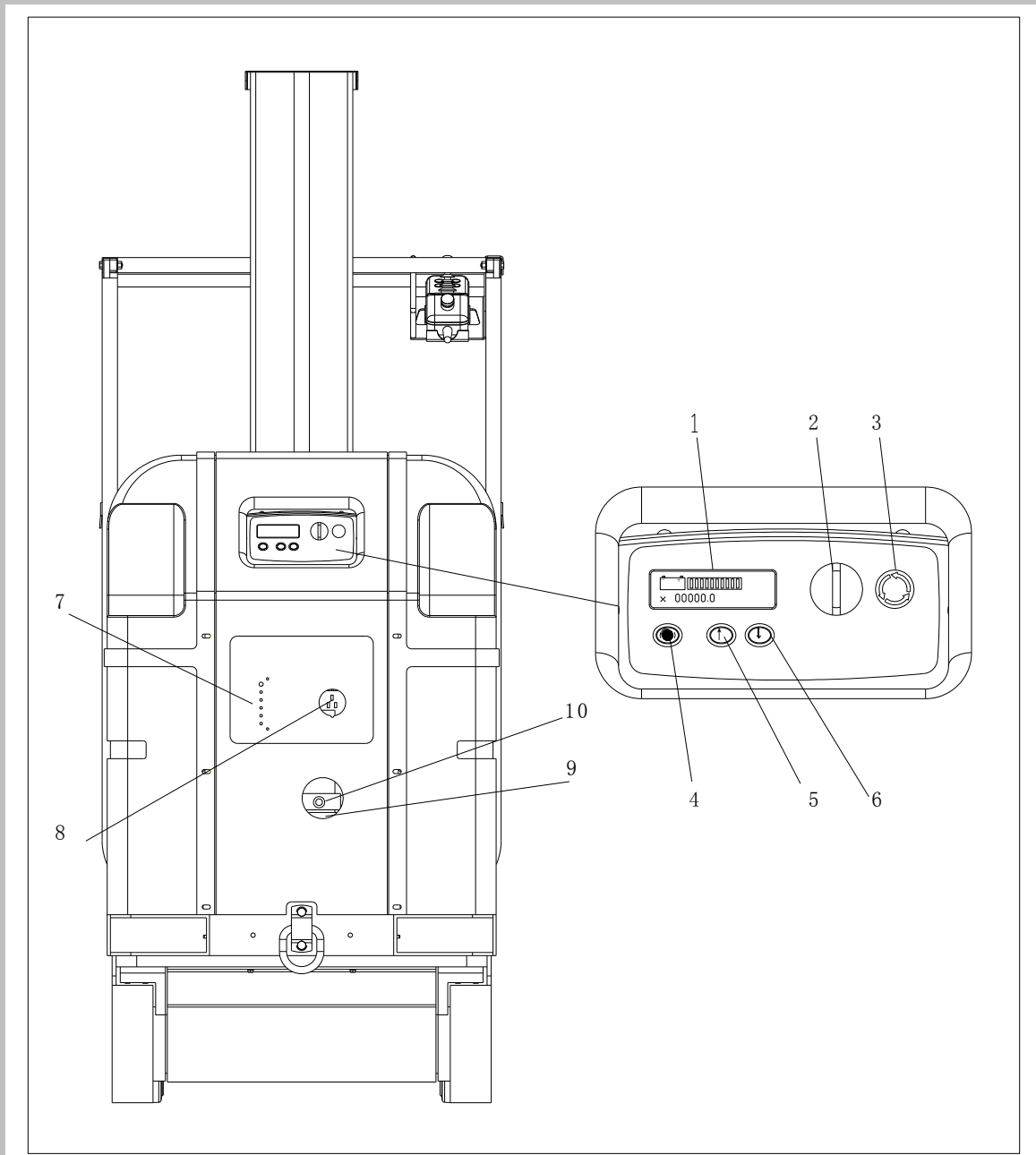
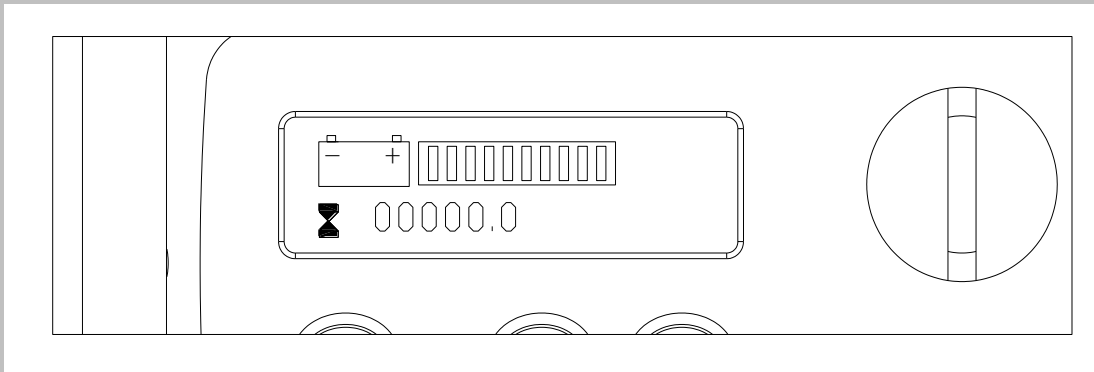
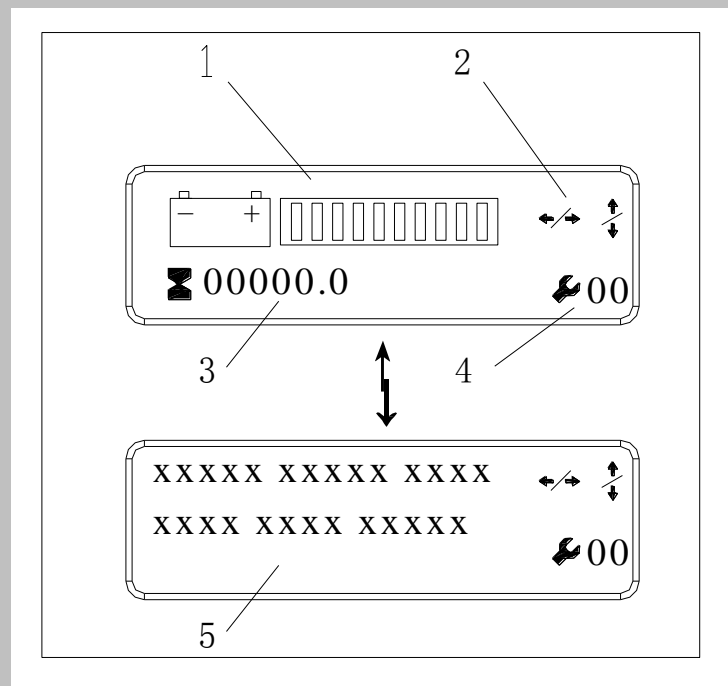

Figure 3-2. Ground Control Station. (Machine Rear View)

- | | | |
|-------------------------------|---------------------------------------|----------------------------------|
| 1. Machine Status LCD Display | 5. Platform Up | 9. Hydraulic Oil Reservoir |
| 2. Main Power Selector Switch | 6. Platform Down | 10. Manual Descent Control Valve |
| 3. Emergency Stop | 7. Battery Charging Status Indicators | |
| 4. Brake Release | 8. Charger A/C Input Receptacle | |

Machine Status LCD Display

At power-up and during operation the LCD display on the Ground Control Module displays the current machine operating status. The following illustration explains the symbol indications.

**LCD Display Symbols**

1. Battery Charge Indicator (BCI)
2. Function Display or Function Disabled Indicators
3. Hour Meter Display
4. Fault Code Indicator
5. Fault Text Message Display (a)

Note: (a) When a Fault Code is indicated the LCD screen will alternate between the text and symbol display modes.

In the LCD Display Symbols illustration item (2), the Function Display or Function Disabled Indicators will vary as shown following:

DRIVE Disabled

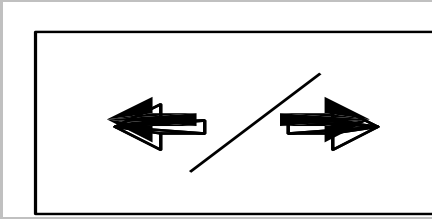

LIFT UP Disabled

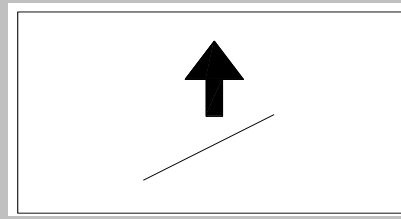

LIFT DOWN Disabled

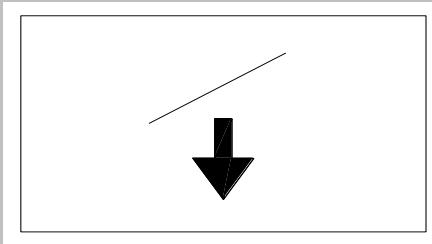

Both LIFT UP and LIFT DOWN Disabled

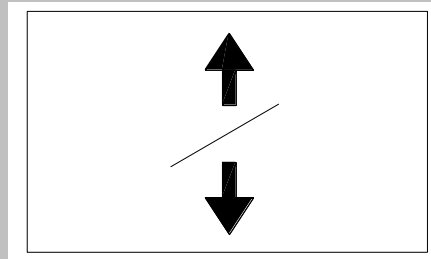

Drive Speed Cup-Back (Turtle) Mode Engaged (When Platform is Elevated)

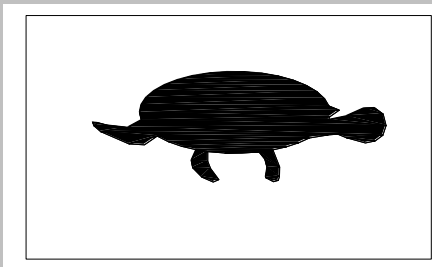

Battery Charger (AC) Plugged In

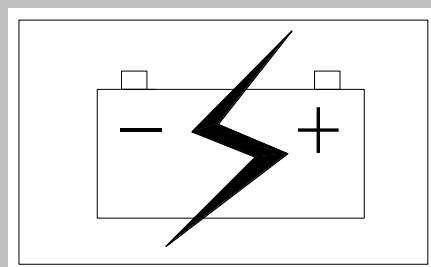

LCD Display Fault Conditions

Table 3-3, LCD Display – Operating Fault Conditions show common LCD display Fault indications which may occur during operation and are usually caused by either an error in machine operation or a work area condition. These fault conditions can usually be corrected by the operator and do not require a qualified mechanic to repair.

IMPORTANT

AFTER A FAULT CONDITION IS CORRECTED THE MACHINE POWER MAY NEED TO BE RECYCLED TO RESET THE GROUND CONTROL STATION.

Table 3-3. LCD Display – Operating Fault Conditions

Fault code	Description of fault	Conditions to check
01	Low Battery Voltage	Battery cable ends loose or corroded at battery posts. Charger DC output wires from charger to batteries damaged or disconnected.
02	Left PHP Bar – Up	Obstruction under Left pothole bar. Obstruction around the actuator assembly at the base of the mast.
03	Right PHP Bar – Up	Obstruction under Right pothole bar. Obstruction around the actuator assembly at the base of the mast.
04	Tilt Condition	If machine is on a tilt of more than the angle set in either or both the X or Y direction, this is normal operation. When the lift platform is raised then drive and lifting are disabled when tilt is detected. Check if Ground Station is mounted securely to the mast support column.
05	Obstruction Sensor System- No communication with Ground Module	Is machine equipped with an Obstruction Sensor System? Check all cabling from the OSS module is undamaged.
06	Reserved	
07	Left Drive Motor – Disconnected	Check left drive motor M1 connector at the Traction Module for secure and proper connection.
08	Right Drive Motor – Disconnected	Check right drive motor M2 connector at the Traction Module for secure and proper connection.
09	Left Brake – Disconnected	Check left drive motor M1 connector at the Traction Module for secure and proper connection.
10	Right Brake – Disconnected	Check right drive motor M2 connector at the Traction Module for secure and proper connection.
11	Left Drive Motor – Short Circuit	Wiring harness from motor M1 connector on Traction module to left drive motor for damage.
12	Right Motor – Short Circuit	Wiring harness from motor M2 connector on Traction module to right drive motor for damage.
13	Traction Module – In Foldback	Machine is operating on a continuous grade or rough terrain
14	Pump Motor – Disconnected	Check the positive and negative cables from the Ground Module to the Pump Motor studs for loose or corroded connections.
15	Lift Down Valve- Disconnected	Inspect wire terminals on the lift down valve wiring harness or a damaged lift down valve coil.
16	Lift Down Valve – Short Circuit	Damaged wiring in the lift down valve wiring harness or a damaged lift down valve coil.
17	Ground Module – In Over temperature	Pump is not being permanently driven Check heat sinking of Ground Module
18	Alarm – Short Circuit	Damaged wiring in the alarm wiring harness or a damaged alarm.
19	Alarm – Disconnected	Damaged wiring in the alarm wiring harness or a damaged alarm. Activate a function to check if alarm sounds
20	Beacon – Short Circuit	Damaged wiring in the beacon wiring harness or a damaged beacon unit.
21	Beacon – Disconnected	Is machine equipped with flashing beacon light.
22	Horn – Short Circuit	Damaged wiring in the horn wiring harness or a damaged horn unit.
23	Horn - Disconnected	Is machine connected with a horn.
24	Auxiliary 1 Circuit – Short Circuit	Damaged wiring in the Auxiliary 1 Component wiring harness or a damaged component.
25	Auxiliary 1Circuit- Disconnected	Is machine equipped with a component on the Auxiliary 1 circuit.
26	Auxiliary 2 Circuit – Short Circuit	Damaged wiring in the Auxiliary 2 Component wiring harness or a damaged component.
27	Auxiliary 2Circuit- Disconnected	Is machine equipped with a component on the Auxiliary 2 circuit
28	Reserved	
29	Reserved	

30	Traction Module-No communication with Ground Module	Check if the communications cable connections, P5 connector on the Ground Station and the round plug on the Traction Module are seated properly in their sockets at each end. Check the positive and negative power cable connections from the Ground Station to the Traction Module are tight and secure at both ends.
31	Platform Control Console – No communication with the Ground Module	Check the harness connection at the P4 connector on the Ground Station and the harness connection at the other end on the Platform Junction Box.
32	Pump Motor – Over Current	Platform overload condition. Obstruction in mast system. Pump positive and negative connections are secure and undamaged. Crushed or kinked hydraulic lines. Hydraulic leaks.
33	Both PHP Bars - Up	Obstruction under left or right pothole bar. Obstruction around the actuator assembly at the base of the mast.
34	Aux 1 - Inhibit	Auxiliary 1 switch input is active.
36	Aux 2 - Inhibit	Auxiliary 2 switch input is active.
49	Aux 3 - Inhibit	Auxiliary 3 switch input is active.
50	Aux 4 - Inhibit	Auxiliary 4 switch input is active.
100 - 199	Ground Station – Fault Condition	Battery and harness connectors are secure and undamaged on the Ground Module. Batteries have sufficient charge. Confirm that the static ground strap attached under base frame is secure and undamaged.
200 - 299	Platform Control Console – Fault Condition	Damage to Platform Control Console wiring harness. Check connections from the Platform Control Console down to the Ground Module. Confirm that the static ground strap attached under base frame is secure and undamaged.
300 – 399	Traction Module – Fault Condition	Damage to Traction Module wiring harness. Confirm that the static ground strap attached under base frame is secure and undamaged.
<p>NOTE: The fault conditions shown above are fault conditions, which the Operator may be able to resolve. Should a fault occur and be displayed on the LCD screen which cannot be corrected at the Operator's level, the problem must be referred to a qualified mechanic. A complete table of Fault Codes is listed in the Trouble Shooting Section of the Operation and Safty Manual..</p>		

3.6 GROUND CONTROL STATION – PROGRAMMING

General

The AMWP machine Ground Control Station allows on-board programming of various component and control function personality settings.

Programming may be required under circumstances such as:

- Optional equipment has been added to the machine in the field and a function must be enabled before operation.
- Customizing the machine to fit a specific application, such as changing the LCD display language.

Programming Levels

There is one (1) password protected programming level available to the Operator:

- **Level –3:** Operator's Settings
Level –3 Password: 23456

Operator Programming Mode

In the Operator Level Programming Mode the following items are shown on the main menu (See Table 3-4 for Setting Range and Default Factory Setting):

- Tilt Sensor
- Program
- **Tilt Sensor**
Allows viewing current tilt sensor individual X and Y direction degree reading.
- **Program**
Allows programming of the items shown in Table 3-4, the following is a brief explanation of each programming item.

NOTE: There are two production modules available at this time, one for North/South American and European languages, and one for Asian languages. All programmable items between these modules are identical with the exception of language selection.

- **Back To Main** – When selected, will return to main level menu.
- **Set Language** – Selects the language that text on the LCD screen will be displayed.
- **Set Sleep Time**- Allows setting the length of time the machine will remain powered up without control input before powering itself down.
- **Set Polarity of Keypad Code** – Turns on or off the Programmable Security Lock switch circuit, if equipped.
- **Enable Detection of Horn Open Circuit** – Enables horn electrical circuit to be turned on (YES) or off (NO) if machine is equipped with a horn.
- **Enable Detection of Beacon Open Circuit** – Enables mast/base beacon strobe electrical circuits to be turned on (YES) or off (NO) if machine is equipped with either or both beacon strobes.
- **Forward Alarm Disable** – When turned on (YES) will disable the alarm when driving forward.

Table 3-4. AMWP Ground Control Station – Level 3 – Programmable Settings and Factory Presets.

Level-3: Operator Programmable Settings		On LCD Display: YES= √ HIGH= ↑ NO= × LOW= ↓	
LEVEL	PROGRAMMABLE ITEM	FACTORY PRESET	SETTING RANGE
3	Back to Main	—	Return to Main Menu
3	Set Language NOTE: There are two production modules available at this time, one for North/South American and European Languages, and one for Asian Languages.	1	1- English 6- Italian 2- German 7- Swedish 3- Dutch 8- Brazilian Portuguese 4- French 9- Finnish 5- Spanish
		2	1- English 3-Japanese 2-Chinese
3	Set Sleep Time	5 MINS	0-60 MINS
3	Set Polarity of the Keypad Code	LOW	HIGH/LOW
3	Enable Detection of Horn Open Circuit	NO (a)	YES/NO
3	Enable Detection of Beacon Open Circuit	NO (a)	YES/NO
3	Forward Alarm Disable	NO	YES/NO
3	OSS Diagnostics	NO	YES/NO

Notes: (a) AMWP Models this feature is standard equipment and preset to YES at factory.

Activating Programming Mode

NOTE: If machine does not power up, check that both the Ground Control Station – Emergency Stop Button, and the Platform Control Console – Emergency Stop Button, are in the RESET position.

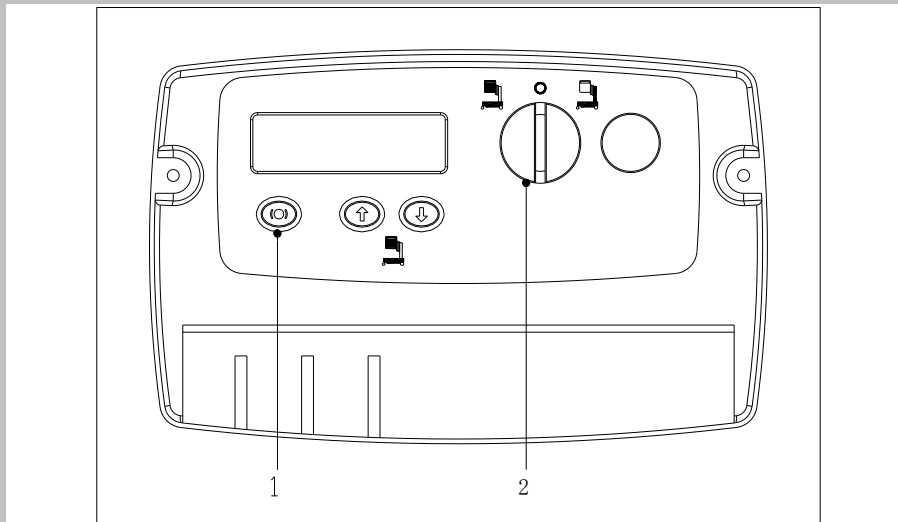

1. With machine power OFF, press and hold the Brake Release Button (1) on the Ground Control Station.
2. While holding the Brake Release Button in, power machine up by turning the Main Power Selector Switch (2), to either the Ground Control or Platform Control Mode.
3. Release the Brake Release Button (1) after machine is powered up. The LCD display should now display five zeros, one with a box around. Continue to next step Entering Password.

Entering Password

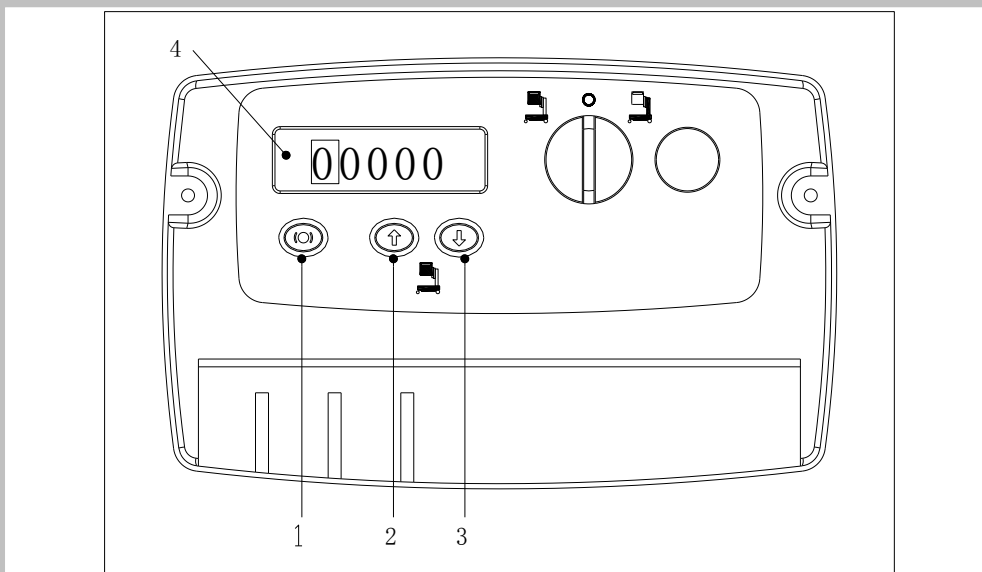

1. The Brake Release button (1) moves the box from left to right to select which digit to change.
2. Platform UP button (2) increases the numerical digit.
3. Platform DOWN button (3) decreases the numerical digit.
4. Change all five digits (4) to match password level, then press the Brake Release button (1) again.

Programming Mode Selection

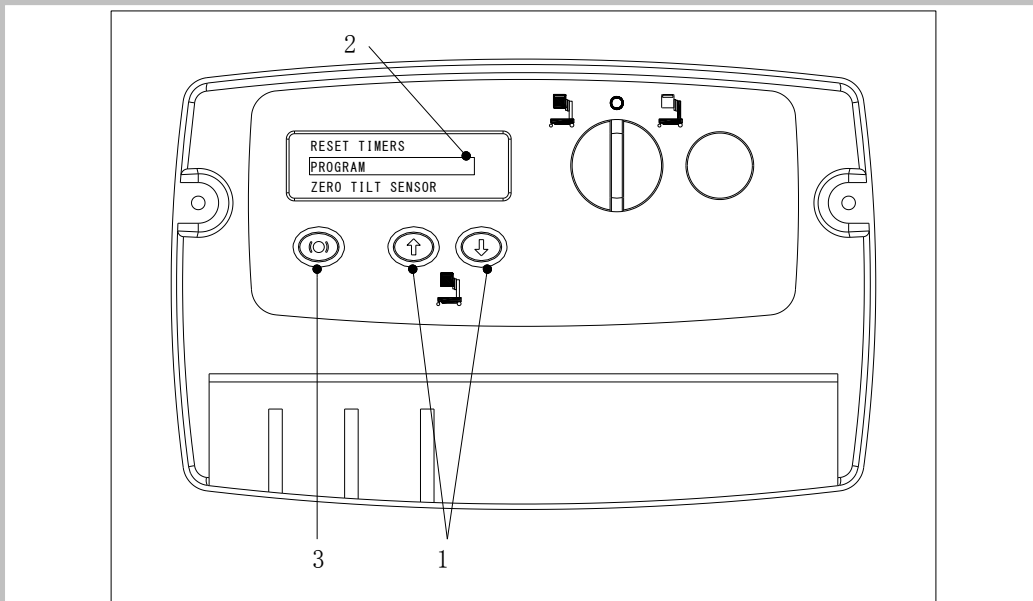

1. Use Platform UP/DOWN buttons (1) to move the selection box (2) up or down to select item to program.
2. Press the Brake Release button (3) to enter selected mode then move on to Selecting Programmable Item to Adjust.

Selecting Programmable Item to Adjust

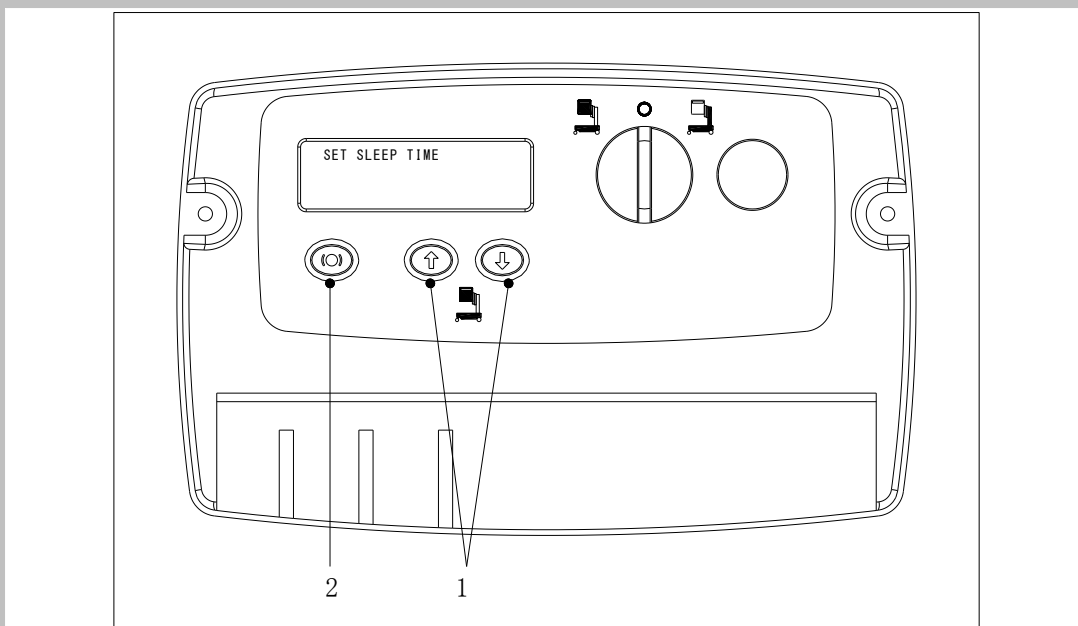

1. Use the Platform UP/DOWN buttons (1) to scroll through the list of programmable items available to your programming level.
2. Once a programmable item to be adjusted is selected, press the Brake Release button (2) to enter that settings' adjustment mode.

Adjusting Programmable Setting

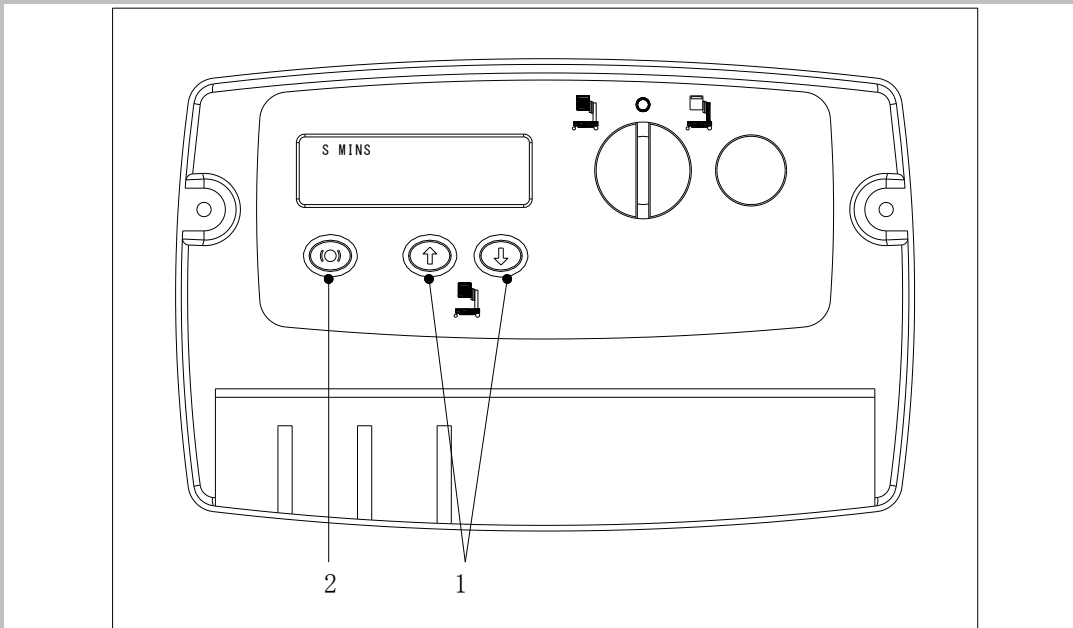

1. Adjust the programmable setting using the platform UP/DOWN buttons (1), see Table 3-4 for range of settings for that item.
2. Once parameter is set for the programmable item, press the Brake Release button (2), this will enter the parameter and return you to the Programmable Settings Menu.

TO EXIT Programming Mode after adjusting programmable settings, power machine down with either the Main Power Selector Switch or Emergency Stop Button.

3.7 PLATFORM CONTROL CONSOLE OPERATION

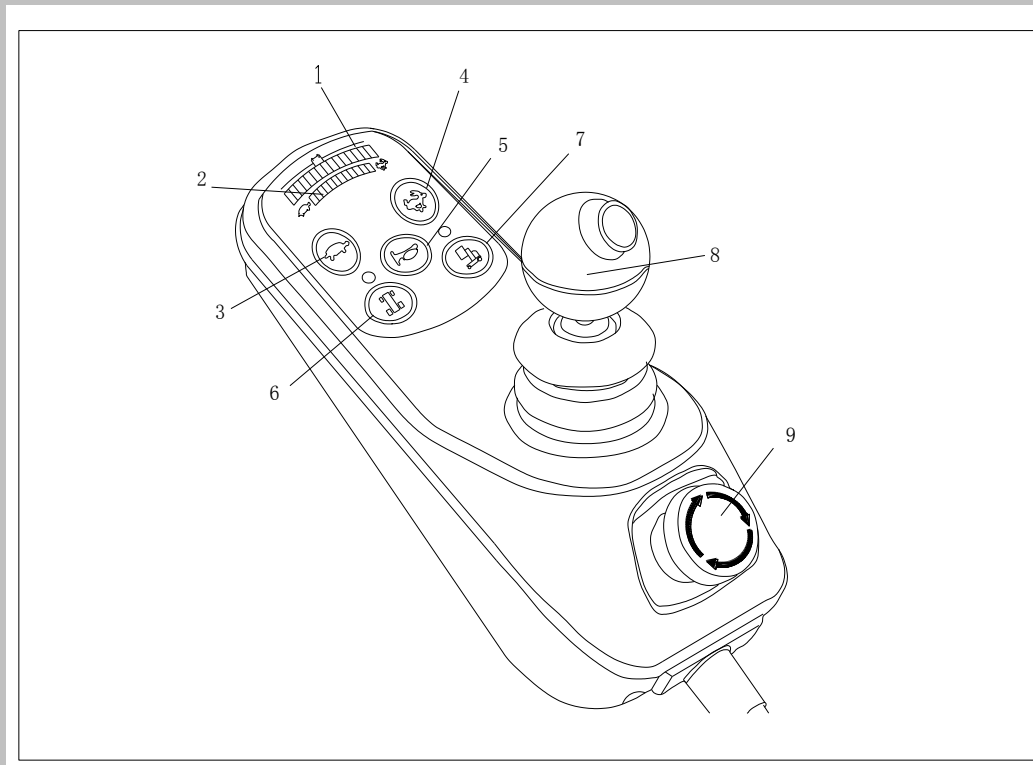
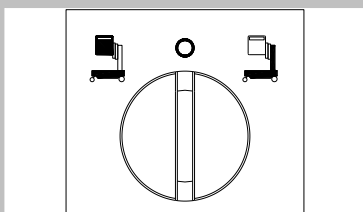

Figure 3-3. Platform Control Console

- | | | |
|-------------------------------------|------------------------------|--------------------------------|
| 1. Battery Charge/Fault Code (LEDs) | 3. Decrease Max. Drive Speed | 7. Platform Function (Enable) |
| 2. Max. Drive Speed Setting (LEDs) | 4. Increase Max. Drive Speed | 8. Joystick with Enable Button |
| | 5. Horn | 9. Emergency Stop |
| | 6. Drive Function (Enable) | |

At Ground Control Station



Set the Main Power Selector Switch to Platform Control Mode at the Ground Control Station. (See Figure 3-2.)

Emergency Stop/Shut-Down Button

POWER-OFF
 PUSH IN-TO ENGAGE
 Emergency Stop

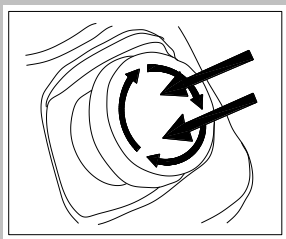

POWER ON
 TURN CLOCKWISE and RELEASE-TO RESET
 Emergency Stop

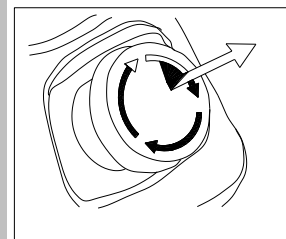

Battery Charge/Fault Code LED Indicator

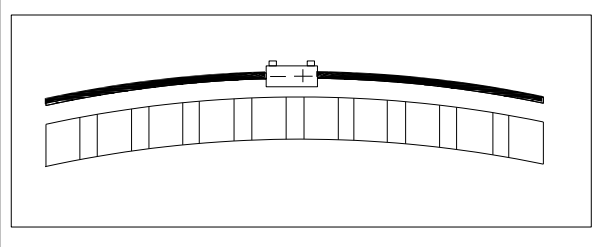

On normal power-up and operation this series of LEDs visually indicates the amount of charge left in the batteries.

- (+) GREEN LEDs lit indicate maximum charge.
- (-) RED LED's lit indicate minimum charge remaining.
- The number of LEDs lit will change depending on the level of charge in the batteries.

If battery voltage falls below 16.8 volts a fault condition will occur and the machine will stop operating. The batteries will need recharged.

NOTE: LED Fault Code indications are in Table 3-3, LCD Display – Operating Fault Conditions, this section of the manual.

Driving Machine

WARNING

WHEN DRIVING WITH PLATFORM LOWERED, DO NOT ATTEMPT TO DRIVE MACHINE UP A RAMP (GRADE) OF GREATER THAN TWENTY PER CENT (20%), AS TIPPING COULD OCCUR.

POINT & GO®

The Joystick can be moved in any direction off center.

Drive Power is applied proportionally the further the Joystick is moved off center.

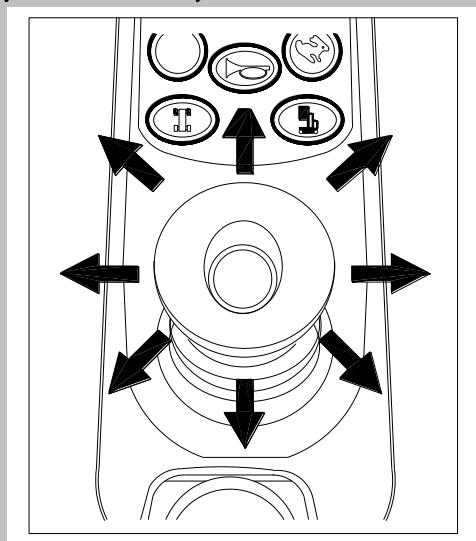

1. Enter the platform.
2. PRESS and RELEASE the Drive Function Button. The flashing LED indicates the function is active. The function remains active 3 to 4 seconds.

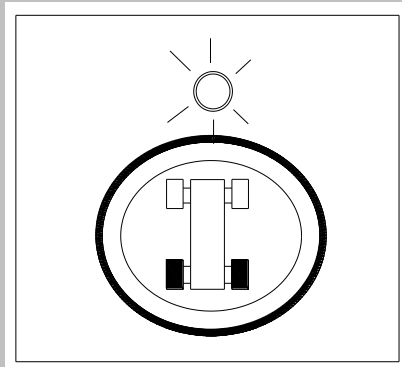

3. While the Drive Function is active. PRESS and HOLD the enable button on side the joystick.

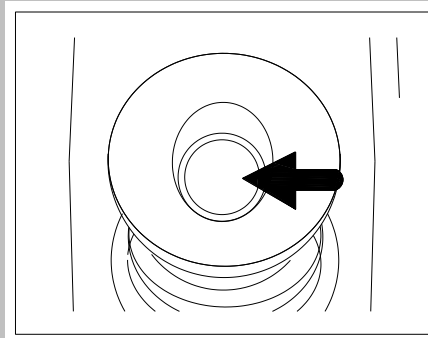

4. Move the joystick the desired direction of travel. TO STOP the machine return the joystick back to center.

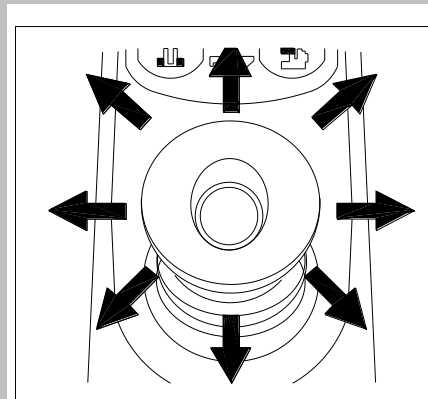

Adjusting Maximum Drive Speed Control

NOTE: When the platform is elevated the maximum drive speed is cut-back to 1/4th the speed when the platform is fully lowered. The Ground Control Module- LCD screen will display a turtle when in this mode, see Machine LCD Status Display in this section of the manual.

Maximum Drive Speed Indicator

Indicates current Maximum Drive Speed Setting. Slow to Fast.

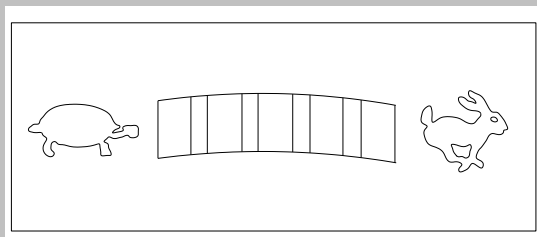

1. Each Press of this button will reduce the Maximum Drive Speed allowed. (LESS LEDs Lit.)

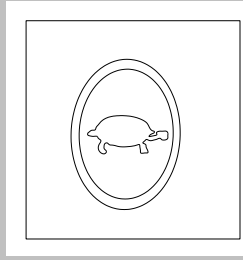

2. Each Press of this button will increase the Maximum Drive Speed allowed. (MORE LEDs Lit.)

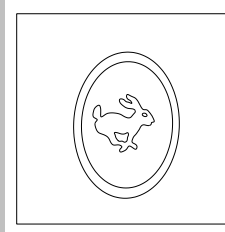

Elevating/Lowering the Platform

WARNING

IF THE TILT ALARM HAS BEEN ACTIVATED, THE PLATFORM WILL NOT ELEVATE. ALSO IF THE TILT ALARM HAS BEEN ACTIVATED WHEN THE PLATFORM IS ELEVATED, THE DRIVE FUNCTION WILL BE DISABLED UNTIL THE PLATFORM IS COMPLETELY LOWERED.

1. Drive the machine to the area where overhead work is to be performed and position the machine into its approximate work position.
2. PRESS and RELEASE the Platform Function Button. The flashing LED indicates the function is active and will remain active 3 to 4 seconds.

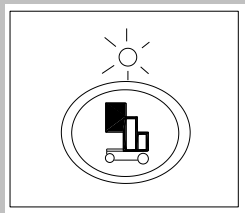

3. While the Platform Function is active. PRESS and HOLD the Enable Button on side the Joystick.

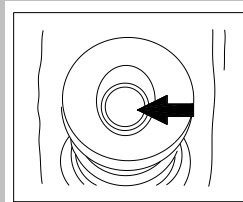

4. Push the Joystick FORWARD from center TO ELEVATE the Platform.
TO STOP platform movement return the joystick back to center.
Pull the Joystick BACK from center TO LOWER the Platform.

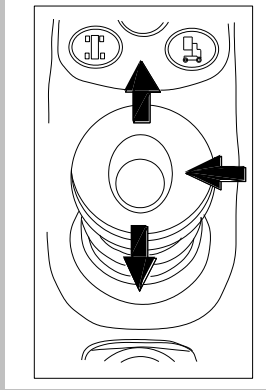

5. If necessary, reposition (drive) lift using platform controller joystick to bring work object within reach.

3.8 PARKING MACHINE

1. Drive machine to a well-protected and well-ventilated area.
2. Ensure the platform is fully lowered, turn the main power selector switch to the OFF position (centered).

NOTE: If required, charge batteries in preparation for next workday.

3.9 PLATFORM CONFIGURATIONS

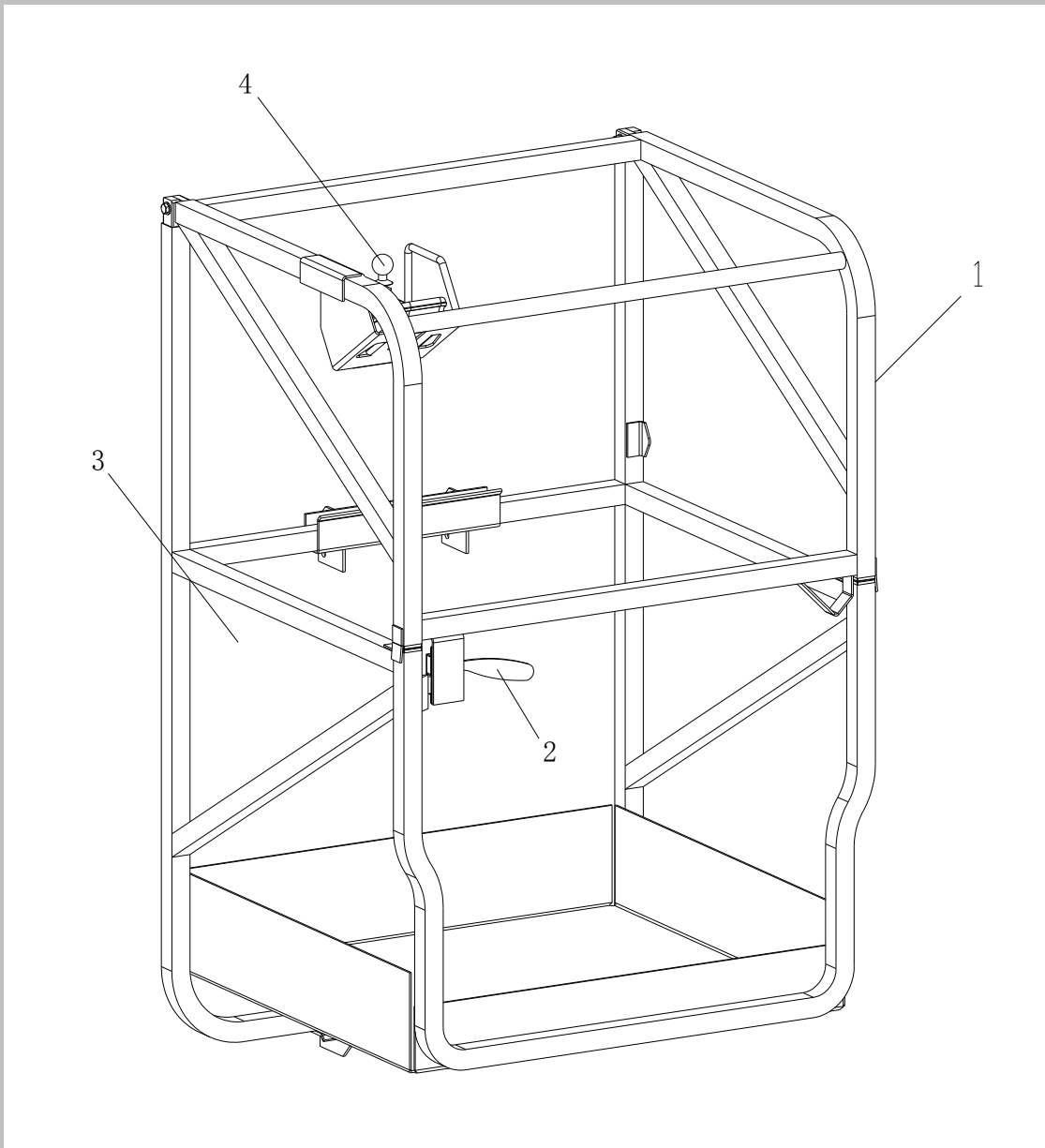

STANDARD PLATFORM (AMWP)

Model	Max. Capacity
AMWP6-1000	150kg
AMWP7.5-1000	125kg
AMWP7.5-2000	200kg
AMWP9-2000	150kg

1. Gullwing Entry Gate	3. Lanyard Attach Point (on mast)
2. Entry Gate Latch	4. Platform Control Console

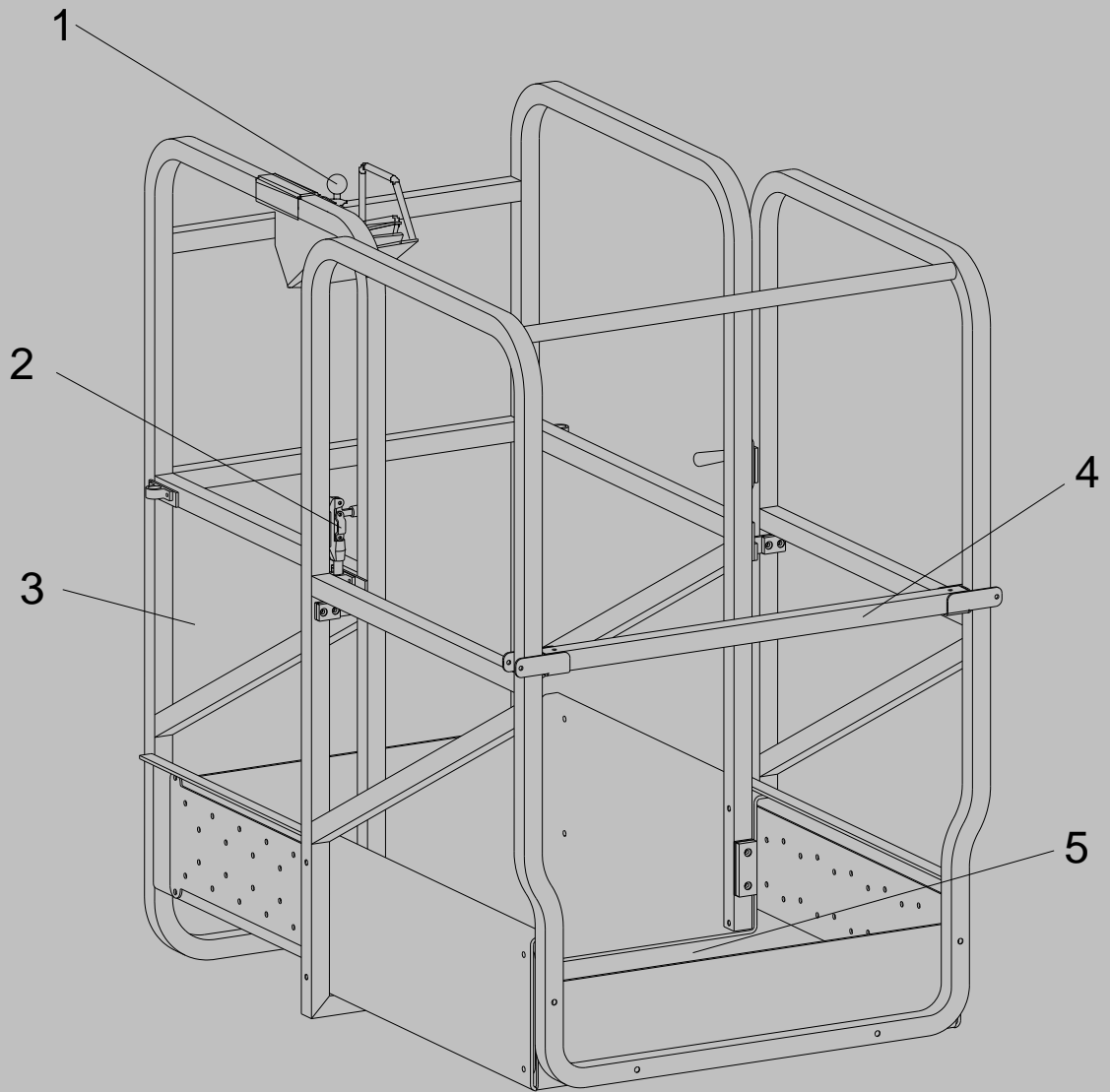

EXTENDIBLE PLATFORM (SLIDING BAR ENTRY)

Model	Max. Capacity
AMWP6-1000	125kg
AMWP7.5-1000	100kg
AMWP7.5-2000	175kg
AMWP9-2000	125kg

1. Platform Control Console	4. Sliding Bar Entry Gate
2. Extension Slide/Lock Handle	5. Sliding Extendible Section
3. Lanyard Attach Point (on mast)	

3.10 FALL PROTECTION – LANYARD ATTACHMENT

CAUTION

THE MANUFACTURER RECOMMENDS THE OPERATOR IN THE PLATFORM WEAR A FULL BODY HARNESS WITH A LANYARD ATTACHED TO AN AUTHORIZED LANYARD ANCHORAGE POINT.

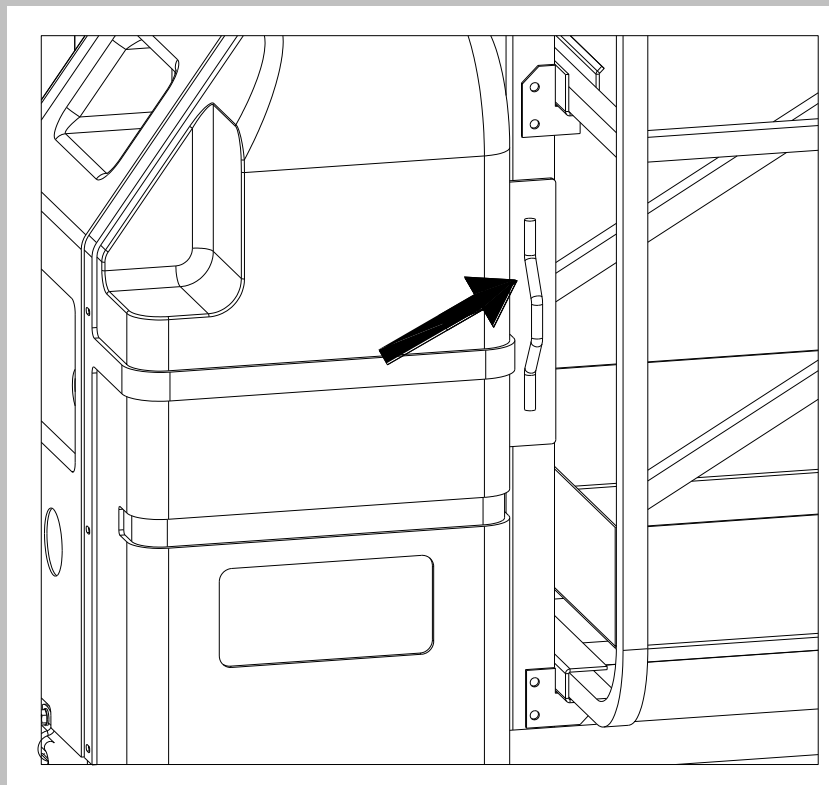
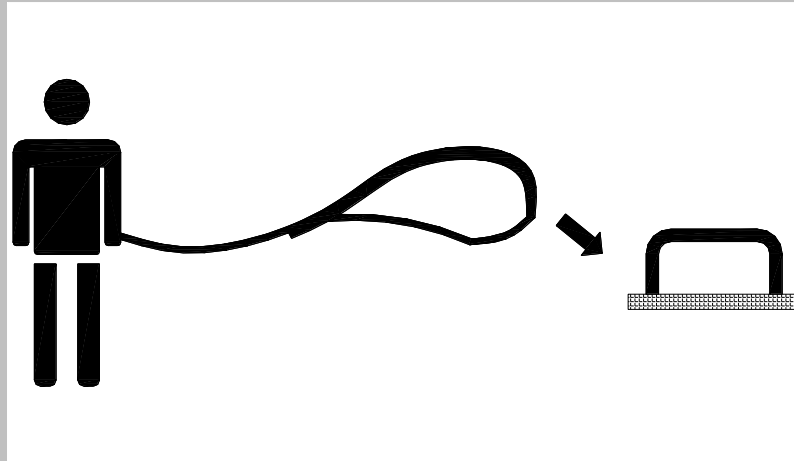

The main lanyard attach point for all AMWP machines is located on the lower right side of the mast platform header, just behind the operators platform.

CAUTION

AFTER ENTERING THE PLATFORM, BEFORE BEGINNING OPERATION ALWAYS CLOSE THE PLATFORM ENTRY GATE (S).

3.11 QUICK-CHANGE PLATFORM MOUNTING

AMWP Model Lifts are equipped with quick-change platform mount, which allow quick removal and installation of currently available quick-change platform.

NOTE: AMWP Models require the installation of the Quick-Change mount kit to use Quick-Chang Platforms.

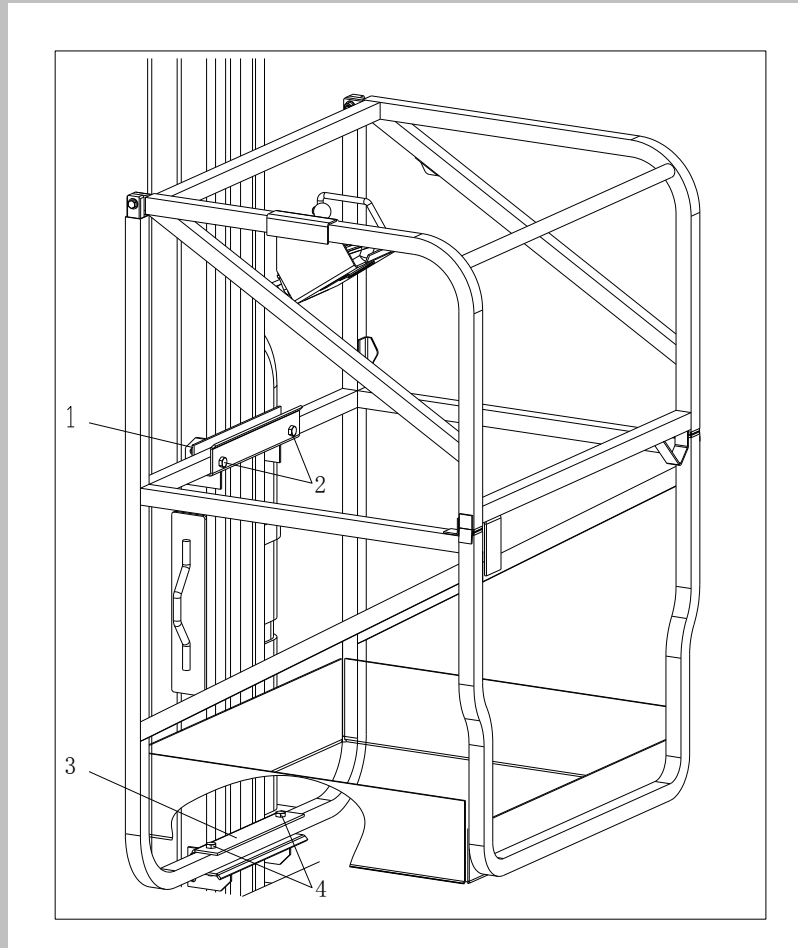

- | | |
|--------------------------|--------------------------|
| 1. Upper Platform Mount | 3. Lower Platform Mount |
| 2. Upper Mount Fasteners | 4. Lower Mount Fasteners |

Platform Removal

1. Remove the platform control console from the platform and lay aside.
2. Remove both upper and lower mount fasteners securing the platform support rails to the mast mounting channels.
3. Swing and lift the platform out of the mounts and lay aside.

Platform Installation

1. Set platform in upper and lower mounts.
2. Install mount fasteners in upper and lower mounts.
3. Attach platform control console to platform rail.

WARNING

ENSURE ALL FASTENERS ARE INSTALLED AND SECURE PRIOR TO OPERATION.

3.12 TRANSPORTING, LIFTING AND TIE DOWN PROCEDURES

General

All AMWP Series Model Personnel Lifts may be transported to a work site using the following methods:

- Driving the machine around on its base wheels if travel surface area permits.
- Loaded, IN AN UPRIGHT POSITION ONLY onto a heavy-duty vehicle with the payload capacity capable of supporting the full weight of the machine (Check machine gross weight in the Operating Spec Chart at the beginning of this Section).
- Moved with a forklift truck using the forklift pockets in the base frame.

Truck Transport

CAUTION

DO NOT TRANSPORT THE MACHINE IN A HORIZONTAL POSITION DUE TO LEAKAGE OF BATTERY ACID FROM THE BATTERIES OR HYDRAULIC FLUID FROM THE HYDRAULIC RESERVOIR.

The machine may be winched onto a tilted roll-back truck bed (see important note following), which has been rolled back to ground level. Disengage the brakes and always winch (pull) from the mast (rear) end of the machine.

IMPORTANT

DO NOT ATTEMPT TO DRIVE MACHINE ONTO, OFF OF, OR PUSH MACHINE ONTO A TILTED ROLL-BACK TRUCK BED.

THE AMWP MACHINES POWER MODULE COULD SUSTAIN SERIOUS DAMAGE WHEN THE UNIT IS PUSHED, OR TOWED AT SPEEDS GREATER THAN 2 MPH.

WHEN TOWING OR WINCHING, THE MACHINE'S BRAKES MUST BE DISENGAGED.

RE-ENGAGE THE BRAKES ONCE MACHINE IS IN PLACE WITH TRUCK BED LEVEL AND READY FOR TIE DOWN.

Machine Tie-Down

With machine in position to be tied down and brakes engaged, use the following guidelines for restraining the machine during transport.

IMPORTANT

USE OF EXCESSIVE FORCE WHEN SECURING MACHINE (DRIVE WHEEL LOAD), CAN CAUSE DAMAGE TO THE MACHINES DRIVE WHEEL COMPONENTS.

1. Secure machine with an adequate chain attached through the tie down loops located at the front and rear of machine. (See Figure 3-11.)
2. The chain should be securely tightened with a force of approximately 100 lb. applied two feet from the pivot handle.

NOTE: Lifting device must be capable of handling the gross weight of the machine, see the Operating Specifications table at the beginning of this Section.

Fork-Lift Truck Transport

All AMWP Model Lifts are equipped with wide forklift pockets running through the base frame. (See Figure 3-11.) This allows the machine to be either transported around a work area or lifted onto a higher level using a standard fork-lift truck.

NOTE: Fork-lift trucks must be capable of handling the gross weight of the machine, see the Operating Specifications table at the beginning of this Section.

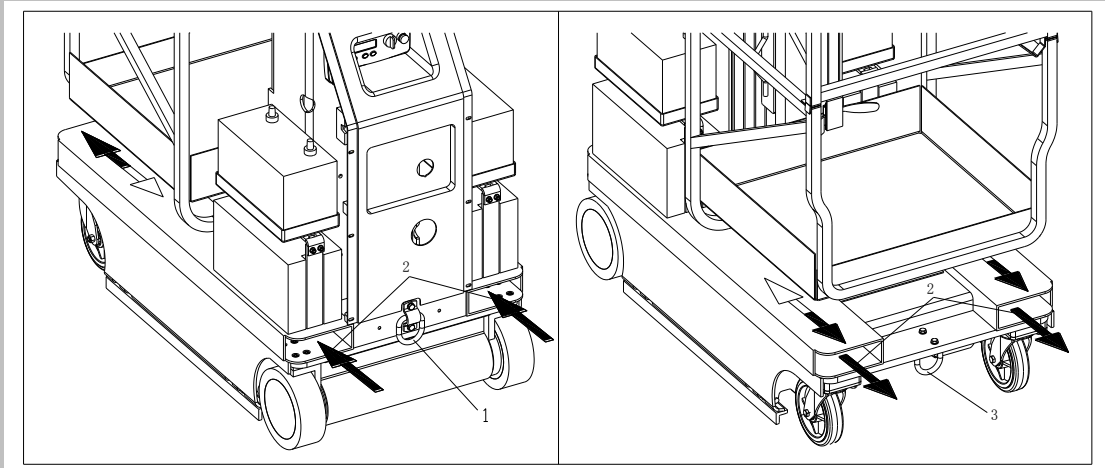

Figure 3-4. Forklift Truck Lifting Pockets and Machine Tie Down Bar Locations.

1. Rear Tie-Down Loop
2. Fork Lift Pockets
3. Front Tie-Down Loop

SECTION 4. EMERGENCY PROCEDURES

4.1 GENERAL INFORMATION

This section explains the steps to be taken in case of an emergency situation during operation.

4.2 EMERGENCY OPERATION

Operator Unable to Control Machine

IF THE PLATFORM OPERATOR IS PINNED, TRAPPED OR UNABLE TO OPERATE OR CONTROL THE MACHINE:

1. Other personnel should operate the machine from ground controls only as required.
2. Only qualified personnel in the platform may use the platform controls. DO NOT CONTINUE OPERATION IF CONTROLS DO NOT FUNCTION PROPERLY.
3. Cranes, forklift trucks or other equipment can be used to remove the platform occupant and stabilize motion of the machine.

Platform Caught Overhead

If the platform becomes jammed or snagged in overhead structures or equipment, rescue the platform occupant prior to freeing the machine.

4.3 INCIDENT NOTIFICATION

The manufacturer must be notified immediately of any incident involving an AMWP product. Even if no injury or property damage is evident, the factory should be contacted by telephone and provided with all necessary details.

Failure to notify the manufacturer of an incident involving a product within 48 hours of such an occurrence may void any warranty consideration on that particular machine.

IMPORTANT

FOLLOWING ANY ACCIDENT, THOROUGHLY INSPECT THE MACHINE AND TEST ALL FUNCTIONS FIRST FROM THE GROUND CONTROL STATION, THEN FROM THE PLATFORM CONTROL CONSOLE. DO NOT LIFT ABOVE 10 FT. (3M) UNTIL YOU ARE SURE THAT ALL DAMAGE HAS BEEN REPAIRED, IF REQUIRED, AND THAT ALL CONTROLS ARE OPERATING CORRECTLY.

SECTION 5. GENERAL SPECIFICATIONS AND OPERATOR MAINTENANCE

5.1 INTRODUCTION

This section of the manual provides additional necessary information to the operator for proper operation and maintenance of this machine.

The maintenance portion of this section is intended as information to assist the machine operator to perform daily maintenance tasks only, and does not replace the more thorough Preventive Maintenance and Inspection Schedule included in the Service and Maintenance Manual.

Other Publications Available Specific to this Machine:

Service and Maintenance Manual

Illustrated Parts Manual

5.2 GENERAL SPECIFICATIONS

Machine Specifications

SPECIFICATION	AMWP6-1000	AMWP7.5-1000	AMWP7.5-2000	AMWP9-2000
Gross Machine Weight (Platform Empty):	850kg	880kg	1100kg	1250kg
Machine Height (Platform Stowed):	198cm			
Maximum Ground Bearing Pressure: (per wheel)	360kg			
Maximum Operating Incline:	1.5°			
Maximum Travel Grade (Grade ability): (Platform STOWED ONLY)	15-20%			
Maximum Travel Grade (Side Slope): (Platform STOWED ONLY)	5°			
Maximum Drive Speeds (Operator Variable):	0.6-4 km/h			
Maximum Base – Overall: (Width × Length)	76cm × 136cm		100cm × 150cm	
Maximum Wind Speed:	0 km/h-Machine rated for indoor use only			
Maximum Horizontal Manual Side Force: (Platform fully extended with Maximum load)	100 N		200 N	
Maximum Hydraulic System Pressure: (Recommended initial setting)	12MPa			
Hydraulic Reservoir Capacity:	5L		5L	

Machine Dimension

Model	Max. platform height	Max. working height	Rated load	The number of persons allowed on platform	Platform size A×B	Stored dimension L×W×H
	mm	mm	kg	Person(s)	mm	mm
Amwp6-1000	6000	7700	150	1	695×780	1360×790×1980
Amwp7.5-1000	7500	9200	125	1	695×780	1360×790×1980
Amwp7.5-2000	7500	9200	200	1	695×1000	1500×1000×1980
Amwp9-2000	9000	10700	150	1	695×1000	1500×1000×1980

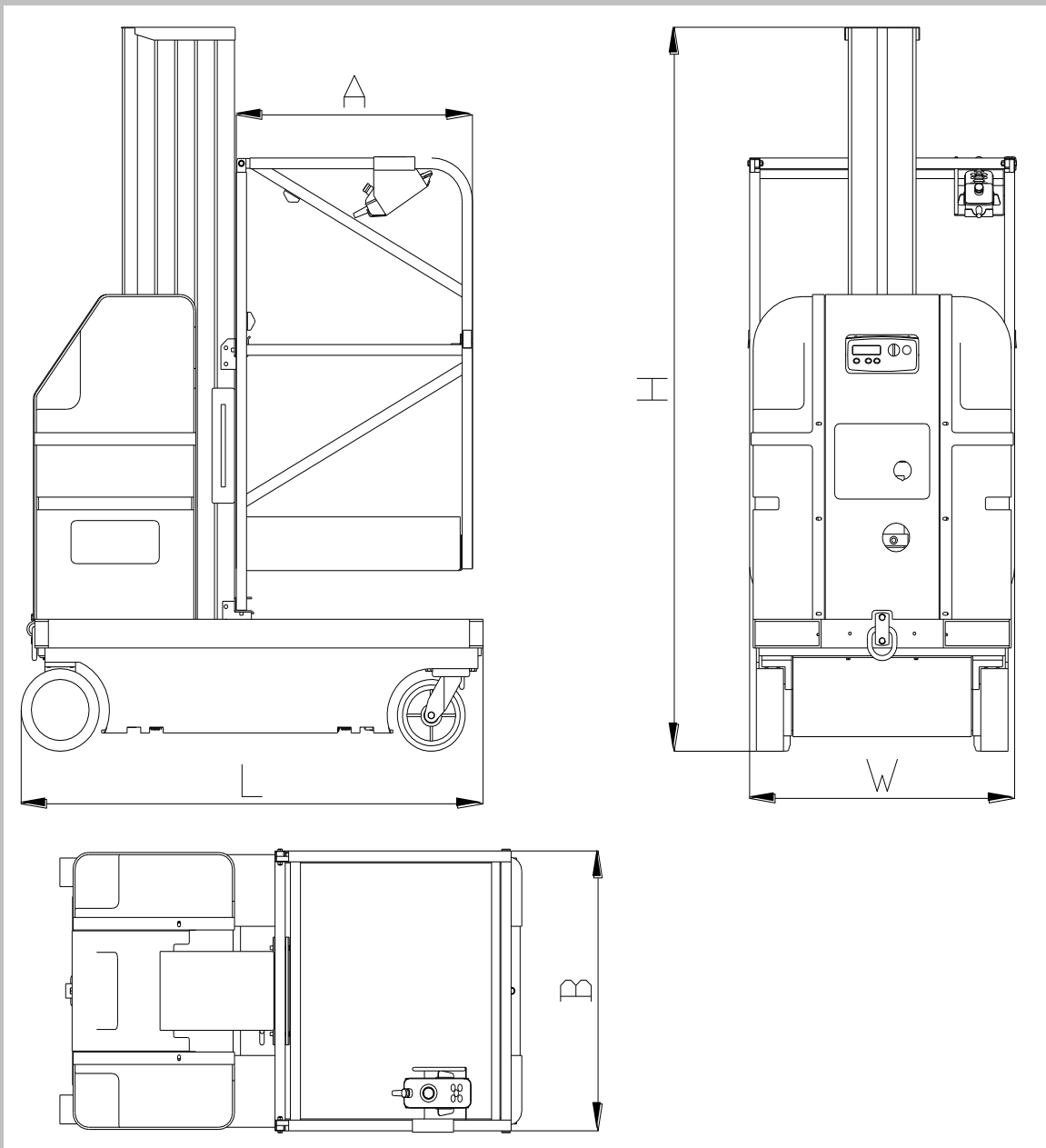

Machine Operating Area

Machine Type	Amwp6-1000	Amwp7.5-1000	Amwp7.5-2000	Amwp9-2000
R	1350	1350	1500	1500

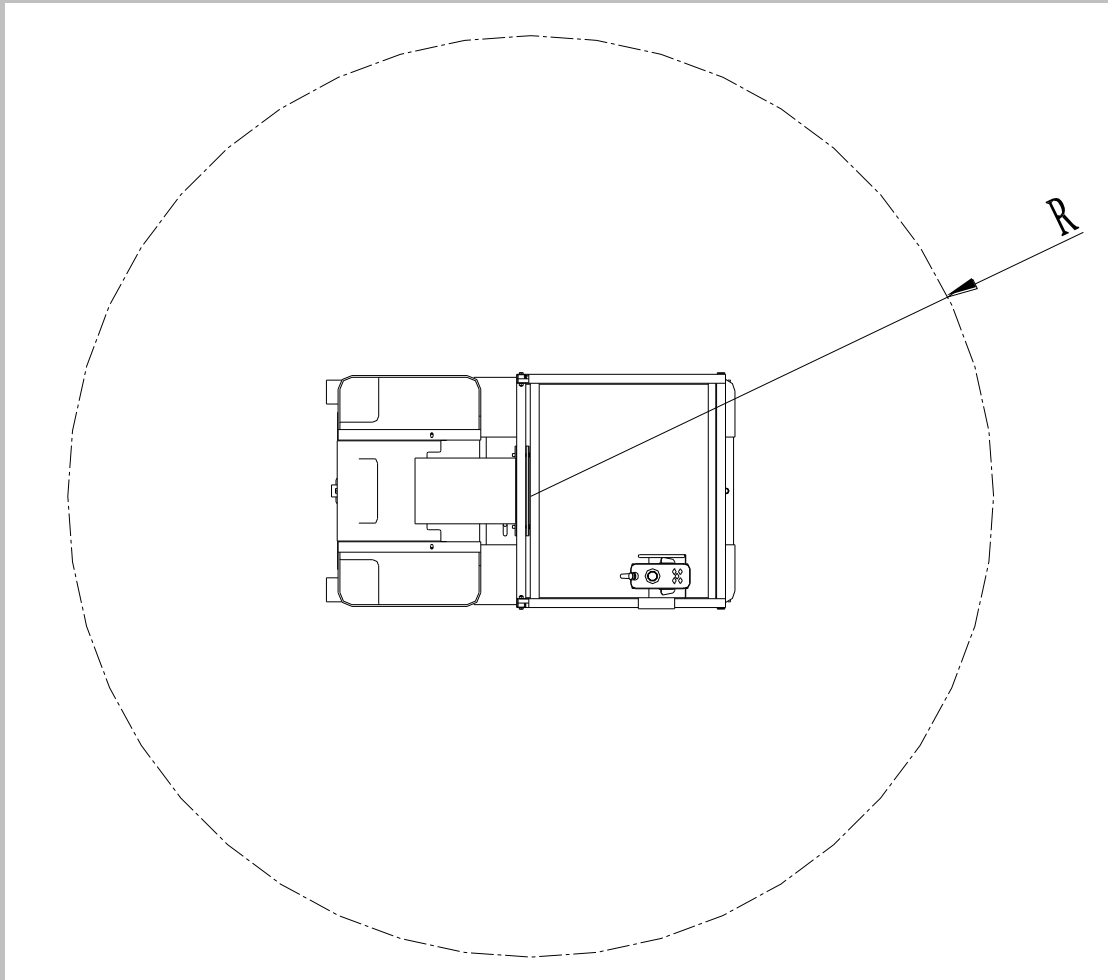

Electrical Specifications

SPECIFICATION	Amwp6-1000,Amwp7.5-1000,Amwp7.5-2000, Amwp9-2000,	
System Voltage:	24 Volts DC	
Battery Specifications:	Battery Type:	
	Voltage:	12 Volts DC
	Amp Hour (AH) Rating:	100 Amp Hr. @20Hr.
Battery Charger (DC Models)	Input:	120/240 Volts AC-50/60 Hz –Voltage Selectable
	Output:	24 volt, 20 Amp Output – with 2 Amp Finish

Hydraulic Diagram (for amwp6-1000 and amwp7.5-1000)

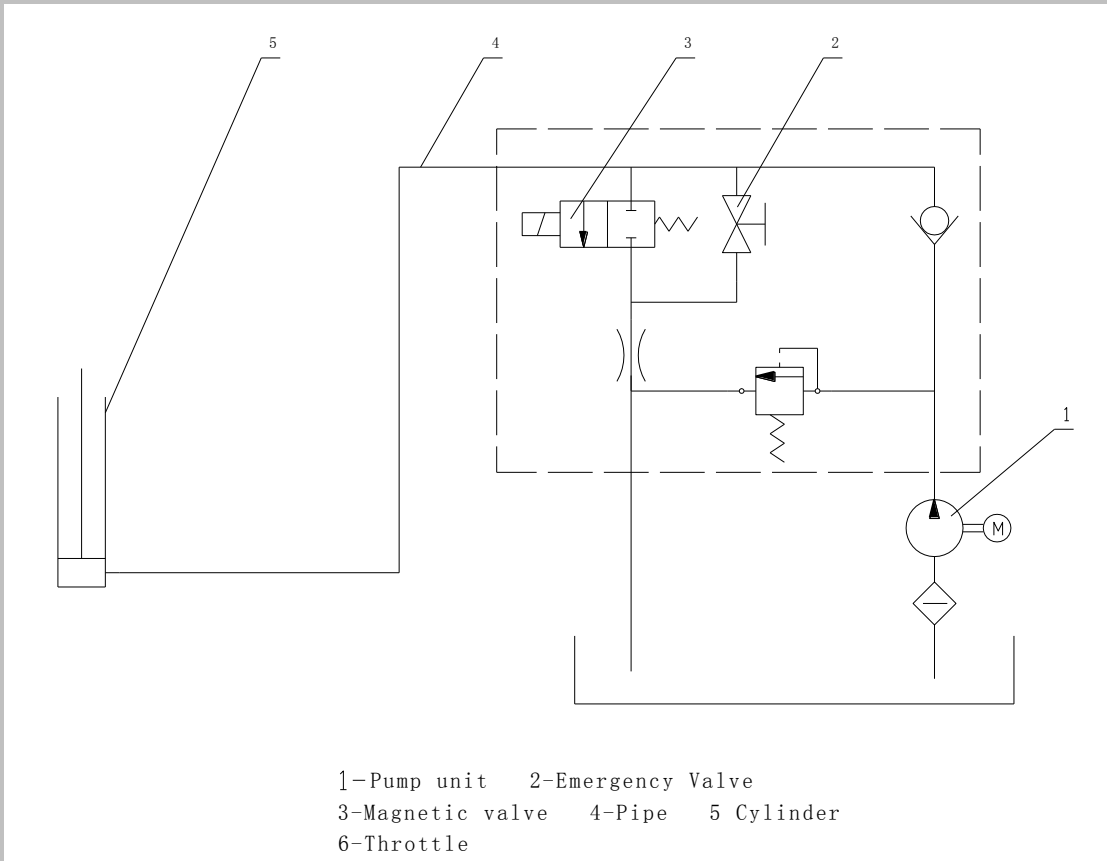

Hydraulic Diagram (for amwp7.5-2000 and amwp9-2000)

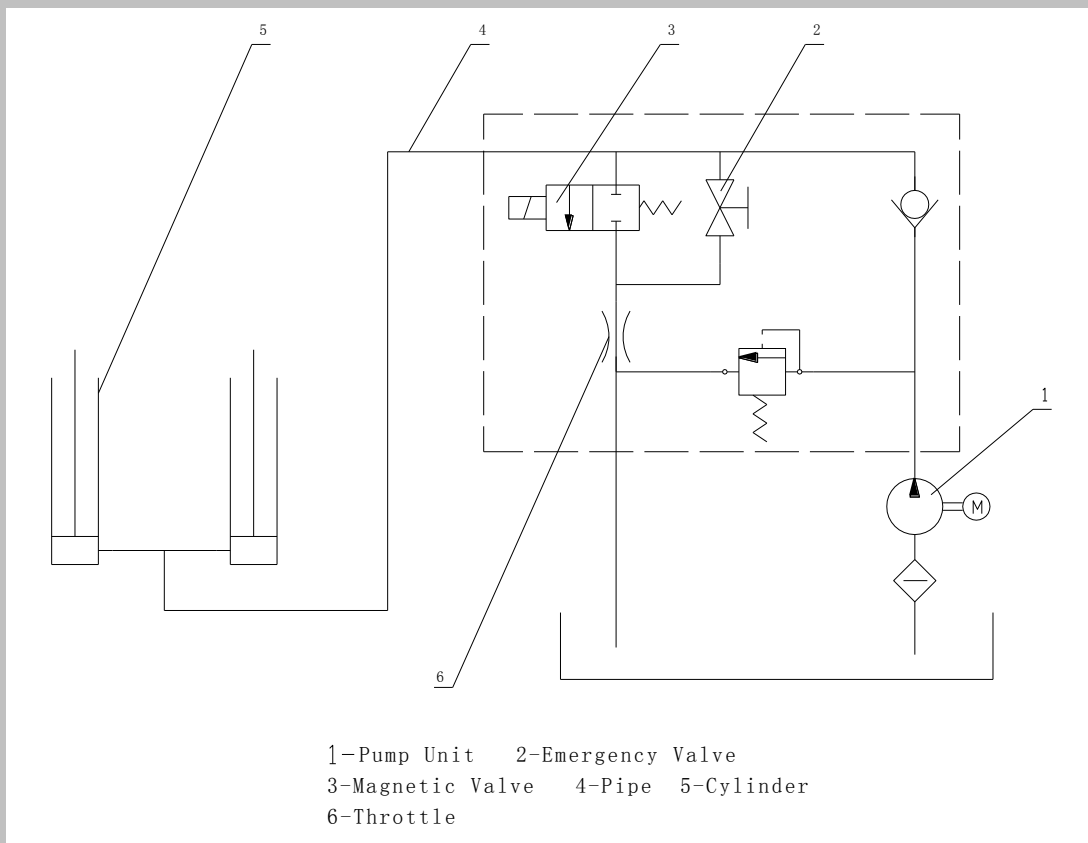

Table 5-1. – Lubrication Specifications

KEY	SPECIFICATIONS
MPG-	Multipurpose Grease having a minimum dripping point of 350° F. Excellent water resistance and adhesive qualities, and being of extreme pressure type. (Timken OK 40 pounds minimum.)
EPGL-	Extreme Pressure Gear Lube (oil) meeting API service classification GL-5 or MIL -Spec MIL -L-2105.
HO-	Hydraulic Oil. ISO-Vg grade 32, 46.
CL-	Chain Lube. Use a good quality chain lubricant

NOTE: Refer to Lubrication Chart, Table 5-2 for specific lubrication locations on machine

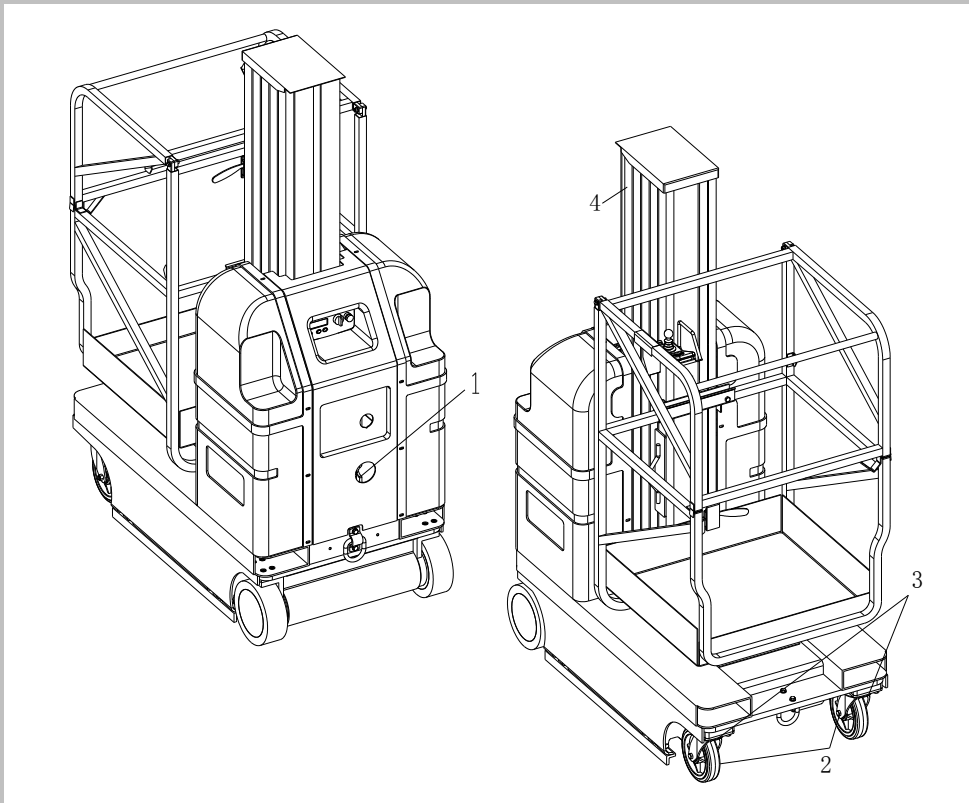

Table 5-2. Lubrication Intervals for Various Components

ITEM	COMPONENT	NO/TYPE ^(a) LUBE POINTS	LUBE/METHOD	INTERVAL ^(b)				COMMENTS
				3 MONTHS	6 MONTHS	1 YEARS	2 YEARS	
1	Hydraulic oil	Fill the Reservoir	HO-Check Hyd. Oil Level HO-Change Hyd. Oil			✓		Check fluid level every day. ^(c) Change hydraulic oil every 1 year.
2	Caster Axles	2-Grease Fittings	MPG-Pressure Gun	✓				
3	Swivel Raceways	2-Front Casters	MPG-Pressure Gun	✓				
4	Mast Chains	2-Per Mast Section	CL-Brush or Spray		✓			Inspect, lubricate if dry or rusting.
Key to Lubricants: MPG - Multipurpose Grease HO - Hydraulic Oil – ISO-Vg grade 32, 46. CL - Chain Lube. Use a good quality chain lubricant								
Notes: (a) Be certain to lubricate like items on each side of the machine. (b) Recommended lubricating intervals are based on normal use. If machine is subjected to severe operating conditions, such as a high number of cycles, location, corrosive/dirty environment, etc., user must adjust lubricating requirements accordingly. (c) Prior to checking hydraulic oil level, operate machine through one complete cycle of lift function (full up and down). Failure to do so will result in incorrect oil level reading on the hydraulic reservoir.								

BATTERY WARNING

Battery posts, terminals and related accessories contain lead and lead compounds, chemicals known to cause cancer and reproductive harm.

Batteries also contain other harmful chemicals.

WASH HANDS AFTER HANDLING!