

AUTO TOOLS

A-1

CAR OPENERS

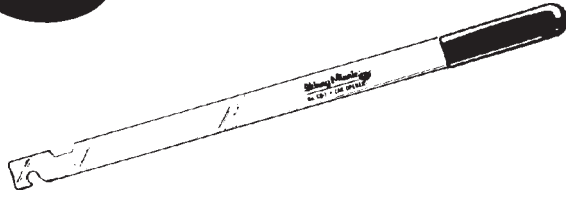

A1-CO1 Skinny Minnie

Still the most reliable and universal car opening tool available. While many newer cars require a more specific device, the Skinny Minnie is still the tool of choice for thousands of cars on the road today.

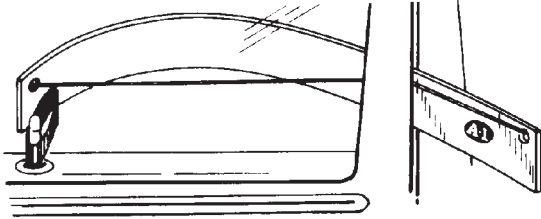

A1-CO2 Vulcan Button Grabber

Unique rubber loop GRABS and HOLDS buttons, without damage. Open up a whole new world with this simple but effective car opener. The rubber loop grabs and holds most buttons, even straight ones. Easily enters through door jam. Use string for alignment. Great for Mercedes, BMW, Volvo.

AUTO TOOLS



CAR OPENERS

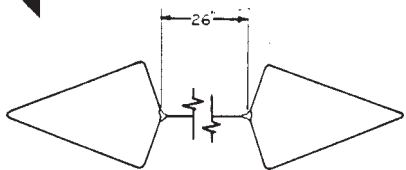

ES-AWT-100 Scrawny Lonnie

The famous tools that professionals use to open locked autos. The wire "snake" reaches in between door frame and glass to the button. No damage to window or weather stripping. Takes a little practice, but once you've got the technique, you'll never miss! (Even works on tapered "No-head" buttons!)



ES-SNIK-1 Slide-Nik

A new unique tool for the professional locksmith! The new SLIDE-NIK allows you to open late model GM doors with slide locks in a matter of seconds. What's more, with a minimum of practice, 1981 and '82 GM doors can also be opened! Comes complete with easy-to-follow instructions.

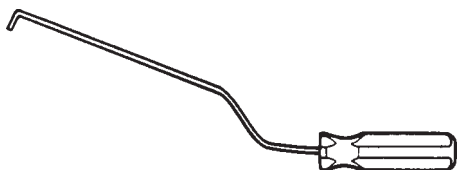

ES-TNIK-3 Trans-Nik

The new TRANS-NIK allows you to open doors on the 1983 and later model CAMARO, Z-28, BERLINETTA, FIREBIRD, AND TRANS-AM. All that is required is a minimum of practice and you will be saving that precious time that means extra profit! The new TRANS-NIK comes complete with easy-to-follow instructions.



ES-CPT-99 Chrysler Door Opener

The ES-CPT-99 Chrysler Door Opener allows you to open most Chrysler doors in a matter of seconds. All that is required is a minimum of practice and you will be saving that precious time that means extra profit! The new ES-CPT-99 comes complete with easy-to-follow instructions.

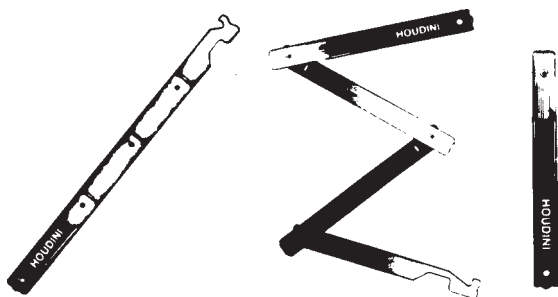

ES-HDNI-1 Houdini™

The HOUDINI™ folds up to fit snugly in your workshirt pocket or neatly in your toolbox. You'll find that the HOUDINI™ eliminates the frustrating problem of misplacing or losing your emergency car door opener!



ES-ASTRO-1 Chevrolet - Astro Van Opening Tool

The ES-ASTRO-1 opens the Astro Van in no time at all with a minimum of effort. The time saved translates into profit in your pocket! The ES-ASTRO-1 is furnished with complete easy-to-follow instructions.

ES-FAV-1 Ford Aerostar Van Opening Tool

The new Ford Aerostar Van Opening Tool is one tool that no locksmith should be without. The ES-FAV-1 quickly and easily opens the Aerostar Van with a minimum of practice, saving you time and putting extra profits into your pocket! Comes complete with easy-to-follow instructions.

AUTO TOOLS

HPC

CAR OPENERS

DELUXE OPENER SET



CO-4



*The only opener
for cars with
vented windows*

This 6 piece tool set is one of HPC's longest standing products. Although it remains virtually unchanged from its original design, the CO-4 has many applications on all models of autos and trucks with vent windows.

COLLAPSIBLE OPENER



CO-6

This tool is the only one (aside from the CO-4) that is currently in production that preceded the Slim Jim™. The CO-6 was retained in HPC's line because it has many current applications. Once the three segments are assembled, the tool totals 62" in length and can reach across the car to unlock the opposite door.

SLIM JIM™



The Original

CO-10

HPC's Slim Jim™ has been the entry tool by which all others have been judged since its introduction back in 1967. Although automobiles have changed considerably in recent years, the large number of applicable cars on the road allows the Slim Jim™ to remain a necessity for all auto lock specialist.

SUPER JIM™



CO-11

The Super Jim™ is a wider version of the Slim Jim™ and on some models may be faster.

SIR JAMES™



CO-18

The Sir James™ is a deluxe version of the Super Jim™. It has pre-scribed depth graduations on its face and has a built-in note pad for recording pick up points and exact opening procedures. Also included is a genuine leather handle.

PEG LEG JIM™



CO-20

The Peg Leg Jim™ is for models worth protected linkage. Some 1980's GM used cylinder covers, etc., on random model autos.

MERCEDES BENZ OPENER



CO-21

This tool open European car models with vacuum operated locks. Since these cars don't die easily, the CO-21 remains an essential tool today. Also, the handle is very useful for many linkage applications.

JIM DANDY™

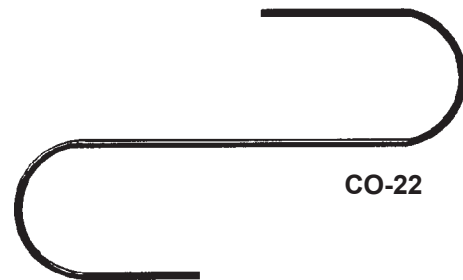

CO-22

The Jim Dandy™ is an extremely versatile under button opener. It is designed for GM models other than "X" and is also great on most Japanese cars and trucks.

AUTO TOOLS

HPC

CAR OPENERS

BIG JIM™



CO-24

The Big Jim™ is made especially for "X" type GM's, plus it will open almost every vehicle that the Slim Jim™ will.

JIMMY™



CO-26

The Jimmy™ opens most grip handle GM models (1970 to 1980) including the Chevrolet Corvette.

VERTICLE LINKAGE MASTER



CO-35

The Verticle Linkage Master was originally intended for use on Ford vans and small trucks, yet has proven to be highly effective on such vehicles as Toyota Cressida, Saab, Nissan Sentra and Maxima, Chevrolet Nova, Chrysler New Yorker and many other vehicles possessing vertical linkage.

CHRYSLER TOOL



CO-37

The Chrysler Tool is an "instant entry tool" specializing in late models. Entry is through drainhole.

VW VENT TOOL



CO-38

This vent tool is designed for many models of Volkswagens. Plus, it can open many domestic vans and pick-ups.

HORIZONTAL HOOK



CO-39

The Horizontal Hook offers a sure way to bind a horizontal rod and open dozens of late model General Motors vehicles.

MERCEDES SEL & SEC OPENER



CO-40

The CO-40 is designed for the infamous SEL and SEC model Mercedes. It is a modified version of the CO-21.

SINDWINDER™



CO-41

The Sidwinder™ opens Ford and Chrysler through the cylinder hole. It works through the drainhole in front of the lock to activate the lazy pawl.

AUTO TOOLS

HPC

CAR OPENERS

FORD THROUGH TOOL



CO-51

Although the Ford through tool was designed for the Ford Thunderbird, Mercury Cougar and Lincoln Mark VII, other autos with vertical button rods and grip handles can also be opened with it.

J FLEX™



CO-57

J Flex™ is a "Jack of all trades". By bending its strong flexible material you can make almost any configuration. Very useful for under button openings in tight spaces.

SUPER J™



CO-52

The Super J™ will allow you to open almost any auto with vertical linkage. The Super J™ was designed to give your Super Jim™ (CO-11) or Slim Jim™ (CO-10), an entirely new application. Either tool will enable the Super J™ to enter the door as a straight tool. Upon removal of CO-10 or CO-11, Super J™ returns to its original form. The bend also allows it to reach locations inside the door that would be otherwise isolated.

POCKET JIM™



CO-58

The modular design of the Pocket Jim™ gives you the flexibility to use any combination of segments to create a variety of tools. The Pocket Jim™ includes tips from the Slim Jim™ and the Peg Leg™. Not only can each tool grasp the vertical linkage straight down for fast opening, but their tips can be rotated a full 360 degrees to locate offset horizontal linkage.

ULTRA JIM™



CO-55

The Ultra Jim™ has the most popular of all car opener designs (Slim Jim™ style) in a flexible material. It allows you to custom bend and fully rotate the tool inside the door to bind or manipulate those hard to reach linkage areas.

CHEVY BERETTA



CO-59

The 1988 Chevrolet Beretta featured a revolutionary automotive locking system. This system proved to be extremely resistant to the car opening tools available at that time. The CO-59 was specifically developed to unlock the Beretta within a span of 30 seconds.

FLEXIBLE PEG LEG



CO-56

All the versatility of Peg Leg Jim™ combined with the flexibility to custom bend and rotate makes this an extremely useful tool for any bell crank, lazy pawl, vacuum boot or latch type opening.

AUTO TOOLS



CAR OPENERS

CADDY KILLER™

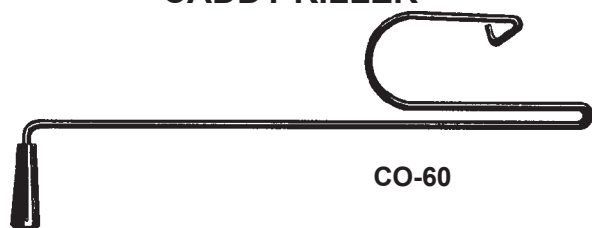

CO-60

The Caddy Killer™ is similar to the CO-59, but has increased height in the arc. It can open '86-'94 Cadillac Eldorado, '84-'94 Dodge Ram and '87-'94 Acura Legend and many others.

STRETCH KILLER™

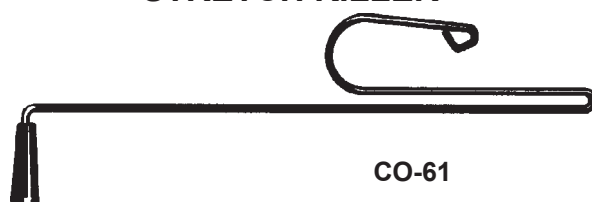

CO-61

The Stretch Killer™ is capable of opening the 1988 through the 1994 Buick Regal, Pontiac Grand Prix, Chevy Astro, etc.

SAFARI JOE™



CO-62

The Safari Joe™ is an extremely useful double sided tool designed to open the following models of GM small trucks: Chevy S10 pick-up, GMC S15 Jimmy (1982-1987), Chevy Astro, GMC Safari (1985-1990), Chevy Nova and Toyota Corolla. It has a slip resistant coating to help bind and move linkages.

GM JOE™



CO-64

The GM Joe™ is an extremely versatile tool which is designed to open almost every car designed by General Motors, in seconds. This includes the following models: Buick, Cadillac, Chevrolet, Oldsmobile, and Pontiac. Even after all the linkage has been disconnected, GM Joe™ can do the job. It goes straight to the latch mechanism (which varies only slightly between different General Motors models).

SUPER JOE™



CO-65

The Super Joe™ is designed to open a wide variety of vehicles having vertical button rods. Chrysler products offer the best applications, though countless other vehicles (especially Japanese imports) can be opened with Super Joe™.

ASTRO TOOL

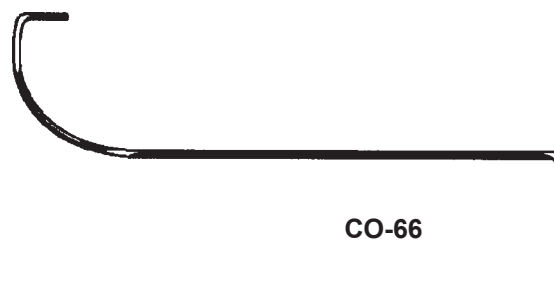

CO-66

The Astro Tool opens all 1984-1994 Chevy Astro Vans, plus most horizontal linkage GM vehicles. The CO-66 has proven to be the quickest, easiest way to manipulate the linkage in the Chevy Astro.

REVERSE OVER HOOK™

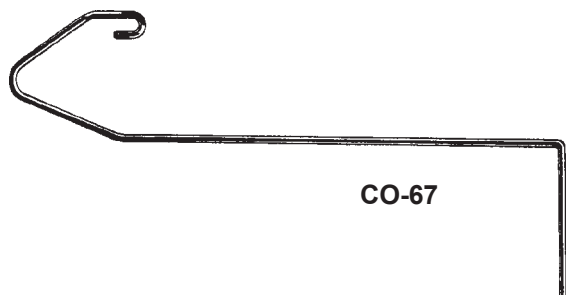

CO-67

The Reverse Over Hook™ is an extremely versatile tool designed to go around shielding and underneath the inner door panel to reach the horizontal linkage. It can also be very effective on vertical linkages. It can lift, lower, and rotate lazy pawls and some bell cranks. This tool is designed to open all General Motors, Ford Mercury, Nissan, Chrysler/Plymouth, Honda, Mitsubishi, Jeep and many more.

AUTO TOOLS

HPC

CAR OPENERS

OVER HOOK™

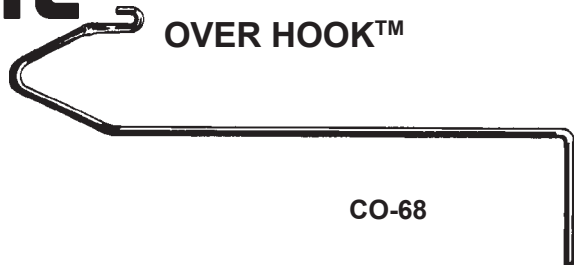

CO-68

The Over Hook™ is designed to hook onto horizontal control rods inside the car door, including some that might be located behind the window or other obstruction. The tool can go down, then back up, behind the window to hook onto a control rod. Although the Over Hook™ is primarily for use on GM cars, it can be used on other vehicles, including several foreign vehicles.

SUPER KILLER™

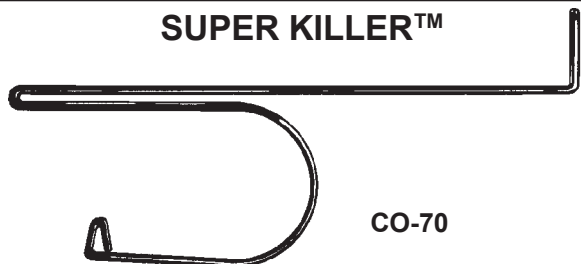

CO-70

The Super Killer™ with its extra length and great strength can be used to open a wide variety of vehicles. By inserting the tool at an angle, it can get under the deepest windows. The strength of the Super Killer™ is such that it can be used to push, pull or lift lock indicators, even those operated by power door locks. The CO-70 can open many new vehicles, especially GM's.

STRETCH DOUBLE "L"

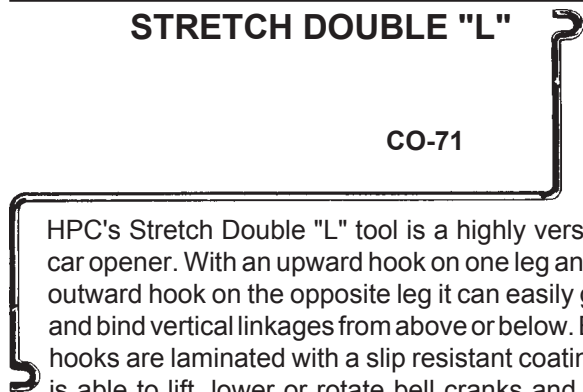

CO-71

HPC's Stretch Double "L" tool is a highly versatile car opener. With an upward hook on one leg and an outward hook on the opposite leg it can easily grab and bind vertical linkages from above or below. Both hooks are laminated with a slip resistant coating. It is able to lift, lower or rotate bell cranks and lazy pawls. It is also able to reach around many shields. The Stretch Double "L" tool works best on doors with thick door panels. It can be used on all General Motors, Ford Lincoln Mercury, Mitsubishi, Mazda, Honda, Hyundai, Chrysler/Plymouth, Toyota, Nissan, BMW, Jaguar and many more.

SHORT DOUBLE "L"

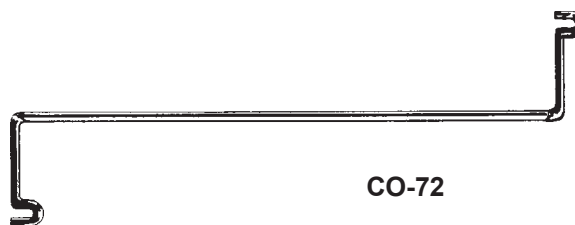

CO-72

HPC's Short Double "L" tool is a highly versatile car opener. With an upward hook on one leg and an outward hook on the opposite leg it can easily grab and bind vertical linkages from above or below. Both hooks are laminated with a slip resistant coating. It is able to lift, lower or rotate bell cranks and lazy pawls. It is also able to reach around many shields. The Short Double "L" tool works best on doors with narrow panels. It can be used on all General Motors, Ford Lincoln Mercury, Mitsubishi, Mazda, Honda, Hyundai, Chrysler/Plymouth, Toyota, Nissan, BMW, Jaguar and many more.

LASSO™



CO-73

The Lasso™ tool is for vehicle entry when the lock button is visible. It is made of high quality "poly-flexo" material with a durable string. The tool allows you to wrap the string around the lock button and lift up to unlock the door.

TRIP TOOL™

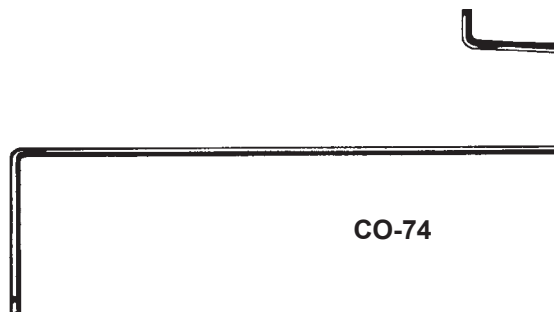

CO-74

The Trip Tool is designed to rotate the bell crank within an inner door panel. It can also be used to lower, raise or rotate bell cranks, lazy pawls or exposed linkages. The Trip Tool easily opens Toyota Previa and Camry. Plus, it can be used on Nissan, Mercury and Chrysler.

AUTO TOOLS



CAR OPENERS

HORIZONTAL CLUTCH™

CO-75

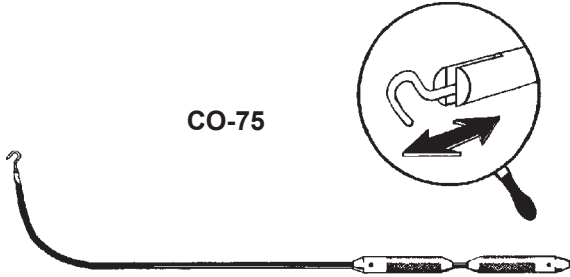

The Horizontal Clutch™ is unlike any others on the market. When the handle of the tool is pulled apart, the hook at the end of the tool is pulled inward, causing the tool to grip or bind the linkage rod. This new type of car entry tool will help to simplify the "in-the-door" method of vehicle entry. The Horizontal Clutch™ is for vehicles with horizontal linkage. (Patent Pending)

VERTICAL CLUTCH™

CO-76

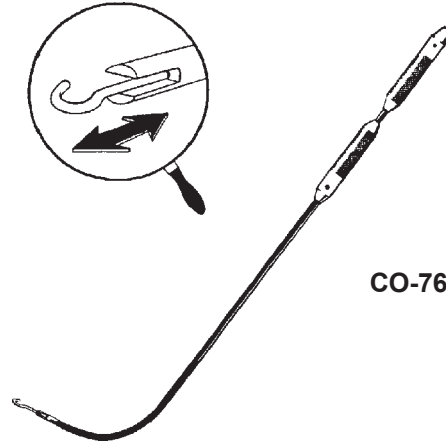

The Vertical Clutch™ is unlike any others on the market. When the handle of the tool is pulled apart, the hook at the end of the tool is pulled inward, causing the tool to grip or bind the linkage rod. This new type of car entry tool will help to simplify the "in-the-door" method of vehicle entry. The Vertical Clutch™ is for vehicles with vertical linkage. (Patent Pending)

AUTO TOOLS

HPC CAR OPENER KITS

HPC's new **Modular Killer Kits** allow you to build your car opener kit from a Starter Kit to an Ultimate Kit or anywhere in between. There are five kits available (Starter Killer Kit, Pro Killer Kit, Deluxe Killer Kit, Classic Killer Kit, and Ultimate Killer Kit), each one adds several tools that are not included in the previous kit.

A STARTER KILLER KIT™



AKK-55

The Starter Killer Kit™ includes the Super Jim™ (CO-11) for vertical rods, Jim Dandy™ (CO-22) for under button, Horizontal Hook (CO-39) for horizontal linkages, the Stretch Killer™ (CO-61) for under and over style openings, and 3/8" auto wedges (AW-38). All these tools complete in a clear view plastic case.

B PRO KILLER KIT™

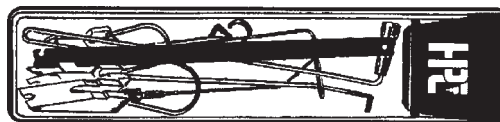

AKK-66

The Pro Killer Kit™ includes all the same tools as the Starter Kit, plus the Safari Joe™ (CO-62) for horizontal offset linkage, the Collapsible Opener (CO-6) for through the car, Mercedes Benz Opener (CO-21) for vacuum locks, Flex-A-Light™ (FAL-15), and 3/4" auto wedges (AW-34). The Pro Killer Kit comes complete in a clear-view plastic case.

C DELUXE KILLER KIT™

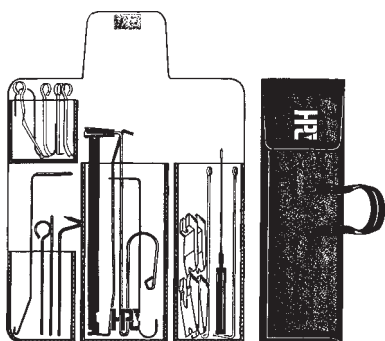

AKK-77

The Deluxe Killer Kit™ includes all the same tools as the Pro Killer Kit, plus the Deluxe Car Opener Set (CO-4) for vented windows, the VW Vent Tool (CO-38), the Chrysler Tool (CO-37), the Jimmy™ (CO-26), the Ford Through Tool (CO-51), and a three fold clear-view large plastic case.

D CLASSIC KILLER KIT™

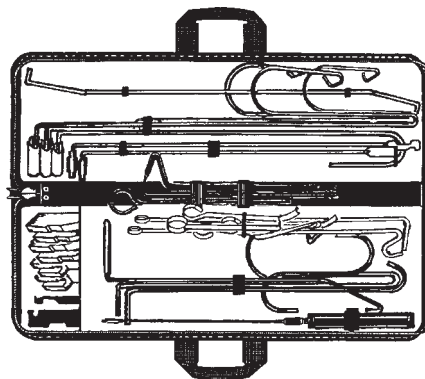

AKK-88

The Classic Killer Kit™ includes all the same tools as the Deluxe Killer Kit, plus all the HPC classics including the Ultra Jim™ (CO-55), the Flexible Peg Leg™ (CO-56), the J Flex™ (CO-57), the original Slim Jim™ (CO-10), the Super Killer™ (CO-70), the Caddy Killer™ (CO-60), and the Beretta Opener (CO-59). The Classic Killer Kit comes complete in a deluxe highly durable custom made carrying case.

E ULTIMATE KILLER KIT™

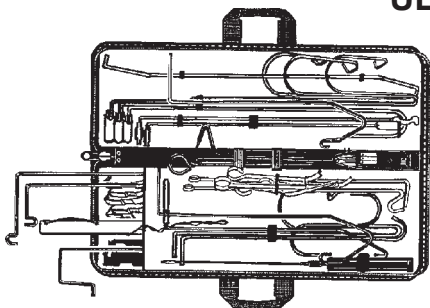

AKK-99

The Ultimate Killer Kit includes all the same tools as the Classic Killer Kit, plus the Over Hook™ (CO-68), the Reverse Over Hook™ (CO-67), the Stretch Double "L" (CO-71), the Short Double "L" (CO-72), the Lasso™ (CO-73), the Trip Tool (CO-74), and the Novice Pick Set (PIP-13). The Ultimate Killer Kit comes complete in a deluxe highly durable custom-made carrying case.

AUTO TOOLS



ACCESSORY PACKS FOR MODULAR KILLER KITS

(FOR UPGRADING KITS ON PREVIOUS PAGE)

The accessory packs listed at the right will upgrade the Modular Killer Kits shown on previous page to the next kit up. For example: if you have a AKK-55 Starter kit and you order a AP-1 accessory pack you will now have a AKK-66 Pro Killer Kit. Each pack contains the tools that are needed to upgrade to the next kit.

<u>No.</u>	<u>Description</u>
AP-1	Turns AKK-55 into AKK-66
AP-2	Turns AKK-66 into AKK-77
AP-3	Turns AKK-77 into AKK-88
AP-4	Turns AKK-88 into AKK-99

UNIVERSAL KILLER KIT™



The Universal Killer Kits™ come complete with a black plastic carrying case featuring a clear-view front and fully illustrated instructions and the following tools: AW-38, CO-10, CO-11, CO-22, CO-21, CO-39, CO-40, CO-56, CO-60. The AKK-E10 also comes with the FAL-15 light.

AKK-E10 (Pictured)

AKK-E9 (Same as AKK-E10 excluding FAL-15)

MISCELLANEOUS AUTO TOOLS

A-1



A1-GP1 Plug Puller for G.M.

Pull most G.M. trunk & deck plugs in seconds. Since the G-Pull never touches the auto body, there is no fear of scratching the paint or bending the body. Can also be used for some foreign autos and removable core padlocks, desk locks, etc.



A1-6 G.M. Lock Decoder

Works when others fail. This quality tool makes everyone a professional. Decode all years of G.M. sidebar without complete disassembly.

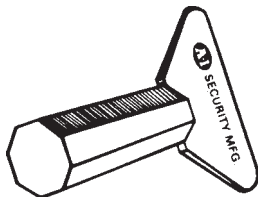

A1-8 Bezel Nut Wrench

Removes bezels found in G.M. glove compartment locks.

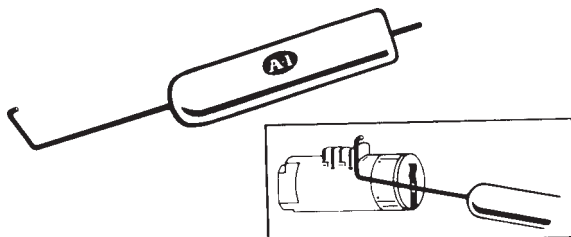

A1-5 G.M. Plug Remover/Poke Tool

A combination glove compartment plug remover and poke tool for ignition locks. To remove glove compartment plug, insert hook between the retainer and the No. 1 wafer. Hook over retainer slide and pull down and out. Works in locked or unlocked position.

AUTO TOOLS

A-1

MISCELLANEOUS AUTO TOOLS

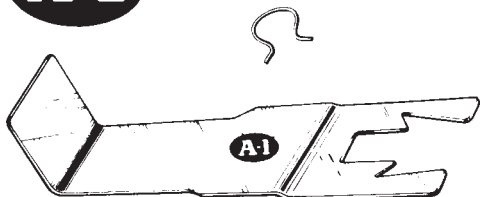

A1-DH2 Door Handle Clip Tool

Removes hard to reach clips from door handle and window cranks from G.M., Ford, and AMC.



A1-10 Retainer Clip Tool (10" version)

A1-10L Retainer Clip Tool (14" version)

Automotive retaining clips can be located in very difficult places. With this tool, you can remove and install them in a jiffy.

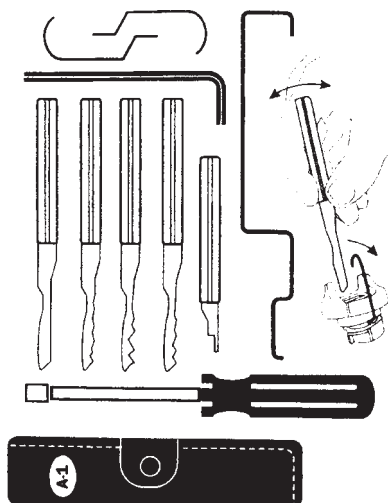

A1-PS2 For Servicing G.M. 10-Cut

Unlike others, no drilling is required. Developed by Carl Stramer, this set of tools will allow you to pick & decode G.M. 10-cut ignitions in minutes. Simply insert the special tension tool to apply sidebar pressure then pick the lock with your choice of 4 specially designed rocker picks. Once the lock is picked, use the cylinder release tool to release the ignition from the column. After removal, the plug can be decoded quickly and effortlessly using the depth gauge.

- Includes all tools required:
 - Tension tools, 4 rocker picks with leather case
 - Depth gauge, cylinder release tool, service manual.
- Lower shroud removal required on trucks only (tools incl.)

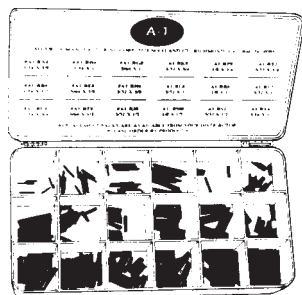

A1-R10 Foreign Automotive Roll Pin Kit

Over 300 roll pins, great for foreign ignition work. 18 Different sizes of roll pins specifically selected to service Japanese Automotive ignitions. Each part is clearly identified. Replacement vials are available by special order.

AUTO TOOLS



ALL-LOCK

SPECIALIZED AUTO TOOLS

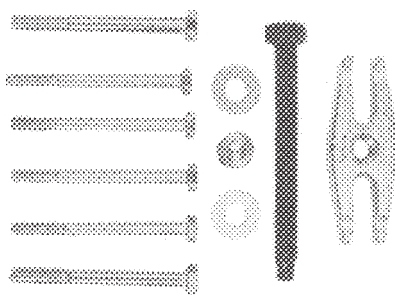

AL-9902

Steering Wheel Puller

Used for virtually all ignition lock replacements.

AL-9903

Lock Plate Tool For Saginaw Style Columns

AMC, GM and Chrysler products all require this tool to replace the ignition lock.

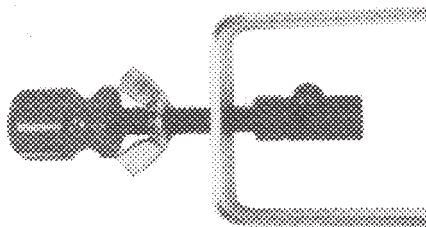

AL-9904

Removes trim panels without damage. Pops nylon and metal fasteners loose quickly and easily. A must for door lock work!

AL-9905

Makes removing/installing snap ring style door handles on AMC, GM and Chrysler cars a breeze.

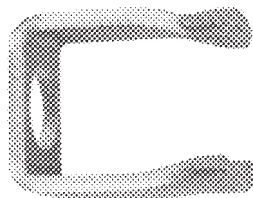
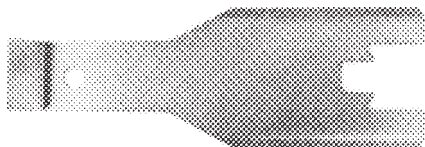

AL-9907

Lock Plate Tool

A must to service the ignition lock on the non-tilt Beretta/Corsica square column.

AL-9908

Tilt Telescope Adapter

Used with AL-9903 to service telescoping columns on AMC, GM, Chrysler.

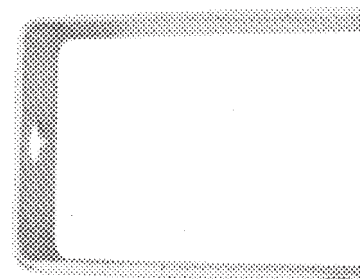

AUTO TOOLS



V.A.T.S. DECODER

**DECODES BOTH STYLE VATS KEYS—
SINGLE OR DOUBLE SIDE**



AL-A7000 V.A.T.S. DECODER

Vehicle Anti-Theft System—The All-Lock AL-A7000 V.A.T.S. Decoder makes diagnosing system failures, servicing the column and duplicating the correct key a snap.

The All-Lock V.A.T.S. Decoder is a sophisticated diagnostic tool, yet it's easy to use. Powered by a 9-volt battery (not included), the Decoder is totally portable. The long wire leads make it easy to use in cramped auto interiors. The All-Lock Decoder is housed in a compact steel case for years of service. Complete instructions on the inside of the lid are easy to use "on the job"

The Decoder performs 4 basic functions:

- Identifies correct V.A.T.S. key blank from customer's original.
- Decodes correct V.A.T.S. blank from the vehicle (if original key is lost).
- Diagnoses steering column connection problems.
- Diagnoses V.A.T.S. computer problems.

AL-A7001 V.A.T.S. ADAPTER

The AL-A7001 Adapter is required in order to connect the AL-A7000 V.A.T.S. Decoder to 1990 Cadillac models, 1991 Olds 98, Olds Touring Sedan and Buick Electra models.

The AL-A7001 is an absolute necessity for locksmiths who have purchased the All-Lock AL-A7000 V.A.T.S. Decoder. The Adapter further enhances the locksmiths' opportunities to work on vehicles with V.A.T.S. systems.

AL-A7002 KEY ADAPTER HARNESS ASSEMBLY

Use with All-Lock AL-A7000 V.A.T.S. Decoder for fast and easy hook-up without disassembling the dash board or the under dash connections. Five disposable plastic keys and a plug-in adapter harness are included. Complete instructions are provided.

AL-A7004 KEY ADAPTER

Set of five replacement key blanks for AL-A7002 above.

AL-A7005 DOUBLE SIDE V.A.T.S. KEY ADAPTER

Double side plastic key - When used with AL-A7003 Harness virtually eliminates under the dash work.

AL-LT7006 V.A.T.S. DECODER DOUBLE SIDE KEY ADAPTER

Retrofit all single side All-Lock AL-A7000 Vats Decoders and other brands to accept double side keys. Requires phillips screwdriver and less than 10 minutes to retrofit.

AL-LT7007 V.A.T.S KEY ADAPTER/HARNESS ASSEMBLY

Replaces P/N AL-A7002 - AL-LT7007 package contains (3) AL-A7004 Single Plastic keys; (3) AL-A7005 Double Plastic keys; and (1) AL-A7003 Harness Assembly.

AUTO TOOLS



MISCELLANEOUS AUTO TOOLS



KD-K-2 Jaws II-L Clip Removal Tool

SPECIAL FEATURE — Ball bearing holds clip in tool until YOU want it removed.
Design allows the Jaw II-L to bump up against the lock to help remove clips that are hard to take off.



KD-K-3 Straight Shot Clip Removal Tool

"The ultimate Corvette tool." Use where you have a "straight shot" at the clip. Approximately 18". **SPECIAL FEATURE** ball bearing holds clip in tool until YOU want it removed.

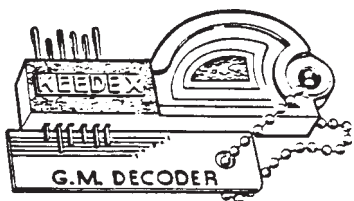

KD-K-4 G.M. Decoder

Decodes all tumblers in one step without complete disassembly of the lock. Pick sidebar down. Press the KD-K-4 firmly into the 6 chambers of the lock. Read cuts with gauge provided.

- Made of Lexan
- Guaranteed for life
- Stainless steel fingers
- Durable aluminum card
- Instruction and case included

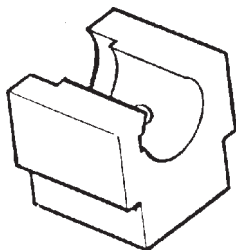

KD-K-7 G.M. Lock Block

The G.M. Lock Block is ideal for working on all General Motors locks. AMC and Chrysler side bar ignitions. It uses ball bearing action to hold lock firmly. This tool, with your vise, can be used for staking, recoding and repairing side bar locks. Special broach cut out allows checking of your work before installation in housing. A practical tool for service truck or shop use.

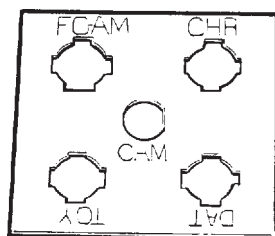

KD-K-8 Impressioning Plate

Specialized plate which holds locks as if they were still in the vehicle. The Impressioning Plate works with your vise to hold Chrysler, Ford, American Motors, Toyota, Datsun, and all standard cam locks. Made of stainless steel, it will hold all of the above locks firmly without crushing the outside casing. A must for every shop.

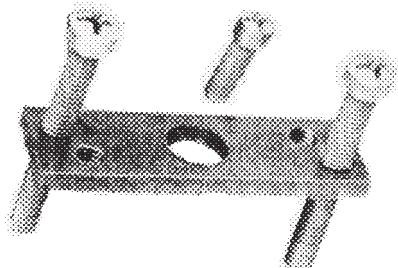

KD-K-10 G.M. Compressor

This pocket size tool compresses the lock plate spring on AMC, Chrysler tilt, G.M. tilt, telescopic, metric and standard steering columns. The tool is designed to use the same philips screwdriver needed to tear down the column. Great for night calls. A must for service trucks and shop.

AUTO TOOLS

MISCELLANEOUS AUTO TOOLS



CAR OPENING AUTHORITY™



LRB-230 (COA-22)

The Car Opening Authority™ is a user-friendly reference manual that includes every known type of professional vehicle entry. This manual is fully-illustrated and easily updateable. It comes in an attractive, durable binder with a clip on light to use for those all too common nighttime lockouts.

The manual is laid-out by opening style, this means that once you learn how to perform each of the opening styles, you can then open any car on the road! Each section includes all the types of specific opening styles, including a comprehensive listing of all the vehicles which can be opened with each method. Plus, it includes little tips which will make any vehicle a breeze to open.

The main index, with its simple spreadsheet format, makes looking up a specific vehicle by make, model or year extremely easy. The tool index also gives a pictorial listing of each type of tool used in the manual for a quick reference. The Car Opening Authority™ is backed by HPC's technical department, which truly makes this reference manual the AUTHORITY on car opening that you have been looking

for!



FLEX-A-LIGHT™

A New Concept in Probe Lights

More flexible than bending lights, yet rigid enough to keep straight.

FAL-10

10" Light
Power Handle

FAL-15X

Kit
15" Light
Power Handle
36" Extension

FAL-25X

Kit
10" Light
Power Handle
36" Extension

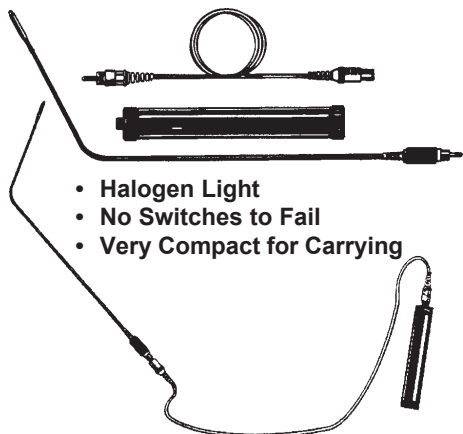

- Halogen Light
- No Switches to Fail
- Very Compact for Carrying

FAL-R10

Replacement 10" light extension (Special Order Only)

FAL-R15

Replacement 15" light extension (Special Order Only)

ULTIMATE AUTO WEDGES

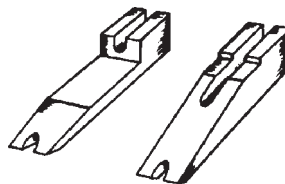

- AW-34** 3/4" maximum thickness
AW-38 3/8" maximum thickness

The ultimate auto wedges are designed for smooth safe insertion without risk of dropping into the door cavity. The edge of the wedges taper, to avoid it popping back out of the door. The special "illumination hole" allows nearly any flex light to pass through and focus directly on the desired location, without being held in your hand. Available in two popular sizes, 3/4" and 3/8" maximum thickness.

FLEXIBLE PROBE LIGHT

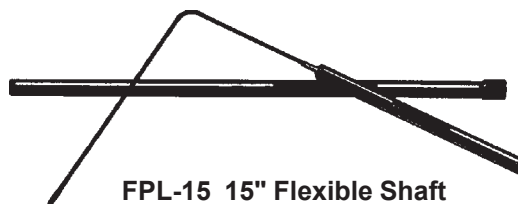

FPL-15 15" Flexible Shaft

This light is an economical, high intensity diagnostic tool designed for the locksmith professional. The shaft may be bent so that any angle will easily enter a 1/4" hole.

AUTO TOOLS

HPC

STEERING COLUMN LOCK PLATE COMPRESSION KIT

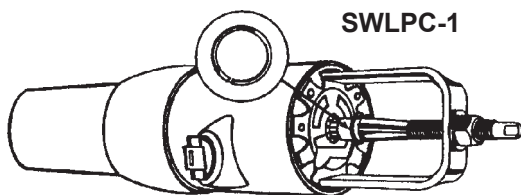

Complete Kit, includes both Standard & Metric Threaded shafts and set screws for telescoping columns.

This kit includes this metric internally threaded shaft and set screws that are required for 1978 to present General Motors. It also comes with a handy 9" x 12" vinyl pouch to carry this tool set plus many of your other automotive service devices.

Once the steering wheel is removed, simply screw the center post's threading onto the steering shaft and place the yoke over it. Turning inward on the center post nut compresses the plate. This leaves both hands free to pry the wire snap-ring out of the shaft's groove. Re-installation of the ring after servicing is accomplished by just sliding the ring down the tapered shank of the center post screw and back into the groove.

SWLPC-1B Metric Shaft Only (special order)



Lock Plate Compressor for Conventional
Steering Columns

LOCK PLATE COMPRESSOR



For Tilt and Telescopic Steering Columns. A specially designed lockplate compressor for tilt and telescopic columns used on General Motors. Assures an easier access to ignition lock retainer after steering wheel is removed.

CLIP REMOVAL TOOL

AST-3



Clip removal tool for door handle and window cranks. Used on General Motors, Ford and AMC automobiles. Easily removes the hard to reach retaining clips without damage.

CLIP REMOVAL TOOL FOR DOOR TRIM PADS

AST-4



Gaining access to the automobile door lock cylinder requires removal of the door trim pads as well as the regulator cranks.

Removing the trim pads without tearing out the nylon retainer clips has always been difficult.

The tapered end of this heavy duty lever type tool enters between the door and trim pad and persuades the pad off. This greatly reduces the possibility of tearing or damaging the pad and clips.

AUTO DOOR PANEL CLIP REMOVAL TOOL

AST-5



The offset design combined with a longer handle allows you to reach clips toward the center of the panel. A must for the locksmith specializing in automotive service. Saves time and work on both foreign and domestic models.

AUTO TOOLS

HPC

PLUG REMOVAL TOOLS

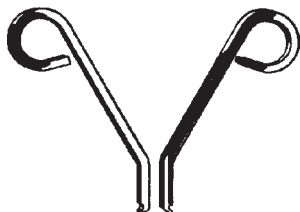

FPR-2

For removing plugs from many newer Ford and GM as well as Audi, Saab, and VW glove boxes. This Set of two tools allows swift removal of the lock plug from many newer Ford and GM glove compartments. It spreads the plastic retaining arms without breakage and pushes plug out safely. A necessary operation when obtaining correct code information.

RETAINER STAKING FIXTURE FOR GENERAL MOTORS AUTO LOCKS

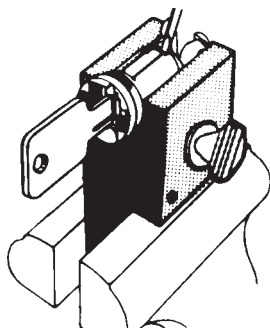

RFS-1

The tumbler retainers on GM Auto Locks must be staked out to prevent their popping out and causing unnecessary "lockouts".

This case hardened vise-held fixture, grips the core tightly without distortion while staking the four corners of the retainer with a small chisel-edge punch.

The rigid bottom holds without any giving or "bounce" as may occur with spring loaded, adjustable holder. It is also ideal for holding most other standard pin tumbler cylinder cores.

GM TUMBLER DECODER GAUGES

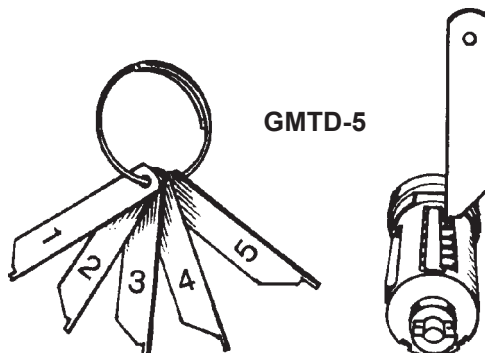

GMTD-5

This inexpensive set of gauges eliminates the guess work when reading the GM tumblers. No need to take apart the lock or waste key blanks by "eye-balling" the depths.

Simply press inward on the side bar and rake the tumblers, until the side bar moves inward to the unlocked position. Then place gauge pin over each wafer until the shoulder stop butts against the top of the plug.

AUTO LOCK CAP PLIERS

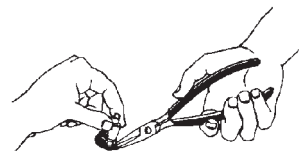

ALCP-10

Remove auto lock face caps easily in seconds. The specially machined tips grip like the jaws of a bulldog--and won't let go! Quickly removes either the factory lock caps using the rolled crimp, or the "Tab Style" replacement caps. Side cutters and cut fingers are now a thing of the past!

FOREIGN AUTO CAPS--With some care, it should be possible to remove these hard to replace foreign caps with minimum of distortion, allowing re-use of the removed cap.

These heavy duty forged pliers should give years of good service and are a valuable addition to your auto lock service department.

AUTO TOOLS

HPC

IGNITION DRILL TEMPLATE FOR FORD

ITF-14

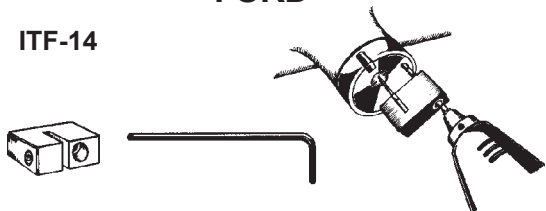

This template allows swift, precise removal of the sidebar so that replacement can be done almost immediately. Accuracy is ensured by the use of a key blank as a guide.

GATEWAY™ TOOLS

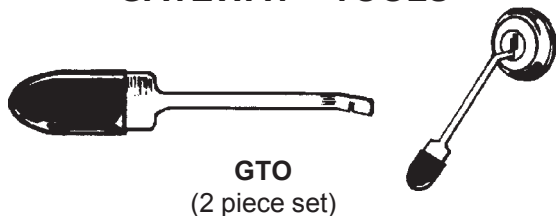

GTO
(2 piece set)

This revolutionary tool acts as a third hand to hold aside the dust cover on auto door locks, exposing the entire keyway, so that picking or extracting broken keys can be done more quickly and easily. Just insert into the door lock, turn in the direction the shutter opens to, and the lock is ready for service (with the Gateway securely held out of the way).

The universal slot size covers all of the major domestic manufacturers (GM, Ford, Chrysler and AMC), as well as many imports (BMW, Volkswagen, Toyota and Honda)

LAB

AUTO DISC TURNING TOOL



LB-LTT 005

FOR USE WITH:

- Auto Cylinders with dust covers
- Disc with wafer type cylinders

AUTO TOOLS



FOR REKEYING/REPAIRING AUTOMOTIVE LOCKS,
Everything you need for rekeying and repairing locks on most Chrysler, Ford, and GM vehicles. All components are available in convenient refill quantities. Packed in reusable, shatterproof plastic containers.

AL-A6500 AUTOMOTIVE "OOPS" KIT

		FORD 			
	CHRYSLER 				

AL-A6500

At last! "Grief relief" for the locksmith. A collection of the most needed (and sometimes hard to find) parts to complete the job. Compactly packaged in one handy unbreakable plastic box.

Refills (Qty per pkg.)

Part No.	Description	Qty.	Part No.	Description	Qty.
AL-A6501	Return Spring Chrysler, Trunk	10	AL-A6515	Scalp AMC, Doors	10
AL-A6502	"E" Ring Chrysler, Doors	10	AL-A6516	Scalp GM, Trunk	1
AL-A6503	Return Spring Chrysler, Trunk	10	AL-A6517	Scalp 1981 GM, Trunk	4
AL-A6504	Gasket Chrysler, Trunk	10	AL-A6518	Lock Clip GM, Tailgate	10
AL-A6505	Gasket Chrysler, Trunk	10	AL-A6519	Scalp GM, Trunk	4
AL-A6506	"E" Ring Ford, Doors	10	AL-A6520	Scalp, Black Chrome, GM, Door & Trunk	5
AL-A6507	Lock Clip GM, Doors	10	AL-A6521	Return Spring GM, Trunk	10
AL-A6508	Dust Cover Assembly GM, Doors and Trunk	10	AL-A6522	Gasket GM, Electric Trunk	10
AL-A6509	Gasket Ford, Doors	10	AL-A6523	Gasket GM, Doors	10
AL-A6510	Rod Retainer Ford, Doors	10	AL-A6524	Ignition Screw GM, Tilt and Tele. Column	4
AL-A6511	Return Spring Ford, Trunk	10	AL-A6525	Ignition Screw GM, Standard Column	4
AL-A6512	Lock Clip GM, Console	10	AL-A6526	Rod Retainer GM, Tailgate	6
AL-A6513	Dust Cover Spring AMC & GM, Doors & Trunk	100	AL-A6527	"O" Ring GM, Tailgate	10
AL-A6514	Scalp AMC, Tailgate	10	AL-A6528	Spring Clip GM, Doors	10
			AL-A6529	Gasket GM & Chrysler, Trunk	10
			AL-A6036	Scalp AMC & GM, Doors & Trunk	10

REPLACEMENT RETAINING CLIPS



AL-A6013

RETAINING CLIPS-Exact replacement retaining spring clips for Ford automotive locks. Fits all Ford trunk and door locks.



AL-A6032

RETAINING CLIPS-Exact replacement retaining spring clips for all General Motors, Chrysler and American Motors trunk and door locks.

AUTO TOOLS



FOR FORD

AL-A6000

To service door, trunk and ignition locks on all Ford Motor Company products 1965-on. Kit includes top and bottom pins, springs and retainers.

Refills (Qty per pkg.)

Part No.	Description	Qty.
AL-A6001	Top Tumbler #1	100
AL-A6002	Bottom Tumbler #1	100
AL-A6003	Top Tumbler #2	100
AL-A6004	Bottom Tumbler #2	100
AL-A6005	Top Tumbler #3	100
AL-A6006	Bottom Tumbler #3	100
AL-A6007	Top Tumbler #4	100
AL-A6008	Bottom Tumbler #4	100
AL-A6009	Top Tumbler #5	100
AL-A6010	Bottom Tumbler #5	100
AL-A6011	Spring	500
AL-A6012	Retainer	100
AL-A6014	Retainer	25

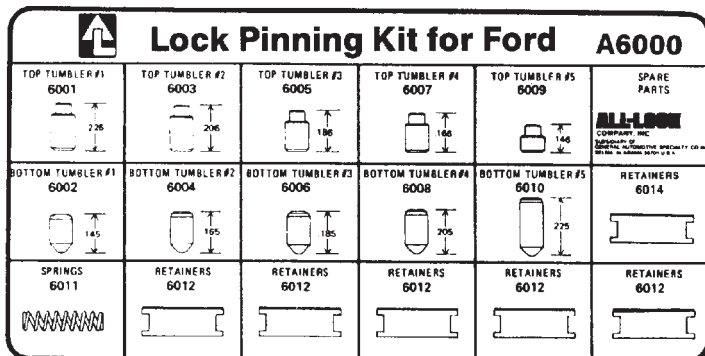

AL-A6060

Everything you need for rekeying and repairing locks on most Ford products from 1952-on with single bitted keys and breakaway tumblers.

Refills (Qty per pkg.)

Part No.	Description	Qty.
AL-A6061	Retainer	100
AL-A6062	Tumbler #1	100
AL-A6063	Tumbler #2	100
AL-A6064	Tumbler #3	100
AL-A6065	Tumbler #4	100
AL-A6066	Tumbler #5	100
AL-A6067	Spring	500

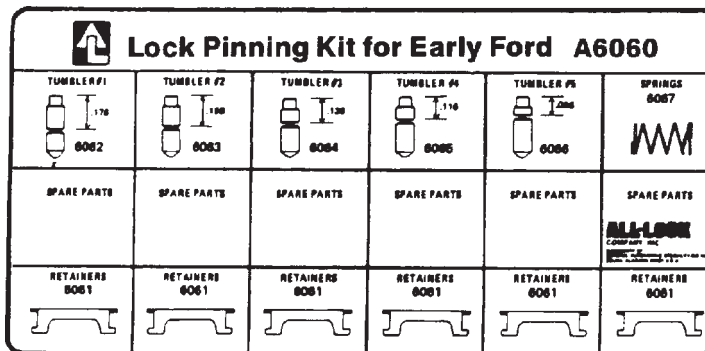

AL-A6100

To service ALL-LOCK 10 bitted Ford ignition locks.

Refills (Qty per pkg.)

Part No.	Description	Qty.
AL-A6101	Tumbler #1	75
AL-A6102	Tumbler #2	75
AL-A6103	Tumbler #3	75
AL-A6104	Tumbler #4	75
AL-A6105	Tumbler #5	75
AL-A6106	Tumbler Spring	100
AL-A6107	Pin Cover	50

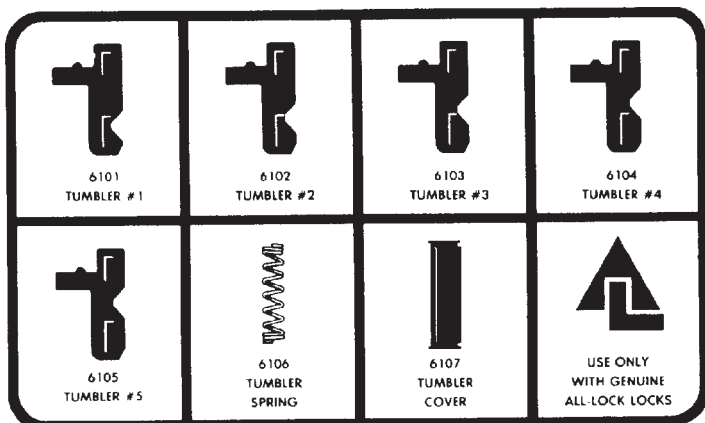

Refill and kit quantities subject to change without notice.

AUTO TOOLS



FOR FORD

6651 #1 TUMBLER OLD STYLE	6652 #2 TUMBLER OLD STYLE	6653 #3 TUMBLER OLD STYLE	6654 #4 TUMBLER OLD STYLE
6655 #5 TUMBLER OLD STYLE	6656 SPRINGS	6701 #1 TUMBLER NEW STYLE	6702 #2 TUMBLER NEW STYLE
6703 #3 TUMBLER NEW STYLE	6704 #4 TUMBLER NEW STYLE	6705 #5 TUMBLER NEW STYLE	SPARE PARTS

AL-A6700

Services Ford, Lincoln and Mercury 10 wafer door and trunk cylinders.

Refills (Qty per pkg.)



















Part No.	Description	Qty.
AL-A6651	Tumbler #1	50
AL-A6652	Tumbler #2	50
AL-A6653	Tumbler #3	50
AL-A6654	Tumbler #4	50
AL-A6655	Tumbler #5	50
AL-A6656	Tumbler Spring	200
AL-A6701	Tumbler #1	50
AL-A6702	Tumbler #2	50
AL-A6703	Tumbler #3	50
AL-A6704	Tumbler #4	50
AL-A6705	Tumbler #5	50

AL-A6725

Ford 10-bit face cap, door lock, tailpiece & dust cover assembly assortment.

Refills (Qty per pkg.)

Part No.	Description	Qty.
AL-A6657	Face cap	3
AL-A6658	Face cap	3
AL-A6660	Face cap	4
AL-A6726	Face cap	4
AL-A6727	Face cap	4
AL-A6728	Face cap	4
AL-A6729	Face cap	4
AL-A6730	Face cap	3
AL-A6731	Face cap	3
AL-A6732	Face cap	2
AL-A6733	Face cap	2
AL-A6734	Face cap	2
AL-A6735	Face cap	2
AL-A6736	Dust Cover Assembly	4
AL-A6737	Dust Cover Assembly	4
AL-A6738	Tail Piece	2
AL-A6739	Tail Piece	2
AL-A6740	Tail Piece	2

6657 FACE CAP  1986-90 TAURUS SABLE 1986-90 TEMPO TOPAZ MODELS WITHOUT LIGHTED KEYHOLE LEFT SIDE ONLY	6658 FACE CAP  1986-90 TEMPO TOPAZ MODELS WITHOUT LIGHTED KEYHOLE RIGHT SIDE ONLY	6660 FACE CAP  FITS 1984-12 UP MODELS 10 WAFFER TUMBLER LOCKS ROUND CHROME FACE	6726 FACE CAP  FITS 1984-12 UP MODELS 10 WAFFER TUMBLER LOCKS ROUND BLACK FACE	6727 FACE CAP  FITS 1984-12 UP MODELS 10 WAFFER TUMBLER LOCKS SQUARE CHROME FACE WITH LIGHTED KEYHOLE	6728 FACE CAP  FITS 1984-12 UP MODELS 10 WAFFER TUMBLER LOCKS SQUARE BLACK FACE WITH LIGHTED KEYHOLE
6729 FACE CAP  FITS 1984-12 UP MODELS 10 WAFFER TUMBLER LOCKS SQUARE CHROME FACE WITHOUT LIGHTED KEYHOLE	6730 FACE CAP  1986-90 TAURUS SABLE 1986-90 TEMPO TOPAZ MODELS WITH LIGHTED KEYHOLE RIGHT SIDE ONLY	6731 FACE CAP  1986-90 TAURUS SABLE 1986-90 TEMPO TOPAZ MODELS WITH LIGHTED KEYHOLE LEFT SIDE ONLY	6732 FACE CAP  1986-90 TEMPO TOPAZ MODELS WITHOUT LIGHTED KEYHOLE RIGHT SIDE ONLY	6733 FACE CAP  1986-90 TAURUS SABLE 1986-90 TAURUS MODELS WITHOUT LIGHTED KEYHOLE LEFT SIDE ONLY	6736 DUST COVER ASSEMBLY  FITS 1984-12 UP MODELS 10 WAFFER TUMBLER LOCKS CHROME
6734 FACE CAP  1986-90 TAURUS SABLE 1986-90 TAURUS MODELS WITH LIGHTED KEYHOLE RIGHT SIDE ONLY	6735 FACE CAP  1986-90 TAURUS SABLE 1986-90 TAURUS MODELS WITH LIGHTED KEYHOLE LEFT SIDE ONLY	6738 1984-12 UP DOOR LOCK TAILPIECE  MOST MODELS OF TAURUS SABLE TEMPO TOPAZ TAURUS COUGAR AND 1986-90 LINCOLN CONTINENTAL RIGHT SIDE ONLY	6739 1984-12 UP DOOR LOCK TAILPIECE  MOST MODELS OF TAURUS SABLE TEMPO TOPAZ TAURUS COUGAR AND 1986-90 LINCOLN CONTINENTAL LEFT SIDE ONLY	6740 1984-12 UP DOOR LOCK TAILPIECE  MOST MODELS OF ALDOUSAR ALDOUSAR 1986-90 LINCOLN CONTINENTAL 1986-90 LINCOLN CONTINENTAL SOME LOCKS WITH LIGHTED KEYHOLE RIGHT & LEFT SIDE	6737 DUST COVER ASSEMBLY  FITS 1984-12 UP MODELS 10 WAFFER TUMBLER LOCKS BLACK

AUTO TOOLS



FOR GENERAL MOTORS

Lock Service Kit for GM A6035					
TUMBLER #1 6038 	TUMBLER #2 6039 	TUMBLER #3 6040 	TUMBLER #4 6041 	TUMBLER #5 6042 	SPARE PARTS
TUMBLER SPRING 6043 	TUMBLER SPRING 6043 	TUMBLER SPRING 6043 	SPRING RETAINER 6037 	SPRING RETAINER 6037 	SPRING RETAINER 6037
FACE PLATE 6036 	FACE PLATE 6036 	FACE PLATE 6036 	FACE PLATE 6520 	FACE PLATE 6520 	SPARE PARTS

AL-A6035

To service door, trunk and ignition locks on all GM cars for all years. Kit includes face plates, tumblers, retainers and spring.

Refills (Qty per pkg.)

Part No.	Description	Qty.
AL-A6036	Face Plate	10
AL-A6037	Spring Retainer	100
AL-A6038	Tumbler #1	100
AL-A6039	Tumbler #2	100
AL-A6040	Tumbler #3	100
AL-A6041	Tumbler #4	100
AL-A6042	Tumbler #5	100
AL-A6043	Tumbler Spring	600
AL-A6520	Black Chrome Face Plate	5

6038 Tumbler #1 	6039 Tumbler #2 	6040 Tumbler #3 	6041 Tumbler #4 	6042 Tumbler #5 	6043 Tumbler Spring
1426U 	1428U 	1580U 	1575U 	1576U 	6037 Spring Retainer
Ignition Lock Cylinder All GM made cars with locking steering columns without retaining bolt... 1970-78	Ignition Lock Cylinder GM Products with retaining screw... 1978-97	Door Lock Fits many Buick, Cadillac, Chevrolet, Pontiac & Oldsmobile... 1974-ON	Trunk Lock Fits on the trunk lid, not on the body.	Trunk Lock Fits on the body, not on the trunk lid.	

AL-A6175

For "Kwik" one stop service or replacement of most popular GM locks.

Refills (Qty per pkg.)

Part No.	Description	Qty.
AL-A6037	Spring Retainer	100
AL-A6038	Tumbler #1	100
AL-A6039	Tumbler #2	100
AL-A6040	Tumbler #3	100
AL-A6041	Tumbler #4	100
AL-A6042	Tumbler #5	100
AL-A6043	Tumbler Spring	600
AL-1426U	Ignition Lock Cylinder	1
AL-1428U	Ignition Lock Cylinder	1
AL-1580U	Door Lock	1
AL-1575U	Trunk Lock	1
AL-1576U	Trunk Lock	1

BLACK 6255	BLACK 6255	BLUE 6256	GRAY 6257	RED 6258	
BLACK 6251	BLACK 6251	BLUE 6252	GRAY 6253	RED 6254	

AL-A6250

GM Key Cover Kit. Color coded, snap-on plastic covers identify and dress-up regular GM style blanks.

Refills (Qty per pkg.)

Part No.	Description	Qty.
AL-A6251	Black Secondary	50
AL-A6252	Blue Secondary	25
AL-A6253	Gray Secondary	25
AL-A6254	Red Secondary	25
AL-A6255	Black Primary	50
AL-A6256	Blue Primary	25
AL-A6257	Gray Primary	25
AL-A6258	Red Primary	25











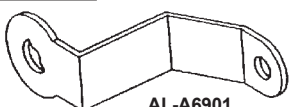



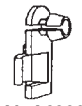

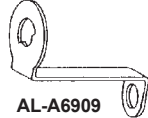



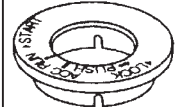
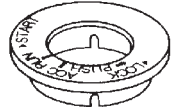
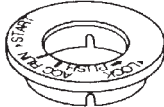

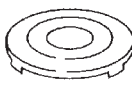
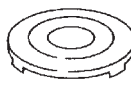

Refill and kit quantities subject to change without notice.

AUTO TOOLS



ALL-LOCK

FOR SATURN









 AL-A6901					
 AL-A6902	 AL-A6903	 AL-A6904	 AL-A6905	 AL-A6906	
 AL-A6907	 AL-A6908	 AL-A6909	 AL-A6910	 AL-A6911	 AL-A6912
 AL-A6913	 AL-A6913	 AL-A6913	 AL-A6914	 AL-A6914	 AL-A6915
 AL-A6916	 AL-A6916	 AL-A6917	 AL-A6917	 AL-A6918	 AL-A6919
 AL-A6920	 AL-A6921	 AL-A6922	 AL-A6923	 AL-A6924	 AL-A6925

AL-A6900
For servicing Saturn Automobiles.

KIT CONTAINS:

Stock#	Qty	Stock#	Qty	Stock#	Qty	Stock#	Qty
AL-A6901	5	AL-A6907	5	AL-A6913	3	AL-A6919	50
AL-A6902	4	AL-A6908	5	AL-A6914	6	AL-A6920	50
AL-A6903	4	AL-A6909	5	AL-A6915	50	AL-A6921	50
AL-A6904	5	AL-A6910	50	AL-A6916	6	AL-A6922	50
AL-A6905	4	AL-A6911	10	AL-A6917	6	AL-A6923	50
AL-A6906	6	AL-A6912	10	AL-A6918	10	AL-A6924	50
						AL-A6925	50

FOR CHRYSLER

6151 TUMBLER #1	6152 TUMBLER #2	6153 TUMBLER #3	6154 TUMBLER #4
			
6155 TUMBLER #5	6156 TUMBLER #6	6157 TUMBLER SPRING	6158 PIN COVER
			

AL-A6150
Chrysler side bar lock service kit.

Refills (Qty per pkg.)

Part No.	Description	Qty.
AL-A6151	Tumbler #1	100
AL-A6152	Tumbler #2	100
AL-A6153	Tumbler #3	100
AL-A6154	Tumbler #4	100
AL-A6155	Tumbler #5	100
AL-A6156	Tumbler #6	100
AL-A6157	Tumbler Spring	200
AL-A6158	Pin Cover	25

AUTO TOOLS



FOR CHRYSLER

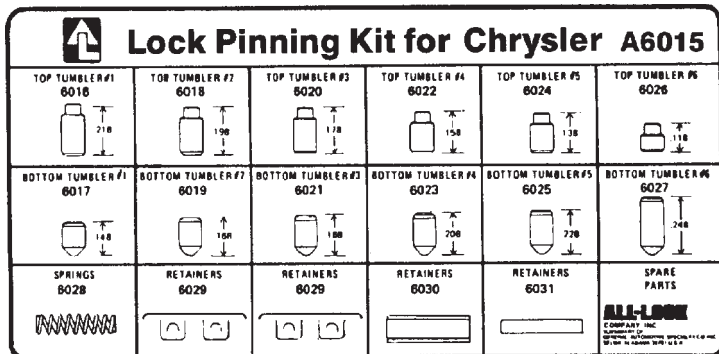

AL-A6015

To service door, trunk and ignition lock on Chrysler cars. Kit includes face plates, tumblers, retainers and springs.

Refills (Qty per pkg.)

Part No.	Description	Qty.
AL-A6016	Top Tumbler #1	100
AL-A6017	Bottom Tumbler #1	100
AL-A6018	Top Tumbler #2	100
AL-A6019	Bottom Tumbler #2	100
AL-A6020	Top Tumbler #3	100
AL-A6021	Bottom Tumbler #3	100
AL-A6022	Top Tumbler #4	100
AL-A6023	Bottom Tumbler #4	100
AL-A6024	Top Tumbler #5	100
AL-A6025	Bottom Tumbler #5	100
AL-A6026	Top Tumbler #6	100
AL-A6027	Bottom Tumbler #6	100
AL-A6028	Spring	500
AL-A6029	Retainer/Door Locks	30
AL-A6030	Retainer/Ignition Locks	15
AL-A6031	Retainer/Trunk Locks	15

AL-A6200

Chrysler double bit door and trunk service kit.

Refills (Qty per pkg.)

Part No.	Description	Qty.
AL-A6201	Tumbler #1	50
AL-A6202	Tumbler #2	50
AL-A6203	Tumbler #3	50
AL-A6204	Tumbler #4	50
AL-A6205	Tumbler Spring	50
AL-A6206	Spring Pin	5
AL-A6207	Cap Spring	50
AL-A6208	D/C Assembly	5
AL-A6820	D/C Assembly	5
AL-A6210	"E" Ring	5
AL-A6211	Lever	2
AL-A6212	Return Spring	5
AL-A6213	Return Spring	5
AL-A6214	Trunk Cap	5
AL-A6215	Door Cap	5
AL-A6209	Lever	2
AL-A6216	Lever	2
AL-A6217	Lever	2
AL-A6218	Door Cap	5
AL-A6219	Door Cap	5
AL-A6220	Door Cap	5
AL-A6221	Trunk Cap	5

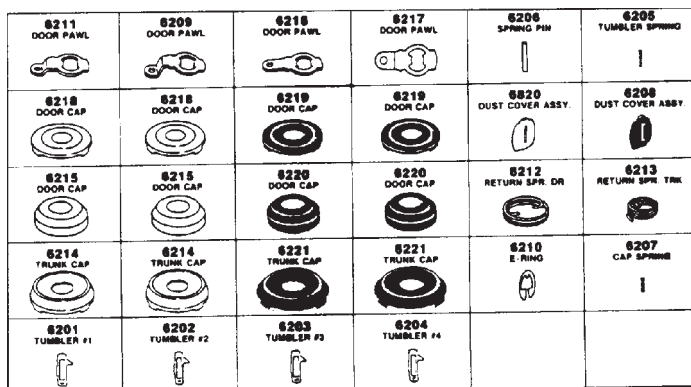

Refill and kit quantities subject to change without notice.

AUTO TOOLS



FOR JAPANESE

6751 TOYOTA, MITSUBISHI AND OTHERS	6752 TOYOTA, ISUZU MITSUBISHI	6753 TOYOTA 83-UP SPECTRUM, NOVA, MITSUBISHI, COLT & ISUZU 1985-UP	6754 TOYOTA TRUNK, ISUZU, OPEL, SUZUKI, SPRINT DOOR & TRUNK	6755 TOYOTA & IMPULSE TRUNK, ISUZU, OPEL, SPRINT & LUV DOOR	6756 TOYOTA, MITSUBISHI, COLT, DOOR & TRUNK
6757 HONDA DOOR INTEGRA 86-UP, PRELUDE 83-UP, ACCORD LX 86-UP, LEGEND 86-UP	6758 HONDA ACCORD DOOR & TRUNK 1986-UP CIVIC DOOR 86-87	6759 HONDA & Acura TRUNK, INTEGRA	6760 HONDA DOOR 1979-81 ACCORD, CIVIC DOOR & TRUNK 1980-UP	6761 HONDA TRUNK 1983-UP, PRELUDE HONDA DOOR 1984-UP, CIVIC	6762 HONDA DOOR 1982-85 ACCORD
6763 HONDA DOOR 1984-UP	6764 HONDA TRUNK 1982-85 ACCORD 1984-UP CIVIC	6765 HONDA TRUNK 1988-UP	6766 HONDA PRELUDE TRUNK 1979-82	6767 DATSUN SUBARU	6768 DOOR & TRUNK 1982-UP DATSUN 1975-UP SUBARU
6769 DATSUN, SUBARU	6770 FORD PROBE DOOR	6771 FORD PROBE TRUNK			

AL-A6750

Foreign Car Cap Kit for Nissan/Datsun, Honda, Toyota, Subaru, Integra, Legend, Mitsubishi, Isuzu, Sprint, Luv, Opel, Spectrum, Nova and Colt.

Refills (Qty per pkg.)

Part No.	Description	Qty.
AL-A6751	Toyota Face Cap	5
AL-A6752	Toyota Face Cap	5
AL-A6753	Toyota Face Cap	5
AL-A6754	Toyota Face Cap	5
AL-A6755	Toyota Face Cap	5
AL-A6756	Toyota Face Cap	5
AL-A6757	Honda Face Cap	5
AL-A6758	Honda Face Cap	5
AL-A6759	Honda Face Cap	5
AL-A6760	Honda Face Cap	5
AL-A6761	Honda Face Cap	5
AL-A6762	Honda Face Cap	5
AL-A6763	Honda Face Cap	5
AL-A6764	Honda Face Cap	5
AL-A6765	Honda Face Cap	5
AL-A6766	Honda Face Cap	5
AL-A6767	Datsun-Subaru Face Cap	5
AL-A6768	Datsun-Subaru Face Cap	5
AL-A6769	Datsun-Subaru Face Cap	5
AL-A6770	Ford Face Cap	5
AL-A6771	Ford Face Cap	5

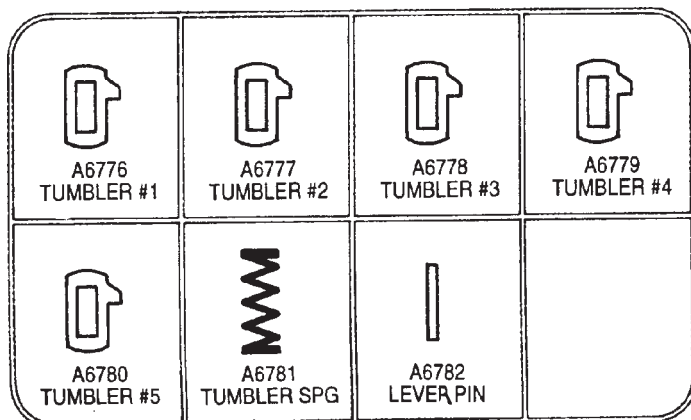

AL-A6775

Mazda Service Kit for MPV van, 323 2dr hatchback, 626 and 929 w/auto trans, MX-6, Suzuki Sidekick, Suzuki Samurai, Geo Tracker.

KIT CONTAINS:

Part No.	Description	Qty.
AL-A6776	Tumbler #1	50
AL-A6777	Tumbler #2	50
AL-A6778	Tumbler #3	50
AL-A6779	Tumbler #4	50
AL-A6780	Tumbler #5	50
AL-A6781	Tumbler Springs	100
AL-A6782	Lever Pin	10

Refill and kit quantities subject to change without notice.

AUTO TOOLS



FOR JAPANESE

TOYOTA F, K, P, R, S CODE SERIES					
1988 TOYOTA, DAIHATSU AND 1989 MITSUBISHI					
TOYOTA 30001-2878 CODE SERIES					
TOYOTA 30001-2878			TOYOTA VANS AND STATION WAGONS		TOYOTA CAMRY
TOYOTA K7000-9000 CODE SERIES				TOYOTA CAMRY 1992-93 CODE SERIES 10001-19001	
TOYOTA CAMRY 1992-93 CODE SERIES 10001-19001					

AL-A6800

Toyota Tumbler Kit services most Toyotas 1970-on, as well as Hyundai, Isuzu, Suzuki, Honda Cycles, Mitsubishi, Colt, Daihatsu, Sprint, Spectrum, Nova, and Luv. Also services Camry with split tumblers.

Refills (Qty per pkg.)

Part No.	Description	Qty.
AL-A6541	Tumbler #4	50
AL-A6542	Tumbler #3	50
AL-A6543	Tumbler #2	50
AL-A6544	Tumbler #1	50
AL-A6546	Tumbler Springs	200
AL-A6555	Retainer	20
AL-A6556	Retainer	20
AL-A6801	Tumbler #1	50
AL-A6802	Tumbler #2	50
AL-A6803	Tumbler #3	50
AL-A6804	Tumbler #4	50
AL-A6805	Tumbler #1	50
AL-A6806	Tumbler #2	50
AL-A6807	Tumbler #3	50
AL-A6808	Tumbler #4	50
AL-A6809	Tumbler #5	50
AL-A6810	Tumbler #6	50
AL-A6811	Tumbler #7	50
AL-A6812	Tumbler #1	50
AL-A6813	Tumbler #2	50
AL-A6814	Tumbler #3	50
AL-A6815	Tumbler #4	50
AL-A6816	Tumbler #1	50
AL-A6817	Tumbler #2	50
AL-A6818	Tumbler #3	50
AL-A6819	Tumbler #4	50

Part No.	Description	Qty.
AL-A6822	Tumbler Spring	200
AL-A6823	Camry Tumbler #4	50
AL-A6824	Camry Half Tumbler #1	50
AL-A6825	Camry Half Tumbler #2	50
AL-A6826	Camry Half Tumbler #3	50
AL-A6827	Camry Half Tumbler #4	50
AL-A6828	Camry Tumbler Spring	200
AL-A6829	Camry Tumbler #1	50
AL-A6830	Camry Tumbler #2	50
AL-A6831	Camry Tumbler #3	50

AL-A6950

Foreign Lock Pawl and Clip Service Kit.

KIT CONTAINS:

Part No.	Description	Qty.
AL-A6951	4700 L.H. Lever	2
AL-A6952	4700 R.H. Lever	2
AL-A6953	4786 Lever	2
AL-A6954	4766 Lever	2
AL-A6955	4767 Lever	2
AL-A6956	4727 Lever	2
AL-A6957	4726 L.H. Lever	2
AL-A6958	4726 R.H. Lever	2
AL-A6959	4701 L.H. Lever	2
AL-A6960	4701 R.H. Lever	2
AL-A6961	4776 Lever	2
AL-A6962	4785 Lever	2
AL-A6963	4700 E-Clip	2
AL-A6964	4786 E-Clip	2
AL-A6965	4701 E-Clip	2