

OWNER'S MANUAL

Öhlins front fork Superbike FGR 800



Important information concerning safety is distinguished in this manual by the following notations:



This Safety alert symbol means: Caution! Your safety is involved.

WARNING!

Failure to follow warning instructions could result in severe or fatal injury to anyone working with, inspecting or using the suspension, or to bystanders.

CAUTION!

Caution indicates that special precautions must be taken to avoid damage to the suspension.

NOTE!

This indicates information that is of importance with regard to procedures.

WARNING!

1. Installing a suspension, that is not approved by the vehicle manufacturer, may affect the stability of your vehicle. Öhlins Racing AB cannot be held responsible for any personal injury or damage whatsoever that may occur after fitting the suspension. Contact an Öhlins dealer for advice.

2. Please study and make certain that you fully understand the contents in the mounting instruction(s) and the owner's manual(s) before handling this suspension kit. If you have any questions regarding installation procedures, contact an Öhlins dealer.

3. The vehicle service manual must be referred to when installing the Öhlins suspension.

Introduction

All of Öhlins advanced suspension products are adapted to the brand and model. This means that length, travel spring action and damping characteristics, are tested individually just for the motorcycle that you have decided to fit with Öhlins suspension.

Before installation

Öhlins Racing AB can not be held responsible for any damage whatsoever to suspension or vehicle, or injury to persons, if the instructions for fitting and maintenance are not followed exactly. Similarly, the warranty will become null and void if the instructions are not adhered to.

NOTE!

Öhlins products are subject to continual improvement and development. Consequently, although these instructions include the most up-to-date information available at the time of printing, there may be minor differences between your suspension and this manual. Please consult your Öhlins dealer if you have any questions with regard to the contents of the manual.

NOTE!

During storage and transportation, especially at high ambient temperature, the oil and grease used for assembling may run out inside the packing and damage the expanded polystyrene packing material. This is not unusual and is in no way detrimental to the suspension.

Öhlins Front Fork FGR 800

The FGR800 is very essence of front fork technology and is based on last years succesful predecessor FGR700. This pressurized front fork, equipped with TTX technology is the very latest in front fork technology. The new improved FGR800 comes fully packed with technical solutions and experiences gained from MotoGP, WSB and AMA racing.

Features:

- New fork bottoms and inner fork legs for improved rigidity.
- New valve specification with better dynamic behavior for faster damping response, resulting in improved feedback of the tire-contact feeling.
- New bushings with new material and less play for smoother action.
- New volume spacer for less fluid in the fork to reduce flex in the fluid for improved damping response.
- Improved internal seals and surfaces for simplified maintenance.

NOTE!

- *Read through the whole work section and make sure that you understand all the steps in the procedure before you begin.*
- *Make sure that you have all the proper tools needed for the section you are about to work on, before you begin.*
- *Clean all parts thoroughly after disassembling.*
- *Contact an Öhlins dealer if you have any questions regarding the front fork.*

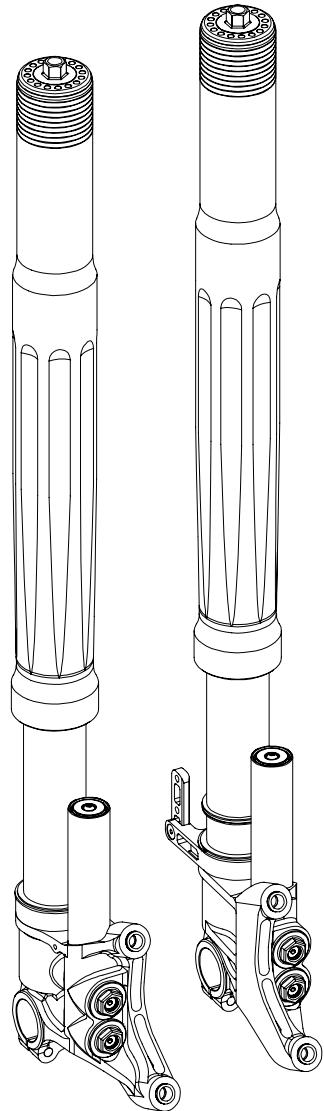

Contents

Safety precautions	2	3. Replace the seal	11
Öhlins front fork FGR800	3	4. Replace inner/outer fork leg	12
Work shop section		5. Disassemble the shaft	13
Contents	4	6. Assemble the front fork	14
Tools	5	7. Revalve	16
External adjustments	6	Oil level adjustments	17
Setting up your fork	7	Troubleshooting	18
1. Change the spring	8	Technical info	19
2. Disassemble the front fork	9	Spare parts list	20

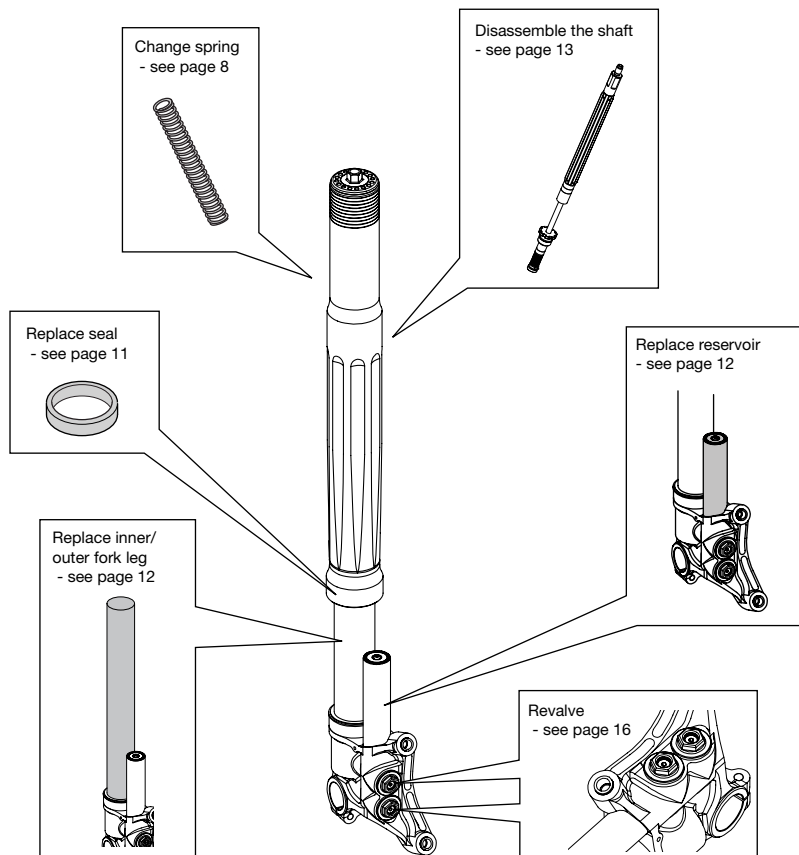

Pos.	Art. No	Description	Remarks
1	00727-02	Vice with soft jaws	
2		Wrench	14 mm
		Wrench	17 mm
		Wrench	19 mm
3		Allen key	
4		Wire with hook	
5		Heat gun	
6		Teflon tape	
7		Brass wire brush	
8	00797-01	Sleeve pin	
9	01797-04	Seal head tool	
10	01765-03	Pull up tool	
11	00720-02	Measure pin	
12	00720-03	Pin tool	
13	00786-05	Soft jaws clamp	ø 43
14	00786-07	Soft jaws clamp	ø 29
15	00715-01	Sharp screw driver	
16	02810-01	Pull up holder tool	
17	01781-01	Gas filling device	
18	01309-01	Öhlins front fork oil	
19	00146-01	Öhlins red grease	
20	00147-01	Öhlins white grease	
21		Rag	
22		Waste oil container	
23	01757-01	Attachment bar tool	
24	01759-07	Bushing tool	
	01759-08	Bushing tool	
25	01758-04	Bar guide	
		Loctite 648	
		Loctite 222	

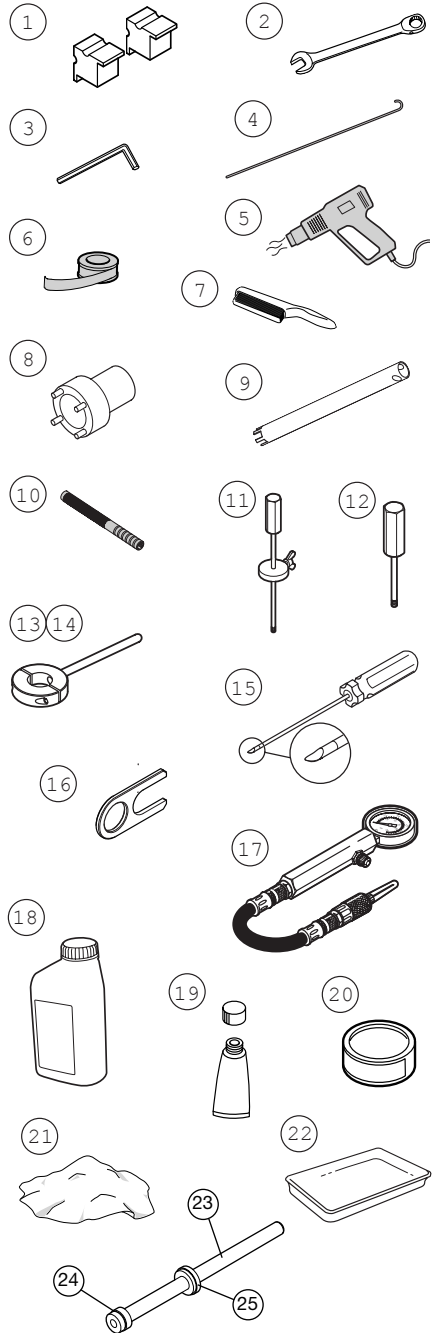

This Öhlins superbike front fork is equipped with the following external adjusters:

Spring preload adjustment

Adjust the spring preload by turning the nut on the top of the fork leg.
Use a 14 mm wrench.

The adjustment range is 0-18 mm.

1 turn on the adjustment nut will change 1 mm in spring preload.

Recommended static sag is 25-30 mm.

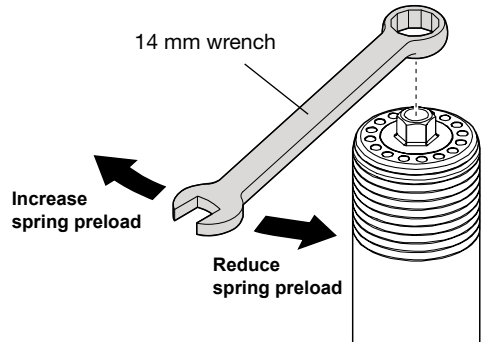

Rebound adjustment and Compression adjustment

Adjust the rebound or compression damping by turning the adjuster screw(s) at the fork bottom. Use tool 00794-01.

The adjustment range from closed valve (clockwise) to maximum open valve (counter clockwise) is 20 "clicks".

Recommended adjustment "clicks" from closed position: See specification card.

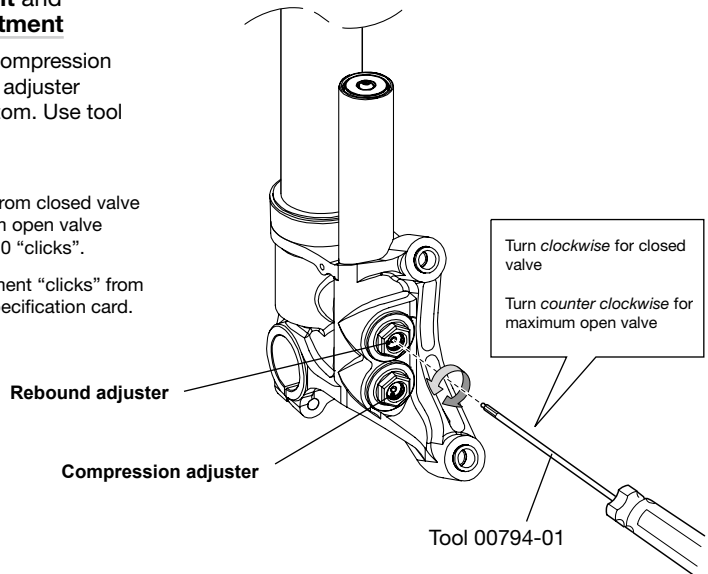

Basic Guidelines

How to set up your Öhlins front fork

The front fork is just one part of your motorcycle. To get it to work properly, set up your motorcycle according to your vehicle service manual.

1

Put your motorcycle on a workstand and install the Öhlins front fork according to your vehicle service manual.

NOTE!

The lower triple clamp must not be tightened to more than 12-15 Nm. This is also important for the steering damper bracket, when located around the upper front leg. Too high torque may deform the front fork leg.

Guidelines

Setting the Spring preload

2

The spring preload is very important since it affects the height of the motorcycle and the fork angle. Consequently, handling characteristics can be changed, even negatively.

Procedure

We recommend you to have an assistant for this procedure.

1. Put the motorcycle on a stand.
2. Make sure that the shock absorber is fully extended.
3. Measure the distance from a point marked by a piece of tape, immediately above the rear wheel axle, to the wheel axle. (R1)
4. Make a similar measurement on the front axle, for example, from the bottom of the upper fork crown to the front wheel axle. (F1)
5. Take the same measurements with the rider and equipment on the motorcycle. It is important that the rider has a correct riding posture, so that the weight is balanced on the front and rear wheel in the same way as when riding (R3, F3).

3

The measurements should not differ from the following:

Rear: 30±5 mm (R1-R3)

Front: 30±5 mm (F1-F3)

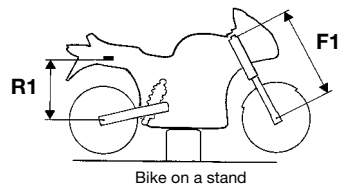

Bike on a stand

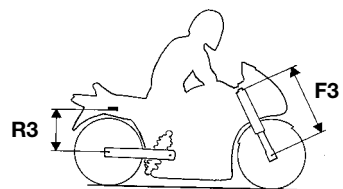

Bike with rider on

1.1

Release the spring preload completely by turning the adjustment nut counter clockwise as far as possible. Use a 14 mm wrench or socket.

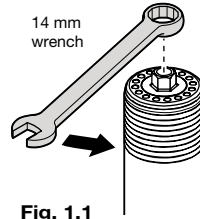

Fig. 1.1

1.2

Loosen the screws that hold the fork legs in the upper triple clamps.

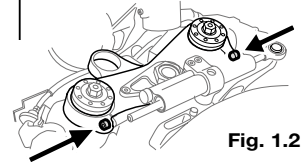

Fig. 1.2

1.3

Loosen the top cap assembly from the outer fork leg. Use tool 00797-01.

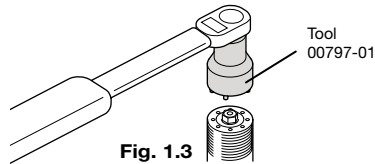

Fig. 1.3

1.4

Remove the top cap assembly from the shaft. Use a 14 mm wrench on the top cap and a 19 mm on the shaft.

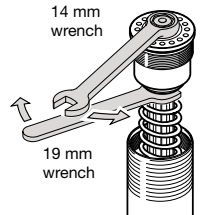

Fig. 1.4

1.5

Remove the spring support and the spring. Use a wire with a hook and carefully pull up the preload tube.

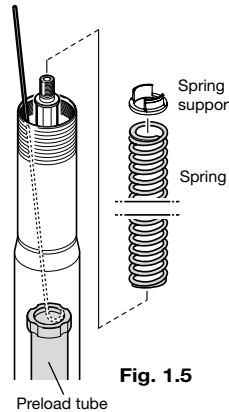

Fig. 1.5

1.6

Check the oil level according to Chapter **Oil level adjustment**.

NOTE!

Use *Öhlins Front fork oil 01309-01 only*.

1.7

Reinstall the preload tube, the *new* spring and the spring support.

1.8

Reinstall the top cap assembly to the shaft with tightening torque 20 Nm.

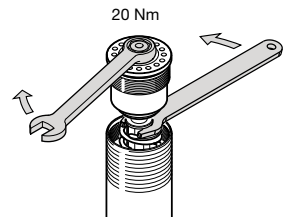

Fig. 1.8

1.9

Reinstall the top cap into the outer fork leg, with the front wheel off the ground (use tool 00797-01) and tighten with torque 10 Nm. Tighten the upper triple clamps and adjust the preload according to Chapter **External adjustments**.

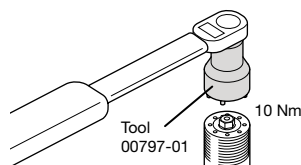

Fig. 1.9

NOTE!

This worksection can not be done while the fork still is installed on the motorcycle.

2.1

Fasten the fork leg in a vice with soft jaws.

2.2

Release the spring preload completely by turning the adjustment nut counter clockwise as far as possible. Use a 14 mm wrench or a socket.

NOTE!

Do not use the preload adjuster to tighten or loosen the top cap assembly.

2.3

Loosen the top cap assembly from the outer fork leg. Use tool 00797-01.

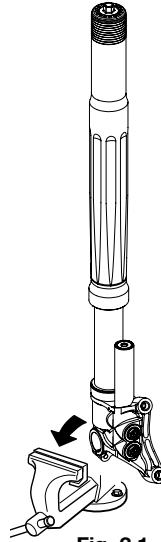

Fig. 2.1

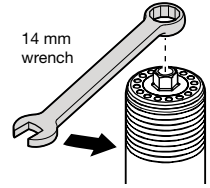

Fig. 2.2

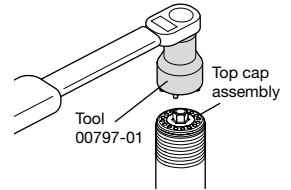

Fig. 2.3

2.4

Remove the top cap assembly from the shaft assembly. Use a 14 mm wrench on the top cap and a 19 mm wrench on the shaft.

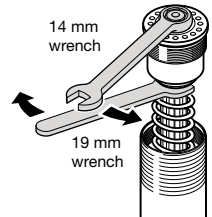

Fig. 2.4

2.5

Remove the spring support and the spring. Use a wire with a hook to carefully pull up the preload tube.

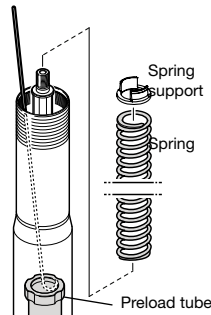

Fig. 2.5

2.6

Remove the screw and the o-ring from the reservoir end.

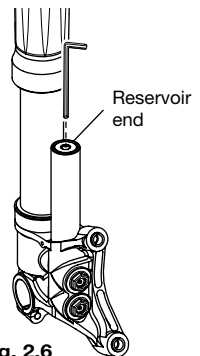

Fig. 2.6

NOTE!

Before releasing the gas pressure, count and note the adjuster settings. Also check that the gas pressure is correct. Then the adjusters should be set in a fully open position.

⚠ WARNING!

Releasing high pressure gas from the front fork can be hazardous. Do not perform any kind of service until gas pressure is completely released.

2.7

Release the nitrogen gas by inserting an injection needle in the reservoir end through the rubber valve.

2.8

Press down the reservoir end to remove the circlip. Use tool 00720-03.

2.9

Remove the reservoir end. Use tool 00720-03.

2.10

Remove the gas piston, use tool 00720-02.

2.11

Use tool 01797-04 and 01765-03 to remove the shaft assembly from the fork leg.

2.12

Drain all oil from the fork leg.

2.13

Disassemble the shaft assembly according to Chapter **Disassemble the shaft**.

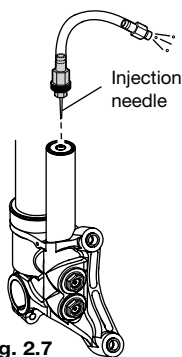

Fig. 2.7

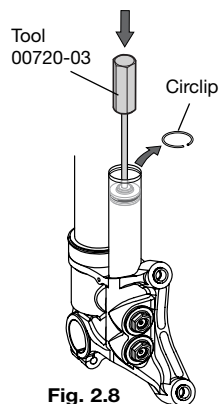

Fig. 2.8

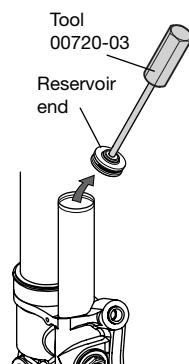

Fig. 2.9

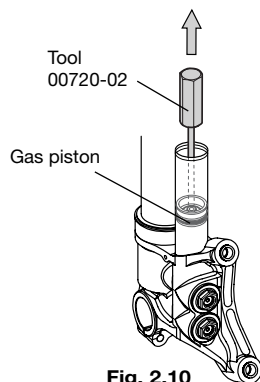

Fig. 2.10

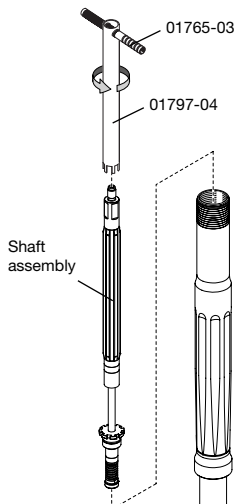

Fig. 2.11

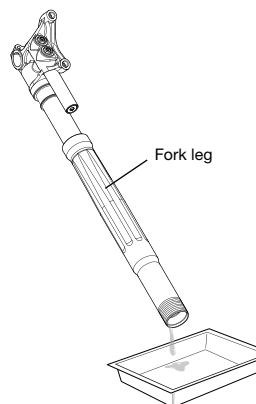

Fig. 2.12

NOTE!

This worksection can not be done while the fork still is installed on the motorcycle.

Remove the top cap and shaft assembly according to Chapter **Disassemble the Front Fork**. Then, continue below.

3.1

Remove the outer fork leg, clean the seal and check the condition. If the seal is in good condition apply some red grease (00146-01) to the seal before reassembling the fork. **A damaged seal must be replaced!**

3.2

Remove the circlip, the seal and finally the washer.

3.3

Apply a thin layer of Öhlins red grease (00146-01) to the washer and to the sealing surfaces of the fork seal. Install the washer and the seal into the outer fork leg. Install the circlip into the groove.

NOTE!

It is important to use the correct grease in order to achieve optimum fork function.

3.4

Apply some Öhlins fork oil (01309-01) on the inner fork leg's outer surface. Slide on the outer fork leg carefully on to the inner fork leg (completely down).

⚠ WARNING!

Be careful - Do not damage the fork seal!

3.5

Reassemble the fork legs according to Chapter **Assemble the Front fork**.

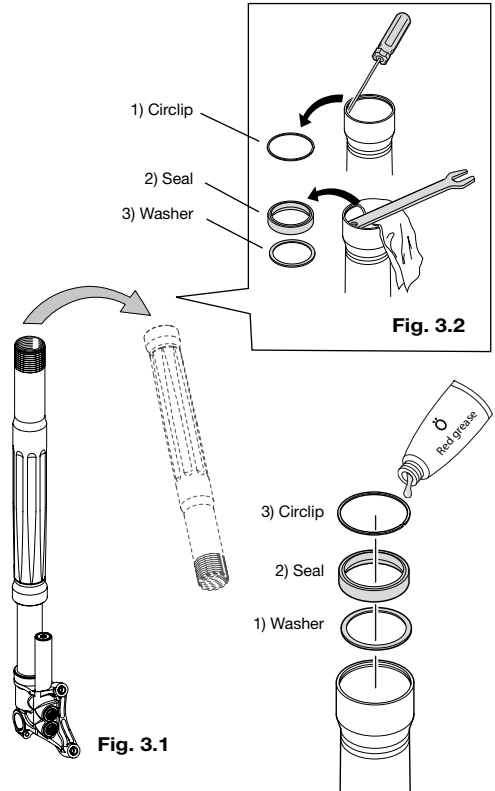

Fig. 3.1

Fig. 3.2

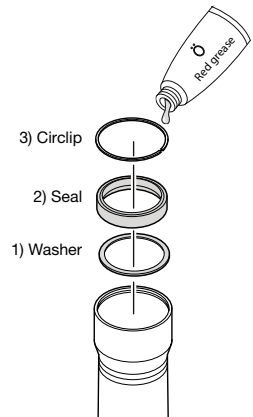

Fig. 3.3

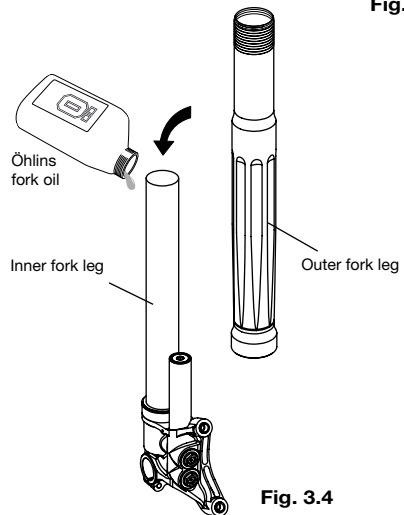

Fig. 3.4

NOTE!

This worksection can not be done while the fork still is installed on the motorcycle.

Remove the top cap and shaft assembly according to Chapter **Disassemble the Front Fork**. Then, continue below.

4.1

Remove the outer fork leg.

4.2

Use a heat gun to warm up the fork bottom. Install tool 00786-02, just above the lower $\varnothing 5$ mm oil bleed hole, to unscrew and remove the inner fork leg. Clean the thread thoroughly from Loctite. We recommend to change the o-rings!

4.3

Use a heat gun to carefully warm up the reservoir tube bottom. Use tool 00786-07 to unscrew and remove the reservoir tube. Clean the threads thoroughly from Loctite. We recommend to change the o-rings!

4.4

Install the *new* reservoir tube using tool 00786-07. Use Loctite 222 on the threads. Tightening torque 25 Nm.

4.5

Install the *new* inner fork leg using tool 00786-02. Use Loctite 2701 on the threads. Tightening torque 160 Nm.

4.6

Apply some Öhlins fork oil (01309-01) on the inner fork leg's outer surface. Slide on the outer fork leg carefully on to the inner fork leg (completely down).

⚠ WARNING!

Be careful - Do not damage the fork seal!

4.7

Reassemble the fork legs according to Chapter **Assemble the Front Fork**.

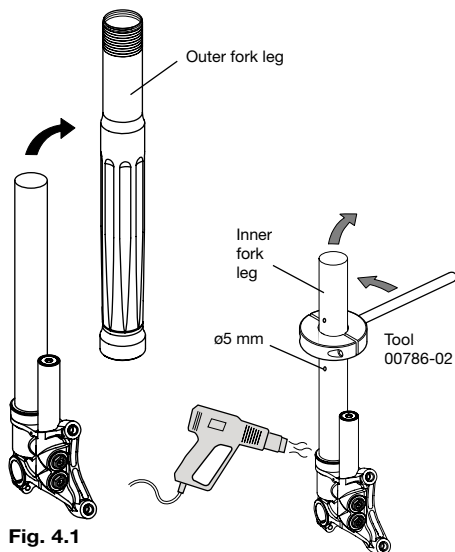
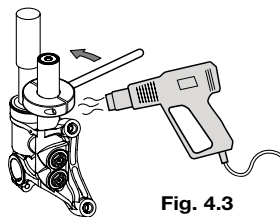
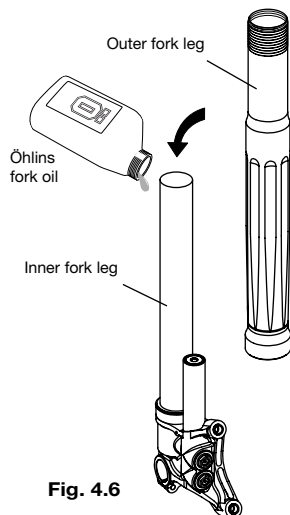
**Fig. 4.1****Fig. 4.2****Fig. 4.3****Fig. 4.6**

Remove the fork leg from the motorcycle.
Remove the top cap and shaft assembly according to steps 1-7 in chapter Disassemble the Front Fork. Then, continue below.

5.1

Put the shaft assembly in a vice using soft jaws 00727-02. Remove the piston, top-out spring and sleeve in one unit. Use a 16 mm wrench.

CAUTION!

Do not tighten the jaws too hard, the shaft can be damaged.

5.2

Remove the spacer and the o-ring.

5.3

Remove the seal head from the shaft. Check the support ring, x-ring and the o-ring. Replace them if necessary. Use plenty of white grease when installing a x-ring.

5.5

Wrap some teflon tape around the shaft thread to protect the x-ring from damages. Apply some red grease on the tape and the shaft end. Reinstall the seal head on the shaft.

5.6

Use a brass wire brush to clean the shaft from tape. Reinstall the o-ring, spacer, sleeve, topout spring and piston. Tighten the piston with torque 8 Nm. Use Loctite 2701 and a 16 mm wrench.

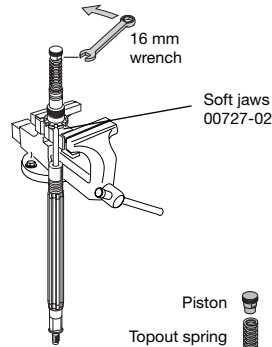

Fig. 5.1

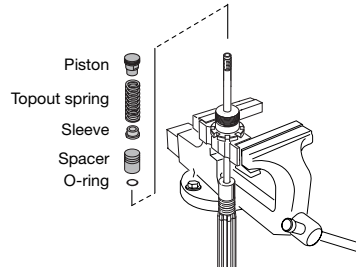

Fig. 5.2

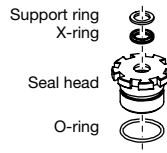

Fig. 5.3

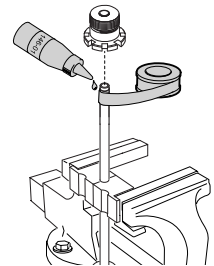

Fig. 5.5

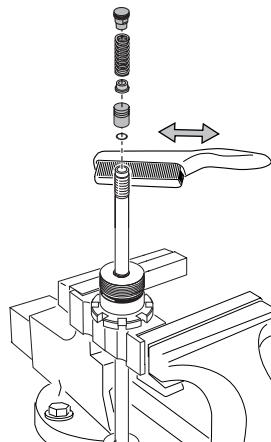

Fig. 5.6

6.1

Open the compression and rebound adjusters completely. Pour Öhlins front fork oil 01309-01 to the top edge of the reservoir. Carefully continue to fill until the oil level is the same in the reservoir and the cylinder tube.

6.2

Push the gas piston, with the teflon band and o-ring installed, to the reservoir bottom. Use tool 00720-02. Do not allow the gas piston to be pushed back over the circlip groove. Make sure that there is no air between the piston and the oil.

6.3

Fill the inner fork leg with oil to approximately 20-30 mm above the cylinder tube.

6.4

Carefully pump the gas piston up and down 10-20 times to bleed the system.

6.5

Check the o-ring on the reservoir end cap and replace it if necessary. Install the reservoir end cap into the reservoir tube using tool 00720-03. Reinstall the circlip. Make sure that it stops in the intended groove.

NOTE!

Nitrogen (N2) gas. Use pressure gauge (01781-01)

⚠ WARNING!

Use of inflammable gas for pressurising the shock absorber can be hazardous. Use nitrogen gas (N2) only!

6.6

Dip the needle of the gas tool (01781-01) in red grease and insert the needle through the gas filler valve. Charge with gas to the correct pressure, according to the spec. card.

NOTE!

Ensure that there is no leakage of gas or fluid.

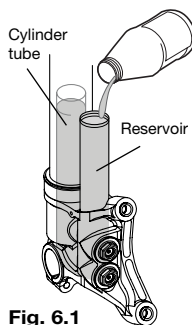

Fig. 6.1

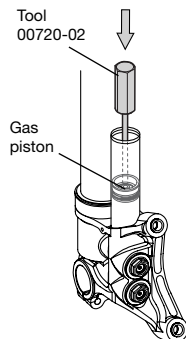

Fig. 6.2

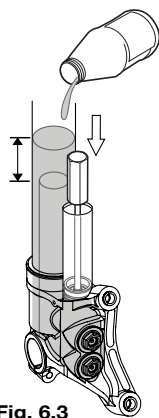

Fig. 6.3

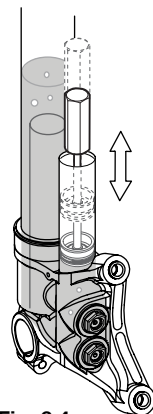

Fig. 6.4

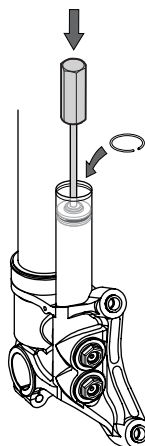

Fig. 6.5

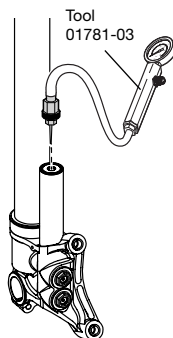

Fig. 6.6

6.7

Install seal head tool 01797-04 and pull-up tool 01765-03 on the shaft assembly. Pull the pull-up tool and push the seal head tool at the same time to contract the top out spring. Install tool 02810-01 on tool 01765-03 to keep the contraction. Apply red grease to the seal head thread.

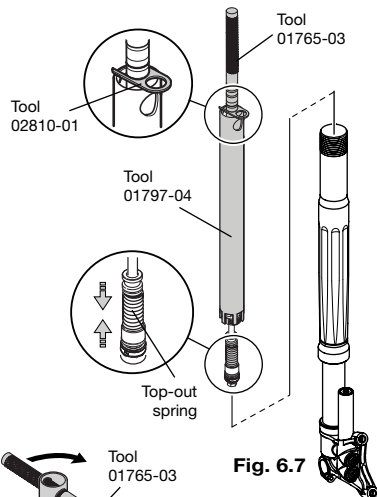

Fig. 6.7

6.8

Assemble the complete shaft assembly into the cylinder tube. Tighten it by hand.

6.9

Remove tool 02810 and move tool 01765-03 and tighten the seal head to 20 Nm. Use tool 01797-04 and 01765-03.

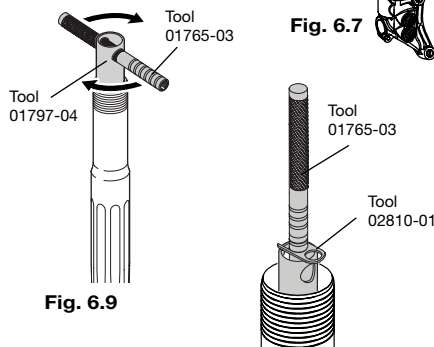

Fig. 6.9

6.10

Once again contract the top out spring using tool 02810-01, tool 01765-03 and tool 01797-04. Check the gas pressure again according to the spec.card.

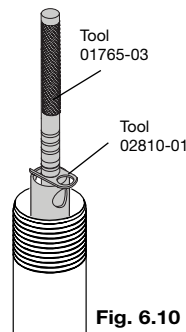

Fig. 6.10

6.11

Tighten the gas filling screw and o-ring with 3Nm.

6.12

Push tool 01765-03 to a stop and adjust the oil level according to chapter **Oil level adjustment**.

NOTE!

Use Öhlins Front fork oil 01309-01 only.

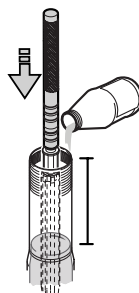

Fig. 6.12

6.13

Reinstall the preload tube, spring and spring support.

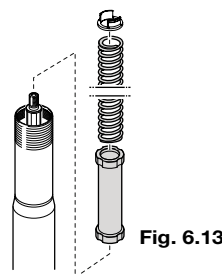

Fig. 6.13

6.14

Reinstall the top cap assembly to the shaft. Tightening torque 20 Nm.

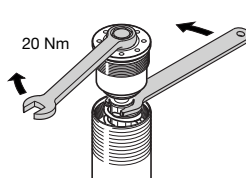

Fig. 6.14

6.15

Reinstall the top cap into the outer fork leg. Use tool 00797-01. Tightening torque 10 Nm. Adjust the preload, compression and rebound.

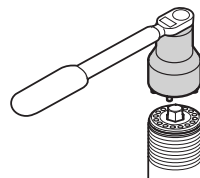

Fig. 6.15

Release the gas pressure from the reservoir according to chapter Disassemble the front fork. Then, continue below.

7.1

Put the fork leg in horizontal position, in a vice with soft jaws.

NOTE!

Do not mix up the two valves, they must be installed in their intended valve housing. We recommend you to remove one valve at a time to keep them apart.

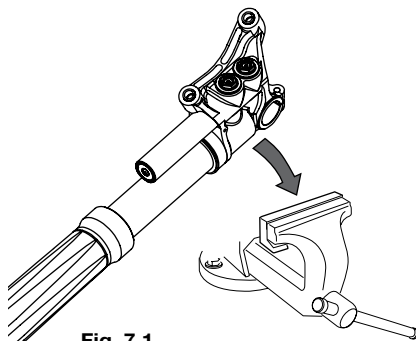

Fig. 7.1

7.2

Remove one valve. Use a 17 mm wrench. Make the necessary changes.

7.3

Add some Öhlins front fork oil 01309 into the valve housing. Reinstall the valve. Make the necessary changes on the other valve in same order.

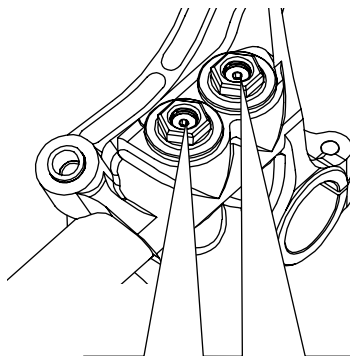
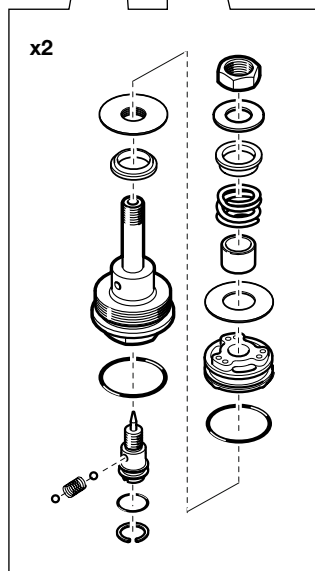

Fig. 7.2

7.4

Add gas pressure to the reservoir according to chapter **Assemble the front fork**.



Oil level adjustments

Compared with conventional type of front forks, the upside down front forks are very sensitive to variations in oil level. Therefore, adjust the oil level with special care. A change in the fork oil level will not affect the spring force at the beginning of the fork travel, but will have a great effect at the end of the travel.

When the oil level is raised:

The air spring in the later half stage of travel is stronger, and make the front fork more progressive.

When the oil level is lowered:

The air spring of the travel is reduced, and thus the front fork less progressive.

NOTE!

Adjust the oil level according to the figure with the fork leg fully compressed (without spring and preload tube). For correct oil level - see specification card.

Air spring characteristics

The air inside of the front fork works as a spring. The graph at the bottom of this page shows the spring force related to stroke when the oil level is changed between 140 mm and 200 mm. Standars oil level is 180 mm.

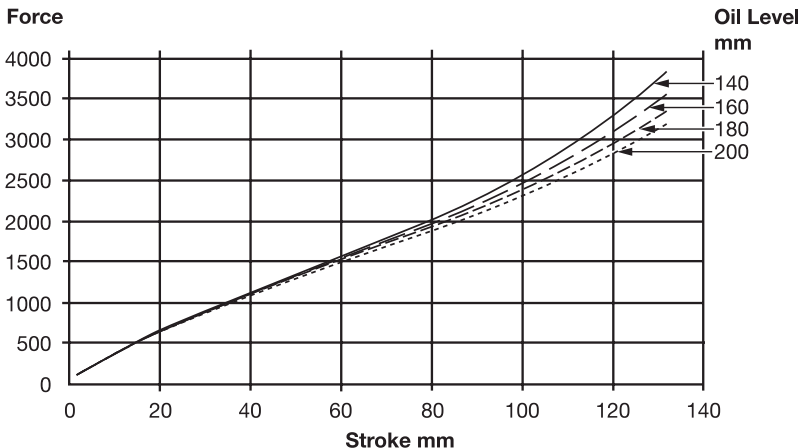
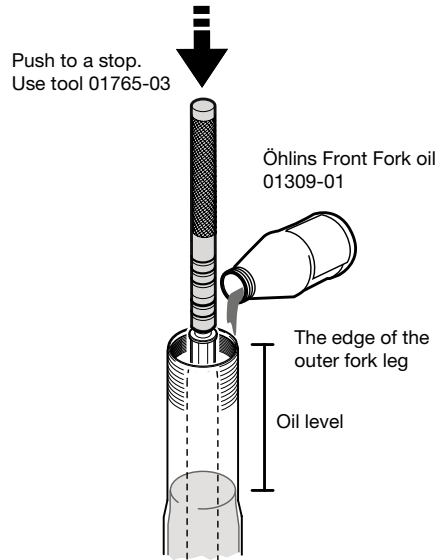

Below you will find a few examples of how to adjust for the most common road holding problems in Road Racing driving.

1

The front wheel “chatters” entering a corner, the problem goes away, as soon as you let the brakes off, or when you get on the power.

- This is caused by the fact that the fork is working too low in the travel and reaches the progressive, hard part at the end of the travel.
- Put on more preload.
- Change to a harder spring.
- If a lot of stroke remains after riding, drop the oil level. See oil level chart.
- Make sure the front fork have no friction.
- Rear ride height is too high, too much rear spring preload.
- Lower the rear end by taking off preload from rear shock spring.

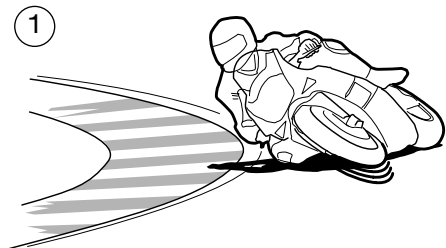

2

The front wheel is jumping during the last part of braking.

- If a lot of stroke remains, the oil level is too high. Lower the oil level.
- If the fork is bottoming, install harder springs and keep the oil level.

3

The front end feels unpredictable and un-safe in the middle of the corner (between braking and getting on power).

- Not enough rebound damping. Add more damping.
- Too much rebound damping. If it at the same time feels harsh, reduce rebound damping.
- Too much compression damping. Also gives a harsh feeling. Reduce compression damping.

4

The front end loses grip coming out of a corner.

- Not enough rebound damping. Add more rebound damping.
- Too much preload. Reduce preload.
- Rear end is too soft. Install harder rear spring.
- Front end is too high. Lower the front end by pulling the fork legs through the triple clamps.

As mentioned in the beginning, the whole bike setup affects the front fork. Try to understand the feelings and work step by step.

NOTE!

We advise to change only one thing at a time and do everything step by step.

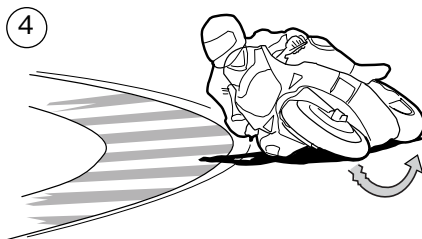

Technical information

Front fork length	740 mm
Stroke	130 mm
Free spring length	260 mm

Recommended settings

Compression	15 clicks
Rebound	12 clicks
Spring preload range	0-18 mm (0-18 turns)

Spring rate

9.5 N/mm (mark -95) STD	04744-95
-------------------------	----------

Optional springs available

8.0 N/mm (mark -80)	04744-80
8.5 N/mm (mark -85)	04744-85
9.0 N/mm (mark -90)	04744-90 (supplied)
10.0 N/mm (mark -10)	04744-10 (supplied)
10.5 N/mm (mark -05)	04744-05
11.0 N/mm (mark -11)	04744-11

Oil capacity

See specification card. Use Öhlins high performance front fork oil R&T 01309 only.

Torque

Lower triple clamp bolt 12-15 Nm
 Upper triple clamp bolt 18-22 Nm

Grease

Öhlins Front Fork Red Grease (RG)	00146-01
Öhlins Front Fork White Grease (WG)	00147-01

Service intervals

This product is designed for racing use only. A frequently service and maintenance is recommended. Recommended service every 10 hours.

Disposal

Discarded products should be handed over to an authorized Öhlins Service Centre for proper disposal.

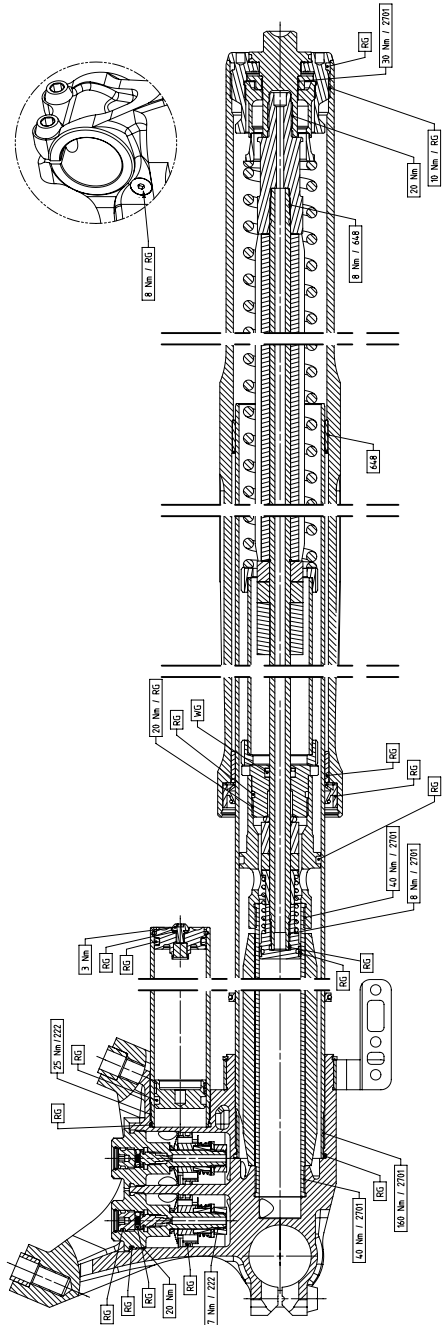

Pos	Part No.	Pcs	Description	Remarks
1-1			Top nut assembly	See page 5
1-2	03316-01	2	Spring support	
1-3	04744-95 04744-10 04744-90	2 2 2	Spring Option spring Option spring	25.5/260/9.5 25.5/260/10.0 25.5/260/9.0
1-4	01438-04	4	Guide ring	
1-5	01460-06	2	Preload tube	157 mm
1-6	01900-06	2	Fork leg outer	
1-7	00191-06	2	Sticker "ÖHLINS"	
1-8	01683-04	2	Bushing, upper	
1-9	01684-04	2	Bushing, lower	
1-10	04758-01	2	Washer	
1-11	04720-02	2	Seal	
1-12	04759-01	2	Circlip	
1-13	01901-04	2	Rod extensioner	
1-14	02302-08	2	Guide sleeve	
1-15	01499-01	2	Circlip	
1-16	01582-17	4	Spacer	10 mm
1-17	01440-01	2	Bump rubber	
1-18	01032-08	2	Back-up ring	
1-19	01027-07	2	X-ring	
1-20	01651-10	2	Seal head	
1-21	00438-02	2	O-ring	
1-22	01056-04	2	Bushing	
1-23	00438-41	2	O-ring	
1-24	01582-15	2	Spacer	15 mm
1-25	01582-16	2	Spacer	8 mm
1-26	01653-07	2	Sleeve	
1-27	01585-01	2	Top-out spring	3,5 N/mm
1-28	02368-02	2	Shaft	502,5 mm
1-29	00338-60	2	O-ring	
1-30	02061-04	2	TTX-piston	
1-31	00338-05	2	O-ring	
1-32	01447-01	2	Piston ring	

Note! The number of pieces is valid for 1 pair of Front fork legs

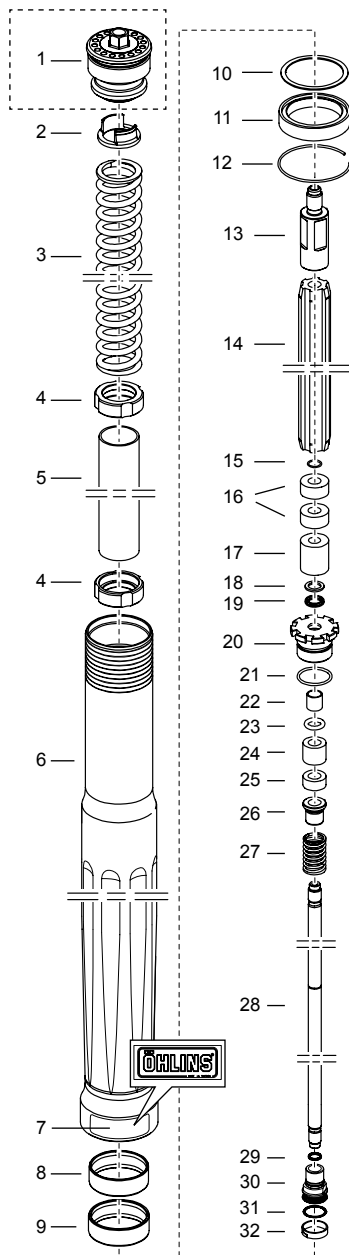

Fig.1

See page 4

Pos	Part No.	Pcs	Description	Remarks
2-1	00638-06	2	O-ring	
2-2	04809-01	2	Cylinder tube extension	
2-3	00338-20	2	O-ring	
2-4	04807-01	2	Volume spacer	
2-5	01486-09	2	Cylinder tube	170 mm
2-6	01703-01	2	Fork leg inner	528 mm
2-7				
2-8	01565-04	1	Stroke indicator	Right leg
2-9	00338-63	2	O-ring	
2-10	04759-02	2	Circlip	
2-11	00382-08	2	Screw	
2-12	01678-14	2	Fender bracket	
2-13	01682-28	2	Fender bracket ring	
2-14	01902-27	1	Fork bottom**	Left leg
	01902-28	1	Fork bottom**	Right leg
2-15	00382-07	2	Screw	
2-16	00438-33	2	O-ring	
2-17	00191-17	2	Sticker "Ö"	
2-18	01240-08	4	Bolt	Titanium
2-19	00161-10	2	Reservoir end assy	
2-20	02806-01	2	Gas piston	
2-21	01447-02	2	Piston ring	
2-22	00338-25	4	O-ring	
2-23	00196-01	2	Sticker "Warning"	
2-24	02812-02	2	Reservoir tube	125 mm
2-25	00338-72	2	O-ring	
2-26	01669-02	4	Caliper sleeve	Standard
	01669-03	4	Caliper sleeve	Optional
2-27	-	2+2	Valve assy	See page 6
2-28	00329-13	2	Circlip	
2-29	00338-59	2	O-ring	
2-30	01050-01	2	Screw	

Note! The number of pieces is valid for 1 pair of Front fork legs.

** 15482-05 spacer must be fitted when 01902-27-28 is used.

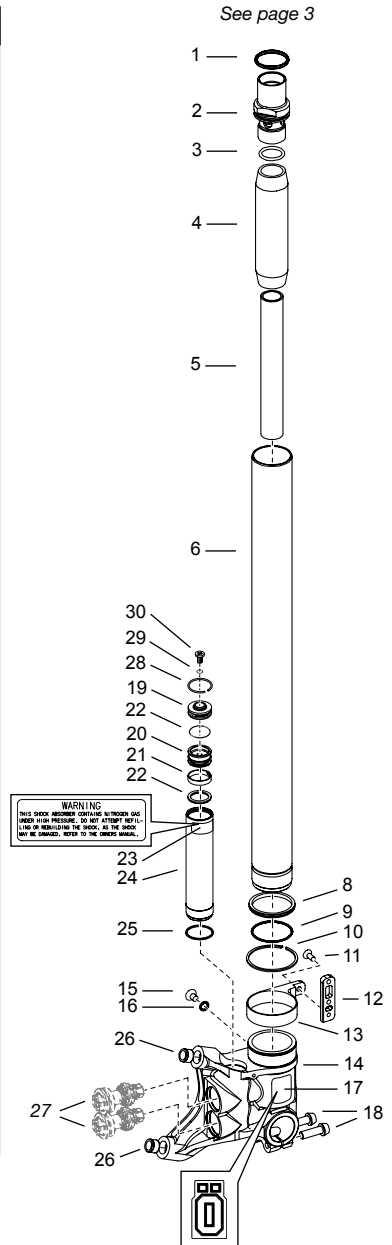

Fig.2

Pos	Part No.	Pcs	Description	Type/Remarks
3-1	03312-02	2	Adjuster	
3-2	03309-01	4	Thin Shim	
3-3	00338-72	2	O-ring	
3-4	03318-05	2	Housing	
3-5	00338-02	2	O-ring	
3-6	03317-01	6	Wave washer	
3-7	03309-02	2	Thick shim	
3-8	03313-01	2	Nut	
3-9	03315-01	2	Preload socket	

Note! The number of pieces is valid for 1 pair of Front fork legs

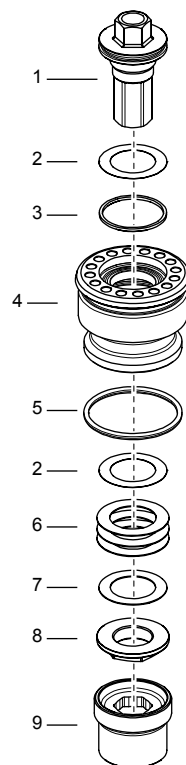

Fig.3

Pos	Part No.	Pcs	Description	Type/Remarks
4-1	01657-01	4	Nut	Aluminium
4-2	00153-01	4	Washer	
4-3	01672-01	4	Spring collar	
4-4	01671-03	4	Spring	8 N/mm
4-5	01669-01	4	Sleeve	
4-6	00530-22	4	Shim	
4-7	02406-01	4	Piston	
4-8	00338-11	4	O-ring	
4-9		-	Shim stack	See spec. card
4-10		-	Clamp washer	See spec. card
4-11	01658-05	4	End piece	
4-12	00438-02	4	O-ring	
4-13	01242-11	4	Adjustment needle	
4-14	00884-02	8	Ball	ø2,5 mm
4-15	01474-01	4	Spring	
4-16	00338-53	4	O-ring	
4-17	01473-02	4	Circlip	

Note! The number of pieces is valid for 1 pair of Front fork legs

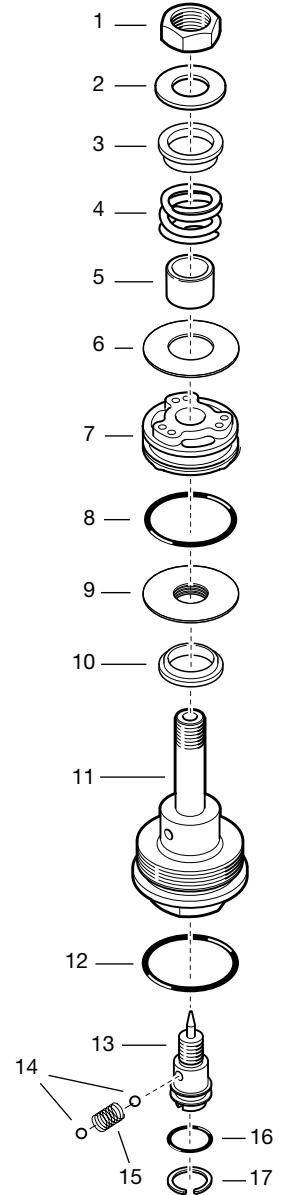

Fig.4

www.öhlins.se

