



# INSTRUCTIONS

-J02502

REV 10-21-2004

Kit Number 44539-02A

## CHROME REAR BRAKE CALIPER KIT

### General

The Chrome Rear Brake Caliper Kit fits the following models:

#### 2000 and later Softail® models

(Except FXSTD and models with Wide Tire Kit Part No. 43685-00 or 44490-00)

#### 2002 - 2004 V-Rod® models

Brake pad, anti-rattle spring, piston and pad pins are not included with this kit. If it is necessary to replace worn or damaged parts, kits which include these parts are available for purchase separately from your Harley Davidson dealer. See the Service Parts illustration.

See the Service Parts illustration for kit contents.

### ⚠ WARNING

The rider's safety depends upon the correct installation of this kit. If the procedure is not within your capabilities or you do not have the correct tools, have a Harley-Davidson dealer perform the installation. Improper installation of this kit could result in death or serious injury. (00308a)

### NOTE

This instruction sheet references Service Manual information. A Service Manual for your model motorcycle is available for purchase at your Harley Davidson dealer.

### Installation

#### Prepare the Motorcycle for Service

1. For all models except V-Rod: Follow the Service Manual instructions to remove the seat.

### ⚠ WARNING

To prevent accidental vehicle start-up, which could cause death or serious injury, disconnect negative (-) battery cable before proceeding. (00048a)

2. For all models except V-Rod: Follow the Service Manual instructions to disconnect the negative (-) battery cable.

**For V-Rod:** Remove the right side cover and remove the maxi-fuse.

Remove the left side cover and disconnect the negative (-) battery cable.

### Remove Rear Brake Caliper

#### Remove the Brake Pads

1. For models equipped with saddlebags: Remove the right-side saddlebag. Refer to the SADDLEBAGS section of the Service Manual.
2. Remove the rear master cylinder reservoir cover.
3. Pry both the inside and outside pads away from the brake disc and toward the caliper assembly to push the caliper pistons back into their bores. Use steady pressure to prevent scoring the brake disc. Pry between the pads and the brake disc.
4. See Figure 1. When the pistons are fully retracted into their bores, pull the pad pins out to allow the pads to drop from the caliper assembly. Note the pads' original orientation for installation.
5. Install the cover on the rear master cylinder reservoir.



Figure 1. Rear Caliper Pad Pins (Softail shown)

#### Remove the Belt Guard and Debris Deflector

Follow the instructions in the Service Manual to remove the belt guard and debris deflector.

#### Remove the Exhaust System

If exhaust system removal is necessary, follow the instructions in the Service Manual to remove the exhaust system.

## Remove the Rear Axle

1. Block the motorcycle under the frame to remove the weight of the motorcycle from the rear wheel.

### CAUTION

Support the rear wheel from underneath during axle removal. Failure to support the rear wheel may cause damage to the motorcycle as the axle is removed.

2. For all models except V-Rod: See Figure 2. Remove the rear axle.
  - a. Loosen the rear axle adjusting nut (2) and retract the axle adjusting screw (1).
  - b. Remove the retaining pin (6), castle nut (5), spacer washer (3), and left rear axle spacer (4) from the left side of the axle.
  - c. Tap the axle toward the right side and remove the axle. The wheel and the wheel spacer will fall loose as the axle is removed.

**For V-Rod:** See Figure 3. Remove the rear axle.

- a. Remove snap ring, axle nut and adjustment eccentric from the right side.
- b. Release belt tension with left side eccentric and tap axle towards left side until axle is free. The wheel and spacer will fall loose as the axle is removed.

### NOTE

Do not operate the rear brake with the rear wheel removed or the caliper pistons may be forced out of the piston bores. Reseating the pistons requires caliper disassembly.

## Remove the Stock Rear Brake Caliper

1. See Figure 4. Apply isopropyl alcohol to the rubber bumper (4) on the brake caliper to ease removal.
2. See Figure 5. Lift the stock rear brake caliper toward the front of the motorcycle. The notch in the caliper must clear the weldment (2) on the swing arm.

### NOTE

Place a container under the brake caliper to catch brake fluid released when removing the brake line from the caliper.

3. See Figure 4. Remove the banjo bolt (2) fastening the rear brake line (3) to the stock rear brake caliper. Save the banjo bolt for brake caliper installation and discard the steel/rubber gaskets (1).

## Inspect Pad and Pins

1. Inspect the brake pads. If brake pad is worn to 1/16 in. (1.6 mm) or less, replace the set. Follow the instructions in the Service Manual.
2. Inspect pad pins for wear and grooving. If wear is more than 0.015 in. (0.38 mm), replace both pins.
3. Inspect the brake disc and, if necessary, follow the instructions in the Service Manual to replace the brake disc.

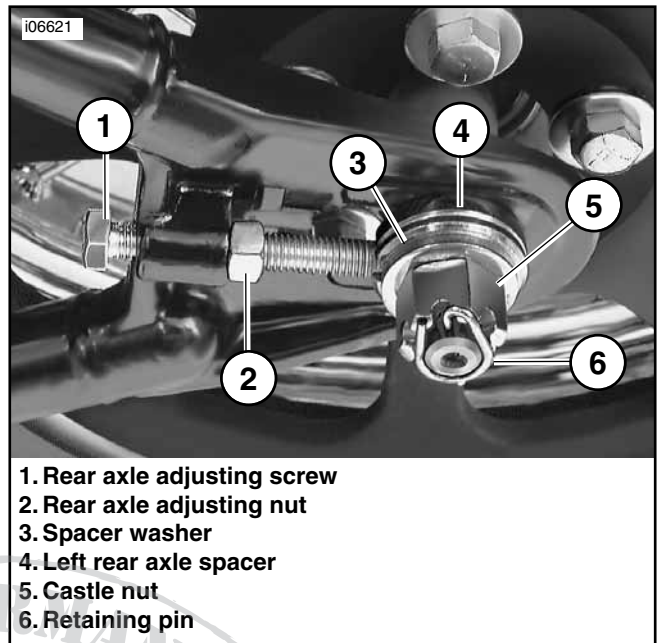

Figure 2. Softtail Rear Axle

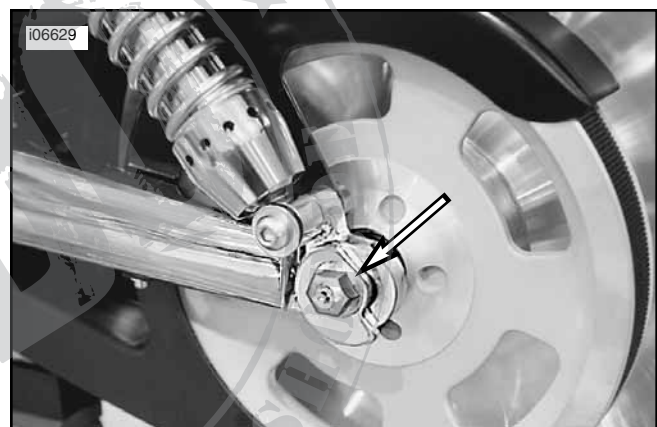

Figure 3. V-Rod Rear Axle  
(left side axle nut welded to eccentric and axle)

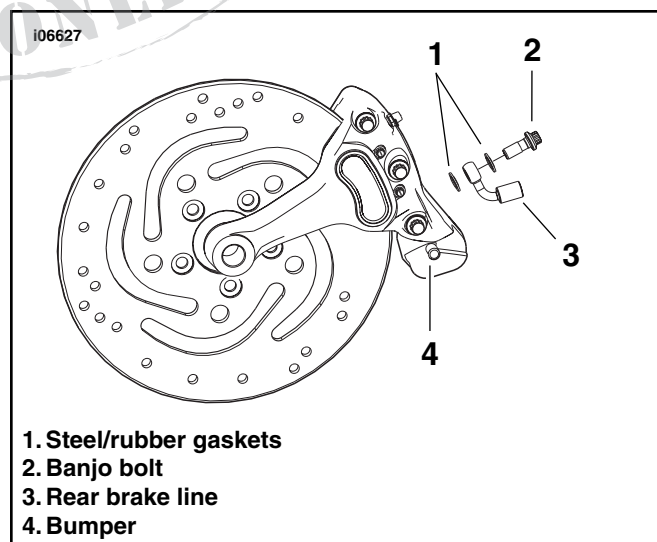

Figure 4. Rear Brake Caliper Removal

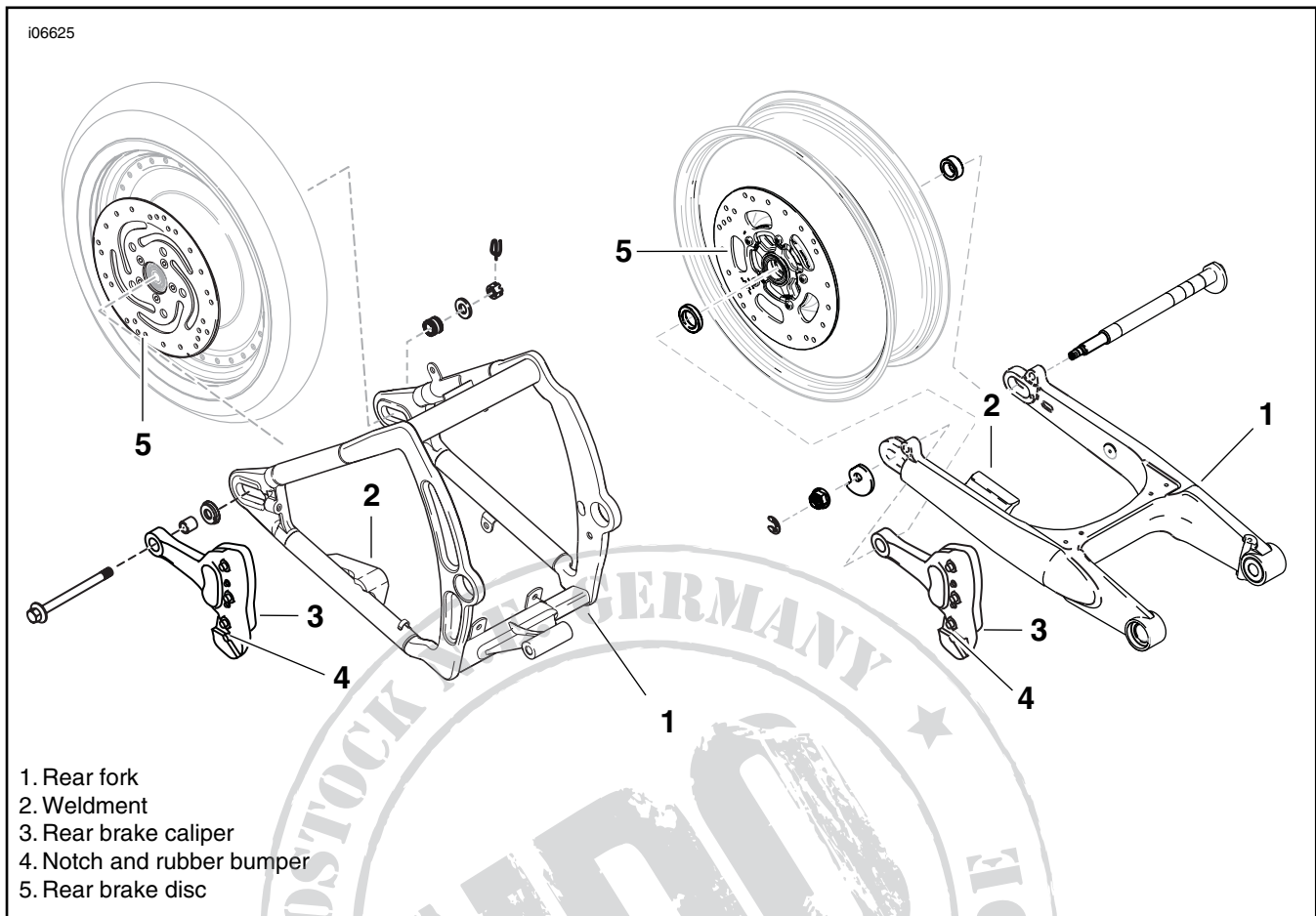

Figure 5. Rear Wheel, Axle, and Caliper Assembly (Softtail left - V-Rod right)

### Install the Chrome Rear Brake Caliper

#### NOTE

Pay close attention to all warnings, cautions, and torque specifications in this instruction sheet and in the service manual when installing this rear brake caliper.

1. See Figure 4. Position the caliper (3) between the brake disc (5) and the rear fork (1). The weldment (2) on the fork should fit between the notch and rubber bumper (4) on the caliper. Verify that the full length of the rubber bumper contacts the underside of the weldment.

#### NOTE

Apply isopropyl alcohol to the rubber bumper for ease of installation.

2. Following the instructions in the Service Manual, install the rear axle and check drive belt tension.

**For all models except V-Rod:** Final tighten axle nut to 60-65 ft-lbs (82-88 Nm).

**For V-Rod:** Final tighten axle nut to 129-142 Nm (95-105 ft-lbs).

#### CAUTION

**Avoid leakage. Be sure gaskets, banjo bolts(s), brake-line and caliper bore are clean and undamaged before assembly. (00032a)**

#### NOTE

To prevent brake fluid loss, do not re-use the steel/rubber gaskets removed with the banjo bolt. Install the brake caliper using the new steel/rubber gaskets provided in this kit.

3. See Figure 3. Lubricate the new steel/rubber gaskets (1) with the grade of brake fluid specified in the Service Manual. Connect the rear brake line (3) to the caliper using banjo bolt (2) and two new gaskets (1). Torque the banjo bolt to 17-22 ft-lbs (23.0-29.8 Nm).
4. If necessary, follow the instructions in the Service Manual and the individual kits to install new brake pads
5. If necessary, follow the instructions in the Service Manual and the individual kits to install new anti-rattle springs and crossover O-rings.
6. If necessary install new pad pins. Listen for the audible click when installing and tighten to 180-200 **in-lbs** (20-23 Nm).

## Bleed the Brakes

### CAUTION

Direct contact of D.O.T. 5 brake fluid with eyes can cause eye irritation, swelling and redness. Avoid eye contact. In case of eye contact flush with large amounts of water and get medical attention. Swallowing large amounts of D.O.T. 5 brake fluid can cause digestive discomfort. If swallowed, obtain medical attention. Use in well ventilated area. KEEP OUT OF THE REACH OF CHILDREN. (00144a)

### NOTE

Hydraulic brake fluid bladder-type pressure equipment can be used to fill the brake master cylinder through the bleeder valve. Remove the master cylinder reservoir cover to prevent the system from pressurizing. Do not use pressure-bleeding equipment when the hydraulic system is sealed with the master cylinder reservoir cover and gasket in place.

1. Remove the cover and gasket from the rear brake master cylinder reservoir.

**For V-Rod:** To locate reservoir, remove right side radiator cover.

### WARNING

Be sure that no lubricant gets on rear tire, wheel or brakes when changing fluid. Traction can be adversely affected which could result in loss of control of the motorcycle and death or serious injury. (00047b)

### CAUTION

D.O.T. 5 silicone hydraulic brake fluid is used in the hydraulic clutch. Do not use other types of fluids as they are not compatible and could cause equipment damage. (00204a)

2. Fill reservoir with the grade of brake fluid specified in the Service Manual.
  - a. **For all models except V-Rod:** See Figure 6. Verify that fluid level is 1/8 in. (3.2 mm) below the gasket surface of the reservoir with the master cylinder in a level position.
  - b. **For V-Rod:** See Figure 7. Verify that the fluid level is 1/2 in. (12.7 mm) below gasket surface of reservoir.

### NOTE

Do not mix D.O.T. 5 silicone hydraulic brake fluid with other grades of fluid as they are not compatible and could cause equipment damage.

3. Remove the bleeder valve cap and attach a tight-fitting flexible hose to the tip of the bleeder valve. Direct the end of the hose into a container.
4. Press the brake pedal to apply hydraulic pressure to the brake system.
5. Open the bleeder valve about 1/2 turn counterclockwise. When the brake pedal has been fully depressed, close the bleeder valve (turn clockwise). Allow the brake pedal to return to its released position.
6. Repeat until all air bubbles are purged from brake line.

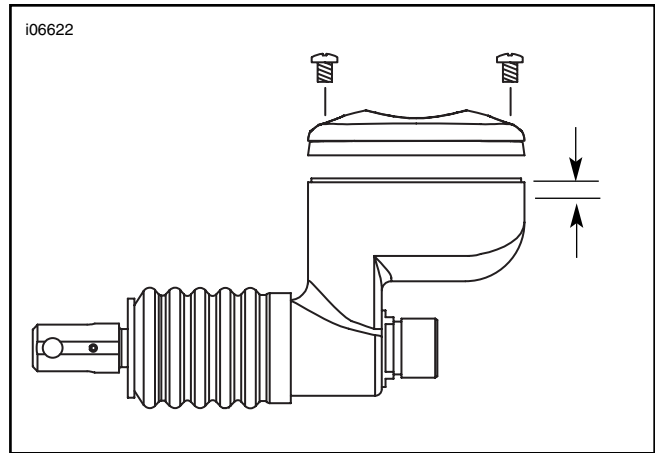

Figure 6. Fill 1/8 in. (3.2 mm) below Reservoir Gasket Surface (Softail)

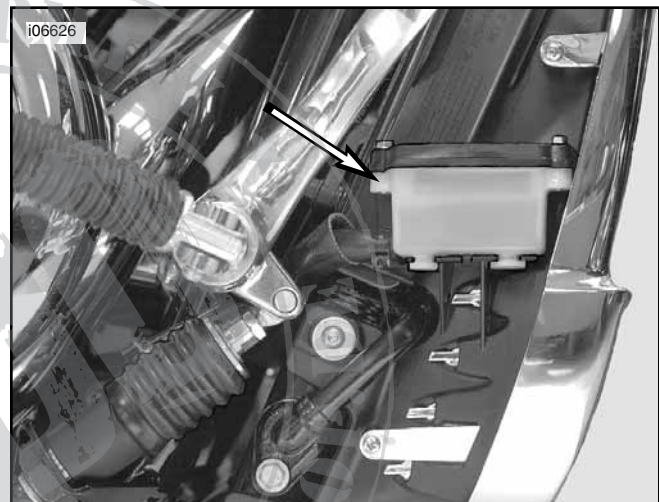

Figure 7. Fill 1/2 in. (12.7 mm) below Reservoir Gasket Surface (V-Rod)



Figure 8. Rear Brake Bleeder Valve

**⚠ WARNING**

Be sure the master cylinder relief port is not plugged. A plugged relief port can cause brake drag or lockup and loss of vehicle control, which could result in death or serious injury. (00317a)

7. To verify proper operation of the master-cylinder relief port, actuate the brake lever with the reservoir cover and gasket removed. A slight spurt of fluid will break the surface if internal components are working properly.
8. Torque the bleeder valve to 80-100 **in-lbs** (9.0-11.3 Nm) and install the bleeder valve cap.
9. Verify master cylinder fluid level.

**For all models except V-Rod:** See Figure 5. Fill reservoir 1/8 in. (3.2 mm) below gasket surface.

**For V-Rod:** See Figure 6. Fill reservoir 1/5 in. (12.7 mm) below gasket surface.

10. Install the gasket and cover on the rear brake master cylinder reservoir.

**For all models except V-Rod:** Tighten cover screws to 6-8 **in-lbs** (0.7-0.9 Nm).

**For V-Rod:** Tighten cover screws to 0.7-0.9 Nm (6-8 **in-lbs**).

11. **For V-Rod only:** Replace the right side radiator cover.

#### Install the Exhaust

If the exhaust system was removed to access the rear axle, refer to the Service Manual for installation.

#### Install the Belt Guard and Debris Deflector

Follow the instructions in the Service Manual to reinstall the belt guard and debris deflector.

#### Return the Motorcycle to Service

1. **For all models except V-Rod:** Connect negative battery cable to battery.

**For V-Rod:** .Connect negative battery cable to battery and install left side cover.

Install maxi-fuse and right side cover.

2. **For all models except V-Rod:** Follow the instructions in the Service Manual to install the seat.

**⚠ WARNING**

After installing seat, pull upward on front of seat to be sure it is in locked position. While riding, a loose seat can shift causing loss of control, which could result in death or serious injury. (00070a)

#### Test the Brakes

**⚠ WARNING**

After servicing brakes and before moving motorcycle, test brakes at low speed. If brakes are not operating properly, testing at high speeds can cause loss of control, which could result in death or serious injury. (00289a)

1. Turn the ignition switch ON.

**⚠ WARNING**

Be sure that all lights and switches operate properly before operating motorcycle. Low visibility of rider can result in death or serious injury. (00316a)

2. Pump the brake lever to verify operation of the stop lamp.
3. Test ride the motorcycle at low speed. If the brake feels spongy, bleed the brake system again.

#### NOTE

Avoid making hard stops for the first 100 miles (160 km). This allows the pads to become conditioned to the brake discs.

4. **For models equipped with saddlebags:** install the right-side saddlebag on models. Refer to the SADDLE-BAGS section of the Service Manual for installation and torque details.



# Service Parts

Part No. 44539-02A

Date 07/04

## Chrome Rear Brake Caliper Kit

106620

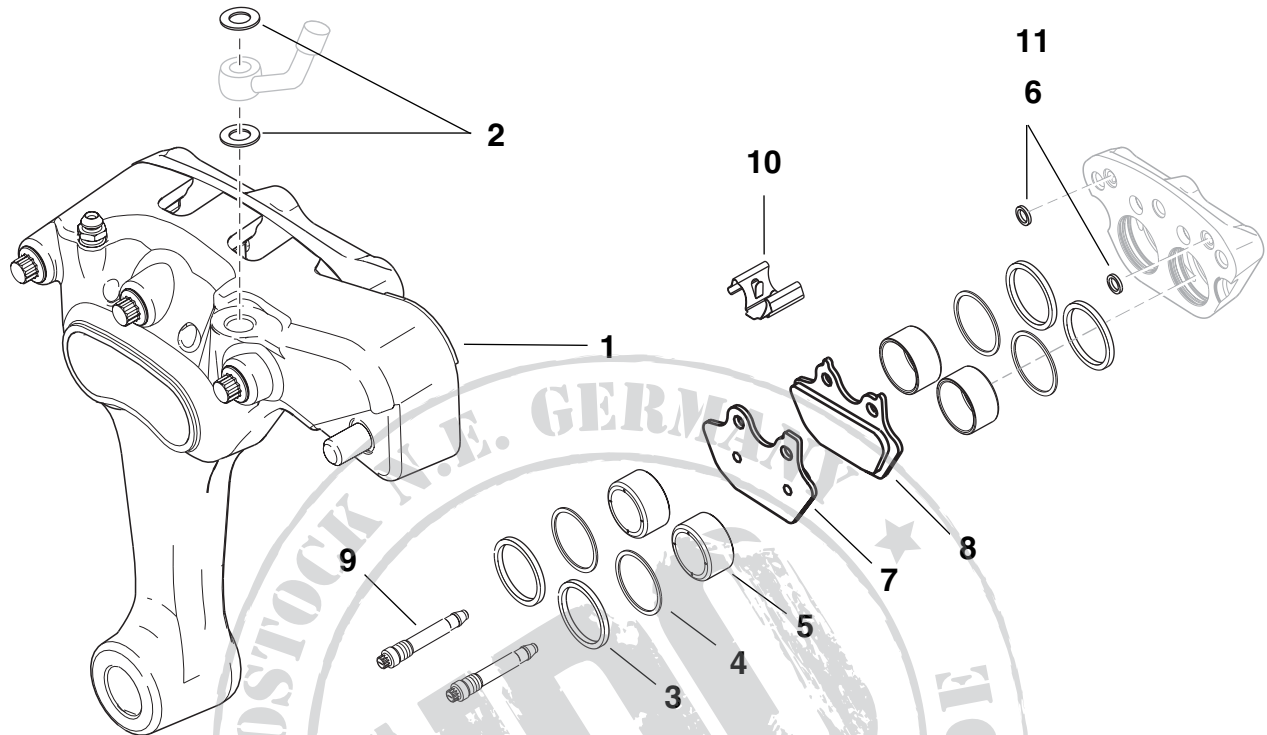

**Item Description (Quantity)**  
**Chrome Rear Brake Caliper Kit**

- 1 Chrome caliper assembly
- 2 Steel/rubber brake line gasket (2)

**Part Number**  
**44539-02A**  
 Not sold separately\*  
 41731-01

**Piston Kit**

- 3 Square seal (4)
- 4 Piston wiper (4)
- 5 Piston (4)
- 6 Crossover O-ring (2)

44313-01\*\*  
 44329-00\*\*  
 44330-00  
 44335-01  
 44336-00\*\*

**Pad Kit**

- 7 Brake pad and holder, inner
- 8 Brake pad and holder, outer

44082-00A  
 Not sold separately  
 Not sold separately

**Pad Pin Kit**

- 9 Pad pin (2)

44314-00 (black) / 44324-02 (silver)  
 Not sold separately

**Anti-Rattle Spring Kit**

- 10 Anti-rattle spring
- 11 Crossover O-ring (2)

44337-00B  
 Not sold separately  
 44336-00\*\*

\* Chrome caliper is an assembly of caliper halves, pistons, seals and wipers, bridge bolts, bleeder valve, rubber bumper, crossover O-rings and anti-rattle spring.

\*\* Piston wipers, seals and crossover O-rings only are available in a separate Seal Kit (Part No. 44315-00).