



# ***Service Manual***

## ***RL4 Vertical Mast***

Part No. 1266665

Rev A

August 2015

---

# Introduction

---

## Important

Read, understand and obey the safety rules and operating instructions in the appropriate Operator's Manual on your machine before attempting any maintenance procedure.

This manual provides detailed scheduled maintenance information for the machine owner and user. It also provides troubleshooting and repair procedures for qualified service professionals.

Basic mechanical, hydraulic and electrical skills are required to perform most procedures. However, several procedures require specialized skills, tools, lifting equipment and a suitable workshop. In these instances, we strongly recommend that maintenance and repair be performed at an authorized Terex dealer service center.

---

## Compliance

### Machine Classification

Group A/Type 1 as defined by ISO 16368

### Machine Design Life

Unrestricted with proper operation, inspection and scheduled maintenance.

---

## Technical Publications

Terex has endeavored to deliver the highest degree of accuracy possible. However, continuous improvement of our products is a Terex policy. Therefore, product specifications are subject to change without notice.

Readers are encouraged to notify Terex of errors and send in suggestions for improvement. All communications will be carefully considered for future printings of this and all other manuals.

---

## Contact Us:

Internet: [www.genielift.com](http://www.genielift.com)

E-mail: [awp.techpub@terex.com](mailto:awp.techpub@terex.com)

---

Copyright © 2015 by Terex Corporation

1266665 Rev A, August 2015

First Edition, First Printing

'Terex' and 'AWP' are registered trademarks of Terex USA, LLC in the U.S.A. and many other countries.

## Serial Number Legend

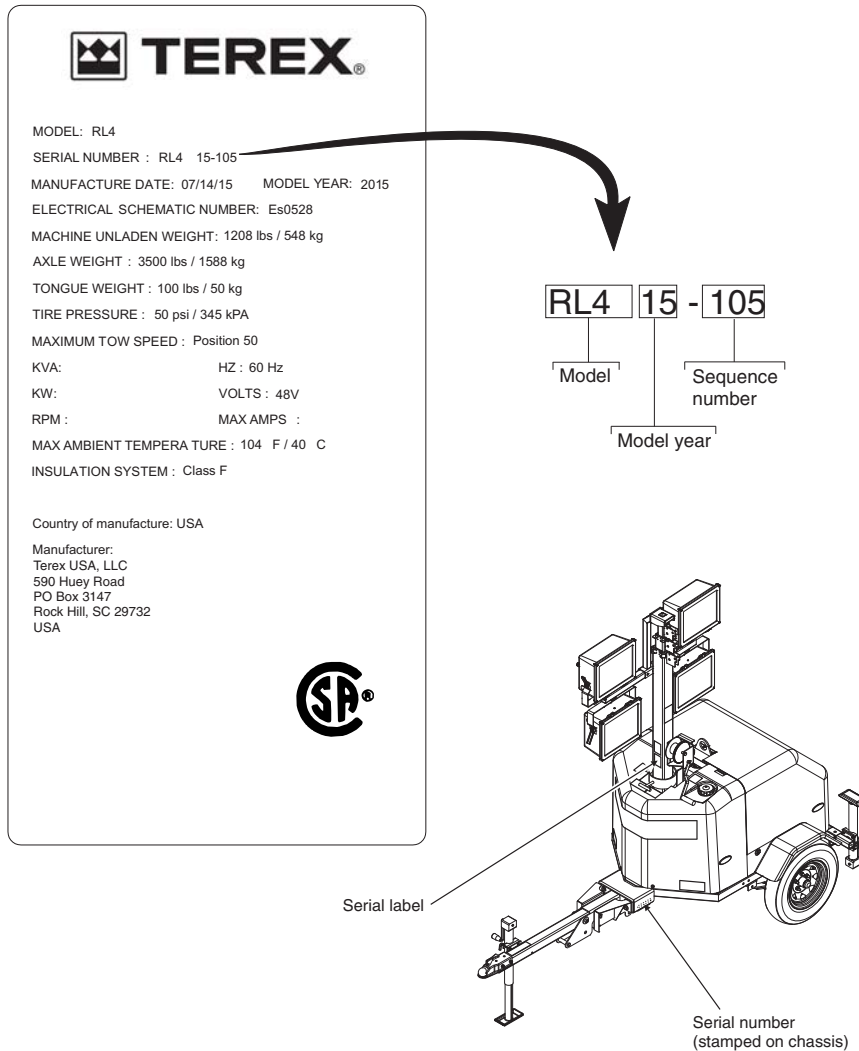

- 1 Model
- 2 Model year
- 3 Sequence number
- 4 Serial label (located on cabinet)
- 5 Serial number (stamped on chassis)

---

## Safety Rules



### Danger

Failure to obey the instructions and safety rules in this manual and the appropriate Operator's Manual on your machine will result in death or serious injury.

Many of the hazards identified in the operator's manual are also safety hazards when maintenance and repair procedures are performed.

### Do Not Perform Maintenance Unless:

- You are trained and qualified to perform maintenance on this machine.
- You read, understand and obey:
  - manufacturer's instructions and safety rules
  - employer's safety rules and worksite regulations
  - applicable governmental regulations
- You have the appropriate tools, lifting equipment and a suitable workshop.

# Safety Rules

## Personal Safety

Any person working on or around a machine must be aware of all known safety hazards. Personal safety and the continued safe operation of the machine should be your top priority.



Read each procedure thoroughly. This manual and the decals on the machine, use signal words to identify the following:



Safety alert symbol—used to alert personnel to potential personal injury hazards. Obey all safety messages that follow this symbol to avoid possible injury or death.



Indicates a imminently hazardous situation which, if not avoided, will result in death or serious injury.



Indicates a potentially hazardous situation which, if not avoided, could result in death or serious injury.



Indicates a potentially hazardous situation which, if not avoided, may cause minor or moderate injury.



Indicates a potentially hazardous situation which, if not avoided, may result in property damage.



Be sure to wear protective eye wear and other protective clothing if the situation warrants it.



Be aware of potential crushing hazards such as moving parts, free swinging or unsecured components when lifting or placing loads. Always wear approved steel-toed shoes.

## Workplace Safety

Any person working on or around a machine must be aware of all known safety hazards. Personal safety and the continued safe operation of the machine should be your top priority.



Be sure to keep sparks, flames and lighted tobacco away from flammable and combustible materials like battery gases and engine fuels. Always have an approved fire extinguisher within easy reach.



Be sure that all tools and working areas are properly maintained and ready for use. Keep work surfaces clean and free of debris that could get into machine components and cause damage.



Be sure any forklift, overhead crane or other lifting or supporting device is fully capable of supporting and stabilizing the weight to be lifted. Use only chains or straps that are in good condition and of ample capacity.



Be sure that fasteners intended for one time use (i.e., cotter pins and self-locking nuts) are not reused. These components may fail if they are used a second time.



Be sure to properly dispose of old oil or other fluids. Use an approved container. Please be environmentally safe.



Be sure that your workshop or work area is properly ventilated and well lit.

---

# Table of Contents

<b>Introduction</b>	<b>Introduction</b> ..... <b>ii</b>
	Important Information ..... ii
	Serial Number Legend ..... iii
	Serial Number Legend ..... iii
<hr/>	
<b>Section 1</b>	<b>Safety Rules</b> ..... <b>iv</b>
	General Safety Rules .....iv
<hr/>	
<b>Section 2</b>	<b>Specifications</b> ..... <b>1</b>
	Machine Specifications ..... 1
	Performance Specifications ..... 1
	Performance Specifications ..... 1
	Machine Specifications ..... 1
	Machine Specifications ..... 2
	Machine Torque Specifications ..... 4
	SAE and Metric Fasteners Torque Charts ..... 5
<hr/>	
<b>Section 3</b>	<b>Scheduled Maintenance Procedures</b> ..... <b>7</b>
	Introduction ..... 7
	Pre-Delivery Preparation Report ..... 10
	Maintenance Inspection Report ..... 11

---

## Table of Contents

<b>Checklist A Procedures</b> .....	<b>13</b>
A-1 Inspect the Manuals and Decals .....	13
A-2 Perform Pre-operation Inspection.....	14
A-3 Perform Function Tests .....	14
A-4 Perform Engine Maintenance .....	15
A-5 Perform Coupler Maintenance.....	15
A-6 Test the Brakes (if equipped).....	16
A-7 Torque the Wheel Lug Nuts.....	16
A-8 Check the Tires and Wheels.....	17
A-9 Inspect the Engine Air Filter.....	17
A-10 Perform Generator Maintenance .....	18
A-11 Perform Engine Maintenance .....	19
A-12 Perform Engine Maintenance .....	19
A-13 Inspect the Cable and Cable Pulleys.....	20
A-14 Perform Engine Maintenance .....	21
A-15 Perform Engine Maintenance .....	21
A-16 Perform Generator Maintenance .....	22
A-17 Drain the Fuel Filter/Water Separator.....	22
A-18 Adjust the Brakes (if equipped) .....	24
<b>Checklist B Procedures</b> .....	<b>25</b>
B-1 Inspect the Engine Start Battery .....	25
B-2 Inspect the Electrical Wiring .....	26
B-3 Torque the Wheel Lug Nuts.....	27
B-4 Perform Engine Maintenance .....	27
B-5 Perform Jack Maintenance .....	28
B-6 Inspect and Lubricate the Winch .....	28
B-7 Lubricate the T-bolt.....	29
B-8 Inspect and Adjust the Brakes (if equipped).....	29
B-9 Inspect the Suspension .....	31
B-10 Perform Engine Maintenance .....	32

# Table of Contents

	<b>Checklist C Procedures.....</b>	<b>33</b>
	C-1 Perform Engine Maintenance.....	33
	C-2 Clean the Light Assemblies.....	34
	C-3 Grease the Wheel Bearings .....	34
	C-4 Inspect the Electric Brake Magnets .....	36
	C-5 Perform Engine Maintenance.....	37
	C-6 Perform Generator Maintenance.....	38
	<b>Checklist D Procedures.....</b>	<b>39</b>
	D-1 Perform Engine Maintenance.....	39
	D-2 Perform Generator Maintenance.....	40
	D-3 Perform Coupler Maintenance .....	40
	<b>Checklist E Procedures.....</b>	<b>41</b>
	E-1 Inspect the Cable and Cable Pulleys .....	41
	E-2 Perform Engine Maintenance.....	42
	E-3 Perform Engine Maintenance.....	43
	E-4 Perform Generator Maintenance.....	43
	E-5 Perform Generator Maintenance.....	44
	E-6 Perform Generator Maintenance.....	44
<b>Section 4</b>	<b>Repair Procedures .....</b>	<b>45</b>
	Introduction .....	45
	<b>Lighting .....</b>	<b>47</b>
	1-1 How to Remove a Lamp .....	47
	1-2 How to Check Line Voltage .....	47
	1-3 How to Check the Open Circuit Voltage .....	48



# Table of Contents

<b>Mast</b> .....	<b>49</b>
2-1 How to Remove the Mast Assembly .....	49
2-2 How to Disassemble the Mast Assembly .....	49
2-3 How to Replace the Mast Lift Cables .....	51
2-4 How to Remove the Manual Winch .....	52
2-5 How to Remove the Electric Winch .....	53
<b>Kohler KDW1003 Engine</b> .....	<b>54</b>
3-1 Timing Adjustment-Kohler Engines .....	54
3-2 Glow Plugs-Kohler Engines .....	54
3-3 Coolant Temperature and Oil Pressure Switches-Kohler Engines .....	54
<b>Kubota D1105-E Engine</b> .....	<b>55</b>
4-1 Timing Adjustment-Kubota Engines .....	55
4-2 Glow Plugs-Kubota Engines .....	55
4-3 Coolant Temperature and Oil Pressure Switches-Kubota Engines .....	55
<b>Generator</b> .....	<b>56</b>
5-1 Generator .....	56
5-2 How to Check a Generator Capacitor .....	57
5-3 How to Check a Generator Diode .....	57
<b>Light Ballast</b> .....	<b>59</b>
6-1 Ground Controls .....	59
6-2 Light Ballast .....	60
<b>Fuel Tank</b> .....	<b>61</b>
7-1 Fuel Tank .....	61

# Table of Contents

<b>Section 5</b>	<b>Diagnostics</b> .....	<b>62</b>
	Introduction .....	62
<b>Section 6</b>	<b>Schematics</b> .....	<b>68</b>
	Introduction .....	68
	Wire Color Legend .....	69
	RL4 Control Box AC Voltage Wiring - Standard .....	71
	RL4 Control Box AC Voltage Wiring - Standard .....	72
	RL4 Control Box AC Voltage Wiring - Autostart .....	73
	RL4 Control Box AC Voltage Wiring - Autostart .....	74
	RL4 DC Control Box - Standard.....	75
	RL4 DC Control Box - Standard.....	76
	RL4 DC Engine Components - DynaGen Autostart.....	77
	RL4 DC Engine Components - DynaGen Autostart.....	78
	RL4 DC Engine Components - Kohler .....	79
	RL4 DC Engine Components - Kohler .....	80
	RL4 DC Engine Components - Kubota .....	81
	RL4 DC Engine Components - Kubota .....	82
	RL4 DC Control Box - Timed Oil Switch .....	83
	RL4 DC Control Box - Timed Oil Switch .....	84
	RL4 DC Control Box - Low Fuel Shut Down.....	85
	RL4 DC Control Box - Low Fuel Shut Down.....	86
	RL4 Running Lights - Front Fairing Section.....	87
	RL4 Running Lights - Front Fairing Section.....	88
	RL4 Running Lights - Rear Fairing Section .....	89
	RL4 Running Lights - Rear Fairing Section .....	90
	RL4 Electrical Winch Option .....	91
	RL4 Electrical Winch Option .....	92

# Specifications

## Machine Specifications

<b>Total lighting wattage</b>	4 x 1000 watts
<b>Fuel capacities</b>	
Single tank	45 gallons 170 liters
<b>Tires and wheels</b>	
Tire size	ST175/80D13
Load range	C
Lug nut torque, dry	90 ft-lbs 122 Nm
Lug nut torque, lubricated	67.5 ft-lbs 91.5 Nm

## Performance Specifications

<b>Tongue weight, maximum</b>	
With fuel (45 gallon tank)	203 lbs 92 kg
<b>Run time</b>	
45 gallon tank	110 hours

**For operational specifications, refer to the Operator's Manual.**

**Continuous improvement of our products is a Genie policy. Product specifications are subject to change without notice or obligation.**

## Generator Options

<b>Coliseum 6 kW 1CBC06-TX</b>	
Generator rpm @ full load	60Hz, 1800 rpm
Temperature, ambient maximum	104° F 40° C
Power	6 kW
<b>Coliseum 7 kW 1CBC07-TX</b>	
Generator rpm @ full load	60 Hz, 1800 rpm
Temperature, ambient maximum	104° F 40° C
Power	7 kW
<b>Coliseum 8 kW 1CBC08-TX</b>	
Generator rpm @ full load	60 Hz, 1800 rpm
Temperature, ambient maximum	104° F 40° C
Power	8 kW

**For operational specifications, refer to the Operator's Manual.**

**Continuous improvement of our products is a Genie policy. Product specifications are subject to change without notice or obligation.**

## Specifications

### Kohler KDW1003 Engine

<b>Displacement</b>	62.7 cu in 1.3 liters
<b>Number of cylinders</b>	3
<b>Bore and Stroke</b>	2.95 x 3.1 inches 75 x 77.6 mm
<b>Horsepower</b>	26.1 @ 3600 19.5 kW
<b>Firing order</b>	1 - 2 - 3
<b>Compression ratio</b>	22.8:1
<b>Compression pressure</b>	412 to 469 psi 28.4 to 32.3 bar
<b>Engine speed</b>	3600 rpm
<b>Governor</b>	centrifugal mechanical
<b>Valve Clearance, cold</b>	0.0057 to 0.0072 in 0.145 to 0.185 mm
<b>Engine coolant</b>	
Capacity	1.37 quarts 1.3 liters
<b>Lubrication system</b>	
Oil pressure	28 to 64 psi 1.93 to 4.41 bar
Oil capacity (including filter)	2.54 quarts 2.4 liters

Oil pressure switch (engine shutoff pressure)	7 psi
---	-------

#### Oil viscosity requirements

Unit ships with 10W-30. Extreme operating temperatures may require the use of alternative engine oils. For oil requirements, refer to the Engine Operator Manual for your engine.

#### Injection system

Injection pump	Bosch MD mini
Injection timing	19° BTDC
Injection pump pressure, maximum	1991 psi 137 bar

#### Fuel requirement

For fuel requirements, refer to the engine Operator Manual for your engine.

#### Battery

Type	12V DC
Group	27TM
Quantity	1
Cold cranking ampere	500
Reserve capacity @ 75A rate	105 minutes

#### Alternator

Alternator output	40A, 12V DC
Fan belt deflection	1/4 to 3/8 inch 7 to 9 mm

# Specifications

## Kubota D1105-E Engine

<b>Displacement</b>	68.53 cu in 1.12 liters
<b>Number of cylinders</b>	3
<b>Bore and Stroke</b>	3.07 x 3.09 inches 78 x 78.4 mm
<b>Horsepower</b>	13.6 @ 1800 10.1 kW
<b>Firing order</b>	1 - 2 - 3
<b>Compression ratio</b>	23:1
<b>Compression pressure</b>	412 to 469 psi 28.4 to 32.3 bar
<b>Engine speed</b>	1800 rpm
<b>Governor</b>	centrifugal mechanical
<b>Valve Clearance, cold</b>	0.0057 to 0.0072 in 0.145 to 0.185 mm
<b>Engine coolant</b>	
Capacity	3.27 quarts 3.1 liters
<b>Lubrication system</b>	
Oil pressure	28 to 64 psi 1.93 to 4.41 bar
Oil capacity (including filter)	5.4 quarts 5.1 liters

Oil pressure switch (engine shutoff pressure)	7 psi
---	-------

### Oil viscosity requirements

Unit ships with 10W-30. Extreme operating temperatures may require the use of alternative engine oils. For oil requirements, refer to the Engine Operator Manual for your engine.

### Injection system

Injection pump	Bosch MD mini
Injection timing	19° BTDC
Injection pump pressure, maximum	1991 psi 137 bar

### Fuel requirement

For fuel requirements, refer to the engine Operator Manual for your engine.

### Battery

Type	12V DC
Group	27TM
Quantity	1
Cold cranking ampere	500
Reserve capacity @ 75A rate	105 minutes

### Alternator

Alternator output	40A, 12V DC
Fan belt deflection	1/4 to 3/8 inch 7 to 9 mm

# Specifications

## Machine Torque Specifications

### Generator

Flex plate to flywheel	15 ft-lbs 20 Nm
Generator case to bell housing	30 ft-lbs 41 Nm
Generator isolators	75 ft-lbs 102 Nm

### Wheel lugs



Lug nut torque, lubricated	67.5 ft-lbs 91.5 Nm
Lug nut torque, dry	90 ft-lbs 122 Nm





### Engine vibration isolators

Mounting bolts, dry	60 ft-lbs 81 Nm
Mounting bolts, lubricated	45 ft-lbs 61 Nm

**Continuous improvement of our products is a Genie policy. Product specifications are subject to change without notice or obligation.**

# Specifications

<b>SAE FASTENER TORQUE CHART</b>											
• This chart is to be used as a guide only unless noted elsewhere in this manual •											
SIZE	THREAD	Grade 5 				Grade 8 				A574 High Strength Black Oxide Bolts	
		LUBED		DRY		LUBED		DRY		LUBED	
		in-lbs	Nm	in-lbs	Nm	in-lbs	Nm	in-lbs	Nm	in-lbs	Nm
1/4	20	80	9	100	11.3	110	12.4	140	15.8	130	14.7
	28	90	10.1	120	13.5	120	13.5	160	18	140	15.8
		LUBED		DRY		LUBED		DRY		LUBED	
		ft-lbs	Nm	ft-lbs	Nm	ft-lbs	Nm	ft-lbs	Nm	ft-lbs	Nm
5/16	18	13	17.6	17	23	18	24	25	33.9	21	28.4
	24	14	19	19	25.7	20	27.1	27	36.6	24	32.5
3/8	16	23	31.2	31	42	33	44.7	44	59.6	38	51.5
	24	26	35.2	35	47.4	37	50.1	49	66.4	43	58.3
7/16	14	37	50.1	49	66.4	50	67.8	70	94.7	61	82.7
	20	41	55.5	55	74.5	60	81.3	80	108.4	68	92.1
1/2	13	57	77.3	75	101.6	80	108.4	110	149	93	126
	20	64	86.7	85	115	90	122	120	162	105	142
9/16	12	80	108.4	110	149	120	162	150	203	130	176
	18	90	122	120	162	130	176	170	230	140	189
5/8	11	110	149	150	203	160	217	210	284	180	244
	18	130	176	170	230	180	244	240	325	200	271
3/4	10	200	271	270	366	280	379	380	515	320	433
	16	220	298	300	406	310	420	420	569	350	474
7/8	9	320	433	430	583	450	610	610	827	510	691
	14	350	474	470	637	500	678	670	908	560	759
1	8	480	650	640	867	680	922	910	1233	770	1044
	12	530	718	710	962	750	1016	990	1342	840	1139
1 1/8	7	590	800	790	1071	970	1315	1290	1749	1090	1477
	12	670	908	890	1206	1080	1464	1440	1952	1220	1654
1 1/4	7	840	1138	1120	1518	1360	1844	1820	2467	1530	2074
	12	930	1260	1240	1681	1510	2047	2010	2725	1700	2304
1 1/2	6	1460	1979	1950	2643	2370	3213	3160	4284	2670	3620
	12	1640	2223	2190	2969	2670	3620	3560	4826	3000	4067

<b>METRIC FASTENER TORQUE CHART</b>																
• This chart is to be used as a guide only unless noted elsewhere in this manual •																
Size (mm)	Class 4.6 				Class 8.8 				Class 10.9 				Class 12.9 			
	LUBED		DRY		LUBED		DRY		LUBED		DRY		LUBED		DRY	
	in-lbs	Nm	in-lbs	Nm	in-lbs	Nm	in-lbs	Nm	in-lbs	Nm	in-lbs	Nm	in-lbs	Nm	in-lbs	Nm
5	16	1.8	21	2.4	41	4.63	54	6.18	58	6.63	78	8.84	68	7.75	91	10.3
6	19	3.05	36	4.07	69	7.87	93	10.5	100	11.3	132	15	116	13.2	155	17.6
7	45	5.12	60	6.83	116	13.2	155	17.6	167	18.9	223	25.2	1.95	22.1	260	29.4
	LUBED		DRY		LUBED		DRY		LUBED		DRY		LUBED		DRY	
	ft-lbs	Nm	ft-lbs	Nm	ft-lbs	Nm	ft-lbs	Nm	ft-lbs	Nm	ft-lbs	Nm	ft-lbs	Nm	ft-lbs	Nm
8	5.4	7.41	7.2	9.88	14	19.1	18.8	25.5	20.1	27.3	26.9	36.5	23.6	32	31.4	42.6
10	10.8	14.7	14.4	19.6	27.9	37.8	37.2	50.5	39.9	54.1	53.2	72.2	46.7	63.3	62.3	84.4
12	18.9	25.6	25.1	34.1	48.6	66	64.9	88	69.7	94.5	92.2	125	81	110	108	147
14	30.1	40.8	40	54.3	77.4	105	103	140	110	150	147	200	129	175	172	234
16	46.9	63.6	62.5	84.8	125	170	166	226	173	235	230	313	202	274	269	365
18	64.5	87.5	86.2	117	171	233	229	311	238	323	317	430	278	377	371	503
20	91	124	121	165	243	330	325	441	337	458	450	610	394	535	525	713
22	124	169	166	225	331	450	442	600	458	622	612	830	536	727	715	970
24	157	214	210	285	420	570	562	762	583	791	778	1055	682	925	909	1233



---

# Specifications

This page intentionally left blank.



## Scheduled Maintenance Procedures



### Observe and Obey:

- ☑ Maintenance inspections shall be completed by a person trained and qualified on the maintenance of this machine.
- ☑ Scheduled maintenance inspections shall be completed daily, quarterly, semi-annually, annually and every 2 years as specified of the *Maintenance inspection Report*. The frequency and extent of periodic examinations and tests may also depend on national regulations.

**⚠ WARNING** Failure to perform each procedure as presented and scheduled may cause death, serious injury or substantial damage.

- ☑ Immediately tag and remove from service a damaged or malfunctioning machine.
- ☑ Repair any machine damage or malfunction before operating the machine.
- ☑ Use only Terex approved replacement parts.
- ☑ Machines that have been out of service for a period longer than 3 months must complete the quarterly inspection.

### Machine Configuration:

- ☑ Unless otherwise specified, perform each procedure with the machine in the following configuration:
  - Machine parked on a firm, level surface
  - Mast in the stowed position
  - Key switch in the off position with the key removed
  - The red Emergency Stop button in the off position on the electrical control box
  - Wheels chocked
  - Light switches in the off position
  - All external AC power supply disconnected from the machine
  - Boom in the stowed position
  - Turntable secured with the turntable rotation lock

---

# Scheduled Maintenance Procedures

## About This Section

This section contains detailed procedures for each scheduled maintenance inspection.

Each procedure includes a description, safety warnings and step-by-step instructions.

## Symbols Legend



Safety alert symbol—used to alert personnel to potential personal injury hazards. Obey all safety messages that follow this symbol to avoid possible injury or death.



Indicates a imminently hazardous situation which, if not avoided, will result in death or serious injury.



Indicates a potentially hazardous situation which, if not avoided, could result in death or serious injury.



Indicates a potentially hazardous situation which, if not avoided, may cause minor or moderate injury.



Indicates a potentially hazardous situation which, if not avoided, may result in property damage.

- ⊙ Indicates that a specific result is expected after performing a series of steps.
- ⊗ Indicates that an incorrect result has occurred after performing a series of steps.

# Scheduled Maintenance Procedures

## Maintenance Symbols Legend

Note: The following symbols have been used in this manual to help communicate the intent of the instructions. When one or more of the symbols appear at the beginning of a maintenance procedure, it conveys the meaning below.



Indicates that tools will be required to perform this procedure.



Indicates that new parts will be required to perform this procedure.



Indicates that dealer service will be required to perform this procedure.



Indicates that a cold engine will be required to perform this procedure.



Indicates that a warm engine will be required to perform this procedure.

## Pre-delivery Preparation Report

The pre-delivery preparation report contains checklists for each type of scheduled inspection.

Make copies for each inspection. Store completed forms as required.

## Maintenance Schedule

The *Scheduled Maintenance Procedures* section and the *Maintenance Inspection Report* have been divided into subsections. Use the following chart to determine which group(s) of procedures are required to perform a scheduled inspection.

Inspection	Checklist
Daily or every 8 hours	A
Quarterly or every 250 hours	A + B
Semi-annually or every 500 hours	A + B + C
Annually or every 1000 hours	A + B + C + D
Two-year or every 2000 hours	A + B + C + D + E

## Maintenance Inspection Report

The maintenance inspection report contains checklists for each type of scheduled inspection.

Make copies of the *Maintenance Inspection Report* to use for each inspection. Maintain completed forms for a minimum of 4 years or in compliance with your employer, jobsite and governmental regulations and requirements.

# Pre-Delivery Preparation Report

## Fundamentals

It is the responsibility of the dealer to perform the Pre-delivery Preparation.

The Pre-delivery Preparation is performed prior to each delivery. The inspection is designed to discover if anything is apparently wrong with a machine before it is put into service.

A damaged or modified machine must never be used. If damage or any variation from factory delivered condition is discovered, the machine must be tagged and removed from service.

Repairs to the machine may only be made by a qualified service technician, according to the manufacturer's specifications.

Scheduled maintenance inspections shall be performed by qualified service technicians, according to the manufacturer's specifications and the requirements listed in the responsibilities manual.

## Instructions

Use the operator's manual on your machine.

The Pre-delivery Preparation consists of completing the Pre-operation Inspection, the Maintenance items and the Function Tests.

Use this form to record the results. Place a check in the appropriate box after each part is completed. Follow the instructions in the operator's manual.

If any inspection receives an N, remove the machine from service, repair and re-inspect it. After repair, place a check in the R box.

### Legend

- Y = yes, acceptable
- N = no, remove from service
- R = repaired

### Comments

Pre-delivery Preparation	Y	N	R
Pre-operation inspection completed			
Maintenance items completed			
Function tests completed			

\_\_\_\_\_

**Model**

\_\_\_\_\_

**Serial number**

\_\_\_\_\_

**Date**

\_\_\_\_\_

**Machine owner**

\_\_\_\_\_

**Inspected by (print)**

\_\_\_\_\_

**Inspector signature**

\_\_\_\_\_

**Inspector title**

\_\_\_\_\_

**Inspector company**



Terex South Dakota, Inc USA  
 500 Oak Wood Road  
 PO Box 1150  
 Watertown, SD 57201-6150  
 (605) 882-4000

Genie UK  
 The Maltings, Wharf Road  
 Grantham, Lincolnshire  
 NG31- 6BH England  
 (44) 1476-584333

# Maintenance Inspection Report

**Model**  

---

**Serial number**  

---

**Date**  

---

**Hour meter**  

---

**Machine owner**  

---

**Inspected by (print)**  

---

**Inspector signature**  

---

**Inspector title**  

---

**Inspector company**  

---

## Instructions

- Make copies of this report to use for each inspection.
- Select the appropriate checklist(s) for the type of inspection(s) to perform.

<input type="checkbox"/>	Daily or every 8 hours	A
<input type="checkbox"/>	Quarterly or every 250 hours	A + B
<input type="checkbox"/>	Semi-annually or every 500 hours	A + B + C
<input type="checkbox"/>	Annually or every 1000 hours	A + B + C + D
<input type="checkbox"/>	Two-year or every 2000 hours	A + B + C + D + E

- Place a check in the appropriate box after each inspection procedure is completed.
- Use the step-by-step procedures in this section to learn how to perform these inspections.
- If any inspection receives an "N," tag and remove the machine from service, repair and re-inspect it. After repair, place a check in the "R" box.

## Legend

- Y = yes, acceptable
- N = no, remove from service
- R = repaired

Checklist A		Y	N	R
A-1	Inspect the manuals and decals			
A-2	Pre-operation inspection			
A-3	Function tests			
<b>Perform after 8 hours:</b>				
A-4	Engine maintenance			
<b>Perform before towing:</b>				
A-5	Coupler			
A-6	Brakes (if equipped)			
<b>Perform after 10 miles:</b>				
A-7	Lug nuts			
<b>Perform weekly:</b>				
A-8	Tires and wheels			
A-9	Engine air filter			
A-10	Generator maintenance			
A-11	Engine maintenance			
<b>Perform after 50 hours:</b>				
A-12	Engine maintenance			
<b>Perform monthly:</b>				
A-13	Cables and pulleys			
<b>Perform every 100 hours:</b>				
A-14	Engine maintenance			
<b>Perform every 200 hours:</b>				
A-15	Engine maintenance			
A-16	Generator maintenance			
A-17	Fuel/Water separator			
A-18	Brakes (if equipped)			

Checklist B		Y	N	R
B-1	Batteries			
B-2	Electrical wiring			
B-3	Lug nuts			
B-4	Engine maintenance			
B-5	Jack			
B-6	Winch			
B-7	T-bolt			
<b>Perform every 3000 miles:</b>				
B-8	Brakes (if equipped)			
B-9	Suspension			
<b>Perform every 400 hours:</b>				
B-10	Engine maintenance			

## Comments

---

# Maintenance Inspection Report

Model \_\_\_\_\_

Serial number \_\_\_\_\_

Date \_\_\_\_\_

Hour meter \_\_\_\_\_

Machine owner \_\_\_\_\_

Inspected by (print) \_\_\_\_\_

Inspector signature \_\_\_\_\_

Inspector title \_\_\_\_\_

Inspector company \_\_\_\_\_

## Instructions

- Make copies of this report to use for each inspection.
- Select the appropriate checklist(s) for the type of inspection(s) to perform.

<input type="checkbox"/>	Daily or every 8 hours	A
<input type="checkbox"/>	Quarterly or every 250 hours	A + B
<input type="checkbox"/>	Semi-annually or every 500 hours	A + B + C
<input type="checkbox"/>	Annually or every 1000 hours	A + B + C + D
<input type="checkbox"/>	Two-year or every 2000 hours	A + B + C + D + E

- Place a check in the appropriate box after each inspection procedure is completed.
- Use the step-by-step procedures in this section to learn how to perform these inspections.
- If any inspection receives an "N," tag and remove the machine from service, repair and re-inspect it. After repair, place a check in the "R" box.

## Legend

Y = yes, acceptable  
 N = no, remove from service  
 R = repaired

Checklist C		Y	N	R
C-1	Engine maintenance	<input type="checkbox"/>	<input type="checkbox"/>	<input type="checkbox"/>
C-2	Lights	<input type="checkbox"/>	<input type="checkbox"/>	<input type="checkbox"/>
<b>Perform every 6000 miles:</b>				
C-3	Wheel bearings	<input type="checkbox"/>	<input type="checkbox"/>	<input type="checkbox"/>
C-4	Brakes (if equipped)	<input type="checkbox"/>	<input type="checkbox"/>	<input type="checkbox"/>
<b>Perform every 800 hours:</b>				
C-5	Engine maintenance	<input type="checkbox"/>	<input type="checkbox"/>	<input type="checkbox"/>
<b>Perform every 2000 hours:</b>				
C-6	Generator maintenance	<input type="checkbox"/>	<input type="checkbox"/>	<input type="checkbox"/>
Checklist D		Y	N	R
<b>Perform every 1500 hours:</b>				
D-1	Engine maintenance	<input type="checkbox"/>	<input type="checkbox"/>	<input type="checkbox"/>
<b>Perform every 8000 hours:</b>				
D-2	Generator maintenance	<input type="checkbox"/>	<input type="checkbox"/>	<input type="checkbox"/>
<b>Perform annually:</b>				
D-3	Coupler	<input type="checkbox"/>	<input type="checkbox"/>	<input type="checkbox"/>

Checklist E		Y	N	R
E-1	Cable	<input type="checkbox"/>	<input type="checkbox"/>	<input type="checkbox"/>
<b>Perform every 2000 hours:</b>				
E-2	Engine maintenance	<input type="checkbox"/>	<input type="checkbox"/>	<input type="checkbox"/>
<b>Perform every 3000 hours:</b>				
E-3	Engine maintenance	<input type="checkbox"/>	<input type="checkbox"/>	<input type="checkbox"/>
<b>Perform every 10,000 hours:</b>				
E-4	Generator maintenance	<input type="checkbox"/>	<input type="checkbox"/>	<input type="checkbox"/>
<b>Perform every 20,000 hours:</b>				
E-5	Generator maintenance	<input type="checkbox"/>	<input type="checkbox"/>	<input type="checkbox"/>
<b>Perform every 30,000 hours:</b>				
E-6	Generator maintenance	<input type="checkbox"/>	<input type="checkbox"/>	<input type="checkbox"/>

Comments \_\_\_\_\_

## Checklist A Procedures

### A-1 Inspect the Manuals and Decals



Terex specifications require that this procedure be performed every 8 hours or daily, whichever comes first.

Maintaining the operator's and safety manuals in good condition is essential to safe machine operation. Manuals are included with each machine and should be stored in the container provided in the platform. An illegible or missing manual will not provide safety and operational information necessary for a safe operating condition.

In addition, maintaining all of the safety and instructional decals in good condition is mandatory for safe machine operation. Decals alert operators and personnel to the many possible hazards associated with using this machine. They also provide users with operation and maintenance information. An illegible decal will fail to alert personnel of a procedure or hazard and could result in unsafe operating conditions.

- 1 Check to make sure that the operator's and safety manuals are present and complete in the storage container inside the cabinet.

- 2 Examine the pages of each manual to be sure that they are legible and in good condition.
  - ⊙ Result: The operator's manual is appropriate for the machine and all manuals are legible and in good condition.
  - ⊗ Result: The operator's manual is not appropriate for the machine or all manuals are not in good condition or is illegible. Remove the machine from service until the manual is replaced.
- 3 Open the operator's manual to the decals inspection section. Carefully and thoroughly inspect all decals on the machine for legibility and damage.
  - ⊙ Result: The machine is equipped with all required decals, and all decals are legible and in good condition.
  - ⊗ Result: The machine is not equipped with all required decals, or one or more decals are illegible or in poor condition. Remove the machine from service until the decals are replaced.
- 4 Always return the manuals to the storage container after use.

Note: Contact your authorized Terex distributor or Terex if replacement manuals or decals are needed.

## Checklist A Procedures

### A-2 Perform Pre-operation Inspection



Terex specifications require that this procedure be performed every 8 hours or daily, whichever comes first.

Completing a Pre-operation Inspection is essential to safe machine operation. The Pre-operation Inspection is a visual inspection performed by the operator prior to each work shift. The inspection is designed to discover if anything is apparently wrong with a machine before the operator performs the function tests. The Pre-operation Inspection also serves to determine if routine maintenance procedures are required.

Complete information to perform this procedure is available in the appropriate operator's manual. Refer to the Operator's Manual on your machine.

### A-3 Perform Function Tests



Terex specifications require that this procedure be performed every 8 hours or daily, whichever comes first.

Completing the function tests is essential to safe machine operation. Function tests are designed to discover any malfunctions before the machine is put into service. A malfunctioning machine must never be used. If malfunctions are discovered, the machine must be tagged and removed from service.

Complete information to perform this procedure is available in the appropriate operator's manual. Refer to the Operator's Manual on your machine.



## Checklist A Procedures

### A-4 Perform Engine Maintenance



Engine specifications require that this procedure be performed every 8 hours or daily, whichever comes first.

- Engine oil level – check
- Coolant level – check/add
- Fuel system filter/water separator – drain
- Engine tightness – check for leaks
- Exhaust system – check for leaks
- Loose or missing fasteners

Required maintenance procedures and additional engine information is available in the Kubota D1105-E and V1505-E Operator's Manual (Kubota 16683-89169 part number ) OR the Kohler KDW1003 Engine Owner's Manual (Kohler part number ED0053028440).

---

#### Kohler KDW1003 Engine Owner's Manual

Genie part number 1268769

---

#### Kubota D-1105 and V-1505 Operator's Manual

Genie part number 893020

---

### A-5 Perform Coupler Maintenance



Coupler specifications require that this procedure be performed before towing.

Maintaining the coupler in good condition is essential to safe operation and good performance. Coupler failure could result in a machine tip-over during transport, and component damage may also result if problems are not discovered and repaired in a timely fashion.

- 1 Check vehicle, mounting bracket, hitch ball and coupler for signs of wear or damage and that the coupler handle opens and closes freely.
  - ⊙ Result: if coupler and/or mounting bracket is deformed or damaged, replace complete coupler and mounting bracket. Replace bent, broken or worn parts before use.
- 2 Close coupler securely by ensuring that the hitch ball is fully seated in the coupler ball pocket and the pin is inserted behind the collar or latch.
- 3 Check mounting bracket hardware for wear and proper tightness.
  - ⊗ Result: Replace bent, broken or worn hardware.

## Checklist A Procedures

### A-6

#### Test the Brakes (if equipped)



Axle specifications require that this procedure be performed before towing.

Maintaining the axle brakes in good condition is essential to safe operation and good performance. Brakes which are out of adjustment can result in longer stopping distances and excessive brake wear on the towing vehicle. Component damage may also result if problems are not discovered and repaired in a timely fashion.

Test the brakes for proper function. Repair or replace any faulty components as needed.

### A-7

#### Torque the Wheel Lug Nuts



Axle specifications require that this procedure be performed initially at 10, 25 and 50 miles of use, or after reinstallation of a tire.

Maintaining the wheel lug nuts at proper torque is essential to safe operation and good service life of the tires, wheel and axle.

- 1 Check each lug nut for proper torque. Refer to Specifications, Machine Specifications.

## Checklist A Procedures

### A-8 Check the Tires and Wheels



Axle specifications require that this procedure be performed weekly.

Maintaining the tires and wheels in good condition and the tires at the correct pressure is essential to safe operation and good performance. Tire and/or wheel failure could result in a machine tip-over. Component damage may also result if problems are not discovered and repaired in a timely fashion.

**⚠ WARNING** Bodily injury hazard. An over-inflated tire can explode and could cause death or serious injury.

**⚠ WARNING** Tip-over hazard. Do not use temporary flat tire repair products.

- 1 Check tire surface and sidewalls for cuts, cracks, punctures and unusual wear.
- 2 Check each wheel for damage, bends and cracks.
- 3 Check the pressure in each air-filled tire. Refer to Specifications, Machine Specifications.

### A-9 Inspect the Engine Air Filter



Terex specifications require that this procedure be performed every 40 hours or weekly, whichever comes first.

Maintaining the engine air filter in good condition is essential to good engine performance and service life. Failure to perform this procedure can lead to poor engine performance and component damage.

Note: Perform this procedure with the engine off.

- 1 Open the engine side cover. Empty the dust discharge valve by pressing together the sides of the discharge slot. Clean the discharge slot as needed.

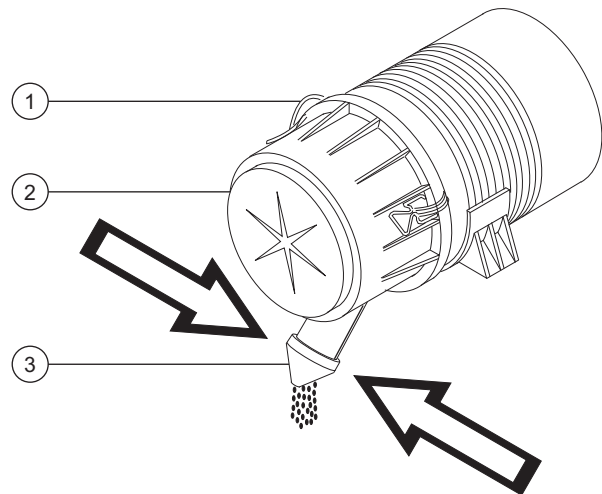

- 1 clamp
- 2 cannister end cap
- 3 dust discharge valve

## Checklist A Procedures

- 2 Release the latches on the air cleaner cap. Remove the end cap from the air cleaner canister.
- 3 Remove the filter element.
- 4 Use a damp cloth to wipe the filter sealing surface and the inside of the outlet tube. Make sure that all contaminant is removed before the filter is inserted.
- 5 Check new filter element gasket for damage before installing.
- 6 Install the new filter element.
- 7 Install the end cap on the canister and secure.

Note: Be sure the discharge slot is pointing down.

### A-10

#### Perform Generator Maintenance



Generator specifications require that this procedure be performed every 40 hours or weekly, whichever comes first.

- Clean and inspect the generator exterior
- Clean and replace the generator air filters - (if equipped)

---

#### Coliseum Manual

Genie part number

1268770

---

## Checklist A Procedures

### A-11 Perform Engine Maintenance



Engine specifications require that this procedure be performed every 100 hours.

- Check fuel lines and clamps

Required maintenance procedures and additional engine information is available in the Kubota D1105-E and V1505-E Operator's Manual (Kubota 16683-89169 part number ) OR the Kohler KDW1003 Engine Owner's Manual (Kohler part number ED0053028440).

---

#### Kohler KDW1003 Engine Owner's Manual

Genie part number 1268769

---

#### Kubota D-1105 and V-1505 Operator's Manual

Genie part number 893020

---

### A-12 Perform Engine Maintenance



Engine specifications require that this procedure be performed every 200 hours.

- Change engine oil
- Replace oil filter

Required maintenance procedures and additional engine information is available in the Kubota D1105-E and V1505-E Operator's Manual (Kubota 16683-89169 part number ) OR the Kohler KDW1003 Engine Owner's Manual (Kohler part number ED0053028440).

---

#### Kohler KDW1003 Engine Owner's Manual

Genie part number 1268769

---

#### Kubota D-1105 and V-1505 Operator's Manual

Genie part number 893020

---

## Checklist A Procedures

### A-13 Inspect the Cables and Cable Pulleys



Terex specifications require that this procedure be performed monthly.

Detection of damage to the cables or pulleys is essential for safe machine operation. An unsafe working condition exists if these components are damaged and do not operate smoothly. Regular inspection of this system allows the inspector to identify changes in the operating condition that may indicate damage.

- 1 Visually inspect the electric winch and cable pulleys for the following:
  - broken or damaged pulleys
  - unusual or excessive pulley wear

⊙ Result: A pulley is broken or damaged, or shows unusual or excessive pulley wear. The pulley must immediately be replaced.
- 2 Put on protective leather gloves and eye wear.
- 3 Fully unwind the cable from the winch.
- 4 Wearing leather gloves, run a hand up and down a length of the cable, inspecting the cable and components for the following:
  - frayed or broken wire strands

⊙ Result: In any given one-foot of cable length there are 4 or more broken wires on any 2 or more strands. The cable must immediately be replaced.
- 5 Visually inspect the winch cable for the following:
  - nicks (partial strand cut through)
  - kinks in the cable (permanent bends)
  - weld splatter

⊙ Result: Nicks, kinks in the cable or weld splatter are. The cable must immediately be replaced.
- 6 Visually inspect the winch cable for the following:
  - crushed spot on the cable

⊙ Result: A crushed spot on the cable measuring 125% of the cable diameter or more is found OR there is a broken wire at the crush point. The cable must immediately be replaced.
- 7 Wind cable onto the winch, ensuring that the cable is correctly installed onto each of the pulleys.

## Checklist A Procedures

### A-14 Perform Engine Maintenance



Engine specifications require that this procedure be performed every 100 hours.

- Clean air filter
- Clean the fuel filter
- Inspect fan belt

Required maintenance procedures and additional engine information is available in the Kubota D1105-E and V1505-E Operator's Manual (Kubota 16683-89169 part number ) OR the Kohler KDW1003 Engine Owner's Manual (Kohler part number ED0053028440).

---

#### Kohler KDW1003 Engine Owner's Manual

Genie part number 1268769

---

#### Kubota D-1105 and V-1505 Operator's Manual

Genie part number 893020

---

### A-15 Perform Engine Maintenance



Engine specifications require that this procedure be performed every 200 hours.

- Change engine oil
- Replace oil filter
- Inspect radiator hoses and clamps
- Inspect air intake hose

Required maintenance procedures and additional engine information is available in the Kubota D1105-E and V1505-E Operator's Manual (Kubota 16683-89169 part number ) OR the Kohler KDW1003 Engine Owner's Manual (Kohler part number ED0053028440).

---

#### Kohler KDW1003 Engine Owner's Manual

Genie part number 1268769

---

#### Kubota D-1105 and V-1505 Operator's Manual

Genie part number 893020

---

## Checklist A Procedures

### A-16 Perform Generator Maintenance



Generator specifications require that this procedure be performed every 200 hours or quarterly, whichever comes first.

- Clean and inspect the generator exterior
- Check for loose or damaged wires and components.

**⚠ WARNING** Electrocutation/burn hazard. Contact with electrically charged circuits could result in death or serious injury. Remove all rings, watches and other jewelry.

---

#### Coliseum Manual

Genie part number

1268770

---

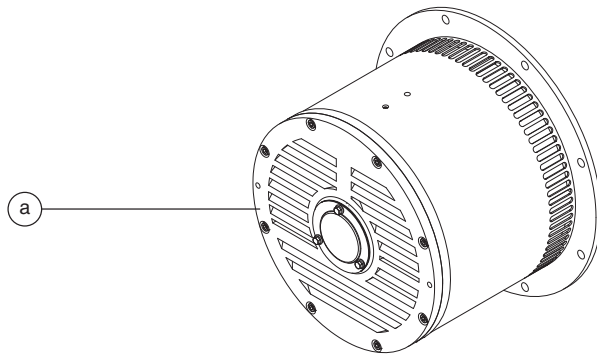

a generator

### A-17 Drain the Fuel Filter/Water Separator

Terex specifications require that this procedure be performed every 200 hours or monthly, whichever comes first.

Proper maintenance of the fuel filter/water separator is essential for good engine performance. Failure to perform this procedure can lead to poor engine performance and component damage.

**⚠ DANGER** Explosion and fire hazard. Engine fuels are combustible. Perform this procedure in an open, well-ventilated area away from heaters, sparks, flames and lighted tobacco. Always have an approved fire extinguisher within easy reach.

- 1 Locate the fuel filter/water separator and loosen the vent plug located on the fuel filter/water separator head.



## Checklist A Procedures

- 2 Loosen the drain plug located at the bottom of the bowl. Allow the water to drain into a suitable container until fuel starts to come out. Immediately tighten the drain plug.

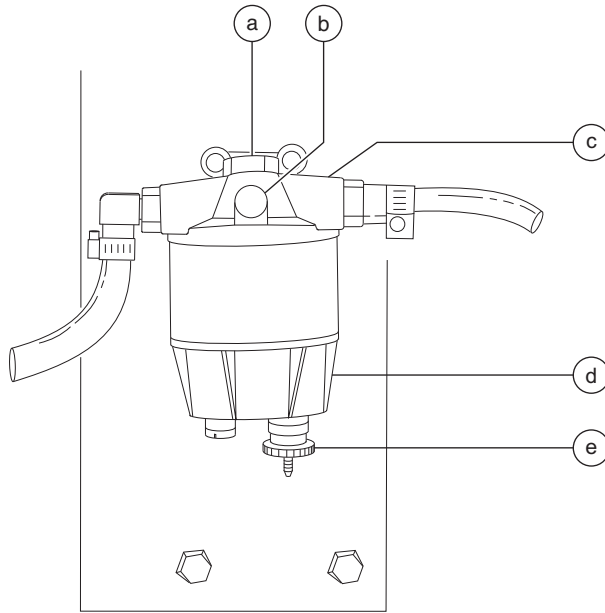

- a head bolt
- b vent plug
- c separator head
- d filter bowl
- e drain plug

- 3 Tighten the vent plug and clean up any spills or wet surfaces.  
 Note: If the fuel bowl is completely drained, you must prime, or bleed, the fuel filter/water separator before starting the engine. See step 5.
- 4 Start the engine from the electrical control panel and check the fuel filter/water separator for leaks.

### Bleed the fuel system:

- 5 Loosen the vent plug/screw located on the filter head.
- 6 Operate the hand primer until fuel, free of air, flows from the vent plug/screw. Tighten the vent plug/screw on the filter head.
- 7 Loosen the vent screw, located on top of the fuel injection pump.
- 8 Operate the hand primer until fuel, free of air, flows from the vent plug/screw. Tighten the vent plug/screw on the injection pump.
- 9 Clean up any fuel that may have spilled.
- 10 Attempt to start the engine using the starter motor for a maximum of 15 seconds, resting the starter for 30 seconds before trying again.
- 11 Inspect the fuel filter/water separator for leaks.

### **⚠ DANGER**

Explosion and fire hazard. If a fuel leak is discovered, keep any additional personnel from entering the area and do not operate the machine. Repair the leak immediately.

Note: Required maintenance procedures and additional engine information is available in the Kubota D1105-E and V1505-E Operator's Manual (Kubota 16683-89169 part number ) OR the Kohler KDW1003 Engine Owner's Manual (Kohler part number ED0053028440).

#### **Kohler KDW1003 Engine Owner's Manual**

Genie part number 1268769

#### **Kubota D-1105 and V-1505 Operator's Manual**

Genie part number 893020

## Checklist A Procedures

### A-18

#### Test the Brakes (if equipped)



Axle specifications require that this procedure be performed initially at 250 miles of use.

Maintaining the axle brakes in good condition is essential to safe operation and good performance. Brakes which are out of adjustment can result in longer stopping distances and excessive brake wear on the towing vehicle. Component damage may also result if problems are not discovered and repaired in a timely fashion.

Note: Perform this procedure with the machine on a firm, level surface with the machine in the stowed position.

- 1 Select a wheel. Chock the front and rear of the tire at the opposite side of the machine.
- 2 Place a lifting jack under the axle near the brake to be adjusted. Lift the axle until the wheel is off the ground and place a jack stand under the axle. Lower the axle onto the jack stand.
- 3 Working from the back side of the wheel at the brake backing plate, locate and remove the small rubber plug from the lower side of the backing plate to access the star-shaped brake adjuster wheel. Set the plug to the side.
- 4 Insert a brake adjuster tool into the opening of the brake backing plate, engaging it with the teeth of the brake adjuster wheel. Move the tip of the adjuster tool in an upwards direction to tighten the brakes.
 

Note: It may be helpful to use a flashlight when locating the brake adjuster wheel.
- 5 Repeatedly move the tip of the adjuster tool in an upwards direction to tighten the brakes until the wheel locks up and will no longer turn.
 

Note: This centers the brake shoes on the brake drum, ensuring the shoes are positioned correctly.
- 6 Move the tip of the adjuster tool in a downwards direction 3 to 5 clicks to loosen the brakes only until the wheel spins freely with little drag.
- 7 Securely install the small rubber plug into the brake backing plate.
- 8 Check the wheel bearing wear by attempting to move wheel hub side to side, then up and down.
  - ⊙ There is no side to side or up and down movement. The bearing is good.
  - ⊗ There is side to side or up and down movement. The bearing must be adjusted or replaced. See B-8, Inspect and Adjust the Brakes (if equipped).
- 9 Lift the axle slightly. Remove the jack stand and lower the machine to the ground. Chock the front and rear of the tire.
- 10 Repeat this procedure, beginning with step 2, for the other wheel.

## Checklist B Procedures

### B-1 Inspect the Engine Start Battery



Terex specifications require that this procedure be performed every 250 hours or quarterly, whichever comes first.

Proper battery condition is essential to good engine performance and operational safety. Improper fluid levels or damaged cables and connections can result in engine component damage and hazardous conditions.

**▲ WARNING** Electrocution/burn hazard. Contact with electrically charged circuits could result in death or serious injury. Remove all rings, watches and other jewelry.

**▲ WARNING** Bodily injury hazard. Batteries contain acid. Avoid spilling or contacting battery acid. Neutralize battery acid spills with baking soda and water.

Note: Fully charge the batteries and allow the batteries to rest 24 hours before performing this procedure to allow the battery cells to equalize.

- 1 Open the side covers.
- 2 Be sure that the battery cable connections are free of corrosion.

Note: Adding terminal protectors and a corrosion preventative sealant will help eliminate corrosion on the battery terminals and cables.

- 3 Be sure that the battery retainers and cable connections are tight.
- 4 Be sure that the battery separator wire connections are tight (if equipped).

#### Models without maintenance-free or sealed batteries:

- 5 Put on protective clothing and eye wear.
- 6 Remove the battery vent caps and check the specific gravity of each battery cell with a hydrometer. Note the results.
- 7 Check the ambient air temperature and adjust the specific gravity reading for each cell as follows:
  - Add 0.004 to the reading of each cell for every 10° F / 5.5° C above 80° F / 26.7° C.
  - Subtract 0.004 from the reading of each cell for every 10° F / 5.5° C below 80° F / 26.7° C.
- ☉ Result: All battery cells display an adjusted specific gravity of 1.277 or higher. The battery is fully charged. Proceed to step 11.
- ☒ Result: One or more battery cells display a specific gravity of 1.276 or below. Proceed to step 8.
- 8 Perform an equalizing charge OR fully charge the battery(s) and allow the battery(s) to rest at least 6 hours.
- 9 Remove the battery vent caps and check the specific gravity of each battery cell with a hydrometer. Note the results.

## Checklist B Procedures

- 10 Check the ambient air temperature and adjust the specific gravity reading for each cell as follows:
- Add 0.004 to the reading of each cell for every 10° F / 5.5° C above 80° F / 26.7° C.
  - Subtract 0.004 from the reading of each cell for every 10° F / 5.5° C below 80° F / 26.7° C.
- ⊙ Result: All battery cells display a specific gravity of 1.277 or greater. The battery is fully charged. Proceed to step 11.
- ⊗ Result: One or more battery cells display a specific gravity from 1.218 to 1.269. The battery is still usable, but at a lower performance. The battery will need to be recharged more often. Proceed to step 11.
- ⊗ Result: One or more battery cells display a specific gravity from 1.217 to 1.173. The battery is approaching the end of its life. Proceed to step 11.
- ⊗ Result: The difference in specific gravity readings between cells is greater than 0.1 OR the specific gravity of one or more cells is less than 1.177. Replace the battery.
- 11 Check the battery acid level. If needed, replenish with distilled water to 1/8 inch / 3 mm below the bottom of the battery fill tube. Do not overfill.
- 12 Install the vent caps and neutralize any electrolyte that may have spilled.
- 13 Close the side covers.

### B-2

## Inspect the Electrical Wiring



Terex specifications require that this procedure be performed every 250 hours or quarterly, whichever comes first.

Maintaining electrical wiring in good condition is essential to safe operation and good machine performance. Failure to find and replace burnt, chafed, corroded or pinched wires could result in unsafe operating conditions and may cause component damage.

### ⚠ WARNING

Electrocution/burn hazard. Contact with electrically charged circuits could result in death or serious injury. Remove all rings, watches and other jewelry.

- 1 Inspect the following areas for burnt, chafed, corroded pinched and loose wires:
  - Ground controls
  - Battery
  - Engine
  - Mast
  - Lighting junction box
  - Trailer lighting wire harness
- 2 Inspect for a liberal coating of dielectric grease in the following locations:
  - Lighting junction box
  - Ground controls
  - All wire harness connectors

## Checklist B Procedures

### B-3

#### Torque the Wheel Lug Nuts



Axle specifications require that this procedure be performed initially at 10, 25 and 50 miles of use, or after reinstallation of a tire.

Maintaining the wheel lug nuts at proper torque is essential to safe operation and good service life of the tires, wheel and axle.

- 1 Check each lug nut for proper torque. Refer to Specifications, Machine Specifications.

### B-4

#### Perform Engine Maintenance



Engine specifications require that this procedure be performed every 250 hours or six months, whichever comes first.

- Inspect alternator and fan belts

Required maintenance procedures and additional engine information is available in the Kubota D1105-E and V1505-E Operator's Manual (Kubota 16683-89169 part number ) OR the Kohler KDW1003 Engine Owner's Manual (Kohler part number ED0053028440).

---

#### Kohler KDW1003 Engine Owner's Manual

Genie part number 1268769

---

#### Kubota D-1105 and V-1505 Operator's Manual

Genie part number 893020

---

## Checklist B Procedures

### B-5 Perform Jack Maintenance



Jack specifications require that this procedure be performed every 250 hours or quarterly, whichever comes first.

Maintaining the jack is essential to good machine performance and safe operation. An unsafe working condition exists if the jack has excessive wear and/or does not operate smoothly, free of hesitation and binding.

- 1 Select a jack.
- 2 Remove the cover from the top of the jack.
- 3 Apply a small amount of automotive grease to the internal gearing, and rotate the handle several times to evenly distribute the grease.
- 4 Apply a few drops of light oil to the jack handle where it makes contact with the outside of the jack tube.
- 5 Securely install the cover onto the jack.
- 6 Repeat this procedure, beginning with step 1, for the other jackson the machine.

### B-6 Inspect and Lubricate the Winch



Terex specifications require that this procedure be performed every 250 hours or quarterly, whichever comes first.

Maintaining the winch is essential to good machine performance and safe operation. An unsafe working condition exists if the winch has excessive wear and/or does not operate smoothly, free of hesitation and binding.

- 1 Carefully lubricate the winch.

## Checklist B Procedures

### B-7 Lubricate the T-bolt



Terex specifications require that this procedure be performed every 250 hours or quarterly, whichever comes first.

Maintaining the T-bolt is essential to good machine performance and safe operation. An unsafe working condition exists if the T-bolt has excessive wear and/or does not operate smoothly, free of hesitation and binding.

- 1 Using the illustration as a guide, locate the T-bolt at the bottom of the mast assembly. Remove the T-bolt from the mast.
- 2 Remove all dust, dirt and oil residue from the threaded surfaces of the T-bolt, and apply a few drops of light oil or thread lubricant onto the threaded surfaces.
- 3 Fully install the T-bolt into the mast.

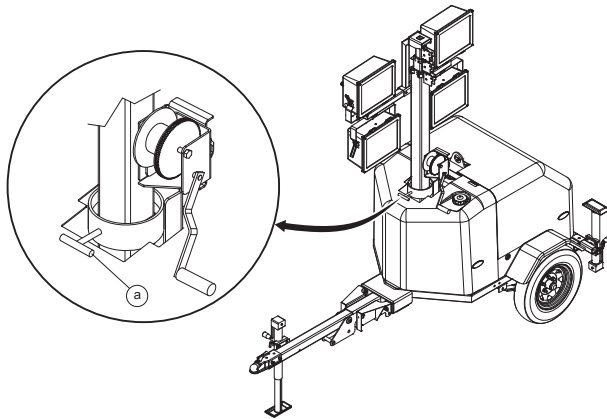

a T-bolt

### B-8 Inspect and Adjust the Brakes (if equipped)



Axle specifications require that this procedure be performed every 3000 miles or quarterly, whichever comes first.

Maintaining the axle brakes in good condition is essential to safe operation and good performance. Brakes which are out of adjustment can result in longer stopping distances and excessive brake wear on the towing vehicle. Component damage may also result if problems are not discovered and repaired in a timely fashion.

Note: Perform this procedure with the machine on a firm, level surface with the machine in the stowed position.

- 1 Select a wheel. Chock the front and rear of the tire at the opposite side of the machine.
- 2 Loosen the wheel lug nuts. Do not remove them.
- 3 Place a lifting jack under the axle near the wheel to be removed. Lift the axle until the wheel is off the ground and place a jack stand under the axle. Lower the axle onto the jack stand and remove the wheel.
- 4 Remove the dust cap from the hub. Remove the cotter pin from the castle nut.
- 5 Remove the castle nut and washer.
- 6 Pull the hub off of the spindle. The washer and outer bearing should fall loose from the hub.

## Checklist B Procedures

7 Inspect the brake lining for wear (if equipped).

- ⦿ Result: the thickness of the brake lining is greater than 1/16 inch / 1.6 mm. The brake shoes are good.
- ⊗ Result: the thickness of the brake lining is 1/16 inch / 1.6 mm or less. The brake shoes must be replaced and the brake drums must be inspected for wear, scoring and other damage.

Note: The maximum bore of a good brake drum shall not be greater than 0.090 inch / 2.29 mm in excess of the drum diameter.

Note: If drum resurfacing is required, the brake drum should be resurfaced to a 120 micron finish.

Note: If replacing the brake shoes, apply a light coat of grease or anti-seize compound to the anchor pin, arm bushing and pin, and areas of the backing plate which contact the magnet arm and brake shoes frame. Apply a small amount of lube to the actuating cam at the top of the magnet arm. Do not allow grease or oil to contact the brakes shoes or the inside of the drum.

8 Slide the hub onto the yoke spindle.

**NOTICE** Component damage hazard. Do not apply excessive force or damage to the lip of the seal may occur.

9 Place the outer bearing into the hub.

10 Install the washer and the castle nut.

11 Tighten the castle nut to 50 ft-lbs / 68 Nm to seat the bearings.

12 Fully loosen the castle nut. Do not rotate the hub.

13 Finger tighten the castle nut until snug.

14 Install a new cotter pin. Bend the cotter pin to lock it in place.

Note: Always replace the cotter pin with a new one when removing the castle nut.

15 Install the dust cap, then the tire and wheel assembly. Torque the wheel lug nuts to specification. Refer to Section 2, Specifications.

16 Working from the back side of the wheel at the brake backing plate, locate and remove the small rubber plug from the lower side of the backing plate to access the star-shaped brake adjuster wheel. Set the plug to the side.

17 Insert a brake adjuster tool into the opening of the brake backing plate, engaging it with the teeth of the brake adjuster wheel. Move the tip of the adjuster tool in an upwards direction to tighten the brakes.

Note: It may be helpful to use a flashlight when locating the brake adjuster wheel.

18 Repeatedly move the tip of the adjuster tool in an upwards direction to tighten the brakes until the wheel locks up and will no longer turn.

Note: This centers the brake shoes on the brake drum, ensuring the shoes are positioned correctly.

19 Move the tip of the adjuster tool in a downwards direction 3 to 5 clicks to loosen the brakes only until the wheel spins freely with little drag.



## Checklist B Procedures

- 20 Securely install the small rubber plug into the brake backing plate.
- 21 Check the wheel bearing wear by attempting to move wheel hub side to side, then up and down.
  - ⦿ There is no side to side or up and down movement. The bearing is good.
  - ⊗ There is side to side or up and down movement. The bearing must be adjusted or replaced. See B-8, Inspect and Adjust the Brakes (if equipped).
- 22 Lift the axle slightly. Remove the jack stand and lower the machine to the ground. Chock the front and rear of the tire.
- 23 Repeat this procedure, beginning with step 2, for the other wheel.

### B-9

#### Inspect the Suspension



Axle specifications require that this procedure be performed every 3000 miles or quarterly, whichever comes first.

Maintaining the axle suspension in good condition is essential to safe operation and good performance. Towing the machine with worn or damaged suspension components could result in a tip-over. Component damage may also result if problems are not discovered and repaired in a timely fashion.

- 1 Working with a flashlight or in a well lit shop, carefully inspect all suspension components and fasteners. Replace as necessary.

## Checklist B Procedures

### B-10

#### Perform Engine Maintenance



Engine specifications require that this procedure be performed every 400 hours or semi-annually, whichever comes first.

- Replace oil filter
- Replace fuel filter

Required maintenance procedures and additional engine information is available in the Kubota D1105-E and V1505-E Operator's Manual (Kubota 16683-89169 part number ) OR the Kohler KDW1003 Engine Owner's Manual (Kohler part number ED0053028440).

---

#### **Kohler KDW1003 Engine Owner's Manual**

Genie part number 1268769

---

#### **Kubota D-1105 and V-1505 Operator's Manual**

Genie part number 893020

---

## Checklist C Procedures

### C-1

### Perform Engine Maintenance



Engine specifications require that this procedure be performed every 500 hours.

- Replace fan belts
- Flush coolant system
- Clean fuel tank

Required maintenance procedures and additional engine information is available in the Kubota D1105-E and V1505-E Operator's Manual (Kubota 16683-89169 part number ) OR the Kohler KDW1003 Engine Owner's Manual (Kohler part number ED0053028440).

---

#### **Kohler KDW1003 Engine Owner's Manual**

Genie part number 1268769

---

#### **Kubota D-1105 and V-1505 Operator's Manual**

Genie part number 893020

---

## Checklist C Procedures

### C-2 Clean the Light Assemblies



Terex specifications require that this procedure be performed every 500 hours or semi-annually, whichever comes first.

Maintaining the light assemblies is essential to good machine performance. Failure to regularly clean the light assemblies may result in less light than expected and, over time, could result in damage to the machine.

Note: Perform this procedure with the light assemblies out of direct sunlight and cool to the touch.

- 1 Use clean, cool water to rinse the surface of each light assembly.
- 2 Clean each light assembly using a soft cloth, water and a mild dishwashing detergent.

**NOTICE** Component damage hazard. Harsh chemicals and cleaning agents will damage the surface of the light assembly. Do not allow harsh cleaning agents to make contact with the light surface..

- 3 Thoroughly rinse, then dry with a soft cloth.

### C-3 Grease the Wheel Bearings



Axle specifications require that this procedure be performed every 6,000 hours or semi-annually, whichever comes first.

Maintaining the axle wheel bearings is essential to safe machine operation and service life. Operating a machine with loose or worn wheel bearings may cause an unsafe operating condition and continued use may result in component damage. Extremely wet or dry conditions or regular steam cleaning and pressure washing of the machine may require that this procedure be performed more often.

Note: Perform this procedure with the machine on a firm, level surface with the machine in the stowed position.

- 1 Select a wheel. Chock the front and rear of the tire at the opposite side of the machine.
- 2 Loosen the wheel lug nuts. Do not remove them.
- 3 Place a lifting jack under the axle near the wheel to be removed. Lift the axle until the wheel is off the ground and place a jack stand under the axle. Lower the axle onto the jack stand and remove the wheel.
- 4 Remove the dust cap from the hub. Remove the cotter pin from the castle nut.

## Checklist C Procedures

- 5 Remove the castle nut and washer.
- 6 Pull the hub off of the spindle. The washer and outer bearing should fall loose from the hub.
- 7 Place the hub on a flat surface and gently pry the bearing seal out of the hub. Remove the rear bearing.
- 8 Pack both bearings with clean, fresh grease.
- 9 Inspect the hub for wear. Replace if necessary.
- 10 Place the large inner bearing into the rear of the hub.
- 11 Install a new bearing grease seal into the hub by pressing it evenly into the hub until it is flush.

Note: Always replace the bearing grease seal when removing the hub.

- 12 Inspect the brake lining for wear (if equipped).
- 13 Inspect the brake cylinder for leaks (if equipped).
- 14 Inspect the brake springs for wear or loss of arch (if equipped).
- 15 Inspect the brake wiring/hoses for wear (if equipped).

- 16 Slide the hub onto the yoke spindle.

**NOTICE**

Component damage hazard. Do not apply excessive force or damage to the lip of the seal may occur.

- 17 Place the outer bearing into the hub.
- 18 Install the washer and the castle nut.
- 19 Tighten the castle nut to 50 ft-lbs / 68 Nm to seat the bearings.
- 20 Fully loosen the castle nut. Do not rotate the hub.
- 21 Finger tighten the castle nut until snug.
- 22 Install a new cotter pin. Bend the cotter pin to lock it in place.

Note: Always replace the cotter pin with a new one when removing the castle nut.

- 23 Install the dust cap, then the tire and wheel assembly. Torque the wheel lug nuts to specification. Refer to Section 2, Specifications.

## Checklist C Procedures

### C-4

#### Inspect the Electric Brake Magnets (if equipped)



Axle specifications require that this procedure be performed every 6,000 hours or semi-annually, whichever comes first.

Maintaining the axle brakes in good condition is essential to safe operation and good performance. A faulty brake magnet can severely impact the stopping power of a trailer. While some magnet problems will be apparent upon visual inspection, there may also be electrical problems that can impact performance. A failing or faulty brake magnet can lead to weak or surging brakes, or cause the brakes to pull to one side. It is important to inspect and test the magnets at regular intervals to ensure maximum effectiveness.

- 1 Connect the electric brake wire harness to a tow vehicle capable of towing the machine.
- 2 Start the engine of the tow vehicle, and press down on the brake pedal.
  - ⊕ Result: An audible 'click' is noted at each brake when the brake magnet is activated and pulls itself into contact with the brake drum. The brake circuit is functioning correctly.
  - ⊗ Result: An audible 'click' is not noted at each brake because the brake magnet is not activated and does not make contact with the brake drum. The brake circuit is faulty. Inspect the wire harness and harness connections and repair as required, and repeat this procedure beginning with step 2.
- 3 With the engine running, press down on the brake pedal and use a multimeter to measure the total amp draw of the brake circuit by positioning an amp clamp around the brake wire lead near the trailer connector. Note the reading.
  - ⊕ Result: The total amp draw measures 5.5 to 6.0 amps. The brake circuit is functioning correctly.
  - ⊗ Result: The total amp draw measures less than 5.5 amps. Replace the magnets and magnet springs on both sides of the axle, and resurface the brake drums. Repeat this procedure beginning with step 4.
- 4 Stop the engine of the tow vehicle.
- 5 Select a wheel. Chock the front and rear of the tire at the opposite side of the machine.
- 6 Loosen the wheel lug nuts. Do not remove them.
- 7 Place a lifting jack under the axle near the wheel to be removed. Lift the axle until the wheel is off the ground and place a jack stand under the axle. Lower the axle onto the jack stand and remove the wheel.
- 8 Remove the dust cap from the hub. Remove the cotter pin from the castle nut.
- 9 Remove the castle nut and washer.
- 10 Pull the hub off of the spindle. The washer and outer bearing should fall loose from the hub.

## Checklist C Procedures

- 11 Locate the brake magnet. Inspect the surface of the magnet for pitting and any irregular surface wear.
- ⊗ Result: Replace the magnets and magnet springs on both sides of the axle if pitting or any irregular surface wear is detected, and resurface the brake drums.
- 12 Inspect the copper coil at the center of the magnet.
- ⊗ Result: Replace the magnets and magnet springs on both sides of the axle if the exposed copper coil is visible in any way, and resurface the brake drums.
- 13 Slide the hub onto the yoke spindle.

### NOTICE

Component damage hazard. Do not apply excessive force or damage to the lip of the seal may occur.

- 14 Place the outer bearing into the hub.
- 15 Install the washer and the castle nut.
- 16 Tighten the castle nut to 50 ft-lbs / 68 Nm to seat the bearings.
- 17 Fully loosen the castle nut. Do not rotate the hub.
- 18 Finger tighten the castle nut until snug.
- 19 Install a new cotter pin. Bend the cotter pin to lock it in place.

Note: Always replace the cotter pin with a new one when removing the castle nut.

- 20 Install the dust cap, then the tire and wheel assembly. Torque the wheel lug nuts to specification. Refer to Section 2, Specifications.
- 21 Repeat this procedure, beginning with step 6, for the other side of the machine.

### C-5

#### Perform Engine Maintenance



Engine specifications require that this procedure be performed every 800 hours or annually, whichever comes first.

- Replace air filter
- Inspect wiring
- Check valve clearance

Required maintenance procedures and additional engine information is available in the Kubota D1105-E and V1505-E Operator's Manual (Kubota 16683-89169 part number ) OR the Kohler KDW1003 Engine Owner's Manual (Kohler part number ED0053028440).

---

#### Kohler KDW1003 Engine Owner's Manual

Genie part number	1268769
-------------------	---------

---

#### Kubota D-1105 and V-1505 Operator's Manual

Genie part number	893020
-------------------	--------

---

---

## Checklist C Procedures

### C-6

#### Perform Generator Maintenance



Generator specifications require that this procedure be performed every 2000 hours or semi-annually, whichever comes first.

Maintaining the generator in good condition is essential to safe operation and long service life. Storing the generator in a harsh environment may require this procedure be performed more frequently. Loose or damaged connections or components may result in a generator to lose efficiency, and reduce the life of the generator.

- Inspect stator output leads and insulation for cracking and damage.
- Inspect exposed electrical for loose or damaged connections.
- Inspect transformers, fuses, capacitors and lightning arrestors for loose or damaged component connections.
- Inspect all wire and electrical connections for proper clearance..
- Inspect and clean inside of outlet box, air screens and air baffles with compressed air.
- Inspect for machine vibration and bearing wear.

---

#### Coliseum Manual

Genie part number

1268770

---



---

## Checklist D Procedures

### D-1

### Perform Engine Maintenance



Engine specifications require that this procedure be performed every 1500 hours or bi-annually, whichever comes first.

- Injectors

Required maintenance procedures and additional engine information is available in the Kubota D1105-E and V1505-E Operator's Manual (Kubota 16683-89169 part number ) OR the Kohler KDW1003 Engine Owner's Manual (Kohler part number ED0053028440).

---

**Kohler KDW1003 Engine Owner's Manual**

Genie part number 1268769

---

**Kubota D-1105 and V-1505 Operator's Manual**

Genie part number 893020

---

## Checklist D Procedures

### D-2

#### Perform Generator Maintenance



Generator specifications require that this procedure be performed every 8000 hours or annually, whichever comes first.

Maintaining the generator in good condition is essential to safe operation and long service life. Storing the generator in a harsh environment may require this procedure be performed more frequently. Poor resistance may result in a generator to lose efficiency, and reduce the life of the generator.

- Check resistance to ground on generator windings, main rotating assembly, stator, exciter field and armature.

---

#### Coliseum Manual

Genie part number 1268770

---

### D-3

#### Perform Coupler Maintenance



Coupler specifications require that this procedure be performed annually.

Maintaining the coupler in good condition is essential to safe operation and good performance. Coupler failure could result in a machine tip-over during transport, and component damage may also result if problems are not discovered and repaired in a timely fashion.

- 1 Check coupler welds and mounting bolt torque. Torque the fasteners to 35 ft-lbs / 48 Nm.
  - ⊙ Result: 1.5 full threads of the locking bolt must be exposed beyond the lock nut after the adjustment.
- 2 Apply automotive grease to the coupler ball pocket.
- 3 Oil coupler pivot points using SAE 30 motor oil.

## Checklist E Procedures

### E-1

### Inspect the Cables and Cable Pulleys



Terex specifications require that this procedure be performed every two years.

Detection of damage to the cables or pulleys is essential for safe machine operation. An unsafe working condition exists if these components are damaged and do not operate smoothly. Regular inspection of this system allows the inspector to identify changes in the operating condition that may indicate damage.

- 1 Visually inspect the electric winch and cable pulleys for the following:
  - broken or damaged pulleys
  - unusual or excessive pulley wear
- ⊙ Result: A pulley is broken or damaged, or shows unusual or excessive pulley wear. The pulley must immediately be replaced.
- 2 Put on protective leather gloves and eye wear.
- 3 Fully unwind the cable from the winch.
- 4 Wearing leather gloves, run a hand up and down a length of the cable, inspecting the cable and components for the following:
  - frayed or broken wire strands
- ⊙ Result: In any given one-foot of cable length there are 4 or more broken wires on any 2 or more strands. The cable must immediately be replaced.

## Checklist E Procedures

- 5 Visually inspect the winch cable for the following:
- nicks (partial strand cut through)
  - kinks in the cable (permanent bends)
  - weld splatter
- ⊕ Result: Nicks, kinks in the cable or weld splatter are. The cable must immediately be replaced.
- 6 Visually inspect the winch cable for the following:
- crushed spot on the cable
- ⊕ Result: A crushed spot on the cable measuring 125% of the cable diameter or more is found OR there is a broken wire at the crush point. The cable must immediately be replaced.
- 7 Wind cable onto the winch, ensuring that the cable is correctly installed onto each of the pulleys.

If the mast cables need replacing, refer to Repair Procedure 1-1, How to Replace the Mast Lift Cables.

### E-2

## Perform Engine Maintenance



Engine specifications require that this procedure be performed every 2000 hours or bi-annually, whichever comes first.

- Replace coolant
- Replace radiator hoses and clamps
- Replace fuel hoses and clamps
- Replace air intake hose and clamps

Required maintenance procedures and additional engine information is available in the Kubota D1105-E and V1505-E Operator's Manual (Kubota 16683-89169 part number ) OR the Kohler KDW1003 Engine Owner's Manual (Kohler part number ED0053028440).

---

#### Kohler KDW1003 Engine Owner's Manual

Genie part number	1268769
-------------------	---------

---

#### Kubota D-1105 and V-1505 Operator's Manual

Genie part number	893020
-------------------	--------

---

## Checklist E Procedures

### E-3 Perform Engine Maintenance



Engine specifications require that this procedure be performed every 3000 hours.

- Inspect injection pump
- Inspect injection timing

Required maintenance procedures and additional engine information is available in the Kubota D1105-E and V1505-E Operator's Manual (Kubota 16683-89169 part number ) OR the Kohler KDW1003 Engine Owner's Manual (Kohler part number ED0053028440).

---

<b>Kohler KDW1003 Engine Owner's Manual</b>	
Genie part number	1268769

---

<b>Kubota D-1105 and V-1505 Operator's Manual</b>	
Genie part number	893020

---

### E-4 Perform Generator Maintenance



Generator specifications require that this procedure be performed every 10,000 hours.

Maintaining the generator in good condition is essential to safe operation and long service life. Regular replacement of the shaft bearing will extend the life of the generator.

- Replace the generator shaft bearing. Consult a trained Coliseum service professional.

---

<b>Coliseum Manual</b>	
Genie part number	1268770

---

## Checklist E Procedures

### E-5 Perform Generator Maintenance



Generator specifications require that this procedure be performed every 20,000 hours or 3 years, whichever comes first.

Maintaining the generator in good condition is essential to safe operation and long service life. Storing the generator in a harsh environment may require this procedure be performed more frequently. Allowing dirt and grease to build up on the generator may result in a generator which will run hotter, lose efficiency, and reduce the life of the generator.

- Inspect and clean the generator and windings for oil or dirt contamination.

---

#### Coliseum Manual

Genie part number 1268770

---

### E-6 Perform Generator Maintenance



Generator specifications require that this procedure be performed every 30,000 hours or 5 years, whichever comes first.

Maintaining the generator in good condition is essential to safe operation and long service life. Storing the generator in a harsh environment may require this procedure be performed more frequently. Allowing dirt and grease to build up on the generator may result in a generator which will run hotter, lose efficiency, and reduce the life of the generator. Regular replacement of the shaft bearing will extend the service life of the generator.

- Disassemble the generator, including rotor removal.
- Inspect and clean generator components including generator windings.
- Replace the generator shaft bearings. Consult a trained Coliseum service professional.

---

#### Coliseum Manual

Genie part number 1268770

---

## Repair Procedures



### Observe and Obey:

- Repair procedures shall be completed by a person trained and qualified on the repair of this machine.
- Immediately tag and remove from service a damaged or malfunctioning machine.
- Repair any machine damage or malfunction before operating the machine.

### Before Repairs Start:

- Read, understand and obey the safety rules and operating instructions in the appropriate operator's manual on your machine.
- Be sure that all necessary tools and parts are available and ready for use.
- Use only Terex approved replacement parts.
- Read each procedure completely and adhere to the instructions. Attempting shortcuts may produce hazardous conditions.

### Machine Configuration:

- Unless otherwise specified, perform each repair procedure with the machine in the following configuration:
  - Machine parked on a firm, level surface
  - Mast in the stowed position
  - Key switch in the off position with the key removed
  - The red Emergency Stop button in the off position on the electrical control box
  - Wheels chocked
  - Light switches in the off position
  - All external AC power supply disconnected from the machine

---

# Repair Procedures

## About This Section

Most of the procedures in this section should only be performed by trained service professional in a suitably equipped workshop. Select the appropriate repair procedure after troubleshooting the problem.

Perform disassembly procedures to the point where repairs can be completed. Then to re-assemble, perform the disassembly steps in reverse order.

## Symbols Legend



Safety alert symbol—used to alert personnel to potential personal injury hazards. Obey all safety messages that follow this symbol to avoid possible injury or death.

### **DANGER**

Indicates a imminently hazardous situation which, if not avoided, will result in death or serious injury.

### **WARNING**

Indicates a potentially hazardous situation which, if not avoided, could result in death or serious injury.

### **CAUTION**

Indicates a potentially hazardous situation which, if not avoided, may cause minor or moderate injury.

### **NOTICE**

Indicates a potentially hazardous situation which, if not avoided, may result in property damage.

- ⦿ Indicates that a specific result is expected after performing a series of steps.
- ⊗ Indicates that an incorrect result has occurred after performing a series of steps.



# Lighting

## 1-1 How to Remove a Lamp

**⚠ WARNING** Electrocutation/burn hazard. Contact with electrically charged circuits could result in death or serious injury. Remove all rings, watches and other jewelry.

**⚠ CAUTION** Burn hazard. Beware of hot lamp components. Contact with hot lamp components may result in severe burns.

- 1 Turn off all machine power.
- 2 Remove the light lens mounting fasteners and remove the lens.
- 3 Remove the spring securing the lamp to the lamp retainer.

**NOTICE** Component damage hazard. Contacting the lamp with bare skin can cause damage to the lamp. Do not allow bare skin contact with the lamps.

- 4 Wrap a clean cloth around the lamp and remove it from the socket.

Note: Be sure to wrap a clean cloth around the lamp when installing it into the lamp socket.

## 1-2 How to Check Line Voltage

Correct line voltage at the lamp socket is essential for proper operation of the lighting system.

**⚠ WARNING** Electrocutation/burn hazard. Contact with electrically charged circuits could result in death or serious injury. Remove all rings, watches and other jewelry.

- 1 Turn off all machine power.
- 2 Remove the cover from the lamp junction box.

Note: The junction box is located between the light housings at the top of the mast.

- 1 Locate the correct wiring for the lamp to be tested.
- 2 Connect a voltmeter to the lamp wires.
- 3 Start the engine.
- 4 Turn the appropriate circuit breaker light switch to the "ON" position.
- 5 Observe the voltage as the lamps warm up. Refer to the following chart.

Note: It can take up to 5 minutes for the lights to reach full intensity. If the lights are turned off and then turned back on while they are still warm, they may not light up again for 10 to 20 minutes.

Time	Line Voltage
Initial ignition	415V AC
30 seconds	412V AC
1 minute	413V AC
2 minutes	416V AC
5 minutes	246V AC
10 minutes	251V AC

Note: If voltage reading remains high during warm up, check for loose or broken wire connections or the lamp may be faulty.

Note: The voltage readings provided in the chart are averages, voltage on your machine may vary.

# Lighting

## 1-3 How to Check the Open Circuit Voltage

Correct line voltage at the lamp socket is essential for proper operation of the lighting system.

**⚠ WARNING** Electrocutation/burn hazard. Contact with electrically charged circuits could result in death or serious injury. Remove all rings, watches and other jewelry.

- 1 Turn off all machine power.
- 2 Locate the electrical cable of the lamp to be tested. Disconnect the cable from the junction box attached to the light bar.
- 3 Set a voltmeter to read 0 to 750V AC. Insert the leads of the voltmeter into pins A and B of the electrical connector socket at the junction box.

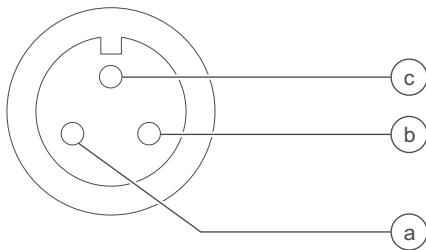

- 4 Start the engine.
- 5 Turn the appropriate circuit breaker light switch to the "ON" position and observe the reading on the voltmeter. Refer to the following chart.

---

<b>Open Circuit Voltage Specification</b>	375V AC to 465V AC
---	--------------------

---

Note: If there is no reading on the meter. Repair or replace the capacitor, ballast or wiring.

# Mast

## 2-1 How to Remove the Mast Assembly

**▲ WARNING** Bodily injury hazard. The procedures in this section require specific repair skills, lifting equipment and a suitable workshop. Attempting this procedure without these skills and tools could result in death or serious injury and significant component damage. Dealer service is required.

**▲ CAUTION** Bodily injury hazard. Cables can fray. Always wear adequate hand protection when handling the cable.

- 1 Tag and remove the light heads from the mast.
- 2 Remove the junction box from the light bar. Remove and retain the coil cord clamp and hardware from the base section of the mast. Lay the coil cord, junction box and lamp heads to the side.
- 3 Remove the fasteners securing the mast base to the chassis.
- 4 Attach a lifting strap from an overhead crane to the mast base beneath the rotating section and T-bolt. Remove the mast from the machine.

## 2-2 How to Disassemble the Mast Assembly

- 1 Remove the mast assembly. See 1-1, How to Remove the Mast Assembly.
- 2 Remove the T-bolt from the mast base assembly.
- 3 Remove the nut from the bottom of the mast base. Remove the mast base assembly from the 4" inch mast section.

**▲ CAUTION** Bodily injury hazard. Cables can fray. Always wear adequate hand protection when handling the cable.

**NOTICE** Component damage hazard. Cables can be damaged if they are kinked or pinched.

- 4 Remove the light bar assembly and hardware from the 1.5 inch / 3.8 cm mast section and set aside. Remove the 1.5 inch / 3.8 cm mast section from the 2 inch / 5 cm mast section. Disconnect the cable from the 2 inch / 5 cm mast section by removing the cable retention pin.
- 5 Working at the top of the 3 inch / 7.5 cm mast section, use a drill to remove the rivets securing the wear pads in position.
- 6 Remove the 2 inch / 5 cm mast section from the 3 inch / 7.5 cm mast section. Disconnect the cable from the 3 inch / 7.5 cm mast section by removing the cable retention pin.

---

## Mast

- 7 Working at the top of the 4 inch / 10 cm mast section, use a drill to remove the rivets securing the wear pads in position.
- 8 Remove the 3 inch / 7.5 cm mast section from the 4 inch / 10 cm mast section. Disconnect the cable from the 4 inch / 10 mast section by removing the cable retention pin.
- 9 Remove the clevis pin and sheave from the 2 inch / 5 cm mast section.
- 10 Remove the clevis pin and sheave from the 3 inch / 7.5 cm mast section.
- 11 Remove the clevis pin and sheave from the 4 inch / 10 cm mast section.

Note: For ease of assembly, note the location where each wear pad is removed.

Note: To ensure that the mast extends properly after assembly, carefully measure the cable to confirm that the new cable is the same length as the old one.

Note: During assembly, carefully install the mast cable. Refer to the illustration on the following page for cable routing.

# Mast

## 2-3 How to Replace the Mast Lift Cables

See 2-2, How to Disassemble the Mast Assembly.

Note: Refer to the illustration below for cable routing detail.

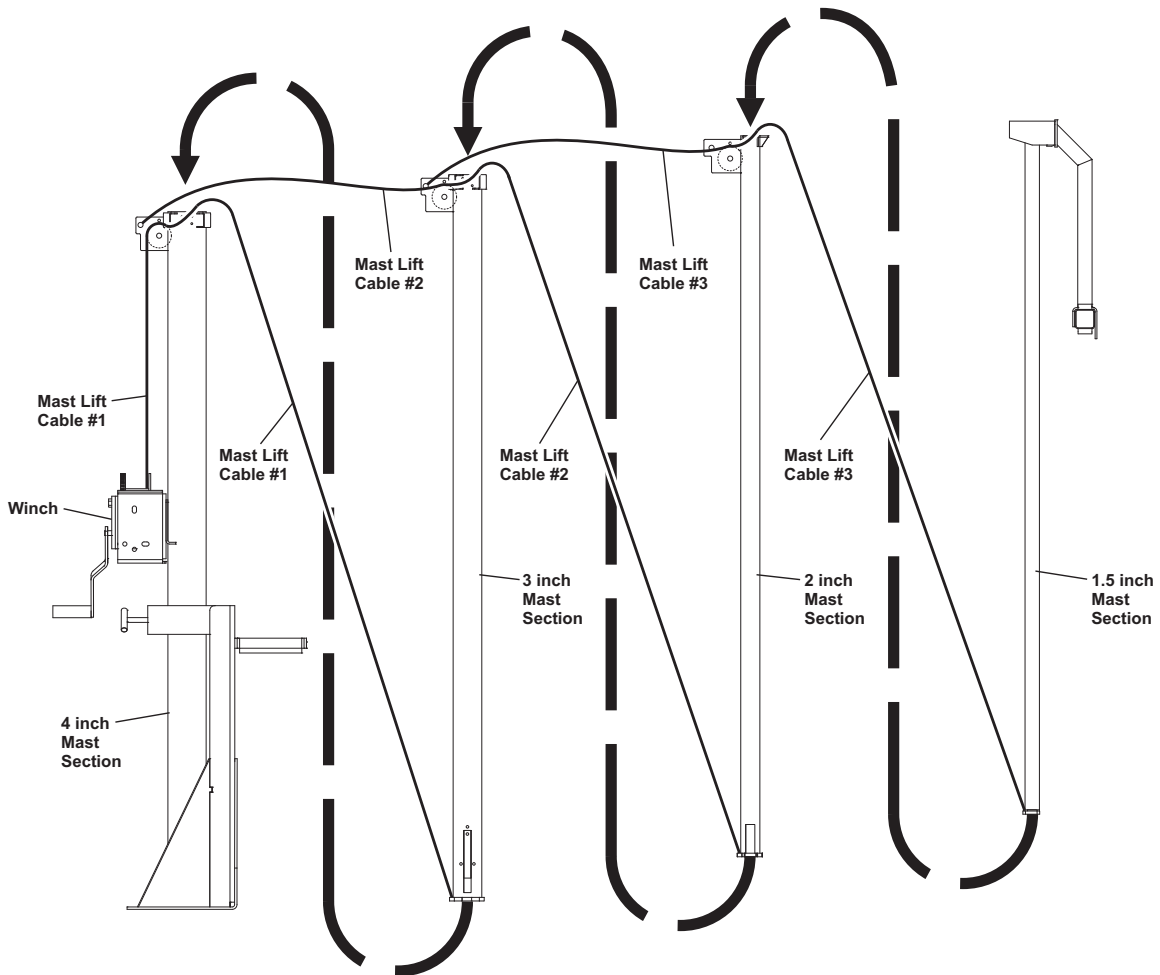

---

# Mast

## 2-4 How to Remove the Manual Winch

- 1 Turn the handle of the mast pivot winch and fully loosen the mast pivot cable. Remove the handle from the winch.
- 2 Open the cabinet doors and locate the winch. Remove the fasteners securing the handle to the winch, and remove the handle.
- 3 Remove the cable retaining fastener securing the cable to the winch drum. Unwind the cable from the winch drum.

**▲ CAUTION** Bodily injury hazard. Cables can fray. Always wear adequate hand protection when handling the cable.

- 4 Remove the winch from the machine.

# Mast

## 2-5 How to Remove the Electric Winch

- 1 Lower the mast assembly to the stowed position.
- 2 Remove the fasteners and winch covers from the 4 inch / 10 cm mast assembly and set aside. Refer to the illustration below.
- 3 On the electric winch, turn the yellow cap to the free spool position.

- 4 Pull the cable to unwind it from the winch drum.

- 5 Loosen the set screw securing the cable.

Note: Before removing the cable from the winch drum, make note of the cable routing. The cable must be routed the same way when installing the electric winch.

- 6 Remove the fasteners securing the electric winch to the 4 inch / 10 cm mast assembly.

### CAUTION

Bodily injury hazard. Cables can fray. Always wear adequate hand protection when handling the cable.

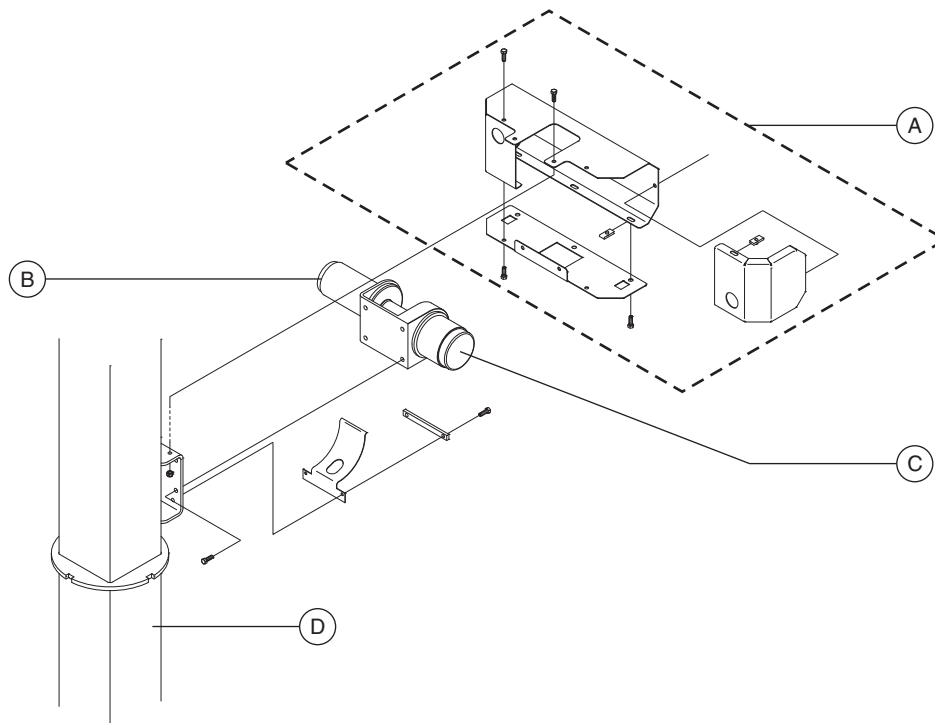

- a winch covers
- b electric winch
- c engaged/free spool lock
- d 4 inch / 10 cm mast assembly

# Kohler KDW1003 Engine

## 3-1 Timing Adjustment-Kohler Engines

Complete information to perform this procedure is available in the Kohler KDW 702 - 1003 - 1404 Workshop Manual (Kohler part number: ED0053029340).

---

**Kohler KDW 702 - 1003 - 1404 Workshop Manual**

---

Genie part number	1268828
-------------------	---------

---

## 3-2 Glow Plugs-Kohler Engines

- 1 Disconnect the wiring and buss bar from the glow plugs.
  - 2 Connect the leads from an ohmmeter between each glow plug terminal and ground.
- ⊕ Result: The resistance should be approximately 1 ohm.
  - ⊗ Result: The resistance is 0 ohm or greater than 1 ohm. The glow plug is faulty.

## 3-3 Coolant Temperature and Oil Pressure Switches-Kohler Engines

The engine coolant temperature switch is a normally open switch. The switch contacts close at approximately 235°F / 113°C. If the coolant temperature rises above the switch point, the switch contacts close and the engine will shut off to prevent damage. The engine will not start until the temperature drops below the switch point. Additionally a low coolant level can cause the coolant temperature switch to not work properly. Make sure that the coolant system is at proper level.

The engine oil pressure switch is a normally closed switch. The switch contacts open at approximately 6.5 psi / 0.45 bar. If the oil pressure drops below the switch point, the contacts open and the engine will shut off to prevent damage.



# Kubota D1105-E Engine

## 4-1 Timing Adjustment-Kubota Engines

Complete information to perform this procedure is available in the Kubota 05 Series Workshop Manual (Kubota part number: 97897-02432).

---

### Kubota 05 Series Workshop Manual

Genie part number	31742
-------------------	-------

---

## 4-2 Glow Plugs-Kubota Engines

- 1 Disconnect the wiring and buss bar from the glow plugs.
  - 2 Connect the leads from an ohmmeter between each glow plug terminal and ground.
- ⊕ Result: The resistance should be approximately 1 ohm.
  - ⊗ Result: The resistance is 0 ohm or greater than 1 ohm. The glow plug is faulty.

## 4-3 Coolant Temperature and Oil Pressure Switches-Kubota Engines

The engine coolant temperature switch is a normally open switch. The switch contacts close at approximately 225°F / 107°C. If the coolant temperature rises above the switch point, the switch contacts close and the engine will shut off to prevent damage. The engine will not start until the temperature drops below the switch point. Additionally a low coolant level can cause the coolant temperature switch to not work properly. Make sure that the coolant system is at proper level.

The engine oil pressure switch is a normally closed switch. The switch contacts open at approximately 7 psi / 0.48 bar. If the oil pressure drops below the switch point, the contacts open and the engine will shut off to prevent damage.

# Generator

## 5-1 Generator

### **⚠ DANGER**

High voltage. Exposure to electrical wires or electrical current will result in death or serious injury. Turn off all power when not needed for testing. Use extreme caution when working with high voltage electrical components.

### **⚠ DANGER**

Electrocution/burn hazard. Attempting to service the machine before the capacitor is fully discharged will result in death or serious injury.

**Note:** Be sure the engine has been turned off for at least 15 minutes before servicing the machine. Use a voltmeter to confirm there is no residual voltage in the capacitor.

- 1 Deploy the outriggers and level the machine.
- 2 Disconnect the rear fairing wiring harnesses located along side the roadside lift bar.
- 3 Disconnect the gas struts on the rear fairing assembly from the lift bar.
- 4 Remove the screws from the hinges attaching the rear fairing assembly to the lift bar.
- 5 Carefully lift the rear fairing assembly off the unit and set aside.
- 6 Remove the left side cabinet weldment and fender.

- 7 Remove the screws and washers securing the generator pedestal to the chassis.

### **⚠ CAUTION**

Burn hazard. Beware of hot engine components. Contact with hot engine components may result in severe burns.

- 8 Open the control box by removing the two upper screws of the control panel. Tilt the control panel forward in order to access the generator wiring located on the inside of the control box.
- 9 Using an insulated conductor or a screwdriver with an insulated handle, discharge the capacitor by shorting across the capacitor terminals.

### **⚠ DANGER**

High voltage. Exposure to electrical wires or electrical current will result in death or serious injury. Use extreme caution when working with high voltage electrical components.

- 10 Tag and disconnect all external wires from the generator.
- 11 Support the generator using the lifting eye.
- 12 Remove the fasteners securing the generator to the engine bellhousing.
- 13 Pull the generator away from the engine just enough to reach the fasteners securing the generator rotor to the engine flywheel. Remove the fasteners.
- 14 Remove the generator from the machine.

### **⚠ CAUTION**

Crushing hazard. The generator may become unbalanced and fall if not properly supported when removed from the machine.

# Generator

## 5-2 How to Check a Generator Capacitor

### **⚠ DANGER**

High voltage. Exposure to electrical wires or electrical current will result in death or serious injury. Turn off all power when not needed for testing. Use extreme caution when working with high voltage electrical components.

### **⚠ DANGER**

Electrocution/burn hazard. Attempting to service the machine before the capacitor is fully discharged will result in death or serious injury.

Note: Be sure the engine has been turned off for at least 15 minutes before servicing the machine. Use a voltmeter to confirm there is no residual voltage in the capacitor.

- 1 Open the control box by removing the two upper screws of the control panel. Tilt the control panel forward in order to access the generator wiring located on the inside of the control box.
- 2 Using an insulated conductor or a screwdriver with an insulated handle, discharge the capacitor by shorting across the capacitor terminals.

### **⚠ DANGER**

High voltage. Exposure to electrical wires or electrical current will result in death or serious injury. Use extreme caution when working with high voltage electrical components.

- 3 Tag and disconnect the wires attached to the capacitor.

- 4 With an ohmmeter set to its highest resistance scale, connect the ohmmeter leads to the capacitor terminals and observe the reading on the meter. Then, reverse the connections and observe the reading on the meter.
  - ⦿ Result: The meter indicates a very low resistance which then gradually increases AND a very high resistance which then gradually decreases. The capacitor is working.
  - ⊗ Result: The meter indicates a very high resistance which does not decrease. The capacitor is faulty and should be replaced.
  - ⊗ Result: The meter indicates a very low resistance which does not increase. The capacitor is faulty and should be replaced.

## 5-3 How to Check a Generator Diode

### **⚠ DANGER**

High voltage. Exposure to electrical wires or electrical current will result in death or serious injury. Turn off all power when not needed for testing. Use extreme caution when working with high voltage electrical components.

### **⚠ DANGER**

Electrocution/burn hazard. Attempting to service the machine before the capacitor is fully discharged will result in death or serious injury.

Note: Be sure the engine has been turned off for at least 15 minutes before servicing the machine. Use a voltmeter to confirm there is no residual voltage in the capacitor.

- 1 Remove the fasteners securing the end cover/bearing housing to the generator. Remove the cover.

---

## Generator

- 2 Locate the diode at the end of the generator.
- 3 Tag and disconnect the positive wire lead from the diode.
- 4 With a multimeter set to test diodes, connect one multimeter lead to the diode terminal and the other multimeter lead to the 'Q' lead terminal of the generator. Note the results.

Note: Refer to the instructions which are provided for your multimeter to ensure the diode is accurately tested.

- 5 Reverse the multimeter lead connections. Note the results.
- ⊕ Result: The two readings are at a ratio of 3000:1 or higher. The diode is good.
  - ⊗ Result: The two readings are at a ratio of less than 3000:1. The diode is faulty and should be replaced.

Note: Before installing a new diode, clean the surface of the exciter rotor core, and run a bead of a thermal-electrical compound around the base of the diode (the threads of the diode should not be coated). Torque to 20 to 30 in-lbs / 2.2 to 3.4 Nm.

## Light Ballast

### 6-1 Ground Controls

The timer is used to automatically start the engine and turn on the lights at a preset time.

- 1 Move the engine start switch to timed start.
  - 2 On the timer, move the mode switch (upper left switch) to AUTO and the set switch (upper right switch) to RUN.
  - 3 Using the tip of a pencil or pen, press the Reset button (R). A blinking display will show 0:00 for the time and an arrow under the day 7 (for Sunday).
  - 4 Move the set switch to the left (clock icon) to set the present day and time.
  - 5 A default time of AM 12:00 will appear on the display screen.
  - 6 Press the day button (1..7) repeatedly until the arrow points to the actual day of the week.
  - 7 Press the hour button (h) repeatedly until the actual hour of the day is displayed.
  - 8 Press the minute button (m) repeatedly until the minute of the present hour is displayed.
  - 9 Move the Set switch to the program position (P) to set the desired stop and start time. A default time of AM 12:00 will appear. A small 1 will appear to the right of the time with a lamp symbol above it.
  - 10 Use the day, hour and minute buttons to set the timer to the desired start day and time.
  - 11 Press the program button (P) to set the timer for the desired shut-off time. AM 12:00 will appear in the display with a small 2 to the right.
- Note: The lamp symbol will not appear above the 2.
- 12 Use the day, hour and minute buttons to set the timer to the desired shut-off day and time.
  - 13 Move the set switch to RUN.

## Light Ballast

### 6-2 Light Ballast

**⚠ DANGER** High voltage. Exposure to electrical wires or electrical current will result in death or serious injury. Turn off all power when not needed for testing. Use extreme caution when working with high voltage electrical components.

**⚠ DANGER** Electrocutation/burn hazard. Attempting to service the machine before the capacitor is fully discharged will result in death or serious injury.

**Note:** Be sure the engine has been turned off for at least 15 minutes before servicing the machine. Use a voltmeter to confirm there is no residual voltage in the capacitor.

**Note:** This procedure is only for the capacitors which are attached to the lighting ballasts. To test a generator capacitor, see 5-2, How to Check a Generator Capacitor.

- 1 Open the control box by removing the two upper screws of the control panel. Tilt the control panel forward to access the ballast capacitors located on the inside of the control box.
- 2 Choose a capacitor. Remove the plastic terminal cover and disconnect the wire harness connector from the capacitor.
- 3 Using an insulated conductor or a screwdriver with an insulated handle, discharge the capacitor by shorting across the capacitor terminals.

**Note:** Refer to the instructions which are provided for your multimeter to ensure the diode is accurately tested.

**⚠ DANGER** High voltage. Exposure to electrical wires or electrical current will result in death or serious injury. Turn off all power when not needed for testing. Use extreme caution when working with high voltage electrical components.

- 4 With an ohmmeter set to its highest resistance scale, connect the ohmmeter leads to the capacitor terminals and observe the reading on the meter. Then, reverse the connections and observe the reading on the meter.
  - ⊕ **Result:** The meter indicates a resistance which then gradually decreases. The capacitor is working.
  - ⊗ **Result:** The meter indicates a very high resistance which does not decrease. The capacitor is faulty and should be replaced.
  - ⊗ **Result:** The meter indicates a very low resistance which does not increase. The capacitor is faulty and should be replaced.
- 5 Repeat the above procedure for each ballast capacitor.

#### Probable causes of capacitor failure:

- Normal end-of-life failure.
- Overheated due to light fixture heat or high ambient temperature.
- Incorrect capacitor voltage rating.
- Capacitor becomes loose in ballast box.

# Fuel Tank

## 7-1 Fuel Tank

- 1 Remove the fuel filler cap from the tank. Using an approved hand-operated pump, drain the fuel tank into a container of suitable capacity. Refer to Section 2, Specifications.

**⚠ DANGER** Explosion and fire hazard. Engine fuels are combustible. Perform this procedure in an open, well-ventilated area away from heaters, sparks, flames and lighted tobacco. Always have an approved fire extinguisher within easy reach.

**⚠ DANGER** Explosion and fire hazard. When transferring fuel, connect a grounding wire between the machine and pump or container.

**NOTICE** Be sure to only use a hand operated pump suitable for use with diesel fuel.damage hazard. Be sure not to cut the power to the platform wiring.

### Remove the rear fairing assembly:

- 2 Deploy the outriggers and level the machine.
- 3 Disconnect the rear fairing wiring harnesses located along side the roadside lift bar.
- 4 Disconnect the gas struts on the rear fairing assembly from the lift bar.
- 5 Remove the screws from the hinges attaching the rear fairing assembly to the lift bar.
- 6 Carefully lift the rear fairing assembly off the unit and set aside.

### Remove the front fairing assembly:

- 7 Remove the fasteners securing the front fairing assembly to the chassis.
- 8 Carefully lift the front fairing assembly off the chassis and set aside.

### Remove the lift bar assembly:

- 9 Remove the fasteners securing the lift bar assembly to the chassis.
- 10 Remove the fasteners securing the lift structure cross brace to the light tower mast.
- 11 Carefully remove the lift bar assembly off the chassis and set aside.

### Remove the fuel tank assembly:

- 12 Tag, disconnect and plug the fuel hoses from the fuel tank.
- 13 Carefully remove the fuel tank assembly from the chassis and set aside.

**NOTICE** Component damage hazard. The fuel tank is plastic and may become damaged if allowed to fall.

- 14 Clean up any fuel that may have spilled.

Note: Clean the fuel tank and inspect for cracks and other damage before installing it onto the machine.

## Diagnostics



### Observe and Obey:

- ☑ Troubleshooting and repair procedures shall be completed by a person trained and qualified on the repair of this machine
- ☑ Immediately tag and remove from service a damaged or malfunctioning machine.
- ☑ Repair any machine damage or malfunction before operating the machine.
- ☑ Unless otherwise specified, perform each procedure with the machine in the following configuration:
  - Machine parked on a firm, level surface
  - Mast in the stowed position
  - Key switch in the off position with the key removed
  - The red Emergency Stop button in the off position on the electrical control box
  - Wheels chocked
  - Light switches in the off position
  - All external AC power supply disconnected from the machine

### Before Troubleshooting:

- ☑ Read, understand and obey the safety rules and operating instructions in the appropriate operator's manual on your machine.
- ☑ Be sure that all necessary tools and test equipment are available and ready for use.
- ☑ Read each appropriate fault code thoroughly. Attempting short cuts may produce hazardous conditions.
- ☑ Be aware of the following hazards and follow generally accepted safe workshop practices.

#### **⚠ WARNING**

Electrocution/burn hazard. Contact with electrically charged circuits could result in death or serious injury. Remove all rings, watches and other jewelry.

#### **⚠ DANGER**

High voltage. Exposure to electrical wires or electrical current will result in death or serious injury. Turn off all power when not needed for testing. Use extreme caution when working with high voltage electrical components.

#### **⚠ CAUTION**

Burn hazard. Beware of hot engine components. Contact with hot engine components may cause severe burns. Use caution when working around lamps or a hot engine.



## Diagnosics

Problem	Possible Cause	Solution
Mast will not rise to the operating position	Faulty cable or pulley	Inspect and repair as needed.
	Faulty winch	Inspect and repair as needed.
Engine will not turn over	No power	Inspect and repair battery cables and connections as needed. Inspect and charge or replace battery as needed. Inspect and replace fuse.
	Faulty starter	Inspect and repair as needed
	Faulty starter switch	Inspect and repair switch and/or switch wiring as needed
Engine overheats	Low coolant level	Top off radiator and coolant overflow tank with correct coolant mixture per engine operator's manual.
	Radiator blocked	Clear the radiator fins.
	Radiator or cooling system clogged or corroded	Inspect and repair as needed.
	Fan or radiator cap faulty	Inspect and repair as needed.
	Thermostat faulty	Inspect and repair as needed.
	Head gasket faulty	Inspect and repair as needed.
	Fan belt is loose	Tighten or replace fan belt.
	Unsuitable fuel used	Drain fuel system and replace with specified fuel.
Engine runs but produces a dense smoke	Crankcase oil level is too high	Drain oil to the proper level.
	Low compression	Inspect for broken/seized piston rings or inspect valve clearance.
	Injector nozzle faulty	Replace injector.
	Combustion incomplete due to faulty timing, poor valve adjustment or poor compression	Inspect and repair as needed.

## Diagnostics

Problem	Possible Cause	Solution
Engine runs rough	Air or contaminated fuel in fuel system	Inspect and repair as needed.
	Clogged or leaking fuel system	Replace fuel lines, tighten all connections, inspect the fuel pickup tube and inspect the fuel filter.
	Clogged exhaust system	Inspect and repair as needed.
	Clogged air filter	Inspect and repair or replace as needed.
	Clogged or stuck fuel injectors	Inspect and repair as needed.
	Faulty governor or fuel pump	Inspect and repair as needed.
Engine turns over but will not start or is difficult to start	Empty fuel tank	Add fuel to tank.
	Leaking or pinched fuel lines	Inspect and repair as needed.
	Clogged fuel filter	Replace filter.
	Air or water mixed in fuel	Air: Tighten fuel lines and vent fuel system air at injection pump. Water: Drain fuel and replace filter; inspect and clean or replace injector as needed.
	Fuel injection nozzle clogged	Inspect and repair as needed.
	Fuel injection pump faulty	Inspect and repair as needed.
	Fuel solenoid valve faulty	Inspect and repair as needed.
	Faulty glow plug	Inspect and repair as needed.
	Faulty relay or wiring connection in control box	Inspect and repair as needed.
	Battery is discharged or low	Charge or replace battery.
	Air cleaner is dirty	Clean or replace more frequently.

## Diagnosics

Problem	Possible Cause	Solution
Engine battery quickly discharged	Battery electrolyte low	Add distilled water and charge.
	Fan belt slips	Inspect and repair as needed.
	Wiring loose or disconnected	Inspect and repair as needed.
	Faulty alternator, rectifier or diode	Inspect and repair as needed.
	Faulty battery	Replace battery.
Engine runs but battery voltage is low	Faulty alternator	Inspect and repair as needed.
Engine runs but lights will not operate	Circuit breaker has tripped	Reset circuit breaker.
	Loose wiring connections	Inspect and repair as needed.
	Faulty generator	Inspect and repair as needed.
Lamp light output low	Dirty light fixture	Clean light fixture.
Light heads are flashing on-off	Batteries low	Charge batteries.
	Short in power supply cable	Inspect and repair as needed.
	Power supply cable connector faulty	Inspect and repair as needed.
Light head will not illuminate	End of life	Replace lamp or light head.
	Short in power supply cable	Inspect and repair as needed.
	Power supply cable connector faulty or poor connection	Inspect and repair as needed.
Unusual noise from the generator	Generator has a faulty bearing or faulty fan blade	Inspect and repair as needed.

## Diagnosics

Problem	Possible Cause	Solution
Generator produces full voltage at no load or voltage drops at full load	Loose or broken lead wires	Inspect lead wires and connections for broken wires and loose connections.
	Rotor open or shorted	Measure resistance between leads..
	Stator grounded or shorted	Contact the Genie Service Department.
Generator voltage too high	High engine speed	Adjust the rpm Refer to Section 2, Specifications
Generator produces no voltage at no load or at full load	Faulty surge suppressor	Disconnect suppressor from circuit. If there is an obvious increase in voltage, replace the suppressor.
	Faulty capacitor	Replace capacitor.
	Loss of residual magnetism	Flash the rotor.
	Open winding	Replace the generator.
Generator will not hold voltage (loss of residual magnetism)	Machine has been unused for a significant length of time	Flash the rotor.
	Rotor shorting out when the unit gets hot	Inspect rotor windings for broken and/or burned wires.
	Pinched leads	Inspect and repair as needed.
	Faulty capacitor	Replace the capacitor.
	Faulty diode	Replace the diode.
	Faulty surge suppressor	Replace the surge suppressor.

## Diagnosics

Problem	Possible Cause	Solution
Generator voltage spikes	Incorrect engine adjustment, fuel line or faulty fuel	Change fuel filter and check engine speed.
	Loose connection	Inspect all connections and repair as needed.
	Faulty ground connection	Inspect all ground connections and repair as needed.
	Load induced	Filter load.
Generator voltage low	Loss of residual magnetism	Flash the rotor.
	Low engine speed	Adjust idle. See Repair Section.
	Faulty capacitor	Replace the capacitor.
	Faulty diode	Replace the diode.

# Schematics



## Observe and Obey:

- Troubleshooting and repair procedures shall be completed by a person trained and qualified on the repair of this machine
- Immediately tag and remove from service a damaged or malfunctioning machine.
- Repair any machine damage or malfunction before operating the machine.

## Before Troubleshooting:

- Read, understand and obey the safety rules and operating instructions in the appropriate operator's manual on your machine.
- Be sure that all necessary tools and test equipment are available and ready for use.

## About This Section

There are two groups of schematics in this section.

### Electrical Schematics

- ⚠ WARNING** Electrocutation/burn hazard. Contact with electrically charged circuits could result in death or serious injury. Remove all rings, watches and other jewelry.

### Hydraulic Schematics

- ⚠ WARNING** Bodily injury hazard. Spraying hydraulic oil can penetrate and burn skin. Loosen hydraulic connections very slowly to allow the oil pressure to dissipate gradually. Do not allow oil to squirt or spray.

---

## Wire Color Legend

### Wire Color Legend

BL	Blue
BK	Black
BR	Brown
GR	Green
OR	Orange
VI	Violet
RD	Red
WH	White
YL	Yellow
OR/BK	Orange/Black
WH/BK	White/Black
WH/RD	White/Red
GR/YL	Green/Yellow
RD/BK	Red/Black
YL/RD	Yellow/Red
BL/WH	Blue/White

---

# Wire Color Legend

This page intentionally left blank.



## RL4 Control Box AC Voltage Wiring - Standard



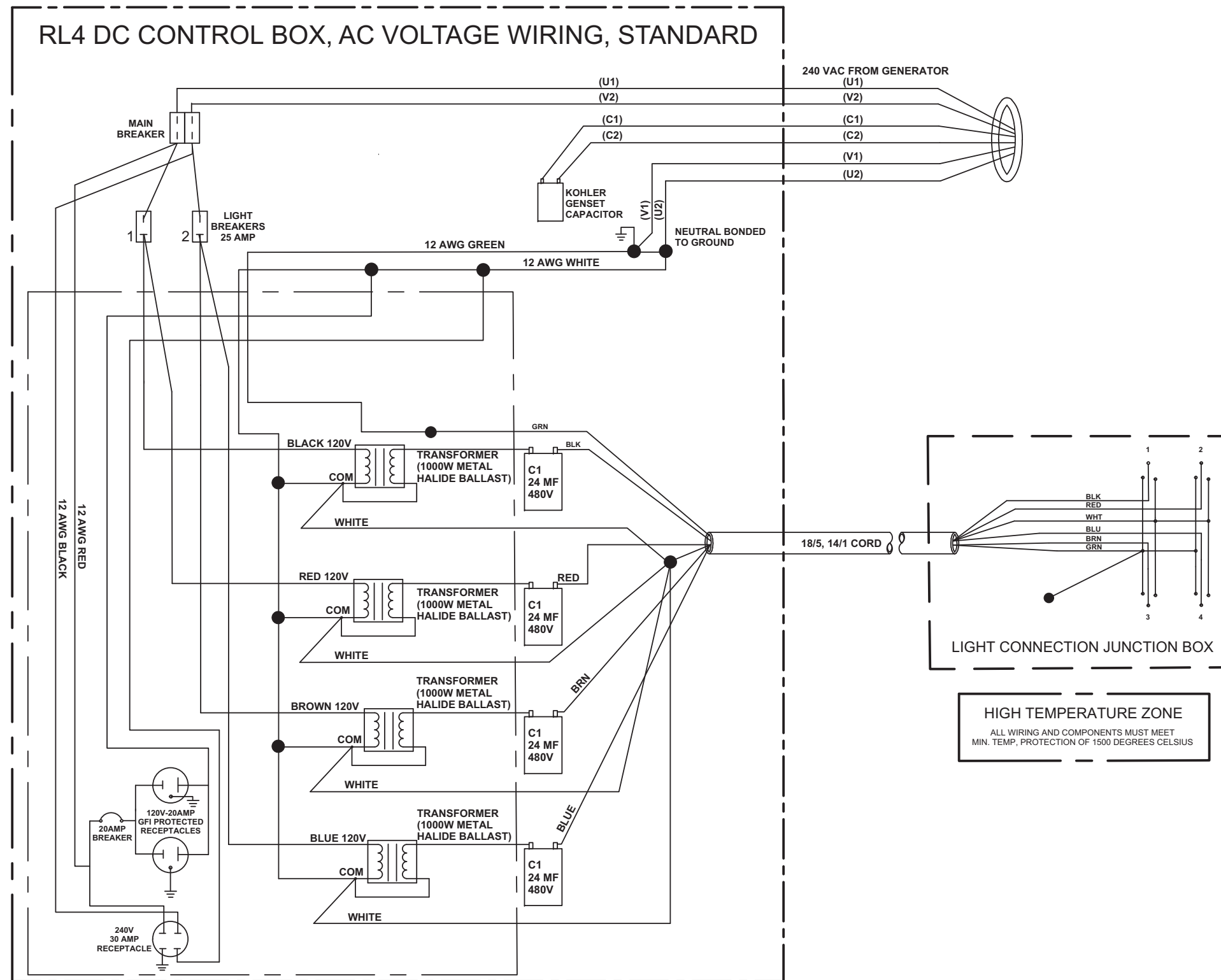

**RL4 Control Box AC Voltage Wiring - Autostart**



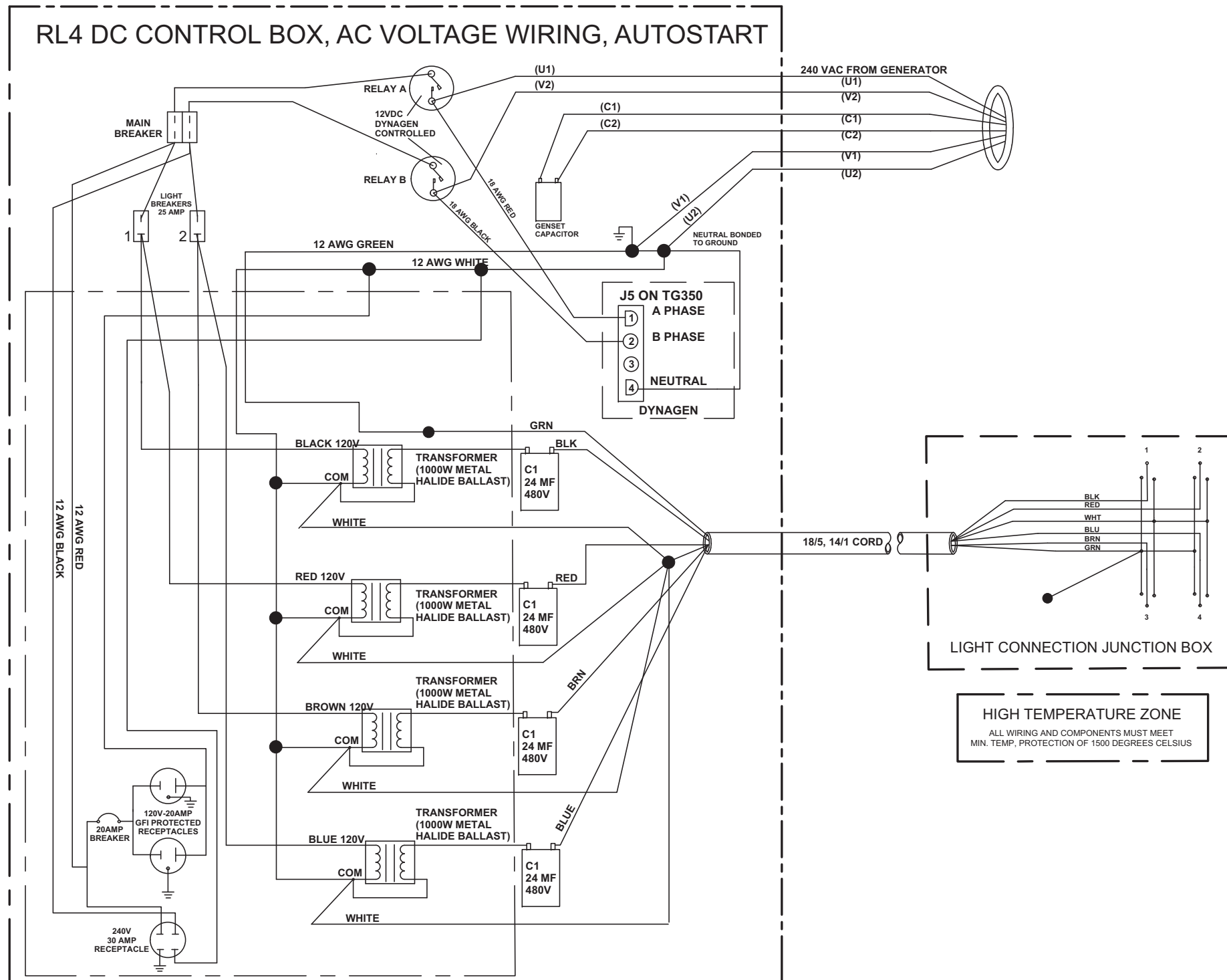

## RL4 DC Control Box Wiring - Standard



# RL4 DC CONTROL BOX, STANDARD

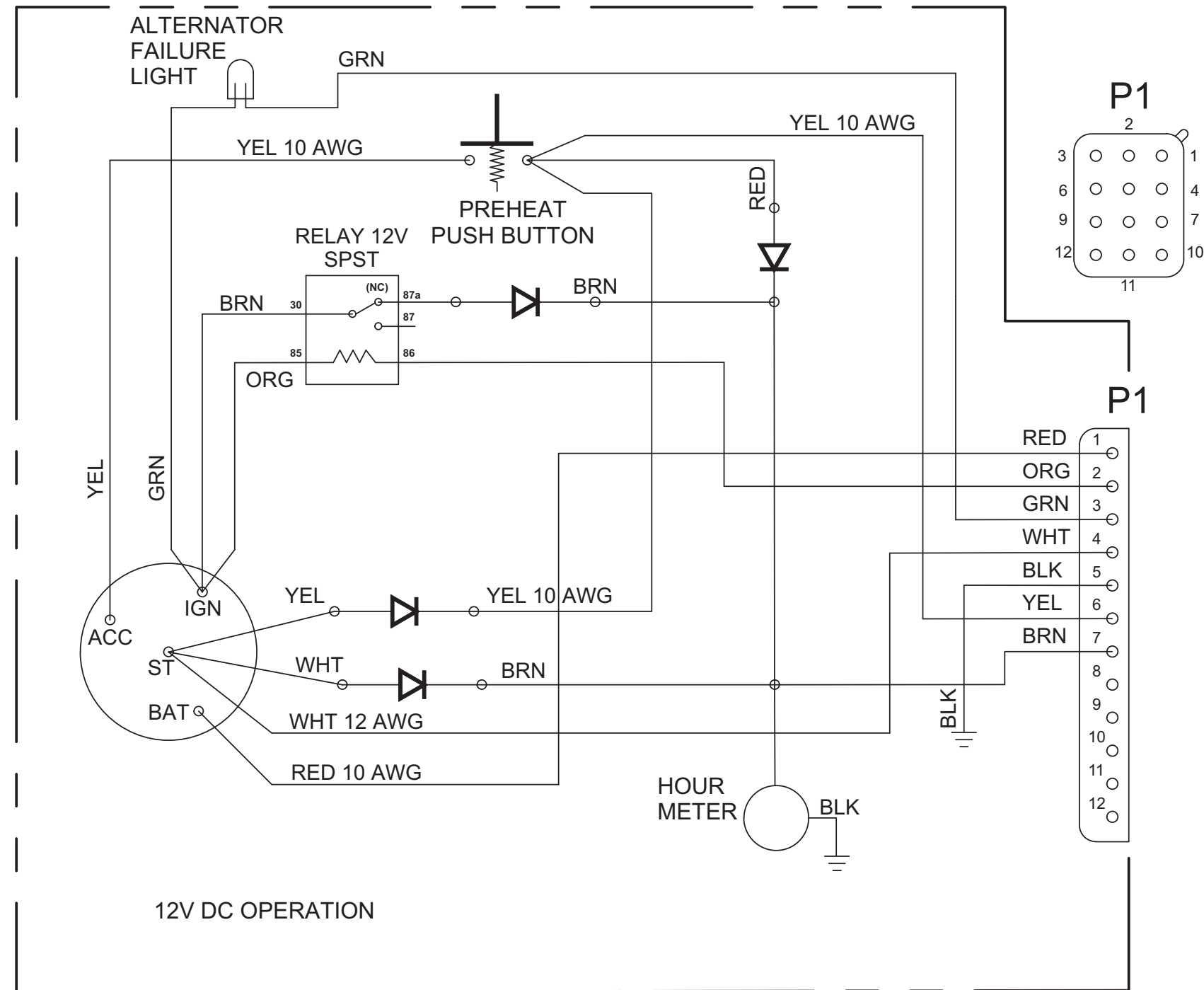

## RL4 DC Control Box Wiring - DynaGen



**RL4 WITH DYNAGEN TG350 AUTOSTART  
12V DC OPERATION**

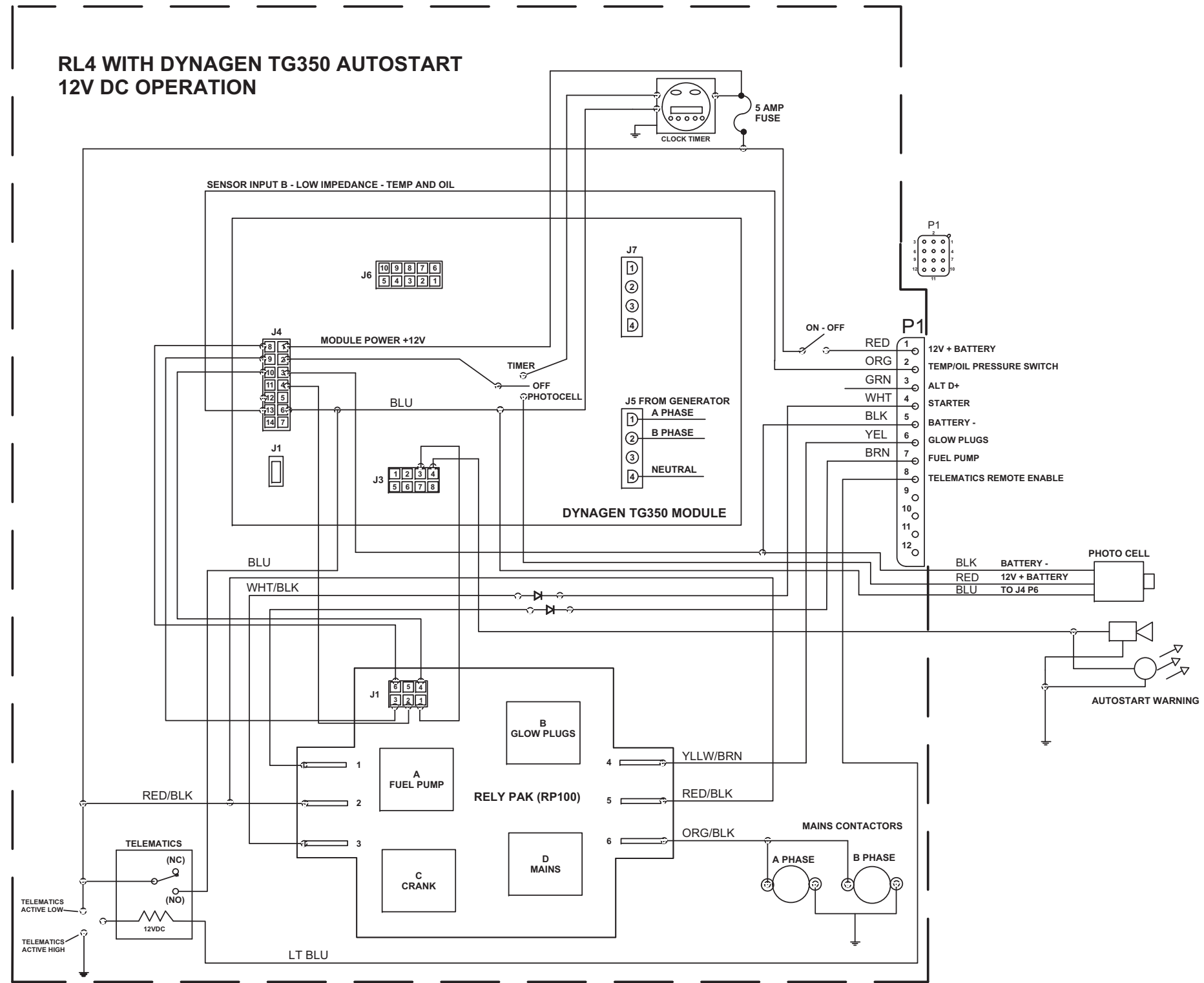



## RL4 DC Engine Components - Kohler



# RL4 DC ENGINE COMPONENTS (KOHLER)

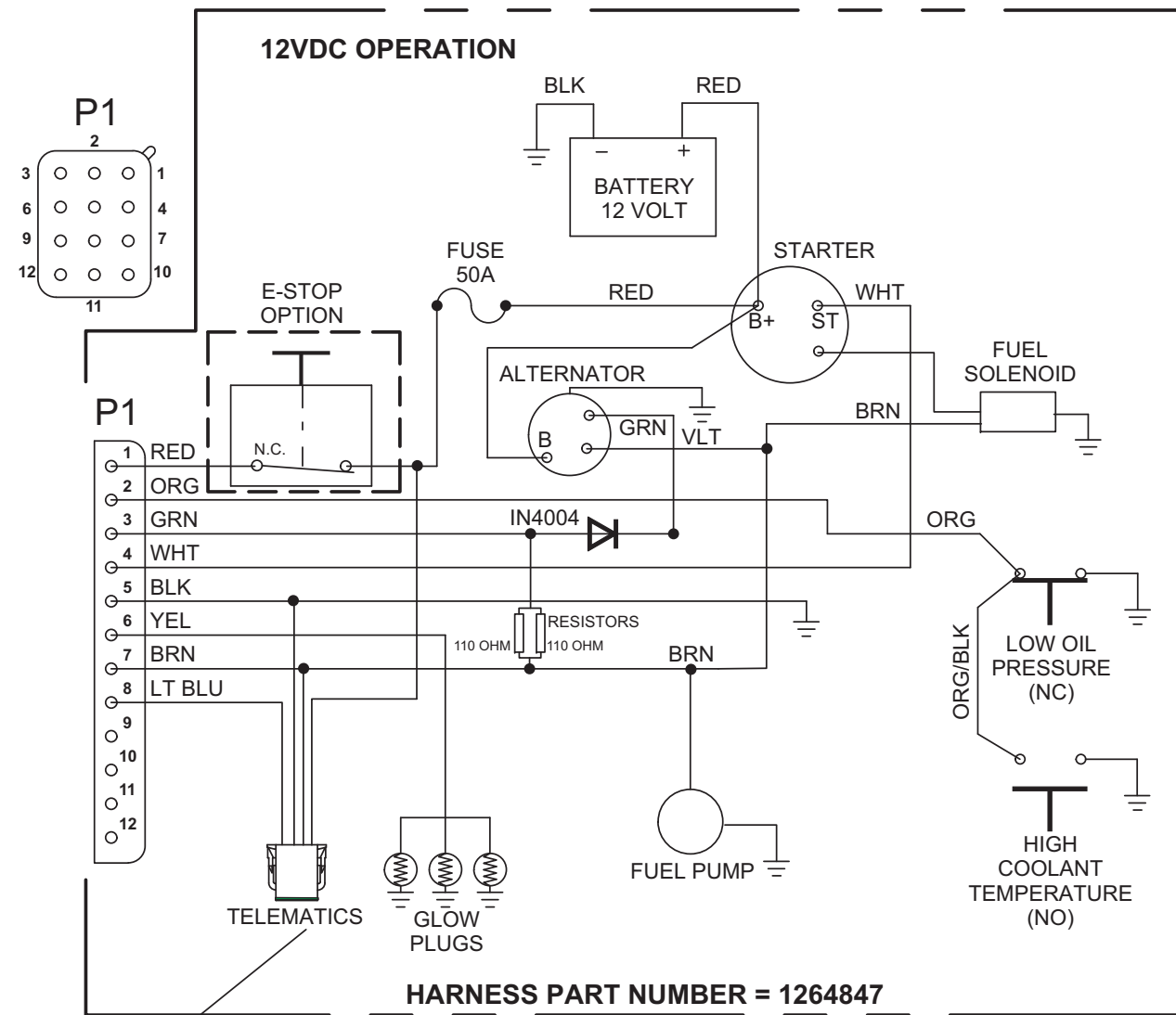

TELEMATICS		
PIN#	CKT#	COLOR
1	TEL BAT	RD
2	TEL GND	BK
3	TEL SIG	BRN
4	PLUG	-
5	PLUG	-
6	REMOTE ENABLE	LT BLU
7	PLUG	-
8	PLUG	-

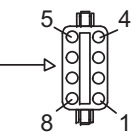

**RL4 DC Engine Components - Kubota**



# RL4 DC ENGINE COMPONENTS (KUBOTA)

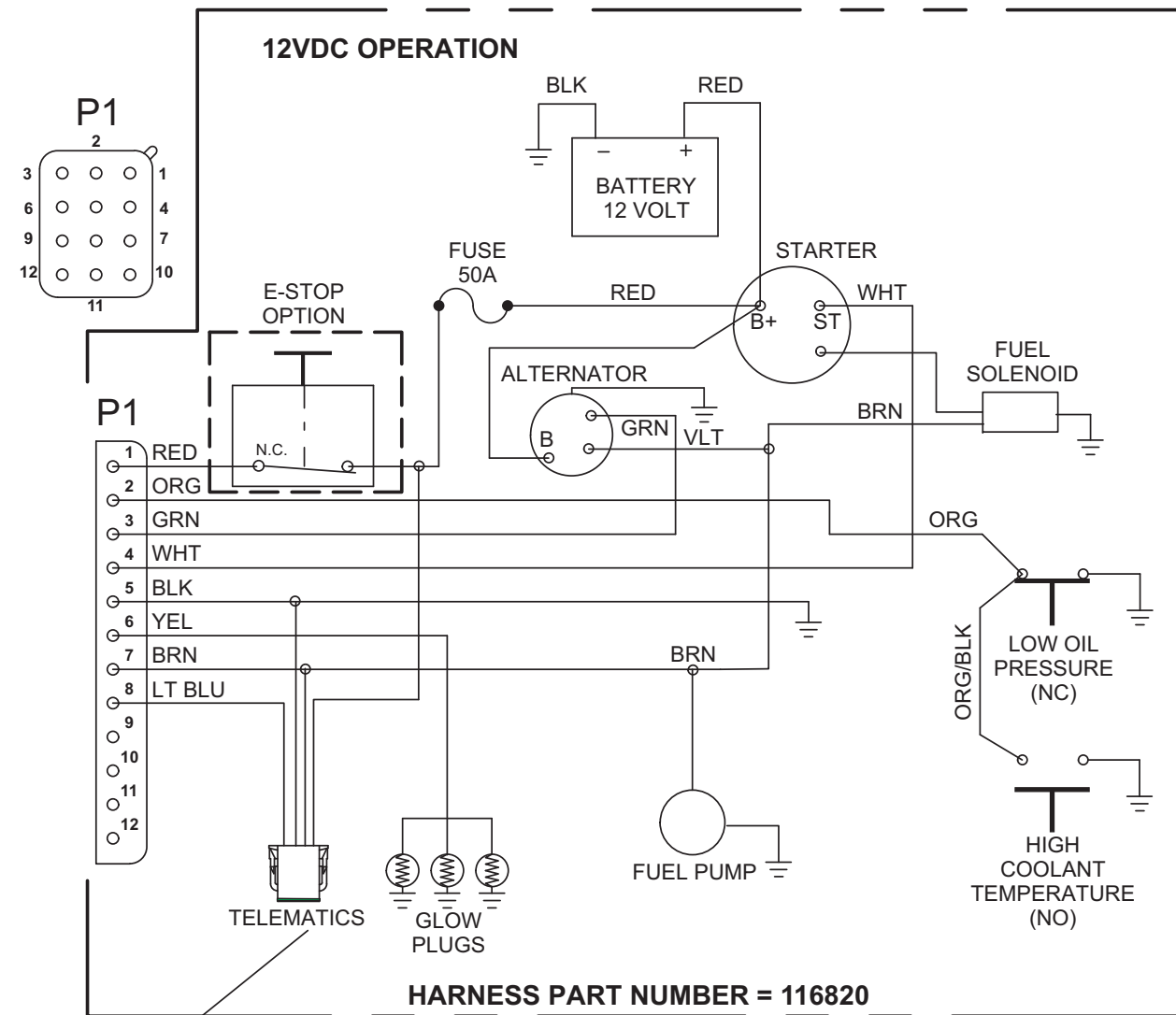

TELEMATICS		
PIN#	CKT#	COLOR
1	TEL BAT	RD
2	TEL GND	BK
3	TEL SIG	BRN
4	PLUG	-
5	PLUG	-
6	REMOTE ENABLE	LT BLU
7	PLUG	-
8	PLUG	-

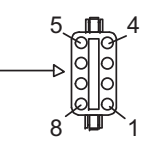

## RL4 DC Control Box, Timed Oil Switch



# RL4 DC CONTROL BOX, TIMED OIL SWITCH

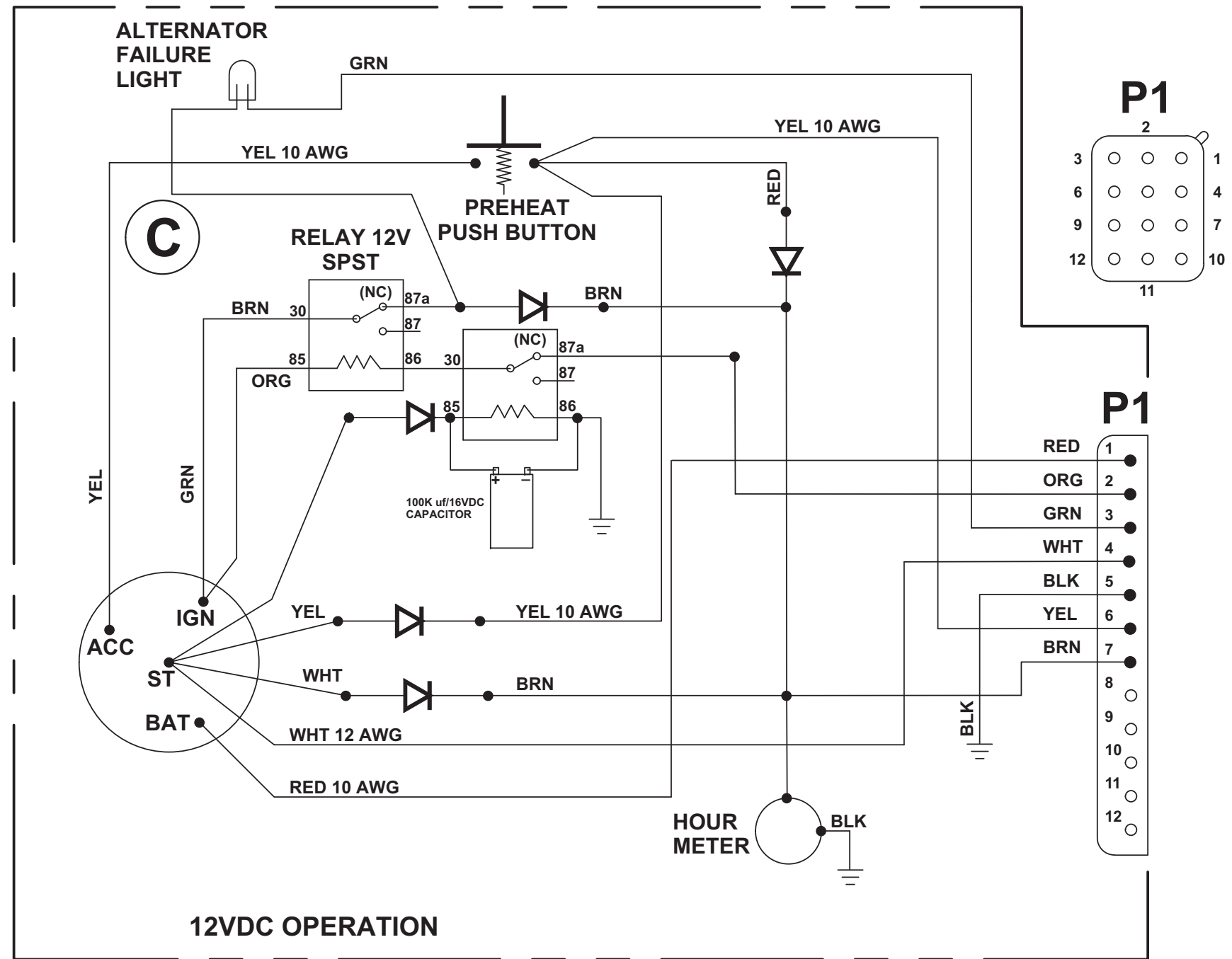

## RL4 DC Control Box, Low Fuel Shut Down



# RL4 DC CONTROL BOX, LOW FUEL SHUT DOWN

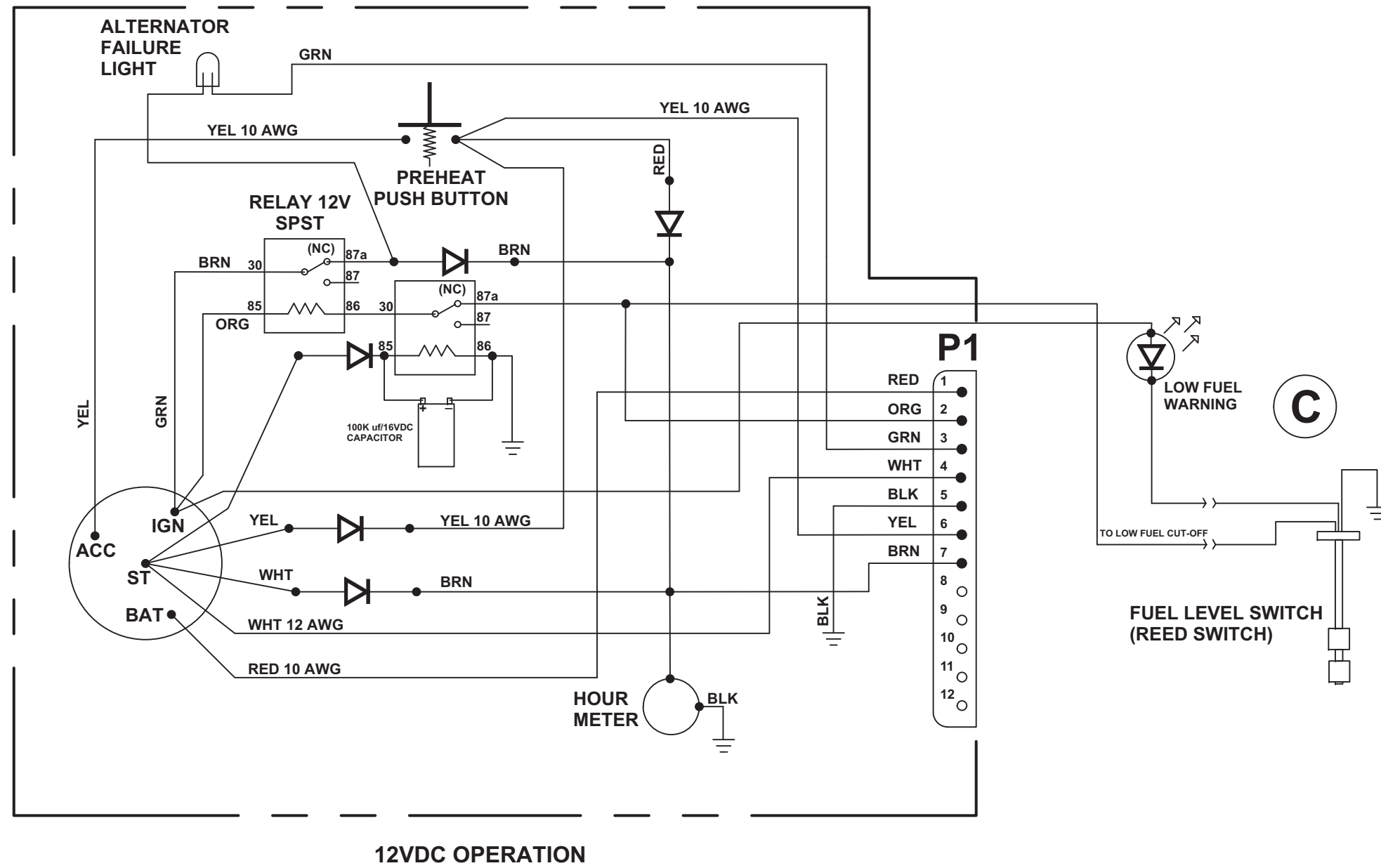



## RL4 Running Lights – Front Fairing Section



ITEM	PART NUMBER	DESCRIPTION	QTY
1	DT06-3S	DEUTSCH CONNECTOR, PLUG, 3-PIN	1
2	W3S	DEUTSCH CONNECTOR, WEDGE	1
3	0462-201-16	DEUTSCH CONNECTOR, SOCKET	3
4		7/16" BLACK PLASTIC WIRE LOOM W SLIT, .413 ID	85"
5		ELECTRICAL TAPE	24"
6	DT04-3P	DEUTSCH CONNECTOR, RECEPTACLE 3-PIN	1
7	W3P	DEUTSCH CONNECTOR, WEDGE	1
8	0460-202-16	DEUTSCH CONNECTOR, PIN	3
9		1/4" MALE NYLON INSULATED TERMINAL	4
10		16-14 1/4" RING NYLON INSULATED TERMINAL	0
11		WIRE, 18 GA, WHITE	182"
12		WIRE, 18 GA, GREEN/BROWN	149"
13		WIRE, 18 GA, GREEN	126"
14		WIRE, 18 GA, YELLOW/BROWN	149"
15		WIRE, 18 GA, YELLOW	126"
16		TIE WRAP	12
17		4-WAY, FLAT TAILER END CONNECTOR	1

## NEW RL4 RUNNING LIGHTS FRONT SECTION

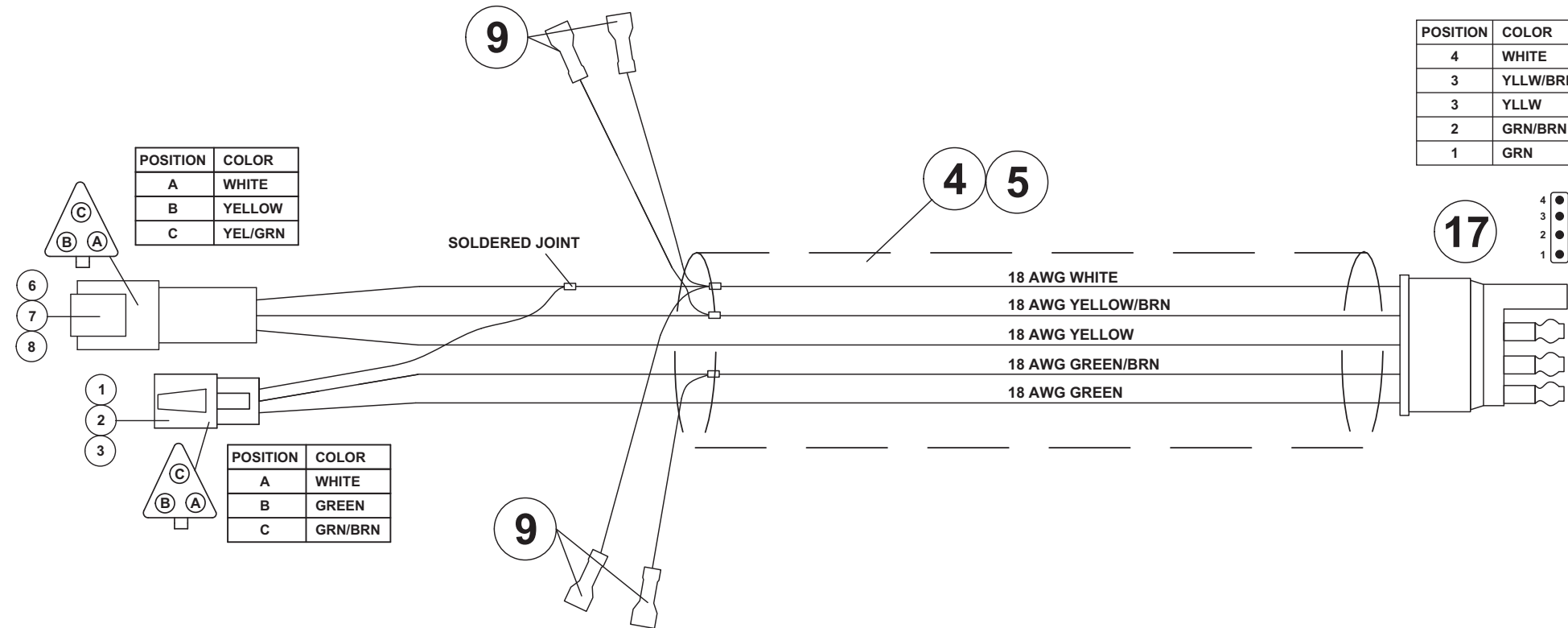

**RL4 Running Lights – Rear Fairing Section**



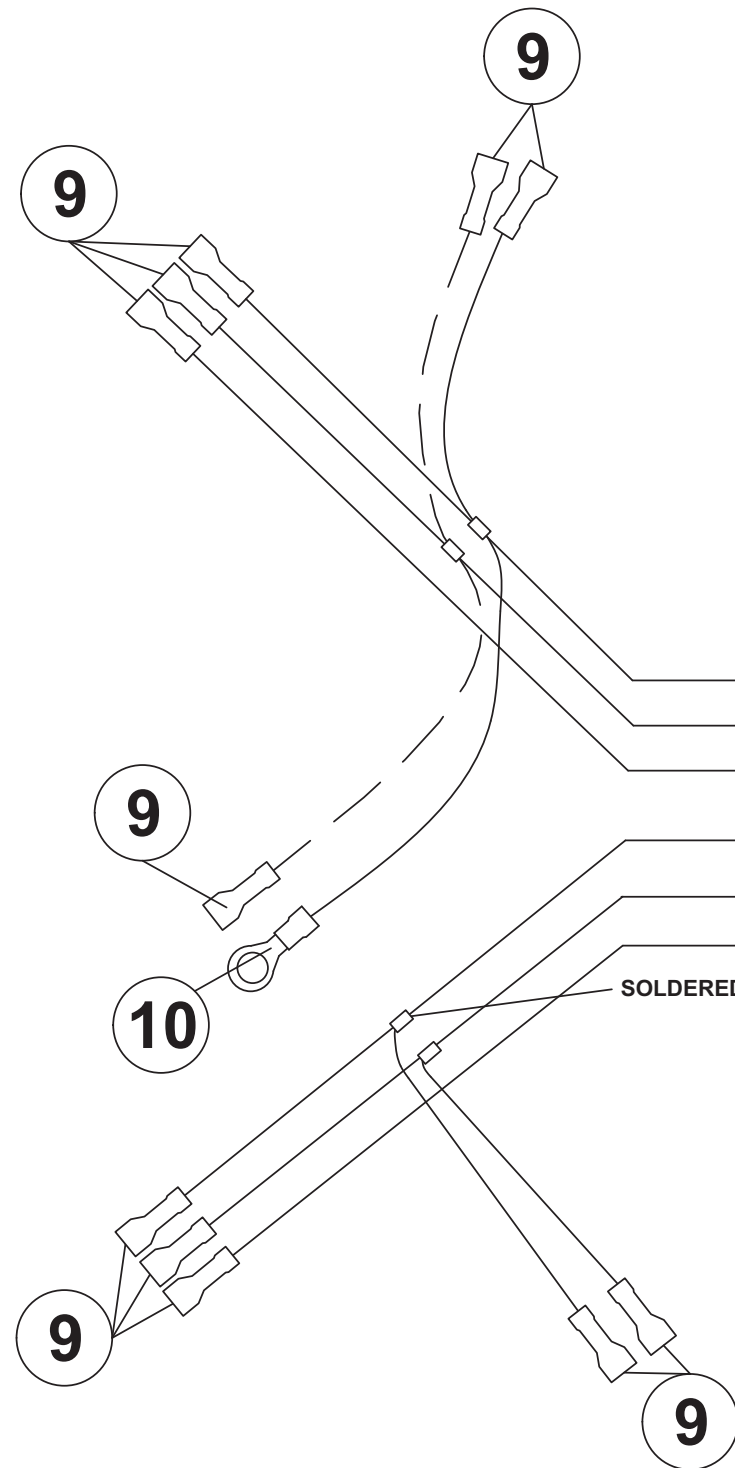

ITEM	PART NUMBER	DESCRIPTION	QTY
1	DT06-3S	DEUTSCH CONNECTOR, PLUG, 3-PIN	1
2	W3S	DEUTSCH CONNECTOR, WEDGE	1
3	0462-201-16	DEUTSCH CONNECTOR, SOCKET	3
4		7/16" BLACK PLASTIC WIRE LOOM W SLIT, .413 ID	0
5		ELECTRICAL TAPE	0
6	DT04-3P	DEUTSCH CONNECTOR, RECEPTACLE 3-PIN	1
7	W3P	DEUTSCH CONNECTOR, WEDGE	1
8	0460-202-16	DEUTSCH CONNECTOR, PIN	3
9		1/4" MALE NYLON INSULATED TERMINAL	11
10		16-14 1/4" RING NYLON INSULATED TERMINAL	1
11		WIRE, 18 GA, WHITE	178"
12		WIRE, 18 GA, GREEN/BROWN	149"
13		WIRE, 18 GA, GREEN	84"
14		WIRE, 18 GA, YELLOW/BROWN	94"
15		WIRE, 18 GA, YELLOW	68"
16		TIE WRAP	30

### NEW RL4 RUNNING LIGHTS REAR SECTION

18 AWG WHITE

18 AWG YELLOW/BRN

18 AWG YELLOW

18 AWG WHITE

18 AWG GREEN/BRN

18 AWG GREEN

SOLDERED JOINT

POSITION	COLOR
A	WHITE
B	YELLOW
C	YEL/GRN

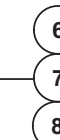
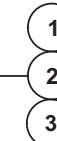

POSITION	COLOR
A	WHITE
B	GREEN
C	GRN/BRN

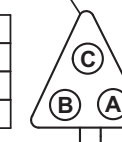

## RL4 Electrical Winch Option Wiring



# RL4 ELECTRICAL WINCH OPTION WIRING

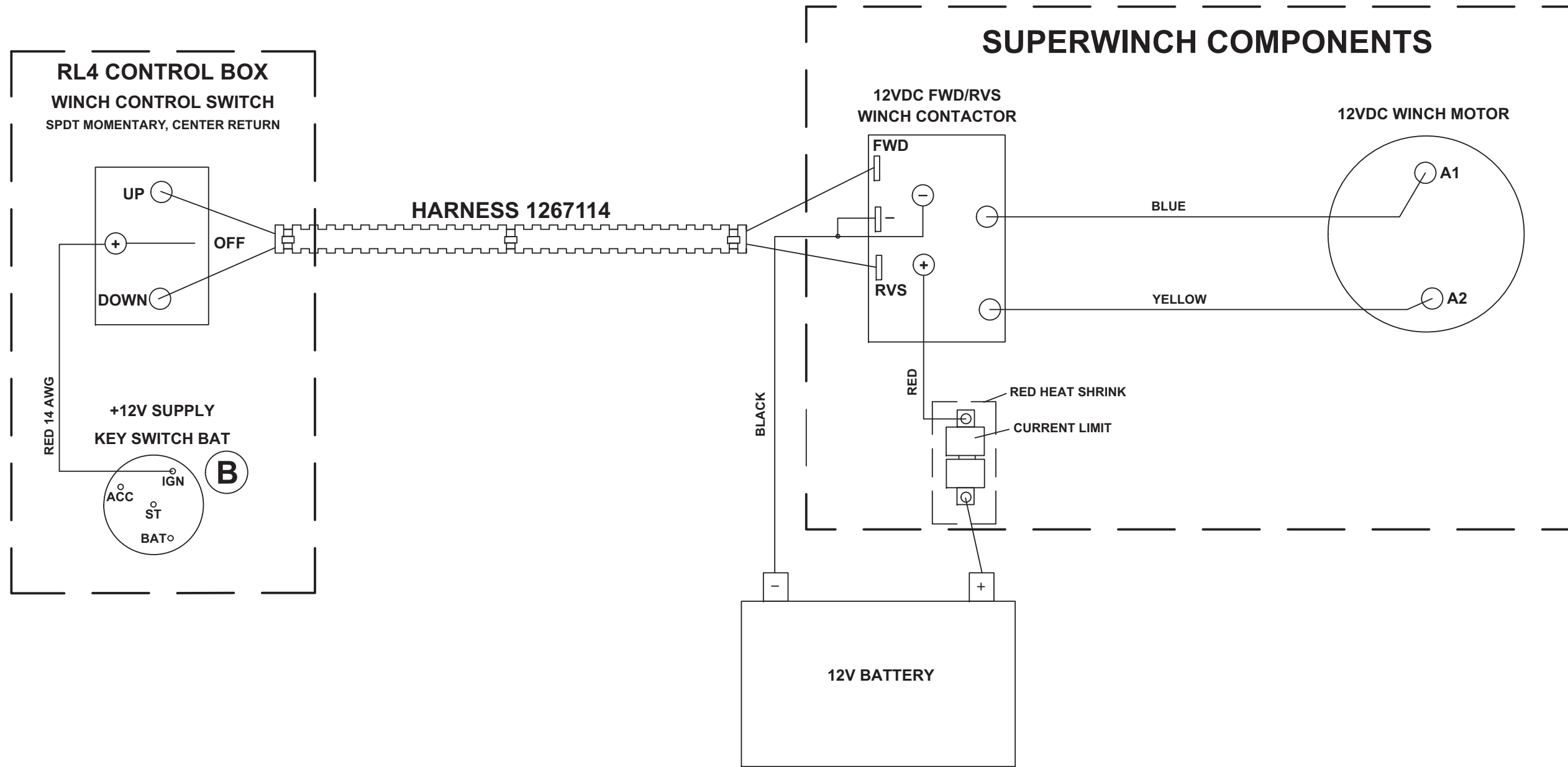

This page intentionally left blank.

California Proposition 65

## Warning

The exhaust from this product contains chemicals known to the State of California to cause cancer, birth defects or other reproductive harm.

Genie North America  
Phone 425.881.1800  
Toll Free USA and Canada  
800.536.1800  
Fax 425.883.3475

Genie Australia Pty Ltd.  
Phone +61 7 3375 1660  
Fax +61 7 3375 1002

Genie China  
Phone +86 21 53853768  
Fax +86 21 53852569

Genie Singapore  
Phone +65 67533544  
Fax +65 67533544

Genie Japan  
Phone +81 3 6436 2020  
Fax +81 3 5445 1231

Genie Korea  
Phone +82 2 558 7267  
Fax +82 2 558 3910

Genie Brasil  
Phone +55 11 4082 5600  
Fax +55 22 4082 5630

Genie Holland  
Phone +31 183 581 102  
Fax +31 183 581 566

Genie Sweden  
Phone 0046 3157 5101  
Fax 0046 3157 5104

Genie France  
Phone 0033 237 260 986  
Fax 0033 237 260 998

Genie Iberica  
Phone 0034 900 808 110  
Fax 0034 935 725 080

Genie Germany  
Phone 0800 180 9017  
Phone 0049 4221 491 810  
Fax 0049 4221 491 820

Genie U.K.  
Phone 0044 1476 584 333  
Fax 0044 1476 584 330

Genie Mexico City  
Phone +52 55 5666 5242  
Fax +52 55 5666 3241

Distributed By: