



04/21/2008

VISIT THE LIFETIME WEB SITE:  
[WWW.LIFETIME.COM](http://WWW.LIFETIME.COM)

**\*\* Do Not Contact the Store \*\***  
***For Assistance, including missing or broken parts,  
Call Customer Service at:  
1 (800) 225-3865***

30" Shed Extension Kit 11' Sheds

MODEL #0125

ASSEMBLY  
INSTRUCTIONS AND  
OWNER'S MANUAL

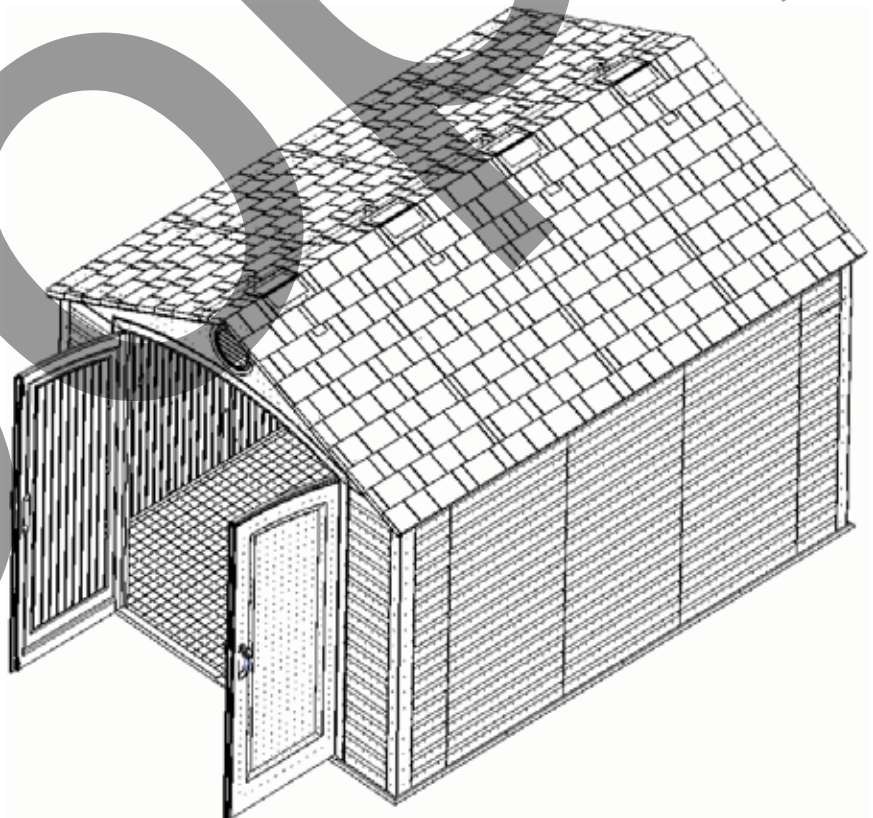

Save this instruction in the event you must contact the manufacturer for replacement parts.

INSTRUCTION #1036820

**\*\*A MINIMUM OF TWO ADULTS ARE REQUIRED FOR ASSEMBLY\*\***



## BEFORE BEGINNING ASSEMBLY



Identify and inventory all parts using the checklist boxes on the Parts List. Keep the hardware bags and their contents separate. If any parts are missing, call our Customer Service Department.



## SAFETY INSTRUCTIONS



**Failure to follow these safety instructions may result in serious injury or property damage.** Proper and complete assembly, use and supervision is essential for proper operation and to reduce the risk of accident or injury. A high probability of serious injury exists if this display is not installed, maintained, or operated properly. • If using a ladder during assembly, use extreme caution. Follow all warnings and cautions on the ladder carefully. • 2 people are required for assembly. • Misuse could result in system failure. • If technical assistance is required, contact the manufacturer.  
*Most injuries are caused by misuse and/or failure to follow instructions.*

## PARTS LIST

|   |         |                              |    |
|---|---------|------------------------------|----|
| AA  | 1028035 | Center Roof Cap (1021070)*   | 1  |
| AB  | 1019503 | Gutter Channel               | 2  |
| AC  | 1007977 | Wall Support Channel         | 2  |
| AD  | 1007988 | Truss Channel                | 1  |
| AE  | 1007996 | Inner Roof Panel (1000496)*  | 2  |
| AF  | 1007997 | Wall Panel (1000272)*        | 2  |
| AJ  | 1008000 | Inner Floor Panel (1000463)* | 2  |
| AK  | 1008001 | Roof Support Strip           | 4  |
| AM  | 1020423 | Truss Support Strip          | 2  |
| <b>Shed Parts Box [1019238]</b>               |         |                              |    |
| GA  | 1010271 | 1/2" Foam Cube               | 4  |
| <b>Skylight Hardware Bag [1011616]</b>        |         |                              |    |
| LA  | BW01200 | #10-1" Fender Washer         | 7  |
| LB  | 1010132 | #10 x 5/8" Pan Head Screw    | 7  |
| <b>Truss Extension Hardware Bag [1016014]</b> |         |                              |    |
| FA  | 1009117 | Floor Bracket                | 2  |
| FB  | 300072  | 1/4" x 1 1/2" Hex Bolt       | 11 |
| FC  | BN00300 | 1/4" Cap Nut                 | 11 |
| FD  | 1012933 | Center Gutter Connector      | 1  |
| <b>Shed Screw Hardware Bag [1011615]</b>      |         |                              |    |
| SS  | BS07500 | 1/4" x 5/8" Screw            | 60 |

LA

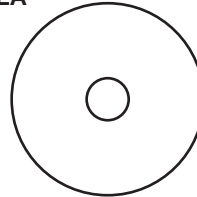

LB

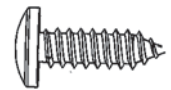

FA



FB

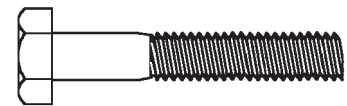

FC



SS

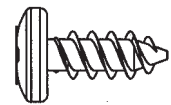

FD

GA

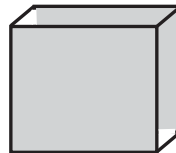

\* The number in Parentheses indicates the number molded into the plastic part.

### Tools and Materials Required for Assembly (Not Included)

1. 7/16" Wrenches (2)
2. 3/8" Wrenches (2)
3. #2 Phillips screwdriver or Electric drill with phillips head

## HARDWARE IS NOT ACTUAL SIZE (unless otherwise indicated)

AA

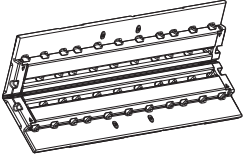

AE



AF



AJ

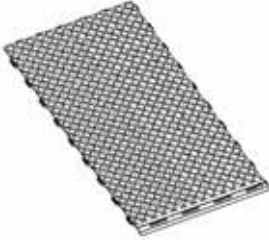

AK



AM



AB



AC

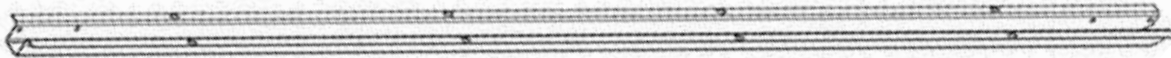

AD

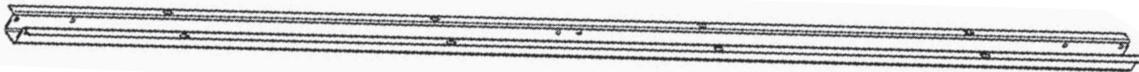

### Site Selection

- This extension kit adds another 30" to the length of your shed. Before beginning expansion of your shed be sure that your site can accommodate the new size.

### If you are Extending an Existing Shed

- See "Option 2" instructions on page 11. If you have not yet assembled your shed, use the "Option 1" instructions on the next page.

## Option 1: Add Extension Kit During Shed Assembly

1. Check contents of boxes and compare to parts listed on the Parts List.
2. Follow instructions that came with your shed, but when you come to the following sections of your Owner's Manual assemble the additional floor, wall, window and truss parts that are included in this kit.

### Site Selection

**Opt. 1.1:** Add 30" to the length of your site's wooden platform (shown) or cement platform; the width will remain the same. This may require the use of additional lumber or other materials.

**Note:** Floor studs are all 16" on center with one at 14" on center. Refer to Site Selection & Platform Instructions in Owner's Manual.

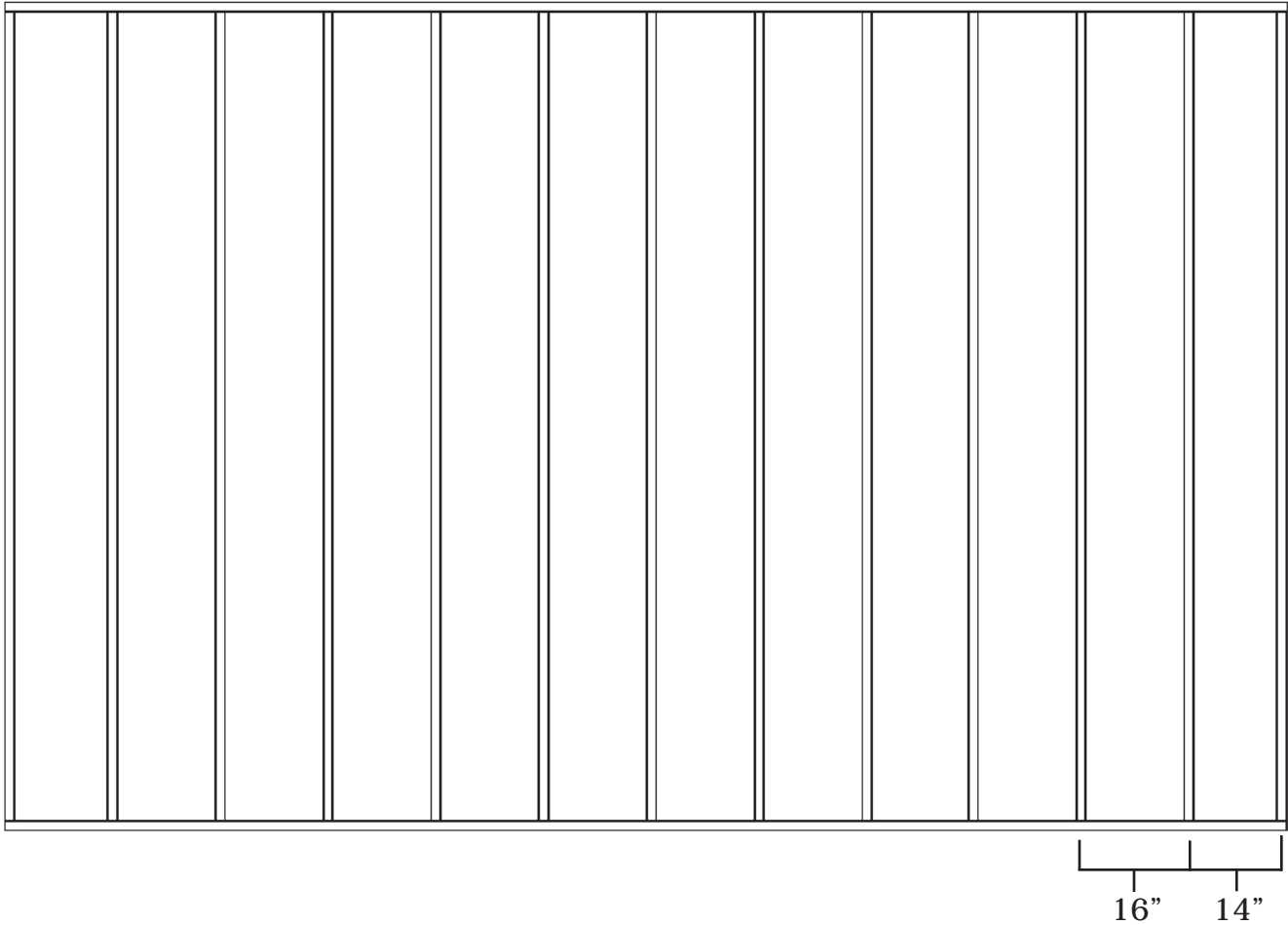

## Assemble Floor

**Note:** Refer to the corresponding section in your Owner's Manual for more specific instructions.

**Opt. 1.2:** Fit together the two Inner Floor Panel extensions (AJ).

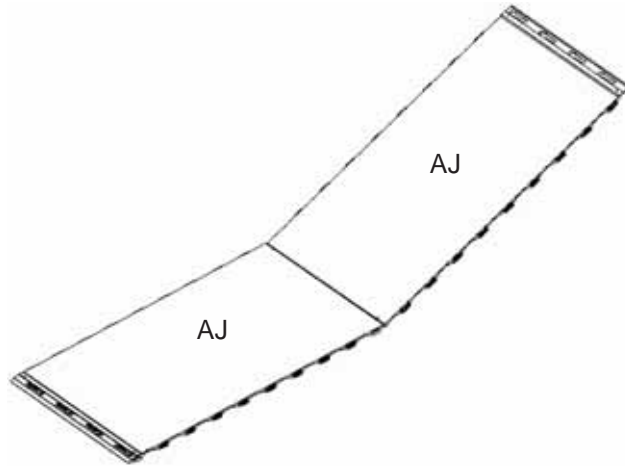

**Opt. 1.3:** Connect the Inner Floor Panel extensions (AJ) to the other Inner Floor Panels and finish off by connecting the last two Outer Floor Panels that came with your shed.

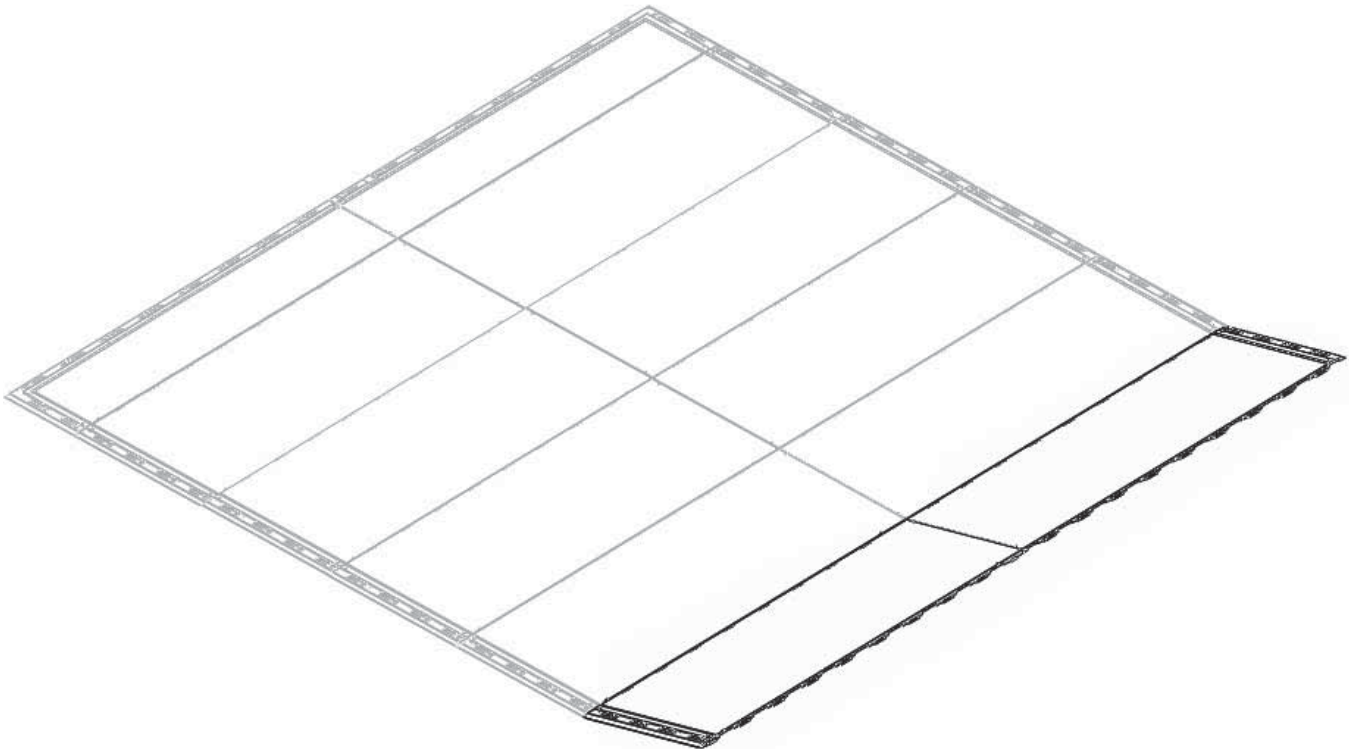



## Assemble Wall (Right or Left)

**Note:** Refer to the corresponding section in your Owner's Manual for more specific instructions.

**Opt. 1.4:** Add the two **Wall Panel (AF)** extensions as you attach the other Wall Panels around the shed.

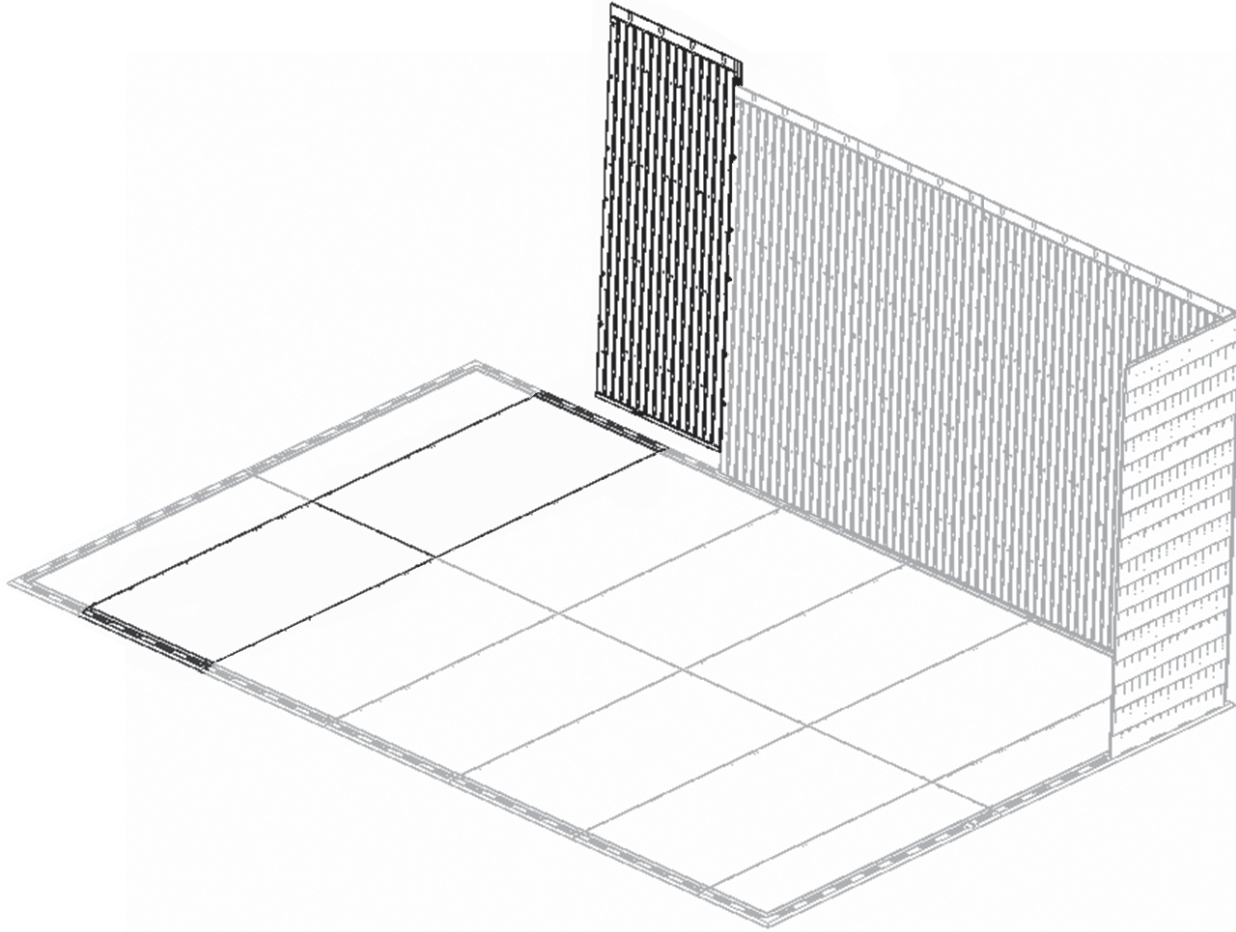

## Assemble Truss Frames

**Note:** Refer to the corresponding section in your Owner's Manual for more specific instructions.

**Opt. 1.5:** Fit two **Truss Support Strips (AM)** together. Bolt **Truss Support Strips, Center Gutter Connector (FD)** and two **Gutter Channels (AB)**. Refer to the Owner's Manual that came with your shed when assembling other truss frames.

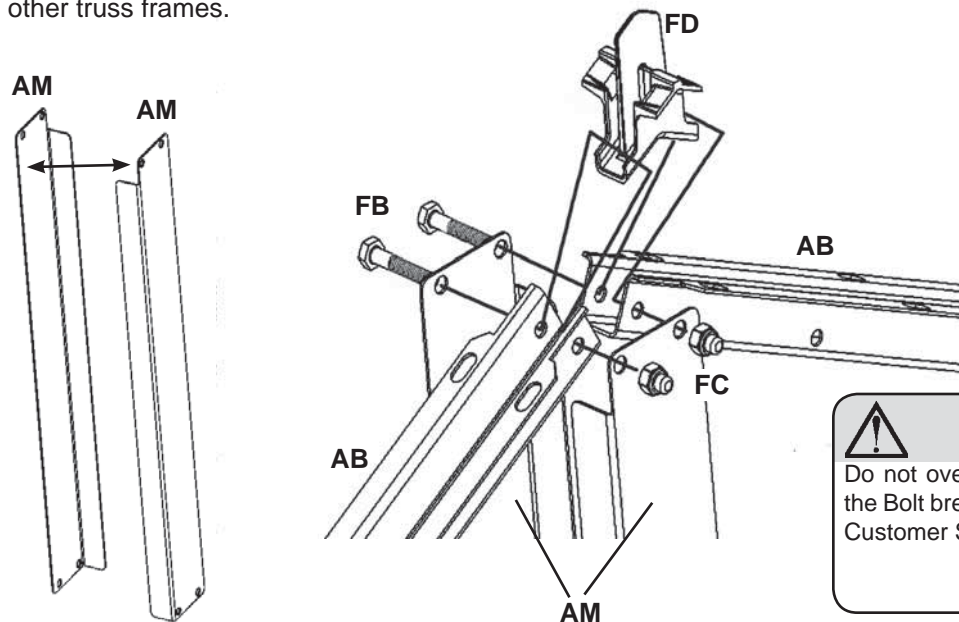

*Finger Tighten Hardware*



### WARNING



Do not overtighten the Cap Nut. If the end of the Bolt breaks through the plastic cap, call our Customer Service Department.

**Opt. 1.6:** Attach a **Gutter Channel (AB)** (Truss Support Strips fit inside Gutter Channel). Attach **Truss Channel (AD)** to **Gutter Channel** at each end.

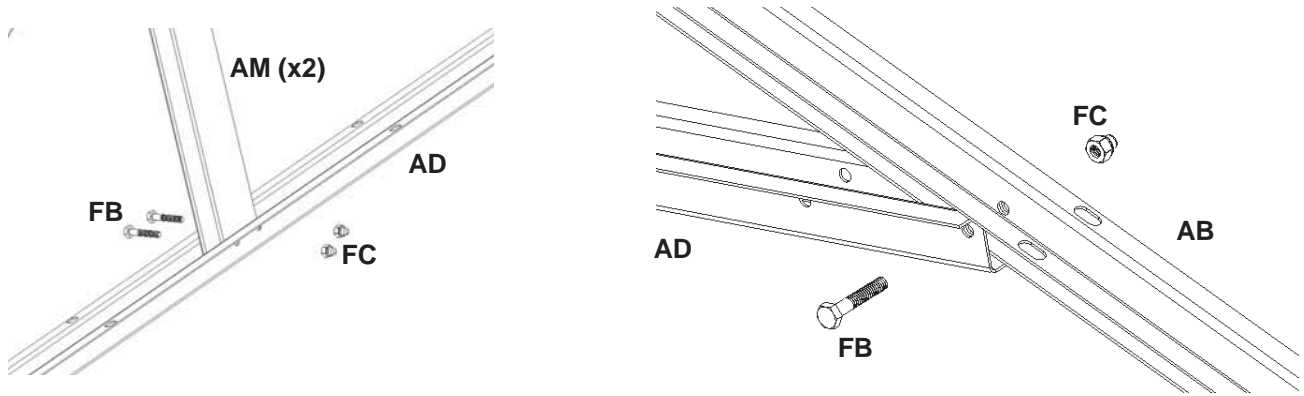

**Tighten All Hardware**

**Opt. 1.7:** Attach **Truss Assembly** to two **Wall Support Channels (AC)**. Do not completely tighten the **Cap Nut (FC)** until after truss is secured to the wall.

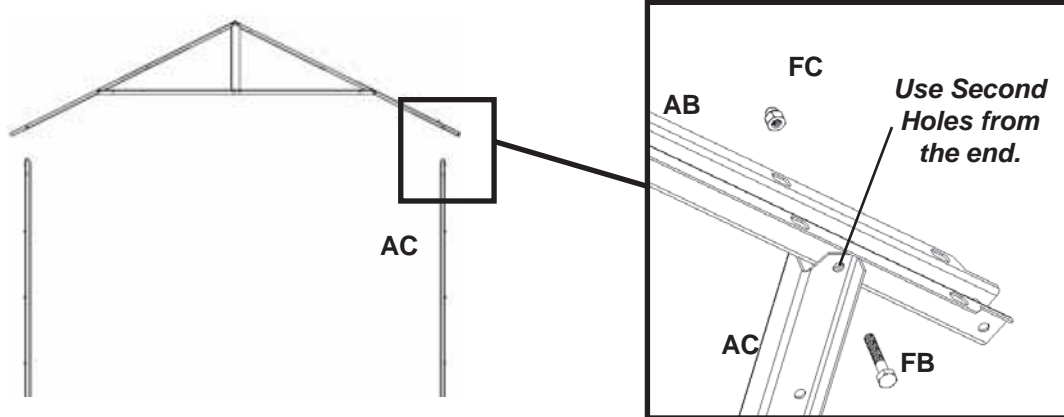

**WARNING**

Do not overtighten the Cap Nut. If the end of the Bolt breaks through the plastic cap, call our Customer Service Department.

**Opt. 1.8:** Continue attaching other **Truss Assemblies** to **Wall Support Channels (AC)** according to your original Shed Instructions.

## Install Truss Assemblies

**Opt. 1.9:** Follow Owner's Manual instructions to assemble the connect **Truss Frames** included in this kit to your shed, along with those that came with your shed.

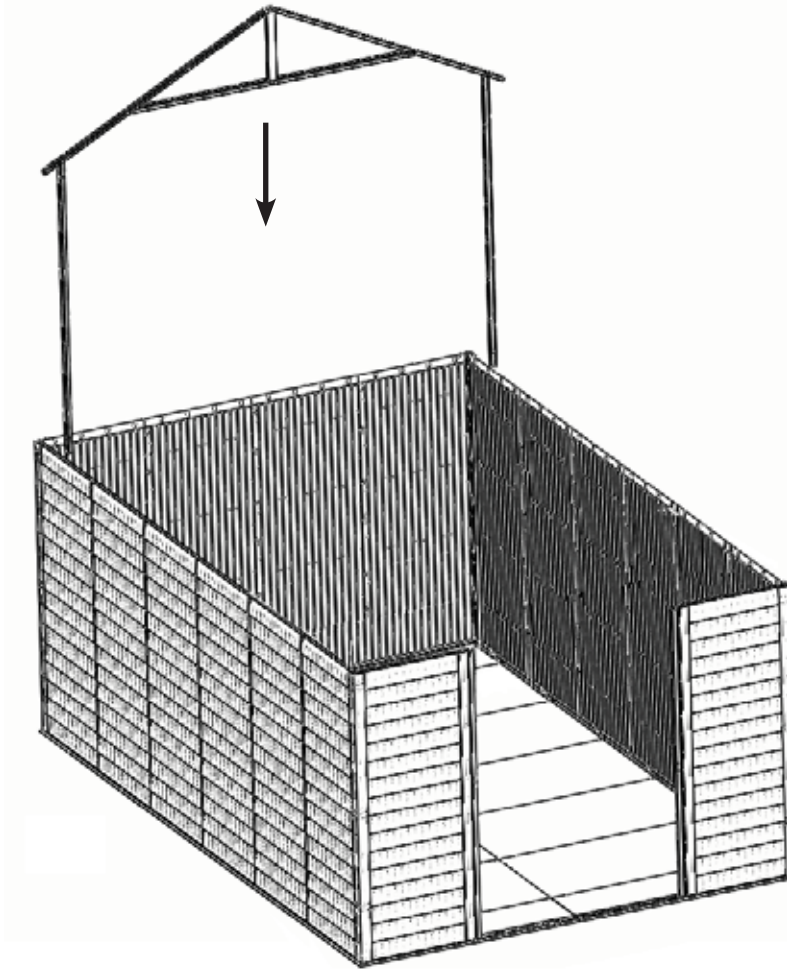

**Opt. 1.10:** Attach one **Floor Bracket (FA)** to each **Wall Support Channel (AC)** and fasten the **Floor Bracket** to the floor. You only need to do this step if you plan to anchor your shed. See the "Anchoring the Shed" step at the end of your Owner's Manual.

**Tighten all Hardware.**

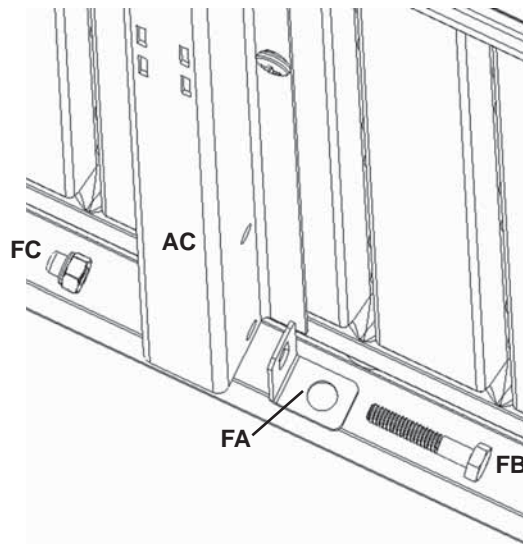

### WARNING



Do not overtighten the Cap Nut. If the end of the Bolt breaks through the plastic cap, call our Customer Service Department.



## Install Roof Sections

**Opt. 1.11:** Attach **Inner Roof Panels (AE)** using **Screws (SS)** Always start inserting screws at the top of the **Inner Roof Panel**. Refer to the Owner's Manual that came with your original shed.

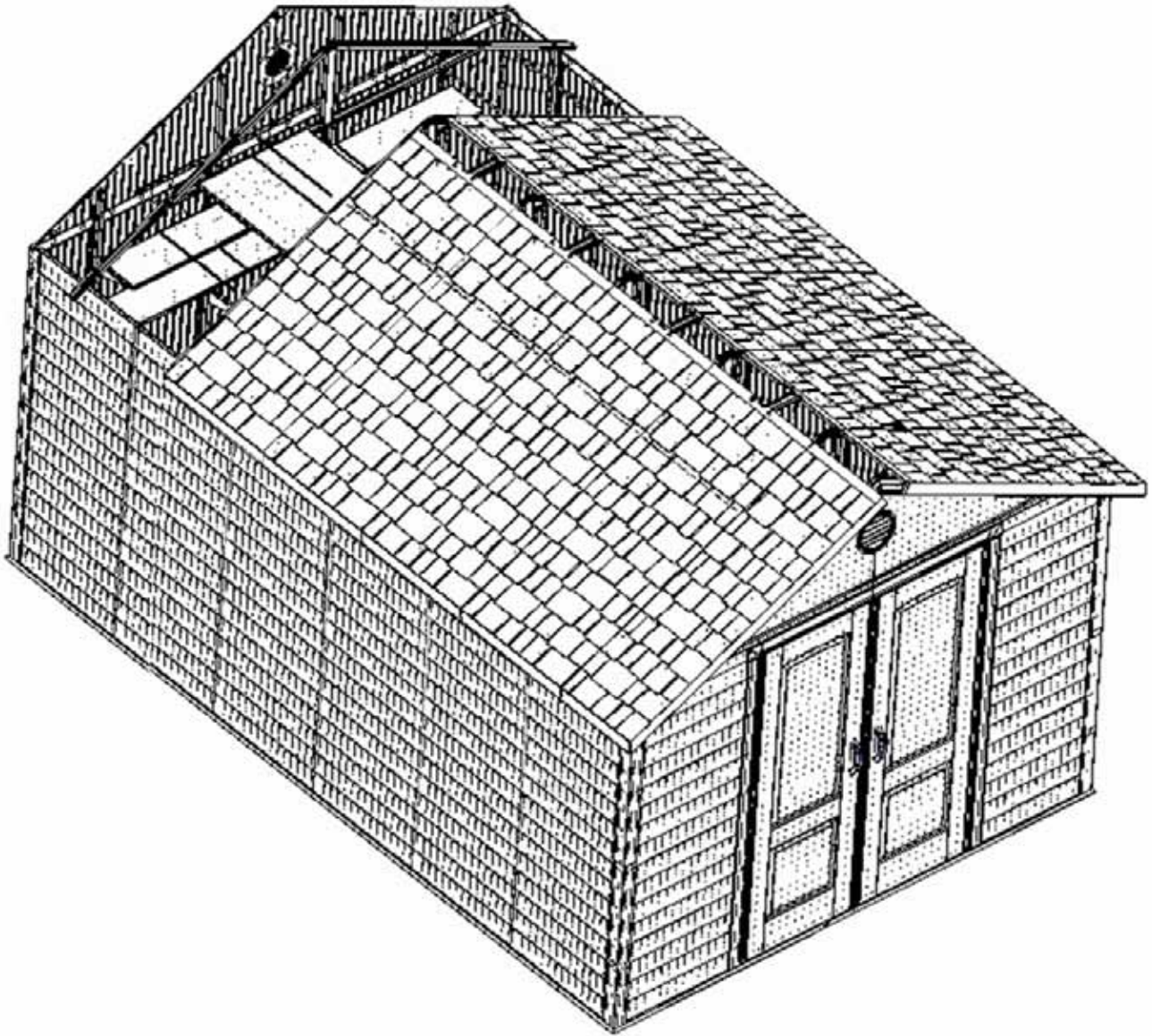

**Opt. 1.12:** Install a **Center Roof Cap (AA)** with **1/4" x 5/8" Screws (SS)** to the **Roof Panels**.



*Only use a hand screwdriver for the Skylights*

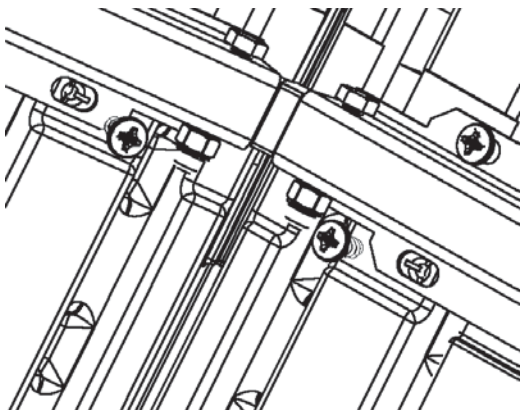

*Attach Roof Cap (AA) to Truss on both sides with 1/4" x 5/8" Screws (SS).*

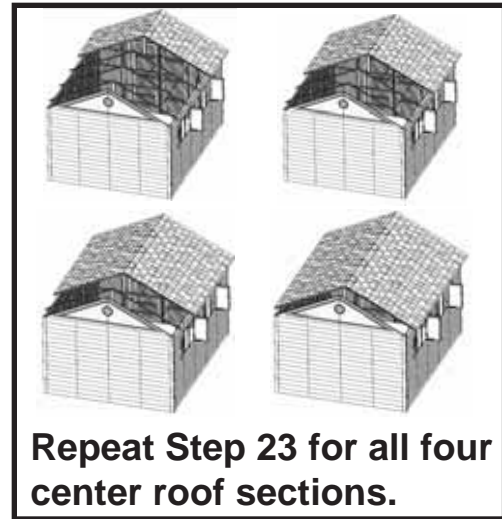

**Repeat Step 23 for all four center roof sections.**

**Opt. 1.13:** Fold **End Roof Cap** along its hinge. Install it at the front of the shed.

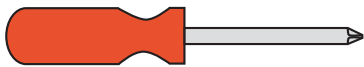

*Only use a hand screwdriver on this step*

**Note:** This is an exterior view.

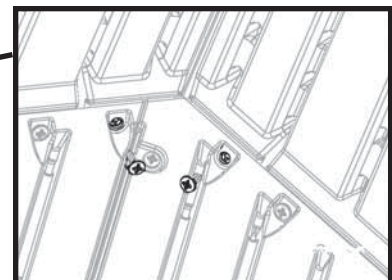
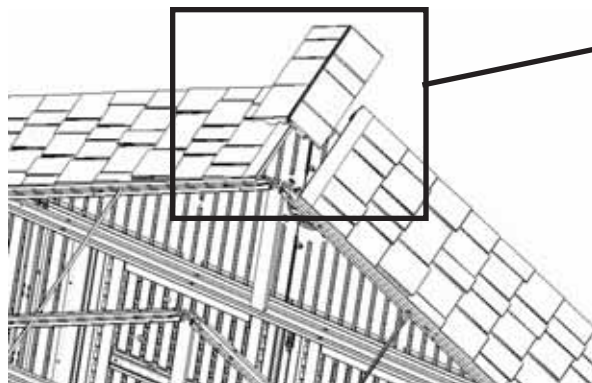

**Note:** This is an interior upward view.

## Option 2: Add Extension Kit to an Existing Shed

**\*\*Save all hardware for re-assembly!\*\***

**ATTENTION: If your existing shed is anchored to the ground, remove all anchoring hardware before following these steps.**

**Opt. 2.1:** Remove the four **Lower Roof Panels** and two **Center Roof Caps** that are highlighted below (if the existing Shed has **Skylights**, leave them attached to the **Roof Caps**).

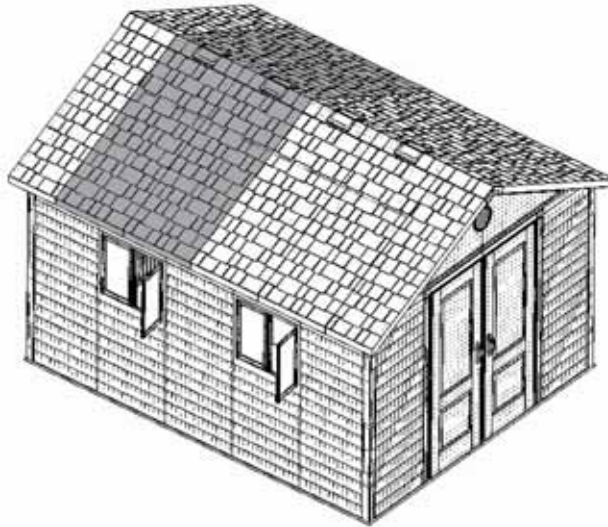

**Note:** Your shed may be shorter than shown above. Skip the very back Roof Panels (slightly more narrow than the middle Roof Panels) and then remove the next two Roof Panels from each side of the shed (along with the connected Roof Caps).

---

**Repeat Steps 2.2 through 2.4 for both sides of the shed.**

**Opt. 2.2:** Remove all screws from the highlighted Wall Panel that connect it to adjoining Wall Panels and to the Wall Support.

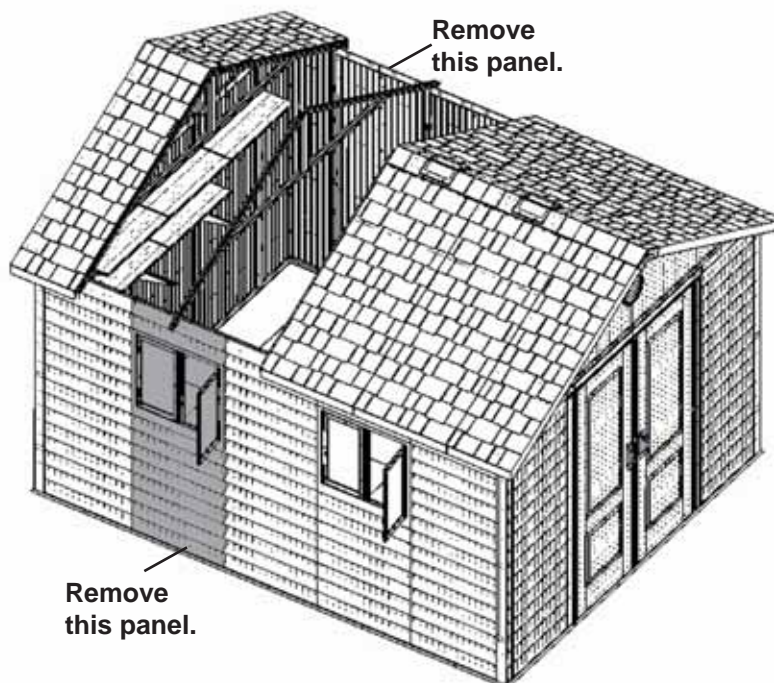



**Opt. 2.3:** Tip the **Wall Panel** inward.

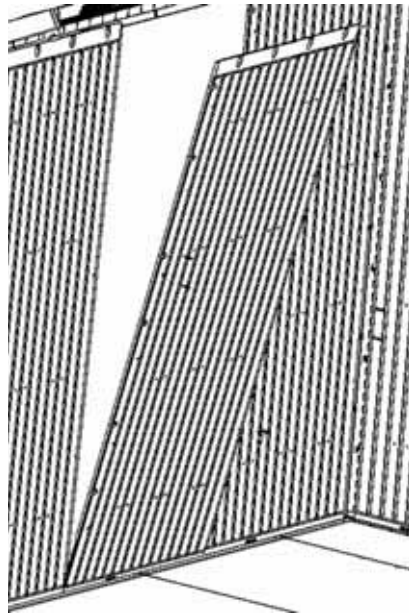

**Note:** To remove a Wall Panel, slide it to the left (when looking at it from inside the shed) until it lifts out.

**Opt. 2.4:** Use a long flat screwdriver to gently pry the bottom corner of the **Wall Panel** so that it has room to slide on the inside of other **Wall Panels**. Slide the **Wall Panel** to the left, and then remove the panel.

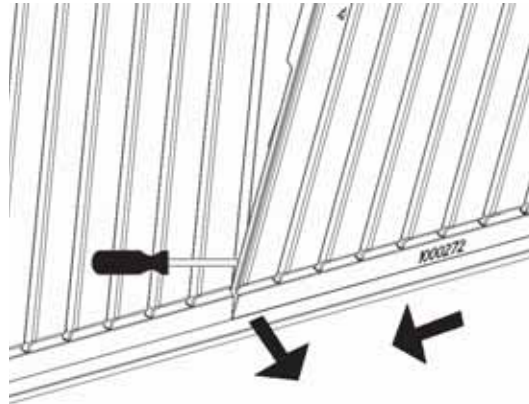

**Note:** As you remove the Wall Panels, have one person support the Truss assembly so that it does not fall over.

**Opt. 2.5:** Remove the **Truss** assembly and set it aside for later.

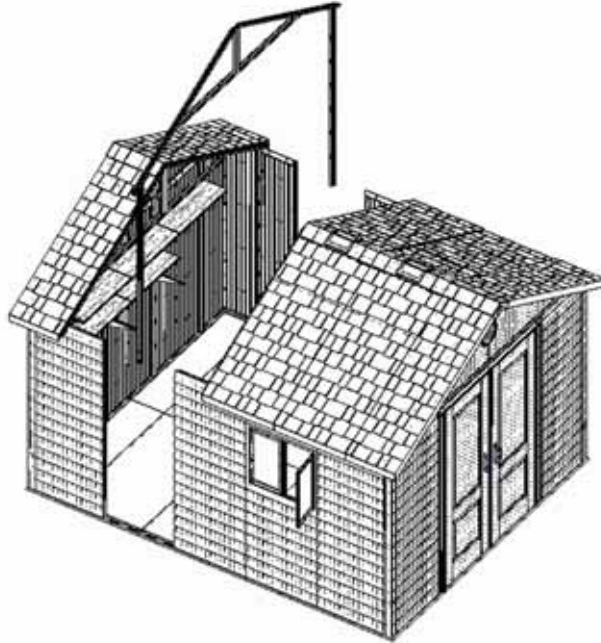

**Opt. 2.6:** With at least one person on each side of the shed, tip the back section of the shed forward to about a 45 degree angle and slide the back section away from the shed..

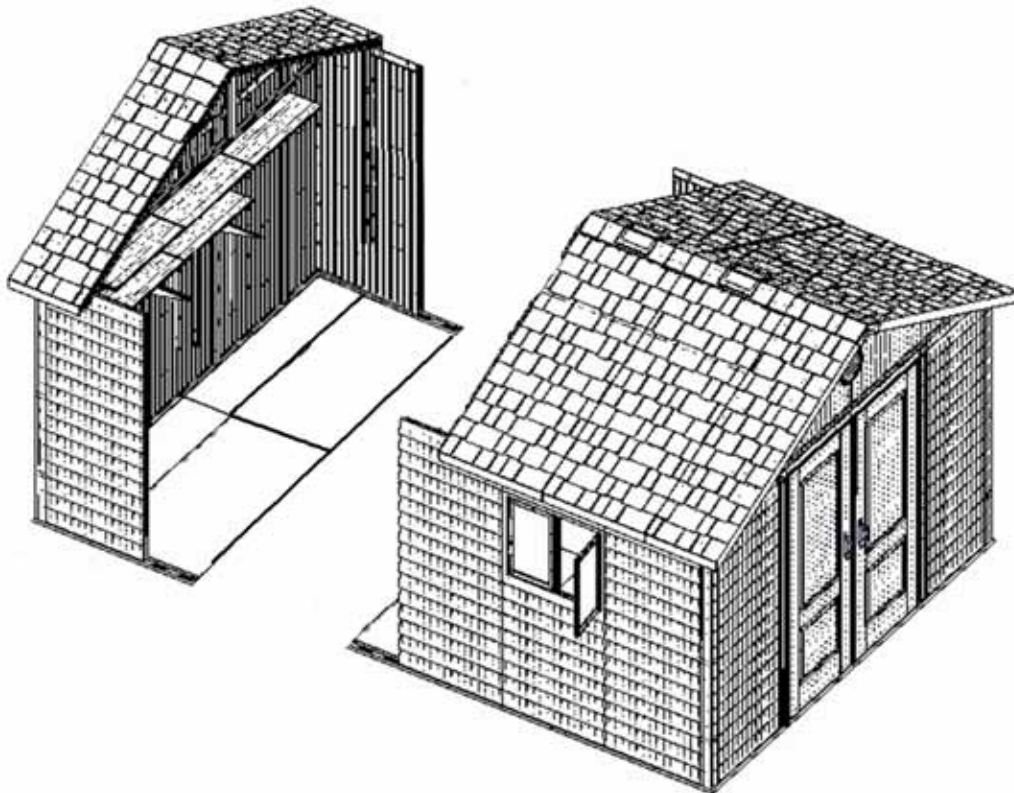



**Opt. 2.7:** Fit together the two Inner Floor Panel extensions (AJ).

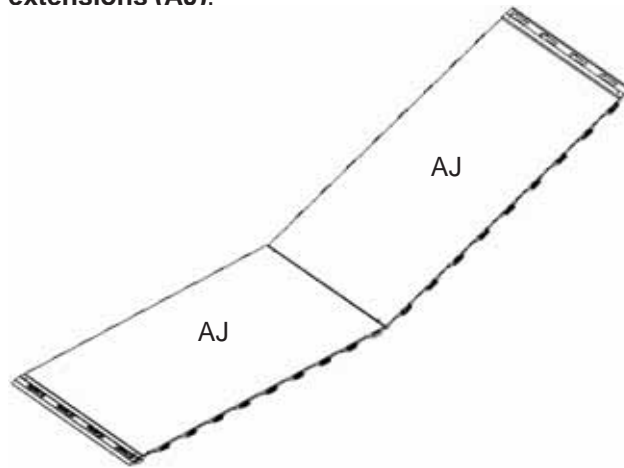

**Opt. 2.8:** Connect the Inner Floor Panel extensions (AJ) to the other Inner Floor Panels on the main section of the shed.

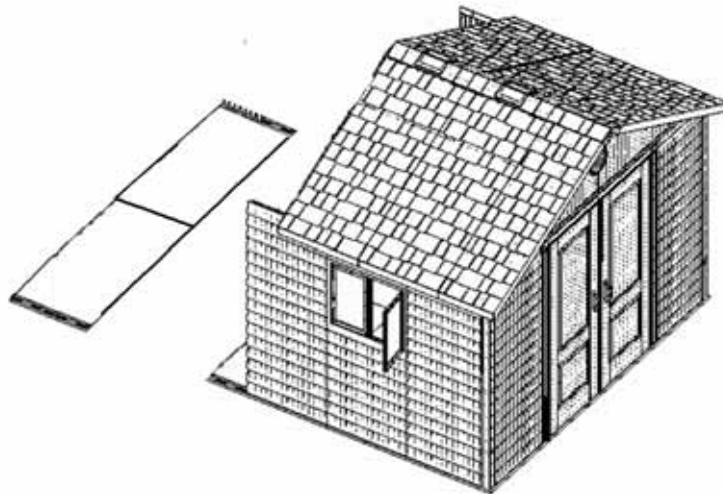

**Opt. 2.9:** With at least one person on each side of the shed, tip the back section of the shed forward to about a 45 degree angle and slide it forward to re-connect it to the rest of the shed.

**Opt. 2.10:** Fit two **Truss Support Strips (AM)** together. Bolt **Truss Support Strips, Center Gutter Connector (FD)** and two **Gutter Channels (AB)**. Refer to the Owner's Manual that came with your shed when assembling other truss frames.

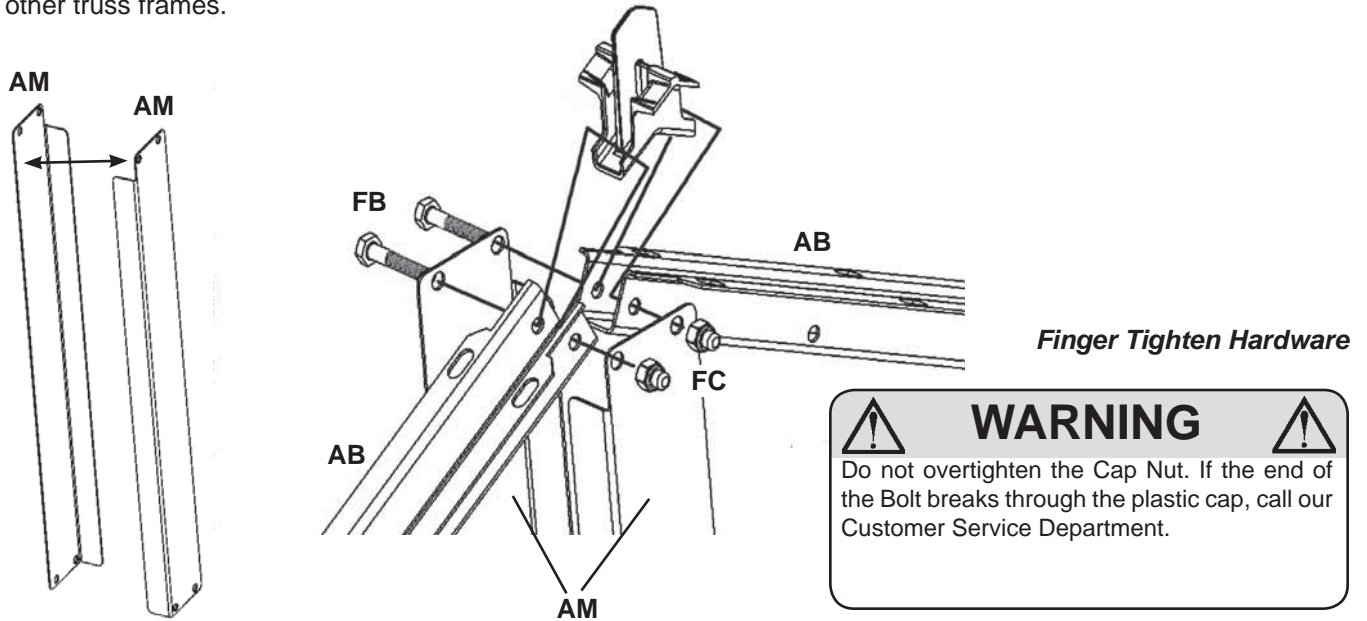

**Opt. 2.11:** Attach a **Gutter Channel (Truss Support Strips fit inside Gutter Channel)**. Attach **Truss Channel (AD)** to **Gutter Channel** at each end.

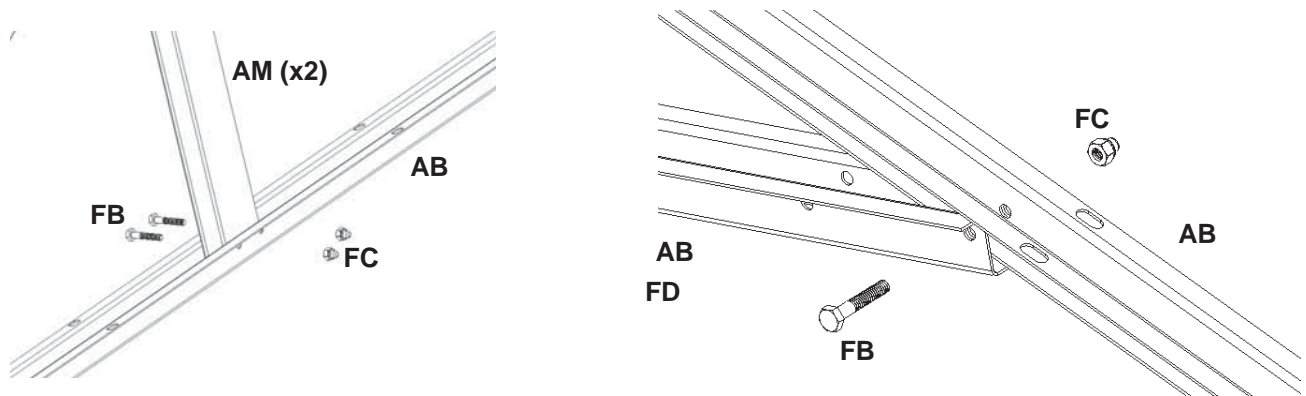

**Tighten All Hardware**

**Opt. 2.12:** Attach **Truss Assembly** to two **Wall Support Channels (AC)**. Do not completely tighten the **Cap Nut (FC)** until after truss is secured to the wall.

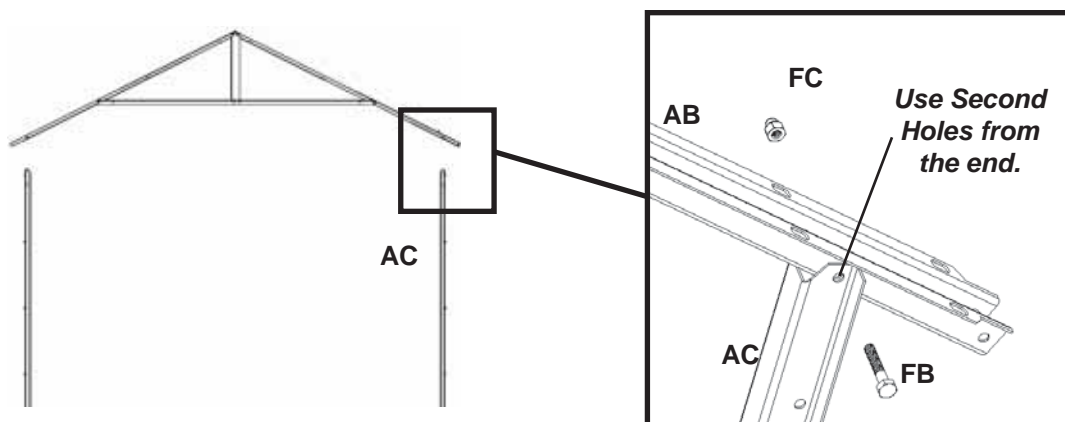

**Opt. 2.13:** Replace the two **Wall Panels** that were previously removed. Add the two new **Wall Panels** that came with this kit.

**Note:** As new panel slides into place be sure that screw bosses along the sides interlock properly with the adjoining Wall Panels.

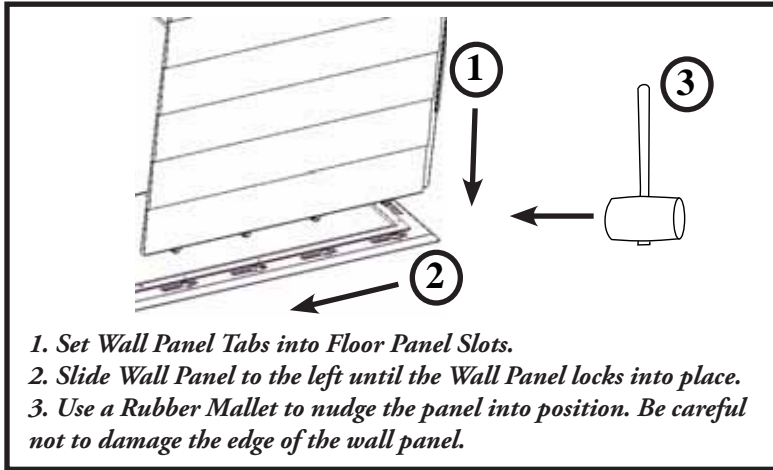

**Opt. 2.14:** Replace the **Truss** assembly that was previously removed. Add the new **Truss** assembly from steps 2.10 to 2.12.

**Opt. 2.15:** Replace the four **Lower Roof Panels** that were previously removed. Add the two new **Lower Roof Panels** that came with this kit.

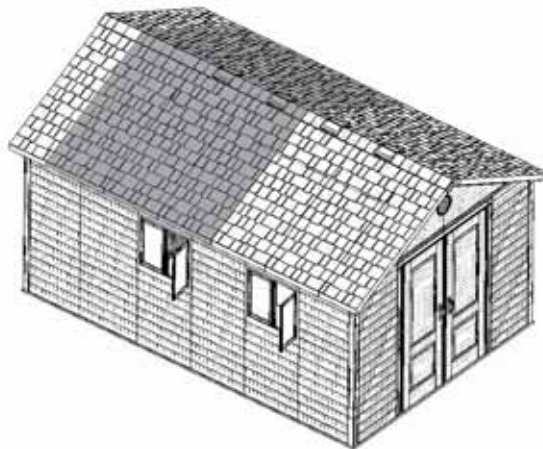

**Opt. 2.16:** Install the **Center Roof Cap (AA)** that came with this Kit.

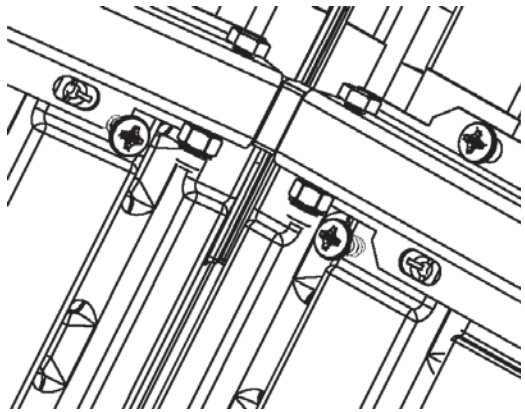

**Attach Roof Cap (AA) to Truss on both sides with 1/4" x 5/8" Screws (SS).**



**Only use a hand screwdriver for the Skylights**



**Opt. 2.17:** Along the outside edges of the shed, Fasten the new **Trusses** to the underside of the new **Roof Panels** (Fig. 1). Insert two **Foam Cubes (GA)** at each truss location (Fig. 2).

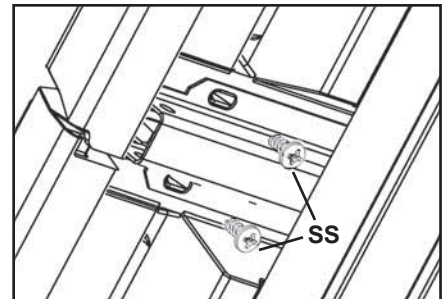
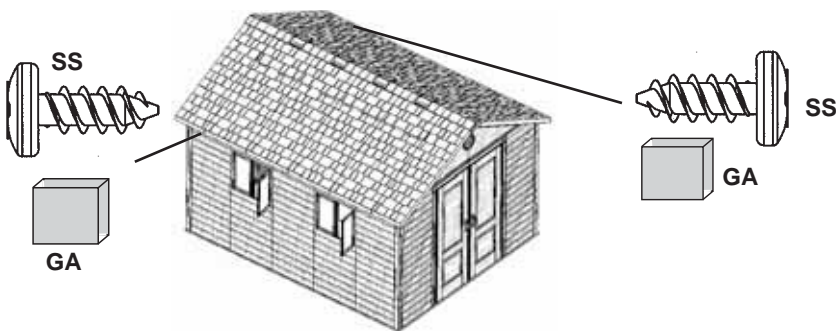

**Fig. 1**

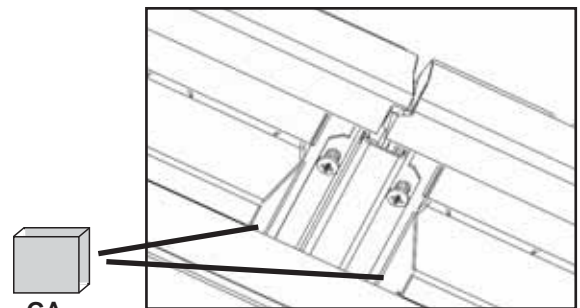

**Fig. 2**

**Enhance your Lifetime® Outdoor Shed by purchasing the following Shed Accessories:**

Model #

0111

**Window Shutters**

Two decorative window shutters.

0112

**Shed Lights (2 pack)**

Two battery powered Touch Lights.

0113

**16" Pegboard Strips w/ hardware**

Two sixteen inch Pegboard Strips with hooks. Great for hanging large items such as: rakes, shovels, or other tools.

0114

**10" Shelf Kit w/ hardware (5 pack)**

Five 30" x 10" Shelves with hardware.

0115

**14" Shelf Kit w/ hardware (5 pack)**

Five 30" x 14" Shelves with hardware.

6426

**60" Shed Extension Kit w/ 2 windows**

Extend your shed five feet for the ultimate storage building.

***To purchase shed accessories, visit us at:***

***[www.buylifetime.com](http://www.buylifetime.com)***

***Or call:***

***1 (800) 424-3865***

---

**Congratulations on your Lifetime® Outdoor Shed purchase. By following the instructions below, your new Lifetime shed should provide you with years of service and enjoyment.**

**Cleaning and Care**

The polyethylene walls and shelves are stain- and solvent resistant. To clean, use a mild soap and a soft-bristled brush. Abrasive cleaning materials may scratch the plastic and are not recommended. Repair scratches or rust spots on the metal by Sanding the affected area lightly; using a rust preventative spray primer; and finally, spraying with a high-gloss spray enamel paint. Avoid placing a direct heat source on or near surfaces unless using a heat barrier.

**For warranty details or to register your product, visit  
[www.lifetime.com](http://www.lifetime.com) or call 801-776-1532**