

RATIO	LUBRICANT OUTPUT (cu. in.)		RESERVOIR CAPACITY	AIR INLET	LUBRICANT OUTLET	LUBRICANT OPERATING PRESSURE (PSI)			
	PER CYCLE	PER MIN. (@100PSI)				TYPE OF SYSTEM	MINIMUM	MAXIMUM	RECOM-MENDED
40:1	*.11	12	12 LBS.	1/8" NPTF(F)	3/4" NPTF(F)	SL-1	1,850	3,550	2,500
						SL-11			
						SL-32	1,200	3,550	1,500
						SL-33			

### TYPICAL INSTALLATION

The 83167 Pump is used as the pumping unit for a centralized lubrication system having a single line circuit of SL-1, SLS-11, SL-32, OR SL-33 Injectors.

It is an air operated reciprocating pump that discharges an established amount of lubricant \*(.11 cu. in.) into the circuit for each pump cycle.

\*Based on lubricants that are free of entrapped air. Lubricants that are aerated will reduce output of pump.

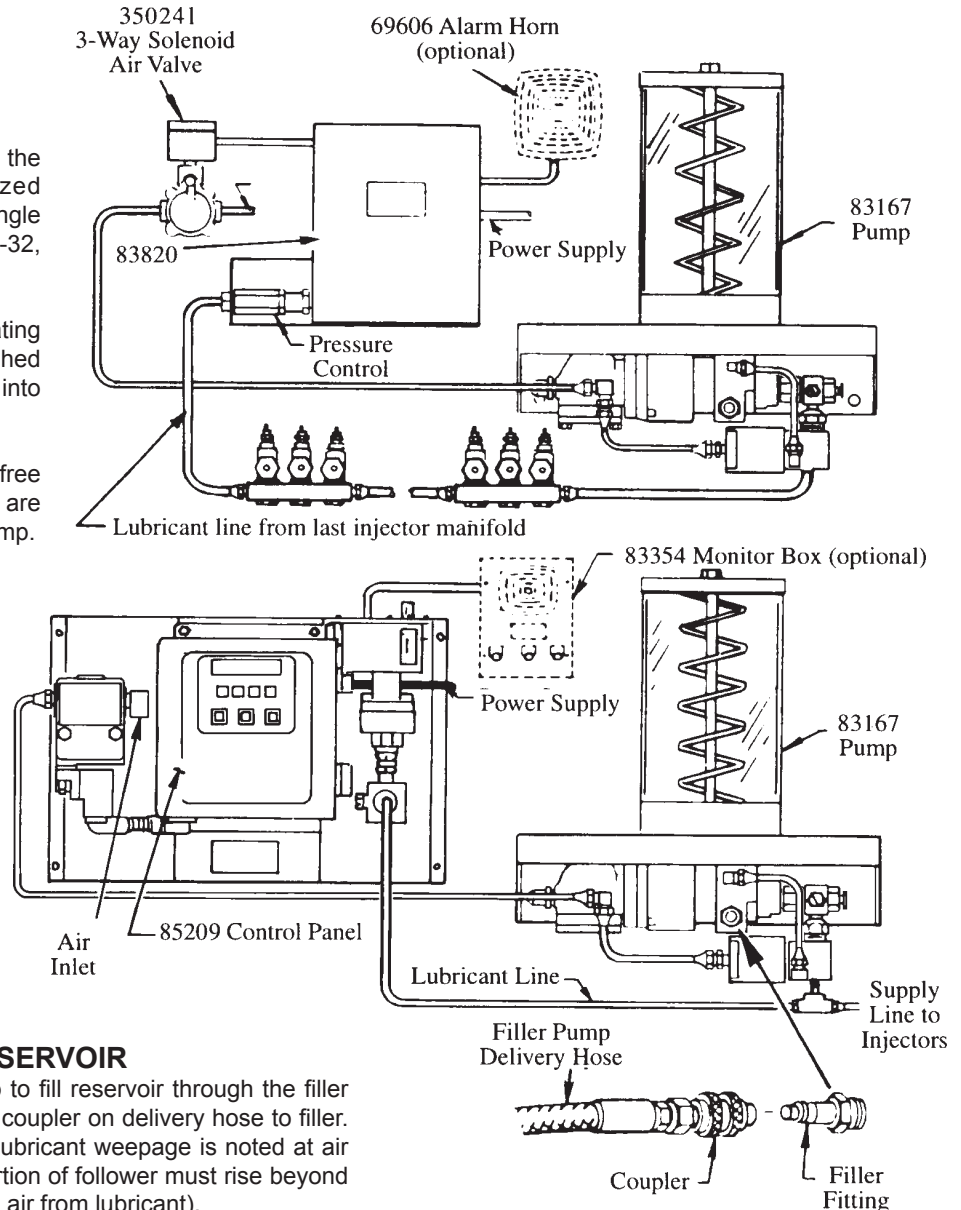

### FILL RESERVOIR

Use 81834 Manual Filler Pump to fill reservoir through the filler fitting in the pump body. Attach coupler on delivery hose to filler. Stroke filler pump handle until lubricant weepage is noted at air vent hole in reservoir (lower portion of follower must rise beyond air vent hole to expel entrapped air from lubricant).

NOTE: When filling the reservoir, caution should be used as extreme pressure can cause damage to reservoir and follower assembly.

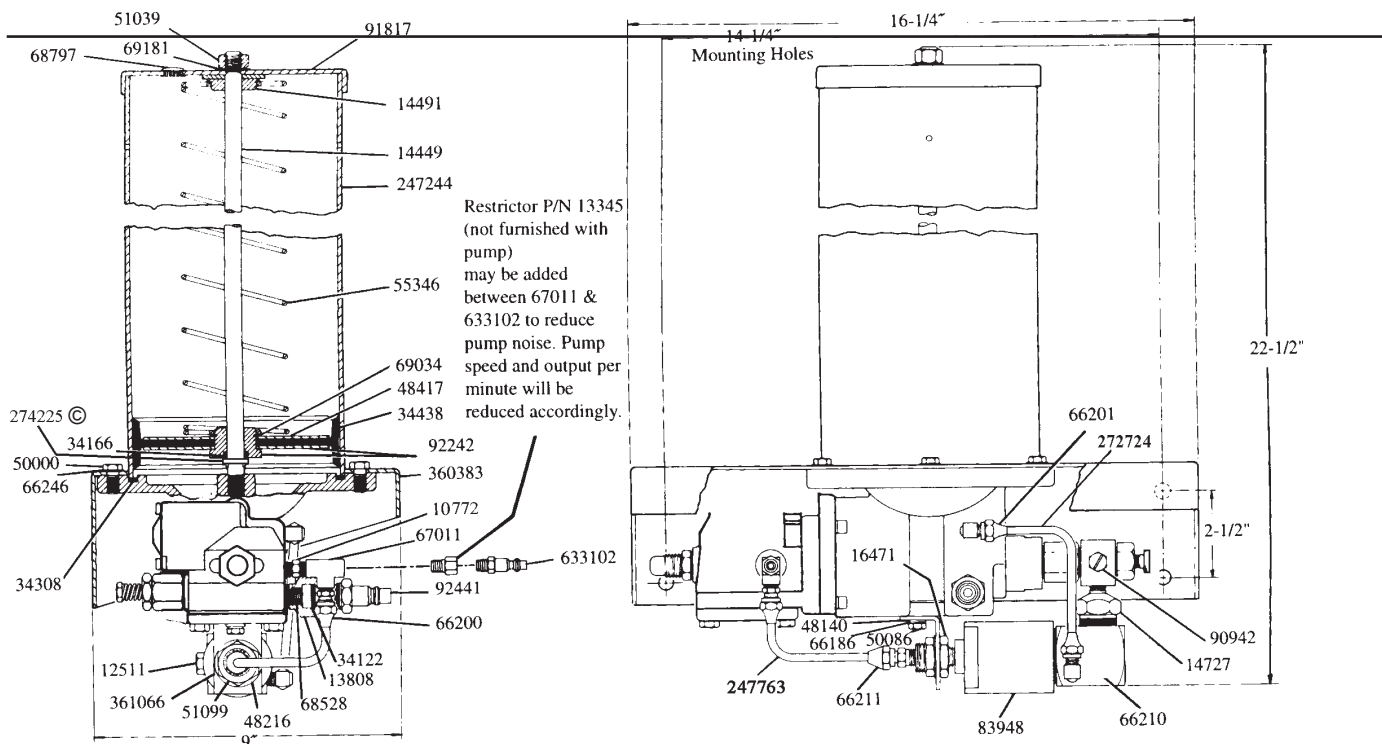

Restrictor P/N 13345 (not furnished with pump) may be added between 67011 & 633102 to reduce pump noise. Pump speed and output per minute will be reduced accordingly.

### SERVICE PARTS

Part	Qty.	Description	Part	Qty.	Description	Part	Qty.	Description
#*10061	1	Pump check disc	#*34158	1	Gasket (Neoprene)	68797	1	Plug button
10127	1	Plug	34166	1	O-ring (Nitrile)	69034	1	Retaining ring
10772	1	Nipple	*34229	1	Packing (Nitrile)	69181	1	Lockwasher
11470	1	Cap	34308	1	Gasket (Nitrile)	#*83063	1	Valve slide, seat & gasket assembly
#*11471	1	Trip rod collar	#*34314	1	O-ring (Nitrile)	83948	1	Vent valve assembly
#*11472	1	Trip rod pin	34438	1	Follower	84508	1	Bushing, plunger & O-ring assembly
#*11475	1	Trip shoe	#*38162	1	Valve gasket (Nitrile)	#*90770	1	Trip rod
11904	1	Packing nut	40821	1	Base casting	*90942	1	Safety unloader
11905	1	Packing cap	#*45605	1	Valve guide plate	#*91331S	1	Toggle plate
#*11947	1	Trip sleeve	48140	1	Washer	91817	1	Reservoir cap
12093	1	Check housing	48212	2	Washer	92242	1	Bushing & washer assembly
12094	1	Air piston bolt	48216	1	Washer	92441	1	Filler fitting
12095	1	Outlet body	48237	1	Washer	236286	1	Cover
12096	1	Outlet block	48417	1	Follower washer	236615	1	Muffler cover
12511	2	Pipe plug	50000	6	Screw	#*236616	1	Gasket
12834	1	Spring retainer	50086	1	Bolt	236833	1	Muffler
13808	1	Adapter	50521	4	Screw	#*236835	1	Packing (Nitrile)
14449	1	Tie rod	51039	1	Nut	236868	4	Screw
14491	1	Retainer washer	51099	1	Nut	236869	6	Screw
14720	1	Air cylinder	55138	4	Spring	236870	4	Valve seat bolt
14721	1	Piston	55231	1	Spring	237562	1	Air valve casting
*14722	1	Needle	55346	1	Follower spring	239330	1	Viton packing assembly
*14723	1	Valve seat	#56003	1	Spring	239336	1	Valve body
14727	1	Reducer nipple	#56038	2	Spring	#*244313	1	Seat
16471	1	Support adapter	66002	1	Steel ball	#*244359	1	O-ring (Nitrile)
#30003	1	Gasket	#*66010	2	Steel ball	#*245425	1	Trip rod packing nut
#*31007	2	Gasket	66186	1	Lockwasher	#246816	1	Gasket
31047	2	Gasket	66200	1	Straight tube connector	247244	1	Reservoir (acrylic)
31054	1	Gasket	66201	1	90 degree tube connector	#247611	1	Gasket
#31056	1	Gasket (Nitrile coated fiber)	66210	1	90 degree tube connector	247763	1	Nylon tubing
#*33039	1	Gasket (Nitrile)	66211	1	Straight tube connector	272724	1	Nylon tubing
34090	1	Packing (Nitrile)	66246	6	Lockwasher	360383	1	Base
#34110	1	Packing (Nitrile)	67011	1	Tee	361066	1	Bracket
*34122	1	Check disc packing	68528	1	Strainer	633102	1	Plug
274225©	1	Retaining Ring						

© Indicates Change

\*Recommended Service Parts Inventory.

#Included in 246415 repair kit.



---

## INSTRUCTIONS FOR PUMP USING 85209 CONTROL PANEL

### TO PRIME SYSTEM

#### SUPPLY LINES:

After pump reservoir has been filled with recommended lubricant, loosen all plugs in dead ends of injector manifolds and supply lines. Turn vent plug in pump counter-clockwise one complete turn. Depress manual lube pushbutton on door to start pump. Operate pump until lubricant bleeds around vent plug to expel air pockets trapped between the pump and the supply line connection. Tighten vent plug. Continue operating pump until lubricant flows around any plug. Tighten plug. Repeat this procedure until all plug openings are tight and supply lines are primed. Turn off power to reset controller.

#### IMPORTANT:

Refer to Owner/Operator Manual C8 259 to program controller on 85209.

#### FEEDER LINES:

Fill each feed line with lubricant before connecting lines to outlets of injectors and bearings. This will prevent having to cycle each injector to fill the feed line between injector and bearing.

#### INJECTORS:

Check the injectors for proper operation by observing the movement of the indicator stems.

#### OPERATION:

When model 85530 times out it will initiate a lube cycle. The air solenoid is energized to deliver air to the pump and air to the vent valve. Pump begins dispensing lubricant through injectors to the bearings.

When all bearings have received lubricant, pressure rises in system to actuate pressure switch. When pressure switch actuates, the control is reset to de-energize solenoid valve cutting off air to pump and vent valve. Pump stops, pressure vents and pressure switch de-actuates. Control begins timing toward next lube event.

---

## INSTRUCTIONS FOR PUMP USING 83820 TIME CONTROL

### TO PRIME SYSTEM

#### SUPPLY LINES:

After pump reservoir has been filled with recommended lubricant, loosen all plugs in dead ends of injectors manifolds and supply lines. Turn vent plug in pump counter-clockwise one complete turn. Set the delay relay to its maximum position (Refer to Service Manual Section C8, Page 133 Series). Depress push button on top of time control to start pump. Operate pump until lubricant bleeds around vent plug to expel air pockets trapped between the pump and the supply line connection. Tighten vent plug. Continue operating pump until lubricant flows around any plug. Tighten plug. Repeat this procedure until all plug openings are tight and supply lines are primed. Open line switch to shut off pump.

#### IMPORTANT:

Reset the delay relay to desired interval (Refer to System Planning Manual).

#### FEEDER LINES:

Fill each line with lubricant before connecting lines to outlets of injectors and bearings. This will prevent having to cycle each injector to fill the feed line between injector and bearing.

#### INJECTORS:

Check injectors for proper operation by observing the movement of the indicator stems.

### OPERATION

The timer (runs constantly when current is on), drives a cam which has lobes set for the desired lubrication cycle frequency (Refer to Service Manual Section C8, Page 133 Series). Lobes engage the micro-switch lever arm to activate the switch, closing the circuit to open the 3-way solenoid air valve permitting air to operate the pump. The pump discharges lubricant through the supply line to the injectors. After the injectors operate (discharge lubricant to the bearings), pump continues to build up lubricant pressure in the supply line until sufficient to operate the pressure control which moves a switch plate, breaking the circuit to the 3-way, solenoid air valve, shutting off the air to the pump. Injectors automatically, re-charge with lubricant and system is ready for the next lubrication cycle.

The pressure control is factory set for 2,500 psi, adequate for any normal installation. If higher pressure is necessary (2,900 psi maximum), the pressure control can be reset;

- 1) Loosen locknut.
  - 2) Turn the housing clockwise into the pressure control body until proper pressure is obtained.
  - 3) Tighten locknut.
- To lower pressure (1,500 psi minimum);
- 1) Loose locknut.
  - 2) Turn the housing counter-clockwise into the pressure control body until proper pressure is obtained.
  - 3) Tighten locknut.

#### VENT VALVE:

The 83948 Vent Valve is operated by compressed air from the same source which operates the pump. When pump is in operation, air pressure keeps the vent valve closed and lubricant is directed through the outlet and to the injectors. When air to the pump is shut off, vent valve opens and supply line pressure vents back into the reservoir.

#### SAFETY UNLOADER:

90942 Safety unloader is provided at the pump outlet to prevent the build-up of dangerously high lubricant pressure in the system. It is factory set to open at approximately 3,750 psi to 4,250 psi.

**NOTE:** Safety unloader requires no adjustment and should not be tampered with.

### WHAT TO DO IF:

Pump loses prime: Check lubricant supply.

10127 Vent Plug is provided at the pump outlet for expelling air which may be pocketed in the lubricant. If pump operated continuously without discharging lubricant, it is an indication that the pump has lost its prime. Loosen the vent plug one turn until trapped air is pumped out. If pump continues to operate without discharging lubricant, 10061 Pump Check and 66002 Steel Ball may be fouled. Remove and clean checks and check seats. The 83948 Vent Valve may also be fouled. Foreign material may prevent 14722 Needle from seating properly, or 14723 Valve Seat may be worn or damaged. Clean or replace parts.

Failure of injectors to cycle can also be caused by a leak in the supply line. Examine lines and connections.

Pump fails to operate: Check air supply.

---

### RETAIN THIS INFORMATION FOR FUTURE REFERENCE

When ordering replacement parts, list: Part Number, Description, Model Number and Series Letter.

LINCOLN provides a Distributor Network that stocks equipment and replacement parts.