

System Description

Microlok[®] II

Integrated Vital Interlocking, Coded Track Circuit, and Non-vital Code Line Controller

THIS DOCUMENT AND ITS CONTENTS ARE THE PROPERTY OF UNION SWITCH & SIGNAL INC. (HEREINAFTER US&S[®]) FURNISHED TO YOU ON THE FOLLOWING CONDITIONS: NO RIGHT OR LICENSE IN RESPECT TO THIS DOCUMENT OR ITS CONTENTS IS GIVEN OR WAIVED IN SUPPLYING THE DOCUMENT TO YOU. THIS DOCUMENT OR ITS CONTENTS ARE NOT TO BE USED OR TREATED IN ANY MANNER INCONSISTENT WITH THE RIGHTS OF US&S AND ARE NOT TO BE COPIED, REPRODUCED, DISCLOSED TO OTHERS OR DISPOSED OF EXCEPT WITH THE PRIOR WRITTEN CONSENT OF US&S.

NOTE

This manual displays the most recent revision number for its information.

Manuals distributed with revision number 2.1 or lower (or without a revision number) do not contain the most up-to-date Microlok II information.

REVISION INDEX

Revised pages of this manual are listed by page number and date of revision. On the revised page, a vertical bar in the margin denotes revised material.

Page Number	Revision Date
2-12	09-00
2-14	09-00
2-17	09-00
2-18	09-00
2-20	09-00
3-10	09-00
3-12	09-00
2-10	01-04

CONTENTS

1.	GENERAL INFORMATION.....	1-1
1.1	R.A.I.L. Team and Technical Support.....	1-1
2.	SYSTEM DESCRIPTION.....	2-1
2.1	General Application and Functions	2-1
2.2	Basic Hardware/Software Elements	2-2
2.2.1	System Cardfile.....	2-2
2.2.2	Vital Cut-Off Relay.....	2-2
2.2.3	Commercial Power Monitoring.....	2-2
2.2.4	Coded Track Circuit and Cab Signal Interfaces.....	2-2
2.2.5	Circuit Isolation/Protection	2-3
2.3	Microlok II Applications.....	2-4
2.3.1	Basic Interlocking Control (Figure 2-1).....	2-4
2.3.2	Coded Track Circuit Control (Figure 2-2)	2-6
2.3.3	Cab Signal Carrier/Code Generation and Track Circuit Overlay (Figure 2-3).....	2-8
2.3.4	CPU Serial Communications (Figure 2-4)	2-10
2.3.5	Non-Vital Code System Interface (Figure 2-4)	2-10
2.3.6	Non-Vital Parallel I/O Interfaces and Local Control Panel (Figure 2-5)	2-12
2.4	Overview of Operating Software and Software Handling.....	2-14
2.5	System Cardfile Description	2-15
2.5.1	General Configuration (Figure 2-6)	2-15
2.5.2	General Functions and Designs of Plug-In Components.....	2-17
2.5.3	Power Supply Board and System Power Configuration (Figure 2-25).....	2-38
2.6	Microlok II Auxiliary Equipment Descriptions	2-45
2.6.1	Coded Track Interface Panels (Figure 2-26).....	2-45
2.6.2	Quick Shunt Module	2-46
2.6.3	Cab Signal Interface Panels (Figure 2-27)	2-46
2.6.4	Isolation Module	2-48
2.6.5	VCOR Relay	2-48
2.6.6	Serial Communications Adapter Panel.....	2-48
3.	SYSTEM SPECIFICATIONS	3-1
3.1	System Operating Power	3-1
3.2	Vital Input and Output Printed Circuit Boards.....	3-2

3.2.1	Power Characteristics.....	3-2
3.2.2	Vital Data I/O Characteristics	3-3
3.3	Non-Vital I/O Printed Circuit BoardS Power and Data I/O	3-4
3.4	OS Track Circuit Communications	3-4
3.5	Coded Track Circuit Communications.....	3-5
3.5.1	Coded Track Circuit PCB Applications and Operating Power	3-5
3.5.2	Coded Track Interface Panel Applications	3-5
3.5.3	Track Circuit Length.....	3-6
3.5.4	Track Codes.....	3-6
3.6	Cab Signal Generation.....	3-7
3.6.1	Cab Signal Interface Panel Applications.....	3-7
3.6.2	Code Rates and Carrier Frequencies	3-7
3.6.3	Battery Current Draw and Rail Current	3-7
3.7	CPU Printed circuit board.....	3-8
3.7.1	Microprocessor	3-8
3.7.2	Executive and Application EPROMs.....	3-8
3.7.3	RAM (Vital Data Processing and Event/Error Logs).....	3-9
3.7.4	Serial Communications Ports.....	3-9
3.8	Code System Interface Printed Circuit Board.....	3-10
3.8.1	Available Code System Applications.....	3-10
3.8.2	Microprocessor and Associated Memory.....	3-10
3.8.3	Serial Communications Ports.....	3-10
3.9	System Cardfile Hardware Configuration.....	3-11
3.10	Miscellaneous Peripheral Equipment	3-12
3.10.1	VCOR Relay	3-12
3.10.2	Power-Off Relay	3-12
3.10.3	Isolation Module	3-12
3.10.4	Non-Vital Serial Link Isolator Unit	3-12
3.10.5	Serial Communications Adapter Panel.....	3-12
3.11	Environmental	3-13

1. GENERAL INFORMATION

This manual provides the following information on the Microlok[®] II system:

- System-level application and operational descriptions
- Application and design technical specifications
- System-specific configurations
- System level and component specifications

Related manuals covering the Microlok II system include:

- SM-6800B - Microlok II System Hardware Installation Manual
- SM-6800C - Microlok II System Startup, Troubleshooting, and Maintenance
- SM-6800D - Microlok II System Application Logic Programming

Other manuals that provide information on related systems include:

- SM-6700A – GENISYS[®]-2000 Multi-Purpose Non-vital Control/Communications System (Application Logic Programming)
- SM-6470A - MicroTrax[®] Coded Track Circuit System Application Logic Programming
- SM-6470B - MicroTrax Coded Track Circuit/End-of-Siding Controller/Cab Signal Controller (Hardware Installation and Configuration)
- SM-6700B - GENISYS-2000 Multi-Purpose Non-vital Control/Communications System (Hardware Installation and Configuration)

1.1 R.A.I.L. TEAM AND TECHNICAL SUPPORT

The Rapid Action Information Link (R.A.I.L.) team was created in 1996 to serve the technical needs of current and potential US&S customers. Convenient 24-hour access and a rapid resolution to customer problems are the trademarks of this organization. The R.A.I.L. team, which is staffed primarily by US&S product and application engineers, is ready to assist and resolve any technical issues concerning the Microlok II system or any other US&S product.

Any questions regarding the contents of this service manual should be directed to the R.A.I.L. team by telephone at 1-800-652-7276 or through Internet E-mail at railteam@switch.com.





2. SYSTEM DESCRIPTION

2.1 GENERAL APPLICATION AND FUNCTIONS

The Microlok II interlocking control system is a multi-purpose monitoring and control system for railroad and rail mass transit wayside interlocking equipment. Basic applications and uses of the Microlok II system include:

- Direct control of wayside signals (color light signal lamps and searchlight signal mechanisms)
- Switch machine control and switch point position monitoring
- Switch lock position monitoring
- Monitoring of mainline track circuits for track occupancy indications and track circuit problems such as faulty insulated joint or broken rail
- Through-the-rails communications to adjacent wayside control systems
- Monitoring of interlocking OS track circuits
- Cab signal carrier/code generation
- Line wire communications interface
- Local manual control of wayside signals and switch machines for maintenance and contingency operations
- Vital serial communications to other compatible interlocking control and coded track circuit systems
- Non-vital controller logic
- Non-vital (code line) communications to remote office

The Microlok II system implements these functions in any combination, from basic to complex through the use of application-specific hardware configurations. The modular design of the Microlok II system enables each customer to custom-configure a system that will meet the specific control and interface requirements for the intended application. The operational configuration of the Microlok II system is primarily defined within the application logic software, which is custom-developed using the Microlok II programming tools.

2.2 BASIC HARDWARE/SOFTWARE ELEMENTS

The basic hardware and software elements of the Microlok II system include:

2.2.1 System Cardfile

- Vital CPU for overall system monitoring, control, diagnostics and data recording.
- Executive and application logic for vital interlocking functions.
- Executive and application logic for non-vital control/communication functions.
- Vital output channels for switch machines, searchlight mechanisms, and signal lamps.
- Vital input channels for switch correspondence and searchlight mechanism position.
- Non-vital I/O channels for local control panel (LCP) non-vital controls and indications.
- Vital serial data I/O channels for communication with remote systems.
- Non-vital serial I/O channels for non-vital code line communications.
- Serial I/O channel for application logic and executive software loading and upgrades.
- User controls/displays for on-site system configuration and access to diagnostic codes.
- Cab signal carrier-generation and coding circuits for code overlay on track circuits.
- On-unit local control panel.

2.2.2 Vital Cut-Off Relay

Provides CPU-controlled switching of battery power to vital output circuits.

2.2.3 Commercial Power Monitoring

A power-off relay provides a non-vital indication of commercial power failure to the Microlok II system.

2.2.4 Coded Track Circuit and Cab Signal Interfaces

- Interface panels for coded track circuit signal reception and output of track codes to rails.
- Interface panels for cab signal outputs at various carrier frequencies.
- Quick shunt module for minimized coded track detection response time.

2.2.5 Circuit Isolation/Protection

- Isolation module for double-break type vital output circuit isolation.
- Surge suppression/isolation units for non-vital serial communication lines.
- Serial communications adapter panel for protection of vital serial links to remote houses.

2.3 MICROLOK II APPLICATIONS

As discussed in the preceding section, the Microlok II system hardware and software can be easily configured for a number of interlocking through applications. Sections 2.3.1 - 2.3.6 that follow provide details on the Microlok II system configuration for each application type.

2.3.1 Basic Interlocking Control (Figure 2-1)

The Microlok II system provides control and monitoring functions for all elements of basic railway vital interlocking. Supervision and control of switch machines, switch locks, signal lamps, searchlight signal mechanisms, and line wire communication circuits are managed by the vital microprocessor on the system cardfile CPU board. Standard vital output boards interface discrete commands from the CPU board to switch machine relays or other types of vital relays as required. Non-vital bi-polar output boards interface CPU commands to searchlight signal mechanisms and any other equipment requiring a non-vital bi-polar voltage output. Vital lamp driver boards enable direct lighting of color light and searchlight signal lamps. Vital input boards interface various external circuit inputs back to the CPU board. Typical vital inputs include searchlight mechanism position, switch machine correspondence, and interlocking OS track circuit occupancies. The Microlok II system is also capable of interfacing with coded track circuits adjacent to the controlled interlocking.

OS track circuit occupancy detection is accomplished using a dedicated OS track circuit board in the system cardfile. This board, which is designed for single end-of-siding interlockings, incorporates a single OS frequency transmitter (400 Hz) and two receivers. OS track circuit occupancies are reported to the cardfile CPU through a vital input printed circuit board.

Devices included with the system that augment the basic Microlok II interlocking control function include a vital cut-off relay (VCOR) and an isolation module. The VCOR contacts control the supply of battery power to all cardfile vital outputs, such as switch machine relays and signal lamps. The VCOR relay is controlled by the cardfile CPU board microprocessor, which performs constant diagnostics on Microlok II internal circuits and external circuit interfaces. These diagnostics include monitoring of all individual vital output and inputs channels at the point of interface with external circuits. The microprocessor responds to failure of a safety-critical diagnostic by commanding the cardfile Power Supply board to remove the dc supply to the VCOR coil. This drops the VCOR and opens the contacts that provide battery power to the vital output boards. This fail-safe function defaults the interlocking equipment associated with the Microlok II system to the most restrictive state.

The Microlok II isolation module provides the equivalent of double-break circuit protection when the system is controlling vital relays or interfacing with line circuits in a separate equipment house or case. This unit, which eliminates the need for an equivalent isolation board in the cardfile, is connected to an output from the cardfile standard vital output board or mixed vital I/O board. The isolation module is also capable of converting a uni-polar output from the standard vital output board to a bi-polar output.

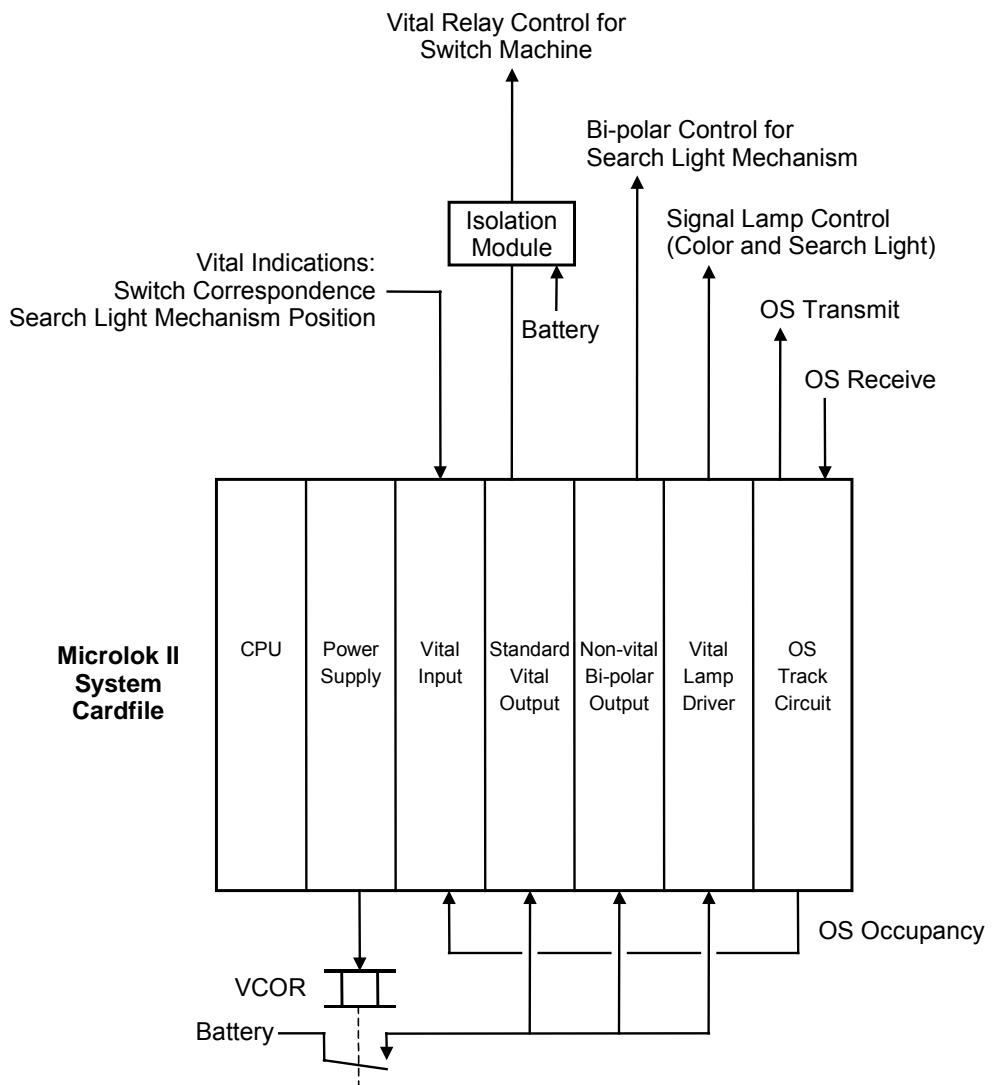
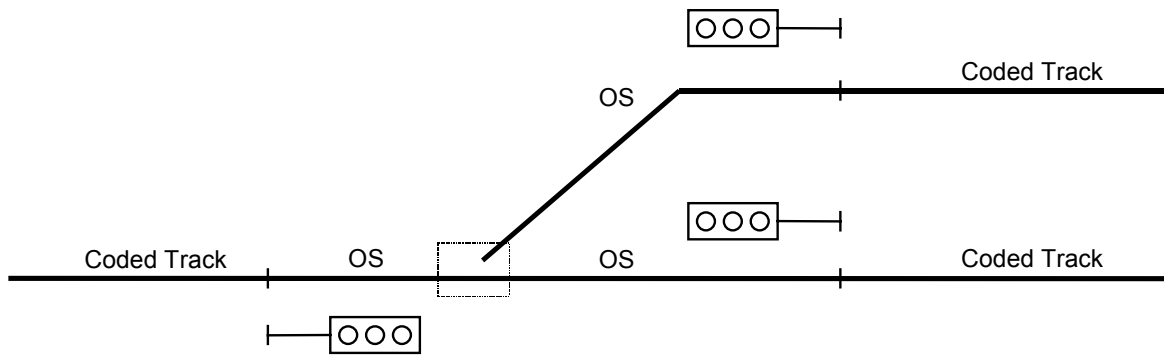

Figure 2-1. Microlok II System Configuration for Basic Interlocking Control

2.3.2 Coded Track Circuit Control (Figure 2-2)

The basic Microlok II interlocking control function can include an integral coded track circuit subsystem or an interface to an existing coded track circuit system. The Microlok II equipment used in the system for this configuration includes a coded track circuit printed circuit board in the system cardfile, a coded track interface panel between the cardfile and the track, and an optional quick shunt module wired in conjunction with the track panel. These three devices are also used in the US&S MicroTrax[®] coded track circuit system.

The coded track circuit printed circuit board provides an interface between the CPU board vital microprocessor and the actual track circuits on the approaches to the interlocking. The CPU monitors incoming coded track circuit communications through the coded track circuit printed circuit board, and interprets a loss of communications (due to shunting of the signal by an approaching train) as a track occupancy condition (train detection). Four coded track circuits can be monitored at the same time. The Microlok II CPU board processes the occupancy inputs in the context of the entire interlocking control scheme.

Loss of coded track communications or irregular communications can also be interpreted as a broken rail or faulty insulated joint condition. In these instances, the system responds in the same manner as a shunt condition. Different versions of the coded track circuit printed circuit board are available to accommodate standard non-cab territory applications, and territories carrying cab signal frequencies (see section 2.3.3). Coded track circuit communications initiated by the vital CPU are also interfaced through the coded track circuit printed circuit board to the rails. Up to 22 user-defined track codes are provided for standard line circuit functions such as clear block.

The coded track interface panel terminates the track at very low impedance to the frequency components of the track code. This feature enables the use of maximum length track circuits, and ensures that the coded track subsystem is compatible with wide-band terminating shunts. A high impedance is also created at 150 Hz and higher frequencies. This ensures compatibility with highway crossing motion and predictor equipment without the need for external blocking units. Four versions of the coded track interface panel are available for use with the Microlok II system. Three of these panels are designed for operation with different cab signal carrier frequencies (where present).

The optional quick shunt module is provided for Microlok II coded track circuit applications with heavy traffic and close headways. This unit is designed to reduce the nominal 8- to 12-second shunt response time to approximately 1/4 second.

The Microlok II system can be interfaced with existing MicroTrax coded track circuit systems as an independent source of coded track communications and control. A vital serial data link between the Microlok II CPU board and the remote MicroTrax unit transmits train detection indications and outgoing track codes between the two control units. The typical application for this configuration is the siding track of an end-of-siding interlocking. In this configuration, the Microlok II system controls the main line approaches while the MicroTrax system controls the siding track.

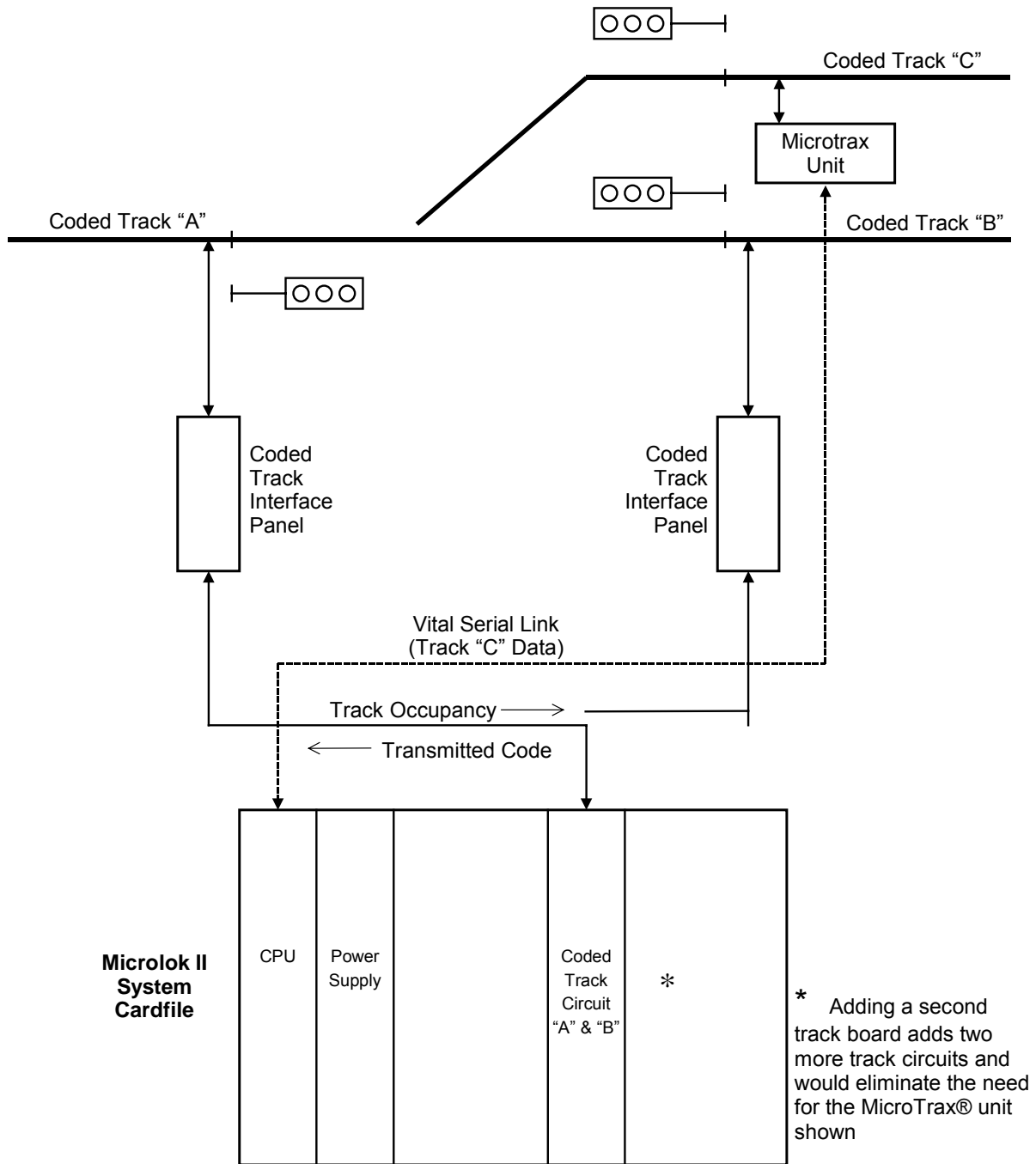

Figure 2-2. Microlok II Coded Track Circuit Configuration

2.3.3 Cab Signal Carrier/Code Generation and Track Circuit Overlay (Figure 2-3)

The Microlok II system can be configured to produce standard or customized cab signal carrier frequencies and code rates for overlay on the interlocking track circuits. System components provided for this application include the coder output and cab amplifier printed circuit boards in the system cardfile, and cab signal interface panels that connect the cab signals to the tracks. These circuit boards and interface panels are also used in the US&S MicroTrax[®] coded track circuit system.

The Microlok II coder output printed circuit board produces standard cab signal code rates of 75, 120, and 180 CPM and is controlled by the CPU board. An auxiliary coder output circuit board that produces two 50 CPM outputs for special applications is also available. The Microlok II CPU does not control this board. The cab amplifier printed circuit board produces cab signal carrier frequencies of 60 or 100 Hz (manually selected). This board operates in conjunction with the coder output printed circuit board, but is not directly controlled by the vital CPU. An auxiliary 40/50 Hz cab amplifier printed circuit board is available for special applications.

Three different cab signal interface panels are available to interface the system-generated cab signals with the rails for overlay on coded track circuit signals. Each configuration of the interface panel accommodates a different cab signal carrier frequency, including the typical 60 and 100 Hz carriers, and a 40 Hz carrier for special applications. The cab signal interface panels limit harmonics that could disrupt highway motion detectors and crossing predictors. Unwanted side-band frequencies are minimized through the use of special carrier switching and carrier cycle numbering schemes.

The interface panel is equipped with adjustments for rail current (both sides of insulated joint) and fine calibration of carrier frequencies. Panel protective features include current limiting when a train is directly over the track connections and built-in filtering to prevent cab transmitter interference with coded track messages.

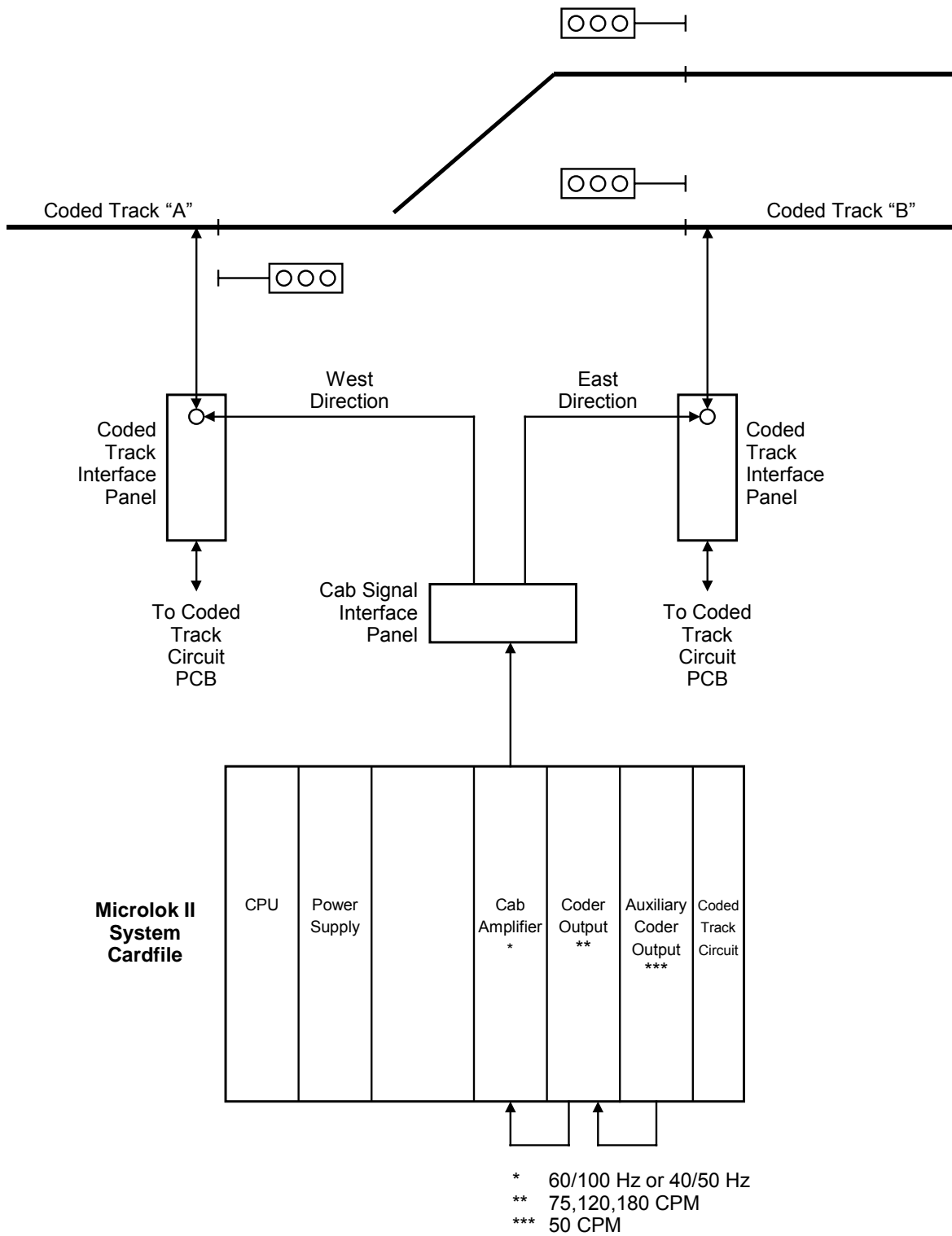

Figure 2-3. Microlok II Cab Signal Configuration

2.3.4 CPU Serial Communications (Figure 2-4)

The Microlok II CPU board design incorporates four serial I/O data ports that provide communication with other control systems. The two EIA RS-485-compatible ports are typically used for communication with vital controllers such as another Microlok II system, a Microlok system, or one of the US&S MicroTrax systems. The two EIA RS-232/423-compatible ports are typically used for communication with various non-vital code systems such as the US&S GENISYS-2000 controller. These particular ports are also utilized when a serial link is needed for the Microlok II code system interface board (see section 2.3.5). Selection and configuration of these serial ports is handled entirely in the Microlok II application software.

Microlok II vital serial communications are supported with the US&S serial communications adapter panel. This device is employed when a Microlok II system must communicate with another system in a different equipment house or case. The panel converts serial link EIA signals to 20 ma current loop levels. This impedes external voltage transients corrupting the serial communication signals between the houses.

2.3.5 Non-Vital Code System Interface (Figure 2-4)

The Microlok II system can be configured to manage communications with a remote non-vital code system. This code system would in turn handle interlocking communications with a central control office. For most code system applications, this is accomplished with a code system interface printed circuit board installed in the Microlok II system cardfile, and a serial isolator unit connected into the serial communication lines. The code system interface printed circuit board is functionally identical to the enhanced controller printed circuit board used in US&S GENISYS-2000 systems.

Code system interfaces that are supported by the Microlok II design include:

- Allen Bradley DF1
- ARES
- ATS/PTS
- GRS Datatrain II
- GRS Datatrain VIII
- Harmon MCS-1
- US&S GENISYS
- US&S GENISYS Dual Slave
- US&S GENISYS Dual Ind. Slave
- WB&S S2

Interfaces to dc code lines (US&S 500 series and GRS K series) are not directly supported by the Microlok II system cardfile; an external GENISYS 2000 unit is needed to provide this type of interface.

Microlok II communications with US&S GENISYS or GENISYS-2000 equipment (or other equipment incorporating GENISYS or GENISYS-2000 code system protocols) can be accomplished directly through the Microlok II CPU board, or using a code system interface printed circuit board. When the CPU board is used to manage the interface, the CPU's application logic software is programmed to support the required GENISYS or GENISYS-2000 interface. In addition, one of the CPU board's four serial I/O ports is used for the link to the remote GENISYS-based system.

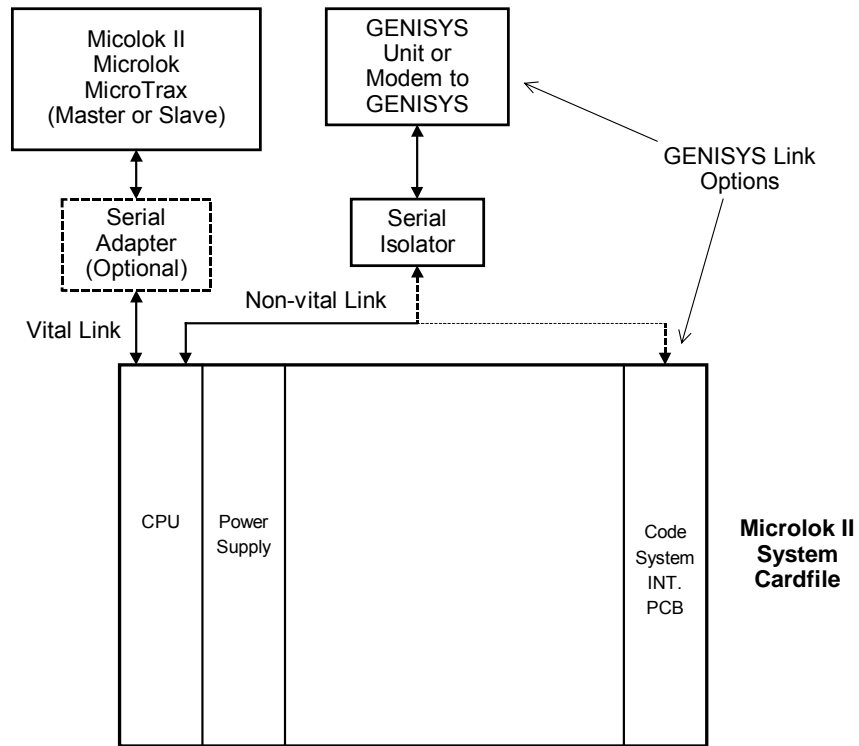

CPU Board Interfaces

Code System PCB Interfaces

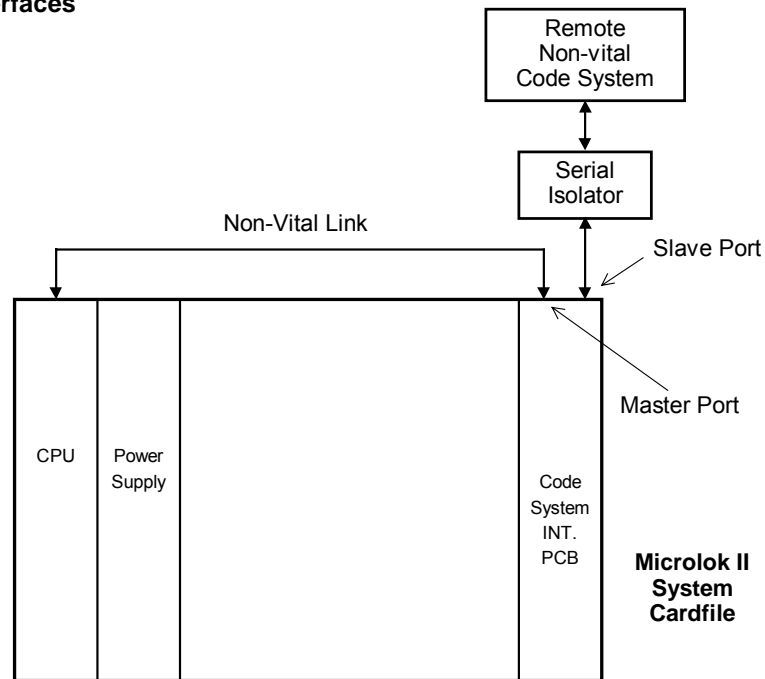

Figure 2-4. Microlok II Vital and Non-Vital Serial Communications

When the code system interface board is used to manage this interface, the GENISYS or GENISYS-2000 interface software is programmed into the board's own application EPROM. In this configuration, a serial link on the system cardfile connects the CPU board and the code system interface board. The code system interface board is not linked to the CPU board through the system cardfile backplane bus.

Microlok II communications with non-GENISYS-based code systems require the code system interface board in all instances. Specific executive EPROMs are provided for the board to accommodate all code system applications (GENISYS and non-GENISYS).

The Microlok II serial link isolator unit provides transient/surge voltage protection on the non-vital serial code lines for both the Microlok II system and the code system circuits. Two versions of this device are available for ATCS-based and non-ATCS type code systems.

The code system interface board has no provisions for non-vital local I/O (parallel) communications.

2.3.6 Non-Vital Parallel I/O Interfaces and Local Control Panel (Figure 2-5)

The Microlok II System includes components for controlling and monitoring local non-vital circuits and devices. Two non-vital I/O boards are provided; one for general non-vital circuit applications and another for general non-vital circuits/devices and an optional on-unit local control panel (LCP). The Microlok II CPU board controls both types of non-vital I/O boards through the system cardfile bus. Non-vital inputs (LCP toggle switch changes, for example) are passed to the CPU board for processing through the bus, while non-vital outputs (power to light an LCP indicator or an external indicator lamp) are controlled by the CPU through the bus.

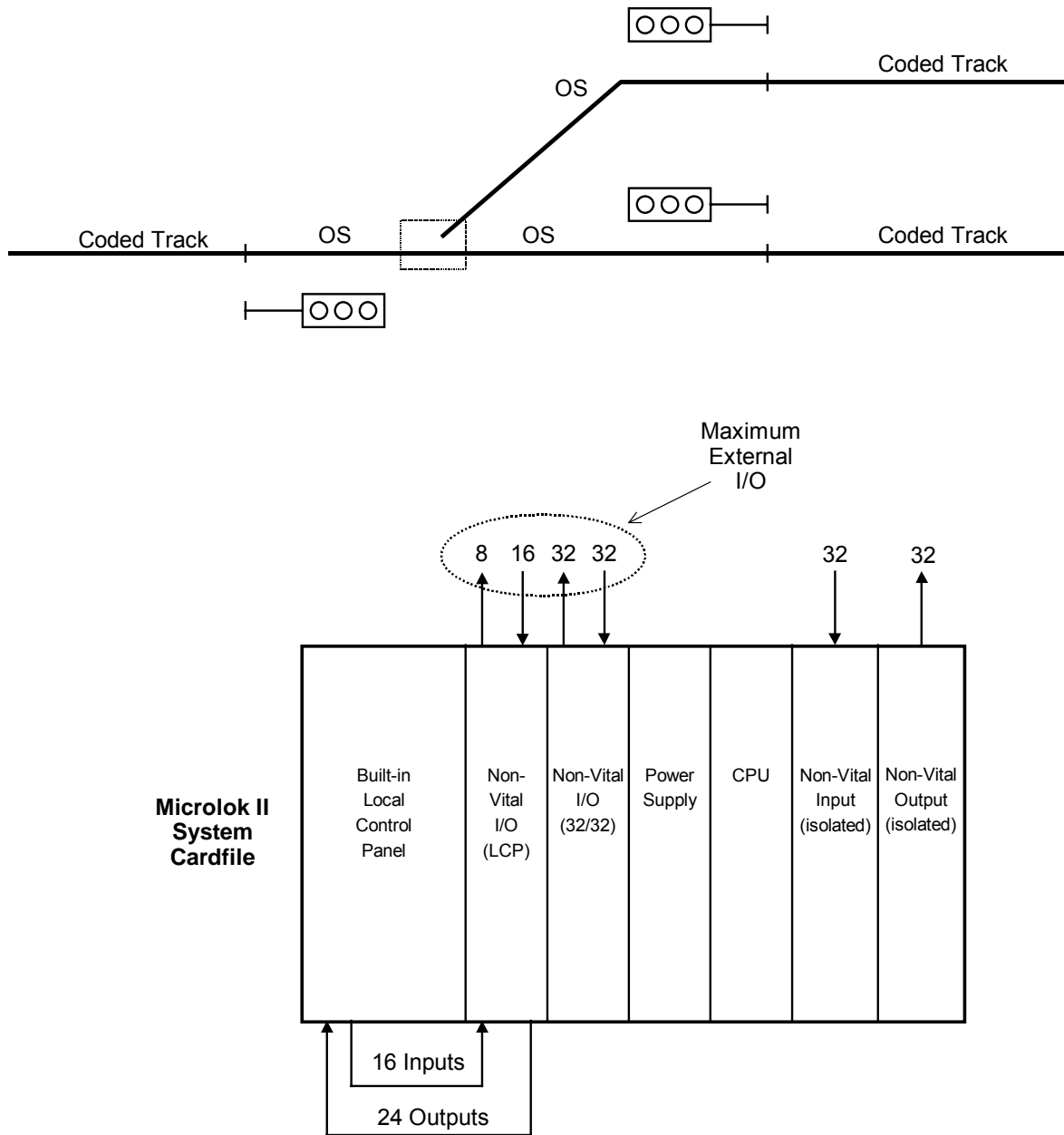

Figure 2-5. Microlok II Non-Vital I/O Interfaces (Including LCP)

2.4 OVERVIEW OF OPERATING SOFTWARE AND SOFTWARE HANDLING

Depending on the system application, the Microlok II system cardfile can contain up to five different software elements. All Microlok II systems contain vital executive and application software on the CPU board. Systems that use the code system interface board also contain non-vital executive and application software on that board. In addition, an EEPROM, located on the CPUU board edge connector housing, is programmed with site-specific configuration data that is unique to the cardfile.

The executive software is standard for all Microlok II systems (US&S-developed) and is responsible for the overall vital monitoring and control of the system. The responsibilities of the executive software include:

- Interlocking vital input monitoring, decision making and commands.
- Monitoring of all vital input and output channels for intended on/off states.
- Processing of user inputs received from a laptop PC or the CPU board front panel.
- Continuous internal and external diagnostics.
- Recording and playback of routine event and error codes.
- Recording and playback of user-specified events.
- Management of the serial data ports.
- Execution of the application software.

All Microlok II CPU boards are shipped with the executive software already loaded into memory. Version upgrades are downloaded to the CPU using a laptop PC connected to a serial data port on the CPU board front panel. US&S supplies its own Windows[®]-based programming interface, the Microlok II Maintenance Tools program, for this purpose.

The vital application software contains the application-specific logic (user-developed) appropriate for the overall Microlok II system configuration. Generally, the user develops this software using the same US&S programming tools used for executive software version upgrades. Refer to service manual SM-6800D for detailed information on Microlok II application software programming.

Site-specific configuration data stored in the CPU board edge connector housing EEPROM can be loaded using the CPU board front panel toggle switches and LED displays, or with the laptop PC connection to the CPU board front panel serial port. The PC-based method controls a greater range of configuration options.

2.5 SYSTEM CARDFILE DESCRIPTION

2.5.1 General Configuration (Figure 2-6)

The Microlok II system cardfile contains the system's central controlling logic and circuits that interface this logic directly to external circuits or intermediate units (Microlok II track interface panels, for example). Logic and interface circuits are contained on the familiar Eurocard format plug-in printed circuit boards. The system cardfile contains 20 card slots, although not all slots will be used in every application. Each installed circuit board plugs into a common backplane motherboard. The backplane distributes circuit board operating power and enables the CPU board to control and monitor other boards in the cardfile.

The specific circuit boards used in each Microlok II system are determined entirely by the system application, although typical configurations are recommended to optimize available cardfile space. No particular slot is restricted to a particular board, however the code system interface printed circuit board (when used) is typically placed in the far right slot (slot 20) because of its non-standard front panel width. In addition, the board configuration must agree with the configuration defined in the application logic software.

To prevent accidental insertion of a board in the wrong cardfile slot, each board is equipped with male keying pins. These pins correspond with keying plugs installed in the associated backplane slot connector. The keying pins are installed in the field once the board configuration is determined. Several other restrictions are placed on the installation of the non-vital I/O printed circuit boards and the local control panel. Refer to service manual SM-6800B for specific board installation rules. In order to allow communications between the CPU board and the other boards in the cardfile, each board must have its bus address configured in hardware. This is accomplished by means of a set of six two-position jumpers, mounted at the rear of the cardfile in the external cable/connector housing attached to the top connector of each board. Jumper settings are defined in the application software.

Not all Microlok system cardfile boards communicate directly with the CPU board through the cardfile backplane. Certain boards interface to other board which, in turn, communicates with the CPU. The following table summarizes the communication path used by each circuit board:

Board Type	CPU Controlled	Comments
Vital/non-vital output	✓	Standard vital output and non-vital bi-polar output
Vital input	✓	--
Vital lamp driver	✓	--
Mixed vital I/O	✓	Combination of standard vital output and vital input
Non-vital I/O	✓	--
Coded track circuit	✓	--
Coder output	✓	--
Code system interface		Serial link cabled to CPU on rear of cardfile
Cab amplifier		Interfaces to coder output printed circuit board
OS track circuit		Interfaces to vital input Printed Circuit Board
Power Supply		Receives power-off signal from CPU if a fault is detected.

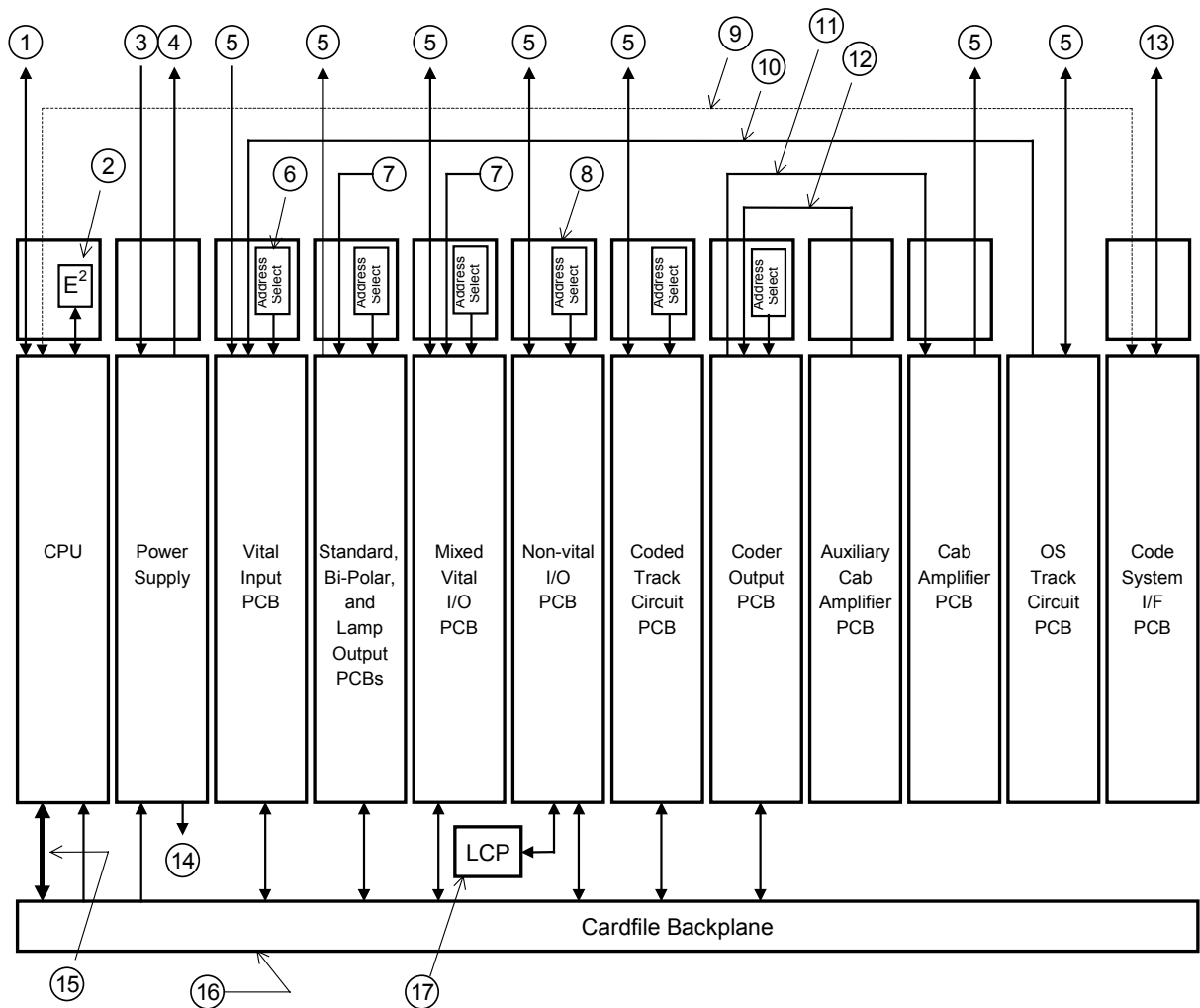

- ① Vital or non-vital CPU serial interface to external system (when required by application).
- ② System EEPROM: Stores unit-specific configuration data.
- ③ Signal battery: 9.5 Vdc to 16.5 Vdc.
- ④ VCOR pick energy (under control of CPU).
- ⑤ Miscellaneous vital I/O external circuits.
- ⑥ Address Select Board for setting PCB slot address.
- ⑦ Vital output power controlled through VCOR contacts.
- ⑧ 48-pin or 96-pin connector housing.
- ⑨ CPU non-vital serial link with code system I/F PCB (when required by application).
- ⑩ OS track occupancy indication to vital input PCB.
- ⑪ Cab signal 75, 120, 180 code output to cab amplifier PCB.
- ⑫ Auxiliary 50 code to augment 75, 120, 180 code (when required by application).
- ⑬ Code system I/F PCB non-vital interface to external code system.
- ⑭ PCB +5V, +12V operating power to all boards via backplane.
- ⑮ CPU address, data and control lines to applicable PCBs under control.
- ⑯ Carries CPU-controlled communications with applicable I/O boards.
- ⑰ LCP interface to non-vital I/O PCB N17000601 only.

Figure 2-6. System Cardfile Functional Configuration

2.5.2 General Functions and Designs of Plug-In Components

2.5.2.1 CPU Board (Figures 2-7 and 2-8)

The same CPU board is used in all Microlok II applications. The general functions of this board include:

- Monitoring external indications from vital input boards, coded track circuit boards, non-vital input boards, and the code system interface board.
- Processing vital external indications and executing logic defined in the application software.
- Driving vital output boards (standard, lamp driver, coded track, cab signal) as required by the application program.
- Monitoring and controlling serial communication ports (links to other controllers).
- Testing individual vital input and output channels for faults (in parallel with control of these channels) and responding to detected faults.
- Monitoring system internal operation for faults and responding to detected faults.
- Controlling power to vital outputs through the cardfile power supply and an external VCOR relay (fail-safe function).
- Recording system faults and routine events in user-accessible memory.
- Responding to CPU board front panel switch inputs and operating the associated displays.
- Interacting with a laptop PC during system diagnostic operations, application logic programming, and executive software upgrading.

The CPU board is controlled by a 68332 microprocessor, which operates at a speed of 21 MHz, and includes 2K bytes of internal fast termination RAM. Most internal operations are 32 bits wide, while all outside bus cycles are 16 or 8 bits wide. An independent 2 MHz Enable-Clock line is provided to operate older 6800 style peripheral devices.

The executive and application software is stored in four flash EPROMs that provide up to 8 megabytes of memory. Flash EPROMs permit direct handling of the software using a laptop PC connected to the CPU board front panel serial port connector. Jumpers are provided on the board to enable or disable the flash EPROMs for programming and to select the required programming voltage.

Two independent banks (128 Kbytes total) of fast static RAM (SRAM) are provided on the CPU board for processing vital data. Events and errors are stored in up to four 256 Kbyte banks of low power SRAM. Error/event memory is maintained by a capacitor backup that provides up to four hours of short-term RAM protection. The CPU is also designed to store read/write data in

one of two optional PCMCIA card slots, using a board-mounted cardholder. This additional memory is used to increase the on-board event recording capability.

The CPU board uses a Real Time Clock based on a 32.768 oscillator. The same capacitor and external lithium battery used for the fast SRAM back up this device.

The CPU board incorporates five serial data ports, four of which are intended for communications with external vital and non-vital systems. The remaining port interfaces communications with a PC connected to the board's front panel 9-pin connector.

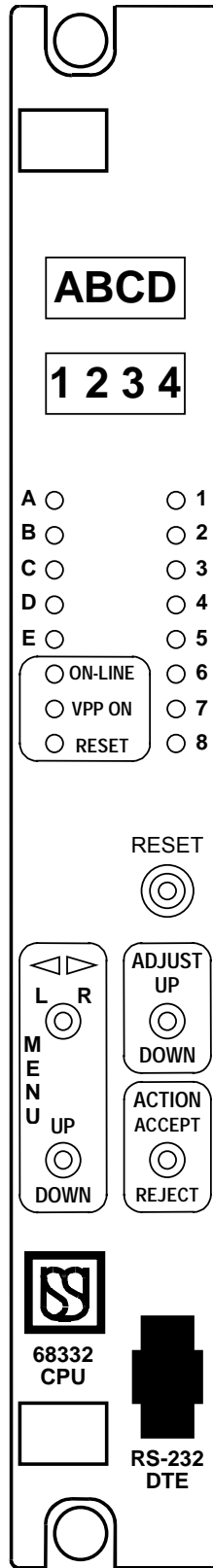

Figure 2-7. CPU Board Front Panel Layout

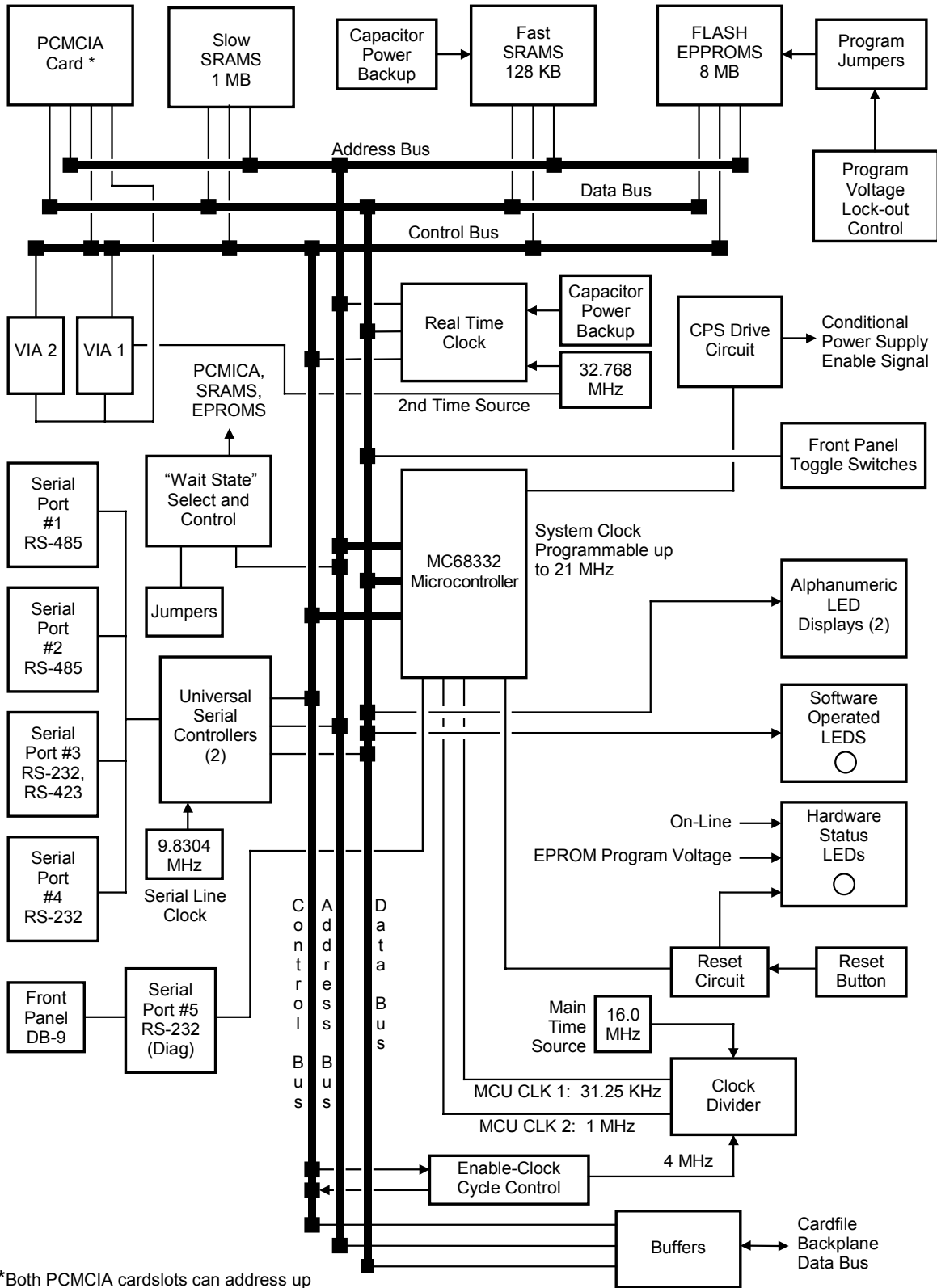

Figure 2-8. CPU Board Functional Diagram

2.5.2.2 Standard Vital Output Printed Circuit Boards (Figures 2-9 and 2-10)

The Microlok II standard vital output boards (part numbers N17060501 (12V) and N17060502 (24V)) interface CPU vital outputs to external relay coils and similar loads. Both boards provide 16 independent outputs; the 01 board handles nominal 12V outputs, while the 02 board handles nominal 24V outputs. Outputs are controlled by “high side” software-controlled switches that connect battery positive to the output. Each output is also protected with a polyswitch, a device that functions like a circuit breaker. When the overcurrent trip point (about 0.75 amp) is exceeded, the device switches to high impedance. The polyswitch returns to low impedance when the overload or short circuit condition is removed. A short to battery negative trips the affected polyswitch. This results in the dropout of the VCOR relay, thus protecting all vital output circuits associated with the system. The system responds to a short to battery positive in the same manner as a false output. This condition also results in the dropout of the VCOR relay.

Refer to section 3.2 for the standard vital output board operating specifications

2.5.2.3 Non-vital Bi-Polar Output Printed Circuit Board (Figures 2-11 and 2-12)

The non-vital bi-polar output board (N17061801) enables the Microlok II system to drive bi-polar outputs such as searchlight signal mechanisms. This board provides 12 independent outputs which change polarity under the control of 24 paired virtual outputs. Alternate assertion of a virtual pair changes the actual output. Two-color LEDs on the board’s front panel are used to indicate when the actual output is on, with green or yellow indicating the polarity. (Yellow indicates normal polarity, and green indicates reverse polarity.) If neither pair is asserted, the output is off and both LEDs are dark.

Outputs on this board are protected from accidental connection to B12 or N12. Short circuit protection is also provided. If both virtual outputs of a pair are asserted, an error will be logged in the CPU event memory and the output will remain off.

Refer to section 3.3 for non-vital bi-polar output board operating specifications.

2.5.2.4 Mixed Vital I/O Printed Circuit Boards (Figure 2-12)

The mixed vital I/O boards (part numbers N17061601 (low voltage) and N17061602 (high voltage) provide the same type of output channels as the standard vital output board, and the same type of input channels as the vital input board. This board is intended for smaller scale Microlok II applications that do not require a full 16 channels on a single board. Eight output and eight input channels are included. The use of a mixed vital I/O board eliminates the need for separate standard vital output and vital input printed circuit boards.

Refer to section 3.2 for mixed vital I/O board operating specifications.

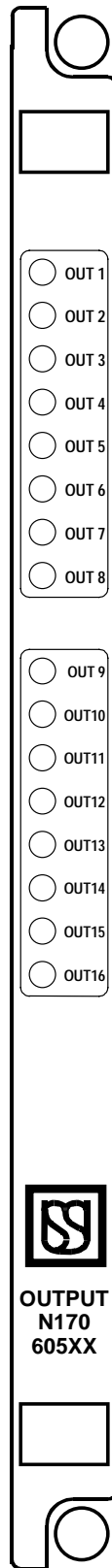

Figure 2-9. Standard Vital Output PCB Front Panel Layout

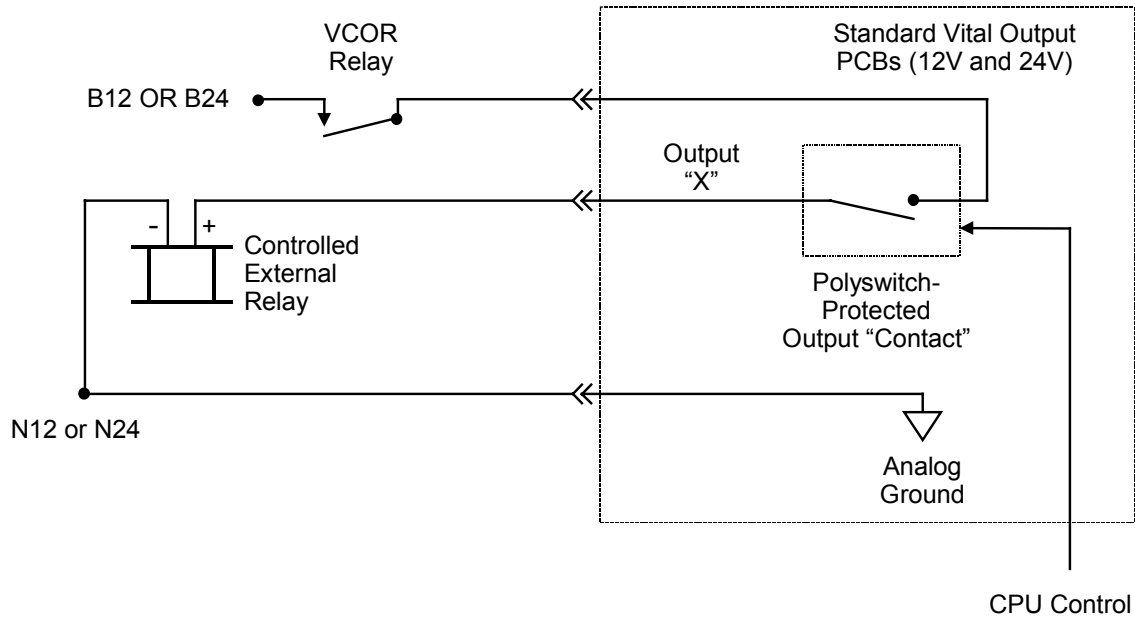

Figure 2-10. Basic Configuration of the Standard Vital Output PCB

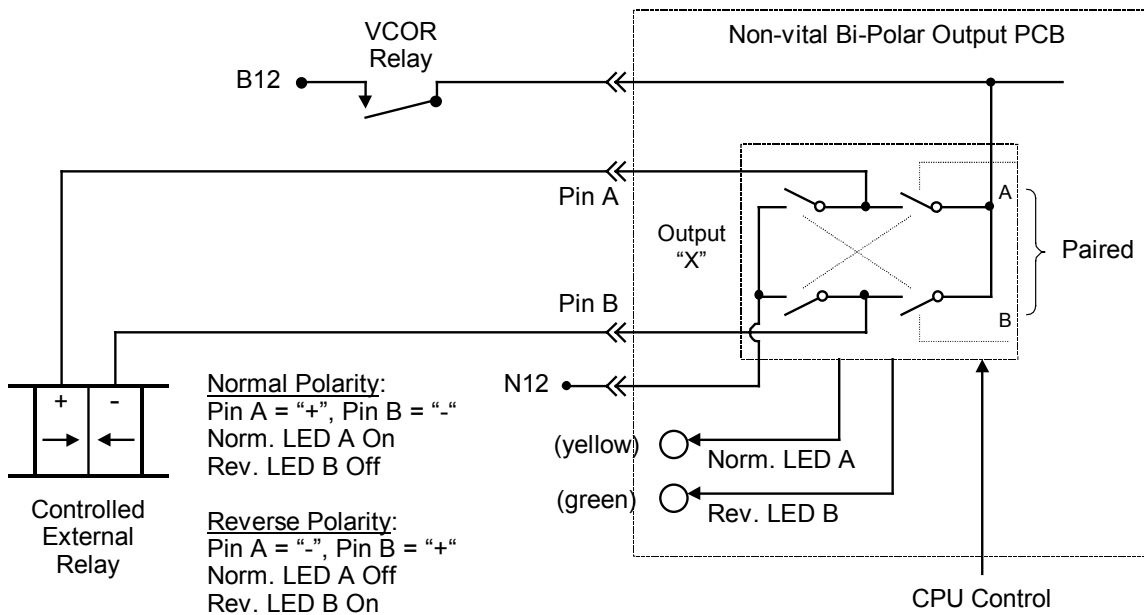

Figure 2-11. Basic Configuration of the Non-vital Bi-Polar Output PCB

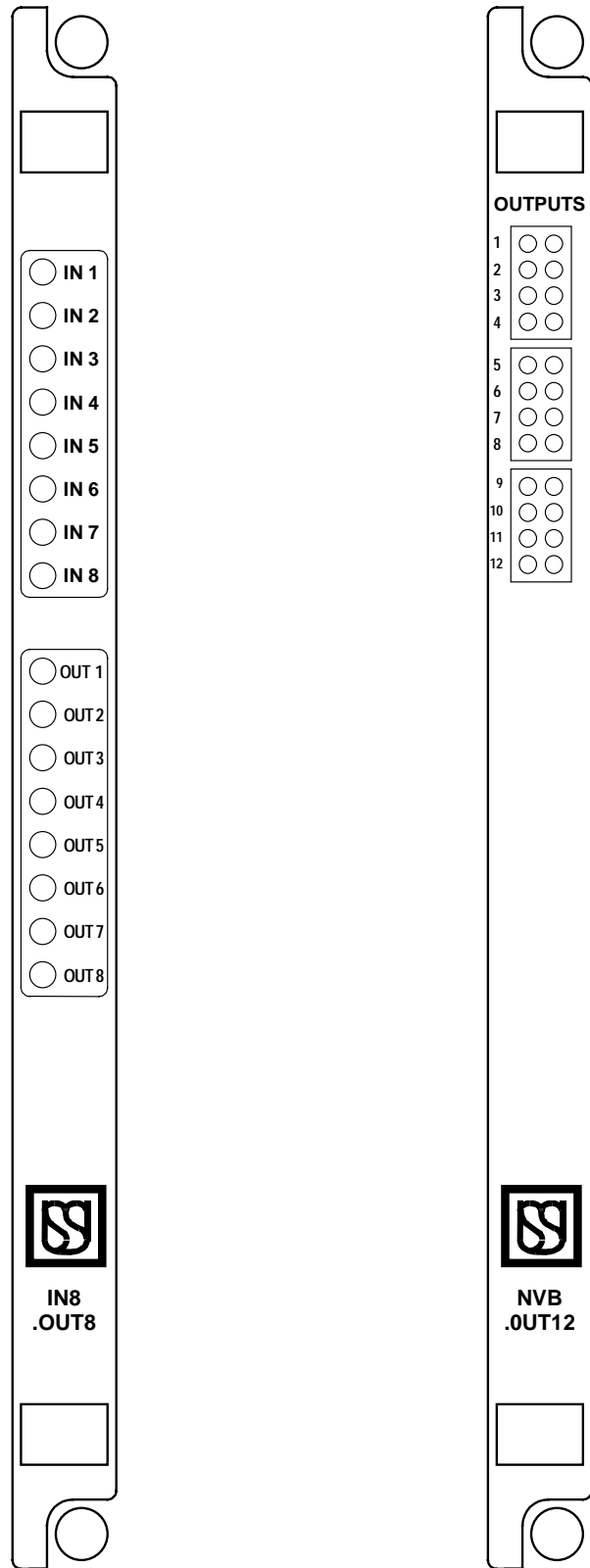

Figure 2-12. Mixed Vital I/O and Non-vital Bi-Polar Output PCBs - Front Panel Layouts

2.5.2.5 Vital Lamp Driver Printed Circuit Board (Figures 2-13 and 2-14)

The vital lamp driver printed circuit board (part number N17060101) enables the Microlok II CPU to directly operate color light and searchlight signal lamps. This board uses 16 outputs to drive up to 8, 12, or 16 signal lamps, depending on the lamp wattage (300W maximum for all lamps). Nominal lamp voltage and wattage configurations are defined using the CPU board front panel switches and displays, or using the Microlok II Maintenance Tools program loaded on a laptop personal computer. The configuration data is stored in the CPU cable mounted EEPROM.

Low side switches on the vital lamp driver board control the individual lamp driver outputs. The low side switch requires connection from the output through a front contact of the external VCOR relay to battery positive. A short from a lamp driver output to battery positive will not cause damage to the circuit. However, the CPU board executes a system shutdown because this type of short circuit would produce a false lighting of the associated signal lamp.

Lamp voltage is adjusted using external variable resistors in the common returns for each signal head. These resistors, typically mounted in the Microlok II equipment rack, protect the lamp board from damage by limiting current in the event of a short circuit outside the equipment house. Voltage on the lamp boards can be increased to up to 18Vdc if required because of long run cables.

Refer to section 3.2 for vital lamp driver board operating specifications.

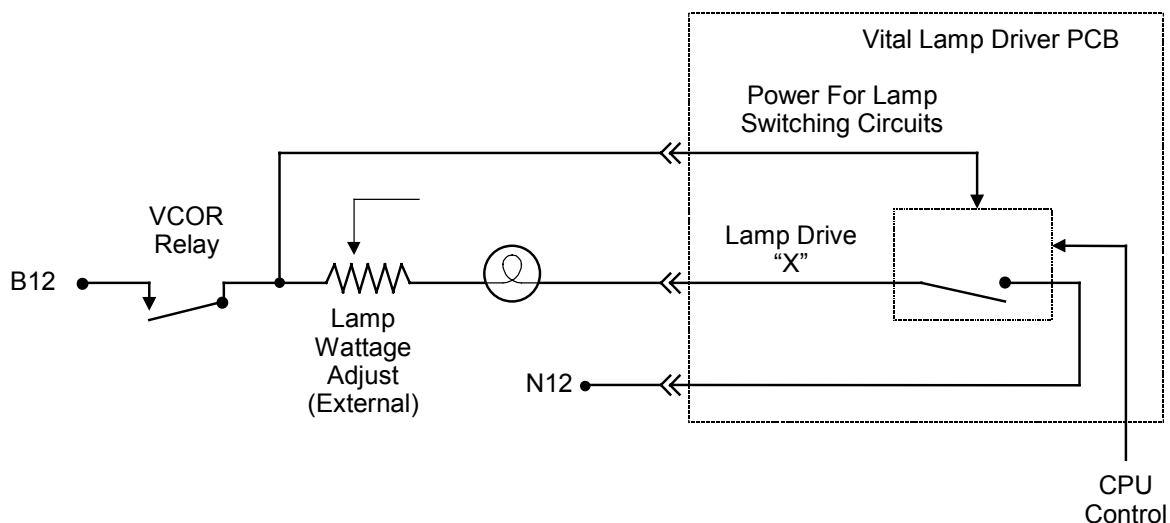

Figure 2-13. Basic Configuration of Vital Lamp Driver Board

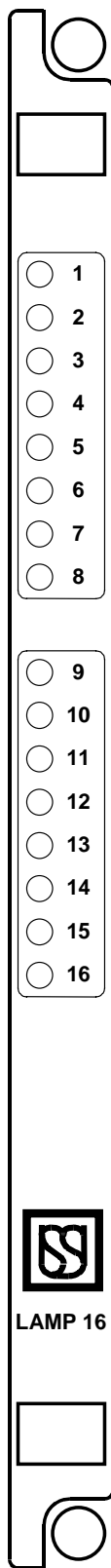

Figure 2-14. Vital Lamp Driver PCB Front Panel Layout

2.5.2.6 Code System Interface Printed Circuit Board (Figures 2-15 and 2-16)

The code system interface printed circuit board (part number N17061401) is used in Microlok II applications that require a non-vital serial communications link to a CTC code system that uses a communication protocol other than GENISYS. The Microlok II CPU board communicates to the code system interface board through a direct serial link that is connected between the two boards.

The code system interface board is functionally identical to the enhanced controller printed circuit board used in the GENISYS Series 2000 systems. The components of the board are, however, rearranged to accommodate the configuration of the Microlok II Eurocard style circuit board. A 16-bit Motorola MC68010 microprocessor controls the board. This chip is driven by a 10 MHz clock signal. Two EPROM ICs contain the board's executive software; two additional EPROMs contain the user-defined application software. Each of these EPROM sets has a storage capacity of 128K bytes. Field-configurable data is stored in a separate, electrically erasable PROM (EEPROM).

The 68010 microprocessor is also supported by two 32K RAM chips for storage of variable data. These devices have a capacity of 64KB x 8 bytes. Two 85C30 serial communications controllers, each equipped with two serial data ports, interface external serial communications with the microprocessor. These ports serve, but are not limited to, the following applications:

- Universal serial port (ATCS, GENISYS, MCS-1, S2, slave port)
- Asynchronous serial port (GENISYS master port)
- Asynchronous serial port (field set-up and diagnostics)
- Asynchronous serial port (spare)

Refer to section 3.5 for code system interface board operating specifications. Refer to service manual SM-6700B for configuration procedures that use the board's front panel controls and displays.

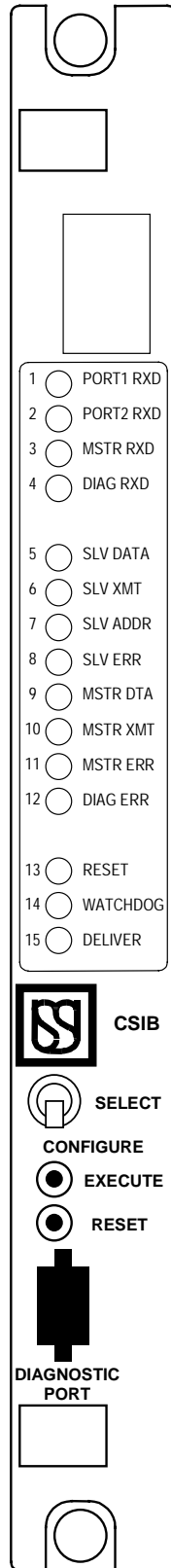

Figure 2-15. Code System Interface PCB - Front Panel Layout

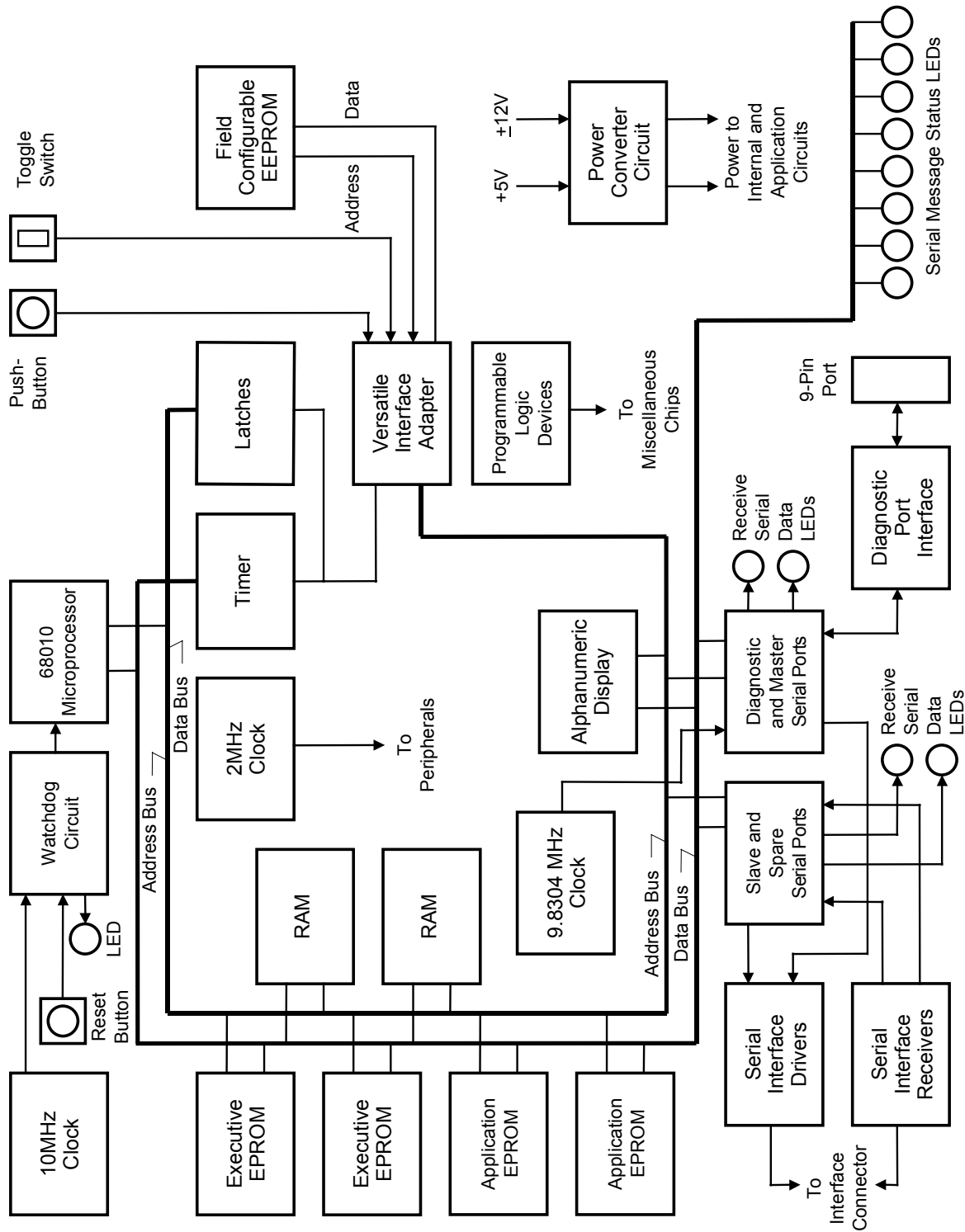

Figure 2-16. Code System Interface Board Functional Diagram

2.5.2.7 Coded Track Circuit Printed Circuit Boards (Figures 2-17 and 2-18)

The coded track circuit printed circuit boards enable the CPU to monitor the track circuits (for track occupancy shunt) on the mainline approaches to the interlocking, and also generate track circuit signals for output into the rails. These boards are identical to those used in US&S MicroTrax systems. Board part numbers and applications include:

US&S Part No.	Application
N451910-0701	General non-cab and 100 Hz cab signal-compatible
N451910-7601	40 Hz cab signal-compatible
N451910-7602	50 Hz cab signal-compatible
N451910-7603	60 Hz cab signal-compatible

Each board is equipped with circuitry for converting CPU board-compatible signals to track-compatible signals and vice-versa. Two separate transmit/receive circuits are included to enable control of two separate coded track circuits. Additional filtering circuitry on the cab-compatible boards is designed to ensure that cab signal carriers do not interfere with the dc track codes.

Refer to section 3.5 for coded track circuit board operating specifications.

2.5.2.8 OS Track Circuit Printed Circuit Board (Figure 2-19)

The OS track circuit printed circuit board (part number N451810-6701) is responsible for generating and monitoring a 400 Hz carrier signal for the interlocking OS tracks, to enable train detection on those tracks. In addition to the 400 Hz transmitter, the board is equipped with two receivers for return reception of the carrier on two interlocking OS tracks (for end-of-siding installation). The OS track circuit board transmits train detection indications to the vital input printed circuit board through hard-wired connections; these signals are not carried over the cardfile bus. In addition, the OS track circuit printed circuit board is not monitored or controlled by the CPU printed circuit board. The board functions in the same manner as an external module that is interfaced to the system cardfile. The OS track circuit printed circuit board is identical to the board used in the MicroTrax coded track circuit/end-of-siding controller.

The OS track circuit printed circuit board is not equipped with cardfile front panel controls or indicators. Refer to section 3.4 for operating specifications.

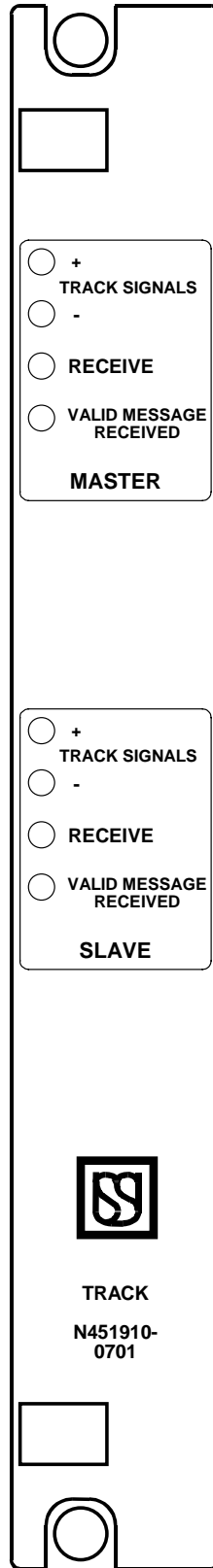

Figure 2-17. Coded Track Circuit PCB - Front Panel Layout

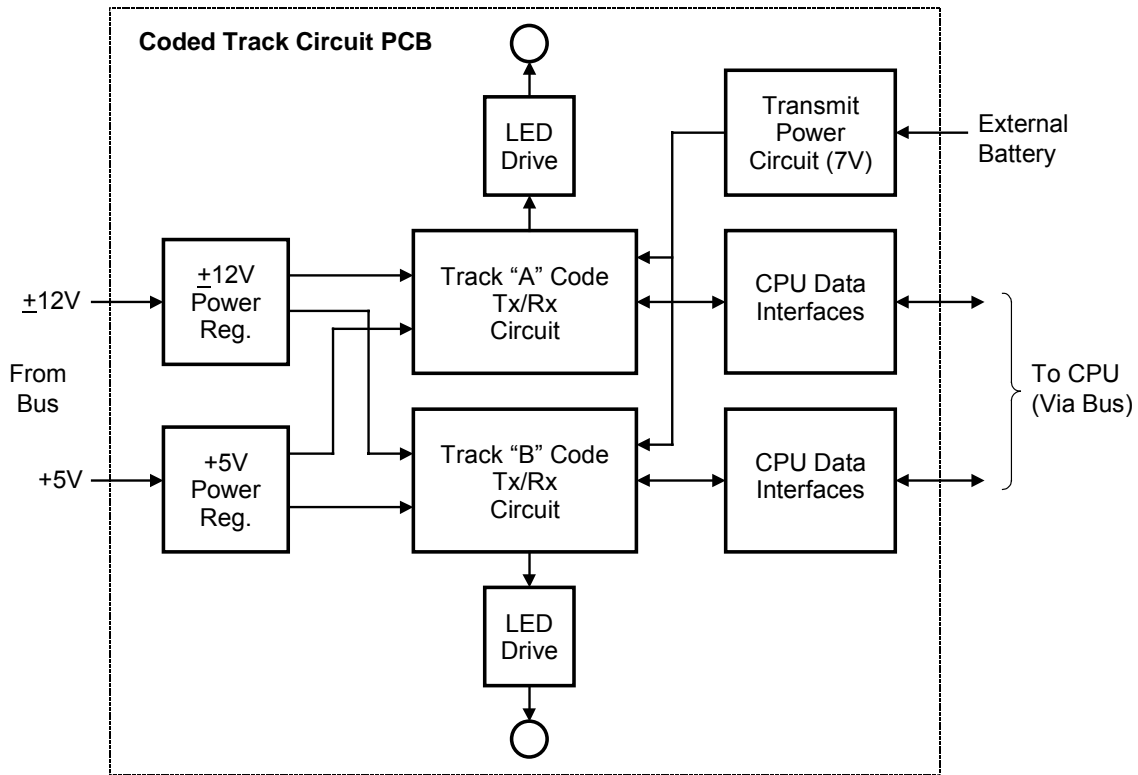

Figure 2-18. Basic Configuration of the Coded Track Circuit PCB

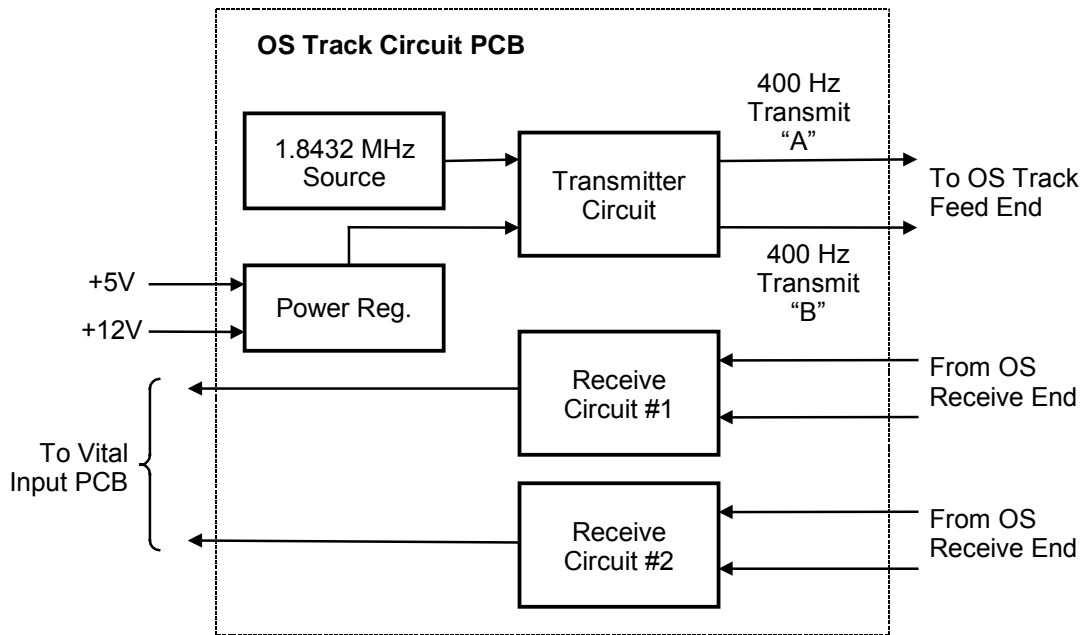

Figure 2-19. Basic Configuration of the OS Track Circuit PCB

2.5.2.9 Coder Output and Auxiliary Coder Output PCBs (Figures 2-20 and 2-21)

The coder output board (N451910-5801) and the auxiliary coder output board (N451910-7001) enable the Microlok II system to generate different cab signal code rates for overlay on the cab signal carrier developed by the cab amplifier printed circuit board. These boards are also used in the US&S MicroTrax systems. Board -5801 contains oscillator circuits that produce standard code rates of 75, 120, and 180 codes per minute (CPM). Field effect transistors (FETs) are used to drive the developed signals. This board is monitored and controlled by the CPU over the system cardfile backplane, and includes two output channels not used in Microlok II applications (limited to MicroTrax applications). Board -7801 is used in special applications that require the output of two independent 50 CPM codes. This board is wired to the -5801 coder output board and is not controlled by the CPU.

In addition to cab signal code generation, the -5801 board is used to set up cab signal rail current in conjunction with jumper adjustments on the associated cab signal interface panel (refer to service manual SM-6800B). A 3-position toggle switch applies constant energy to either side of the track connection.

Refer to section 3.6 for coder output and auxiliary coder output board operating specifications.

2.5.2.10 60/100 Hz and 40/50 Hz Cab Amplifier Printed Circuit Boards (Figure 2-22)

The cab amplifier printed circuit boards produce the required cab signal carrier frequency that carries the code rate developed by the coder output or auxiliary coder output printed circuit boards. Board part number N451910-6401 generates standard carriers of 60 or 100 Hz. Part number N451910-6901 generates a 40 Hz or 50 Hz carrier for special applications. The circuit that develops the basic carrier signal consists of a 1.8432 MHz crystal oscillator, separate divide-by-10 chips for the two frequencies, and a decade counter. FETs drive the carrier signal outputs.

The cab amplifier printed circuit board incorporates a jumper that is used to select the appropriate carrier frequency. Another jumper defines current limiting for short or long track circuits in conjunction with matching adjustments on the associated cab signal interface panel (see service manual SM-6800B).

Refer to section 3.6 for cab amplifier board operating specifications.

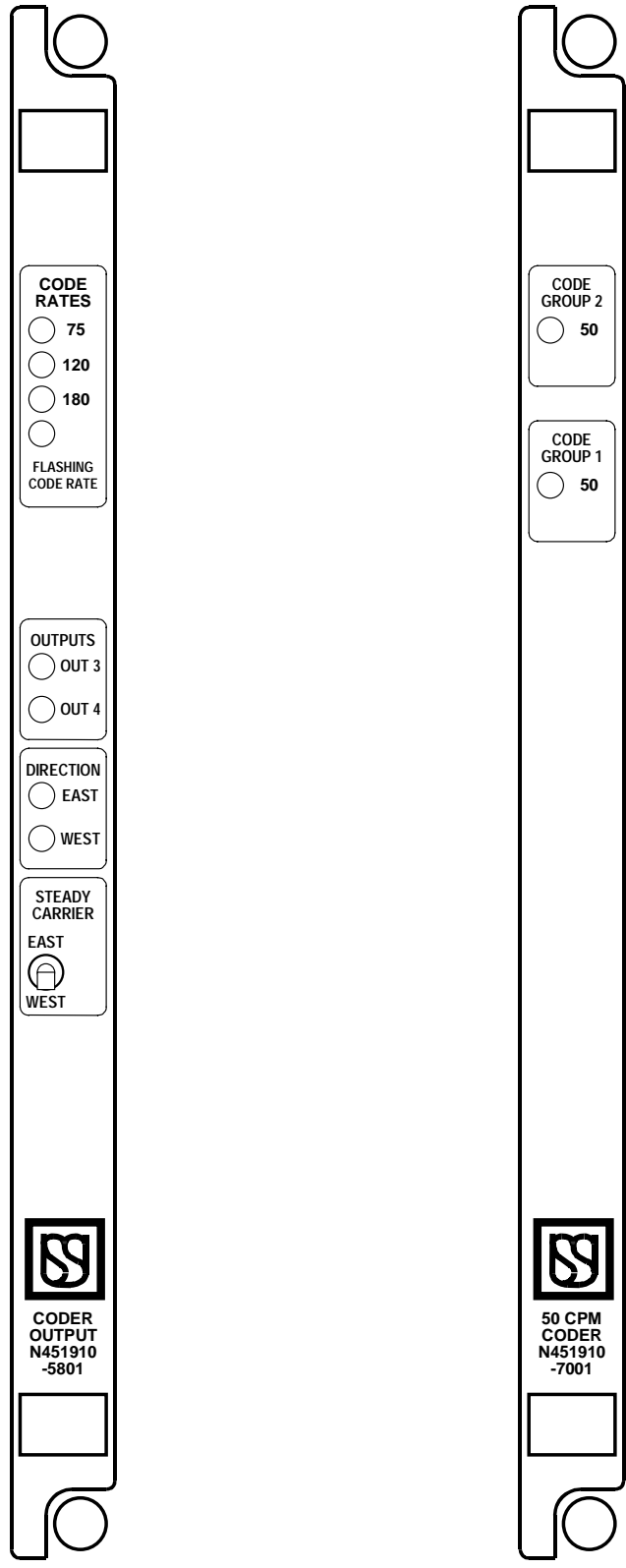

Figure 2-20. Coder/Output PCB and Auxiliary Coder Output PCB - Front Panel Layouts

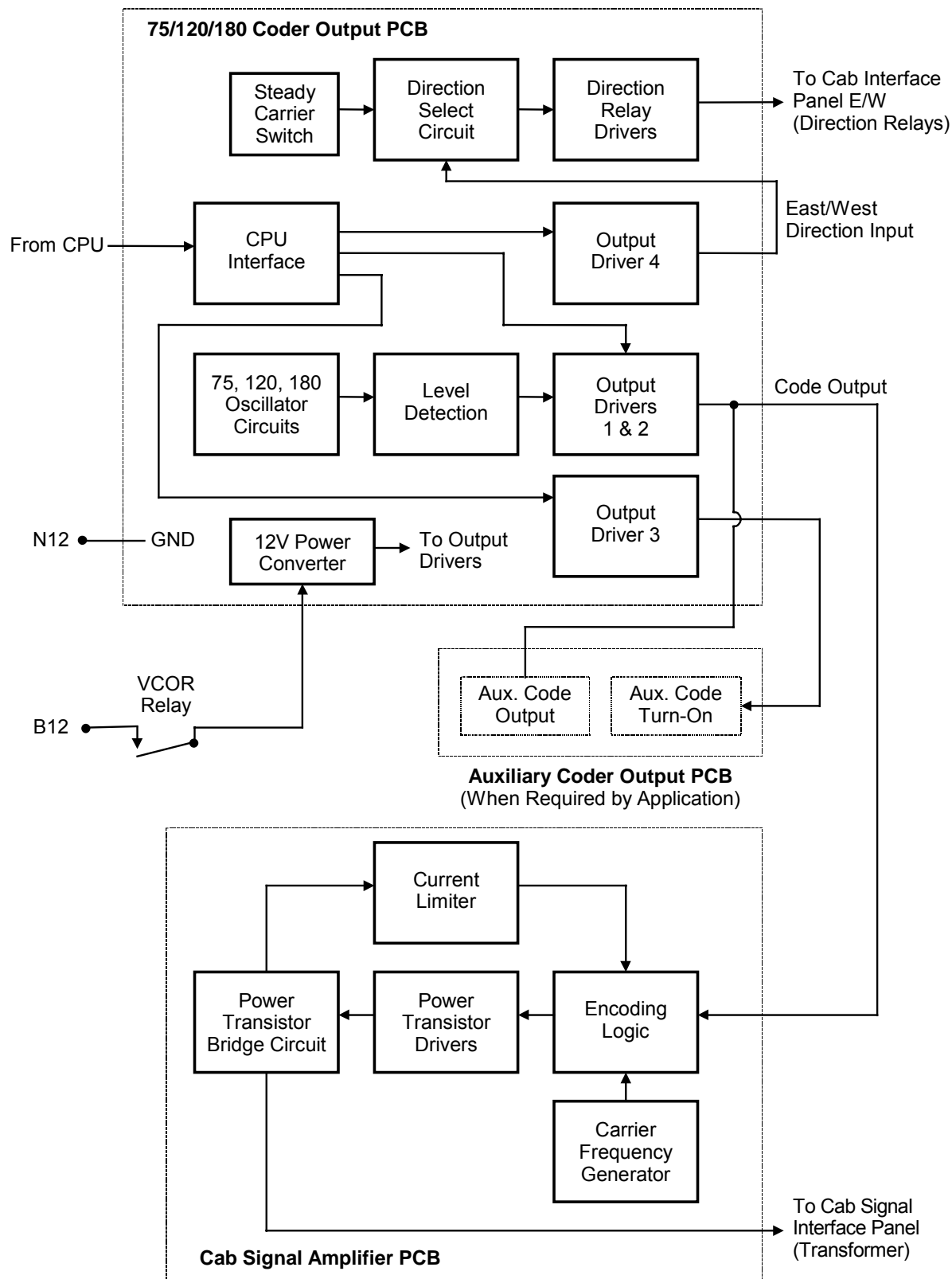

Figure 2-21. Basic Configurations of Coder Output and Cab Amplifier PCBs

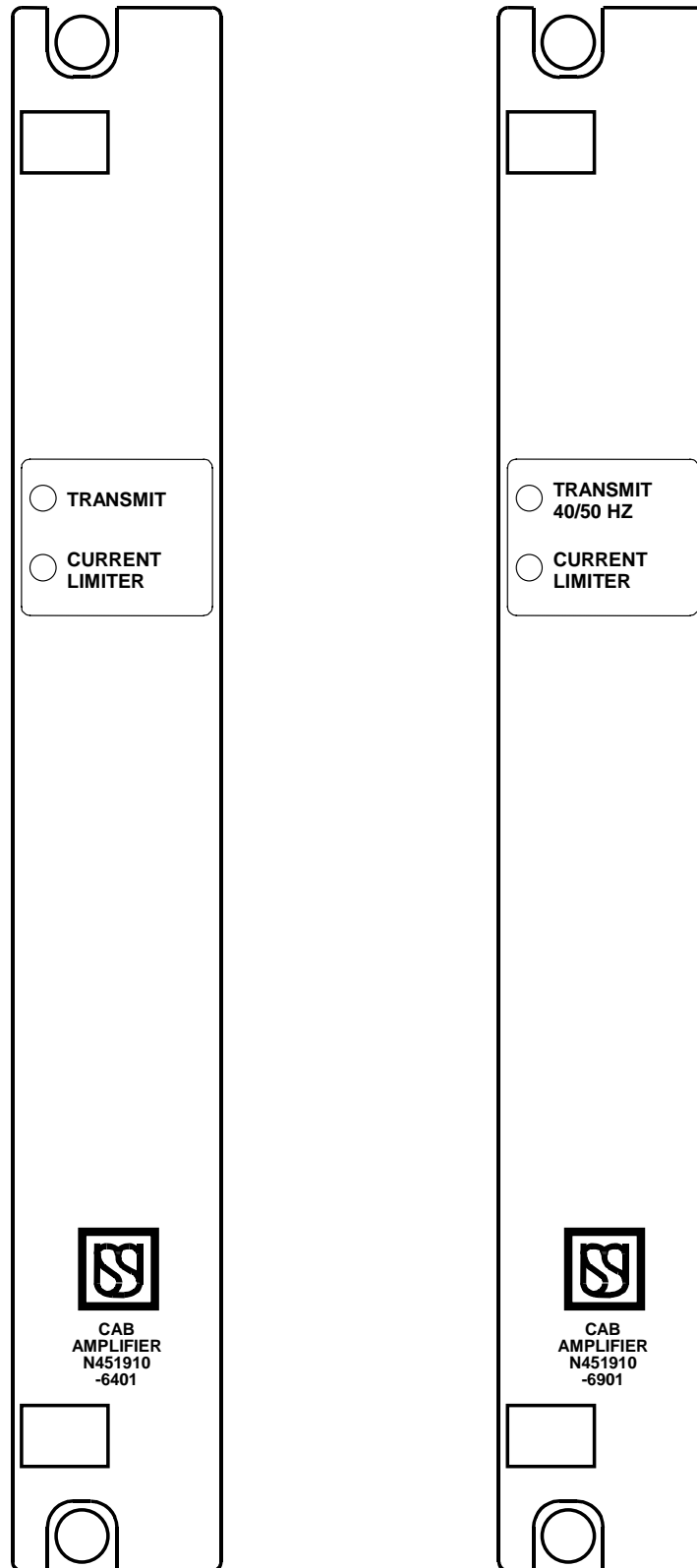

Figure 2-22. 60/100 and 40/50 Hz Cab Amplifier PCBs - Front Panel Layouts

2.5.2.11 Non-Vital I/O Printed Circuit Boards (Figures 2-23A, B, and C, and Figure 2-24)

The non-vital I/O printed circuit boards enable the Microlok II system to generate and monitor the status of non-vital discrete inputs and outputs. Examples of non-vital I/O include controlled outputs to light remote indicator lamps, and the I/O associated with the switches and indicators on the local control panel (if installed). Two versions of this board are provided. Part number N17000601 provides the necessary I/O interfaces between the Microlok II CPU and a local control panel (either an on-unit LCP or a remote unit). This board incorporates two separate sets of parallel I/O lines on separate front and rear edge connectors. The front 48-pin connector provides 16 inputs and 24 outputs for the LCP interface (Figure 2-24). The rear 48-pin (cardfile backplane) connector provides 16 inputs and 8 outputs for external circuits. The N17000601 board is installed behind the local control panel and has no visible front panel. I/O board part number N17061501 (Figure 2-23A) is used for external I/O circuits only, and provides 32 inputs and 32 outputs through its rear 96-pin connector.

The N17061501 board employs polyswitches to protect the output circuitry. A polyswitch functions like a circuit breaker. When the over current trip point (about 0.75 amp) is exceeded, the device switches to high impedance. The polyswitch returns to low impedance when the overload or short circuit condition is removed. Two outputs on both board types are protected by 5.0A fuse. These output circuits are reserved for control of a relatively high current device. Inputs on both boards are activated from a positive voltage relative to battery ground over a range of 6 to 30 Vdc. The non-vital I/O boards use latch ICs to buffer inputs and field effect transistors (FETs) to drive outputs.

Non-vital, optically isolated I/O PCBs are available as NV.OUT32 (N17062701), NV.IN32 (N17063701), and NV.IN32.OUT16 (N17002801). See Figures 2-23B and C for front panel diagrams. The NV.OUT32 PCB provides 32 isolated, outputs for control of external devices such as indicators and relays. The outputs are divided into two groups of 8 outputs and one group of 16 outputs, with each group having a separate bussed common (negative DC) reference output. Isolation allows switching power from sources isolated from the Microlok II power supply battery. Outputs are designed to operate at battery voltages between 9.5 and 35VDC. Outputs switch positive battery and are capable of supplying up to .5AMPS. Nominal voltage drop per output is load dependent and usually less than 2.5volts.

The NV.IN32 PCB provides 32 isolated external inputs. The 32 inputs are divided into two groups of 8 inputs and one group of 16 inputs, with each group having a separate bussed common (negative DC) reference input. External input voltages between 6 and 35VDC represent logical "1".

The NV.IN32.OUT16 PCB provides 16 isolated external inputs. These external inputs each have separate (+) and (-) connections and present a logical "1" when the applied voltage is 6 to 35VDC. This board also utilizes a Local Control Panel (LCP) N1700290X connected via a 96-pin connector to the front edge of the PCB. The LCP controls and monitors local non-vital circuits and devices through 16 inputs from the PCB and 16 outputs from the LCP to the PCB. Sixteen of the inputs are selectable by the front panel LCP pushbuttons. The 16 PCB outputs feed the LED indicators on the LCP.

2.5.2.12 Local Control Panel (Figure 2-24)

The optional Microlok II local control panel (part number N16901301) enables manual operation of interlocking switches, signals, and selected inputs and outputs. The on-unit panel is intended for simple interlockings such as single end-of-siding or crossovers. This device attaches to the cardfile frame and plugs into the 48-pin front connector of non-vital I/O printed circuit board N17000601 (described in the preceding paragraph). The LCP front panel devices include LEDs, 2-position toggle switches, and a key lock for enabling/disabling the operation of the LCP. Six LEDs are arrayed to allow arrangement of different interlocking track/signal configurations (east or west end-of-siding or single and double crossover, for example). A reversible plastic insert on the LCP front panel provides a legend for the panel switches and LEDs. This insert can be modified to mask selected LEDs as necessary based on the specific configuration of the associated interlocking.

2.5.3 Power Supply Board and System Power Configuration (Figure 2-25)

The N16600301 power supply board provides two regulated output voltages that are needed for the operation of the cardfile circuitry. The power supply board performs the following functions:

- Converts the external supply voltage (9.8 to 16.2 Vdc) to regulated $\pm 12\text{V}$ and $+5$ for outputs to the system cardfile internal circuits.
- Provides an isolated source voltage for external contact sensing.

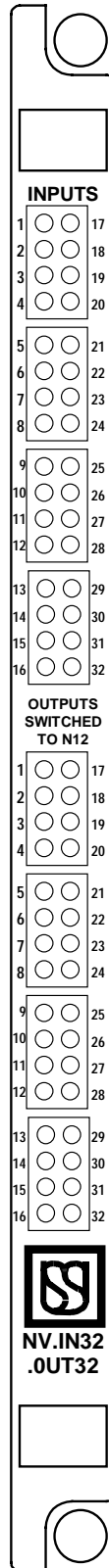

Figure 2-23A. Non-vital I/O PCB Front Panel Layout

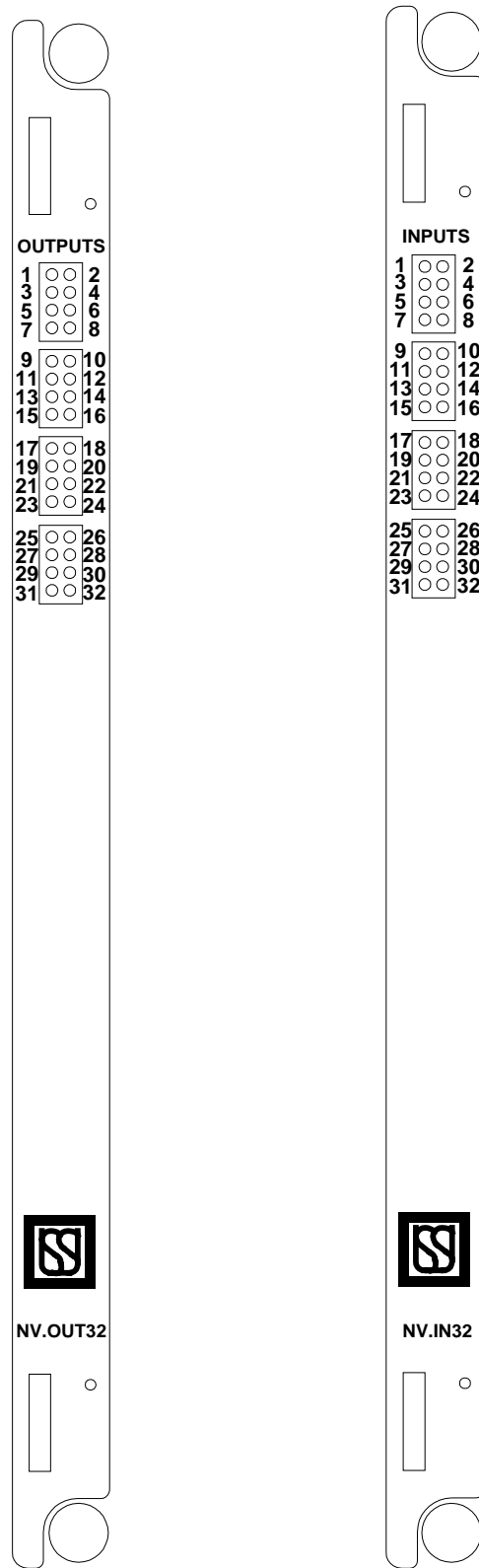

Figure 2-23B. Non-vital, isolated I/O PCBs Front Panel Layout

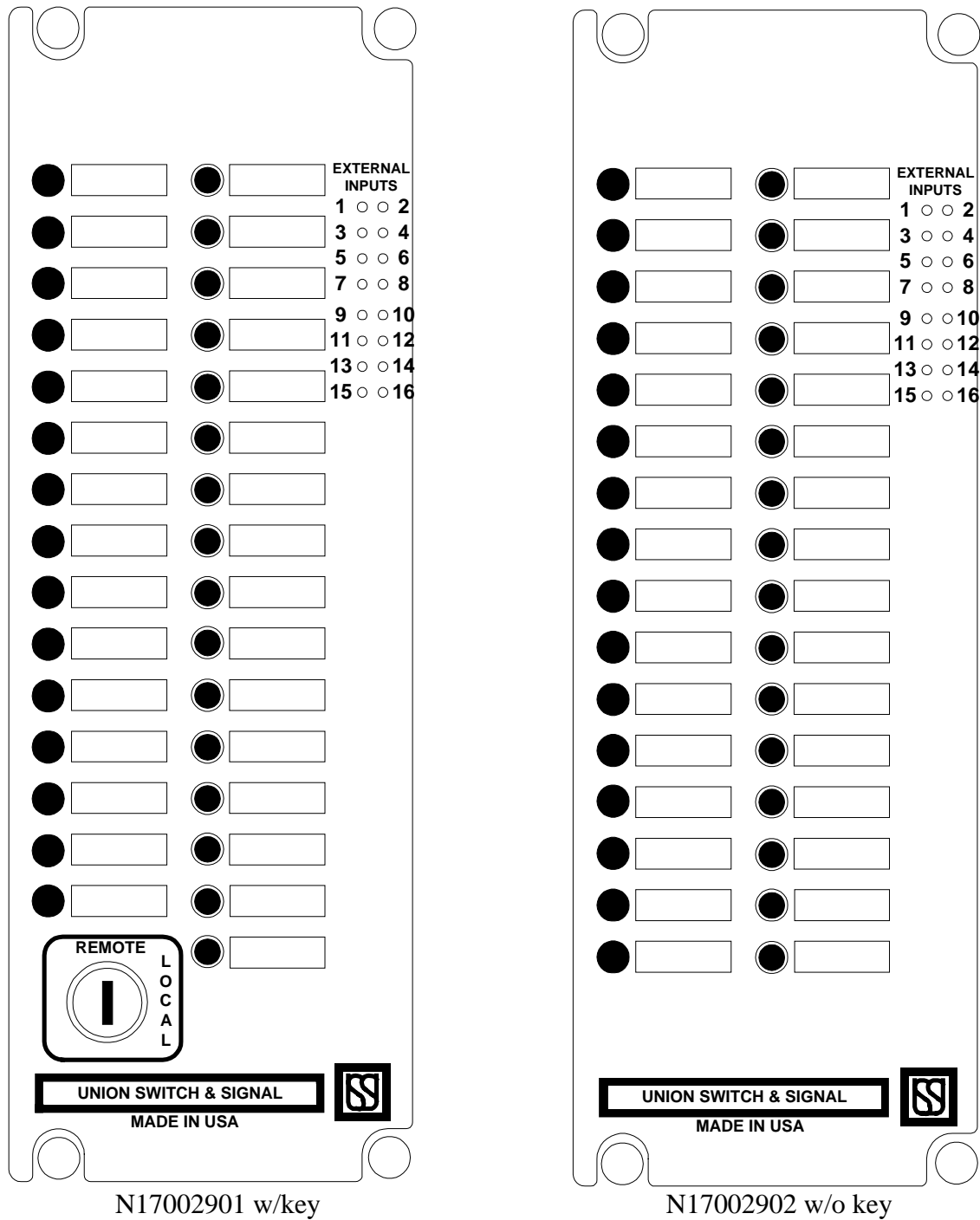

Figure 2-23C. LCP Panels for Non-vital isolated IN32.OUT16 PCB

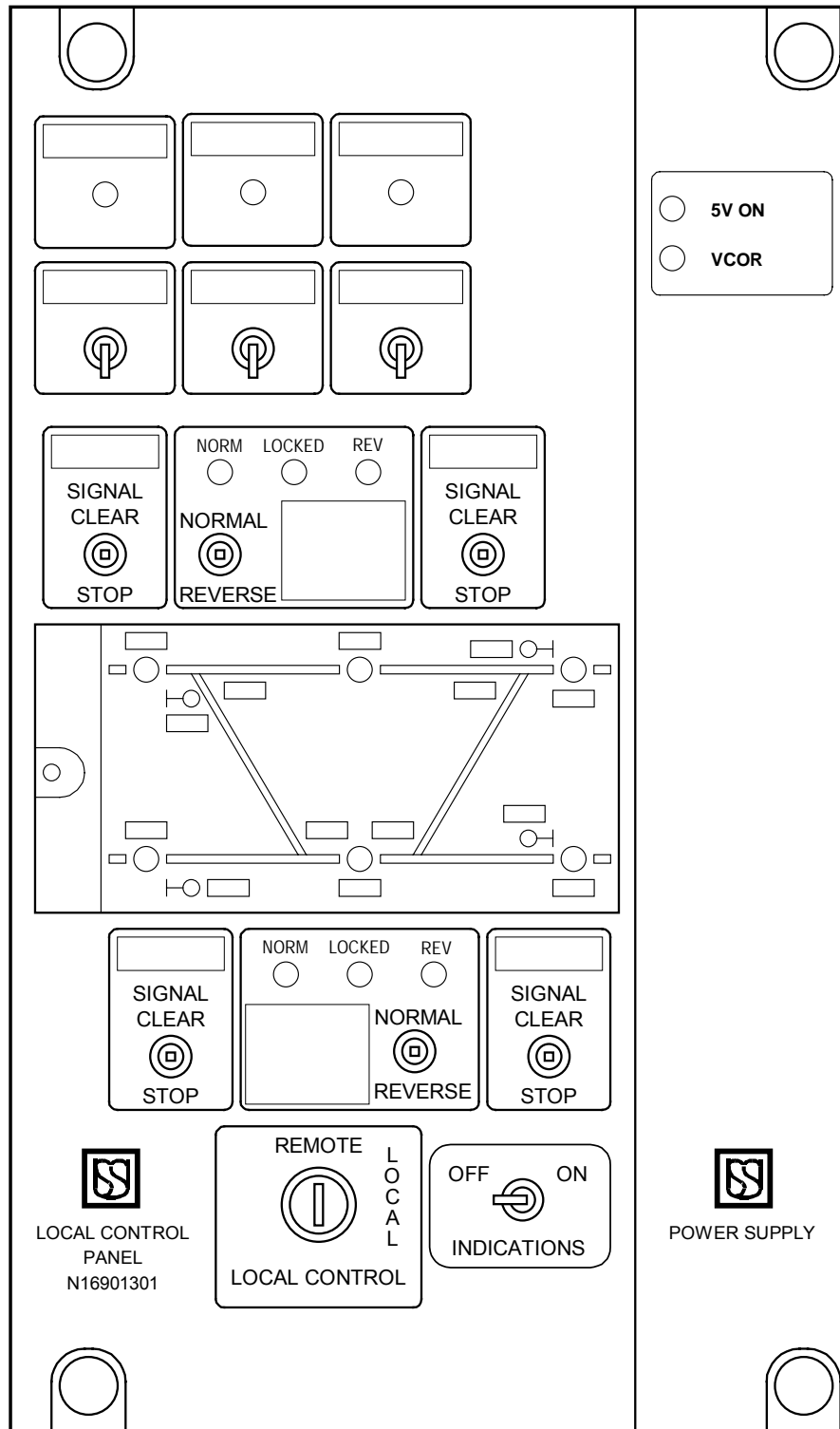

Figure 2-24. Local Control Panel Layout (with Rear-Mounted Power Supply PCB)

- Supplies energy to the VCOR relay coil under the control of the CPU printed circuit board.

The power supply board serves a vital role in the fail-safe design of the Microlok II system. The Microlok II CPU board outputs a 250 Hz check signal to the power supply board as long as the diagnostic checks performed continuously by the CPU detect no internal or external system faults. Failure of a diagnostic check results in the removal of the check signal from the power supply board. The power supply board responds by removing the hold voltage from the VCOR relay coil (400 Ω). This, in turn, results in removal of power to all vital system outputs.

The regulated $\pm 12\text{V}$ and $+5\text{V}$ power is distributed to all system cardfile printed circuit boards through the cardfile backplane bus. Both voltages are used to power board components and circuits. The $+12\text{V}$ output of the power supply board is not used as a source for any vital or non-vital outputs. External battery power is used for this purpose.

The optional Microlok II power-off relay provides a means of reporting a commercial power failure (serving the battery charger) to the Microlok II system. The output of this relay can be tied to a non-vital or vital input.

Refer to section 3.1 to ensure the combination of boards you have selected does not overload the system power supply.

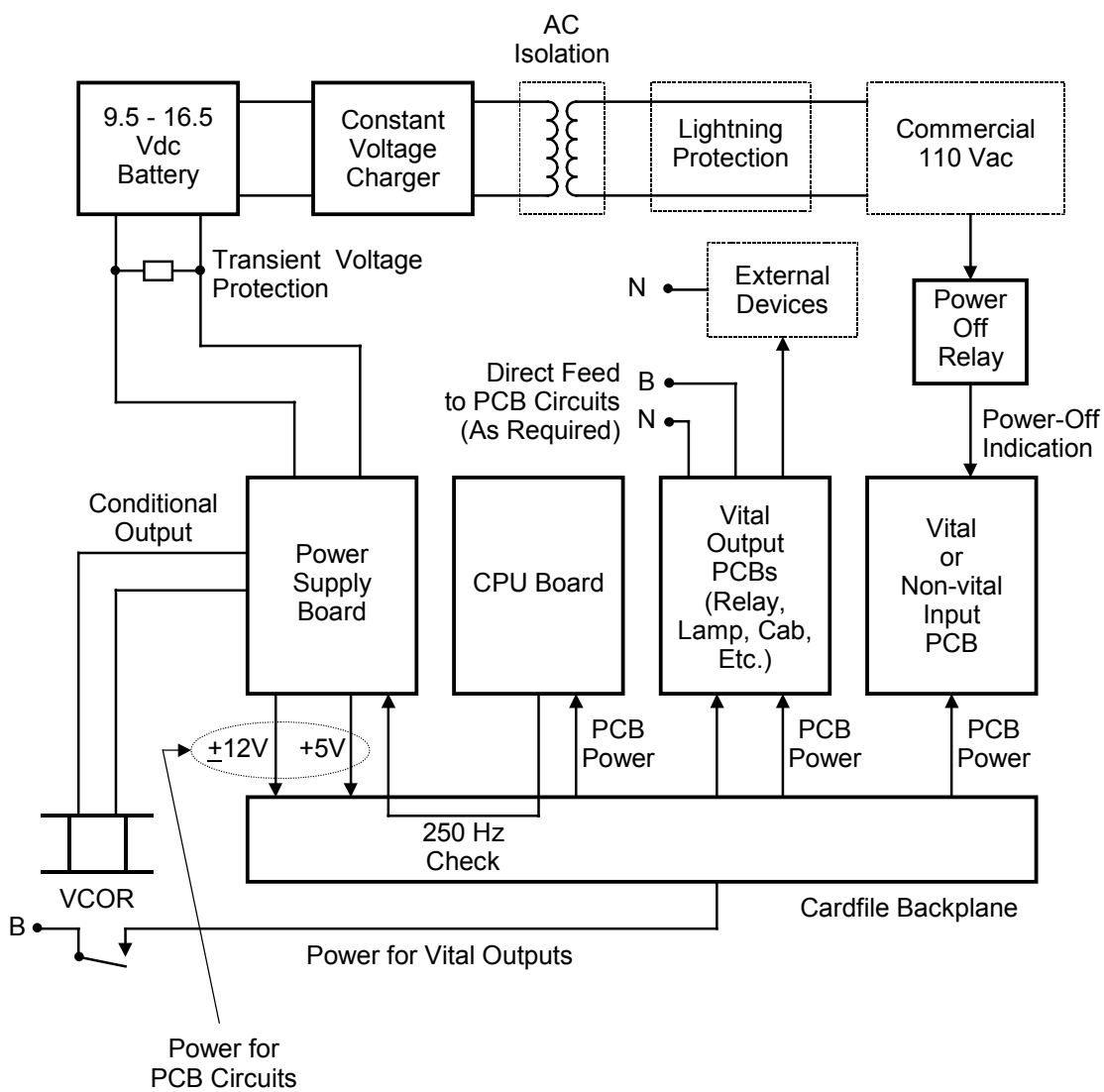

Figure 2-25. Basic Microlok II System Power Configuration

2.6 MICROLOK II AUXILIARY EQUIPMENT DESCRIPTIONS

In addition to the hardware contained in the Microlok II cardfile, some applications require the installation of specialized external interface equipment. This section provides an introduction to each of these modular units.

2.6.1 Coded Track Interface Panels (Figure 2-26)

The coded track interface panels carry all coded track communications between the Microlok II system cardfile and the rails. The circuitry associated with the interface panels optimizes track circuit efficiency and minimizes interference from other signals on the rails. Four versions of this panel are provided; these are the same units used with the MicroTrax track circuit systems.

Description	Application	US&S Part No.
Panel with 10 mH Inductor	General applications without cab signal	N451835-0101
Panel with 15 mH Inductors	Non-cab territories with 86 Hz crossing predictors.	N451835-0102
Panel with 20 mH Inductors	100 Hz cab territories. For use with cab signal interface panel N451835-0802.	N451835-0103
Panel with 40 mH Inductors	60 Hz cab territories. For use with cab signal interface panel N451835-0801.	N451835-0104

Panel components include an isolation transformer (784 turn primary and 112 turn secondary) and one or two inductors (reactors) wired as shown in Figure 2-26. Total inductance is established by coupling different combinations of 5, 10 and 20 mH inductors. These components are mounted on a stamped steel base that can be wall or shelf mounted. All external wiring is terminated on two, 2-way AAR terminal blocks.

The coded track interface panels can be augmented with a US&S termination capacitor printed circuit board (N451923-2501). This circuitry prevents the high power output of the cab signal transmitter (cardfile cab amplifier printed circuit board) from interfering with the coded track messages. The termination capacitor printed circuit board is mounted on the input-end AAR terminals of the cab signal compatible coded track interface panels.

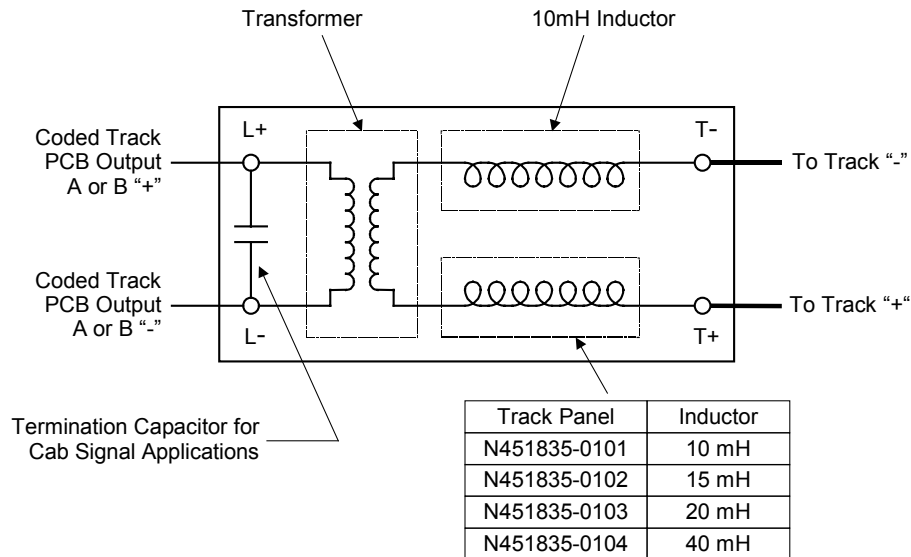

Figure 2-26. Coded Track Interface Panel Schematic

2.6.2 Quick Shunt Module

The optional quick shunt module is used in Microlok II coded track circuit systems to reduce the nominal 8-12 second shunt response time to approximately 100 msec. This module is intended for Microlok II coded track applications with heavy traffic and close headways. The quick shunt module is contained in a sheet metal enclosure with two 8-way screw lock connectors for wiring termination. Internal components include a receiver printed circuit board and transmitter printed circuit board. The transmitter printed circuit board provides a 2 KHz frequency source for the receiver. Two outputs on the transmitter feed two separate inputs on the receiver. The receiver rectifies the signal and filters it to a dc level, which is fed to the unit's external outputs.

2.6.3 Cab Signal Interface Panels (Figure 2-27)

The cab signal interface panels couple the cab signal, produced in the Microlok II system cardfile, to the rails. These panels are also used in the MicroTrax coded track circuit/cab signal controller. Three versions are provided:

Panel Part Number	Application
N451835-0801	Cab signal territories with 60 Hz carriers. For use with coded track interface panel N451835-0104.
N451835-0802	Cab signal territories with 100 Hz carriers. For use with coded track interface panel N451835-0103.
N451835-1101	Cab signal territories with 40 Hz carriers. For use with coded track interface panel N451835-0104.

The cab signal interface panel consists of a sheet metal mounting base designed for shelf, wall, or rack installation. Major components include a power transformer, an inductor (reactor), and a standoff-mounted printed circuit board. Track wiring is terminated on four AAR terminals, while

wiring to the Microlok II system cardfile is terminated on a 22-way terminal strip mounted on the circuit board.

Panel operating components/circuitry include the power transformer, series-tuned L/C filter with Q-spoiling resistor, and two relays (east and west of the track connection). The transformer primary is driven by a FET bridge circuit output of the cab amplifier printed circuit board in the system cardfile. Four taps on the transformer secondary select the required rail current level. Two jumpers are used (one per direction) to individually configure the taps for each output circuit.

The series-tuned L/C circuit consists of parallel-connected capacitors on the panel printed circuit board and a panel-mounted inductor (reactor). Jumpers on the printed circuit board are used to add or subtract capacitance to tune the L/C filter to the cab signal transmitter frequency. Refer to service manual SM-6800B for cab signal rail current and frequency fine-adjust procedures.

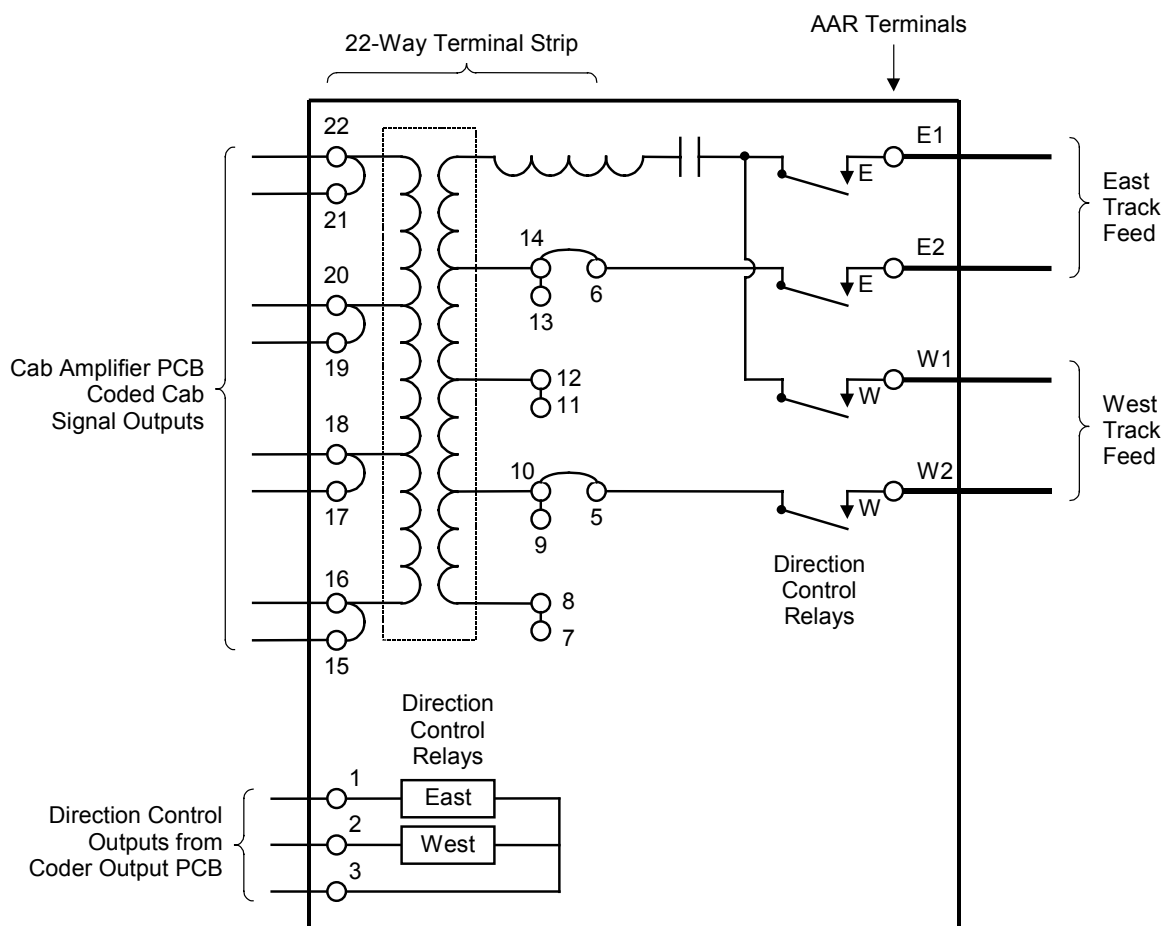

Figure 2-27. Cab Signal Interface Panel Circuits

2.6.4 Isolation Module

The Microlok II isolation module provides the equivalent of double-break circuit protection when the system is controlling vital relays or interfacing line circuits in a separate equipment house or case. This device can also be used to create a vital bi-polar output from two single break standard outputs. The module consists of a 2-piece plastic case with an internal dual-circuit printed circuit board and external screw lock wiring terminals. The case is mounted in a standard equipment rack using a DIN rail.

Three versions of the isolation module are provided:

- N17001101 12V output
- N17001102 50V output
- N17001103 24V output

Each module type is designed to operate from a nominal 12V battery source. The 12V version provides an output slightly greater than the battery source voltage. Current is limited to 0.4A with voltage foldback generally occurring at the same point. Output of the 50V version is also proportional to the battery source voltage with foldback occurring at about 0.13A. Outputs are short-circuit protected and are designed to withstand a single short to B12 or N12 without damage. The outputs can also withstand 2000V RMS to battery and earth ground.

2.6.5 VCOR Relay

The vital cut-off relay (VCOR) is used by the Microlok II system to control power to all vital outputs. This relay is energized by the conditional output from the power supply printed circuit board in the system cardfile. The Microlok II CPU board controls this fail-safe function. A US&S PN-150B vital biased relay (N322500-701) is used for the VCOR. This relay incorporates a 400 ohm coil, and 6FB contacts consisting of low voltage silver-to-silver fronts and silver-to-silver backs. Refer to section 3.10 for additional specifications on this relay.

2.6.6 Serial Communications Adapter Panel

The serial communications adapter panel is used in Microlok II applications that require a vital serial data link between systems in different equipment houses or cases. This panel converts the EIA-level signals at both ends of the link to a 20mA current loop level. This protects the serial channels from voltage transients. A single, standoff-mounted printed circuit board on the panel contains the EIA/current loop conversion circuitry. User devices include a power on/off switch, a fuse assembly, power status lamps, and communications status lamps for the current loop half of the interface. Refer to section 3.10 for additional product specifications.

3. SYSTEM SPECIFICATIONS

3.1 SYSTEM OPERATING POWER

Power Input to System Cardfile				
Voltage Range	Nominal Voltage	Min. Sys. Start-Up	Maximum Ripple	Current Draw
9.5 to 16.5 Vdc	12 Vdc	11.5 Vdc	0.5 V P-P	Determined by installation (number of signal lamps, cab carrier frequency, etc.)

Cardfile Power Supply Printed Circuit Board Outputs*		
For System Cardfile PCB 5V Internal Circuits	For System Cardfile PCB 12V Internal Circuits	To VCOR Relay
+5V @ 3A	+12V @ 1A, -12V @ 1A	+12V into 400 ohm coil
*Not used to power vital or non-vital external devices or circuits		

The table below is a list of the worst-case current draws for Microlok II system boards:

Board	Condition	+5V	+12V	-12V
NVB.OUT12 N17061801	12 LEDs on	140ma.	n/a	n/a
IN16 N17061001	16 LEDs on	170ma.	n/a	276ma.
IN8.OUT8 N17061601	16 LEDs on	150ma.	4ma.	147ma.
OUT16 N17060501	16 LEDs on	155ma.	6ma.	n/a
TRACK I/O N451901-0701	Normal Xmit and Rec.	4ma.	25ma.	20ma.
CPU N17061301	No serial links on	840ma.	4ma.	12ma.
CPU N17061301	Serial links on	1000ma.	4ma.	12ma.
LAMP16 N17060101	Lamp Driver	360ma.	20ma.	15ma
NV.IN32.OUT32 (W/O LCP) N17001501	64 LEDs on	576ma.	n/a	n/a
NV.IN32.OUT32 (W/LCP) N17000601	Maximum situation	150ma.	n/a	7ma.
CSIB N17061401	Normal display	900ma.	17ma.	26ma.
NV.OUT32 N17062701	32 LEDs on	144ma.	n/a	n/a
NV.IN32.OUT16 N17002801	48 LEDs on	333ma.	n/a	n/a
NV.IN.32 N17063701	32 LEDs on	341ma.	n/a	n/a

System Power Supply N16600301 is rated at 3 amps @ 5V, 1 am @ +12V, and 1 amp @ -12V.

3.2 VITAL INPUT AND OUTPUT PRINTED CIRCUIT BOARDS

3.2.1 Power Characteristics

Vital Input Printed Circuit Boards				
US&S Part No.	Nom. Input Voltage	Min. Voltage to Ensure ON State	Voltage to Ensure OFF State	Max. Sustained Input Voltage
N17061001	12V	9.5V	7.0V or less	34V
N17061002	24V	16.0V	12.0V or less	62V

Standard Vital Output Printed Circuit Boards				
US&S Part No.	Voltage V_{BATT} Range	Load Resistance Range	Max. OFF Voltage	Min. ON Voltage
N17060501	12V	50 Ω - ∞	0.75V	$V_{BATT} - 1V$
N17060502	24V	100 Ω - ∞	1.5V	$V_{BATT} - 1V$

Vital Lamp Driver Printed Circuit Board			
Signal Lamp Voltage Range	Max. Battery Voltage*	Signal Lamp Watt. Range	Max. Activated Load
10V - 12V	18V	18W - 36W	300W
*Used for long signal lamp leads.			

Mixed Vital I/O Printed Circuit Boards				
Output Specifications				
US&S Part No.	Voltage V_{BATT} Range	Load Resistance Range	Max. OFF Voltage	Min. ON Voltage
N17061601	12V	50 Ω - ∞	0.75V	$V_{BATT} - 1V$
N17061602	24V	100 Ω - ∞	1.5V	$V_{BATT} - 1V$
Input Specifications				
US&S Part No.	Nom. Input Voltage	Min. Voltage to Ensure ON State	Voltage to Ensure OFF State	Max. Sustained Input Voltage
N17061601	12V	9.5V	7.0V or less	34V
N17061602	24V	16.0V	12.0V or less	62V

3.2.2 Vital Data I/O Characteristics

Vital I/O Printed Circuit Boards			
Vital Input PCBs	Standard Vital Output PCBs	Vital Lamp Driver PCB	Mixed Vital I/O PCB
Both versions: Up to 16 isolated inputs	Both versions: Up to 16 single polarity, non-isolated outputs	Up to 12 25W signal lamps Up to 16 18W signal lamps Up to 8 36W signal lamps	Both versions: Up to 8 isolated inputs Up to 8 single polarity, non-isolated outputs

3.3 NON-VITAL I/O PRINTED CIRCUIT BOARDS POWER AND DATA I/O

Non-Vital I/O Printed Circuit Boards				
US&S Part No.	Input and Output Voltage Range	Externally Available Inputs	Externally Available Outputs	Current Rating On Outputs
N17000601	6.0 to 30.0VDC	16	8	Outputs 25-30: 0.5A fuse Outputs 31, 32: 5.0A fuse*
N17061501	6.0 to 30.0VDC	32	32	Outputs 1-30: 0.25A (polyswitch-protected) Outputs 31, 32: 5.0A fuse*
N17062701	9.5 to 35VDC	0	32	Outputs 1-32: 0.5AMPS
N17002801	6.0 to 35VDC	16**	0	Not applicable
N17063701	6.0 to 35VDC	32	0	Not applicable
N17061801	9.8 to 16.2VDC	0	12 bi-polar outputs	Nominal 250Ω load (PolySwitch Protected)
*Suitable for lighting lamp up to 25W.				
**Other 16 inputs and outputs are used by LCP panel.				

3.4 OS TRACK CIRCUIT COMMUNICATIONS

Transmitter/Receiver Frequency	Receiver Output Voltage	Track Circuit Length	Track Lead Resistance
400 Hz	12V to 20V dc 15V dc (nom.)	1000 ft. @ 5Ω/1000 ft. Ballast	0.5Ω (max.)

3.5 CODED TRACK CIRCUIT COMMUNICATIONS

3.5.1 Coded Track Circuit PCB Applications and Operating Power

US&S Part No.	Track Circuit Application	Track Circuit Operating Voltage
N451910-0701	General Non-cab and 100 Hz cab signal-compatible	9.5 to 16.5V dc
N451910-7601	40 Hz cab signal-compatible	9.5 to 16.5V dc
N451910-7602	50 Hz cab signal-compatible	9.5 to 16.5V dc
N451910-7603	60 Hz cab signal-compatible	9.5 to 16.5V dc

3.5.2 Coded Track Interface Panel Applications

US&S Part No.	Inductor	Application
N451835-0101	10 mH	General applications without cab signal
N451835-0102	15 mH	Non-cab territories with 86 Hz crossing predictors.
N451835-0103	20 mH	Cab signal territories with 100 Hz carriers. Use with cab signal interface panel N451835-0802.
N451835-0104	40 mH	Cab signal territories with 60 Hz carriers. Use with cab signal interface panel N451835-0801.

3.5.3 Track Circuit Length

Nominal Track Circuit Length	
Up to 23,000 ft.	@ 3 ohms per 1000 ft. ballast

Track Circuit Length by Rail Type, Rail Weight and Ballast			
Welded Rail*			
Rail Weight	@3 ohms	@4 ohms	@5 ohms
100#	21,000 ft.	25,000 ft.	29,000 ft.
118#	22,000 ft.	26,000 ft.	30,000 ft.
136#	22,000 ft.	27,000 ft.	31,000 ft.
145#	23,000 ft.	27,000 ft.	32,000 ft.
Bonded Rail*			
100#	18,000 ft.	22,000 ft.	25,000 ft.
118#	19,000 ft.	23,000 ft.	26,000 ft.
136#	19,000 ft.	23,000 ft.	27,000 ft.
145#	20,000 ft.	25,000 ft.	27,000 ft.

* Assumes 110 ft. or shorter #6 AWG (0.78 ohm) track leads at both ends. For longer leads, reduce max. distance by 1,000 ft. for each additional 100 ft. of leads.

3.5.4 Track Codes

Code/Message Format				
User-Available Codes	Format	Pulse Duration	Pulse Amplitude	Complete Transmit/Rec. Cycle
22	Bi-Polar	167 or 333 mS	2V P-P	6 seconds
Shunt Detection				
Std. Shunt Detect Response	Std. Shunt Clear Response (Application Logic Dependent)		Quick Shunt Detect Option	
6 to 12 seconds	12 to 18 sec.		100 msec (approximate)	

3.6 CAB SIGNAL GENERATION

3.6.1 Cab Signal Interface Panel Applications

US&S Part No.	Application
N451835-0801	Cab signal territories with 60 Hz carriers. (Use with Coded Track Interface Panel N451835-0104.)
N451835-0802	Cab signal territories with 100 Hz carriers. (Use with Coded Track Interface Panel N451835-0103.)
N451835-1101	Cab signal territories with 40 Hz carriers. (Use with Coded Track Interface Panel N451835-0104.)

3.6.2 Code Rates and Carrier Frequencies

Coder Output PCB Code Rates	Aux. Coder Output PCB Code Rates	Cab Amplifier Module Carriers	Aux. Cab Amplifier Module Carriers
75, 120, 180 CPM	50 CPM (2 separate outputs)	60 Hz or 100 Hz (Jumper-selected)	40 Hz or 50 Hz (Jumper-selected)

3.6.3 Battery Current Draw and Rail Current

Battery: No Outputs	Battery: 60 Hz Carrier 50% On Time	Battery: 100 Hz Carrier 50% On Time	Rail Current*: Entering End, 60 Hz Carrier:	Rail Current*: Entering End, 100 Hz Carrier:
1.5A	10.0A (max.)	15.0A (max.)	1.0A @10K ft. @ 4 ohms/1K ft. ballast	2.0A @8K ft. @ 4 ohms/1K ft. ballast
			*Based on 13V battery.	

3.7 CPU PRINTED CIRCUIT BOARD

3.7.1 Microprocessor

Type	Clock Speed	Internal Bit Operations	External Bus Operations
Motorola MC68332	21 MHz	32 bits wide	16 or 8 bits wide

3.7.2 Executive and Application EPROMs

Capacity and Type	Total Code Space	Clock Speed	Programming Voltages
Four Intel/Micron TE28F800CV-B90 Flash Type	Up to 8 megabytes (4M x 16)	21 MHz 1 wait state	+5V and +12V

3.7.3 RAM (Vital Data Processing and Event/Error Logs)

Vital Data: Type	Vital Data: Capacity:	Vital Data: Batt. Back-Up	Event/Error Data: Type	Event/Error Data: Capacity	Event/Error Data Batt. Back-Up
Fast Static RAM	2 banks of 64K x 16 (128K bytes)	None	Low Power Static Ram	4 banks of 512K x 16 (256K bytes)	>4 hrs. @25°C

3.7.4 Serial Communications Ports

3.7.4.1 COM1 Port

Type: EIA RS-485	TxD and RxD RTS and DCD TxClk and RxClk CTS	System ground referenced.	External terminations required
------------------	--	---------------------------	--------------------------------

3.7.4.2 COM2 Port

Type: EIA RS-485	TxD and RxD RTS and DCD	System ground referenced.	External terminations required
------------------	----------------------------	---------------------------	--------------------------------

3.7.4.3 COM3 Port

Types: EIA RS-232 or RS-423	TxD and RxD RTS and DCD TxClk and RxClk CTS	External signal reference pin (remote ground sensing).	External terminations required for RS-423
-----------------------------	--	--	---

3.7.4.4 COM4 Port

Type: EIA RS-232	TxD and RxD RTS and DCD	System ground referenced	Transmitter can be jumper-disabled
------------------	----------------------------	--------------------------	------------------------------------

3.7.4.5 COM5 Port (CPU Front Panel to PC)

Type: EIA RS-232	TxD and RxD	System ground referenced	Wired as DTE	Connector type: DB9 female
------------------	-------------	--------------------------	--------------	----------------------------

3.8 CODE SYSTEM INTERFACE PRINTED CIRCUIT BOARD

3.8.1 Available Code System Applications

ATC/PTS	Allen Bradley PF1	US&S GENISYS Dual Slave
US&S GENISYS	ARES	US&S GENISYS Dual Ind. Slave
Harmon MCS-1	GRS Datatrain II	
WB&S S2	GRS Datatrain VIII	

3.8.2 Microprocessor and Associated Memory

Microprocessor Type	Microprocessor Operation	Executive/Application EPROMs Quantity	Executive/Application EPROMs Capacity	RAM
Motorola MC68010	16-bit, 10 MHz Clock	2 Executive 1 or 2 Application	64K bytes per chip	Qty: 2 Capacity: 64KB x 8 bit bytes

3.8.3 Serial Communications Ports

Slave Serial I/O Port			
EIA RS-423 (RS-232/RS-422 compatible)	Synchronous or asynchronous operation	Baud rates: 150 to 19,200 BPS	Modes: Half or full duplex

Master Serial I/O Port			
EIA RS-423 (RS-232 compatible)	Asynchronous operation	Baud rates: 150 to 19,200 BPS	Modes: Half or full duplex

Front Panel PC Port				
EIA RS-232	Asynchronous operation	Baud rates: 150 to 19,200 BPS	Modes: Half or full duplex	Port Type: DB9

3.9 SYSTEM CARDFILE HARDWARE CONFIGURATION

Cardfile Mounting	PCB Mounting	Total PCB Slots	Slot Bus Addressing	Upper PCB Interface Connectors	Remote Power Supply Connector
Std. 19" rack, Shelf or wall	Eurocard	19	Via jumpers in connector housings	96-pin male	8-way screw lock discrete wire conn.

3.10 MISCELLANEOUS PERIPHERAL EQUIPMENT

3.10.1 VCOR Relay

Type	Contacts	Coil Resist. (Ohms)	Pickup Amps	Pickup DC Volts	System Voltage
US&S PN-150B N322500-701	6FB	400	0.0132	5.3	10

3.10.2 Power-Off Relay

Pickup Voltage	Contact Type	Contact Rating	Unit Mounting
110 to 120V ac	SPDT (1 Form C)	10 A	Std. rack via DIN rail

3.10.3 Isolation Module

US&S Part No.	Input Voltage Source	Output Voltage Rating	Output Current Rating	Breakdown	Unit Mounting
N17001101	12V (nom.)	12V*	0.4A	2000V rms to battery and ground	Std. rack via DIN rail
N17001102	12V (nom.)	50V	0.13A	2000V rms to battery and ground	Std. rack via DIN rail
N17001103	12V (nom.)	24V	--	2000V rms to battery and ground	Std. rack via DIN rail

3.10.4 Non-Vital Serial Link Isolator Unit

US&S Part No.	Operating Power Input	Serial Link Interfaces
All applications except ATCS MCP and ARES. Part no. N16901101	9.5 to 16.5V dc +12V dc (nom.)	25-Pin "D"

3.10.5 Serial Communications Adapter Panel

Comm. Power Input	EIA Level Signal Input	Converted Signal	Current Loop Cable
9.5 to 16.5V dc @200 ma, +12V dc (nom.)	RS-232/RS-423 compatible	20 ma current loop	5,000 ft. (max.) (10,000 ft. total cable path), 30/ Ω mile total resistance

3.11 ENVIRONMENTAL

System Cardfile Vibration	Operating Temperature Range (All Units)	Humidity Limit
1.0g rms, 0.2" displacement, 5-1000 Hz	-40°C to +70°C	95% non-condensing

