

# TECHNICAL MANUAL

## ARPT\*\*14\*\*, ARUF\*\*14\*\*, ASPT\*\*14\*\*, ASUF\*\*14\*\*

### Air Handlers

- Refer to Service Manual RS6200006 for installation, operation & troubleshooting information.
- All safety information must be followed as provided in the Service Manual.
- Refer to the appropriate Parts Catalog for part number information.
- Models listed on page 3.

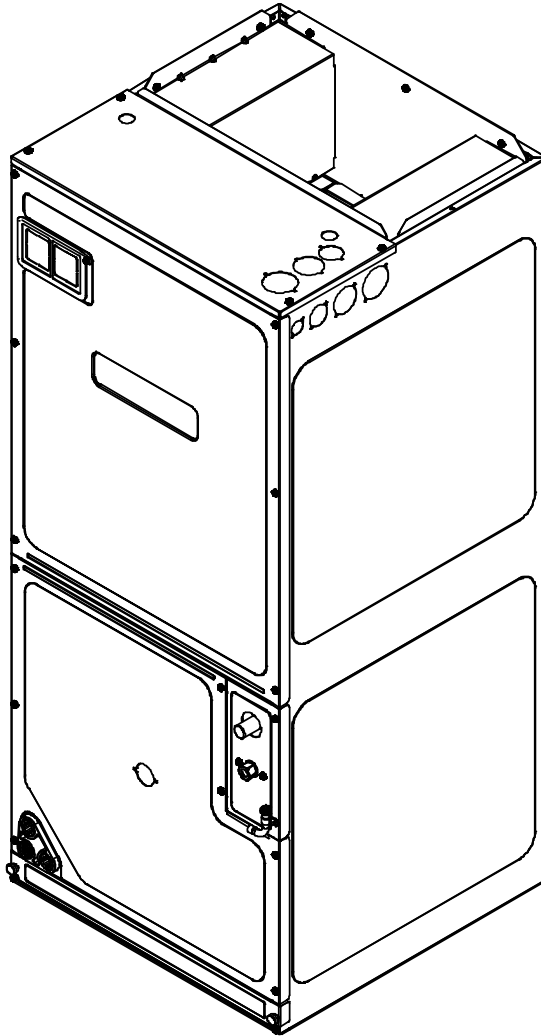

This manual is to be used by qualified, professionally trained HVAC technicians only. Goodman does not assume any responsibility for property damage or personal injury due to improper service procedures or services performed by an unqualified person.

RT6121003r9  
June 2014

# PRODUCT IDENTIFICATION

The model number is used for positive identification of component parts used in manufacturing. Please use this number when requesting service or parts information.

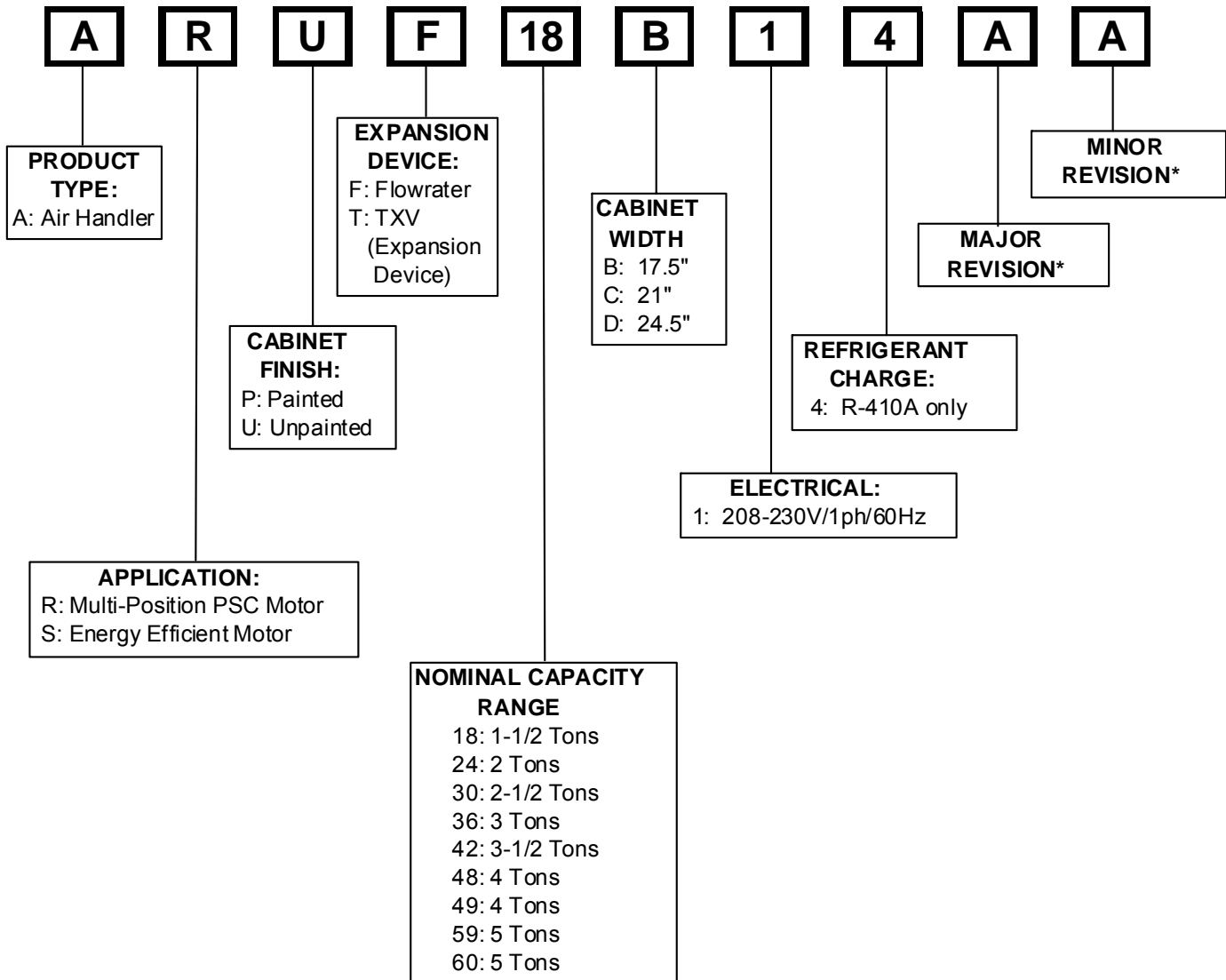

All Airhandlers use DIRECT DRIVE MOTORS. Power supply is AC 208-230v, 60 hz, 1 phase.

**WARNING**

**HIGH VOLTAGE!**  
Disconnect ALL power before servicing or installing this unit. Multiple power sources may be present. Failure to do so may cause property damage, personal injury or death.

**WARNING**

Goodman will not be responsible for any injury or property damage arising from improper service or service procedures. If you install or perform service on this unit, you assume responsibility for any personal injury or property damage which may result. Many jurisdictions require a license to install or service heating and air conditioning equipment.

**WARNING**

Installation and repair of this unit should be performed ONLY by individuals meeting the requirements of an "entry level technician", at a minimum, as specified by the Air-Conditioning, Heating, and Refrigeration Institute (AHRI). Attempting to install or repair this unit without such background may result in product damage, personal injury or death.

# PRODUCT IDENTIFICATION

The model number is used for positive identification of component parts used in manufacturing. Please use this number when requesting service or parts information.

ARPT18B14**	ASUF29B14**	ASPT42D14**
ARPT24B14**	ASUF39C14**	ASPT48D14**
ARPT30B14**	ASUF49C14**	ASPT60D14**
ARPT36C14**	ASUF59D14**	
ARPT36D14**		ARUF18B14**
ARPT42D14**	ASPT24B14**	ARUF24B14**
ARPT48D14**	ASPT30C14**	ARUF30B14**
ARPT60D14**	ASPT36C14**	ARUF30C14**
	ASPT42C14**	ARUF36C14**
	ASPT48C14**	ARUF42C14**
		ARUF48D14**
		ARUF60D14**

## WARNING

The United States Environmental Protection Agency (“EPA”) has issued various regulations regarding the introduction and disposal of refrigerants introduced into this unit. Failure to follow these regulations may harm the environment and can lead to the imposition of substantial fines. These regulations may vary by jurisdiction. Should questions arise, contact your local EPA office.

## WARNING

Do not connect or use any device that is not design certified by Goodman for use with this unit. Serious property damage, personal injury, reduced unit performance and/or hazardous conditions may result from the use of such non-approved devices.

## WARNING

To prevent the risk of property damage, personal injury, or death, do not store combustible materials or use gasoline or other flammable liquids or vapors in the vicinity of this appliance.

## WARNING

When installing or servicing this equipment, safety clothing, including hand and eye protection, is strongly advised. If installing this equipment in an area that has special safety requirements (hard hats etc.), observe these requirements. To protect the unit when brazing close to the painted surfaces, the use of a quenching cloth is strongly advised to prevent scorching or marring of the equipment finish.

## WARNING

The unit MUST have an uninterrupted, unbroken electrical ground to minimize the possibility of personal injury if an electrical fault should occur. The electrical ground circuit may consist of an appropriately sized electrical wire connecting the ground lug in the unit control box to the building electrical service panel. Other methods of grounding are permitted if performed in accordance with the “National Electric Code” (NEC)/“American National Standards Institute” (ANSI)/“National Fire Protection Association” (NFPA) 70 and local/state codes. In Canada, electrical grounding is to be in accordance with the Canadian Electric Code CSA C22.1. Failure to observe this warning can result in electrical shock that can cause personal injury or death.

# PRODUCT DESIGN



## WARNING

If this appliance is installed in an enclosed area such as a garage or utility room with any carbon monoxide (CO) producing appliance (i.e. automobile, furnace, water-heaters, etc.), ensure the area is properly ventilated.



## WARNING HIGH VOLTAGE

Disconnect ALL power before servicing or installing this unit. Multiple power sources may be present. Failure to do so may cause property damage, personal injury or death.



### AIR HANDLERS

See Air Handler Specification Sheet for Proper Combinations.

ALL AIR HANDLERS USE DIRECT DRIVE MOTORS. POWER SUPPLY IS 208-230 V, 60 HZ, 1 PHASE.

#### Installation

Before installing this appliance insure that it is properly sized and adequate power is available.

This appliance can be installed in the vertical or right horizontal position without modification. The horizontal left and downflow positions require product modification.

This product is designed for zero inches (0 inches) clearance; however, adequate access for service or replacement must be considered without removing permanent structure. This unit can be installed on a platform when deemed necessary.

In an attic installation a secondary drain pan must be provided by the installer and placed under the entire unit with a separate drain line properly sloped and terminated in an area visible to the owner. This secondary drain pan is required in the event that there is a leak or main drain blockage. Closed cell insulation should be applied to the drain lines in unconditioned spaces where sweating may occur.

Appliances installed in garages, warehouses or other areas where they may be subjected to mechanical damage must be suitably guarded against such damage by installing behind protective barriers, being elevated or located out of the normal path of vehicles. When installed on a base, the base must also be protected by similar means.

Heating and cooling equipment located in garages, which may generate a glow, spark or flame capable of igniting flammable vapors, must be installed with the ignition source at least 18"[46cm] above the floor level.

When more than one appliance is installed in a building it shall be permanently identified as to the area or space serviced by the equipment.

When this product is installed in the downflow installation in an unconditioned space, remove the horizontal drain pan and install the following insulation kit.

### MODEL LIST FOR DOWNFLOW KITS

DFK-B Downflow Kit	DFK-C Downflow Kit	DFK-D Downflow Kit
ARUF18B14**	ARUF30C14**	ARUF48D14**
ARUF24B14**	ARUF36C14**	ARUF60D14**
ARUF30B14**	ARUF42C14**	ARPT36D14**
ARPT18B14**	ARPT36C14**	ARPT42D14**
ARPT24B14**	ASUF39C14**	ARPT48D14**
ARPT30B14**	ASUF49C14**	ARPT60D14**
ASUF29B14**	ASPT30C14**	ASUF59D14**
ASPT24B14**	ASPT36C14**	ASPT42D14**
	ASPT42C14**	ASPT48D14**
	ASPT48C14**	ASPT60D14**

This kit is used to prevent sweating on the vertical drain pan.

**ARPT, ARUF, ASPT** and **ASUF** air handlers are multi-position, multi-speed with direct drive motors. **ARPT** and **ARUF** are available in 1 1/2 to 5 ton sizes with optional 3 kW to 25kW electric heat kits available for field installation. (See note below.)

**ASPT** air handlers are available in 2, 3, 4 and 5 ton sizes with optional 3 kW to 25kW electric heat kits available for field installation. (See following note.)

**NOTE:** Factory-sealed to achieve a 2% or less leakage rate at 1.0" water gauge external duct static pressure.

Complies with the Factory-sealed Air Handling Credit as listed in the 2001 Florida Building Code, Chapter 13, Section 610.2.A.2.1.

# HKS HEAT KITS

# ARPT\*\*14\*\*

Heat Kit Applications	ARPT							
	18B14-A*	24B14-A*	30B14-A*	36C14-A*	36D14-A*	42D14-A*	48D14-A*	60D14-A*
HKSX03XC*	X	X	X	X	X	X	X	X
HKSX05XC*	X	X	X	X	X	X	X	X
HKSX06XC*	X	X	X	X	X	X	X	X
HKSX08XC*	X	X	X	X	X	X	X	X
HKSX10XC*	X	X	X	X	X	X	X	X
HSKX15XF*				X	X	X	X	X
HSKX20XF*				X	X	X	X	X
HKSC05XC*	X	X	X	X	X	X	X	X
HKSC08XC*	X	X	X	X	X	X	X	X
HKSC10XC*	X	X	X	X	X	X	X	X
HKSC15XA*			X	X	X	X	X	X
HKSC15XB*			X	X	X	X	X	X
HKSC15XF*				X	X	X	X	X
HKSC19CA*				X				
HKSC19CB*				X				
HKSC20DA*					X	X	X	X
HKSC20DB*					X	X	X	X
HKSC20XF*				X	X	X	X	X
HKSC25DC*							X	X

\* Revision level that may or may not be designated

Refer to the minimum airflow requirements for each of the heat kits.

# HKS HEAT KITS

# ARUF\*\*14\*\*

Heat Kit Applications	ARUF								
	18B14-A*	24B14-B*	24B14-C*	30B14-A*	30C14-B*	36C14-B*	42C14-A*	48D14-A*	60D14-A*
HKSX03XC*	X	X	X	X	X	X	X	X	X
HKSX05XC*	X	X	X	X	X	X	X	X	X
HKSX06XC*	X	X	X	X	X	X	X	X	X
HKSX08XC*	X	X	X	X	X	X	X	X	X
HKSX10XC*	X	X	X	X	X	X	X	X	X
HKSX15XF*					X	X	X	X	X
HKSX20XF*					X	X	X	X	X
HKSC05XC*	X	X	X	X	X	X	X	X	X
HKSC08XC*	X	X	X	X	X	X	X	X	X
HKSC10XC*	X	X	X	X	X	X	X	X	X
HKSC15XA*				X	X	X	X	X	X
HKSC15XB*				X	X	X	X	X	X
HKSC15XF*					X	X	X	X	X
HKSC19CA*					X	X	X		
HKSC19CB*					X	X	X		
HKSC20DA*								X	X
HKSC20DB*								X	X
HKSC20XF*					X	X	X	X	X
HKSC25DC*							X	X	X

\* Revision level that may or may not be designated

Refer to the minimum airflow requirements for each of the heat kits.

*ARUF ARPT	HEATER (kW)								
	3	5	6	8	10	15	19	20	25
18	715	715	715	715	950				
24	715	715	715	715	950				
30B	715	715	715	715	875	875			
30C		1170	1170	1170	1170	1345	1345		
36		1170	1170	1170	1170	1345	1345		
42		1170	1170	1170	1170	1345	1345		
48		1590	1590	1590	1590	1715		1715	1715
60		1590	1590	1590	1590	1715		1715	1715

Minimum CFM required for Heater Kits

# HKS HEAT KITS

# ASPT\*\*14\*\*

Heat Kit Applications	ASPT					
	24B14-A*	36C14-A*	42C14-A*	48C14-A*	48D14-A*	60D14-A*
HK SX03XC*	X	X	X	X	X	X
HK SX05XC*	X	X	X	X	X	X
HK SX06XC*	X	X	X	X	X	X
HK SX08XC*	X	X	X	X	X	X
HK SX10XC*	X	X	X	X	X	X
HK SX15XF*		X	X	X	X	X
HK SX20XF*		X	X	X	X	X
HK SC05XC*	X	X	X	X	X	X
HK SC08XC*	X	X	X	X	X	X
HK SC10XC*	X	X	X	X	X	X
HK SC15XA*		X	X	X	X	X
HK SC15XB*		X	X	X	X	X
HK SC15XF*		X	X	X	X	X
HK SC19CA*		X	X	X		
HK SC19CB*		X	X	X		
HK SC20DA*					X	X
HK SC20DB*					X	X
HK SC20XF*		X	X	X	X	X
HK SC25DC*					X	X

\* Revision level that may or may not be designated.

Refer to the minimum airflow requirements for each of the heat kits.

	Heater (KW)								
	3	5	6	8	10	15	19	20	25
ASPT24B14*	715	715	715	715	875	NR	NR	NR	NR
ASPT30C14*	730	715	715	715	950	NR	NR	NR	NR
ASPT36C14*	NR	1170	1170	1170	1170	1345	1345	1345	NR
ASPT42C14*	NR	1170	1170	1170	1170	1345	1345	1345	NR
ASPT48C14*	NR	1170	1170	1170	1170	1345	1345	1345	NR
ASPT42D14*	NR	1590	1590	1590	1590	1715	NR	1715	NR
ASPT48D14*	NR	1590	1590	1590	1590	1715	NR	1715	1715
ASPT60D14*	NR	1590	1590	1590	1590	1715	NR	1715	1715

MINIMUM CFM REQUIRED FOR HEATER KITS

# HKS HEAT KITS

# ASUF\*\*14\*\*

Heat Kit Applications	ASUF			
	29B14-A*	39C14-A*	49C14-A*	59D14-A*
HKSX03XC*	X	X	X	X
HKSX05XC*	X	X	X	X
HKSX06XC*	X	X	X	X
HKSX08XC*	X	X	X	X
HKSX10XC*	X	X	X	X
HKSX15XF*		X	X	X
HKSX20XF*		X	X	X
HKSC05XC*	X	X	X	X
HKSC08XC*	X	X	X	X
HKSC10XC*	X	X	X	X
HKSC15XA*		X	X	X
HKSC15XB*		X	X	X
HKSC15XF*		X	X	X
HKSC19CA*		X	X	
HKSC19CB*		X	X	
HKSC20DA*				X
HKSC20DB*				X
HKSC20XF*		X	X	X
HKSC25DC*				X

\* Revision level that may or may not be designated.

Refer to the minimum airflow requirements for each of the heat kits.

ASUF	HEATER (kW)								
	3	5	6	8	10	15	19	20	25
29	715	715	715	715	875				
39		1170	1170	1170	1170	1345	1345		
49		1170	1170	1170	1170	1345	1345		
59		1590	1590	1590	1590	1715		1715	1715

Minimum CFM required for Heater Kits



# PRODUCT DIMENSIONS ARPT\*\*14\*\*/ARUF\*\*14\*\*/ASPT\*\*14\*\*/ASUF\*\*14\*\*

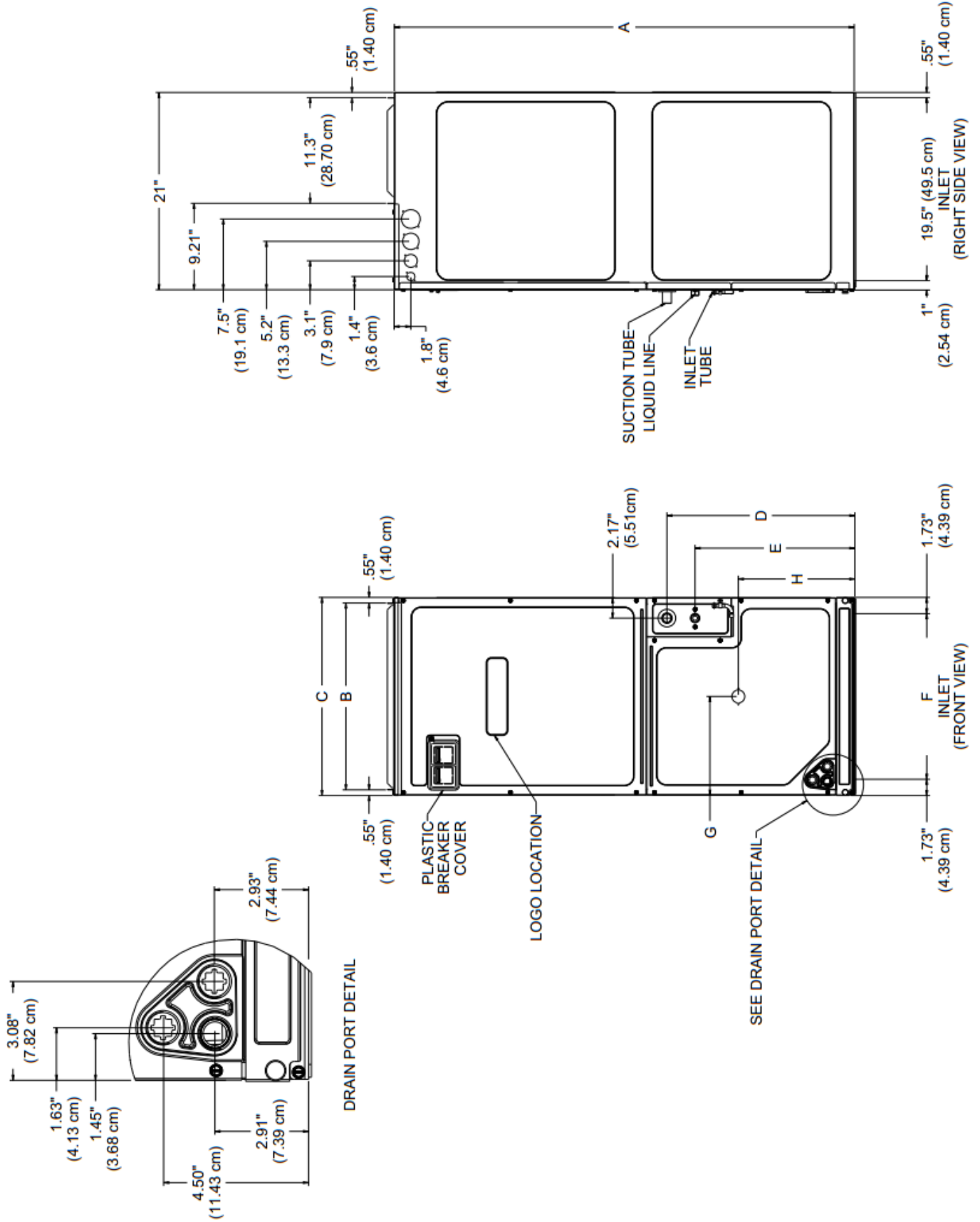

# PRODUCT DIMENSIONS

ARPT\*\*14\*\*/ARUF\*\*14\*\*

Model	A	B	C	D	E	F	G	H
ARPT18B14*	45	16 3/8	17 1/2	18	15	14 3/16	8 13/16	11 15/16
ARPT24B14*	45	16 3/8	17 1/2	18	15	14 3/16	8 13/16	11 15/16
ARPT30B14*	45	16 1/8	17 1/2	18	15	14 3/16	8 13/16	11 15/16
ARPT36C14*	49	19 15/16	21	20	17	17 11/16	10 1/2	12 3/8
ARPT36D14*	58	23 5/16	24 1/2	28 3/16	25 3/16	21 3/16	12 5/16	12 3/8
ARPT42D14*	58	23 5/16	24 1/2	28 3/16	25 3/16	21 3/16	12 5/16	12 3/8
ARPT48D14*	58	23 5/16	24 1/2	28 3/16	25 3/16	21 3/16	12 5/16	12 3/8
ARPT60D14*	58	23 5/16	24 1/2	28 3/16	25 3/16	21 3/16	12 5/16	12 3/8

Dimensions are in inches.

Model	A	B	C	D	E	F	G	H
ARUF18B14*	45	16 <sup>3</sup> / <sub>8</sub>	17 <sup>1</sup> / <sub>2</sub>	18	15	14 <sup>3</sup> / <sub>16</sub>	8 <sup>13</sup> / <sub>16</sub>	11 <sup>15</sup> / <sub>16</sub>
ARUF24B14*	45	16 <sup>3</sup> / <sub>8</sub>	17 <sup>1</sup> / <sub>2</sub>	18	15	14 <sup>3</sup> / <sub>16</sub>	8 <sup>13</sup> / <sub>16</sub>	11 <sup>15</sup> / <sub>16</sub>
ARUF30B14*	45	16 <sup>3</sup> / <sub>8</sub>	17 <sup>1</sup> / <sub>2</sub>	18	15	14 <sup>3</sup> / <sub>16</sub>	8 <sup>13</sup> / <sub>16</sub>	11 <sup>15</sup> / <sub>16</sub>
ARUF30C14*	49	19 <sup>15</sup> / <sub>16</sub>	21	20	17	17 <sup>11</sup> / <sub>16</sub>	10 <sup>1</sup> / <sub>2</sub>	12 <sup>3</sup> / <sub>8</sub>
ARUF36C14*	49	19 <sup>15</sup> / <sub>16</sub>	21	20	17	17 <sup>11</sup> / <sub>16</sub>	10 <sup>1</sup> / <sub>2</sub>	12 <sup>3</sup> / <sub>8</sub>
ARUF42C14*	49	19 <sup>15</sup> / <sub>16</sub>	21	20	17	17 <sup>11</sup> / <sub>16</sub>	10 <sup>1</sup> / <sub>2</sub>	12 <sup>3</sup> / <sub>8</sub>
ARUF48D14*	58	23 <sup>5</sup> / <sub>16</sub>	24 <sup>1</sup> / <sub>2</sub>	28 <sup>3</sup> / <sub>16</sub>	25 <sup>3</sup> / <sub>16</sub>	21 <sup>3</sup> / <sub>16</sub>	12 <sup>5</sup> / <sub>16</sub>	12 <sup>3</sup> / <sub>8</sub>
ARUF60D14*	58	23 <sup>5</sup> / <sub>16</sub>	24 <sup>1</sup> / <sub>2</sub>	28 <sup>3</sup> / <sub>16</sub>	25 <sup>3</sup> / <sub>16</sub>	21 <sup>3</sup> / <sub>16</sub>	12 <sup>5</sup> / <sub>16</sub>	12 <sup>3</sup> / <sub>8</sub>

Dimensions are in inches.

# PRODUCT DIMENSIONS

ASPT\*\*14\*\*/ASUF\*\*14\*\*

Model	A	B	C	D	E	F	G	H
ASPT24B14*	45	16 <sup>3</sup> / <sub>8</sub>	17½	18	15	14 <sup>3</sup> / <sub>16</sub>	8 <sup>13</sup> / <sub>16</sub>	11 <sup>15</sup> / <sub>16</sub>
ASPT30C14*	49	19 <sup>15</sup> / <sub>16</sub>	21	20	17	17 <sup>11</sup> / <sub>16</sub>	10½	12 <sup>3</sup> / <sub>8</sub>
ASPT36C14*	49	19 <sup>15</sup> / <sub>16</sub>	21	20	17	17 <sup>11</sup> / <sub>16</sub>	10½	12 <sup>3</sup> / <sub>8</sub>
ASPT42C14*	49	19 <sup>15</sup> / <sub>16</sub>	21	20	17	17 <sup>11</sup> / <sub>16</sub>	10½	12 <sup>3</sup> / <sub>8</sub>
ASPT48C14*	49	19 <sup>15</sup> / <sub>16</sub>	21	20	17	17 <sup>11</sup> / <sub>16</sub>	10½	12 <sup>3</sup> / <sub>8</sub>
ASPT42D14*	58	23 <sup>5</sup> / <sub>16</sub>	24½	28 <sup>3</sup> / <sub>16</sub>	25 <sup>3</sup> / <sub>16</sub>	21 <sup>3</sup> / <sub>16</sub>	12 <sup>5</sup> / <sub>16</sub>	12 <sup>3</sup> / <sub>8</sub>
ASPT48D14*	58	23 <sup>5</sup> / <sub>16</sub>	24½	28 <sup>3</sup> / <sub>16</sub>	25 <sup>3</sup> / <sub>16</sub>	21 <sup>3</sup> / <sub>16</sub>	12 <sup>5</sup> / <sub>16</sub>	12 <sup>3</sup> / <sub>8</sub>
ASPT60D14*	58	23 <sup>5</sup> / <sub>16</sub>	24½	28 <sup>3</sup> / <sub>16</sub>	25 <sup>3</sup> / <sub>16</sub>	21 <sup>3</sup> / <sub>16</sub>	12 <sup>5</sup> / <sub>16</sub>	12 <sup>3</sup> / <sub>8</sub>

*Dimensions are in inches.*

Model	A	B	C	D	E	F	G	H
ASUF29B14*	45	16 3/8	17 1/2	18	15	14 3/16	8 13/16	11 15/16
ASUF39C14*	49	19 15/16	21	20	17	17 11/16	10 1/2	12 3/8
ASUF49C14*	49	19 15/16	21	20	17	17 11/16	10 1/2	12 3/8
ASUF59D14*	58	23 5/16	24 1/2	28 3/16	25 3/16	21 3/6	12 5/16	12 3/8

*Dimensions are in inches.*

# PRODUCT SPECIFICATIONS

# ARPT\*\*14\*\*

	ARPT 18B14*	ARPT 24B14*	ARPT 30B14*	ARPT 36C14*	ARPT 36D14*	ARPT 42D14*	ARPT 48D14*	ARPT 60D14*
Nominal Ratings								
Cooling (Btu/h)	18,000	24,000	30,000	36,000	36,000	42,000	48,000	60,000
Airflow Rate CFM *								
High	1065	1065	1020	1445	1705	1810	1845	2080
Med	825	825	775	1300	1485	1555	1495	1865
Low	560	560	565	1175	1140	1350	1280	1505
Blower								
Diameter	9½"	9½"	9½"	10⅝"	10⅝"	10⅝"	11 <sup>15</sup> / <sub>16</sub> "	11 <sup>15</sup> / <sub>16</sub> "
Width	6"	6"	6"	8"	10⅝"	10⅝"	10⅝"	10⅝"
Coil Drain Connect FPT	¾"	¾"	¾"	¾"	¾"	¾"	¾"	¾"
Refrigerant Line Connection Size								
Liquid	⅜"	⅜"	⅜"	⅜"	⅜"	⅜"	⅜"	⅜"
Suction	¾"	¾"	¾"	⅞"	⅞"	⅞"	⅞"	⅞"
Electrical Data								
Voltage	208 / 230	208 / 230	208 / 230	208 / 230	208 / 230	208 / 230	208 / 230	208 / 230
Min Circuit Ampacity	3 / 3	3 / 3	3 / 3	4 / 4	4 / 4	5 / 5	5 / 5	6 / 6
Max. Overcurrent Device (amps)	15 / 15	15 / 15	15 / 15	15 / 15	15 / 15	15 / 15	15 / 15	15 / 15
Min. / Max VAC	197 / 253	197 / 253	197 / 253	197 / 253	197 / 253	197 / 253	197 / 253	197 / 253
Blower Motor FLA/ HP	1.9 / ⅓	1.9 / ⅓	1.9 / ⅓	3.1 / ⅓	3.0 / ½	3.5 / ½	3.5 / ½	4.6 / ¾
Ship Weight (lbs)	100	100	105	118	155	155	167	167

\*Airflow rate @.3 static

# PRODUCT SPECIFICATIONS

# ARUF\*\*14\*\*

	ARUF 18B14*	ARUF 24B14*	ARUF 30B14*	ARUF 30C14*	ARUF 36C14*	ARUF 42C14*	ARUF 48D14*	ARUF 60D14*
<b>Nominal Ratings</b>								
Cooling (Btu/h)	18,000	24,000	30,000	36,000	36,000	42,000	48,000	60,000
Airflow rate CFM*								
High	1045	1045	1020	1385	1385	1465	1810	2125
Med	835	835	775	1235	1235	1290	1555	1885
Low	565	565	565	980	980	1000	1350	1455
<b>Blower</b>								
Diameter	9½"	9½"	9½"	10⅝"	10⅝"	10⅝"	10⅝"	11 <sup>15</sup> / <sub>16</sub> "
Width	6"	6"	6"	8"	8"	8"	10⅝"	10⅝"
Coil Drain Connect FPT	¾"	¾"	¾"	¾"	¾"	¾"	¾"	¾"
<b>Refrigerant Line Connection Size</b>								
Liquid	⅝"	⅝"	⅝"	⅝"	⅝"	⅝"	⅝"	⅝"
Suction	¾"	¾"	¾"	¾"	¾"	⅞"	⅞"	⅞"
<b>Electrical Data</b>								
Voltage	208 / 230	208 / 230	208 / 230	208 / 230	208 / 230	208 / 230	208 / 230	208 / 230
Min Circuit Ampacity	3 / 3	3 / 3	3 / 3	4 / 4	4 / 4	4 / 4	5 / 5	6 / 6
Max. Overcurrent Device (amps)	15 / 15	15 / 15	15 / 15	15 / 15	15 / 15	15 / 15	15 / 15	15 / 15
Min. / Max VAC	197 / 253	197 / 253	197 / 253	197 / 253	197 / 253	197 / 253	197 / 253	197 / 253
Blower Motor FLA/ HP	1.9 / ⅓	1.9 / ⅓	1.9 / ⅓	3.0 / ⅓	3.0 / ⅓	3.1 / ⅓	3.5 / ½	4.6 / ¾
Ship Weight (lbs)	98	98	103	115	115	117	154	154

\*Airflow rate @.3 static

# PRODUCT SPECIFICATIONS

# ASPT\*\*14\*\*

	ASPT 24B14*	ASPT 30C14*	ASPT 36C14*	ASPT 42C14*	ASPT 48C14*	ASPT 42D14*	ASPT 48D14*	ASPT 60D14*
<b>Nominal Ratings</b>								
Cooling (Btu/h)	24,000	30,000	36,000	36,000	42,000	42,000	48,000	60,000
Airflow Rate CFM *								
T1	520	540	890	865	1275	1110	1250	1400
T2	600	625	995	980	1400	1250	1400	1600
T3	660	720	1090	1,070	1500	1355	1515	1745
T4	775	810	1205	1,190	1585	1440	1635	1995
T5	975	1,400	1425	1,520	1680	1780	1825	2160
<b>Blower</b>								
Diameter	9½"	10⅝"	10⅝"	10⅝"	10⅝"	10⅝"	10⅝"	11⅝"
Width	6"	8"	8"	10⅝"	10⅝"	10⅝"	10⅝"	10⅝"
Coil Drain Connect FPT	¾"	¾"	¾"	¾"	¾"	¾"	¾"	¾"
<b>Refrigerant Line</b>								
<b>Connection Size</b>								
Liquid	⅜"	⅜"	⅜"	⅜"	⅜"	⅜"	⅜"	⅜"
Suction	¾"	⅞"	⅞"	⅞"	⅞"	⅞"	⅞"	⅞"
<b>Electrical Data</b>								
Voltage	208 / 230	208 / 230	208 / 230	208 / 230	208 / 230	208 / 230	208 / 230	208 / 230
Min Circuit Ampacity	3/3	4 / 4	4 / 4	4 / 4	7/7	6/6	8/8	8/8
Max. Overcurrent Device	15 / 15	15 / 15	15 / 15	15 / 15	15/15	15 / 15	15 / 15	15 / 15
Min. / Max VAC	197 / 253	197 / 253	197 / 253	197 / 253	197/253	197 / 253	197 / 253	197 / 253
Blower Motor FLA/ HP	2.18/ 3/4	3.15/ 3/4	3.15/ 3/4	3.15/ 3/4	5.4/ 3/4	4.84/ 3/4	6.65/ 1	6.65/ 1
<b>Ship Weight (lbs)</b>	100	118	118	125	125	167	167	167

\*Airflow rate @.3 static

**Note:** Assumes dry coil; SCFM correction for wet coil = 4% (208V / 240V)

# PRODUCT SPECIFICATIONS

# ASUF\*\*14\*\*

	ASUF 29B14*	ASUF 39C14*	ASUF 49C14*	ASUF 59D14*
<b>Nominal Ratings</b>				
Cooling (Btu/h)	24,000	36,000	49,000	60,000
<b>Airflow Rate CFM *</b>				
T1	520	890	1375	1400
T2	600	995	1525	1600
T3	660	1090	1620	1745
T4	775	1205	1715	1995
T5	975	1425	1800	2160
<b>Blower</b>				
Diameter	9½"	10⅝"	10⅝"	11 15/16"
Width	6"	8"	10⅝"	10⅝"
Coil Drain Connect FPT	¾"	¾"	¾"	¾"
<b>Refrigerant Line Connection Size</b>				
Liquid	⅜"	⅜"	⅜"	⅜"
Suction	¾"	⅞"	⅞"	⅞"
<b>Electrical Data</b>				
Voltage	208 / 230	208 / 230	208 / 230	208 / 230
Min Circuit Ampacity	3 / 3	4 / 4	4 / 4	6 / 6
Max. Overcurrent Device (amps)	15 / 15	15 / 15	15 / 15	15 / 15
Min. / Max VAC	197 / 253	197 / 253	197 / 253	197 / 253
Blower Motor FLA/ HP	2.7 / ¾	3.2 / ¾	5.4 / ¾	6.7 / 1
<b>Ship Weight (lbs)</b>	100	118	118	167

\*Airflow rate @.3 static

# BLOWER PERFORMANCE DATA

# ARPT\*\*14\*\*

Model Number	Blower Speed	Static Pressure (in w.c)						
		0.1	0.2	0.3	0.4	0.5	0.6	0.7
ARPT18B14	High	1185	1125	1065	1010	985	910	780
	Medium	900	850	825	785	715	670	610
	Low	630	605	560	525	495	445	355
ARPT24B14	High	1185	1125	1065	1010	985	910	780
	Medium	900	850	825	785	715	670	610
	Low	630	605	560	525	495	445	355
ARPT30B14	High	1145	1085	1020	950	900	845	765
	Medium	870	820	775	745	705	655	580
	Low	615	585	565	535	490	435	345
ARPT36C14	High	1580	1515	1445	1395	1345	1240	1155
	Medium	1385	1350	1300	1250	1170	1095	1005
	Low	1260	1205	1175	1105	1040	975	865
ARPT36D14	High	1815	1770	1705	1640	1555	1450	1355
	Medium	1580	1525	1485	1420	1350	1275	1165
	Low	1220	1180	1140	1085	1030	950	865
ARPT42D14	High	1990	1915	1810	1765	1690	1585	1435
	Medium	1655	1605	1555	1480	1295	1200	1060
	Low	1480	1420	1350	1290	1185	1100	1045
ARPT48D14	High	1960	1905	1845	1780	1715	1645	1570
	Medium	1600	1545	1495	1435	1360	1290	1215
	Low	1395	1340	1280	1220	1150	1090	1020
ARPT60D14	High	2205	2140	2080	2010	1945	1870	1795
	Medium	1985	1935	1865	1815	1755	1695	1635
	Low	1600	1555	1505	1455	1405	1345	1295

### AIRFLOW DATA (CFM) ARPT\*\*14\*\*

**Notes:** • Airflow data indicated is at 230V without air filter in place.

• The chart is for information only. For satisfactory operation, external static pressure must not exceed value shown on rating plate. The shaded area indicates ranges in excess of maximum design external static pressure.

• Use the CFM adjustment factors of 0.98 for horizontal left and 0.96 for horizontal right & downflow orientations.



# BLOWER PERFORMANCE DATA

# ARUF\*\*14\*\*

Model Number	Blower Speed	Static Pressure (in w.c)						
		0.1	0.2	0.3	0.4	0.5	0.6	0.7
ARUF18B14*	High	1150	1095	1045	1025	950	865	775
	Medium	890	855	835	775	715	665	605
	Low	640	605	565	530	485	440	360
ARUF24B14*	High	1150	1095	1045	1025	950	865	775
	Medium	890	855	835	775	715	665	605
	Low	640	605	565	530	485	440	360
ARUF30B14*	High	1145	1085	1020	950	900	845	765
	Medium	870	820	775	745	705	655	580
	Low	615	585	565	535	490	435	345
ARUF30C14*	High	1485	1435	1385	1345	1275	1205	1125
	Medium	1300	1270	1235	1195	1130	1060	955
	Low	1040	1015	980	930	865	790	705
ARUF36C14*	High	1485	1435	1385	1345	1275	1205	1125
	Medium	1300	1270	1235	1195	1130	1060	955
	Low	1040	1015	980	930	865	790	705
ARUF 42C14AA	High	1580	1530	1465	1400	1330	1255	1165
	Medium	1395	1340	1290	1235	1170	1095	1000
	Low	1095	1045	1000	950	895	820	725
ARUF 42C14AB	High	1655	1590	1515	1430	1340	1225	1080
	Medium	1435	1370	1300	1220	1150	1025	925
	Low	1115	1040	995	930	845	770	675
ARUF48D14*	High	1990	1915	1810	1765	1690	1585	1435
	Medium	1655	1605	1555	1480	1295	1200	1060
	Low	1480	1420	1350	1290	1185	1100	1045
ARUF60D14*	High	2235	2175	2125	2050	1960	1825	1720
	Medium	2030	1970	1885	1800	1690	1600	1495
	Low	1615	1535	1455	1355	1270	1185	1090

### AIRFLOW DATA (CFM) ARUF\*\*14\*\*

**Notes:** • Airflow data indicated is at 230V without air filter in place.

• The chart is for information only. For satisfactory operation, external static pressure must not exceed value shown on rating plate. The shaded area indicates ranges in excess of maximum design external static pressure.

• Use the CFM adjustment factors of 0.98 for horizontal left and 0.96 for horizontal right & downflow orientations.

# BLOWER PERFORMANCE DATA

# ASPT\*\*14\*\*

Model Number	Blower Speed Tap	Static Pressure (in w.c)									
		0.1	0.2	0.3	0.4	0.5	0.6	0.7	0.8	0.9	1
ASPT24B14	1	570	540	520	480	450	415	370	305	270	240
	2	650	605	600	570	530	500	460	425	380	330
	3	740	690	660	650	615	570	525	480	440	405
	4	855	810	775	755	750	720	690	650	620	575
	5	1050	1005	975	940	910	900	885	880	845	820
ASPT30C14	1	610	580	540	445	390	330	285	240	205	160
	2	705	670	625	570	545	465	425	385	325	270
	3	785	740	720	660	640	580	515	475	440	370
	4	880	845	810	805	740	700	660	595	550	515
	5	1440	1440	1400	1380	1350	1330	1295	1275	1245	1205
ASPT36C14	1	960	905	890	810	760	720	665	620	550	485
	2	1060	1010	995	920	875	835	790	745	690	615
	3	1150	1100	1090	1025	990	945	905	860	810	750
	4	1250	1220	1205	1145	1110	1070	1035	990	940	885
	5	1470	1440	1425	1405	1375	1260	1315	1280	1245	1205
ASPT42C14	1	950	925	865	815	730	675	660	600	545	---
	2	1075	1025	980	930	875	785	730	690	650	---
	3	1160	1115	1070	1025	975	905	815	770	715	---
	4	1275	1235	1190	1145	1100	1040	975	875	835	---
	5	1600	1560	1520	1480	1430	1390	1345	1290	1245	---
ASPT48C14	1	1365	1305	1275	1225	1175	1110	1070	1020	995	---
	2	1490	1455	1405	1360	1305	1255	1205	1160	1115	---
	3	1580	1540	1500	1455	1400	1350	1300	1260	1210	---
	4	1670	1635	1585	1545	1495	1445	1395	1365	1315	---
	5	1750	1715	1680	1645	1590	1530	1495	1460	1410	---
ASPT42D14	1	1230	1180	1110	1060	1000	945	885	810	745	685
	2	1365	1310	1250	1190	1140	1090	1030	980	920	855
	3	1460	1410	1355	1305	1255	1210	1155	1115	1060	1010
	4	1545	1490	1440	1375	1330	1295	1245	1200	1150	1100
	5	1865	1825	1780	1745	1695	1645	1610	1570	1520	1475
ASPT48D14	1	1485	1425	1400	1325	1270	1220	1165	1115	1080	1005
	2	1560	1510	1490	1425	1385	1335	1295	1250	1205	1155
	3	1675	1625	1600	1530	1485	1435	1390	1345	1295	1245
	4	1820	1770	1745	1685	1640	1595	1555	1510	1470	1420
	5	2225	2180	2160	2085	2060	2010	1970	1930	1895	1850
ASPT60D14	1	1485	1425	1400	1325	1270	1220	1165	1115	1080	1005
	2	1675	1625	1600	1530	1485	1435	1390	1345	1295	1245
	3	1820	1770	1745	1685	1640	1595	1555	1510	1470	1420
	4	2060	2010	1995	1925	1880	1845	1800	1760	1720	1680
	5	2225	2180	2160	2085	2060	2010	1970	1930	1895	1850

### AIRFLOW DATA (CFM) ASPT\*\*14\*\*

**Notes:** • Airflow data indicated is at 230V without air filter in place.

- The chart is for information only. For satisfactory operation, external static pressure must not exceed value shown on rating plate. The shaded area indicates ranges in excess of maximum design external static pressure.
- Use the CFM adjustment factors of 0.98 for horizontal left and 0.96 for horizontal right & downflow orientations.

# BLOWER PERFORMANCE DATA

# ASUF\*\*14\*\*

Model Number	Blower Speed Tap	Static Pressure (in w.c)									
		0.1	0.2	0.3	0.4	0.5	0.6	0.7	0.8	0.9	1
ASUF29B14	1	570	540	520	480	450	415	370	305	270	240
	2	650	605	600	570	530	500	460	425	380	330
	3	740	690	660	650	615	570	525	480	440	405
	4	855	810	775	755	750	720	690	650	620	575
	5	1050	1005	975	940	910	900	885	880	845	820
ASUF39C14	1	960	905	890	810	760	720	665	620	550	485
	2	1060	1010	995	920	875	835	790	745	690	615
	3	1150	1100	1090	1025	990	945	905	860	810	750
	4	1250	1220	1205	1145	1110	1070	1035	990	940	885
	5	1470	1440	1425	1405	1375	1260	1315	1280	1245	1205
ASUF49C14	1	1425	1405	1375	1340	1305	1265	1215	1155	1115	1070
	2	1560	1545	1525	1490	1455	1410	1380	1325	1275	1225
	3	1670	1645	1620	1595	1550	1520	1485	1445	1405	1350
	4	1760	1745	1715	1685	1655	1625	1585	1550	1515	1470
	5	1845	1820	1800	1775	1740	1705	1675	1640	1605	1575
ASUF59D14	1	1485	1425	1400	1325	1270	1220	1165	1115	1080	1005
	2	1675	1625	1600	1530	1485	1435	1390	1345	1295	1245
	3	1820	1770	1745	1685	1640	1595	1555	1510	1470	1420
	4	2060	2010	1995	1925	1880	1845	1800	1760	1720	1680
	5	2225	2180	2160	2085	2060	2010	1970	1930	1895	1850

## AIRFLOW DATA (CFM) ASUF\*\*14\*\*

**Notes:** • Airflow data indicated is at 230V without air filter in place.

• The chart is for information only. For satisfactory operation, external static pressure must not exceed value shown on rating plate. The shaded area indicates ranges in excess of maximum design external static pressure.

• Use the CFM adjustment factors of 0.98 for horizontal left and 0.96 for horizontal right & downflow orientations.

# WIRING DIAGRAMS

# ARPT\*\*14\*\*/ARUF\*\*14\*\*



**WARNING**

**HIGH VOLTAGE!**  
**DISCONNECT ALL POWER BEFORE SERVICING OR INSTALLING THIS UNIT. MULTIPLE POWER SOURCES MAY BE PRESENT. FAILURE TO DO SO MAY CAUSE PROPERTY DAMAGE, PERSONAL INJURY OR DEATH.**



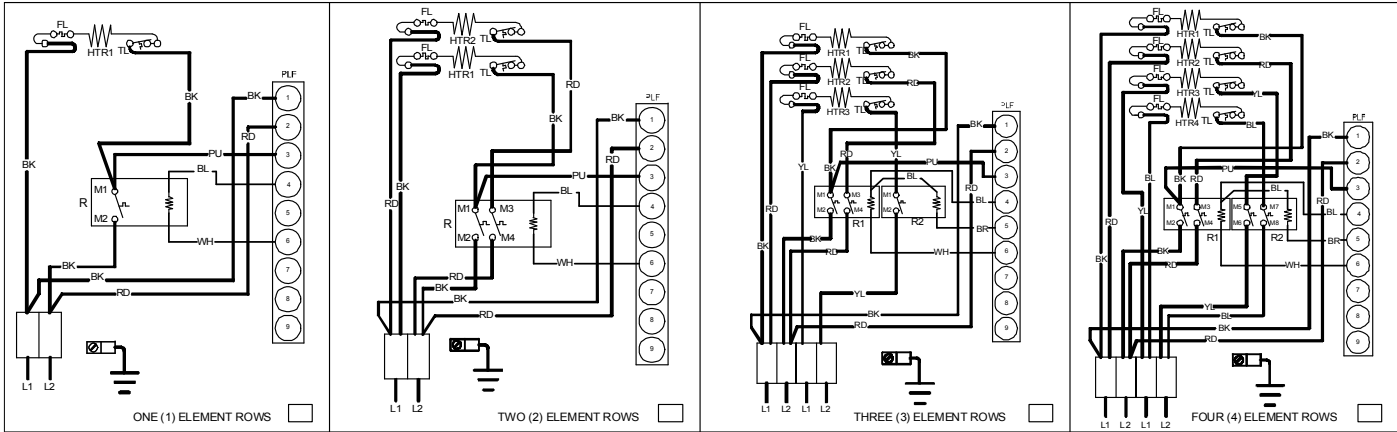

NOTE: WHEN INSTALLING HEATER KIT, ENSURE SPEED TAP IS NOT BELOW MINIMUM BLOWER SPEED (MBS) SPECIFIED FOR THE AIR HANDLER/HEATER KIT COMBINATION ON THIS UNIT'S SERIAL PLATE. AFTER INST ALLING OPTIONAL HEAT KIT, MARK A "X" IN THE  PROVIDED ABOVE. MARK ACCORDING TO THE NUMBER OF HEATER ELEMENT ROWS INSTALLED. NO MARK INDICATES NO HEAT KIT INSTALLED. 5 ELEMENT ROWS DATA SUPPLIED WITH HEATER KIT.

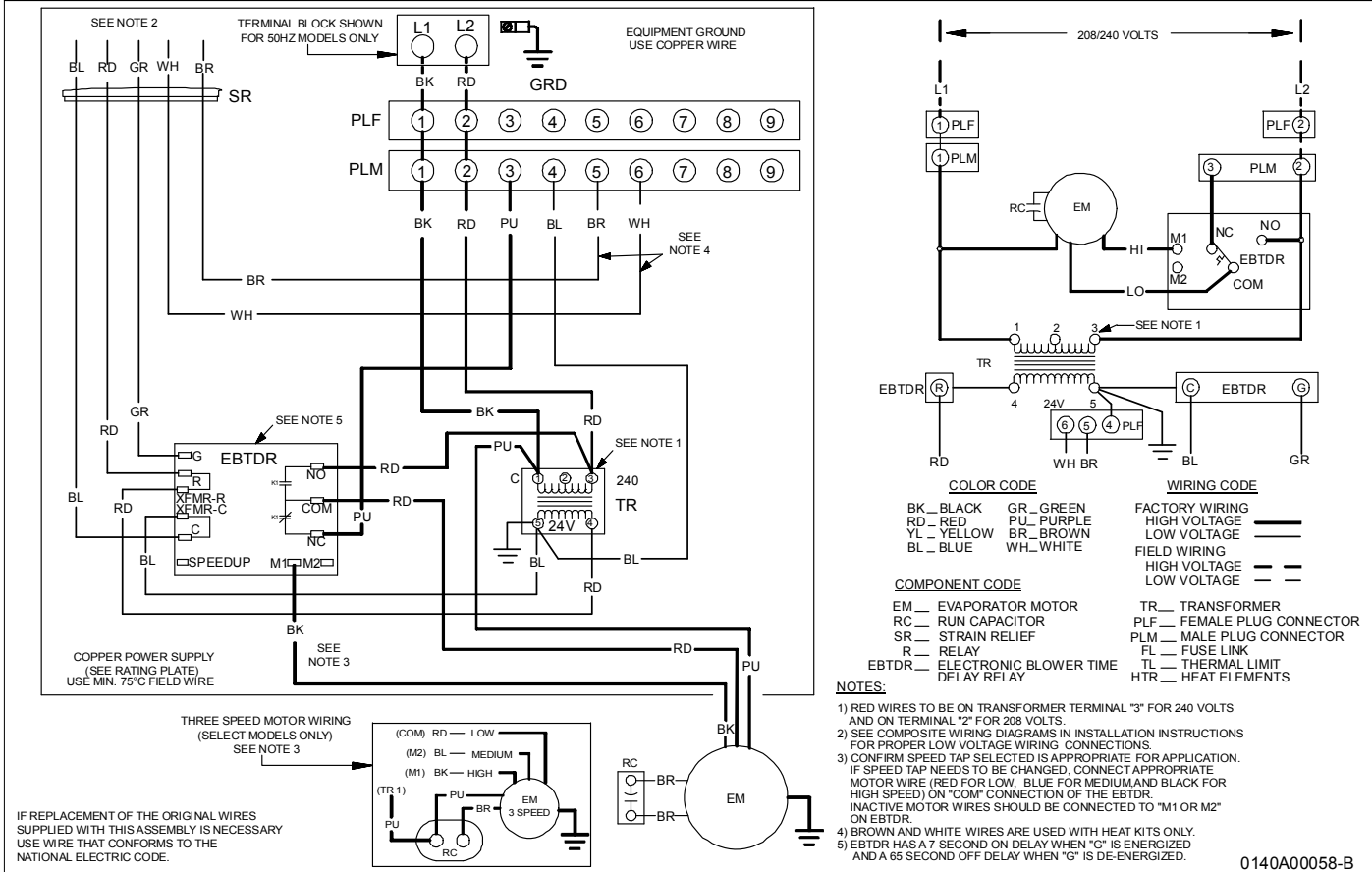

0140A00058-B

Wiring is subject to change. Always refer to the wiring diagram on the unit for the most up-to-date wiring.

# WIRING DIAGRAMS

# ASPT\*\*14\*\*/ASUF\*\*14\*\*

WARNING

HIGH VOLTAGE!  
DISCONNECT ALL POWER BEFORE SERVICING OR INSTALLING THIS UNIT. MULTIPLE POWER SOURCES MAY BE PRESENT. FAILURE TO DO SO MAY CAUSE PROPERTY DAMAGE, PERSONAL INJURY OR DEATH.

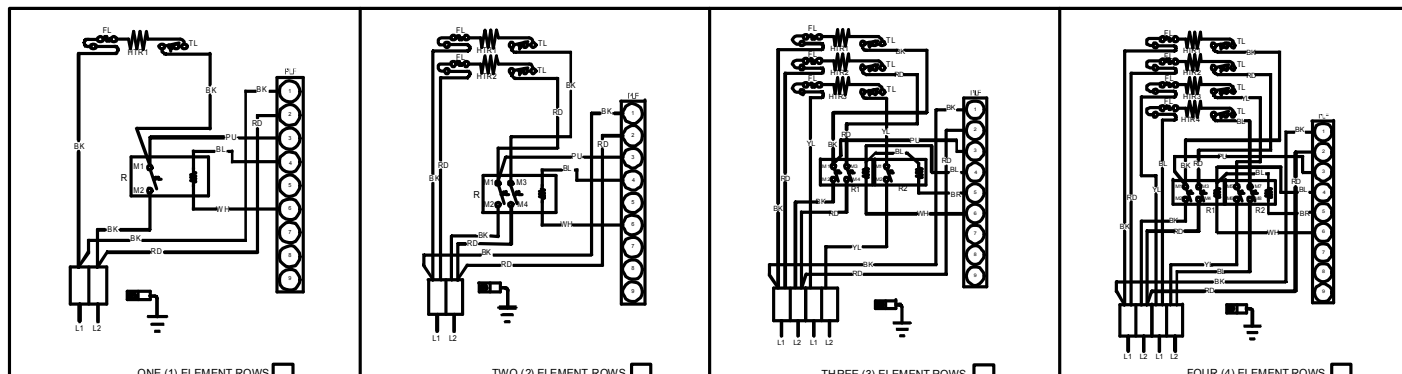

NOTE: WHEN INSTALLING HEATER KIT, ENSURE SPEED TAP DOES NOT EXCEED MINIMUM BLOWER SPEED (MBS) SPECIFIED FOR THE AIRHANDLER/HEATER KIT COMBINATION ON THIS UNIT'S S&R PLATE. AFTER INSTALLING OPTIONAL HEAT KIT, MARK A "X" IN THE BOX PROVIDED ABOVE. MARK ACCORDING TO NUMBER OF HEATER ELEMENT ROWS INSTALLED. NO MARK INDICATES NO HEAT KIT INSTALLED.

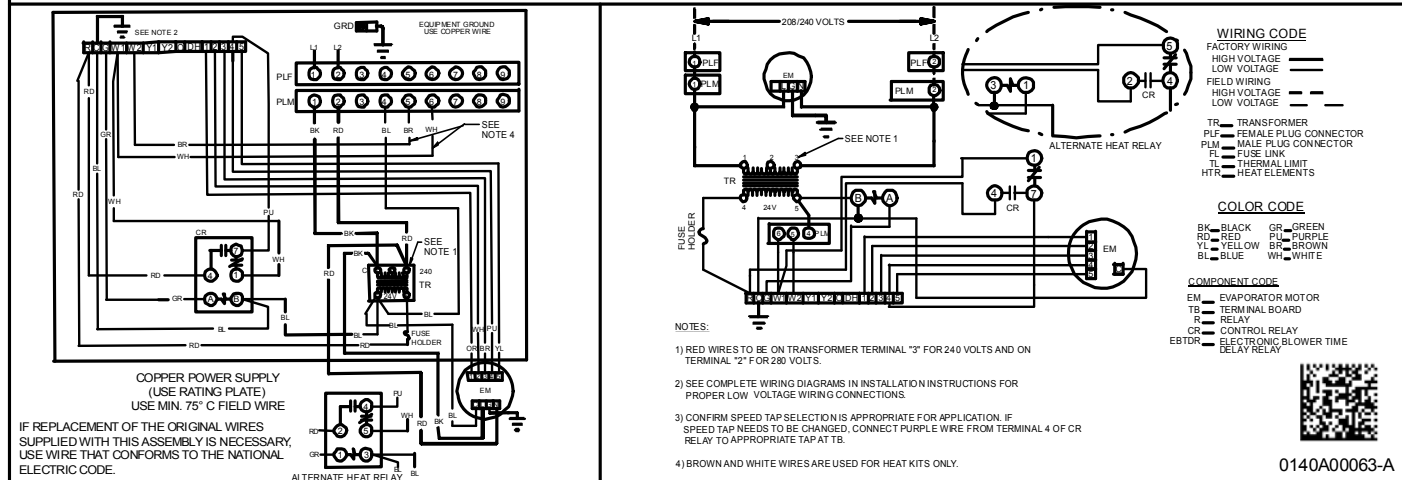

0140A00063-A

# WIRING DIAGRAMS



**WARNING**

**HIGH VOLTAGE!**  
**DISCONNECT ALL POWER BEFORE SERVICING OR INSTALLING THIS UNIT. MULTIPLE POWER SOURCES MAY BE PRESENT. FAILURE TO DO SO MAY CAUSE PROPERTY DAMAGE, PERSONAL INJURY OR DEATH.**



## 3-Phase Heat Kit

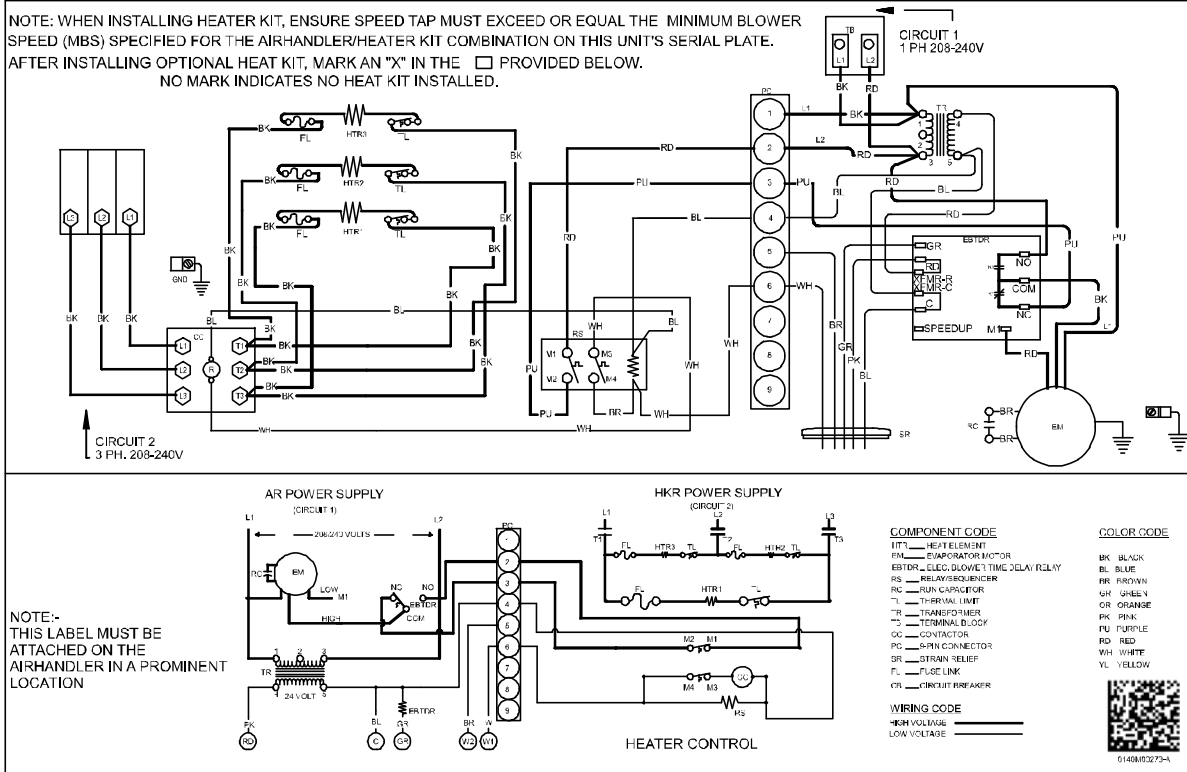

## 25kW Heat Kit

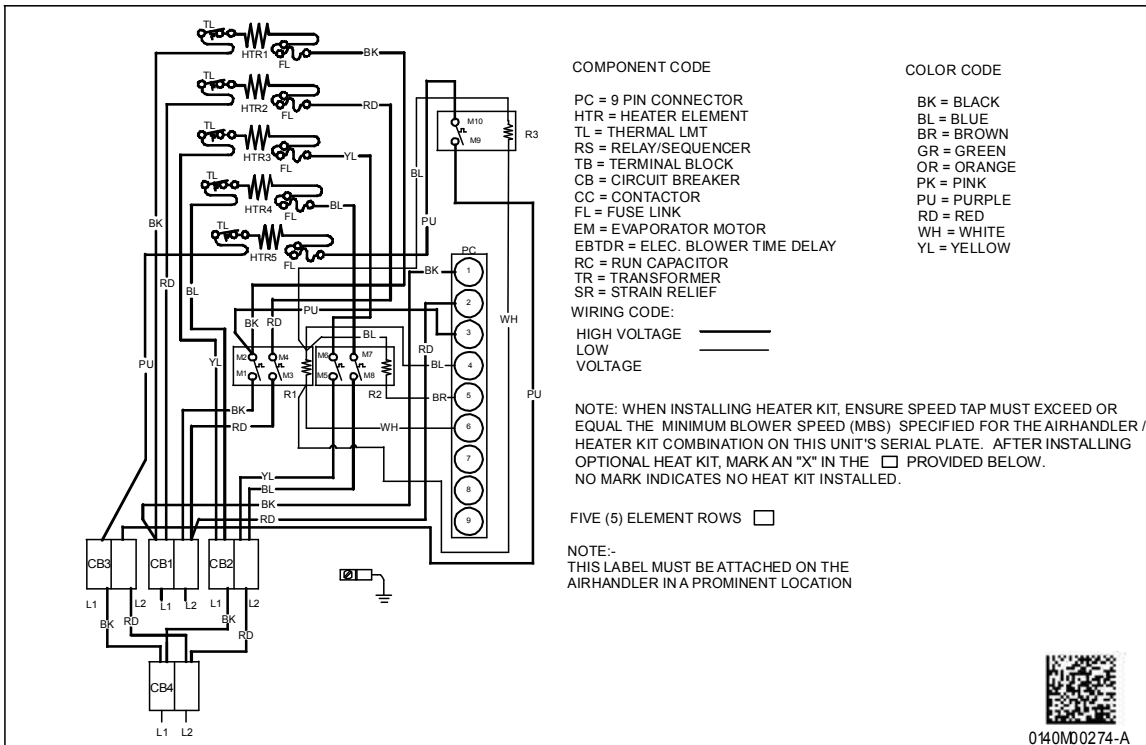

Wiring is subject to change. Always refer to the wiring diagram on the unit for the most up-to-date wiring.