

OEM

OPERATING AND SERVICE MANUAL

TM50-1 AND TM50-2 THINLINE™  
5-1/4-INCH FLEXIBLE DISK DRIVES  
48 TRACKS PER INCH

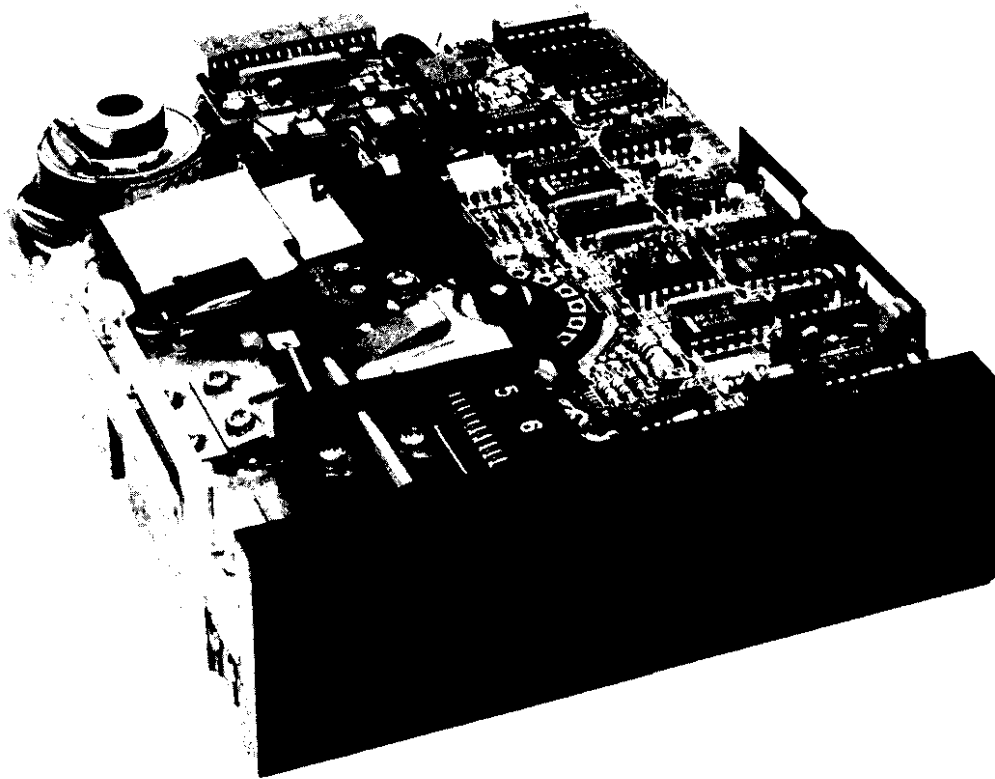

TANDON CORPORATION  
20320 PRAIRIE STREET  
CHATSWORTH, CALIFORNIA 91311

© COPYRIGHT 1983 TANDON CORPORATION

## NOTICE

This document, and the information contained herein, is copyright by Tandon Corporation and may not be duplicated or reproduced, in whole or in part, without the prior written approval of Tandon Corporation.

This document is intended to provide the user with detailed information adequate for the efficient installation, operation, and service of the equipment involved.

However, while every effort has been made to keep the information contained herein current and accurate as of the date of publication, no guarantee is given or implied as to its accuracy.

# CONTENTS

<u>Section Number</u>	<u>Title</u>	<u>Page Number</u>
SECTION 1	GENERAL DESCRIPTION	
	Introduction . . . . .	1-1
1.1	Scope Of The Document . . . . .	1-1
1.2	Purpose Of The Drive . . . . .	1-1
1.3	Major Features . . . . .	1-1
	Write Protect . . . . .	1-1
	Daisy Chain Capability . . . . .	1-2
	Internal Trim Erase . . . . .	1-2
	Industry Standard Interface Compatibility . . . . .	1-2
	Track 0 Sensor . . . . .	1-2
	Index Sensor . . . . .	1-2
	Activity Indicator . . . . .	1-2
	Compact Size . . . . .	1-2
1.4	Functional Description . . . . .	1-2
1.5	Physical Description . . . . .	1-3
SECTION 2	PRODUCT SPECIFICATIONS	
	Introduction . . . . .	2-1
2.1	Mechanical Specifications . . . . .	2-1
2.2	Electrical and Operational Specifications . . . . .	2-1
2.3	Reliability Specifications . . . . .	2-1
2.4	Environmental Specifications . . . . .	2-1
SECTION 3	OPERATION	
	Introduction . . . . .	3-1
3.1	Unpacking The Drive . . . . .	3-1
3.2	Preinstallation Checkout . . . . .	3-1
3.3	Mounting The Drive . . . . .	3-2
	Dust Cover . . . . .	3-2
	Cooling . . . . .	3-2
3.4	Interface Connections . . . . .	3-3
	Input Control Lines . . . . .	3-4
	Output Control Lines . . . . .	3-6
	Typical Interface Characteristics . . . . .	3-7
3.5	D. C. Power . . . . .	3-7
3.6	Drive Address and Option Patching . . . . .	3-8
	DS0 Through DS3 Jumpers . . . . .	3-8
	MX Jumper . . . . .	3-8

# CONTENTS

<u>Section Number</u>	<u>Title</u>	<u>Page Number</u>
	Motor Select Jumper . . . . .	3-11
	Write Protect (W1) . . . . .	3-11
	Head Type (W2, W3) . . . . .	3-11
	W4 Through W8 . . . . .	3-11
	Side Select (W9) . . . . .	3-11
	Motor On (W1) . . . . .	3-12
3.7	Diskettes . . . . .	3-12
	Loading The Diskette . . . . .	3-12
	Write Protect Tab . . . . .	3-13
	Diskette Handling and Storage . . . . .	3-13
SECTION 4           THEORY OF OPERATION		
	Introduction . . . . .	4-1
4.1	Data Recording . . . . .	4-1
4.2	Components Of The Drive . . . . .	4-4
4.3	Generate and Interpret Control Signals . . . . .	4-4
	Index Sensor . . . . .	4-4
	Write Protect Switch . . . . .	4-5
	Track 0 Sensor . . . . .	4-5
	Drive Select . . . . .	4-6
4.4	Read/Write Head Positioner . . . . .	4-7
	Step and Direction . . . . .	4-7
	Stepper Motor Control . . . . .	4-8
	Stepper Motor . . . . .	4-8
4.5	Read/Write Data . . . . .	4-8
	Read/Write Head Assembly . . . . .	4-8
	Side Select Circuits . . . . .	4-8
	Write/Erase Circuits . . . . .	4-9
	Read Data Circuits . . . . .	4-12
4.6	Spindle Control . . . . .	4-12
	Spindle Motor and Spindle Assembly . . . . .	4-13
	Spindle Motor Enable Circuit . . . . .	4-13
	Spindle Motor Control Circuit . . . . .	4-14
	Diskette Enabled Switch (Door Lever) . . . . .	4-14
SECTION 5           MAINTENANCE CHECKS AND ADJUSTMENTS		
	Introduction . . . . .	5-1
5.1	Visual Inspection . . . . .	5-1
5.2	Equipment Required . . . . .	5-2
5.3	Power Drive Select Check . . . . .	5-3
5.4	Write Protect Switch Check and Adjustment . . . . .	5-4
	Write Protect Switch Check . . . . .	5-4
	Write Protect Switch Adjustment . . . . .	5-4
5.5	Drive Motor Speed Check and Adjustment . . . . .	5-4
	Drive Motor Check . . . . .	5-4
	Drive Motor Adjustment . . . . .	5-5

## CONTENTS

<u>Section Number</u>	<u>Title</u>	<u>Page Number</u>
5.6	Radial Track Alignment Check and Adjustment . . . . .	5-6
	Radial Track Alignment Check . . . . .	5-7
	Radial Track Alignment Adjustment . . . . .	5-10
5.7	Index Checks and Adjustment . . . . .	5-10
	Index-To-Data Pulse Checks . . . . .	5-11
	Index Sensor Adjustment . . . . .	5-13
5.8	Azimuth Check . . . . .	5-13
5.9	Track 0 Sensor Check and Adjustment . . . . .	5-15
	Track 0 Sensor Check . . . . .	5-15
	Track 0 Sensor Adjustment . . . . .	5-16
5.10	Track 0 Stop Adjustment . . . . .	5-16
5.11	Head Output Check . . . . .	5-17
5.12	Cone Centering Check . . . . .	5-19
5.13	Compliance Check and Adjustment (Single-Sided Drives) . . . . .	5-20
	Compliance Check . . . . .	5-20
	Compliance Adjustment . . . . .	5-21
<b>SECTION 6   REMOVAL AND INSTALLATION</b>		
	Control and Data Circuit Board . . . . .	6-2
	Servo Circuit Board . . . . .	6-2
	Chassis Shield, Control and Data Circuit Board . . . . .	6-3
	Diskette Lever Assembly . . . . .	6-3
	Front Panel . . . . .	6-5
	Power Input Plug and Bracket . . . . .	6-5
	Write Protect Switch . . . . .	6-6
	Write Protect Sensor . . . . .	6-7
	Stepper Band . . . . .	6-8
	Stepper Motor . . . . .	6-10
	Upper Plate Assembly . . . . .	6-12
	Track 0 Sensor and Track 0 Stop Block . . . . .	6-14
	Head Module . . . . .	6-16
	Drive Belt . . . . .	6-17
	Drive Motor . . . . .	6-18
<b>APPENDIX A   Recommended Spare Parts and Major Assemblies</b>		
APPENDIX A	Recommended Spare Parts and Major Assemblies	A-1
<b>APPENDIX B   Circuit Board Schematics and Drawings</b>		
APPENDIX B	Circuit Board Schematics and Drawings . . . . .	B-1

# ILLUSTRATIONS

## FIGURES

<u>Figure Number</u>	<u>Title</u>	<u>Page Number</u>
1-1	Disk Drive . . . . .	1-4
2-1	Disk Drive Outline Drawing . . . . .	2-2
3-1	Electrical Interface Characteristics . . . . .	3-7
3-2	Control and Data Timing Requirements . . . . .	3-9
3-3	Logic Board With Programmable Shunts and Option Patching Locations . . . . .	3-10
3-4	Recording Media . . . . .	3-12
3-5	Write Protect Tab . . . . .	3-13
3-6	Diskette Care and Handling . . . . .	3-14
4-1	Electromagnetic Core . . . . .	4-1
4-2	FM Recording Magnetization Profiles . . . . .	4-2
4-3	Read Timing Diagram . . . . .	4-2
4-4	Interconnect Block Diagram . . . . .	4-3
4-5	Soft Sector Index Pulse . . . . .	4-5
4-6	Track 0 Timing . . . . .	4-6
4-7	Write Data Circuit Block Diagram . . . . .	4-10
4-8	Write Operation Timing Diagram . . . . .	4-11
4-9	Read Circuit Block Diagram . . . . .	4-13
4-10	Servo Circuit Board . . . . .	4-14
5-1	Logic Circuit Board With Test Points . . . . .	5-2
5-2	Write Protect Switch Adjustment . . . . .	5-5
5-3	Location Of R15 Speed Control Potentiometer . . . . .	5-6
5-4	Bottom View Of Drive . . . . .	5-6
5-5	Hub Center Line and Track Location . . . . .	5-7
5-6	Cats Eye Patterns . . . . .	5-8
5-7	Stepper Motor Retaining Screws and Camming Bars . . . . .	5-10
5-8	Index-To-Data Pulse . . . . .	5-11
5-9	Index Sensor's Retaining Screw and Adjustment . . . . .	5-12
5-10	Optimum Head Azimuth Alignment . . . . .	5-14
5-11	Head Azimuth Alignment Of Acceptable Lower Limits . . . . .	5-14
5-12	Head Azimuth Alignment Of Acceptable Upper Limits . . . . .	5-15
5-13	Track 0 Stop . . . . .	5-18
5-14	Upper Arm and Compliance Spring . . . . .	5-21
6-1	Control and Data Circuit Board . . . . .	6-4
6-2	Servo Circuit Board . . . . .	6-4
6-3	Diskette Lever Assembly . . . . .	6-4
6-4	Power Input Plug and Bracket . . . . .	6-5
6-5	Stepper Band . . . . .	6-10
6-6	Stepper Motor . . . . .	6-11
6-7	Upper Plate Assembly . . . . .	6-13
6-8	Track 0 Sensor and Stop Block . . . . .	6-15
6-9	Drive Motor . . . . .	6-19

TABLES

<u>Table Number</u>	<u>Title</u>	<u>Page Number</u>
2-1	Electrical and Operational Specifications . . .	2-3
2-2	Reliability Specifications . . . . .	2-4
2-3	Environmental Specifications . . . . .	2-5
3-1	Drive Interface Lines and Pin Assignments . . .	3-3
3-2	D. C. Power Connector Pin Assignments . . . . .	3-8

## SECTION 1

### GENERAL DESCRIPTION

#### INTRODUCTION

This document provides required information in order to evaluate and incorporate Tandon's disk drive into a system.

Tandon Corporation's Model Number TM50-1 and TM50-2, 5-1/4-inch flexible drives are compact, low profile drives that may be installed in only one-half the space normally required. They are compact data storage devices that use an ANSI-compatible, industry standard, 5-1/4-inch diskette.

Model Number TM50-1 and TM50-2 drives each 48 tracks per inch. The TM50-2 is a double-sided recording device.

Both drives are capable of reading and writing in single-density format on a diskette, using a propriety read/write head patented by Tandon. The drives have a double density capability when a Modified Frequency Modulated (MFM) or other appropriate recording technique is used. Encoding and decoding of the data is done by the user's controller.

#### 1.1 SCOPE OF THE DOCUMENT

This document contains the major features, physical and functional specifications, mounting and power requirements, the interface, and typical timing characteristics of the TM50-1 and TM50-2 drives.

In addition, there is a theory of operation, checks and adjustment procedures, replacement procedures, assembly drawings, and schematics.

#### 1.2 PURPOSE OF THE DRIVE

The TM50-1 and TM50-2 drives are rotating disk memories designed for random access data entry, storage, and retrieval applications. Typical applications include intelligent terminal controllers, microcomputers, word processing systems, data communication systems, error logging, program loading, and point-of-sale terminals.

#### 1.3 MAJOR FEATURES

##### Write Protect

When a write protected diskette is inserted into the drive, the write electronics are disabled.



### Daisy Chain Capability

The drive provides the address selection and gating functions necessary to daisy chain a maximum of four units at the user's option. The last drive of the daisy chain terminates the interface. The terminations are accomplished by a resistor array plugged into a DIP socket.

### Internal Trim Erase

The drive provides the control signals necessary for proper trim erasure of data.

### Industry Standard Interface Compatibility

The drive is compatible with controllers that use an industry standard interface.

### Track 0 Sensor

The Track 0 sensor is provided to generate a logic level at the drive interface, indicating that the read/write head is positioned at the outermost track.

### Index Sensor

An index sensor is provided to generate electrical pulses at the drive interface coincident with sensing Index/Sector holes on the diskette.

### Activity Indicator

An activity indicator, located on the front panel, is automatically illuminated when the drive is selected.

### Compact Size

The reduced height of the drive enables it to occupy only one-half the mounting space required for a conventional drive.

## 1.4 FUNCTIONAL DESCRIPTION

The drives are fully self-contained, and require no operator intervention during normal operation. Each drive consists of a spindle drive system, a head positioning system, and a read/write system.

When the front latch is opened, access is provided for insertion of a diskette. The diskette is held in place by plastic guide rails. Its location is ensured when the diskette is inserted until a back stop is encountered and the ejection mechanism latches.

Closing the front latch activates the cone clamping mechanism, resulting in accurate centering and clamping of the diskette. The drive hub is held at a constant speed of 300 RPM by a servo-controlled D. C. motor. The head(s) remain in contact with the recording media until the front latch is opened.

The heads are positioned over the desired track by means of a four-phase stepper motor/band assembly and its associated electronics. This positioner uses a one-step rotation to cause a one track linear movement.

Data recovery electronics include a low-level read amplifier, differentiator, zero crossover detector, and digitizing circuits. No data decoding capabilities are provided.

The drive has the following sensors:

1. A Track 0 sensor detects when the head/carriage assembly is positioned at Track 0.
2. An index sensor is positioned to generate a digital signal when an index hole on the diskette is detected. The index sensor distinguishes index and sector holes in a hard-sectored diskette.
3. A write protect sensor disables the write electronics when a write protect tab is applied to the diskette.
4. A motor control switch.

## 1.5 PHYSICAL DESCRIPTION

A representative drive is shown in Figure 1-1. The drive can be mounted in a vertical or horizontal plane. However, the logic circuit board must be on the uppermost side when the drive is mounted horizontally.

The spindle is belt driven by a D. C. motor with an integral tachometer. The servo control circuit and tachometer control the speed of the spindle.

The read/write head assembly is positioned by a split band positioner mounted to a stepper motor. The read/write heads are glass-bonded, ferrite/ceramic structures with a life expectancy of 20,000 operating hours.

Operator access for diskette loading is provided via a horizontal slot located at the front of the drive.

The electronic components of the drive are mounted on two printed circuit boards. The logic circuit board is mounted above the chassis. The motorcontrol circuit board is mounted on the bottom of the chassis. Power and interface signals are routed through connectors plugging directly into the logic circuit board.

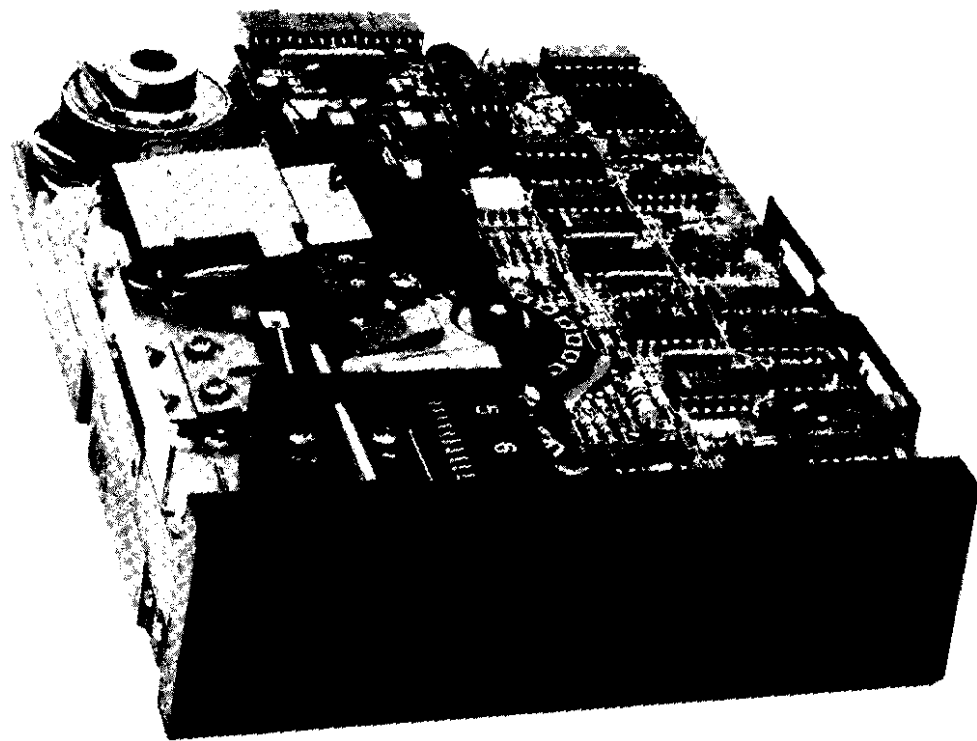

FIGURE 1-1  
DISK DRIVE

SECTION 2

PRODUCT SPECIFICATIONS

INTRODUCTION

This section contains the mechanical, electrical and operational, reliability, and environmental specifications for the TM50-1 and TM50-2 drives.

2.1 MECHANICAL SPECIFICATIONS

The physical dimensions of the drive are located in Figure 2-1.

2.2 ELECTRICAL AND OPERATIONAL SPECIFICATIONS

The electrical and operational specifications are located in Table 2-1.

2.3 RELIABILITY SPECIFICATIONS

The reliability specifications are located in Table 2-2.

2.4 ENVIRONMENTAL SPECIFICATIONS

The environmental specifications are located in Table 2-3.

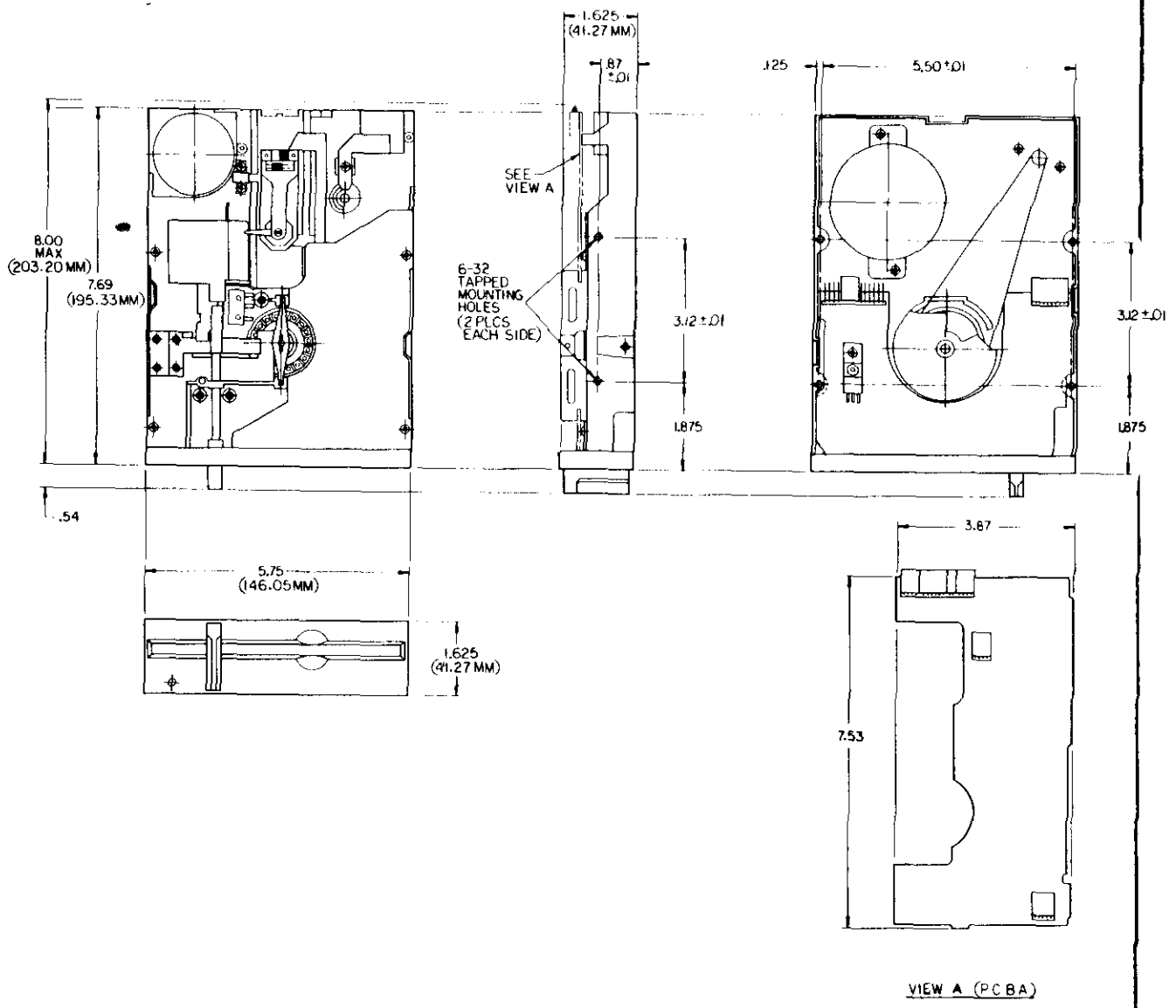

- NOTES:**
1. DIMENSIONS ARE GIVEN IN INCHES. METRIC EQUIVALENTS ARE IN PARENTHESES.
  2. TOLERANCE ON ALL DIMENSIONS IS  $\pm 0.020$  INCH, UNLESS OTHERWISE SPECIFIED.
  3. WEIGHT IS APPROXIMATELY 3 POUNDS.

DISK DRIVE OUTLINE DRAWING

TANDON CORPORATION, CHATSWORTH, CALIFORNIA 91311	179DDD-001 REV. A
--	----------------------

TABLE 2-1

## ELECTRICAL AND OPERATIONAL SPECIFICATIONS

Media	ANSI-compatible, 5-1/4-inch diskette
Media Life (for reference only)	4 x 10 <sup>6</sup> passes per track
Tracks Per Inch	48 TPI, both drives
Tracks Per Drive	
TM50-1	40 Tracks
TM50-2	80 Tracks
Track Spacing	0.529 millimeters, 20.8 milinches
Head Life	20,000 media contact hours
Disk Rotational Speed	300 RPM $\pm$ 1.5 percent
Average Rotational Latency	100 milliseconds
Instantaneous Speed Variation (ISV)	$\pm$ 3 percent
Motor Start Time	One second, maximum
Seek Time, track to track	20 milliseconds
Fast Step Motor (Optional)	6 milliseconds
Head Settling Time	20 milliseconds
Fast Step Motor (Optional)	15 milliseconds
Average Track Access Time, including head settling time	287 milliseconds
Fast Step Motor (Optional)	95 milliseconds
Typical Recording Modes	FM, MFM, MMFM
Data Transfer Rate	250,000 bits per second double density
TANDON CORPORATION, CHATSWORTH, CALIFORNIA 91311	
179DDD-001 REV. A	

TABLE 2-1 (CONTINUED)  
ELECTRICAL AND OPERATIONAL SPECIFICATIONS

<p>Flux Reversals Per Inch (FRPI), inside track</p> <p style="padding-left: 40px;">Both models, Side 0</p> <p style="padding-left: 40px;">TM50-2, Side 1</p> <p>Unformatted Recording Capacity</p> <p style="padding-left: 40px;">TM50-1</p> <p style="padding-left: 40px;">TM50-2</p> <p>D. C. Voltage and Current Requirements</p> <p style="padding-left: 40px;">+5 volts D. C. Power</p> <p style="padding-left: 40px;">+12 volts D. C. Power</p> <p>Shipment</p>	<p style="padding-left: 40px;">5,535 FRPI</p> <p style="padding-left: 40px;">5,877 FRPI</p> <p style="padding-left: 40px;">250 kilobytes per disk</p> <p style="padding-left: 40px;">500 kilobytes per disk</p> <p style="padding-left: 40px;">+5 volts <math>\pm</math> 0.25 volt at 800 milliamperes, maximum, with less than 100 millivolts peak-to-peak ripple.</p> <p style="padding-left: 40px;">+12 volts <math>\pm</math> 0.6 volt, 1.3 amperes, maximum, surge for 50 milliseconds, 800 milliamperes average.</p> <p>When prepared for shipment by Tandon, the drive meets the requirements of NSTA preship- ment test procedure Project 1A.</p>
---	---

TABLE 2-2  
RELIABILITY SPECIFICATIONS

<p>Error Rates, exclusive of external sources, e. g.: electronics, defective and contaminated diskettes</p> <p style="padding-left: 40px;">Soft Errors (Recoverable)</p> <p style="padding-left: 40px;">Hard Errors (Nonrecoverable)</p> <p style="padding-left: 40px;">Seek Errors</p> <p>Mean Time Between Failures</p> <p>Mean Time To Repair</p>	<p style="padding-left: 40px;">One in <math>10^9</math> bits</p> <p style="padding-left: 40px;">One in <math>10^{12}</math> bits</p> <p style="padding-left: 40px;">One in <math>10^6</math> seeks</p> <p style="padding-left: 40px;">8,000 hours, 25 percent duty cycle</p> <p style="padding-left: 40px;">30 minutes</p>
--	--

TANDON CORPORATION, CHATSWORTH, CALIFORNIA 91311

179DDD-001  
REV. A

TABLE 2-3

## ENVIRONMENTAL SPECIFICATIONS

Temperature	
Operating, media dependent	10°C to 46°C, 50°F to 115°F
Nonoperating	-40°C to 71°C, -40°F to 160°F
Relative Humidity	
Operating, noncondensing, media dependent	20-to-80 percent
Nonoperating, noncondensing	5-to-95 percent
Altitude	
Operating or Nonoperating	152.4 meters, 500 feet, below sea level, to 15,240 meters, 50,000 feet, above sea level

TANDON CORPORATION, CHATSWORTH, CALIFORNIA 91311

179DDD-001  
REV. A



INTRODUCTION

This section contains information on how to unpack, check out, install, and operate the TM50-1 and TM50-2 drives.

3.1 UNPACKING THE DRIVE

The drives are shipped in protective containers to minimize the possibility of damage during shipment. The following list is the recommended procedure for unpacking the drive.

1. Place the container on a flat work surface, top side up.
2. Cut the tape that holds the tab in the slot on the front side of the container.

CAUTION

Container may spring open when the tape is cut.

3. Remove the drive from its plastic bag.
4. Inspect the drive for possible damage.
5. Notify the carrier immediately if any damage is found.
6. Save the shipping container for future use.

3.2 PREINSTALLATION CHECKOUT

Before applying power to the drive, the following inspection should be conducted:

1. Check to ensure the front latch rotates easily. It should remain in the open position when rotated fully counterclockwise (horizontal to front panel).

NOTE

When the latch is moved to an open position, the head arm raises.

2. Remove the cardboard shipping insert, and retain for future shipment.
3. Ensure the front panel is secure.

4. Ensure the drive belt is in place.
5. Manually rotate the drive hub. It should rotate freely.
6. Ensure both circuit boards are secure.
7. Ensure the connectors are firmly seated.

### 3.3 MOUNTING THE DRIVE

The drive has been designed to be mounted horizontally or vertically. When mounted horizontally, the logic circuit board side of the drive must be the top side.

Tapped mounting holes are provided on each side and the bottom of the drive for attachment to user-supplied mounting brackets (Figure 2-1). When installed in either plane, horizontal or vertical, only two mounting screws are required to securely hold the drive in place.

Two drives may be mounted in a single, full-size drive enclosure, 3.25-inches high. A two-hole mounting scheme per drive is recommended for mounting in a two drive configuration.

Any mounting scheme in which the drive is part of the structural integrity of the enclosure is not permitted. Mounting schemes should allow for adjustable brackets or incorporate resilient members to accommodate tolerances. In addition, it is recommended that mounting schemes include no more than two mounting surfaces.

The drive is manufactured and tested with some critical internal alignments that must be maintained. Hence, it is important that mounting hardware not introduce significant stress on the chassis.

#### Dust Cover

The design of an enclosure should incorporate a means to prevent contamination from loose items, e. g., dust, lint, and paper chad since the drive does not have a dust cover.

#### Cooling

Heat dissipation from a single drive is normally 15 watts, 51 BTU per hour, under high load conditions. When the drive is mounted so the components have access to a free flow of air, normal convection cooling allows operation within the specified temperature range.

When forced air is used, air flow must be directed outward from the drive. Do not intake air through the drive or heads and diskettes.

The use of forced air flow is recommended when two drives are mounted within a single enclosure.

### 3.4 INTERFACE CONNECTIONS

Interface connections for the TM50-1 and TM50-2 drives are made via a user-supplied, thirty-four pin, flat ribbon connector, 3M Part Number 3463-0001 or AMP Part Number 583717-5, using contact Part Number 1-583616-1 for twisted pair or its equivalent. This connector mates directly with the circuit board connector at the rear of the drive. The D. C. power connector has four pins and is located at the rear of the drive. The interface description of the connectors, and the location of each one, is contained in this section. Interface lines are located in Table 3-1. D. C. power connector pin assignments are located in Table 3-2.

The signal wire harness should be of the flat ribbon or twisted pair type, 26-to-28 gauge conductor, compatible with the connector to be used. The recommended cable length is ten feet maximum.

TABLE 3-1		
DRIVE INTERFACE LINES AND PIN ASSIGNMENTS		
Input Control Lines: Controller-To-Disk Drive		
<u>Ground</u>	<u>Pin</u>	<u>Signal</u>
1	2	Connector Clamp
3	4	Spare
5	6	Drive Select 3
9	10	Drive Select 0
11	12	Drive Select 1
13	14	Drive Select 2
15	16	Motor On
17	18	Direction Select
19	20	Step
21	22	Composite Write Data
23	24	Write Enable
31	32	Side Select
Output Control Lines: Disk Drive-To-Controller		
<u>Ground</u>	<u>Pin</u>	<u>Signal</u>
7	8	Index/Sector
25	26	Track 0
27	28	Write Protect
29	30	Composite Read Data
33	34	Connector Clamp

## Input Control Lines

### Drive Select Lines

The Drive Select lines provide a means of selecting and deselecting a drive. These four lines select one of the four drives attached to the controller.

When the signal logic level is true (low), the drive electronics are activated, and the drive is conditioned to respond to Step or Read/Write commands. A Drive Select line must remain stable in the true (low) state until a Step or Read/Write command is completed. When the signal line logic level is false (high), the input control lines and output status lines are disabled.

The drive address is determined by a select shunt on the logic circuit board. Drive Select lines 0 through 3 provide a means of daisy chaining a maximum of four drives to a controller. Only one can be true (low) at a time. An undefined operation results if two or more drives are assigned the same address or if two or more Drive Select lines are in the true (low) state simultaneously.

### Motor On

When this signal is true (low), the drive motor accelerates to its nominal speed of 300 RPM, and stabilizes at this speed in less than one second. When the signal line logic level goes false (high), the drive decelerates to a stop. This signal is not gated with Drive Select.

### Direction Select and Step Lines (Two Lines)

When the drive is selected, a true (low) pulse on the Step line, with a time duration greater than 200 nanoseconds, initiates the access motion. The direction of motion is determined by the logic state of the Direction Select line when a step pulse is issued. The motion is toward the center of the disk if the Direction Select line is in the true (low) state. The direction of motion is away from the center of the disk if the Direction Select line is in the false (high) state.

To ensure proper positioning, the Direction Select line should be stable at least 100 nanoseconds prior to issuing a corresponding step pulse, and remain true (low) 100 nanoseconds after it.

The access motion is initiated on the trailing edge of the step pulse. The time period between consecutive trailing edges of step pulses should be at least 20 milliseconds.

The drive electronics ignore step pulses when one of three conditions exists:

1. The write enable is true (low).
2. The direction select is false (high), and the head is positioned at Track 0.
3. The drive is not selected.

#### Composite Write Data

When the drive is selected, this interface line provides the bit serial composite write data pulses that control the switching of the write current in the selected head. The write electronics must be conditioned for writing by the Write Enable line.

For each high-to-low transition on the Composite Write Data line, a flux change is produced at the write head gap. This causes a flux change to be recorded on the media.

When a single-density (FM) type encoding technique is used in which data and clock form the combined Write Data signal, it is recommended that the repetition of the high-to-low transitions, while writing all zeros, be equal to one-half percent, and the repetition of the high-to-low transitions, when writing all ones, be equal to the maximum data rate, 250 kilohertz  $\pm$  0.1 percent.

Host controllers may implement write precompensation circuits that recognize worst case patterns and adjust the write data waveform. Although a value cannot be specified for write precompensation, Tandon suggests a value of 250 nanoseconds for systems using MFM double density recording format.

#### Write Enable

When this signal is true (low), the write electronics are prepared for writing data and the read electronics are disabled. This signal turns on write current in the selected read/write head. Data is written under the control of the Composite Write Data and Side Select input lines. When the Write Enable line is false (high), all write electronics are disabled.

When a write protected diskette is installed in a drive, the write electronics are disabled, irrespective of the state of the Write Enable or Side Select lines.

#### Side Select, TM50-2

The Side Select interface line defines which side of a two-sided diskette is used for information transfer.

A false (high) level on this line selects the read/write head on side zero, the lower head, of the drive. A true (low) level on this line selects the read/write head on side one, the upper head, of the drive.

### Output Control Lines

#### Index/Sector

The index/sector signal is a composite of the index pulse and sector signals.

An index pulse is provided once every revolution, 200 milliseconds nominal, to indicate the beginning of a track to the controller. The leading edge of this signal must always be used to ensure timing accuracy. The index/sector line remains in the true (low) state for the duration of the index pulse, which is nominally four milliseconds.

The sector signal portion appears only when using hard sectored diskettes.

#### Track 0

When the drive is selected, the Track 0 interface signal, when true (low), indicates to the controller that the read/write head(s) are positioned at Track 0. This signal remains true (low) until the heads are moved from Track 0.

#### Write Protect

When the Write Protect line goes true (low), the diskette is write protected and the write electronics are disabled. It is recommended the controller not issue a Write command when the Write Protect signal is true (low).

When the Write Protect line is false (high), the write electronics are enabled.

#### Composite Read Data

This interface line transmits the readback data to the controller when the drive is selected. It provides a pulse for each flux transition detected from the diskette. The Composite Read Data output line goes true (low) for a duration of  $1 \pm 0.25$  microseconds for each flux change detected from the diskette.

The leading edge of the Composite Read Data output pulse represents the true position of the flux transitions on the diskette's surface.

## Typical Interface Characteristics

Lines between the controller and the drive have the following characteristics:

$$V_{\text{out True}} = + 0.4 \text{ volt maximum at } I_{\text{out}} = 48 \text{ milliamperes, maximum}$$

$$V_{\text{out False}} = +2.4 \text{ volts minimum open collector at } I_{\text{out}} = 250 \text{ microamperes, maximum}$$

Figure 3-1 contains the characteristics of the electrical interface. Figure 3-2 contains the control and data timing requirements.

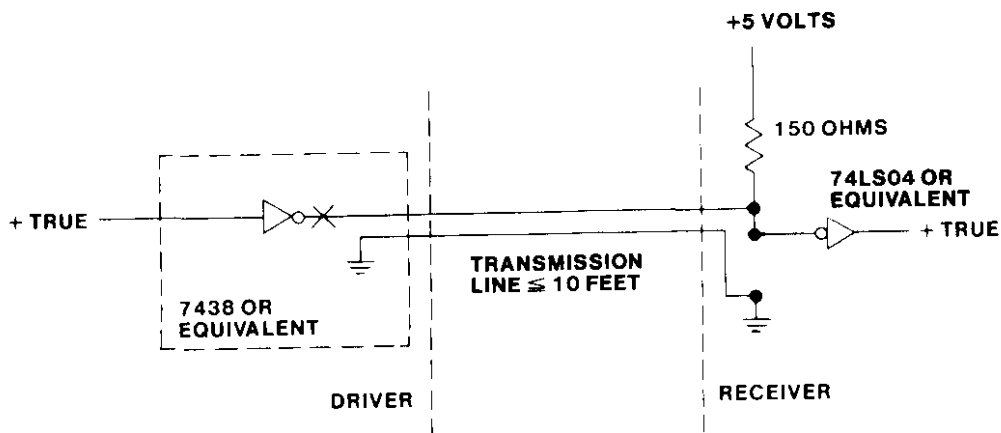

FIGURE 3-1

### ELECTRICAL INTERFACE CHARACTERISTICS

#### 3.5 D. C. POWER

D. C. power is supplied to this drive via a four-pin AMP connector, J7, connected to the rear of the drive. The mating connector, not supplied, is AMP Part Number 1-480424-0, using AMP contact Part Number 606191-1. Pin assignments are found in Table 3-2.

The chassis should be connected to earth ground to ensure proper operation.

TABLE 3-2 D. C. POWER CONNECTOR PIN ASSIGNMENTS	
Pin	Supply Voltage
1	+ 12 volts D. C.
2	12 volts return
3	5 volts return
4	+5 volts D. C.
Pin	Signal
Ground lug 3/16-inch quick disconnect	Chassis ground from controller

### 3.6 DRIVE ADDRESS AND OPTION PATCHING

The drive address and option patching is determined by the programmable shunt, located at U19 on the logic circuit board. The DS0 through DS3 jumpers determine the drive address. The MX jumper is used only in single drive systems. Drive address and option patching jumpers are located in Figure 3-3.

The program shunt is AMP Part Number 435704-7. The shunt positions can be cut using AMP's tool, Part Number 435705. The shunt is installed in a DIP socket. At the user's option, it can be removed and replaced by a DIP switch.

#### DS0 Through DS3 Jumpers

When daisy chaining two or more drives to a controller, the Drive Select (DS) jumpers patch the drive select control signal to enable the logic of the proper drive. Normally, all the shunt jumpers would be cut, except for the DS jumper that addresses each individual drive in the daisy chain. The terminator pack, 2F, located on the logic circuit board should be installed in the last drive of the daisy chain.

#### MX Jumper

The Multiplex (MX) jumper is used only in single drive systems when the user requires the drive logics to be enabled at all times. If the drive is not selected through the DS jumper, and the MX jumper is not cut, the drive logics are enabled but the front panel L. E. D. is not on. The MX jumper must be cut in a multiple drive system.



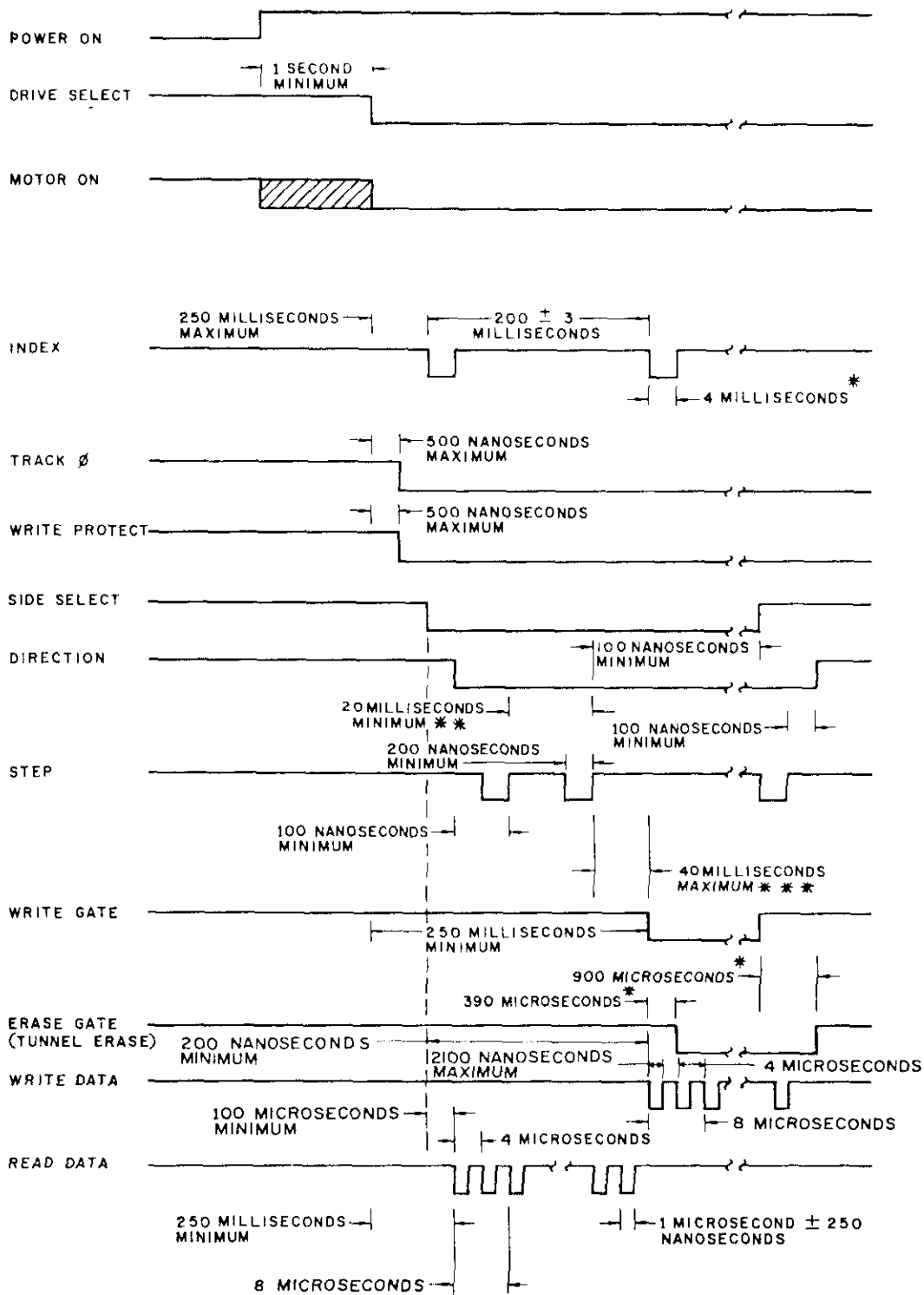

NOTES: \* FOR REFERENCE ONLY  
 \*\* 6 MILLISECONDS FOR FAST STEP MOTOR (OPTIONAL)  
 \*\*\* 21 MILLISECONDS FOR FAST STEP MOTOR (OPTIONAL)

FIGURE 3-2  
 CONTROL AND DATA TIMING REQUIREMENTS

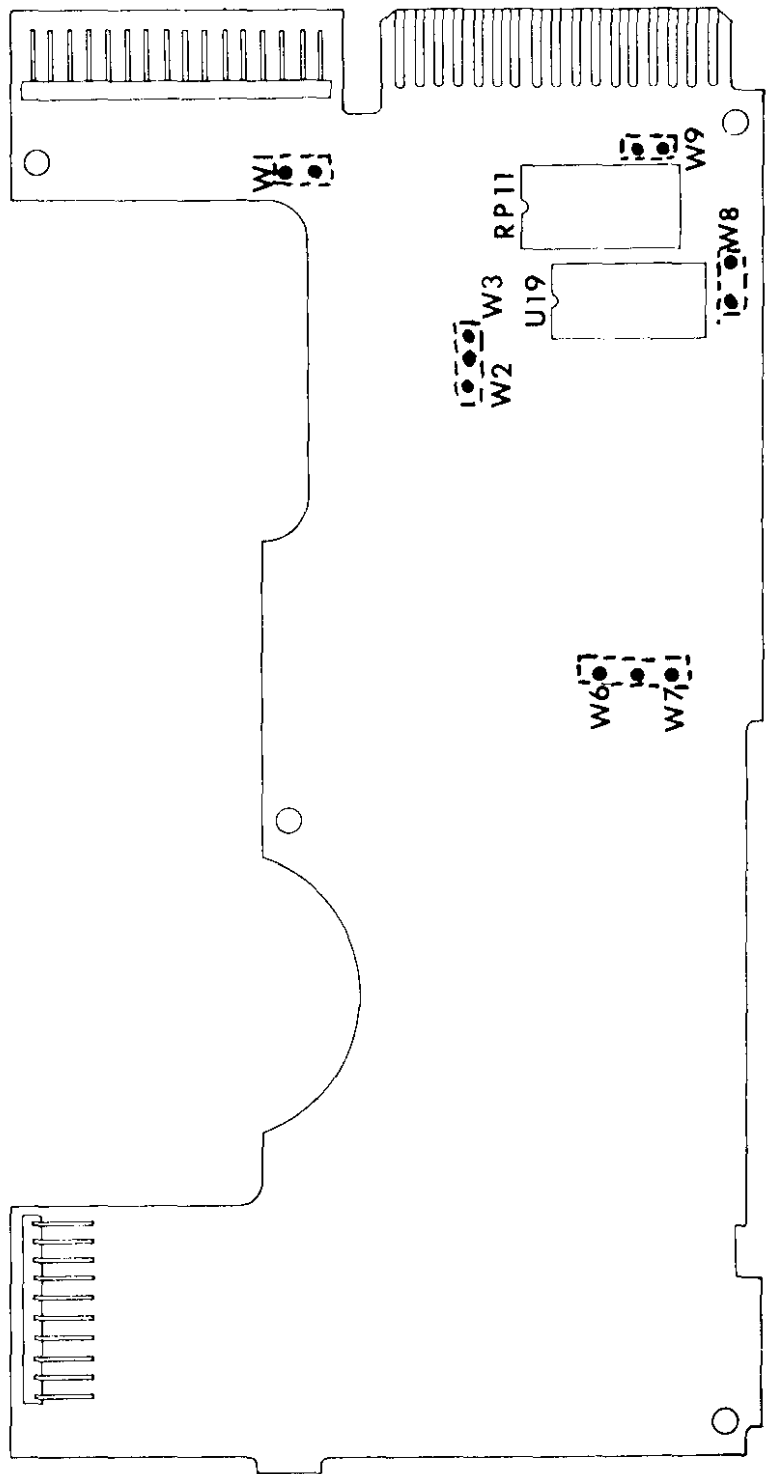
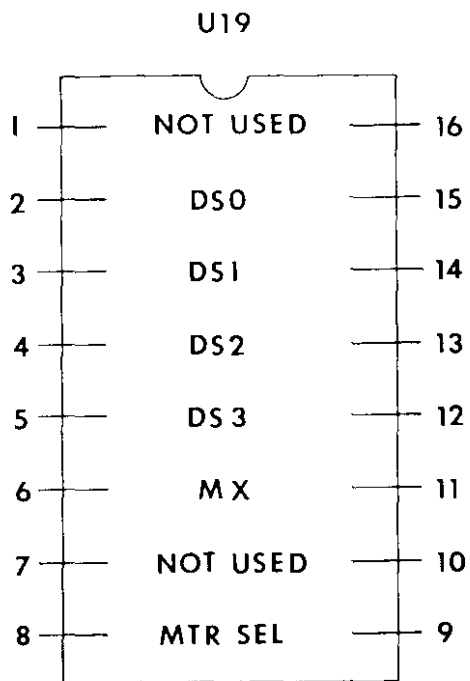

FIGURE 3-3

LOGIC BOARD WITH PROGRAMMABLE SHUNTS AND OPTION PATCHING LOCATIONS

## Motor Select Jumper

The Motor Select jumper, MTR SEL, should be connected when the spindle motor is to be turned on using Drive Select or Motor On Control lines.

### NOTE

The following jumpers are located on the read/write control board.

X = Connected  
- = Not Connected

## Write Protect (W1)

The standard write protect feature is W1 removed. Write protect control is inhibited with W1 installed.

<u>W1</u>	<u>Write Protect</u>
-	Write Protect control, in response to a write protected diskette, inhibits Write Gate, thus disallowing the flow of write data to the read/write heads.
X	Write Protect Control is inhibited.

## Head Type (W2, W3)

This option selects the type of head used.

<u>W2</u>	<u>W3</u>	<u>Head Type</u>
-	X	Tunnel erase.
X	-	Straddle erase (optional).

## W4 Through W8

W4 through W8 are not used.

## Side Select (W9)

For use in double-sided drives.

<u>W9</u>	<u>Side Select</u>
-	For use in single-sided drives, TM50-1.
X	For use in double-sided drives, TM50-2.

### NOTE

The following jumper is located on the motor control board.

## Motor On (W1)

The standard operation has a Motor On signal controlling the drive motor. The drive motor can be controlled by Drive Select when W1 is installed.

<u>W1</u>	<u>Motor Is Controlled By</u>
-	Motor On J8-16.
X	Motor On or Drive Selected.

## 3.7 DISKETTES

The TM50-1 and TM50-2 drives use an ANSI-compatible 5-1/4-inch diskette. Diskettes are available with a single index hole or with multiple (index and sector) holes.

Diskettes with a single hole are used when soft sector format is required. Multiple hole diskettes provide sector information through the use of an index sensor and electronics.

Figure 3-4 contains the diskette used with the drive. This recording media is a flexible diskette enclosed in a protective jacket. The protected diskette, free to rotate within the jacket, is continuously cleaned by its soft fabric lining during normal operation.

### Loading The Diskette

The drive is loaded by inserting the diskette, head aperture forward, into the front slot of the drive. Access to the diskette loading slot is obtained by opening the front latch.

The diskette should be carefully inserted until it is solidly against the back stop.

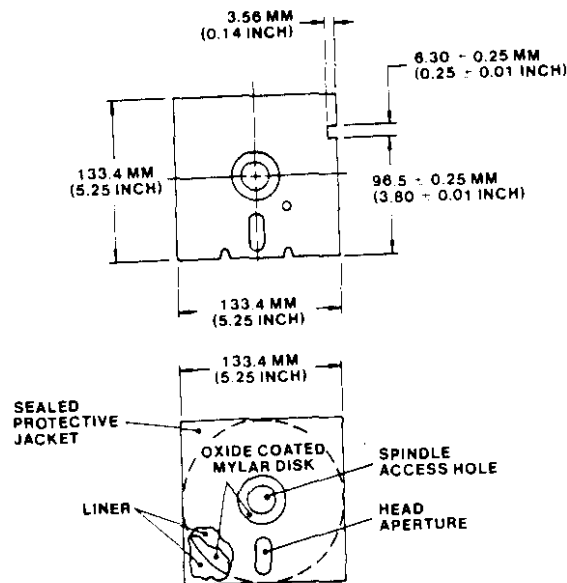

FIGURE 3-4

## CAUTION

Damage to the center of the diskette may result if the door is closed when the diskette is not properly inserted. This prevents reliable recovery of recorded data.

### Write Protect Tab

The drive is equipped with a write protect sensor assembly. This sensor operates in conjunction with a diskette that has a slot cut in the protective jacket.

When the slot is covered with an optically opaque, self-adhesive tab, the diskette is write protected. The tab must be removed to write on the diskette. Figure 3-5 contains information on how to install a tab to cover the slot.

### Diskette Handling and Storage

It is important the diskette be handled and stored correctly so the integrity of the recorded data is maintained. A damaged or contaminated diskette can impair or prevent recovery of data, and can result in damage to the read/write heads.

Figure 3-5 contains an illustration of the physical configuration of the diskette. The 5.125-inch diskette is oxide-coated, flexible mylar. It is enclosed in a 5-1/4-inch square protective jacket. In addition, openings for the drive hub and diskette index hole are provided.

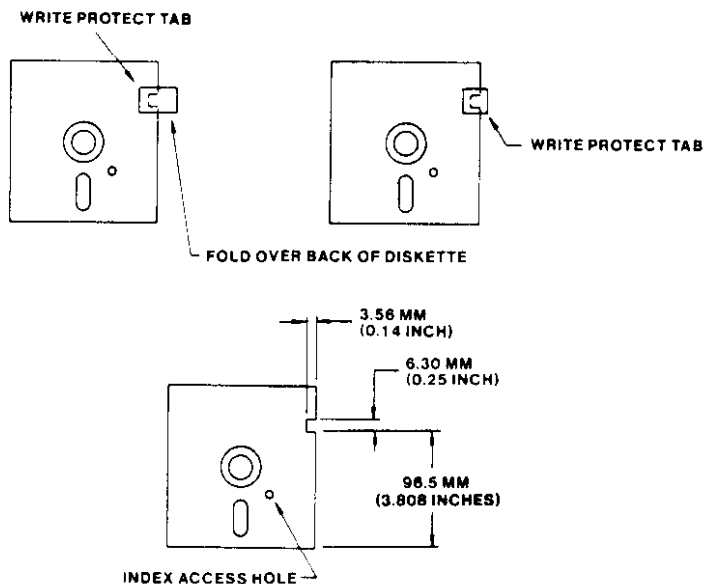
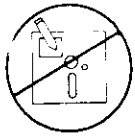

FIGURE 3-5

WRITE PROTECT TAB

Figure 3-6 provides some helpful hints on the care and handling of the drive and diskettes. In addition, to ensure trouble-free operation and to enhance the service life of the diskette, the following handling procedures should be observed.



DO NOT WRITE ON THE JACKET WITH PEN OR PENCIL. USE A FELT TIPPED PEN.

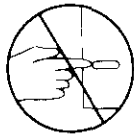

DO NOT TOUCH PRECISION SURFACE WITH YOUR FINGERS.

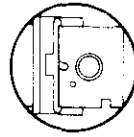

TO AVOID DAMAGE TO THE DISKETTE AND TO YOUR DRIVE, INSERT DISKETTE CAREFULLY UNTIL THE BACKSTOP IS ENCOUNTERED.

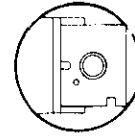

RETURN THE DISKETTE TO ITS JACKET WHEN NOT IN USE.

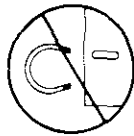

KEEP THE DISKETTE AWAY FROM MAGNETIC FIELDS.

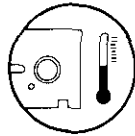

DISKETTES SHOULD BE STORED AT  
10°C to 52°C  
50°F to 125°F

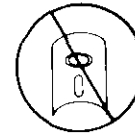

HANDLE WITH CARE; BENDING AND FOLDING MAY DAMAGE DISKETTE.

FIGURE 3-6

### DISKETTE CARE AND HANDLING

1. Return the diskette to the protective jacket when not in use.
2. Avoid exposing the diskette to any magnetizing force in excess of 50 oersted.

#### Note

The 50-oersted level magnetizing force is reached at a distance of approximately three inches from a typical source, e. g., motors, generators, or transformers.

3. To avoid warping, do not store the diskette in direct sunlight.
4. Do not use a lead pencil or a ballpoint pen to write on the label. Use a felt tipped pen, and mark lightly on the label.

## SECTION 4

### THEORY OF OPERATION

#### INTRODUCTION

This section contains a description on the theory of operation of the drive. The discussion begins with a general summary of magnetic data recording, followed by a description of each major function of the drive.

Circuit block diagrams and schematics are located in the appendices. They are useful to show the interconnections between the electronic circuits and the mechanical components.

#### 4.1 DATA RECORDING

Digital information is represented by a sequence of bits: either 0 or 1. Small areas of the medium in which such binary information is stored, for example the iron oxide coating of a magnetic disk, must be put in one state or the other to represent the data.

Recording of data on a magnetic medium is based on the principles of electromagnetics. When current flows in a coil of wire it produces a magnetic field. The field is confined in a core of magnetic material around which the wire is wound. A narrow slot, called the air gap, is placed in the core located closest to the media. It is the magnetic field in the vicinity of the air gap that magnetizes the magnetic medium (Figure 4-1). When the current is reversed, the polarity of magnetization is reversed.

Information can be recorded on the diskette by using a double-frequency code. The magnetization profiles in each bit cell for the number sequence shown for FM recording are shown in Figure 4-2.

When data is read, the same head that writes the data is used. The data stored is a digital bit representing a 0 or 1. In each bit cell, the first flux reversal represents a clock bit. A second reversal represents a stored bit 1. The absence of a second reversal represents a bit 0.

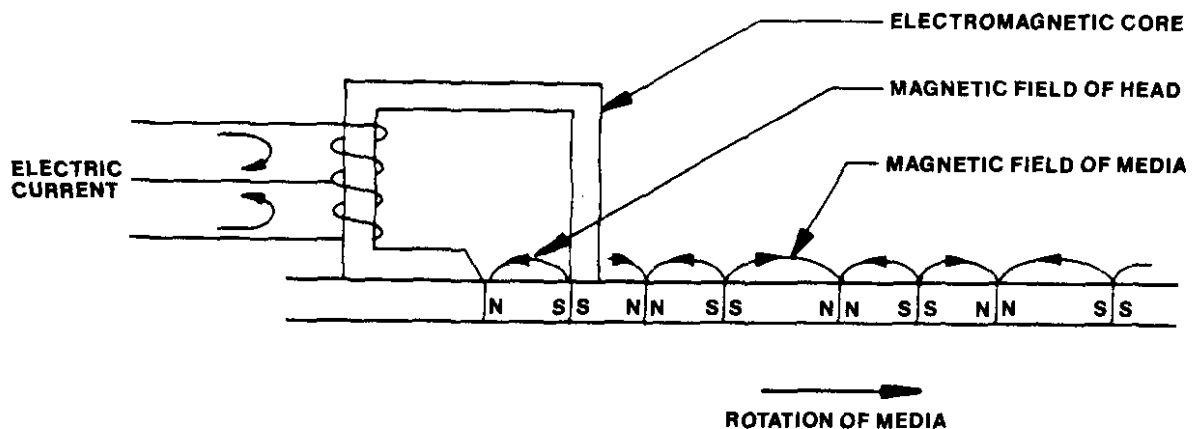

FIGURE 4-1

ELECTROMAGNETIC CORE

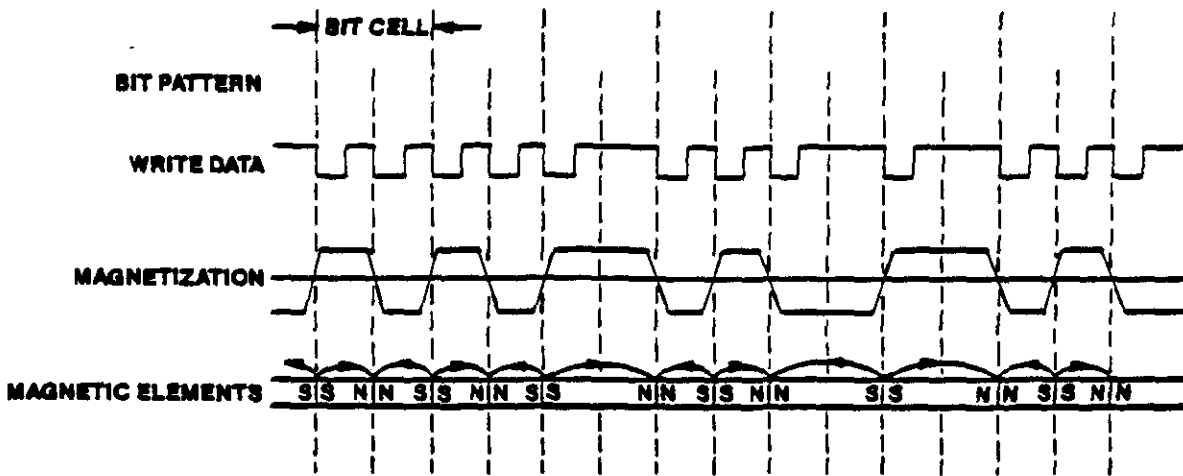

FIGURE 4-2

FM RECORDING MAGNETIZATION PROFILES

As the disk spins, the magnetic fields of the stored data pass successively under the head. The changing fields induce, in the head, an A. C. voltage signal which is then amplified and filtered, differentiated, and digitized (Figure 4-3).

The comparator and the digitizer circuitry generate a one microsecond Read Data pulse, corresponding to each peak of the Read signal. Then, the composite read data signal is sent to the user system via the Read Data interface line.

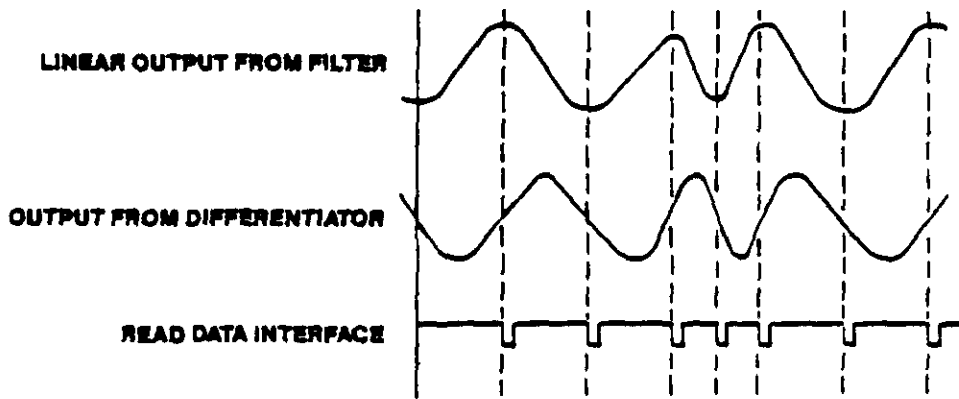

FIGURE 4-3

READ TIMING DIAGRAM



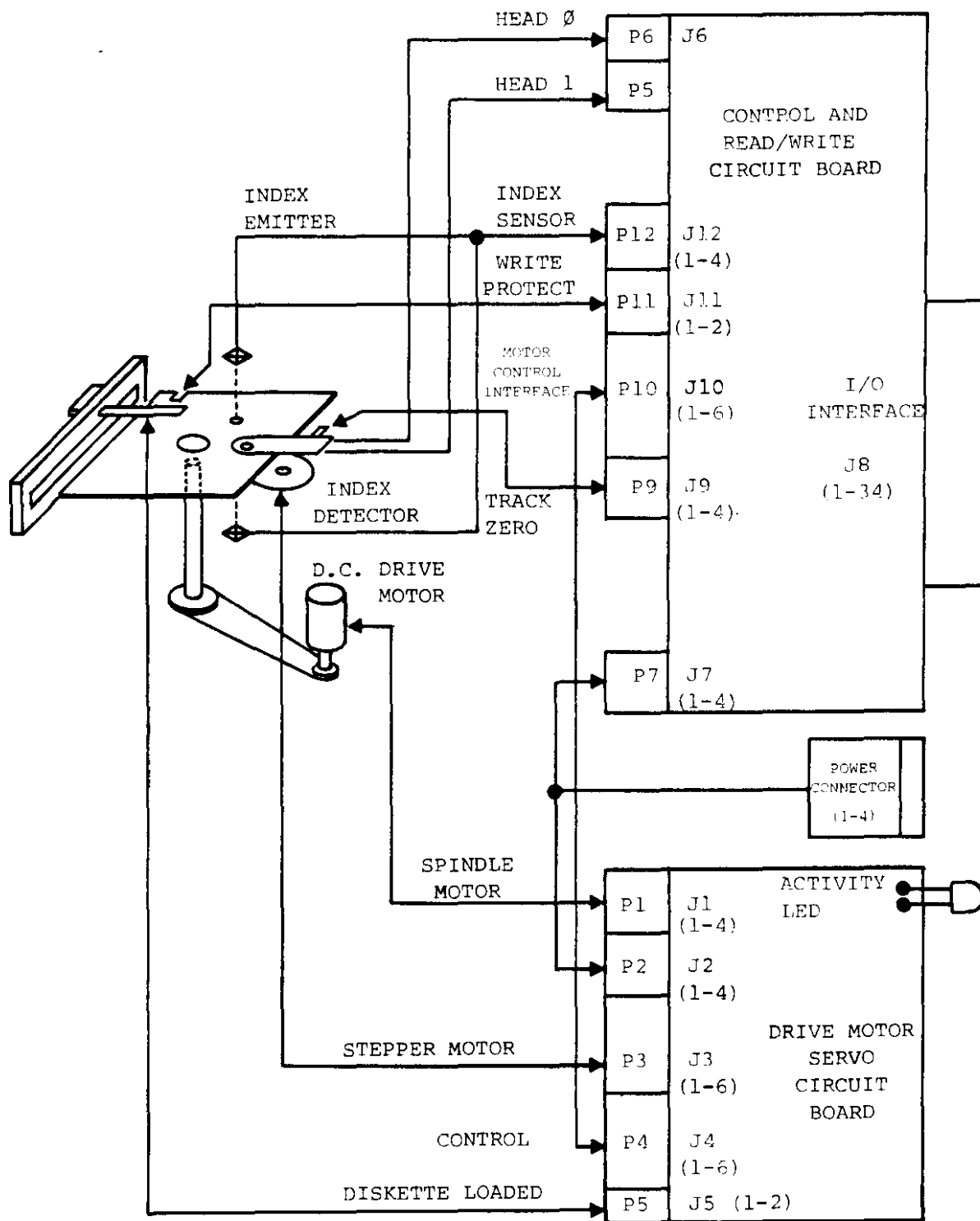

FIGURE 4-4

INTERCONNECT BLOCK DIAGRAM

## 4.2 COMPONENTS OF THE DRIVE

The drive contains the electrical and mechanical components required to perform four major functions:

1. Generate and interpret control signals.
2. Position the read/write head(s) to the desired track.
3. Write and read data.
4. Control the spindle.

The electrical and mechanical components of the drive are connected together via multiple pin connectors. This allows the individual assemblies to be removed (Figure 4-4).

## 4.3 GENERATE AND INTERPRET CONTROL SIGNALS

The components of the drive required to generate and interpret the control signal are:

1. Index Sensor
2. Write Protect Switch
3. Track 0 Sensor
4. Drive Select

### Index Sensor

The Index signal is derived from an infrared L. E. D. and photo-transistor detector. When the index/sector hole in the diskette passes through the index sensor, the light from the L. E. D. is allowed to turn on the index detector, producing a positive pulse on J12, Pin 4 (Figure 4-5).

This signal is shaped by an input buffer, U9, and supplied to inverter IC U17. Then it is gated with Drive Select for an output control signal at the interface J8, Pin 8.

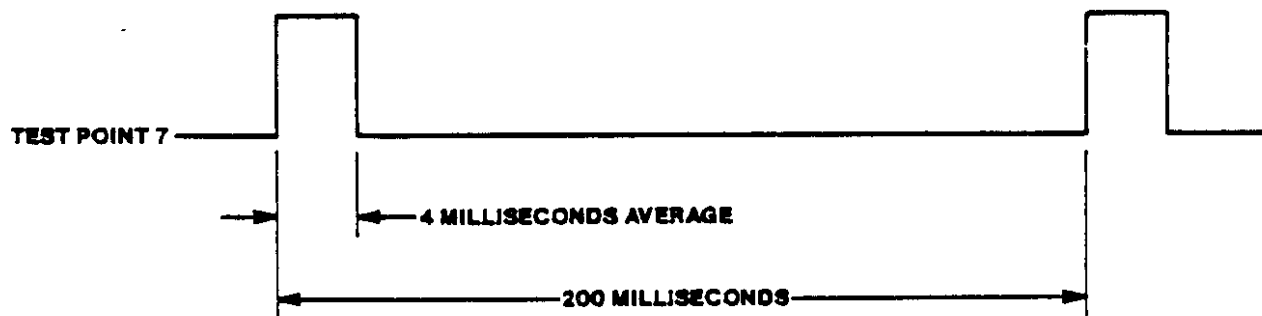

FIGURE 4-5

SOFT SECTORED INDEX PULSE

Write Protect Switch

The Write Protect signal is derived from a mechanical switch integrated into the drive, the switch is deactivated, causing a high signal on J11, Pin 5. Then, it is buffered and inverted to disable the Write Enable signal. It is also gated with drive select, producing an output signal on the interface.

Track 0 Sensor

The Track 0 sensor signal is derived from an infrared L. E. D. and phototransistor internal to the drive. As the head carriage moves back toward Track 0, the sensor is activated between Tracks 0 and 2.

This low active signal comes in via J9, Pin 4. It is inverted by IC U9. The combination of the Track 0 sensor being activated and the proper stepper motor phase (Phase 0) produces a low output at IC U8, Pin 6 (Test Point 10). This signal is buffered through IC U17, Pins 9 and 8, to be gated with drive select at IC U18, Pins 9 and 10, to give a Track 0 output to Pin 26 of the interface. After IC U17, Pin 8, this signal is gated with direction (IC U7, Pin 12) at IC U6, Pins 12 and 13.

IC U6, Pin 11, when true low inhibits stepping to Track 0 minus 1.

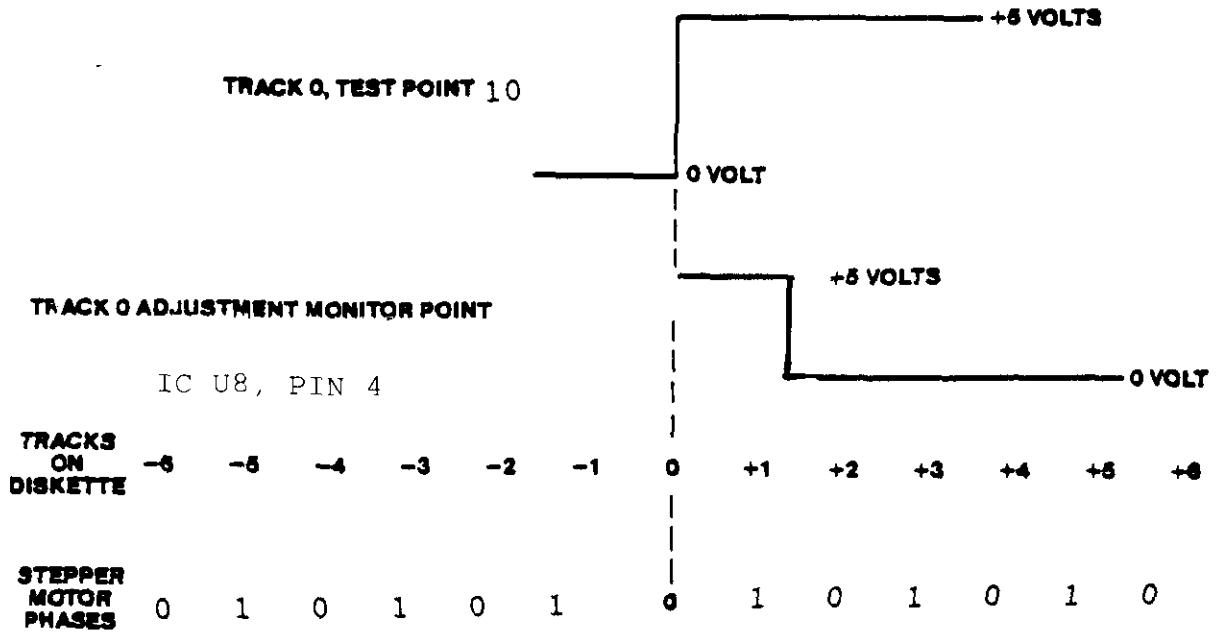

FIGURE 4-6  
TRACK 0 TIMING

Drive Select

The Drive Select signal is derived from the host controller through the interface connector.

R39 holds the output of the appropriate select line high until the line is driven low. The signal is buffered through IC U17, which enables the drive's electronics.

The front panel L. E. D., physically located on the drive motor's, servo circuit board, is driven by the select logic through IC U17, Pins 5 and 6, and IC U7, Pins 11 and 10, to provide the NSEL signal at J10, Pin 5, to the servo circuit board on J4, Pin 5. This signal is buffered and inverted to activate the front panel L. E. D.

If the drive is not selected through the select jumpers and the MX jumper is not cut, U19, Pins 6 to 11, the drive electronics are active but the front panel L. E. D. is not on.

#### 4.4 READ/WRITE HEAD POSITIONER

The components of the drive required to position the read/write head(s) at the desired track are:

1. Step and direction circuits
2. Stepper motor control circuits
3. Stepper motor

##### Step and Direction

The Step and Direction signals are derived from the host controller via interface connector J8, Pin 20, and J8, Pin 18, respectively.

The direction line is buffered and inverted on the control and read/write circuit board and sent to the motor control circuit board via J10, Pin 1. On the motor control circuit board, it is used as the D input of IC U6, Pin 12, the direction flip-flop.

The step pulses are buffered by IC U17, Pins 1 and 2, and gated with Drive Select at IC U8, Pins 9 and 10. IC U8, Pin 8, is inverted by IC U7, Pins 1 and 2. Test Point 11 can be used to monitor the step input, which is output at J10, Pin 3, to the motor control circuit board.

On the motor control circuit board, the step pulses are used to clock the direction flip flop IC U6 at Pin 11 and the step one shot flip flop (time is two microseconds) at IC U8, Pin 10.

Generation of controlling signals for correct stepping phases is accomplished via IC U7. The direction flip flop controls the up or down counting of the step pulses (two pulses per track) used by IC U7.

IC U8, Pin 12, when clocked by a step pulse will clock IC U7 at Pin 14, thus Pin 3 of IC U7 will trigger a 10-millisecond one shot at IC U8, Pin 2, which retriggers the two microsecond step flip flop IC U8, Pin 9. IC U7 is clocked again to complete a single phase rotation of the stepper motor through logic driver IC's U1 and U2.

##### NOTES

THE TIMES IN THE ABOVE DESCRIPTION ARE FOR THE 20-MILLISECOND STEPPER MOTOR. FOR ADDITIONAL INFORMATION, SEE TABLE 1, SHEET 1 OF 3, MOTOR CONTROL SCHEMATICS FOR COMPONENT VALUES AND CHANGES FOR SIX-MILLISECOND STEPPER MOTORS.

PHASE 0 OF THE STEPPER MOTOR IS ACTIVE ON ALL EVEN TRACKS: 0, 2, 4, 6.

## Stepper Motor Control

The stepper motor control circuits generate the two phases of the step sequence based on information from the step and direction inputs. These two phases are fed to the stepper motor drivers, which produce the current through the motor's coils.

## Stepper Motor

The stepper motor is a single phase motor, which rotates 3.6 degrees for each phase. The capstan and split band translates this rotation to a one track linear movement of the head carriage assembly.

### 4.5 READ/WRITE DATA

The components of the drive required to read and write data are:

1. Read/Write Head Assembly
2. Side Select circuits
3. Write/Erase circuits
4. Read Data circuits

## Read/Write Head Assembly

The read/write head(s) are glass bonded, ferrite cores mounted in a ceramic structure. The lower head structure is mounted in a fixed position to a plastic carriage. The upper head is mounted to a gimbaled flexure to conform to the diskette.

The head carriage assembly is attached to the chassis on guide rails. It is positioned by a split band attached to the stepper motor.

## Side Select Circuits

The Side Select signal is derived from the host controller via the interface connector J8, Pin 32. This signal is buffered. If the signal is high at the interface, Side 0 is selected by applying a voltage potential on the center tap of Head 0, and allows current to flow in the coils of Head 0. If the signal at the interface is low, Side 1 is selected by applying a voltage potential on the center tap of Head 1, allowing current to flow in the coils of Head 1.

In the read mode, a potential of +5 volts D. C. is applied to the selected head diode matrix. The write mode increases the voltage applied to the selected head diode matrix to +12 volts D. C. from the beginning of Write Enable until the end of Internal Write Busy.

### Write/Erase Circuits

The write electronics consist of a write current source, a write waveform generator, an erase current source, the trim erase control logic, and the side select logic (Figure 4-7).

The signals required to control the data electronics provided by the host controller are:

1. Drive Select
2. Write Enable
3. Write Data
4. Side Select

The winding on the head is center tapped. During a write operation, current from the write current source flows in alternate halves of the winding, under control of the write waveform generator.

When the drive is selected and write protect is false, N Write Enable initiates the write logic. Seven events that occur are (Figures 4-7 and 4-8):

1. The pre-erase delay one shot is started, 390 microseconds.
2. The post-erase delay one shot is started, 900 microseconds.
3. The post-erase delay one shot outputs a signal: N Internal Write Busy. It is used to disable the Read Data output circuit, NWRT to increase the read/write diode matrix voltage from 5 volts D. C. to 12 volts D. C. via the side select logic during a write operation.
4. The write current source is enabled via U4.
5. The write waveform generator has its preset and clear inputs set to +5 volts D. C. instead of ground (optional).
6. Input diodes to the read amplifier are reverse biased by N Write to protect the read amplifier during the write operation.
7. The write data input is inverted and used to clock the waveform generator which selects a write driver, thus providing a ground to forward bias a diode, allowing current to flow through the coil.

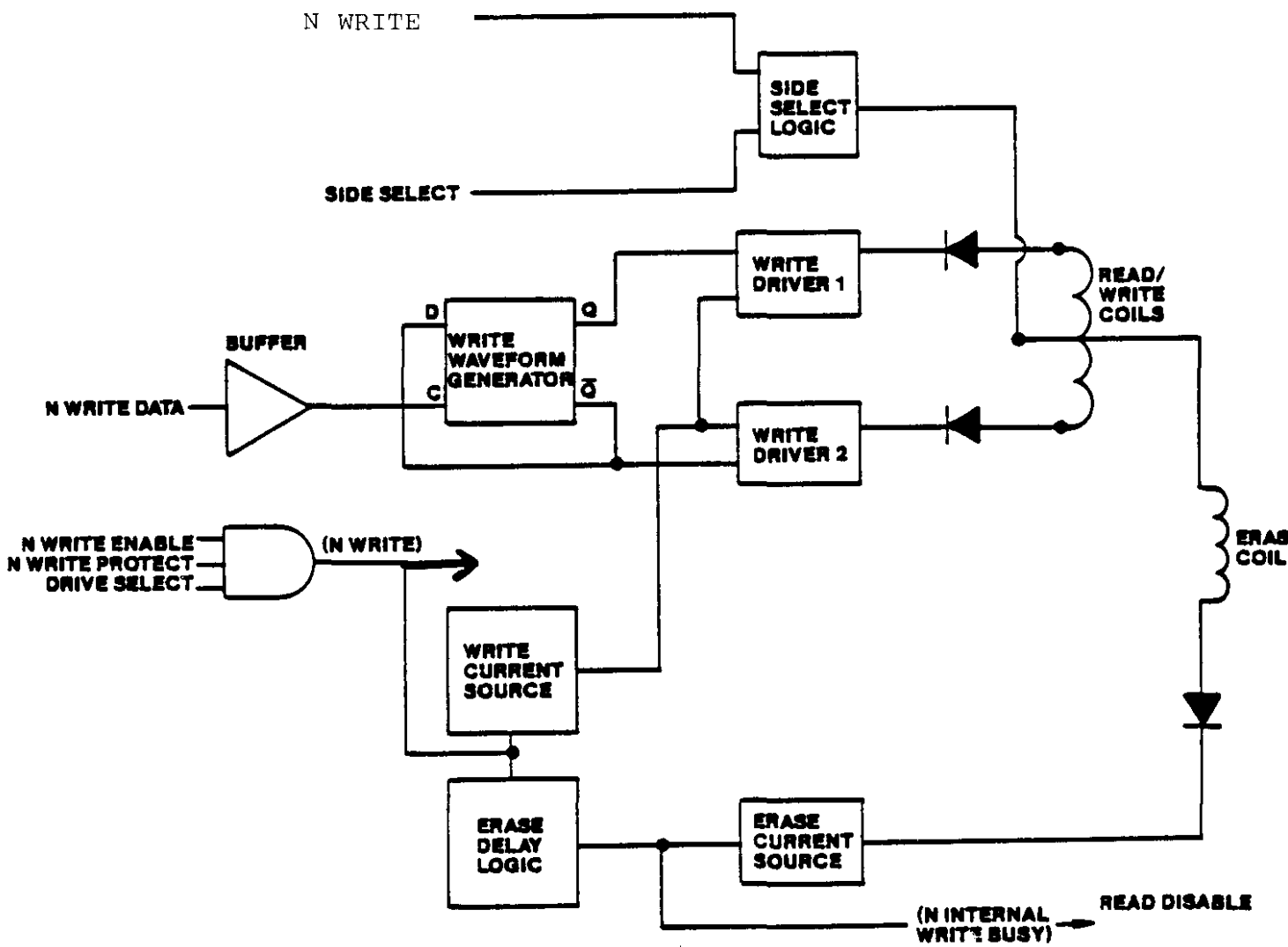
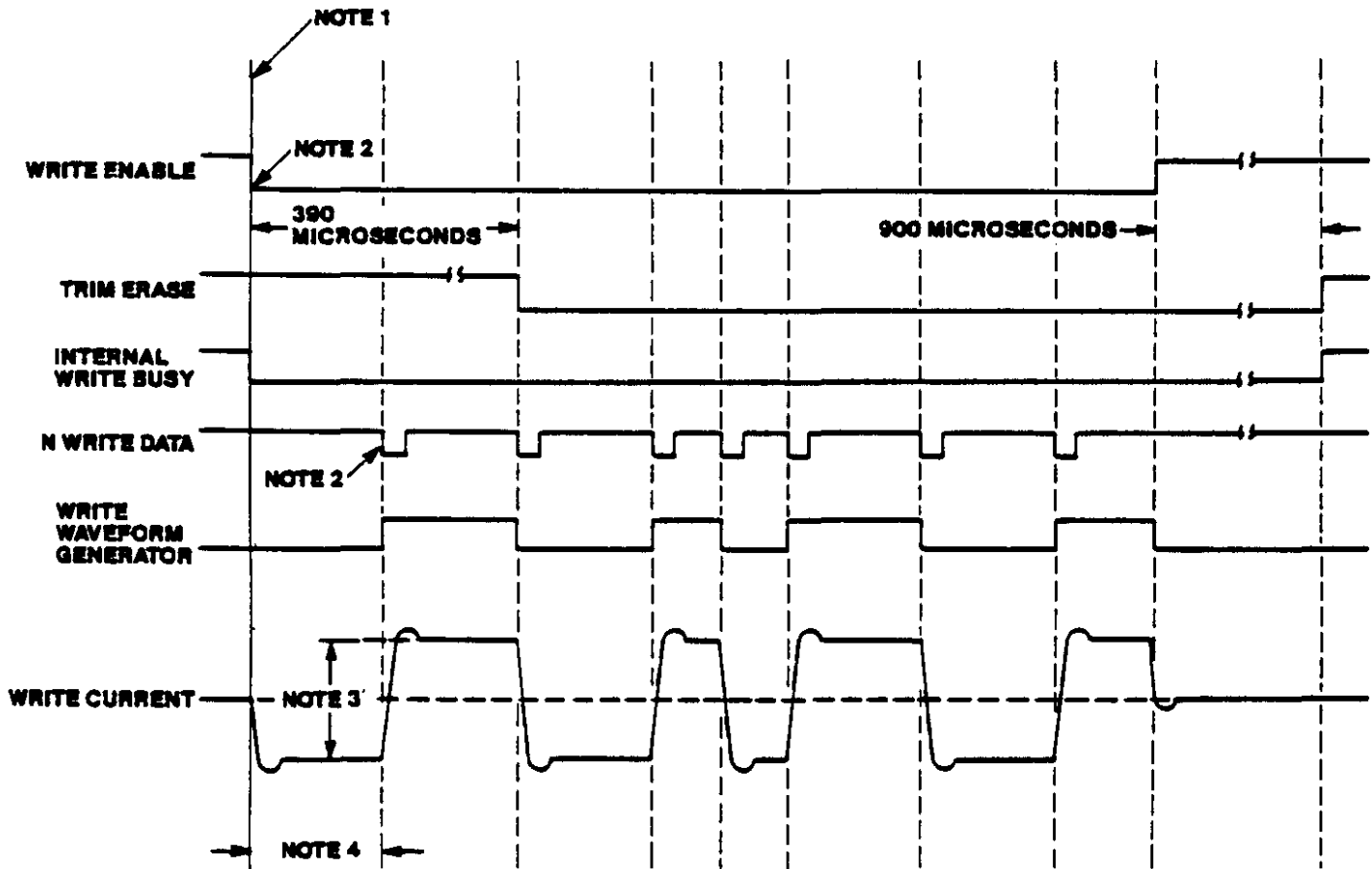

FIGURE 4-7

WRITE DATA CIRCUIT BLOCK DIAGRAM





- NOTES:**
1.  $t = 0 = 250$  MILLISECONDS AFTER DRIVE MOTOR STARTS OR 20 MILLISECONDS AFTER LAST STEP PULSE, WHICHEVER IS THE LATEST TIME.
  2. UNSYNCHRONIZED
  3. 8.5 MILLIAMPERES PEAK TO PEAK .
  4. 4 MICROSECONDS MINIMUM, 8 MICROSECONDS MAXIMUM .

FIGURE 4-8  
WRITE OPERATION TIMING DIAGRAM

When there is a pre-erase delay 390-microsecond time out, the erase current source is turned on.

The clocking of the waveform generator during write operation provides a trigger to the post-erase delay one shot, and does not allow it to time out until all data is written.

N Internal Write Busy is active until the end of the post-erase delay, and keeps +12 volts D. C. on the read/write diode matrix during the erase time.

The duration of a write operation is from the true going edge of write Enable to the false going edge of Trim Erase. This is indicated by the Internal Write Busy waveform (Figure 4-8).

### Read Data Circuits

The read electronics consist of:

1. Read Only and Side Select circuits
2. Read Amplifier and Linear Phase Filter
3. Differentiator
4. Comparator, Time Domain Filter, and Digitizer

The Read Only circuits are used to isolate the read amplifier from the voltage excursion across the head during a write operation. The side select is used to enable one of the read/write head(s).

The drive must be selected by the user's system before reading can begin. In addition to the requirements established in this section, a 100 microsecond delay must exist from the trailing edge of the Trim Erase signal to allow the read amplifier to settle after the transient caused by the Read Only circuit returning to the Read mode.

The output signal from the read/write head is amplified by a read amplifier, and filtered by a linear phase filter to remove noise. The linear output from the filter is passed to the differentiator, which generates a waveform whose zero crossovers correspond to the peaks of the Read signal. Then, this signal is fed to the comparator, time domain filter, and digitizer circuitry (Figure 4-9).

### 4.6 SPINDLE CONTROL

The components of the drive required to control the spindle are:

1. Spindle Motor and Spindle Assembly
2. Spindle Motor Enable circuit
3. Spindle Motor Control circuit
4. Diskette Enable Switch

## Spindle Motor and Spindle Assembly

The Spindle Assembly is driven by a belt attached between two pulleys. The drive motor pulley is turned by a D. C. motor with a built in integral tachometer. The spindle pulley connects to a hub that rotates a clamped diskette.

## Spindle Motor Enable Circuit

The Motor On signal is derived from the host controller to the interface connector via J8, Pin 16. This signal is buffered and supplied to the servo circuit board, which uses it to enable the motor current circuit of the spindle motor control via J10, Pin 6.

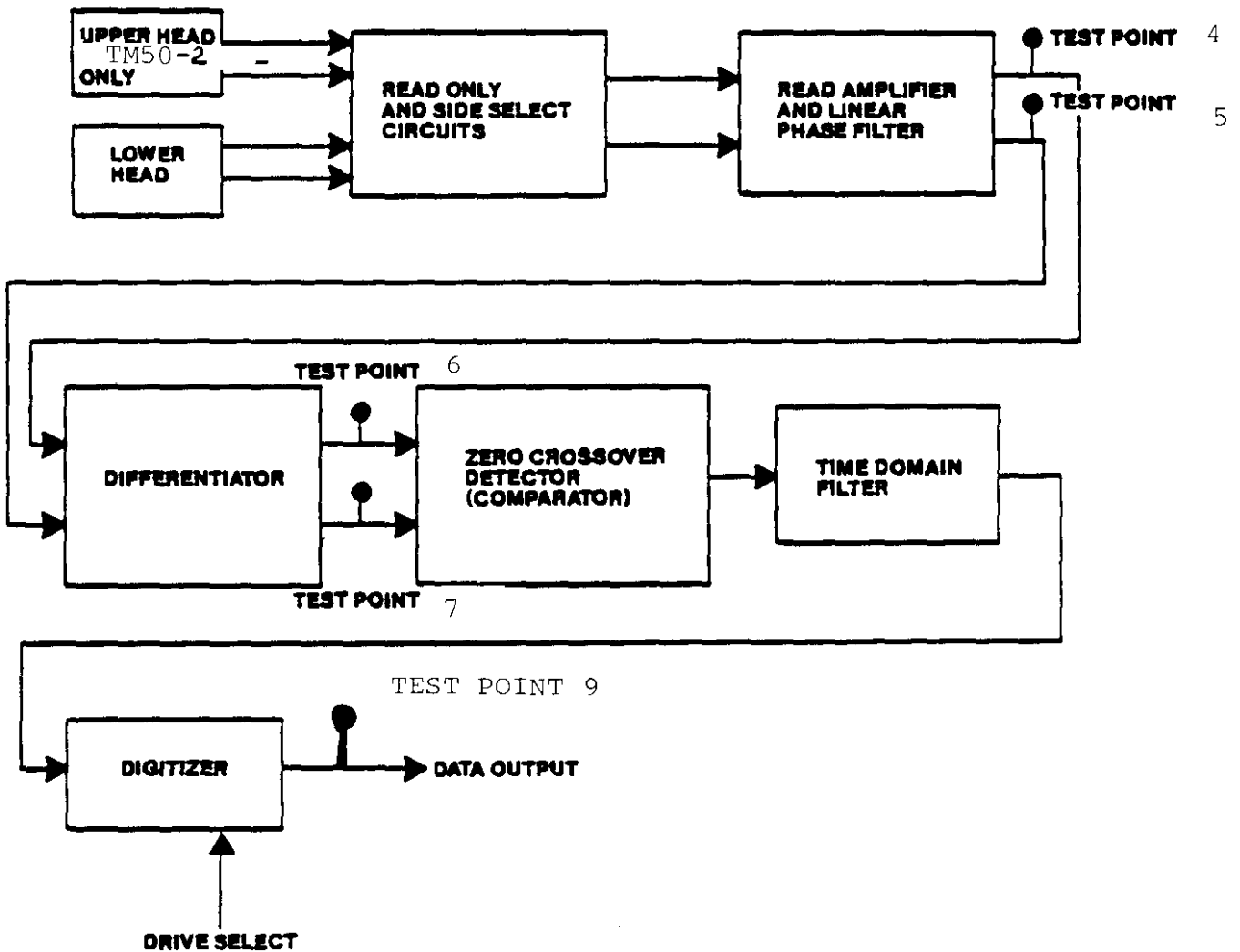

FIGURE 4-9

READ CIRCUIT BLOCK DIAGRAM

## Spindle Motor Control Circuit

The Spindle Motor Enable signal is input via J4, Pin 6, of the motor control circuit board to gate the spindle motor current (Figure 4-10). This current is controlled by an integrated regulator circuit when the spindle motor is enabled. The potentiator provides an adjustable D. C. voltage reference to the regulator circuit for spindle speed adjustment. The tachometer signal provides feedback from the motor via Pins 3 and 4 of J1 of the motor control circuit board to maintain a constant speed of 300 RPM. This signal is 12 volts A. C.

## Diskette Enabled Switch (Door Lever)

With power applied to the drive unit and the motor enable false, inserting a diskette into the drive and closing the door lever turns on the motor for five seconds. This feature ensures the proper clamping of the diskette to the spindle hub and the centering cone.

Motor control can be accomplished by drive select with W1 installed.

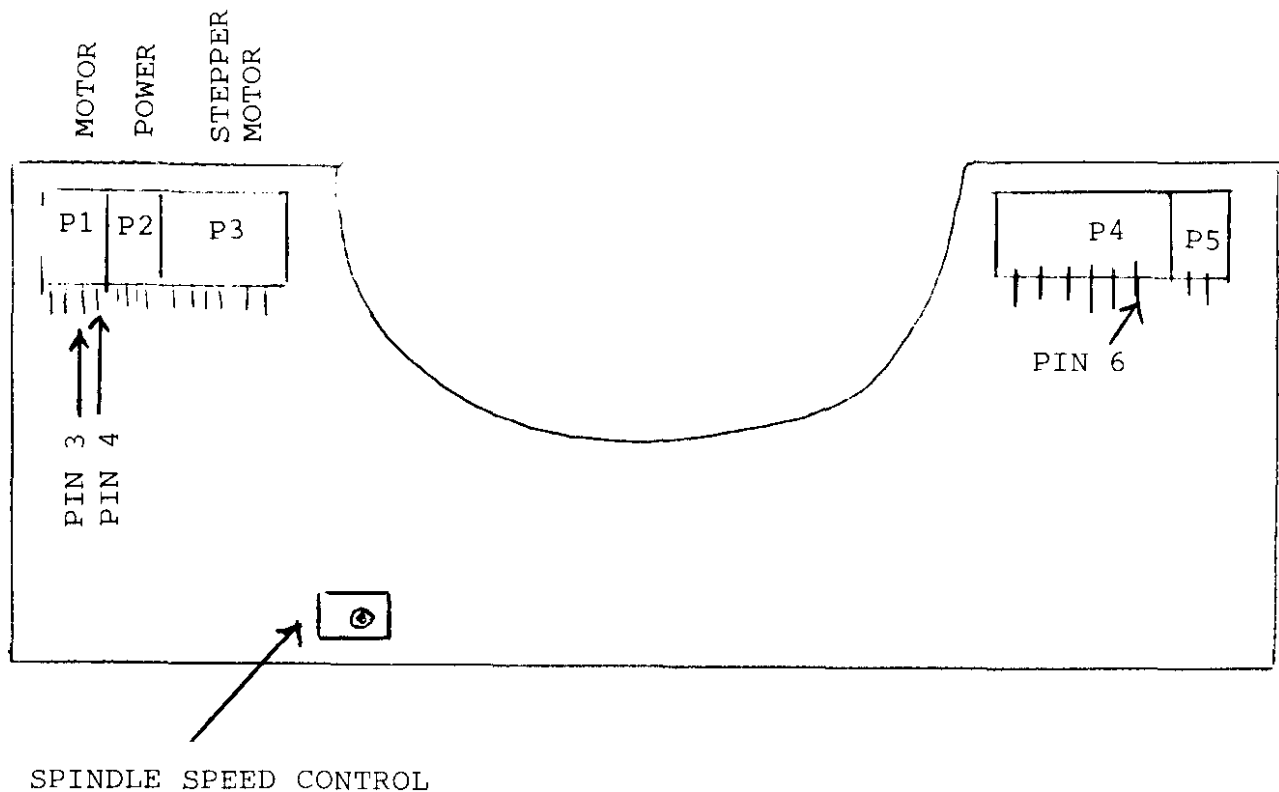

FIGURE 4-10

SERVO CIRCUIT BOARD

## SECTION 5

### MAINTENANCE CHECKS AND ADJUSTMENTS

#### INTRODUCTION

This section is for the use of the OEM Repair and Service Departments. It contains the maintenance checks and adjustments used during the normal life of the drive. The purpose of this section is to outline the steps necessary to verify the operation of the drive during troubleshooting, or after replacing a part or assembly.

If a fault is suspected with a drive, following the checks and adjustments in the order presented will help to isolate the problem area. However, if a specific check and adjustment is required, the preceding checks do not necessarily need to be performed.

The values and tolerances stated in the checks and adjustments are typical values for working drives. If the values measured are within tolerances or close to the limits, the suspected fault is normally caused by some other problem. Completing other checks and adjustments may disclose the actual problem.

Refer to the schematics in the appendices and the theory of operation in Section 4 for circuit descriptions. Test point location is illustrated in Figure 5-1.

#### 5.1 VISUAL INSPECTION

Before applying power to the drive, or doing any checks or adjustments, visually inspect the drive:

1. Check for loose or missing hardware.
2. Ensure the front latch opens and closes. The head arm raises when the door is opened.
3. Ensure the front panel is secure.
4. Manually rotate the drive hub. It should rotate freely.
5. Ensure the circuit boards are secure.
6. Ensure the connectors are firmly seated, and installed correctly.
7. Check for damaged or missing components on the circuit boards.
8. Ensure that a diskette can be inserted and removed easily.

## TM50 TEST POINTS

- |   |   |
|---|---|
| <ol style="list-style-type: none"> <li>1. +12 volts D. C.</li> <li>2. Write Protect Switch</li> <li>3. Motor On (From Interface)</li> <li>4. Read (A. C.)</li> <li>5. Read (A. C.)</li> <li>6. Read (Differential)</li> <li>7. Read (Differential)</li> </ol> | <ol style="list-style-type: none"> <li>8. Ground</li> <li>9. Read Data To Interface</li> <li>10. Track Zero</li> <li>11. Step</li> <li>12. Index</li> <li>13. Select</li> <li>14. Ground</li> </ol> |
|---|---|

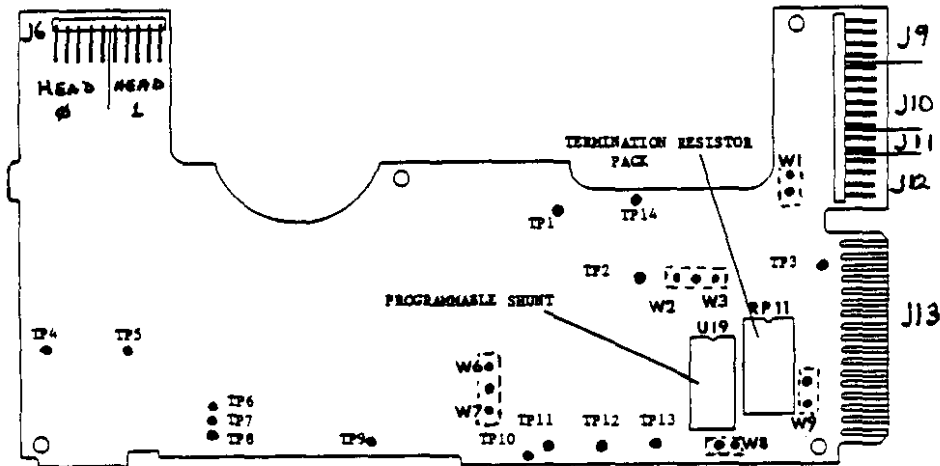

FIGURE 5-1

LOGIC CIRCUIT BOARD WITH TEST POINTS

### 5.2 EQUIPMENT REQUIRED

The following equipment is required for checks and adjustments.

1. A dual-channel, wideband oscilloscope, Hewlett Packard Model 1740A or equivalent.
2. An exerciser, AVA Model 103C or equivalent, or a software routine capable of stepping the drive to any track, selecting the upper or lower head, and writing a 1F, all zeros in FM, or 2F, all ones in FM, pattern.

3. A power supply.
4. A certified alignment diskette, Dysan Model 224/2A or equivalent.
5. A certified output diskette, write protected, Dysan Model 104/2D with tab or equivalent.
6. A certified output diskette, nonwrite protected, Dysan Model 104/2D or equivalent.
7. Associated power and interface cables.
8. A number 1 Phillips screwdriver.
9. Jeweler Screwdriver (speed adjust)
10. Spring inserter/remover
11. A flat blade screwdriver 3/16-inch tip.

Test equipment must be in calibration. This may be verified by observing the calibration due date on the calibration sticker affixed to the equipment.

### 5.3 POWER/DRIVE SELECT CHECK

The drive select check verifies the activity L. E. D. can be illuminated, and power is supplied to the drive. If the check fails, measure the power supply voltages to ensure they are correct.

1. Turn off power to the drive.
2. Connect the interface cable that goes from the exerciser to the drive.
3. Apply power to the drive.
4. Verify power supply voltages are within tolerances.
5. Ensure a drive select jumper is in place.
6. Select the drive.
7. Verify the front panel L. E. D. is illuminated.
8. Deselect the drive.
9. Ensure the front panel L. E. D. extinguishes.

#### 5.4 WRITE PROTECT SWITCH CHECK AND ADJUSTMENT

The write protect switch check and adjustment establishes the correct operation of the write protect switch, i. e. the write electronics are disabled when a write protected diskette is used.

##### Write Protect Switch Check

1. Connect the drive to an exerciser or computer with a direct monitor of the write protect output (J8, Pin 28) or, with no power to the drive, disconnect Plug 11, and check the continuity with an ohmmeter.
2. With a nonwrite protected diskette inserted, verify there is continuity between the two wires of Plug 11 or there is a nonwrite protected output to the exerciser, i. e., a high at J8, Pin 28.
3. With a write protected diskette inserted, verify there is no continuity between the two wires of Plug 11 or that there is a write protect true output to the controller or exerciser, i. e., a low at J8, Pin 28.

##### NOTE

A DEFECTIVE CIRCUIT BOARD CAN BE RESPONSIBLE FOR A WRITE PROTECT PROBLEM. TEST POINT 2 SHOULD BE LOW FOR A WRITE PROTECTED DISKETTE, HIGH FOR A NONWRITE PROTECTED DISKETTE.

##### Write Protect Switch Adjustment

1. Loosen the screws holding it to the bracket on the side nearest to the front of the drive (Figure 5-2).
2. Move the switch up or down, as required, and recheck it.

#### 5.5 DRIVE MOTOR SPEED CHECK AND ADJUSTMENT

The long-term drive motor's speed adjustment ensures the speed is within the specified tolerance. The motor speed tolerance is 300 RPM + 1.5 percent.

##### Drive Motor Check

1. Verify power: +12 volts D. C. + .6 volt  
+5 volts D. C. + .25 volt
2. Apply power to the drive.



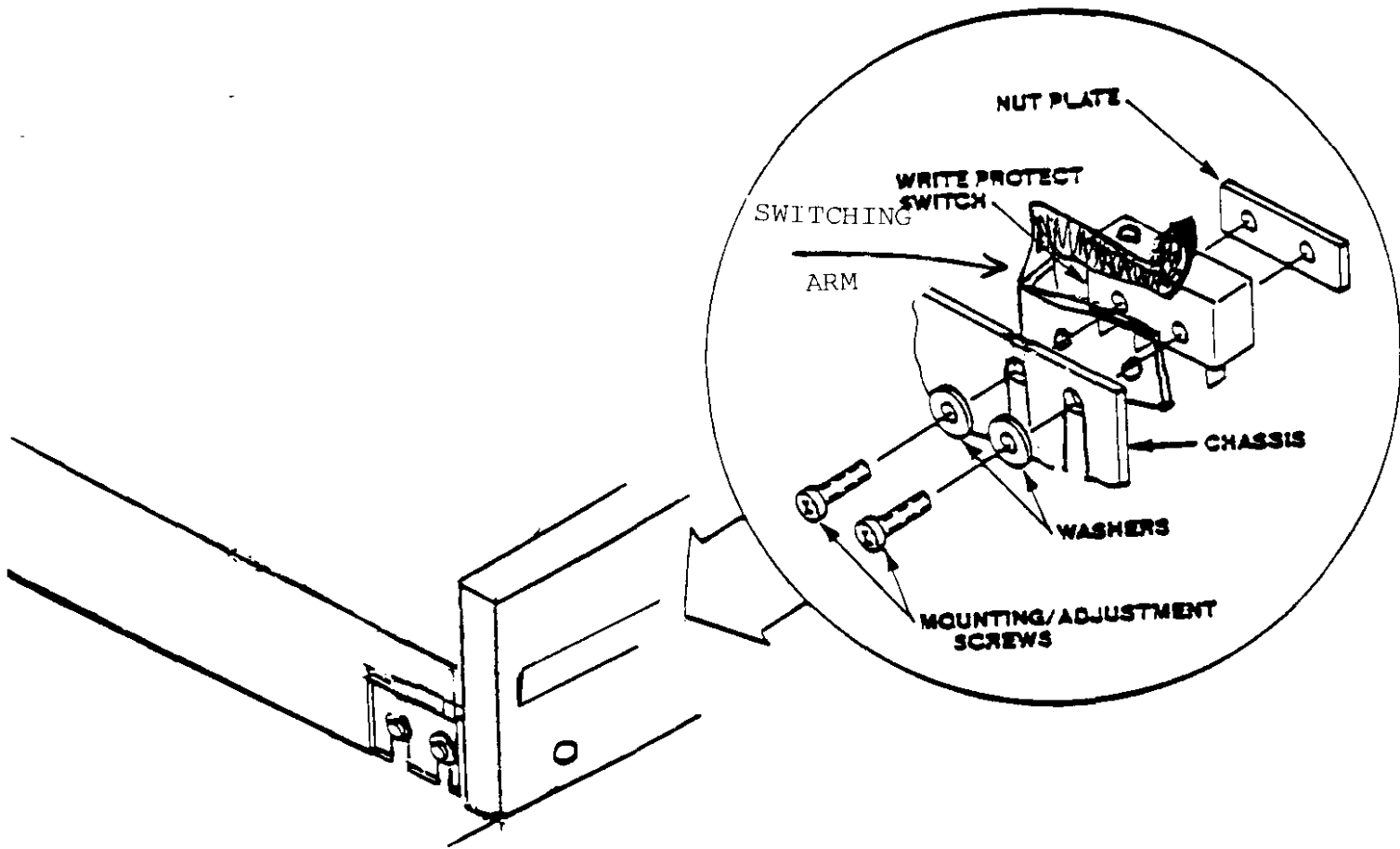

FIGURE 5-2

WRITE PROTECT SWITCH ADJUSTMENT

3. Activate the drive motor.
4. Insert a work diskette.
5. Observe the speed disk on the spindle pulley under ambient fluorescent lighting.
6. Verify the 60 Hertz outer ring is stationary.

Drive Motor Adjustment

1. Adjust R15, located on the Servo circuit board, until the speed disk is stationary (Figures 5-3 and 5-4).

## 5.6 RADIAL TRACK ALIGNMENT CHECK AND ADJUSTMENT

The Radial Track alignment procedure locates the read/write head at the proper radial distance on the hub center line, ensuring the track location is accurate (Figure 5-5). Adjustment is necessary only after servicing or if diskette interchange problems are suspected.

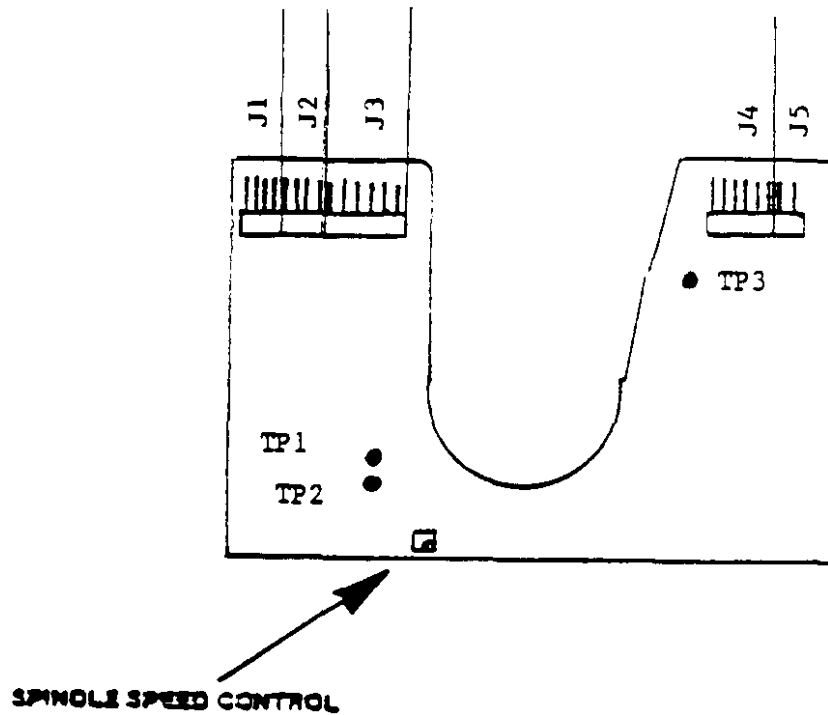

FIGURE 5-3

LOCATION OF R15 SPEED CONTROL POTENTIOMETER

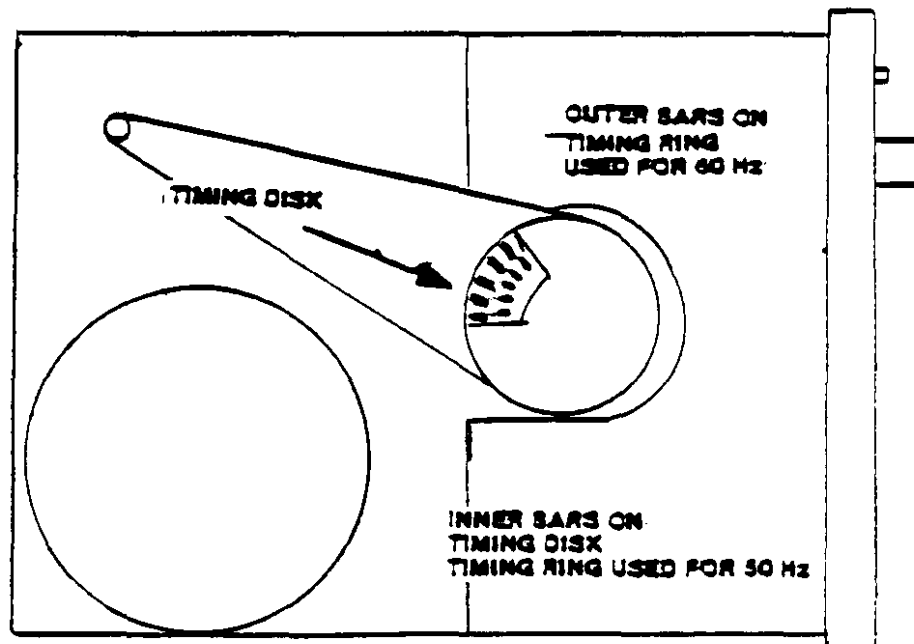

FIGURE 5-4

BOTTOM VIEW OF DRIVE

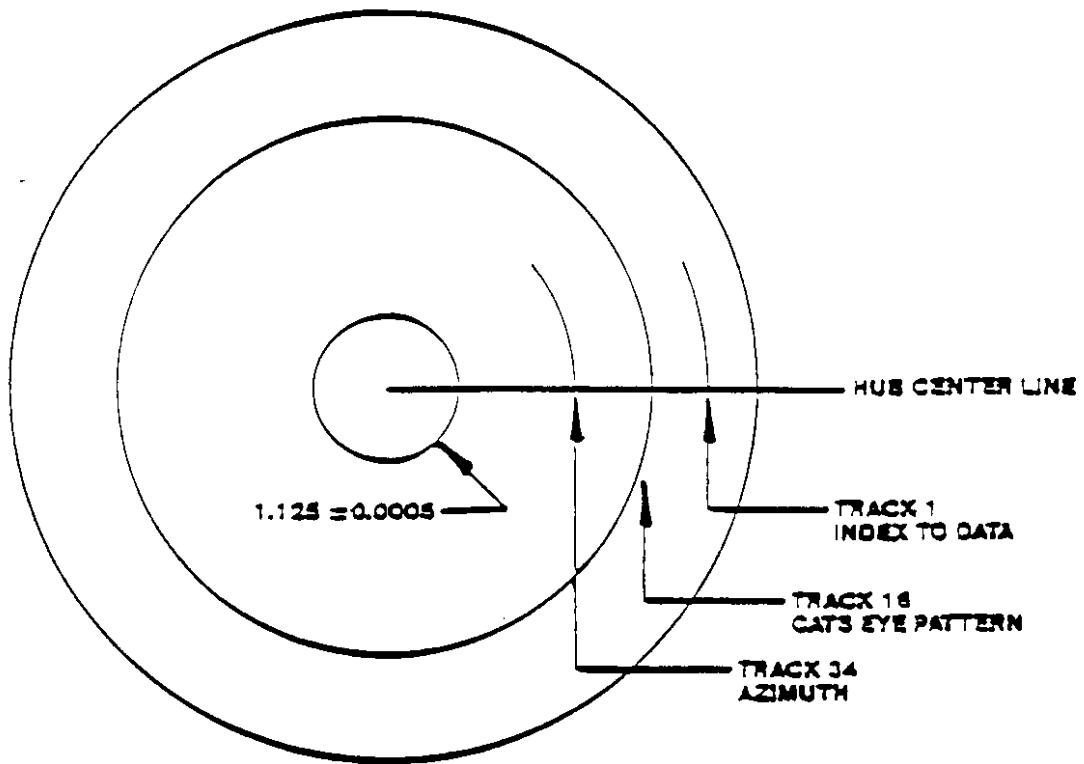

FIGURE 5-5

HUB CENTER LINE AND TRACK LOCATION

NOTE

THE ALIGNMENT DISKETTE AND DRIVE MUST BE ALLOWED TO STABILIZE AT ROOM TEMPERATURE FOR ONE HOUR BEFORE CHECKS AND ADJUSTMENTS ARE PERFORMED.

Radial Track Alignment Check

1. Set up oscilloscope

Channel A: Test Point 4

Channel B: Test Point 5

Ground: Test Point 8 or 14

Read Differentially: A plus B, B inverted

Time Base: 20 milliseconds per division

External Trigger: Test Point 12, positive edge

Adjust amplitude for at least four divisions on the oscilloscope, A. C. coupled.

2. Apply power to the drive.

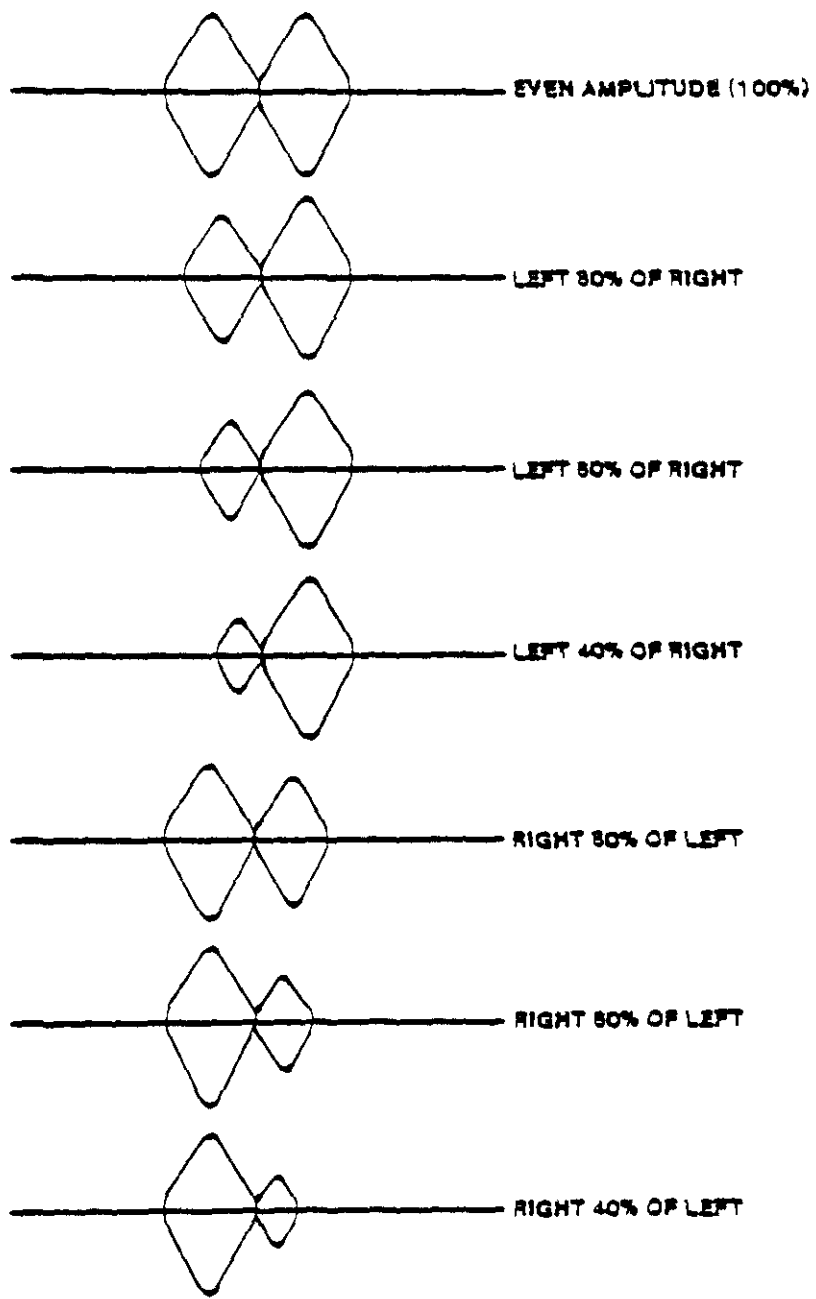

FIGURE 5-6  
CATS EYE PATTERNS

NOTE

THE TRACK 16 RADIUS IS 1.9167 INCHES FROM THE CENTER OF THE HUB. OTHER TRACK LOCATIONS ARE COMPUTED BASED UPON 48 TPI.

3. Select the drive.
4. Insert a certified alignment diskette, Dysan Number 224/2A, into the drive.
5. Select Head 0, the lower head.
6. Read Track 16 for Radial Track alignment of the lower head.
7. Adjust the oscilloscope to observe a Cats Eye pattern (Figure 5-6).
8. Verify the smaller of the two Cats Eye patterns is not less than 75 percent in amplitude of the other one.

NOTE

THE 75 PERCENT FIGURE IS FOR USE WITH AN ALIGNMENT DISKETTE VERIFIED AGAINST A STANDARD ALIGNMENT DISKETTE.

9. Step the drive to Track 0; then, step it back to Track 16.
10. Verify the Cats Eye pattern.
11. Step the drive to Track 26 or higher; then, step it back to Track 16.
12. Verify the Cats Eye pattern.
13. Switch to Head 1, the upper head.
14. Read Track 16 to verify the alignment of the upper head, if applicable.
15. Verify the Cats Eye pattern.
16. Step the drive to Track 0; then, step it back to Track 16.
17. Verify the Cats Eye pattern.
18. Step the drive to Track 26 or higher; then, step it back to Track 16.
19. Verify the Cats Eye pattern.
20. If all the checks verify, the radial track alignment is acceptable.
21. If any check does not verify, the stepper motor must be adjusted.

## Radial Track Alignment Adjustment

1. Loosen the two Number 1 Phillips retaining screws on the stepper motor (see Figure 5-7).
2. Using a flat blade screwdriver between the chassis camming bar and the stepper motor, rotate the stepper motor.
3. Observe the Cats Eye pattern of the head farthest out of alignment.
4. Adjust until the Cats Eye patterns are equal in amplitude (Figure 5-6).
5. Tighten the stepper motor retaining screws.
6. Recheck the Radial Track alignment.

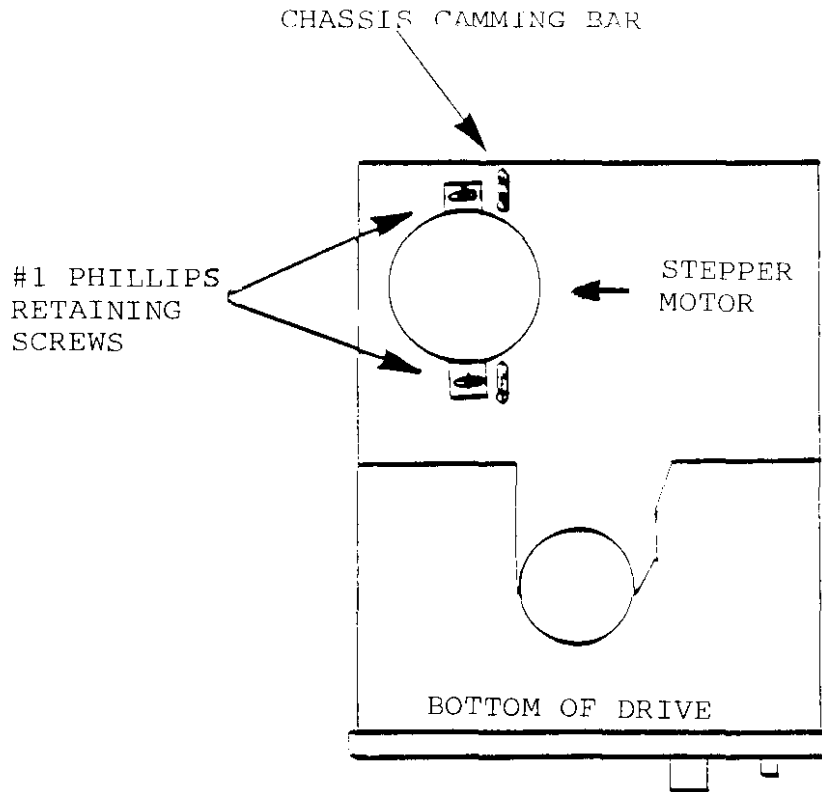

FIGURE 5-7

### STEPPER MOTOR RETAINING SCREWS AND CAMMING BARS

## 5.7 INDEX CHECKS AND ADJUSTMENT

The index adjustment changes the time period from the index pulse to the start of the data in hard sector diskettes. The adjustment should be checked after the drive has been aligned or when diskette interchange errors are suspected.

## Index-To-Data Pulse Checks

1. Set up oscilloscope

Channel A: Test Point 4

Channel B: Test Point 5

Ground: Test Point 8 or 14

Read Differentially: A plus B, B inverted

Time Base: 50 microseconds per division

External Trigger: Test Point 12, negative edge

### NOTE

THE TOLERANCE IS  $200 \pm 100$  MICROSECONDS.

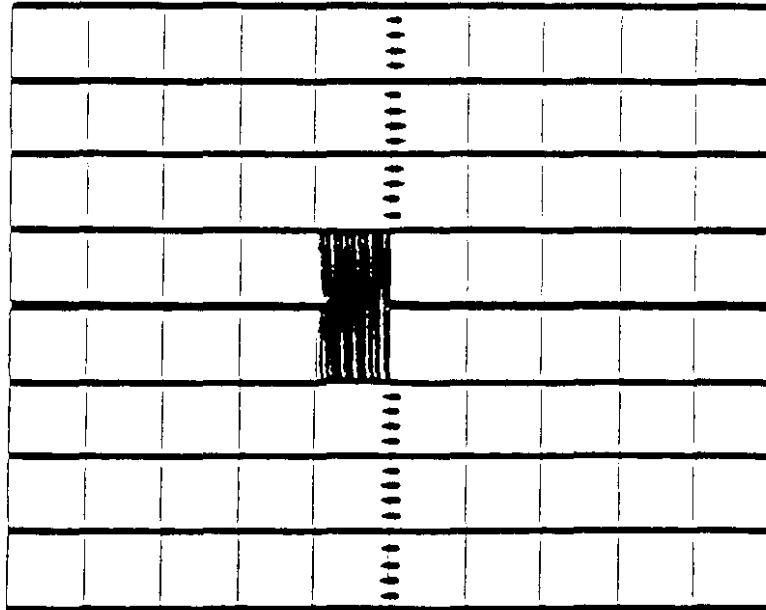

TIME SCALE: 50 MICROSECONDS PER DIVISION

FIGURE 5-8

### INDEX-TO-DATA PULSE

2. Adjust amplitude for at least two divisions on the oscilloscope.
3. Apply power to the drive.
4. Select the drive with the control logic.
5. Check the speed of the drive's motor.
6. Insert an alignment diskette.

7. Seek the carriage to Track 1.
8. Select Head 0.
9. Read the trigger point to the start of the first data pulse width (Figure 5-8).
10. For double-sided drives, if Head 0, the lower head, meets the tolerance, check the upper head.

NOTE

HEAD 1 SHOULD MEET THE SAME TOLERANCE.

11. If either head does not meet the tolerance, adjust the index sensor.
12. Recheck both indexes after they are adjusted.
13. When both index measurements on a double-sided drive or the one index measurement on a single-sided drive meet the tolerance, check the index on Track 34.
14. For double-sided drives, check Heads 0 and 1.

NOTE

IF ANY INDEX MEASUREMENT DOES NOT MEET THE TOLERANCE, THE INDEX SENSOR MUST BE ADJUSTED.

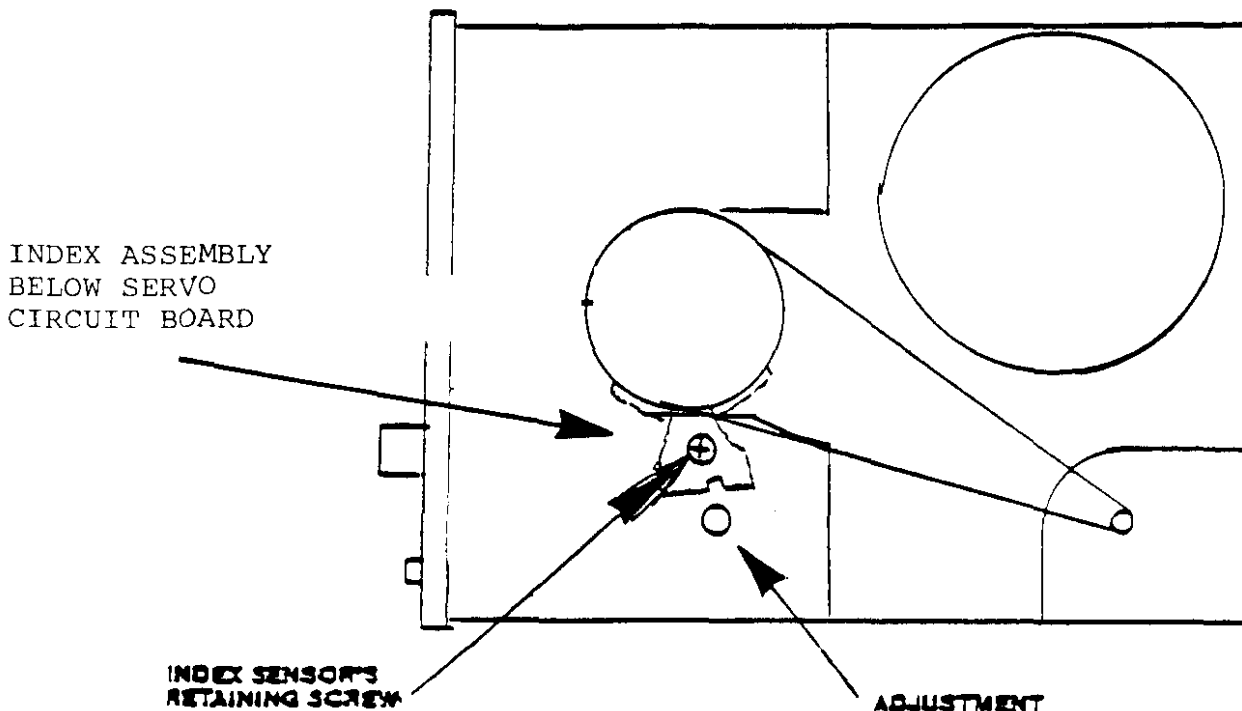

FIGURE 5-9

INDEX SENSOR'S RETAINING SCREW AND ADJUSTMENT



15. Recheck all indexes after each adjustment.

### Index Sensor Adjustment

1. From the bottom of the chassis, loosen the index sensor's retaining screw counterclockwise one-quarter turn (Figure 5-9), through the access hole in the Servo circuit board.
2. Adjust the index sensor with a flat blade screwdriver until the data pulse begins 200 microseconds  $\pm$  100 microseconds from the trigger point, through the access hole in the servo circuit board.
3. Tighten the index sensor's retaining screw.
4. Recheck the index-to-data pulse.

### 5.8 AZIMUTH CHECK

Azimuth checks the read/write head's relative angle to the center line of the diskette. The Dysan 224/2D alignment diskette has three azimuth bursts, the first one having acceptable limits of 12 minutes; the second one, 15 minutes; and the third one, 18 minutes. The third burst of 18 minutes should be used for the check.

The head's azimuth is not adjustable. If the head(s) fail the azimuth check, replace the head carriage assembly.

1. Set up the oscilloscope  
Channel A: Test Point 4  
Channel B: Test Point 5  
Ground: Test Point 8 or 14  
Read Differentially: A plus B, B inverted  
Time Base: 0.5 millisecond per division  
External Trigger: Test Point 12, positive edge  
Adjust the amplitude for at least four divisions on the oscilloscope.
2. Seek to Track 34.
3. Select Head 0, and observe the third pulse burst on the oscilloscope.
4. Verify the head azimuth is no greater than  $\pm$  18 minutes by comparing the third set of pulse burst to those in Figures 5-10, 5-11, and 5-12.

5. Select Head 1, and verify the head azimuth. Figure 5-10 depicts an azimuth of exactly zero minutes. This is the optimum head azimuth alignment.

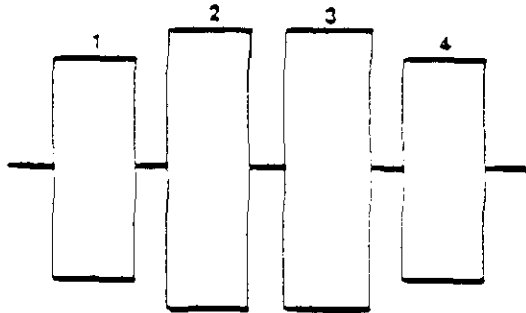

FIGURE 5-10

OPTIMUM HEAD AZIMUTH ALIGNMENT

Figure 5-11 depicts an azimuth of exactly minus 18 minutes. This is the lower limit of allowable azimuth error.

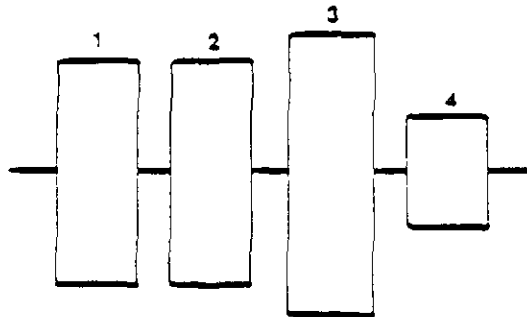

FIGURE 5-11

HEAD AZIMUTH ALIGNMENT OF ACCEPTABLE LOWER LIMITS

Figure 5-12 depicts an alignment of exactly plus 18 minutes. This is the upper limit of allowable azimuth error.

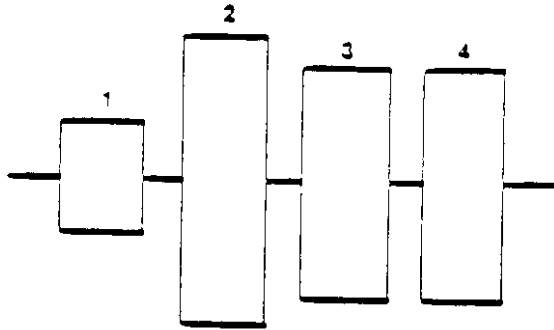

FIGURE 5-12

HEAD AZIMUTH ALIGNMENT OF ACCEPTABLE UPPER LIMITS

5.9 TRACK 0 SENSOR CHECK AND ADJUSTMENT

The Track 0 sensor circuitry provides a signal identifying Track 0 to the logic electronics. The electronics disable the step-out function when Track 0 is reached. In addition, a Track 0 signal is sent to the controller on Pin 26 of the interface.

Track 0 Sensor Check

1. Set up the oscilloscope
  - Channel A: Test Point 4
  - Channel B: Test Point 5
  - Ground: Test Point 8 or 14
  - Read Differentially: A plus B, B inverted
  - Time Base: 20 milliseconds per division
  - External Trigger: Test Point 12, positive edge
  - Vertical Display: 0.1 volt per division
2. Apply power to the drive.
3. Insert a certified alignment diskette into the drive.
4. Close the front latch.
5. Step the carriage to the radial alignment track.

6. Confirm the position by observing the Cats Eye pattern.
7. Set up the oscilloscope to monitor the TTL signal at IC U8, Pin 4.
8. Step the carriage back to Track 1.
9. Ensure the signal at Track 1 is at least 2.5 volts.
10. Step the carriage out to the radial alignment track.
11. Step the carriage back to Track 2.
12. Verify the logic level at IC U8, Pin 4, is less than 0.8 volt.
13. If all of these checks are satisfactory, no adjustment is required.
14. If any of these checks is unsatisfactory, adjust the Track 0 Sensor.

#### Track 0 Sensor Adjustment

1. Loosen the retaining screws on the base of the Track 0 sensor.
2. Retighten the screw on the spindle side of the sensor to provide some friction on it. The screw at the rear of the sensor is for the Track 0 stop (see Figure 5-13).
3. Move the sensor to the rear of drive as far as it will go.
4. Step the carriage back from the radial alignment track to Track 1, but do not restore it to Track 0.
5. Slide the Track 0 sensor toward the spindle very slowly until the signal at IC U8, Pin 4, is at least 2.5 volts at Track 1 and less than 0.8 volt at Track 2. Chassis camming bars are located at the front and the rear of the sensor.
6. Retighten the screw on the spindle side of the sensor.
7. Repeat the Track 0 sensor check to ensure the correct setting has been attained.

#### 5.10 TRACK 0 STOP ADJUSTMENT

The Track 0 stop screw should be adjusted after the Cats Eye pattern has been adjusted, or when the carriage seeks to a track lower than Track 0.

1. Set up the oscilloscope
  - Channel A: Test Point 4
  - Channel B: Test Point 5
  - Ground: Test Point 8 or 14
  - Read Differentially: A plus B, B inverted
  - Time Base: 20 milliseconds per division
  - External Trigger: Test Point 12
2. Apply power to the drive.
3. Select the drive.
4. Insert an alignment diskette.
5. Loosen Number 1 Phillips screw at rear of Track 0 sensor. Track 0 stop block slides inside of Track 0 sensor. See Figure 5-13.
6. Step the carriage to Track 0, and observe the waveform.
7. Slowly push the Track 0 stop block into Track 0 sensor until the output amplitude begins to decrease on the oscilloscope.
8. Slowly retract the Track 0 stop block until amplitude stops increasing. Retract it an additional 1/32 of an inch. Tighten the Track 0 stop block screw.

#### 5.11 HEAD OUTPUT CHECK

The head output check measures the head's output amplitude relative to the diskette being used. When using certified, quality media, typical values will be 200 millivolts peak-to-peak or greater. However, values may be significantly less, 100 millivolts peak-to-peak typical, if inferior or defective media is used, and does not indicate a faulty head.

Head amplitude can be verified by establishing a nominal value of amplitude for the diskette on a known working drive. In all cases, amplitudes greater than 200 millivolts peak-to-peak are acceptable.

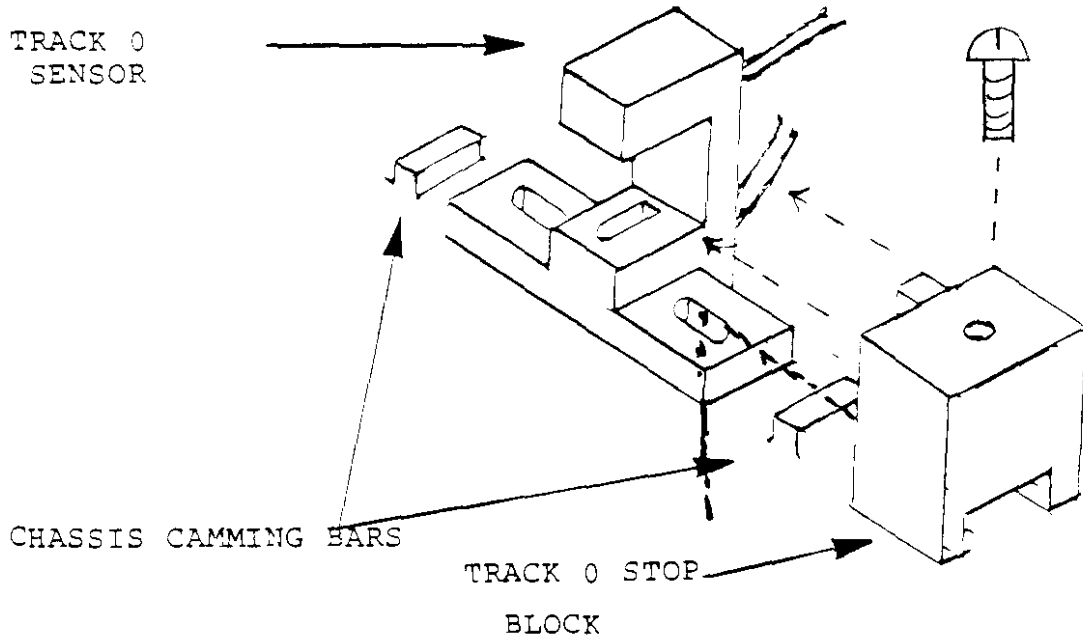

FIGURE 5-13

TRACK 0 STOP

1. Remove the alignment diskette, and insert a nonwrite protected diskette into the drive.
2. Set up the oscilloscope
  - Channel A: Test Point 4
  - Channel B: Test Point 5
  - Vertical Amplitude: 50 millivolts per division
  - Ground: Test Point 8 or 14
  - Read Differentially: A plus B, B inverted
  - Time Base: 20 milliseconds per division
  - External Trigger: Test Point 12
3. Seek to Track 39.
4. Write a 2F, all ones, pattern on Head 0.
5. Verify the amplitude is 200 millivolts or greater, peak-to-peak.
6. Write a 2F, all ones, pattern on Head 1.
7. Verify the amplitude is 200 millivolts or greater, peak-to-peak.

## 5.12 CONE CENTERING CHECK

Cone centering is the ability of the cone clamping mechanism to center the diskette on the hub, causing it to rotate concentrically. This check and adjustment should be made whenever the upper plate assembly has been removed or replaced. If the cone centering cannot be adjusted, verify the measurement with a second diskette.

1. Set up the oscilloscope:
  - Channel A: Test Point 4
  - Channel B: Test Point 5
  - Vertical Amplitude: 100 millivolts per division
  - Ground: Test Point 8 or 14
  - Read Differentially: A and B, B inverted
  - Time Base: 20 microseconds per division
  - External Trigger: Test Point 12, positive edge
2. Apply power to the drive.
3. Select the drive.
4. Seek to Track 0.
5. Write a 2F pattern on Head 0.
6. Measure the amplitude of the signal by positioning the deepest dip in the signal on the center vertical graticule.
7. Release the front latch, and remove the diskette.
8. Reinsert the diskette, and close the front latch.
9. Repeat Steps 7 and 8 until the deepest dip in the waveform is produced.
10. Measure the amplitude of the deepest dip.
11. Divide this measurement by the measurement in Step 6, and multiply it by 100. This result should be above 85 percent.
12. The signal amplitude should not decrease below 85 percent of the average amplitude at any point on the track.

### 5.13 COMPLIANCE CHECK AND ADJUSTMENT (SINGLE-SIDED DRIVES)

Compliance is the maximized output of the head when the pressure of the felt pad is centered over the read/write gap. For double-sided drives, a compliance check and adjustment must be made at the factory.

#### Compliance Check

1. Set up the oscilloscope:  
Channel A: Test Point 4  
Channel B: Test Point 5  
Vertical Amplitude: 100 millivolts per division  
Ground: Test Point 8 or 14  
Read Differentially: A and B, B inverted  
Time Base: 10 microseconds per division  
External Trigger: Test Point 12, positive edge
2. Apply power to the drive.
3. Select the drive.
4. Insert a nonwrite protected diskette.
5. Write a 1F pattern on Track 34.
6. Observe the output waveform voltage.
7. With a gram gauge, carefully apply fifteen grams pressure to the upper arm.

#### NOTE

FIFTEEN GRAMS IS ABOUT THE WEIGHT OF A QUARTER.

8. If the output shown on the oscilloscope increases by more than ten percent, adjust the compliance.



## Compliance Adjustment

Compliance is adjusted by using the same procedure used in the compliance check.

In addition:

1. The spring tension for the pad arm has three positions for the spring end in the lower portion on the head carriage assembly (see Figure 5-14).
2. While monitoring the oscilloscope, change the spring tension position. If output amplitude is not affected by different positions of the spring, replace it.
3. If the pad is worn, replace it.

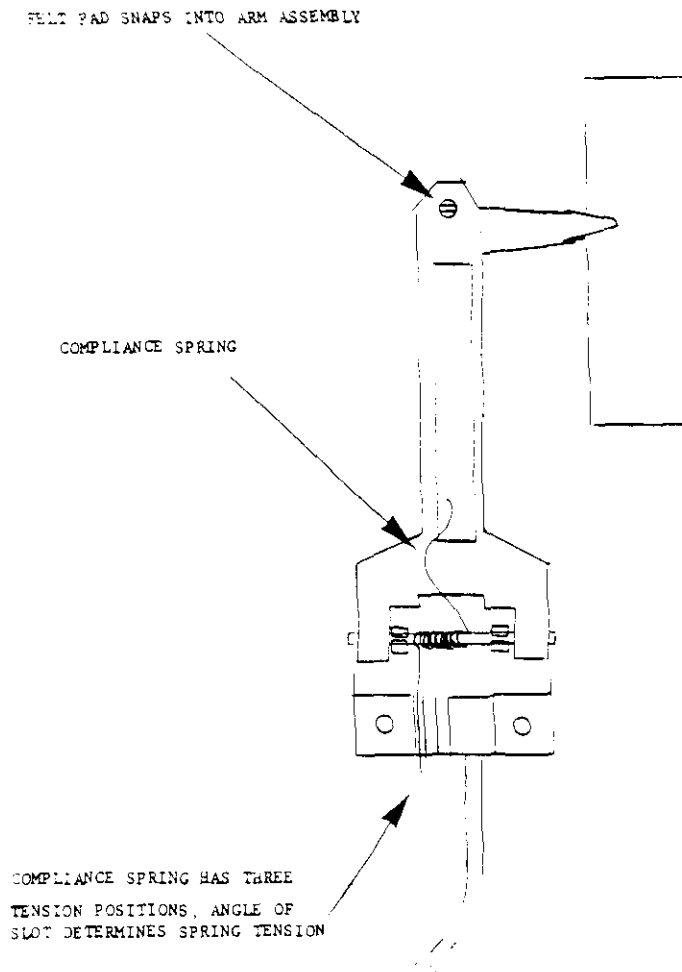

FIGURE 5-14

UPPER ARM AND COMPLIANCE SPRING

## SECTION 6

### REMOVAL AND INSTALLATION

Removal and installation instructions are included in this section.

1. Control and Data Circuit Board
2. Servo Circuit Board
3. Chassis Shield
4. Diskette Lever Assembly
5. Front Panel
6. Power Input Plug and Bracket
7. Write Protect Switch
8. Write Protect Sensor
9. Stepper Band
10. Stepper Motor
11. Upper Plate Assembly
12. Track 0 Sensor and Stop Block
13. Head Module
14. Drive Belt
15. Drive Motor

## CONTROL AND DATA CIRCUIT BOARD

### Removal -

1. Disconnect all cable plugs from the circuit board located on top of the drive.
2. Remove two Number 1 Phillips screws at the rear of the circuit board.
3. Lift off the drive.

### Installation

1. Position the circuit board on top of the drive.
2. Secure the circuit board with the two previously saved screws.
3. Connect all cable plugs (Figure 6-1).

## SERVO CIRCUIT BOARD

### Removal

1. Position drive with drive belt on top; disconnect all cable plugs from the circuit board.
2. Remove the Number 1 Phillips screw at the left front and the Number 1 Phillips screw going through the heat sink on the circuit board.

#### NOTE

THIS IS LONGER THAN THE OTHER SCREW REMOVED.

3. When removing the circuit board, do not break off the L. E. D. attached to the edge of it, and do not stretch the drive belt.

#### NOTE

IF THE WRITE PROTECT CIRCUIT IS A SENSOR ATTACHED TO THE CIRCUIT BOARD, USE CARE WHEN REMOVING IT.

### Installation

1. Position the circuit board with the L. E. D. lined up to the retaining cavity on the front panel. Insert the L. E. D. and move the belt slightly to position the circuit board.

2. Secure the circuit board using the short Number 1 Phillips screw through the mounting hole at the front. The longer Number 1 Phillips screw is used through the heat sink on the circuit board.
3. Connect all cable plugs (Figure 6-2).

#### CHASSIS SHIELD, CONTROL AND DATA CIRCUIT BOARD

##### Removal

1. Remove the control and data circuit board.
2. Remove the Number 1 Phillips screw's retaining shield.

##### NOTE

HEAD CABLING IS AT THE FRONT OF THE DRIVE.

3. Lift the shield from the chassis.

##### Installation

1. Position the head cables along the chassis to exit the slot of the shield at the front of the drive.
2. Position the shield, securing it with a Number 1 Phillips screw through the mounting hole.
3. Replace the circuit board.

#### DISKETTE LEVER ASSEMBLY

##### Removal

1. Using a flat blade screwdriver, pry off the plastic door handle (Figure 6-3).
2. Remove the stud from the door shaft.

##### Installation

1. Replace the stud in the door shaft.
2. Position the door handle over the shaft and stud.
3. Press in until the stud is covered by the door handle.

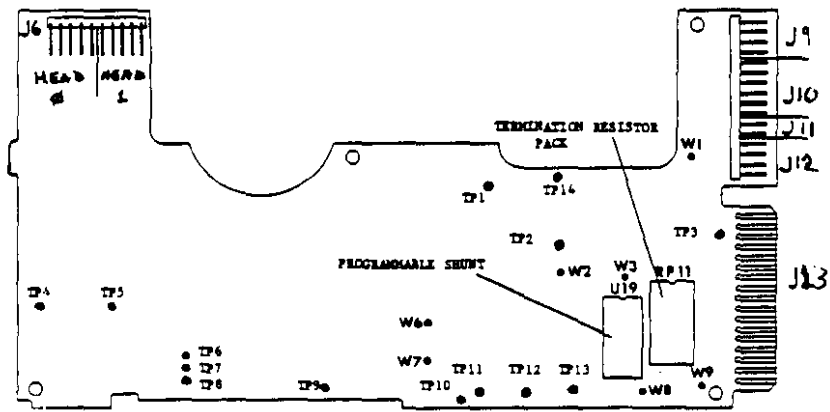

FIGURE 6-1

CONTROL AND DATA CIRCUIT BOARD

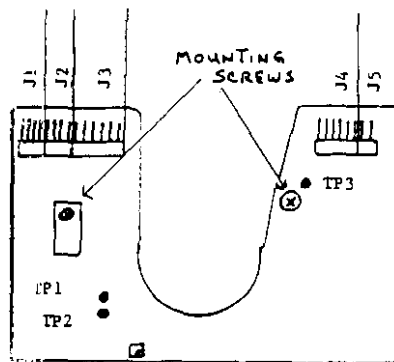

FIGURE 6-2

SERVO CIRCUIT BOARD

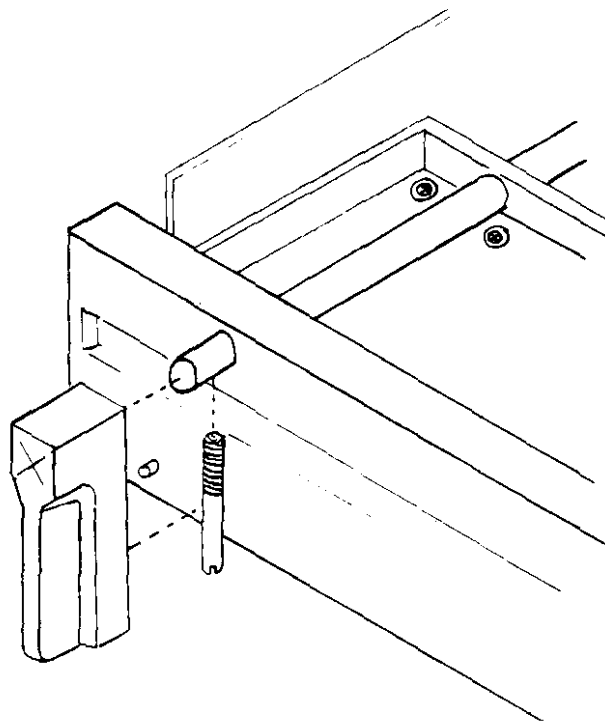

FIGURE 6-3

DISKETTE LEVER ASSEMBLY

## FRONT PANEL

### Removal

1. Remove the diskette lever assembly.
2. The front panel is held in place by small plastic ridges. To remove them from the bottom, pull down and out. To remove them from the top, upper plate assembly, pull up and out, and slide them off of the door shaft.

### Installation

1. Position the front panel over the door shaft and activity L. E. D., and push it hard. The front panel snaps onto the chassis and upper plate assembly.

## POWER INPUT PLUG AND BRACKET

### Removal

1. Remove the control and data circuit board.
2. Remove the chassis shield.
3. Remove the Number 1 Phillips screw from the power input retaining bracket (Figure 6-4).

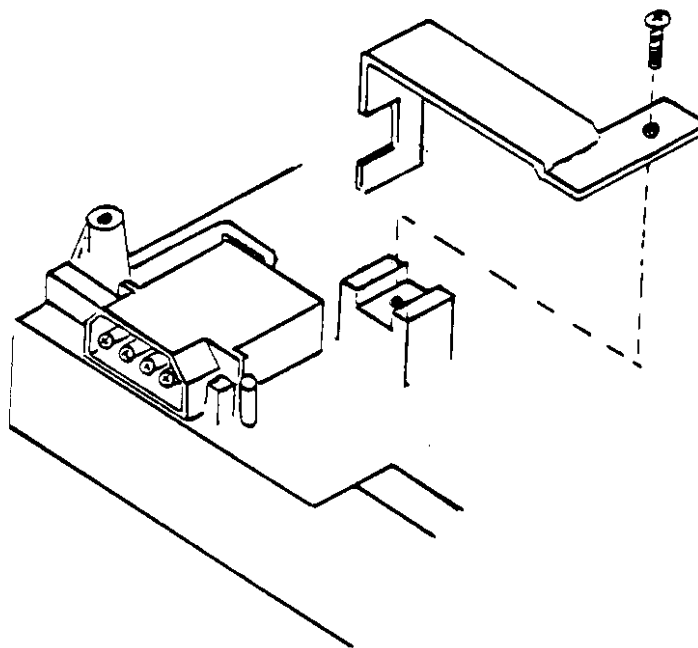

FIGURE 6-4

POWER INPUT PLUG AND BRACKET

4. Push the bracket to the front of the drive, and remove it.
5. The power input plug has two cables running from it: plug Number 2 is to the servo circuit board on the bottom of drive; Plug Number 7, on top of the drive, is to the control and data circuit board. Disconnect both plugs and remove them from the drive.

### Installation

1. Position the power input plug on the chassis with rounded corners to the top and next to the chassis retaining forms.
2. Route cable plug Number 2 through the hole in the chassis to the bottom of drive. Cable plug Number 7 remains on the same side as the power input plug.

### CAUTION

THESE CABLE PLUGS CANNOT BE REVERSED. POWER APPLIED IS NOT THE SAME PIN OUTS ON THE CIRCUIT BOARD.

3. Put the bracket over the hole in the chassis, and line it up with the power input plug. The bracket must engage with the chassis through the hole. The power input plug goes against the chassis retaining forms.
4. Secure the bracket with a Number 1 Phillips screw into the chassis standoff.
5. Replace the chassis shield.
6. Replace the control and data circuit board.

### WRITE PROTECT SWITCH

### Removal

1. Remove P11 from the control and data circuit board.
2. Cut the tie wraps, as required, to route Plug P11 through the hole in the chassis to the bottom of the drive.
3. Remove the servo circuit board.

4. At the lower left front side of the drive, loosen the two Number 1 Phillips screws retaining the write protect switch, actuating arm, and screw retaining plate.
5. Slide the assembly off of the chassis.

### Installation

1. After positioning the write protect switch and actuating arm, screw the retaining plate into the chassis slot.
2. After ensuring the actuating arm is in the chassis' slot, tighten the two screws.
3. Route cable plug P11 through the hole in the chassis toward the rear of the drive, around the outside of the drive motor to the control and data circuit board.
4. Replace the tie wrap.
5. Replace the servo circuit board.

### WRITE PROTECT SENSOR

#### Removal

1. Remove the servo circuit board.

#### NOTE

ONE-HALF OF THE SENSOR IS ATTACHED TO  
THE PHOTOTRANSISTOR.

2. At the top left-hand front of the drive, the write protect sensor's diode mounting block is retained by a Number 1 Phillips screw. Remove the screw and cut the tie wraps, as required, to remove Plug P11 from the control and data circuit board.
3. Remove the sensor's diode.

#### Installation

1. Replace the servo circuit board.



2. Align the mounting block with the sensor over the hole on the top, left-hand front of the drive, and secure it with a Number 1 Phillips screw.
3. Route the cables and plug P11 into the connector on the control and data circuit board.
4. Wrap the cables, as required.

## STEPPER BAND

### Removal

1. Remove the control and data circuit board.
2. Remove the chassis shield.
3. Remove the power input plug.
4. Loosen the Number 1 Phillips screw on the stepper motor shaft (Figure 6-5).

### CAUTION

WHILE HOLDING THE HEAD ASSEMBLY DURING REMOVAL OF THE STEPPER BAND, TAKE CARE TO PROTECT THE UPPER HEAD ASSEMBLY.

5. Holding the head assembly toward the rear of the drive, depress the spring tension plate at the rear of the head assembly toward the stepper shaft to the front of the drive. The stepper band will detach from the clip portion of the tension plate.

### CAUTION

DO NOT BEND THE STEPPER BAND.

6. Remove the tension plate and the spring from the head assembly.
7. Remove the screw from the stepper motor shaft.

### CAUTION

DO NOT BEND THE STEPPER BAND.

8. Lift the stepper band from the stud at the front of the head assembly and from the stepper shaft.

## Installation

1. Place the stepper band with its single part toward the front of the head assembly.
2. Place a loop around the stepper shaft with its dual portion toward the rear of the drive.
3. Place the stepper band on the stud of the head assembly.
4. Rotate the stepper motor until the center hole in the stepper band and the hole in the shaft line up together.
5. Install the screw and washer into the stepper shaft but do not tighten the screw.
6. Install the spring and tension plate onto the head assembly.
7. Holding the head assembly toward the rear of the drive, depress the tension plate toward the front of the drive.
8. After setting the end of the stepper band onto the tension plate, remove the pressure from the plate. The stepper band seats itself around the stepper motor shaft.
9. Move the head assembly to obtain the maximum length of travel while watching the stepper band on the stepper motor shaft. If it maintains a straight path, it is o. k. If not, relax the tension plate, and try to smooth out the stepper band.

### CAUTION

TIGHTENING THE SCREW TOO TIGHT WILL BEND THE STEPPER BAND, CAUSING IT TO NEED REPLACING.

10. When satisfied with stepper band operation, snug up the stepper motor shaft screw to four-inch ounces of torque.
11. Replace the power input plug.
12. Replace the chassis shield.
13. Replace the control and data circuit board.

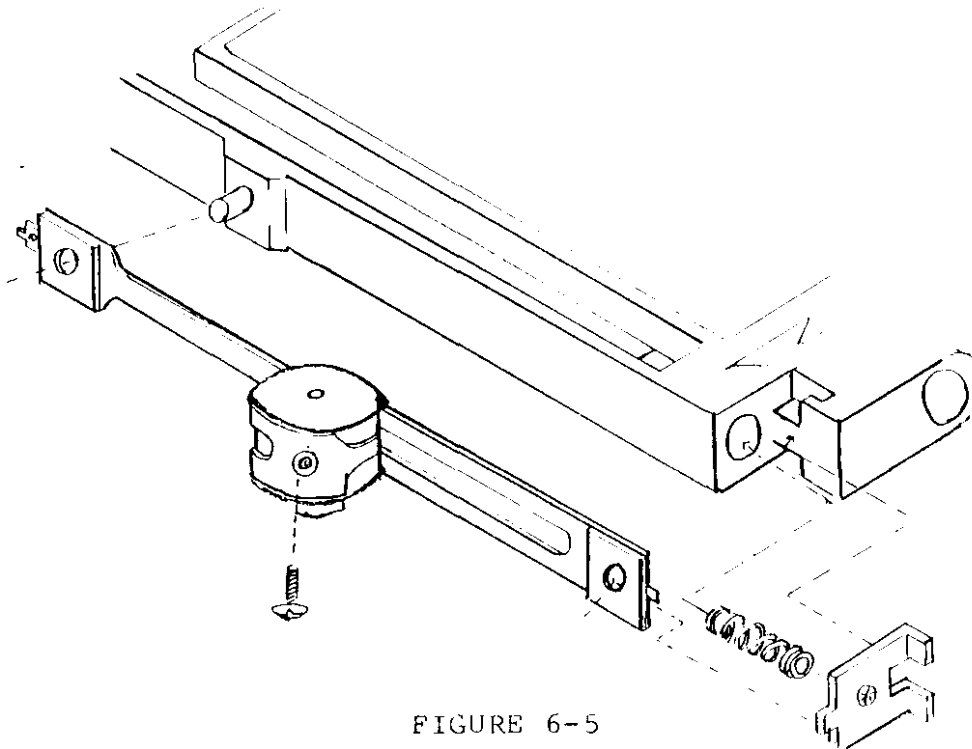

FIGURE 6-5  
STEPPER BAND

## STEPPER MOTOR

### Removal

1. Remove the control and data circuit board.
2. Remove the chassis shield.
3. Remove the stepper band.
4. Remove the stepper motor cable plug, P3, from the servo circuit board.
5. Remove the two Number 1 Phillips screws on the bottom of the drive, one at each end of the stepper motor.
6. The screw toward the front of drive has a wire wrap covered with shrink tight and two tie wraps. Cut the two tie wraps.
7. Remove the stepper motor from the chassis.

### Installation

1. Position the stepper motor shaft through the hole in the chassis.
2. Insert retaining screws and washers. The retaining screw toward the front of the drive has a wire wrap covered with shrink tight.
3. Route excess wiring from the stepper motor to the side of the chassis.

4. Insert stepper motor cable plug P3 into the servo circuit board.
5. Tie wrap the cables.
6. Replace the stepper band.
7. Replace the chassis shield.
8. Replace the control and data circuit board.

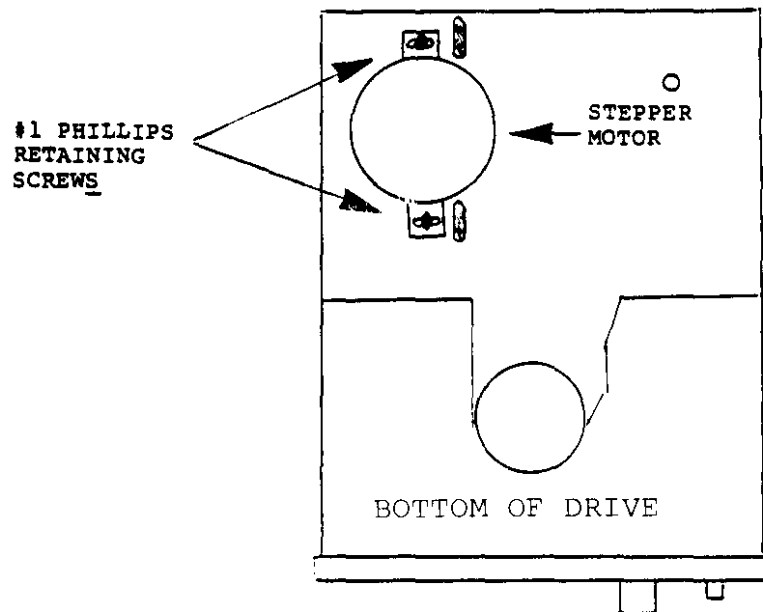

FIGURE 6-6  
STEPPER MOTOR

## UPPER PLATE ASSEMBLY

The upper plate assembly includes the door switch, the upper index sensor, the cone lever assembly, the diskette ejector, the lift plate, and the diskette lever assembly, as well as the write protect sensor, if applicable.

### Removal

1. Remove the control and data circuit board.
2. Remove the chassis shield.
3. Remove the diskette lever assembly.
4. Remove the front panel.
5. Remove the servo circuit board.
6. Remove the bottom index sensor.
7. Cut the tie wraps on the cables for the door switch, Plug 5, the index assembly, Plug 12, and write protect, Plug 11, if the sensor is mounted on the upper plate assembly (Figure 6-7).

### NOTE

ONE-HALF OF THE INDEX ASSEMBLY IS ON THE BOTTOM OF THE DRIVE. THE INDEX ASSEMBLY SHOULD BE ROUTED THROUGH A HOLE IN THE CHASSIS BEFORE REMOVING THE UPPER PLATE ASSEMBLY.

8. Remove the spring from the lift plate.
9. Remove three Number 1 Phillips screws from the upper plate assembly. Two are at the front of the drive, and one is on the drive motor side of the chassis.

### CAUTION

WHEN REMOVING THE UPPER PLATE ASSEMBLY, DO NOT BEND THE UPPER ARM OF THE HEAD ASSEMBLY SINCE DAMAGE CAN RESULT.

### Installation

1. Position the upper plate assembly with the lift plate under the upper arm of the head assembly, and the mounting holes lined up to the chassis.

2. Insert three Number 1 Phillips screws, two at the front of the drive, and one at the rear of the drive by the drive motor.
3. Apply four-inch pounds torque, maximum, to the screws.

NOTE

LEAVE THE MOUNTING HOLE ON THE POWER INPUT PLUG SIDE OF THE UPPER PLATE ASSEMBLY EMPTY. THE CHASSIS SHIELDING RETAINING SCREW USES THIS HOLE.

3. Replace the spring on the lift plate.
4. Route the lower index assembly through a hole in the chassis, and mount it on the bottom of the drive.
5. Route the cabling, using the tie wraps provided.
6. Replace the servo circuit board.
7. Replace the front panel.
8. Replace the diskette lever assembly.
9. Replace the chassis shielding.
10. Replace the control and data circuit board.

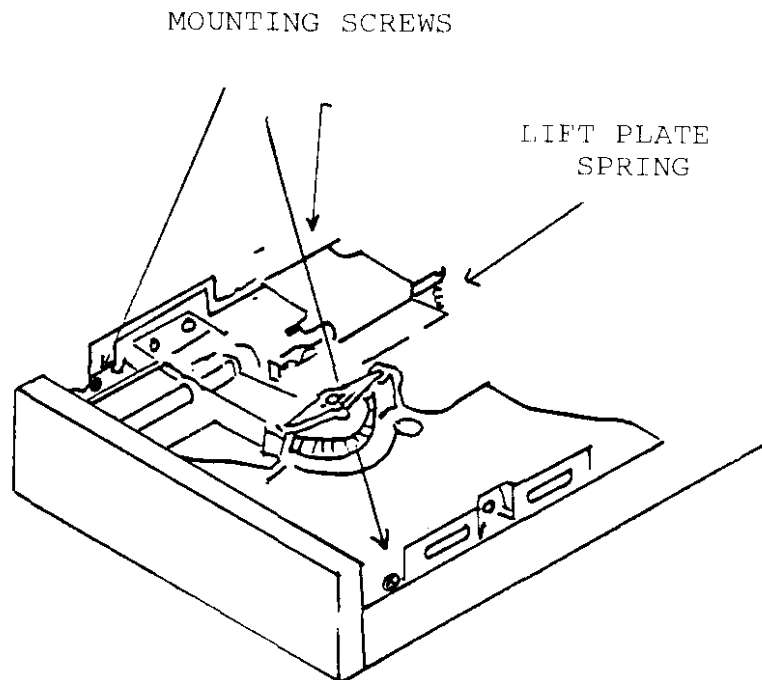

FIGURE 6-7

UPPER PLATE ASSEMBLY

## TRACK 0 SENSOR AND TRACK 0 STOP BLOCK

### Removal

1. Remove cable Plug P9 from the control and data circuit board.
2. Remove the tie wraps, as required, to free the cable to the sensor.
3. Move the head assembly toward the spindle.
4. Remove two Number 1 Phillips screws from the Track 0 sensor (Figure 6-8).

### NOTE

THE SCREW TOWARD THE REAR OF THE DRIVE IS GOING THROUGH TWO PIECES, ONE IS THE TRACK 0 SENSOR, THE SECOND ONE IS THE TRACK 0 STOP BLOCK.

### Installation

1. Position the Track 0 sensor over the retaining holes in the chassis.
2. Insert the retaining screw into the sensor toward the front of the drive.
3. Insert the screw through the Track 0 stop block and into the rear retaining slot of the Track 0 sensor.
4. Slide the Track 0 stop block toward the rear before tightening the screw.
5. Route the cable for the Track 0 sensor back to the control and data circuit board.
6. Apply tie wraps, as required.

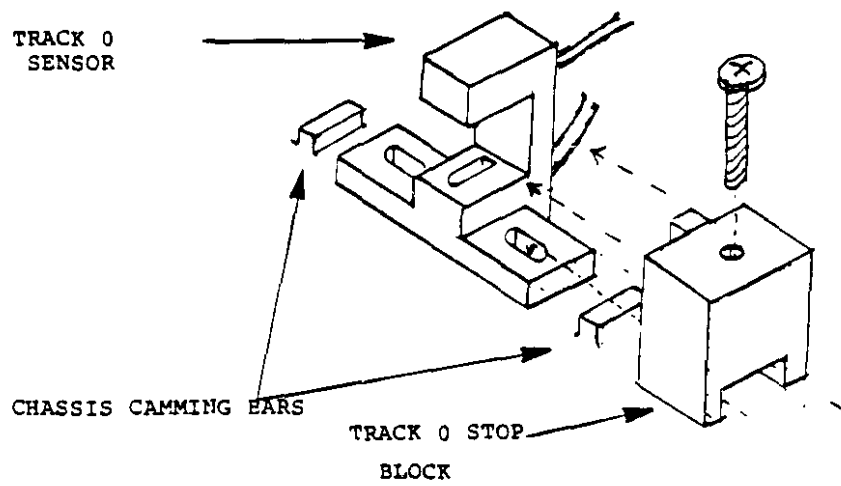

FIGURE 6-8

TRACK 0 SENSOR AND STOP BLOCK



## HEAD MODULE

### Removal

1. Remove the data and control circuit board.
2. Remove the chassis shielding.
3. Remove the power input plug.
4. Remove the stepper band.
5. Remove the Track 0 sensor.
6. At the rear of the drive, remove the V spring which holds two grooved rails.
7. Raise the head assembly slightly, removing it toward the rear of the drive.

### NOTE

FROM THE REAR OF THE DRIVE, THE RAIL ON THE LEFT-HAND SIDE IS ENCASED BY THE HEAD ASSEMBLY CASTING, THE RAIL-HAND SIDE ON THE RIGHT IS RIDING ON THE GUIDE.

### Installation

1. Position the head assembly to slide over and around the guide rails if the V spring clip still has the front of the guide rails attached to the chassis.
2. Insert the clip into the grooves of the rails and the retaining block on the chassis.
3. Slide the head assembly several times on its rails to ensure it does not bind.
4. Replace the Track 0 sensor.
5. Replace the stepper band.
6. Replace the power input plug.
7. Replace the chassis shielding.
8. Replace the data and control circuit board.

## DRIVE BELT

### Removal

1. Remove the control and data circuit board.
2. Remove the chassis shield.
3. Remove the diskette lever assembly.
4. Remove the front panel.
5. Remove the servo circuit board.
6. Remove the bottom index sensor.
7. Remove the upper plate assembly.
8. Unloop the drive belt from the drive motor pulley.
9. Lift out the drive belt through the slot in the chassis.

### Installation

1. Twist the belt so the shiny side is inward.
2. Push the new belt through the slot in the chassis, looping the belt around the spindle pulley.
3. While turning the spindle pulley, loop the other end of the belt around the drive motor pulley.
4. Ensure the spindle pulley, drive belt, and drive motor rotate freely.
5. Replace the upper plate assembly.
6. Replace the bottom index sensor.
7. Replace the servo circuit board.
8. Replace the front panel.
9. Replace the diskette lever assembly.
10. Replace the chassis shield.
11. Replace the control and data circuit board.

## DRIVE MOTOR

### Removal

1. On the servo circuit board, remove cable Plug P1.
2. Cut the tie wrap at the front of the stepper motor (Figure 6-9).
3. Cut the tie wraps by the drive motor on the bottom of the drive, one in the corner of the chassis.
4. Route cable Plug P1 through the hole in the chassis.
5. Remove the belt from the motor pulley.
6. Remove the two Number 1 Phillips screws from the bottom of the drive below the motor.
7. Lift out the motor.

### Installation

1. Insert the new drive motor through the hole in the chassis.
2. Line up the retaining screw holes.
3. The wires from the motor go to the rear of the chassis.
4. Insert and tighten the two retaining screws.
5. Route drive motor cable Plug P1 through the hole in the chassis to the servo circuit board.
6. Connect the cable to the circuit board.
7. Install the tie wraps, as required.
8. Attach the drive belt to the drive motor pulley.
9. Ensure the drive motor, drive belt, and spindle pulley are rotating freely.

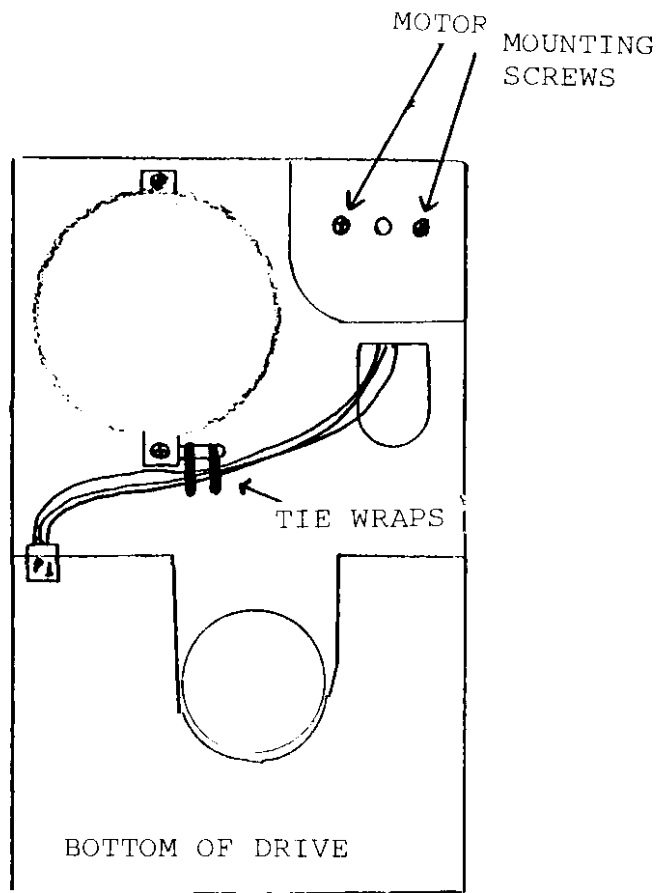

FIGURE 6-9  
DRIVE MOTOR

## APPENDIX A

### RECOMMENDED SPARE PARTS AND MAJOR ASSEMBLIES

This appendix contains the recommended spare parts list and the major assemblies. Part numbers on this list should be used for ordering. A spare parts list with prices for parts and services is available from Tandon Corporation.

Part Number	Description
210375-001	Front Panel Assembly
210309-001	Diskette Lever
211019-001	Write Protect Assembly
210586	Write Protect Assembly (Fast Seek)
210372-001	Upper Plate Assembly
210440-001	Read Write PCBA 48 TPI
210533-001	Drive Motor Assembly
210382-001	Track 00 Sensor Assembly
210340-001	Band Assembly
210384-001	Head Carriage Assembly SSR
210446-001	Head Carriage Assembly DSR
210380-001	Index Sensor Assembly
210534-001	Stepper Assembly
211004-001	Stepper Assembly (Fast Seek)
210334	Drive Belt
210437-002	Motor Control PCBA
210437-003	Motor Control PCBA (Fast Seek)
210399	Drive Hub Assembly

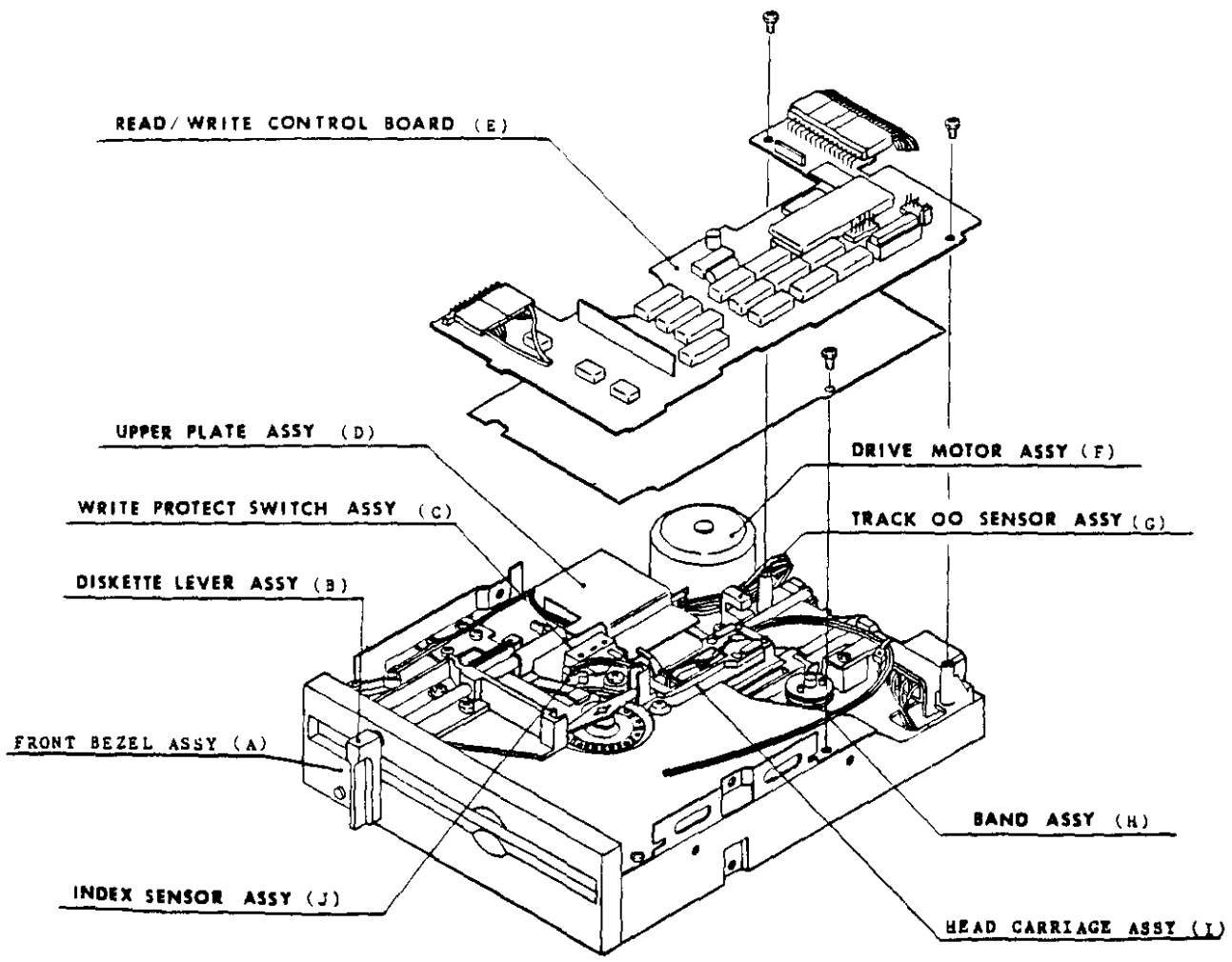

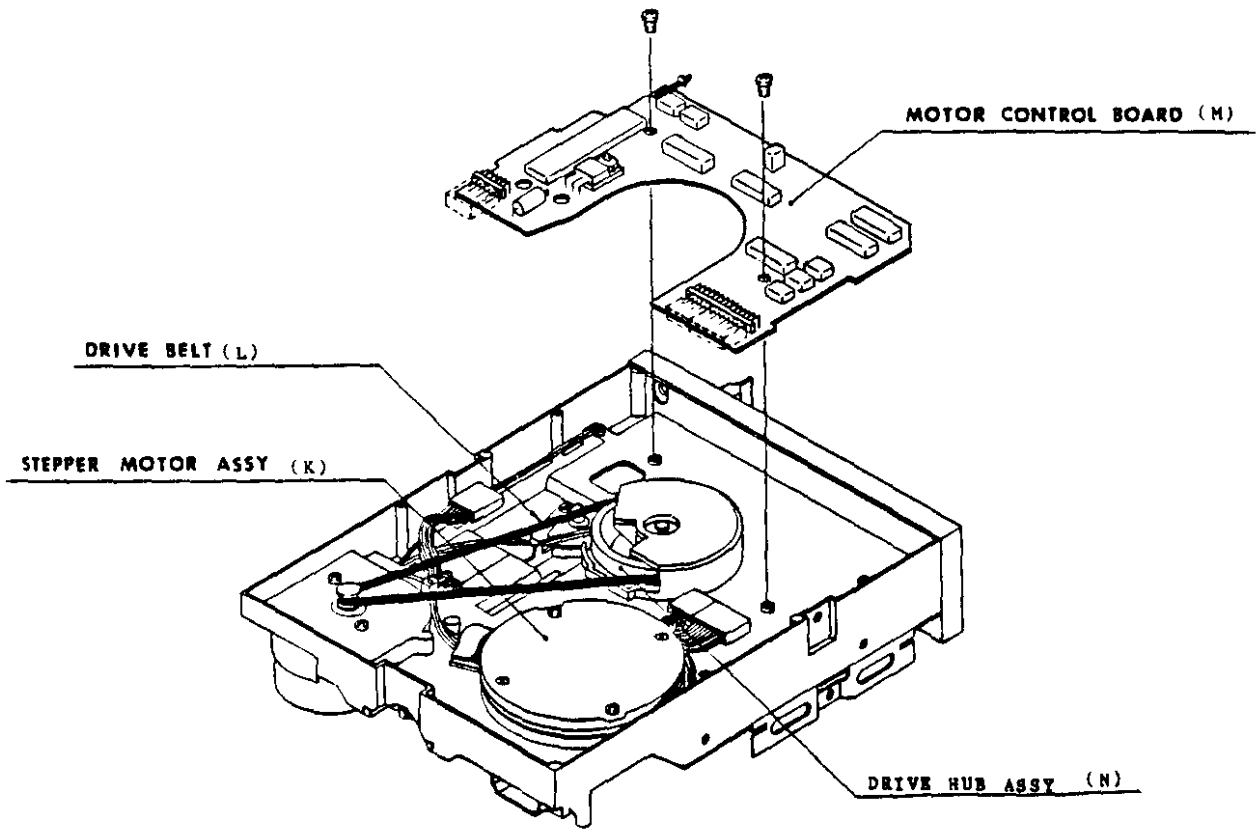

APPENDIX B

CIRCUIT BOARD SCHEMATICS AND DRAWINGS

This appendix contains a listing of the current circuit board schematics and circuit board drawings for the TM50-1 and TM50-2 drives.

<u>Drawing Number</u>	<u>Title</u>	<u>Page Number</u>
210441, -Revision J	Read/Write Logic Circuit Board Schematic	B-1, B-2, B-3, B-4
210439, Revision H	Motor Control Circuit Board Schematic	B-5, B-6, B-7







4

3

2

1

TABLE I

VERSION	VERSION CHARACTERISTIC	CR3 A75001-00	R24 150.0K 1/4 W, 5% 973000-151	C21	R18	C16
-001	STANDARD	OMIT	OMIT	1UF	14.3K 1%	OMIT
-002	W/WRT PROTECT LED	USE	USE	1UF	14.3K 1%	OMIT
-003	FAST SEEK STEPPER MOTR	USE	USE	.47 UF	11.0K 1%	OMIT
-004	W/WRT PROTECT LED/ACCESS MATRIX	USE	USE	1UF	14.3K 1%	.47 UF

REVISIONS						
REV	DESCRIPTION	DATE	DR	CHK	APPR	
E	REVISED PER EO 13094	11/24/83	MG	APL	mm	
F	REVISED PER EO 13195 B	2/17/83	E.A.	APL	mm	
G	REVISED PER EO 13206	3/14/83	MG	APL	mm	
H	REVISED PER EO 13386	8/23/83	JK	APL	mm	

I.C. TABLE	
U1	UDN5712M
U2	UDN5712M
U3	LM2917
U4	7406
U5	7404
U6	7474
U7	74191
U8	74221
U9	75464
U10	LM555

SPARE GATES	
I.C.	QTY
U6	1

LAST USED		
U10	CR3	R24
Q2	C24	TP3

PIN LIST		
CONN NAME	# OF PINS	USE
J1	4	SPINDLE MOTDR
J2	4	POWER
J3	6	STEPPER
J4	6	CONTROL
J5	2	DISKETTE LOADED

FOR PART NUMBER, VALUE & USAGE OF COMPONENTS AFFECTED BY VERSION NUMBER, SEE TABLE I

- 5. C12 USED FOR TEMP COMP.
- 4. ALL DIODES ARE IN 4446
- 3. CAPACITORS ARE IN  $\mu$ F,  $\pm 20\%$
- 2. 1% RESISTORS  $1/8$  W
- 1. ALL RESISTORS ARE IN OHMS,  $1/4$  W, 5%

NOTES: UNLESS OTHERWISE SPECIFIED

<small>THE INFORMATION CONTAINED HEREON IS THE PROPERTY OF TANDON CORPORATION. NO PORTION OF THIS DATA SHALL BE RELEASED, DISCLOSED, USED OR REPRODUCED FOR USE IN PROCUREMENT OR MANUFACTURING WITHOUT SPECIFIC WRITTEN PERMISSION FROM TANDON CORPORATION.</small>		<b>SIGNATURES</b> DR: <i>H. G...</i> 1/28/83 CHK: <i>[Signature]</i> 1/28/83 ENGR: <i>[Signature]</i> 2/1/83 PROJ ENGR:		<b>DATE</b> 1/28/83		<b>Tandon CORPORATION</b>	
<small>UNLESS OTHERWISE SPECIFIED DIMENSIONS ARE IN INCHES</small> TOLERANCES: .XX ± .005 .XXX ± .002 .X ± .001 .X ± .001 BREAK ALL SHARP CORNERS APPROX .010		<b>TITLE</b> MODEL TM-50 MOTOR CONTROL SCHEMATIC		<b>SIZE</b> C		<b>CODE IDENT NO</b> 210439	
<b>FINISH</b>		<b>MATL</b>		<b>DO NOT SCALE DWG</b> SCALE: NONE		<b>SHEET 1 OF 3</b>	

EDC-041-B-81

4

3

2

1

TM-50 PC BA



# STEPPER MOTOR CONTROL

REVISIONS					
REV	DESCRIPTION	DATE	DR	CHK	APPR
	SEE SHEET 1				

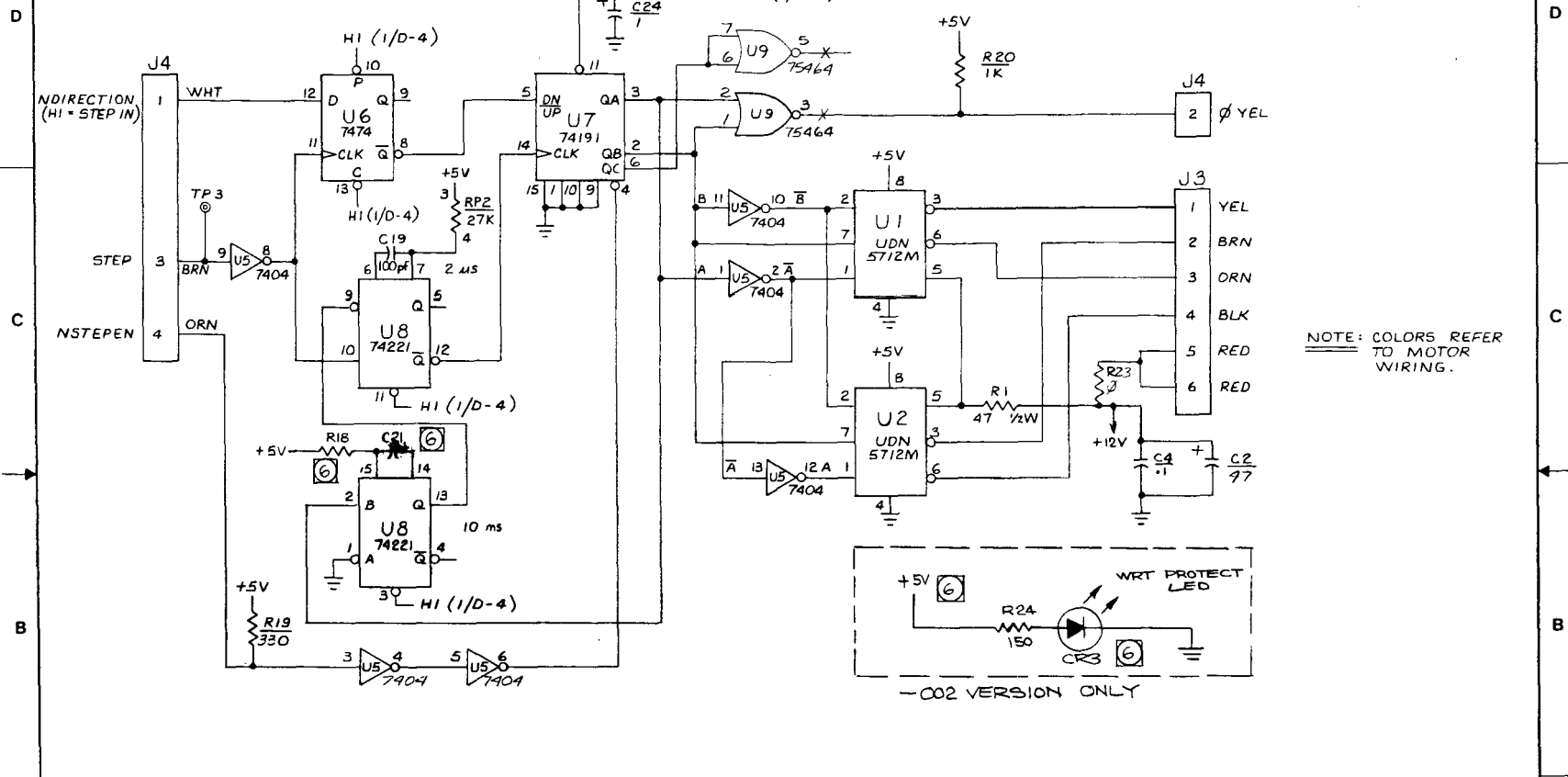

NOTE: COLORS REFER TO MOTOR WIRING.

TWO PHASES		
	(CW) STEP OUT	(CCW) STEP IN
Ø 1 ON	YEL BLK	YEL BRN
Ø 2 ON	ORN BLK	ORN BRN
Ø 3 ON	ORN BRN	ORN BLK
Ø 4 ON	YEL BRN	YEL BLK

SINGLE PHASE	
(CW) STEP OUT	(CCW) STEP IN
YEL	YEL
BLK	BRN
ORN	ORN
BRN	BLK

NOTES. UNLESS OTHERWISE SPECIFIED

SIGNATURES		DATE
DR		
CHK		
DES		
ENGR		
PROJ ENGR		
FINISH	MATL.	

<b>Tandon</b> CORPORATION		
TITLE		
MODEL TM-50 MOTOR CONTROL SCHEMATIC		
SIZE	CODE IDENT NO	DWG NO
C		210439
SCALE	DO NOT SCALE DWG	SHEET 3 OF 3
		REV H

⑥ TABLE I

VERSION	VERSION CHARACTERISTIC	CR3	R24	C21	R18	C16
-001	STANDARD	OMIT	OMIT	1UF	14.3K 1%	OMIT
-002	W/WRT PROTECT LED	USE	USE	1UF	14.3K 1%	OMIT
-003	FAST SEEK STEPPER MOTOR	USE	USE	.47UF	11.0K 1%	OMIT
-004	W/WRT PROTECT LED/ACCESS MATRIX	USE	USE	1UF	14.3K 1%	.47UF

REVISIONS						
REV	DESCRIPTION	DATE	DR	CHK	APPR	
E	REVISED PER EO 13094	1/24/83	HG	WRL	WRL	
F	REVISED PER EO 13195 B	2/17/83	E.A.			
G	REVISED PER EO 13206	3/14/83	HG			
H	REVISED PER EO 13386	7/26/83	JK			
J	PRODUCTION RELEASE EO 40480	1/14/84	JK	Jpr	JK	

I.C. TABLE

U1	UDN5712M
U2	UDN5712M
U3	LM2917
U4	7406
U5	7404
U6	7474
U7	74191
U8	74221
U9	75464
U10	LM555

SPARE GATES

I.C.	QTY
U6	1

LAST USED

U10	CR3	R24
Q2	C24	TP3

PIN LIST

CONN NAME	# OF PINS	USE
J1	4	SPINDLE MOTOR
J2	4	POWER
J3	6	STEPPER
J4	6	CONTROL
J5	2	DISKETTE LOADED

⑥ FOR PART NUMBER, VALUE & USAGE OF COMPONENTS AFFECTED BY VERSION NUMBER, SEE TABLE I

5. C12 USED FOR TEMP COMP.
4. ALL DIODES ARE IN 4446
3. CAPACITORS ARE IN  $\mu$ F,  $\pm$ 20%
2. 1% RESISTORS  $\frac{1}{8}$  W
1. ALL RESISTORS ARE IN OHMS,  $\frac{1}{4}$  W, 5%

NOTES: UNLESS OTHERWISE SPECIFIED

<small>THE INFORMATION CONTAINED HEREON IS THE PROPERTY OF TANDON CORPORATION. NO PORTION OF THIS DATA SHALL BE RELEASED OUTSIDE OF THE FACILITY OR FOR USE IN PROCUREMENT OR MANUFACTURING WITHOUT SPECIFIC WRITTEN PERMISSION FROM TANDON CORPORATION.</small>		<b>SIGNATURES</b> DR: <i>H. Gabel</i> CHG: <i>[Signature]</i> ENG: <i>[Signature]</i> PROJ ENGR:		<b>DATE</b> 1/25/83 1/25/83 2/1/83	<b>Tandon CORPORATION</b>	
<small>UNLESS OTHERWISE SPECIFIED DIMENSIONS ARE IN INCHES</small>		<small>TOLERANCES</small> .XX ± .005 .XX ± .01 .X ± .01 .X ± .01 BREAK ALL SHARP CORNERS APPROX .010		<b>TITLE</b> MODEL TM-50 MOTOR CONTROL SCHEMATIC		
<b>FINISH:</b>		<b>MATL:</b>		SIZE: <b>C</b> SCALE: NONE	CODE IDENT NO: 210439 DWG NO: 210439	REV: <b>J</b> SHEET 1 OF 3

# SPINDLE MOTOR CONTROL

REVISIONS					
REV	DESCRIPTION	DATE	DR	CHK	APPR
	SEE SHEET 1				

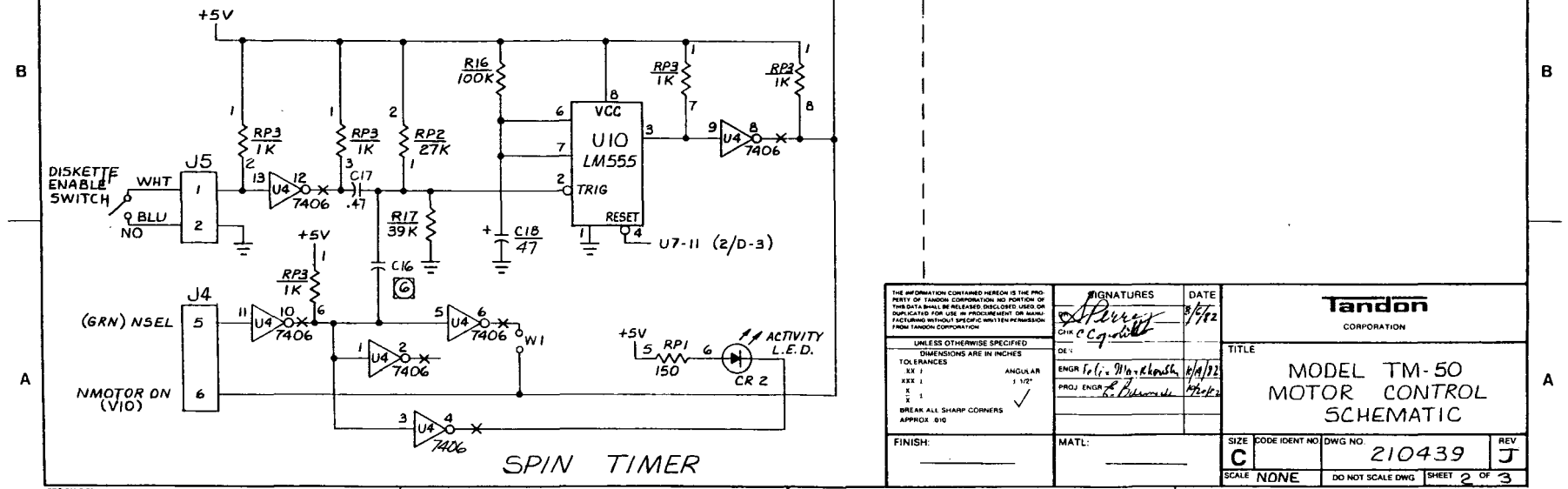
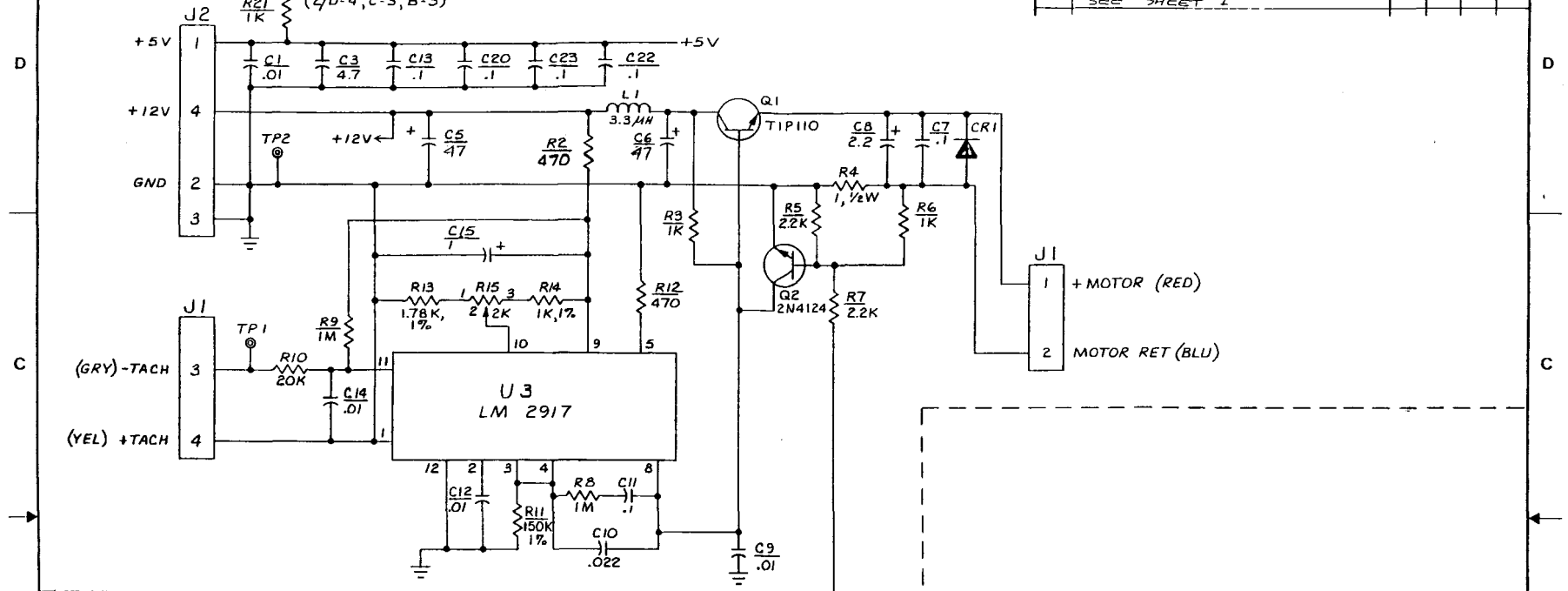

THE INFORMATION CONTAINED HEREON IS THE PROPERTY OF TANDON CORPORATION. NO PORTION OF THIS DATA SHALL BE REPRODUCED, COPIED, OR Duplicated FOR USE IN PROCUREMENT OR MANUFACTURING WITHOUT SPECIFIC WRITTEN PERMISSION FROM TANDON CORPORATION.		<b>Tandon</b> CORPORATION	
UNLESS OTHERWISE SPECIFIED: DIMENSIONS ARE IN INCHES TOLERANCES: XX 1 ANGLUAR 1/2° XXX 1 X X BREAK ALL SHARP CORNERS APPROX. 0.10		TITLE <h2 style="text-align: center;">MODEL TM-50 MOTOR CONTROL SCHEMATIC</h2>	
SIGNATURES DE: <i>[Signature]</i> CHK: <i>[Signature]</i>		DATE 8/4/82	
FINISH: _____		MATL: _____	
SIZE: <b>C</b>		CODE IDENT NO: _____	
SCALE: NONE		DWG NO: <b>210439</b>	
DO NOT SCALE DWG		REV: <b>J</b>	
SHEET 2 OF 3		SHEET 2 OF 3	

# STEPPER MOTOR CONTROL

REVISIONS					
REV	DESCRIPTION	DATE	DR	CHK	APPR
	SEE SHEET 1				

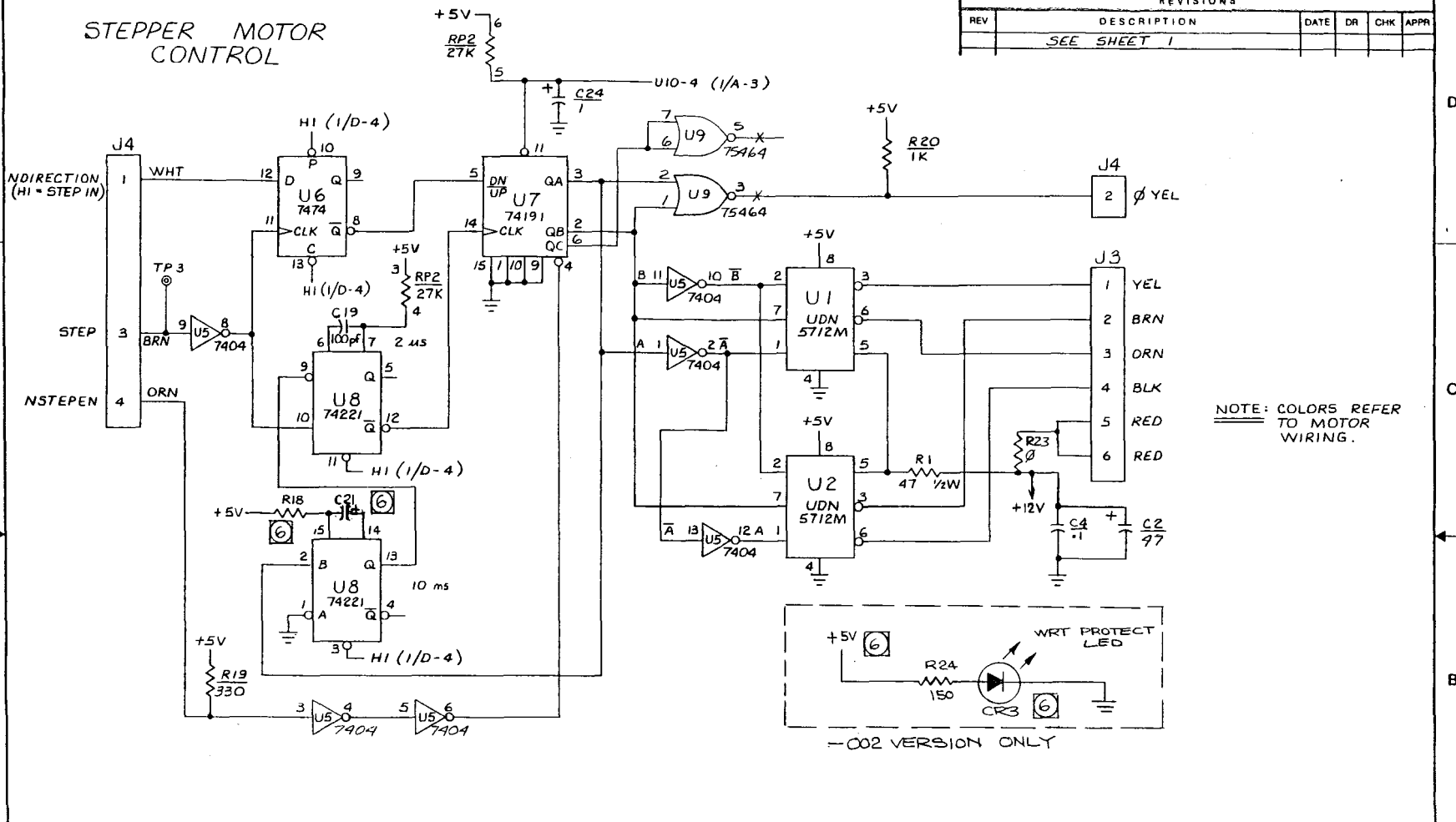

NOTE: COLORS REFER TO MOTOR WIRING.

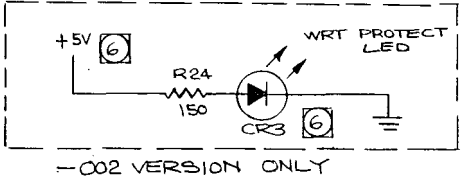

TWO PHASES		
	(CW) STEP OUT	(CCW) STEP IN
Ø 1 ON	YEL BLK	YEL BRN
Ø 2 ON	ORN BLK	ORN BRN
Ø 3 ON	ORN BRN	ORN BLK
Ø 4 ON	YEL BRN	YEL BLK

SINGLE PHASE		
	(CW) STEP OUT	(CCW) STEP IN
	YEL	YEL
	BLK	BRN
	ORN	ORN
	BRN	BLK

NOTES: UNLESS OTHERWISE SPECIFIED

SIGNATURES	DATE			
		DR	CHK	ENGR

<b>Tandon</b> CORPORATION	
TITLE <b>MODEL TM-50 MOTOR CONTROL SCHEMATIC</b>	
SIZE <b>C</b>	CODE IDENT NO <b>210439</b>
SCALE <b>NONE</b>	DWG NO <b>210439</b>
	REV <b>J</b>
	SHEET <b>3</b> OF <b>3</b>

EOC-041-8-81



I. C. TABLE	
U1	NE592
U2	7406
U3	MPQ2907
U4	CA3146
U5	7406
U6	7400
U7	7404
U8	7400
U9	LM393
U10	75463
U11	NE592
U12	LM311
U13	7486
U14	7474
U15	74221
U16	74123
U17	7414
U18	7438
U19	SHUNT

\* 8 PIN DIP

PIN LIST		
CONN. NAME	# OF PINS	USE
J6	10	HEAD
J7	4	POWER
J8	34	I/O
J9	4	TK OO
J10	6	MODR CNTL. INT. FACE
J11	2	WPRT
J12	4	INDEX

SPARE GATES	
I. C.	QTY.
U2	1
U4	1
U5	1
U13	1

LAST USED	
U19	C37
R39	RP11
TP13	L3
CR20	W9

APPLICABLE P.C.B. REV. LEVEL	
APPLICABLE ASSY. REV. LEVEL	

REVISIONS					
REV	DESCRIPTION	DATE	DR	CHK	APPR
A	PRELIMINARY RELEASE	7/22	JP		
B	PRE-PROD. RELEASE PER E.O. 12811	7/22	JP		
C	PRE-PROD. RELEASE PER E.O. 12810	7/22	JP		
D	REV PER EO 12950	7/22	JP		
E	REV PER EO 12970	7/22	JP		
F	REV PER EO 13048	7/22	JP		
G	REV PER EO 13238	7/22	JP		
H	REV PER EO 13254	7/22	JP		
J	REV PER EO 13301	7/22	JP		
K	REV PER EO 40356	7/22	JP		
L	INCOMP. EO. 40381	7/22	JP		
M	INCOMP. EO. 40389	7/22	JP		

- COLORS REFER TO HARNESS WIRING.
- ALL DIODES ARE 1N4446.
- CAPACITORS ARE IN MF, ±10%.
- ALL 1% RESISTORS ARE 1/8 W.
- ALL RESISTORS ARE IN OHMS, 1/4 W, 5%.

**1** ALL ODD NUMBERED PINS ARE CONNECTED TO GROUND.

NOTES: UNLESS OTHERWISE SPECIFIED

<small>THE INFORMATION CONTAINED HEREON IS THE PROPERTY OF TANDON CORPORATION FOR NO PORTION OF THIS DRAWING SHALL BE RELEASED, DISCLOSED, REPRODUCED OR COPIED FOR USE IN CONNECTION WITH ANY PROJECTS WITHOUT SPECIFIC WRITTEN PERMISSION FROM TANDON CORPORATION.</small>		SIGNATURES <i>[Signature]</i> 7/22 <i>[Signature]</i> 7/22 <i>[Signature]</i> 7/22		DATE 7/22	<b>Tandon</b> CORPORATION
UNLESS OTHERWISE SPECIFIED DIMENSIONS ARE IN INCHES TOLERANCES .XX =                      ANGULAR .XX =                      ± 1/2" .X =                        ✓ BREAK ALL SHARP CORNERS APPROX .010		DES ENGR PROJ ENGR FINISH MATL		TITLE <b>MODEL TM-50          READ / WRITE BOARD          SCHEMATIC          DOUBLE SIDED</b>	
SIZE CODE IDENT NO DWG NO <b>C</b> 210441		REV <b>M</b>		SCALE                      DO NOT SCALE DWG SHEET 1 OF 4	

REVISIONS					
REV	DESCRIPTION	DATE	DR	CHK	APPR
	SEE SHT 1				

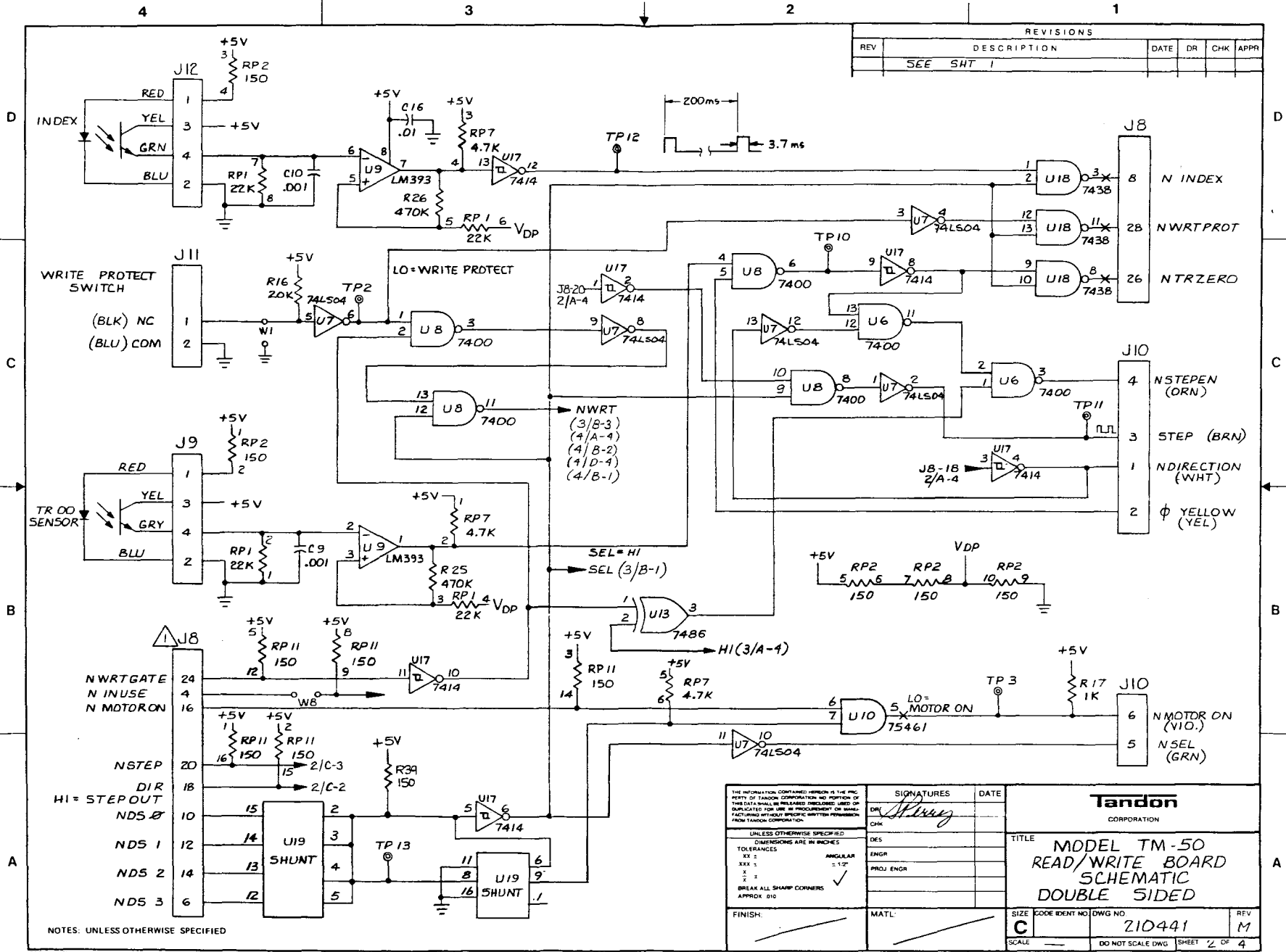

NOTES: UNLESS OTHERWISE SPECIFIED

SIGNATURES		DATE
DR	<i>[Signature]</i>	
CHK		
DES		
ENGR		
PROJ ENGR		

<b>Tandon</b> CORPORATION		
TITLE <b>MODEL TM-50 READ/WRITE BOARD SCHEMATIC DOUBLE SIDED</b>		
SIZE <b>C</b>	CODE IDENT NO. <b>210441</b>	DWG NO. <b>M</b>
SCALE	DO NOT SCALE DWG	SHEET 2 OF 4

REVISIONS				
REV	DESCRIPTION	DATE	DR	CHK APPR
1	SEE SH1 1			

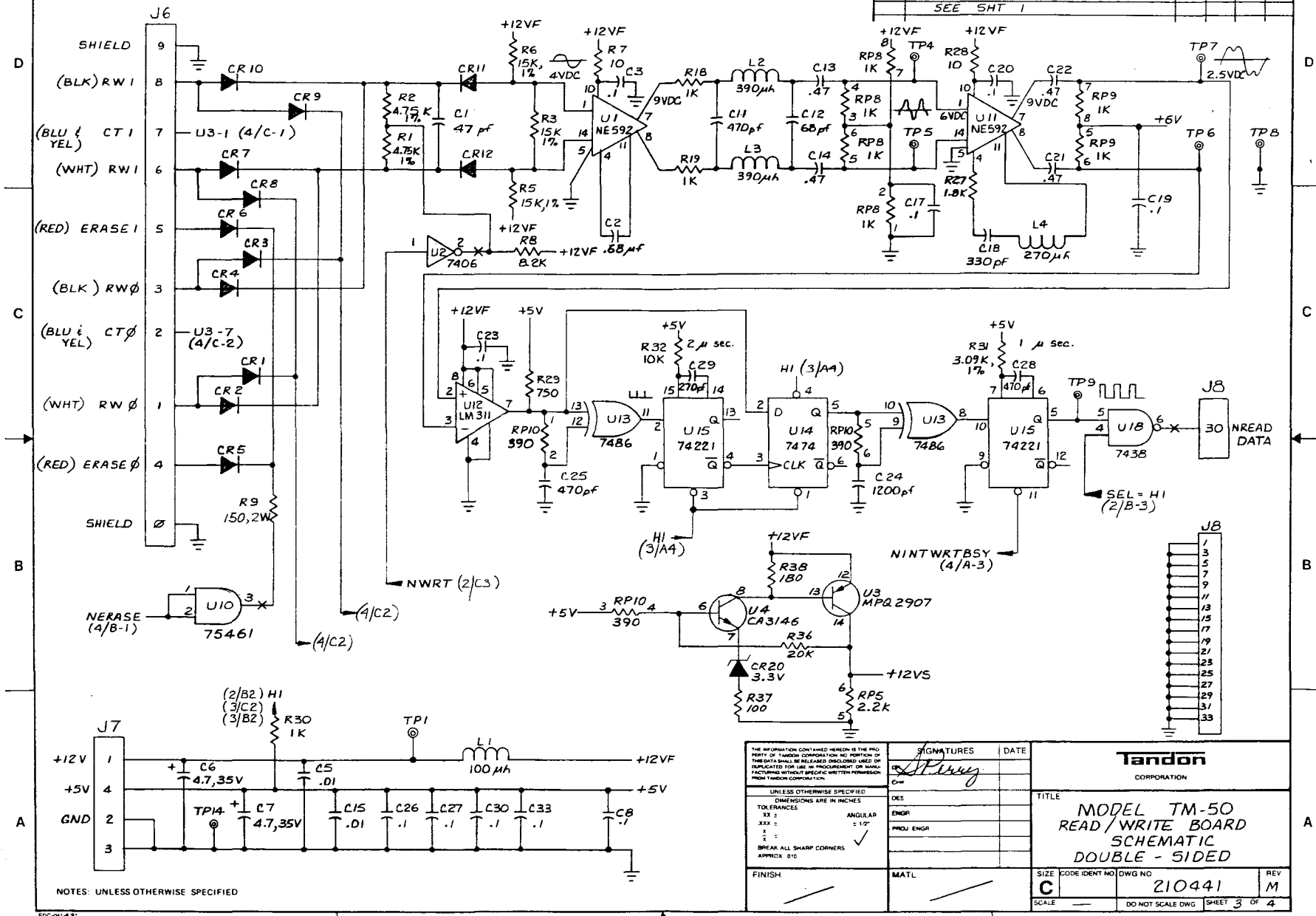

NOTES: UNLESS OTHERWISE SPECIFIED

<small>THE INFORMATION CONTAINED HEREON IS THE PROPERTY OF TANDON CORPORATION. NO PORTION OF THIS DATA SHALL BE RELEASED OR REPRODUCED OR USED FOR ANY PURPOSE WITHOUT SPECIFIC WRITTEN PERMISSION FROM TANDON CORPORATION.</small>		<b>SIGNATURES</b> DES: <i>[Signature]</i> ENG: PROJ ENGR: DATE: TITLE:	
<small>UNLESS OTHERWISE SPECIFIED:          DIMENSIONS ARE IN INCHES          TOLERANCES: XX ± .01          XXX ± .005          ANGULAR ± 1°          BREAK ALL SHARP CORNERS          APPROX. 0.10</small>		<b>Tandon CORPORATION</b>  <b>MODEL TM-50          READ/WRITE BOARD          SCHEMATIC          DOUBLE-SIDED</b>	
FINISH: /	MATL: /	SIZE: <b>C</b> SCALE: /	ECODE IDENT NO: DWG NO: <b>210441</b> REV: <b>M</b> DO NOT SCALE DWG SHEET <b>3</b> OF <b>4</b>

EDC-014-B

REVISIONS					
REV	DESCRIPTION	DATE	DR	CHK	APPR
1	SEE 5HT 1				

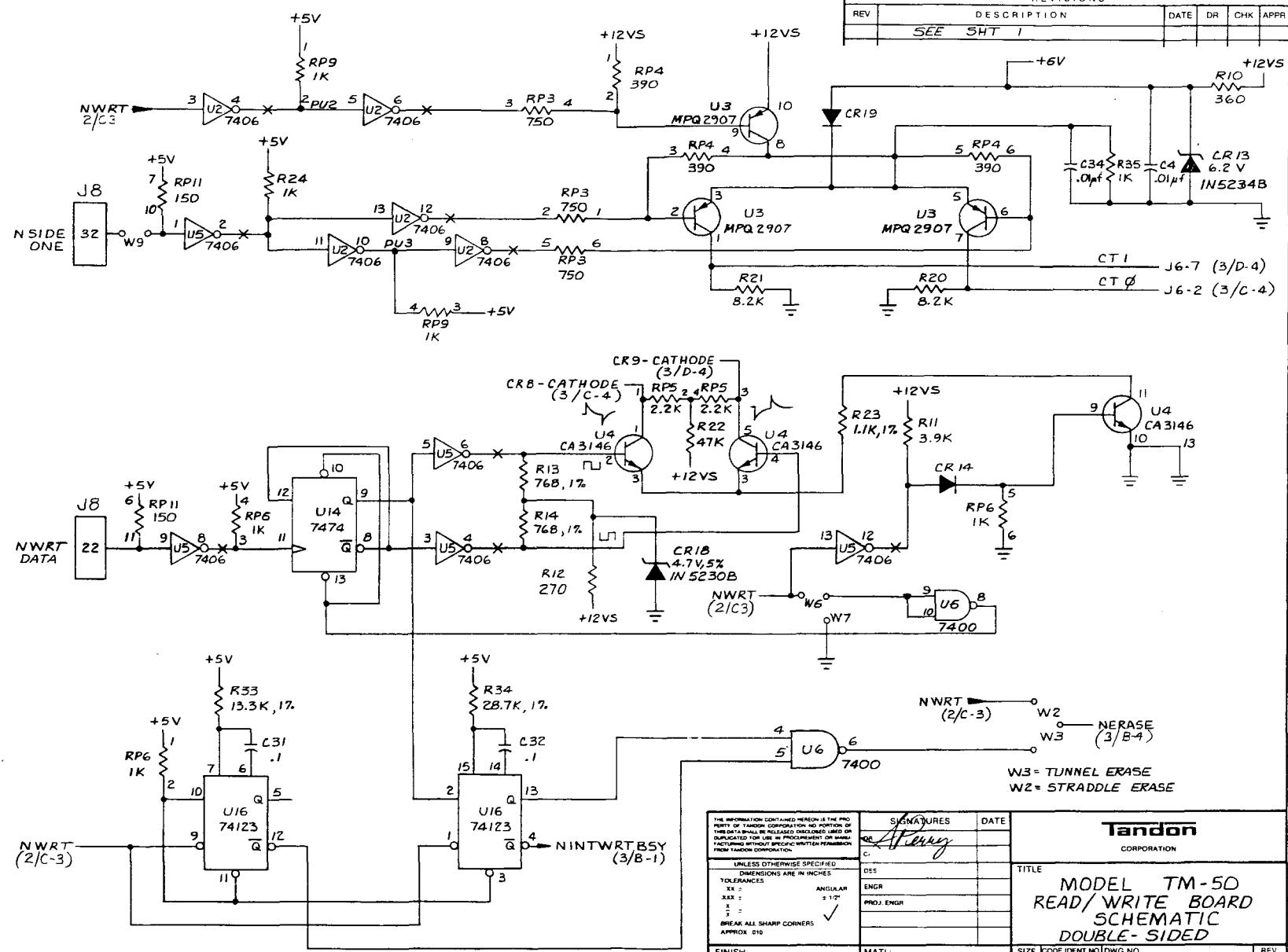

NOTES: UNLESS OTHERWISE SPECIFIED

<small>THE INFORMATION CONTAINED HEREON IS THE PROPERTY OF TANDON CORPORATION AND NO PORTION THEREOF SHALL BE RELEASED, REPRODUCED OR DUPLICATED FOR USE IN PROCUREMENT OR MANUFACTURING WITHOUT SPECIFIC WRITTEN PERMISSION FROM TANDON CORPORATION.</small>		<b>SIGNATURES</b> DR: <i>Attery</i> DES: _____ ENGR: _____ PROJ. ENGR: _____		<b>DATE</b> _____
<small>UNLESS OTHERWISE SPECIFIED DIMENSIONS ARE IN INCHES TOLERANCES</small>		<b>Tandon CORPORATION</b>		<b>TITLE</b> MODEL TM-50 READ/WRITE BOARD SCHEMATIC DOUBLE-SIDED
<small>XX ±</small> <small>XXX ±</small> <small>±</small> <small>BREAK ALL SHARP CORNERS APPROX. 0.01</small>	<small>ANGULAR ± 1/2°</small> <input checked="" type="checkbox"/>	<small>FINISH:</small> _____	<small>MATL:</small> _____	<b>SIZE</b> <b>C</b>
<small>CODE IDENT NO</small>		<small>DWG NO</small> <b>210441</b>	<small>REV</small> <b>M</b>	<small>DO NOT SCALE DWG</small> SHEET 4 OF 4

EDC-011-48

I. C. TABLE	
U1	NE592
U2	7406
U3	MPQ2907
U4	CA3146
U5	7406
U6	7400
U7	7404
U8	7400
U9	LM393
U10	75463
U11	NE592
U12	LM311
U13	7486
U14	7474
U15	74221
U16	74123
U17	7414
U18	7438
U19	SHUNT
* B PIN DIP	

PIN LIST		
CONN. NAME	# OF PINS	USE
J6	10	HEAD
J7	4	POWER
J8	34	I/O
J9	4	TK 00
J10	6	MOTOR CNTL INT. FACE
J11	2	WPRT
J12	4	INDEX

SPARE GATES	
I. C.	QTY.
U2	1
U4	1
U5	1
U13	1

LAST USED	
U19	C37
R39	RP11
TP13	L3
CR20	W9

APPLICABLE P.C.B REV. LEVEL	
APPLICABLE ASSY. REV. LEVEL	

REVISIONS					
REV	DESCRIPTION	DATE	DR	CHK	APPR
A	PRELIMINARY RELEASE	7/28	JP		
B	PRE-PROD. RELEASE PER E.O. 12711	7/28	JT		
C	PRE-PROD. RELEASE PER E.O. 12810	7/28	JT		
D	REV PER EO 12950	12/28	JG		
E	REV PER EO 12970	12/28	JG		
F	REV PER EO 13048	7/28	JG		
G	REV PER EO 13238	7/28	JG		
H	REV PER EO 13254	3/10/83	HG		
J	REV PER EO 13301	7/14/83	HG		
K	REV PER EO 40356	7/26/83	JG		
L	INCORP EO 40381	7/28/83	JM		
M	INCORP EO 40389	7/28/83	JM		
N	PRODUCTION RELEASE	12/14/83	JT		

- COLORS REFER TO HARNESS WIRING.
- ALL DIODES ARE 1N4446.
- CAPACITORS ARE IN MF, ±10%.
- ALL 1% RESISTORS ARE 1/8 W.
- ALL RESISTORS ARE IN OHMS, 1/4 W, 5%.

⚠ ALL ODD NUMBERED PINS ARE CONNECTED TO GROUND.

NOTES: UNLESS OTHERWISE SPECIFIED

<small>THE INFORMATION CONTAINED HEREON IS THE PROPERTY OF TANDON CORPORATION NO PORTION OF THIS DATA SHALL BE RELEASED, REPRODUCED OR DUPLICATED FOR USE IN PROCUREMENT OR MANUFACTURING WITHOUT SPECIFIC WRITTEN PERMISSION FROM TANDON CORPORATION</small>		SIGNATURES <i>[Signature]</i> <small>(CHK)</small>		DATE 7/28 7/28/83	<b>Tandon</b> CORPORATION
UNLESS OTHERWISE SPECIFIED DIMENSIONS ARE IN INCHES TOLERANCES XX ± .001 XXX ± .002 X ± .005 X ± .010 BREAK ALL SHARP CORNERS APPROX .010		DES ENGR PROJ ENGR		TITLE MODEL TM-50 READ / WRITE BOARD SCHEMATIC DOUBLE SIDED	
FINISH		MATL		SIZE <b>C</b>	CODE IDENT NO 210441
				DWG NO 210441	REV <b>N</b>
				SCALE	DO NOT SCALE DWG SHEET 1 OF 4

REVISIONS				
REV	DESCRIPTION	DATE	DR	CHK
SEE SHT 1				

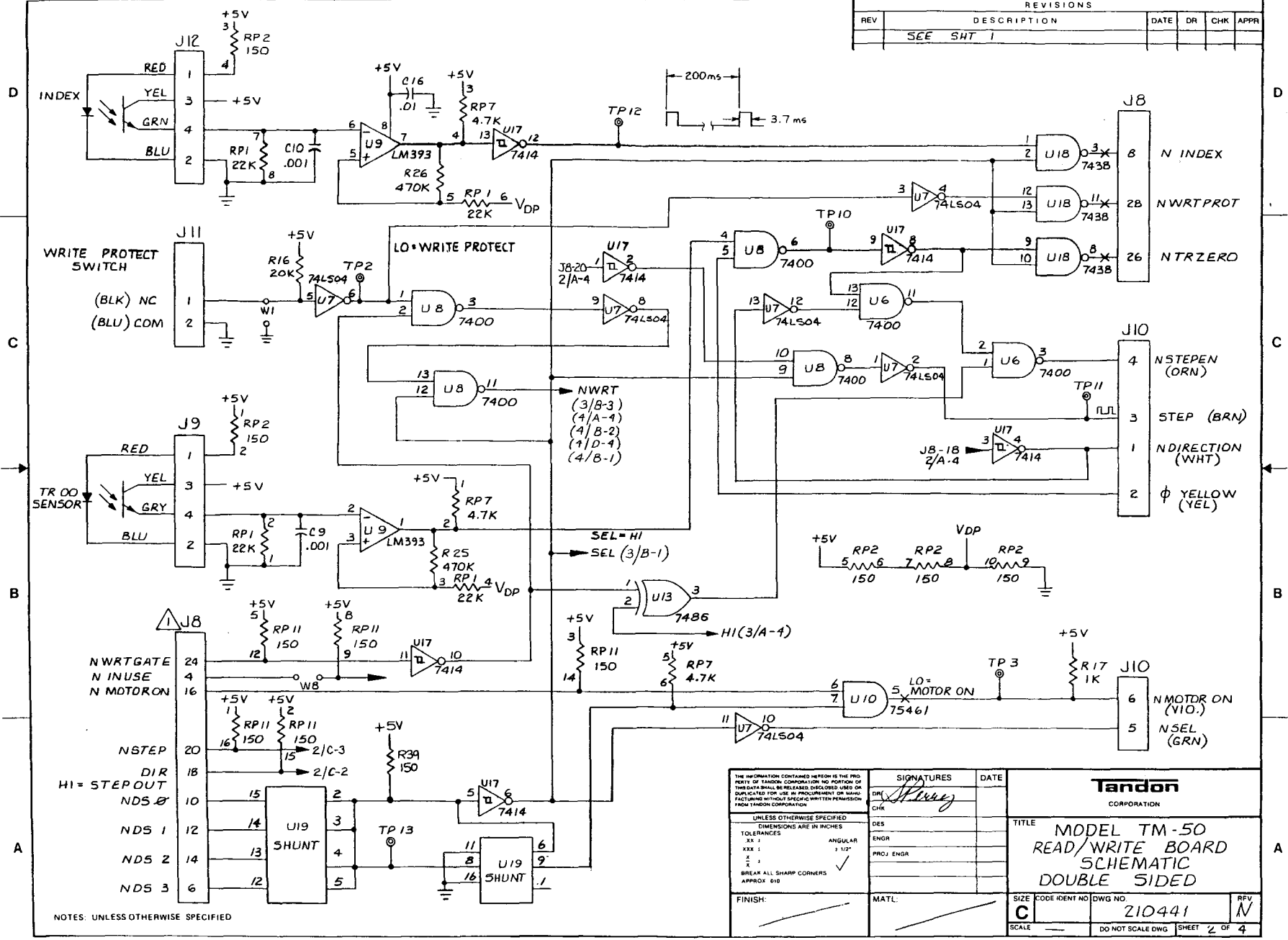

<small>THE INFORMATION CONTAINED HEREON IS THE PROPERTY OF TANDON CORPORATION NO PORTION OF THIS DATA SHALL BE RELEASED, DISCLOSED, USED OR DUPLICATED FOR USE IN PROCUREMENT OR MANUFACTURING WITHOUT SPECIFIC WRITTEN PERMISSION FROM TANDON CORPORATION</small>		<b>SIGNATURES</b> DR: <i>[Signature]</i> ENGR: PROJ ENGR:		<b>DATE</b>   
<small>UNLESS OTHERWISE SPECIFIED</small>		<b>Tandon CORPORATION</b>		<b>TITLE</b> MODEL TM-50 READ/WRITE BOARD SCHEMATIC DOUBLE SIDED
<small>DIMENSIONS ARE IN INCHES</small>		<small>DES</small> <small>ENGR</small> <small>PROJ ENGR</small>		<b>SIZE</b> <b>C</b>
<small>FINISH:</small>		<small>MATL:</small>		<b>CODE IDENT NO</b> 210441
<small>DO NOT SCALE DWG</small>		<small>SHEET 2 OF 4</small>		<b>REV</b> N