



A **BOVER** COMPANY

Automation
Robohand *FERGUSON*
CAMCO

SERVICE MANUAL OVERLOAD CLUTCHES

FOR INDEX DRIVES

WARNING

This is a controlled document. It is your responsibility to deliver this information to the end user of the CAMCO or FERGUSON product. Failure to deliver this could result in your liability for injury to the user or damage to the machine. For copies of this manual, call your Customer Service Representative at 800-645-5207

INSTALLATION, OPERATION AND MAINTENANCE INSTRUCTIONS

SAFETY INSTRUCTIONS

1. Read your Overload Clutch Installation-Operation Instructions thoroughly before operating the unit, for your safety and the protection of your unit.
2. CAMCO Overload Clutches are designed to protect the Index Drive *only* and will not protect against bodily injury.
3. Double check to be sure the power is off and cannot be turned on while working on the equipment.
4. Use extreme caution with jammed or unbalanced loads, which when cleared may set the machine in motion.
5. Keep all objects such as hands, clothing, tools away from rotating or moving parts.
6. Use safety glasses or equivalent to protect your eyes.

7. Dowel pins and mounting screws must not protrude from the drive plate or driven member as the clutch could become a solid coupling.
8. High humidity, contaminants, or wash down applications may cause rust within the clutch, resulting in operational failure. Lubricate every six months or more frequently as the application requires.
9. The CAMCO clutch is not a "FAIL SAFE" device and cannot be used on "overhauling" or "holding" load applications.

The above list includes major safety points to be observed, but should not be considered as limiting in safety precautions to be followed.

OPERATING PRINCIPLE

CAMCO Overload Clutches are designed for mounting on the output member of the CAMCO Index Drive. An Index Drive is essentially a variable ratio speed reducer. Each index provides an incremental output to input torque ratio, which may range from 1:1 in the center of the motion, to as high as 1000:1 in the beginning or end of the motion. As output torque equals input torque times the ratio, a clutch mounted on the input side provides no protection at the beginning or end of the motion.

CAMCO Overload Clutches provide zero backlash, high rigidity, low inertia and are specifically designed to be used in conjunction with CAMCO Index Drives.

Power is transmitted from the Index Drive through the body of the CAMCO Overload Clutch. The body contains spring loaded tapered plungers that engage in mating tapered seats in the drive plate. (See Fig. 1.) Torque settings are determined by the pressure the calibrated springs "seat" the plungers.

When an overload occurs, which exceeds the torque setting of the clutch, the breakaway friction between the tapered plunger and the tapered seat, forces the plungers outward from their seats. The movement of the plungers elevates the detector plate, actuating the limit switch. (See Fig. 2.)

The CAMCO Overload Clutch always resets in its original position, making it an excellent choice on applications that must remain registered or timed.

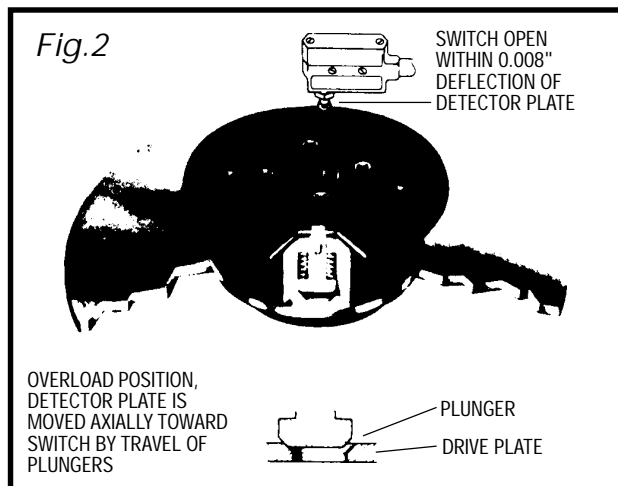
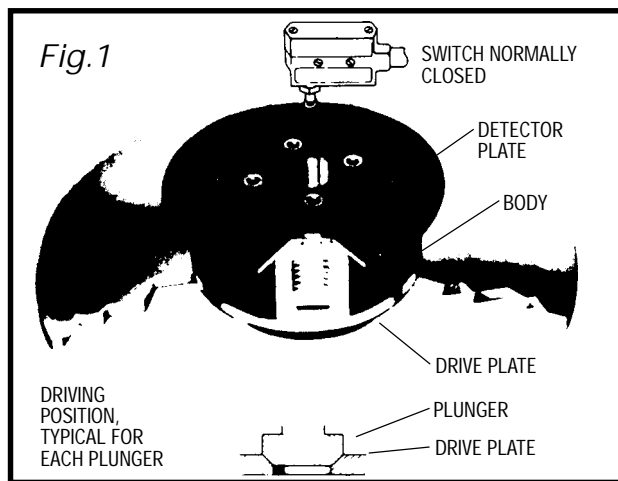

CLUTCH TYPES

CAMCO clutches are designed to meet specific application requirements. They are available in five basic designs.

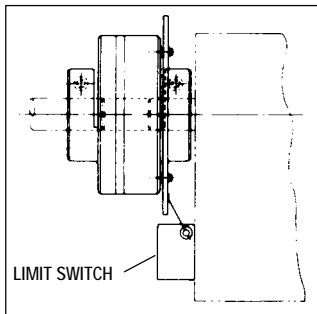
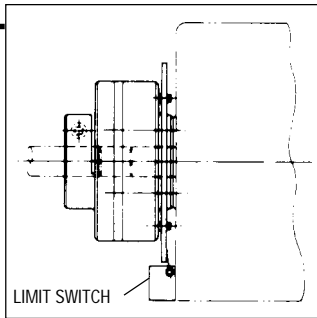
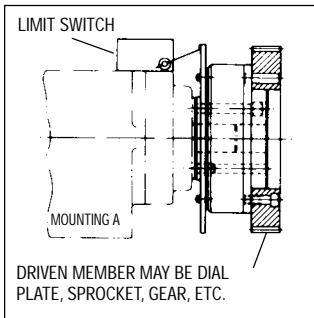
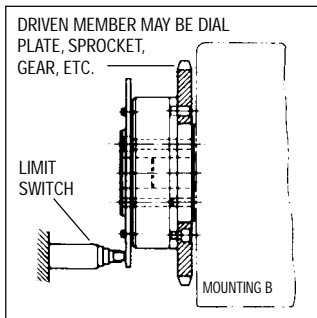
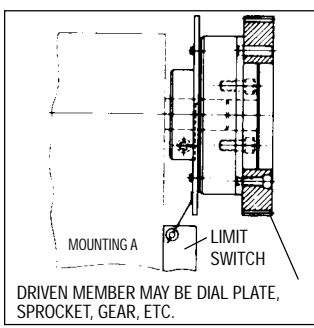
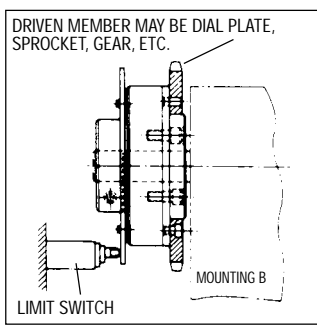
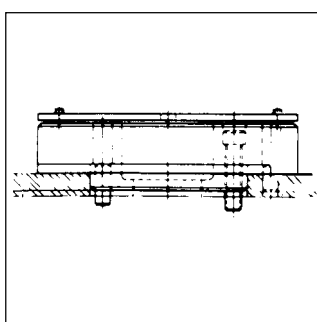
<p>.39C 2.3C 6.0C 11C 25C 41C</p>	<p>TYPE C</p> <ul style="list-style-type: none"> • Clamped Hub • Clamped Body • Shrink Disc <p>A clutch coupling which can be mounted on Index Drives without output flanges. They provide a positive, rigid connection between two shafts.</p>		
<p>.39FC 2.3FC 6.0FC 11FC 25FC 41FC</p>	<p>TYPE FC</p> <ul style="list-style-type: none"> • Flange Mounted Body • Clamped Hub • Shrink Disc <p>These clutch couplings flange mount to the output shaft of the Index Drive and provide a keyed-clamped hub connection to the driven shaft.</p>		
<p>.39F 2.3F 6.0F 11F 25F 41F 140F</p>	<p>TYPE F</p> <ul style="list-style-type: none"> • Shaft Mounted Body <p>The type F Clutch flange mounts to the output shaft of the Index Drive and provides a mounting surface for a dial plate, sprocket, gear, etc., resulting in a rigid, compact and accurate connection to the driven member.</p>		
<p>.39S 2.3S 6.0S 11S 25S 41S</p>	<p>TYPE S</p> <ul style="list-style-type: none"> • Shaft Mounted • Clamped Body • Shrink Disc <p>The combination of a key and clamped hub construction provides rigid and backlash-free shaft connections. The Type S clutch is designed to mount on Index Drives without flanges.</p>		
<p>2.8D 4.0D 7.8D 18D 31D 32D 61D 130D</p>	<p>TYPE D</p> <ul style="list-style-type: none"> • Flange Mounted <p>These units are designed to mount on CAMCO Index Drives featuring large output mounting surfaces. The dial plate rests directly on the Index Drive output flange, providing the ultimate in stability and accuracy.</p>		

INSTALLATION AND REMOVAL INSTRUCTIONS FOR SHRINK DISCS

Shrink Discs are supplied ready for installation. However, prior to tightening of locking screws it is necessary to remove wooden spacers located between outer collars, which are used during shipment of Shrink Discs.

INSTALLATION

Important: Never tighten locking screws before shaft installation, since inner ring of Shrink Discs as well as hub can be permanently contracted even at relatively low tightening torques.

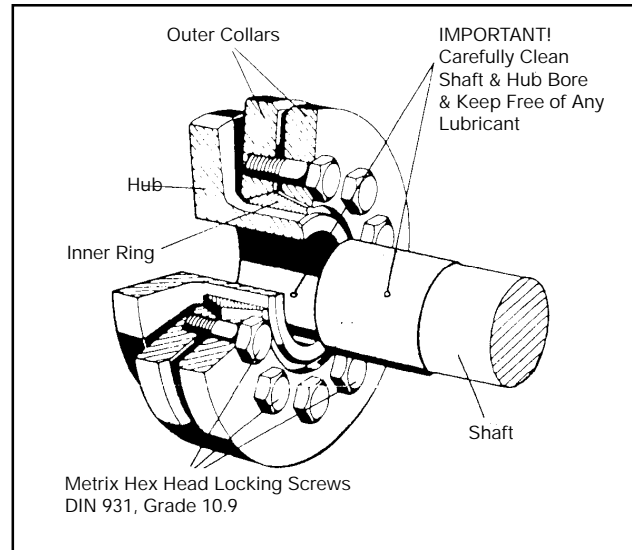

- 1 Clean hub O.D. and Shrink Disc bore and lightly lubricate hub O.D. before assembly of Shrink Disc on hub.
- 2 Carefully clean shaft and hub bore from *any lubricant* prior to mounting hub onto shaft. THIS STEP IS VERY IMPORTANT, since it will greatly affect the torque transmitting capability of a Shrink Disc connection.
- 3 After checking correct position of Shrink Disc and hub, handtighten 3 or 4 equally spaced locking screws and make sure that outer collars of Shrink Disc are in a parallel position. Afterwards handtighten rest of locking screws.
- 4 Use torque wrench and equally tighten all screws one after another in a clock or counterclockwise sequence by approx. 1/4 turns (even if initially some screws will require a very low tightening torque) until specified tightening torque M_A is reached. **NOTE:** To compensate for bolt setting during installation, a 5% higher than specified tightening torque is recommended for final tightening round.
- 5 Reset torque wrench and make sure that no screw will turn at specified tightening torque M_A .

NOTE: It is not necessary to check tightening torque again after installation is completed or equipment has been in operation.

REMOVAL

1. Loosen locking screws in several stages by using approx. 1/2 turns, following either a clock or counterclockwise sequence till Shrink Disc can be moved on hub. DO NOT remove locking screws completely.

2. Make sure any rust buildup in front of hub is removed before hub is pulled from shaft.

RE-INSTALLATION OF SHRINK DISC

In relatively clean operating conditions, Shrink Discs can be re-used without prior cleaning. Severe conditions, however, require thorough cleaning and re-lubrication with the following or similar lubricants:

Tapers of inner rings and outer collar bores: Molykote 3321 R-spray or Molykote G RAPID-spray or paste

Screwthreads and head contact area: Multipurpose grease like Molykote BR-2

Damaged O-rings should be replaced.

LOCKING SCREW-TIGHTENING TORQUES "M _A "									
screw size	M5	M6	M8	M10	M12	M16	M20	M24	M27
 mm	8	10	13	17	19	24	30	36	41
M _A [Nm]	5	12	30	59	100	250	490	840	1250
M _A [ft.-lbs]	3.6	8.7	22	44	74	185	362	620	922

SHRINK DISC COUPLINGS

FOR RIGID SHAFT CONNECTIONS- TRANSMIT TORQUES & BENDING MOMENTS- PERMIT AXIAL & ANGULAR TIMING

SHRINK DISC (PREFERABLY USE UNITS WITH INTEGRATED HUB STOP) REFER TO SHRINK DISC SPECIFICATION TABLE FOR SELECTION OF SHRINK DISC TO MEET YOUR TORQUE & SHAFT SIZE REQUIREMENTS. CONSULT WITH US IF A BENDING MOMENT HIGHER THAN 25% OF RATED TORQUE HAS TO BE TRANSMITTED.

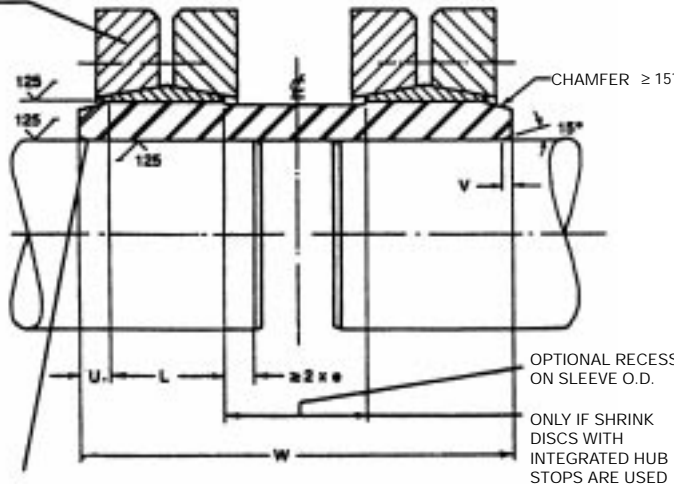

COUPLING SLEEVE CAN BE SUPPLIED BY BIKON CORP. USE MATERIAL WITH A YIELD POINT OF AT LEAST 36000 PSI FOR LIGHT DUTY APPLICATIONS, BUT AISE 1045 (OR BETTER) FOR MEDIUM DUTY APPLICATIONS.

SEE SHRINK DISC SPECIFICATION TABLE FOR DIMENSIONS "L" & "e"

RECOMMENDED SLEEVE DIMENSIONS FOR SHRINK DISC COUPLINGS USING SERIES 01 & SERIES 03 SHRINK DISC SIZE 140 & LARGER

SHRINK DISC SIZE	U	V	SERIES 01	SERIES 03
140	5/8	1/8	8.00	9.00
145 thru 155	5/8	1/8	8.38	9.50
160 thru 175	7/8	1/8	9.00	10.50
180 thru 200	7/8	3/16	11.00	12.63
220	7/8	3/16	12.25	14.38
240	1	3/16	13.25	15.38
260	1	3/16	14.00	16.63
280	1-1/4	1/4	15.50	18.25
300	1-1/4	1/4	16.25	18.50
320	1-1/4	1/4	16.25	19.00
340	1-1/2	1/4	17.75	21.00
350 & 360	1-1/2	1/4	18.25	21.25
380 & 390	1-1/2	5/16	18.75	22.25
420	1-3/4	5/16	21.00	24.75
440 & 460	1-3/4	3/8	22.25	26.25
480 & 500	1-3/4	3/8	23.75	28.25

REQUIRED ASSEMBLIES (FIG. 3)	CLUTCH TYPE			
	C	FC	F	S
HUB	①	①		
FLANGE PLATE	Σ	Σ	Σ	Σ
DRIVE PLATE	Π	Π	Π	Π
BODY (S, C)	π			π
DETECTOR PLATE	∩	∩	∩	∩
BODY (F, FC)		⑥	⑥	
PLUNGERS	⑦	⑦	⑦	⑦
SPRINGS	Ω	Ω	Ω	Ω

TYPES C, FC AND F, S CLUTCHES

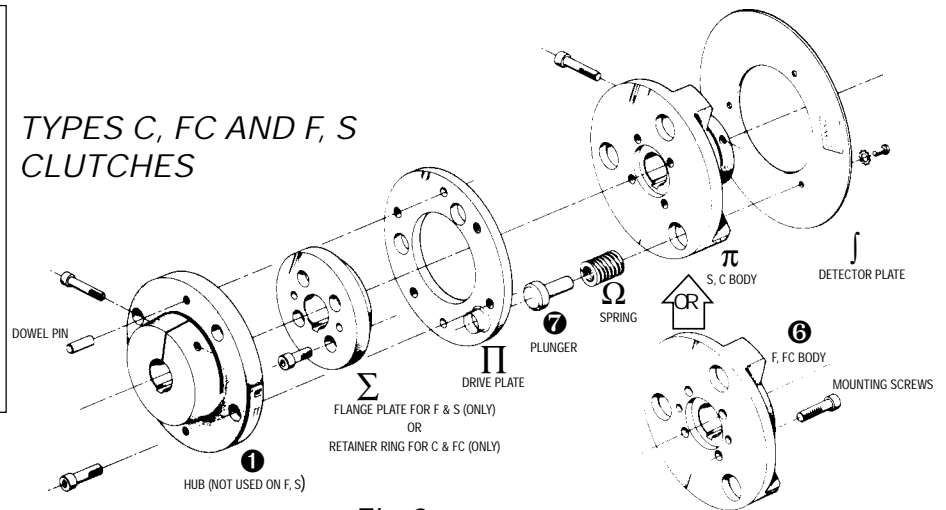

Fig.3

INSTALLATION INSTRUCTIONS TYPES C AND FC CLUTCH COUPLINGS

ASSEMBLY INSTRUCTIONS

See Fig. 3 for required assemblies

Important: To obtain maximum accuracy in positioning the DRIVEN MEMBER, the INDEX DRIVE "CAM SHAFT" must be in the EXACT CENTER OF DWELL position. See CAMCO drawing applicable to the Index Drive Model.

1. Insert PLUNGERS ⑦ into SPRINGS Ω and install the assemblies in the BODY pockets. Test for free movement of the plungers. Lightly lubricate the body pockets, springs

and plungers with Mobilgrease 77 or equivalent.

Caution: Do not overlubricate. Heavy lubrication may prevent clutch disengagement.

2. Install the FLANGE PLATE Σ into the DRIVE PLATE Π *Lightly* lubricate both sides of the DRIVE PLATE and the machined face of the BODY with Mobilgrease 77 or equivalent.

3. Align the PLUNGERS with the tapered seats in the DRIVE PLATE.
4. Type C Clutch COUPLING: Insert mounting screws through the FLANGE PLATE into the tapped holes in the BODY π . Alternately tighten the screws until the flange plate is seated on the BODY.
- 4A. Type FC Clutch COUPLING: Insert the mounting screws through the BODY Θ and FLANGE PLATE into the tapped holes in the INDEX DRIVE flange. Alternately tighten the screws until the FLANGE PLATE is seated on the BODY.
5. Assemble the DETECTOR PLATE Γ on the clutch BODY and secure both the DETECTOR PLATE and the PLUNGERS with the detector mounting screws.
6. Install the assembled clutch on the output shaft or flange of the INDEX DRIVE.
7. Press the dowel pins in the HUB $\textcircled{1}$ until they protrude approximately .125" beyond the machined face of the HUB.
8. Insert the HUB mounting screws through the HUB into the tapped holes in the DRIVE PLATE. Tighten the HUB mounting screws.
9. Drive the dowel pins flush with the HUB shoulder.

WARNING: Hub mounting screws and dowel pins must not protrude from the drive plate as they may lock against the adjacent surface, making the clutch inoperative.
10. Place driven shaft in HUB $\textcircled{1}$. The respective shafts should not protrude from the face of the HUB or the FLANGE PLATE. Tighten clamp screws.
11. Note: Shafts must be aligned within .003" TIR, and there must be an airgap between the DRIVE PLATE and CLUTCH BODY of .004" to .01". Check clearances with a shim or feeler gauge throughout the full diameter of the clutch.

Warning: Excessive misalignment will cause the coupling to lock.
12. Test for proper torque setting.

DISASSEMBLY INSTRUCTIONS (Types C and FC)

1. Remove HUB mounting screws and separate the HUB from the CLUTCH. (Resistance may be caused by the dowel pins.)
2. Type C Clutch: Remove output shaft clamp screws.
- 2A. Type FC Clutch: Remove mounting screws.
3. Remove the clutch from the index drive.
4. Type C Clutch: Remove mounting screws.

5. Place BODY with the PLUNGERS *face* down on a solid surface.
6. Remove DETECTOR MOUNTING screws which will release the PLUNGER assemblies.

Warning: The plunger assemblies are spring loaded and under tension. Bodily injury could result if the plunger assemblies are not retained against a solid surface.

INSTALLATION INSTRUCTIONS TYPES F AND S CLUTCHES

ASSEMBLY INSTRUCTIONS

See Fig. 3 for required assemblies

Important: To obtain maximum accuracy in positioning the DRIVEN MEMBER, the INDEX DRIVE "CAM SHAFT" must be in the EXACT CENTER OF DWELL position. See CAMCO drawing applicable to the Index Drive Model.

1. Insert PLUNGERS $\textcircled{7}$ into SPRINGS Ω and install the assemblies in the BODY pockets. Test for free movement of the plungers. *Lightly* lubricate the body pockets, springs and plungers with Mobilgrease 77 or equivalent.

Caution: Do not overlubricate. Heavy lubrication may prevent clutch disengagement.
2. Install the FLANGE PLATE Σ into the DRIVE PLATE Π . *Lightly* lubricate both sides of the DRIVE PLATE and the machined face of the BODY with Mobilgrease 77 or equivalent.
3. Align the PLUNGERS with the tapered seats in the DRIVE PLATE.
4. Type S Clutch: Insert mounting screws through the FLANGE PLATE into the tapped holes in the BODY π . Alternately tighten the screws until flange plate is seated on the BODY.
- 4A. Type F Clutch: Insert mounting screws through the BODY Θ and FLANGE PLATE into the tapped holes in the INDEX DRIVE flange. Alternately tighten the screws until the FLANGE PLATE is seated on the BODY.
5. Assemble the DETECTOR PLATE Γ on the clutch BODY and secure both the DETECTOR PLATE and the PLUNGERS with the detector mounting screws.

Note: Type F Clutch only. If alternate assembly, with the clutch BODY mounted on the INDEX DRIVE flange is required, reassemble as follows:

Remove the mounting screws. Insert the mounting screws through the FLANGE PLATE first, and then the BODY, into the tapped holes in the INDEX DRIVE flange.

Warning: Do not remove the detector mounting screws as they must retain the plunger assembly.

6. Install the assembled clutch on the output shaft or flange of the INDEX DRIVE.
7. Prepare the DIAL, SPROCKET or DRIVEN MEMBER with a center hole and mounting holes to mate with the tapped holes in the DRIVE PLATE. (Refer to CAMCO assembly drawings.)
8. Install DIAL or DRIVEN MEMBER and check if it is free to rotate.
9. Tighten DIAL mounting screws. Disengage clutch and test for clearance between the DRIVE PLATE and BODY (approximately .002"). The center hole of the DIAL must also clear the FLANGE PLATE.

WARNING: Dial mounting screws must not protrude from the drive plate as they may lock against the adjacent surface making the clutch inoperative.

10. Remove the flange plate and dial-drive plate assembly.
Caution: Do not loosen the dial screws.
11. Using the DRIVE PLATE as a "Jig," drill and ream the DIAL dowel holes. Deburr all holes.
12. Install dowel pins through the DIAL into the DRIVE PLATE.

Warning: Dowel pins must not protrude from the drive plate as they may lock against the adjacent surface, making the clutch inoperative.

13. Reassemble the FLANGE PLATE and DIAL-DRIVE PLATE assembly to the clutch BODY.
14. Test for proper torque setting.

Note: For added reliability and/or high speed operation, a bronze bushing may be inserted between the DIAL PLATE and the FLANGE PLATE. Special bronze flange plates are also available from CAMCO.

DISASSEMBLY INSTRUCTIONS (Types F and S)

1. Remove DIAL mounting screws.
2. Remove DIAL or other driven member by tapping under the DIAL to overcome dowel pin friction.
3. Type S Clutch: Remove output shaft clamp screws.
- 3A. Type F Clutch: Remove mounting screws.
4. Remove the clutch from the index drive.
5. Type S Clutch: Remove mounting screws.

6. Place BODY with the PLUNGERS face down on a solid surface.
7. Remove DETECTOR MOUNTING screws which will release the PLUNGER assemblies.

Warning: The plunger assemblies are spring loaded and under tension. Bodily injury could result if the plunger assemblies are not retained against a solid surface.

WARNING
High humidity, contaminants or wash down applications may cause rust within the clutch resulting in operational failure. Lubricate every six months or more frequently as the applications require.

CAMCO CLUTCHES are precision assemblies and should not be modified. Modification of the clutch will VOID THE CAMCO WARRANTY.

TYPE D CLUTCH

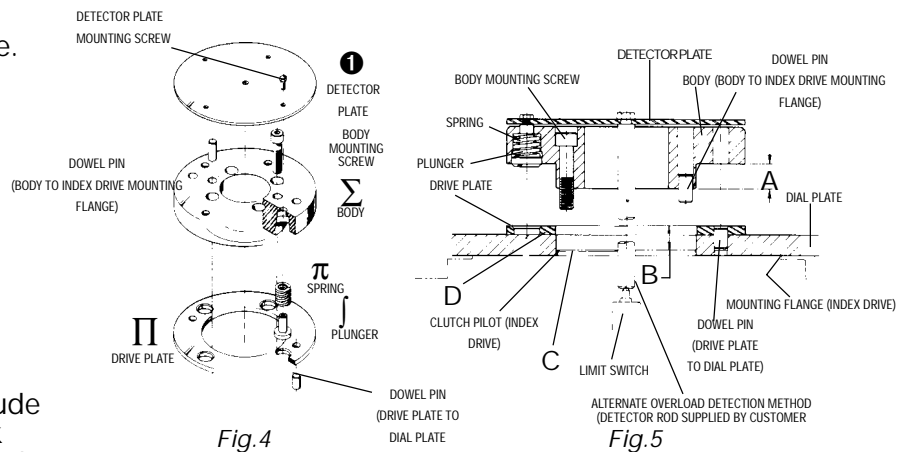

INSTALLATION INSTRUCTIONS TYPE D OVERLOAD CLUTCH FOR DIAL PLATE APPLICATIONS

ASSEMBLY INSTRUCTIONS

See Fig. 4 and Fig. 5

Important: To obtain maximum accuracy in positioning the DIAL PLATE, the INDEX DRIVE "CAM SHAFT" must be in the EXACT CENTER OF DWELL position. See CAMCO drawing applicable to the Index Drive Model.

1. Lubricate output shaft and dial mounting surface of the INDEX DRIVE with Mobilgrease 77 or equivalent.
2. Prepare the DIAL with center hole as required. (Refer to CAMCO assembly drawings.)
3. Place the DIAL on the output mounting flange of the INDEX DRIVE and check if it is free to rotate.

Note: Dowel pins are factory installed when the clutch is supplied with the INDEX DRIVE.

4. Install dowel pins in the INDEX DRIVE mounting flange to insure proper positioning to the clutch BODY.5. Insert BODY Σ into DRIVE PLATE Π and through the center hole of the DIAL.

Note: Do not assemble SPRINGS, PLUNGERS or DETECTOR PLATE on the BODY.

6. Attach the clutch BODY to the INDEX DRIVE output mounting flange with the body mounting screws.

Note: A .002" minimum to .004" maximum clearance gap must exist between the DRIVE PLATE and the BODY, around the full circumference of the clutch.

7. Clearance Procedure (See Fig. 5)
 - A. Measure dimension "A" (bottom surface of BODY to bottom surface of BODY detent).
 - B. Measure dimension "B" (top surface of DRIVE PLATE to top surface of clutch pilot).
 - C. Subtract "B" from "A".
 - D. If *less* than .002", add shim at surface "C" (between clutch pilot and bottom surface of BODY) to obtain clearance gap of .002" to .004".
 - E. If *greater* than .004" grind BODY, (between DRIVE PLATE and DIAL PLATE) to obtain clearance gap of .002" to .004".

8. Remove BODY. Insert PLUNGERS Γ into SPRINGS π and install the assemblies in the BODY pockets. Test for free movement of the plungers. *Lightly* lubricate the body pockets, springs and plungers with Mobilgrease 77 or equivalent.

Caution: Do not overlubricate. Heavy lubrication may prevent clutch disengagement.

9. Align the PLUNGERS with tapered seats in the DRIVE PLATE Π . Re-install BODY.
10. Rotate the DIAL PLATE to desired position. Place .010" shim stock between the BODY and the DRIVE PLATE and alternately tighten body mounting screws, clamping the DIAL PLATE. Shim stock should be placed at 90° intervals.

Caution: Do not cock the plunger. The plungers must retract evenly into the clutch body.

11. Using the BODY and DRIVE PLATE as a "JIG," drill and ream the DIAL PLATE dowel holes. The holes should not go completely through the DIAL PLATE. DIAL PLATE dowel pins should be .125" shorter than the combined thickness of the DIAL and DRIVE PLATES.

12. Disassemble, deburr and clean all parts. Remove .010" shim stock.13. Dowel pin the DRIVE PLATE to the DIAL PLATE.

Note: Dowel pins are factory installed when the CLUTCH *and* DIAL PLATE are supplied with the INDEX DRIVE.

Warning: Dowel pins must not protrude from the DRIVE PLATE or DIAL PLATE as they may lock against the adjacent surface, making the clutch inoperative.

14. *LIGHTLY* lubricate the DRIVE PLATE and mating surface of the clutch BODY with Mobilgrease 77 or equivalent.
15. Assemble complete clutch. Alternately tighten body mounting screws following the procedures in instruction #10.
16. Assemble the DETECTOR PLATE Θ on the clutch BODY and secure both the DETECTOR PLATE and the PLUNGERS with the detector mounting screws.
17. Check if DIAL PLATE can be disengaged.
18. Test for proper torque setting. The clutch should disengage within 10% to the name-plate torque rating.
Note: All clutches are torque tested by CAMCO prior to shipment.

DISASSEMBLY INSTRUCTIONS (TYPE D)

1. Remove DETECTOR MOUNTING screws which will release the PLUNGER assemblies.
2. Alternately loosen and remove the BODY mounting screws.

Warning: The plunger assemblies are spring loaded and under tension. Bodily injury could result if the plunger assemblies are not released *slowly* by the body mounting screws.

3. Remove the clutch BODY.
Note: It may be necessary to tap under the DIAL PLATE to overcome the friction caused by the dowel pins that register the body to the mounting flange.
4. Clean and inspect all parts for wear.
5. Lubricate per assembly instructions 1, 8, and 14.

WARNING

High humidity, contaminants or wash down applications may cause rust within the clutch resulting in operational failure. Lubricate every six months or more frequently as the applications require.

CAMCO CLUTCHES are precision assemblies and should not be modified. Modification of the clutch will VOID THE CAMCO WARRANTY.

APPLICATION RECOMMENDATIONS

1. Clutch operation in dusty or corrosive environments may require special preparation. Contact CAMCO for special modifications.
2. On applications other than the output of a CAMCO Index Drive, clutch speeds must not exceed 100 RPM.
3. High humidity, contaminants, or wash down applications may require special protection. If rust forms within the clutch, it may act as a solid coupling and will not release under overload conditions. Lubricate every six months or more frequently as the application requires.

Caution: Lubricate the spring pockets with a light film to grease. Heavy lubrication of the spring pocket may lock the plunger, due to hydraulic pressure, preventing clutch disengagement.

4. Use bronze bushings on sprockets, dials, gears or pulleys when used at the high end of the speed range (100 RPM) to reduce wear. Special bronze flange plates are available.
5. Clutch couplings require accurate shaft alignment of .003" TIR. Insure that a clearance gap is maintained between the body and the drive plate around the full circumference to the clutch (Type FC, C).
6. Use flange mounted clutches and clutch couplings whenever possible. These models provide superior mounting reliability (Type D, F, FC).
7. Dowel pins should not protrude from the drive plate or driven members, as they may lock against the adjacent surface.
8. Do not operate without the detector limit switch, electrically disconnecting the prime mover (motor), as galling of the contacting surfaces may result.
9. On high inertia applications, braking the prime mover is recommended, in the dwell cycle of the INDEX DRIVE, to minimize over travel.
10. CAMCO recommends using limit switches with rated travel not exceeding .008" for actuation.
9. On high inertia applications, braking the prime mover is recommended, in the dwell cycle of the INDEX DRIVE, to minimize over travel.
10. CAMCO recommends using limit switches with rated travel not exceeding .008" for actuation.

11. The torque required to re-engage the clutch is usually 25% of the rating. Contact CAMCO for special design, anti-friction materials if the clutch is to be used with very low torque settings.
12. Never use the clutch with a torque setting close to the calculated operating torque. Actual torques may be higher. Torque spring tolerances and coefficients of friction vary with temperature and application. Allow 130% (1.3 service factor) when applying a CAMCO clutch.



A **DOVER** COMPANY

Automation
Robohand FERGUSON
CAMCO

CAMCO & FERGUSON Products
1444 South Wolf Road
Wheeling, IL 60090
USA
ph: 847-459-5200
toll-free: 800-645-5200
fax: 847-459-3064
camco@destaco.com

ISO 9001:2000 Registered

DE-STA-CO Headquarters
Auburn Hills, Michigan USA
248-836-6700
marketing@destaco.com

www.destaco.com

DE-STA-CO Europe
Germany
+49-6171-705-0
europe@destaco.com

DE-STA-CO Asia
Thailand
+66-2-326-0812
info@destaco.com

DE-STA-CO South America
Brazil
0800-124070
samerica@destaco.com

This publication is for information purposes only and should not be considered a binding description of the product except is confirmed in writing by Industrial Motion Control, LLC/DE-STA-CO

© DE-STA-CO 2004-2014
All rights reserved
Printed in U.S.A.
SKU 0136 (6/99)
99A45938000000