



Installation Manual

Frameworkx Gutter and Capping

August 2012 / 84-900030-000

Brunswick[®] 

CUSTOMER SERVICE

A tradition in excellence.

Frameworkx Gutter and Capping Installation Manual

© August 2012 by the Brunswick Bowling and Billiards Corporation. All rights reserved.

A-2, BallWall, Frameworkx, GS-Series, Pinball Wizard, and Tel-E-foul, and are registered trademarks of the Brunswick Bowling and Billiards Corporation.

Reorder Part No. 84-900030-000

Notice: If available, updates to this manual can be found on-line at www.centermaster.com.

All information contained in this document is subject to change without notice.

Brunswick Bowling and Billiards Corporation
525 West Laketon Avenue
P.O. Box 329
Muskegon, MI 49443-0329
U.S.A.

231.725.3300

Safety

Throughout this publication, “Warnings” and “Cautions” (accompanied by one of the International HAZARD Symbols) are used to alert the mechanic to special instructions concerning a particular service or operation that may be hazardous if performed incorrectly or carelessly. They are defined below. **OBSERVE AND READ THEM CAREFULLY!**

These “Safety Alerts” alone cannot eliminate the hazards that they signal. Strict compliance to these special instructions when performing the service, plus training and “Common Sense” operation are major accident prevention measures.



NOTE or IMPORTANT!:

Will designate significant informational notes.



WARNING!

Will designate a mechanical or nonelectrical alert which could potentially cause personal injury or death.



WARNING!

Will designate electrical alerts which could potentially cause personal injury or death.



CAUTION!

Will designate a mechanical or nonelectrical alert which could potentially cause product damage.



Will designate grounding alerts.

TABLE OF CONTENTS

Harmful Chemicals.....	6
Brunswick Gutter and Capping Packaging.....	7
Ball Return and Division Capping	10
Existing Gutters and Capping Removal	10
Preparation.....	10
Ball Return Capping Support Frames.....	11
Pre-Mark Support Frame Side Rails	11
Assembly	12
Install Support Spacers.....	16
Installation of Ball Return Support Frames.....	18
Division Support Strip Assembly	21
Division Support Strip Installation.....	22
Preparation	22
Installation of Division Support Strips (inside division).....	22
Gutter Joint Support Brace Installation	25
Gutter Installation	26
Existing Foundation	26
System B2000 Lane Surface - With Truss Foundation	26
New Foundation	27
Stand-Alone (Cosmetic) Covers Installation	31
Ball Return Capping - New and Existing Foundations	32
Layout Capping Clips.....	32
Install Capping Clips	35
Ball Return Capping.....	37
Ball Return Capping Removal	38
Ball Return Cover.....	39
Division Capping and Existing Foundation.....	40
Gutters at Division	40
Division Capping.....	40
Division Cover	41

WARRANTY AND SERVICE POLICY

If any defects in material or workmanship appear during the first three months after installation, the defective part will be repaired or replaced, at Brunswick's option, with no charge to the Customer.

If any defects in material appear during the nine months following the initial three month warranty period, the defective part will be repaired or replaced, at Brunswick's option, with no charge to the Customer for parts. The Customer must assume all other costs in making the repair or replacement.

All service calls during the first three months of the warranty period, resulting from the inability of the Customer's mechanics to perform required adjustments or maintenance, will be billed directly to the Customer.

Brunswick reserves the right to change the design of any product, but assumes no responsibility to incorporate such design changes on products already sold.

The warranty applies only to new products installed by Brunswick and extends only to the original purchaser. Repairs or replacements made by anyone not approved by Brunswick void the warranty.

Under no circumstances shall the Seller or Manufacturer be liable for loss of profits or other direct or indirect costs, expenses, losses, or damages arising out of defects in or failure of parts.

Replacement Parts Under the Warranty

All service parts are F.O.B. the installation site both during and after the warranty period. The price of parts includes delivery by standard means, such as United Parcel Service (UPS). Any expense resulting from expedited delivery, such as air freight, will be billed to the Customer.

During the one year period, parts which are faulty due to material or workmanship will be replaced or repaired free of charge only if the old part is properly identified and turned in for credit. Identify the defective part by attaching a tag containing the part name and part number. Light bulbs are not covered by the warranty.

Contact the Warranty Department at 1-231-725-3433.

HARMFUL CHEMICALS



WARNING! Although the gutters and capping you have just purchased are made from strong and durable PVC plastic, it has been determined that some lane conditioner, lane cleaner, and all-purpose cleaners may contain chemicals that can damage your gutters and capping. Some of the chemicals are Toluene, Methyl Ethyl Ketone and Chlorinated Solvents.

Please refer to the manufacturer's information on the products you use around your lane area, to see if they are compatible with and not harmful to PVC plastics. Failure to do so may damage the gutters and capping and will **void your warranty.**

Brunswick offers a full line of conditioners and cleaners for your center. For information on these products contact your Brunswick distributor or Brunswick After Market Specialist.

BRUNSWICK GUTTER AND CAPPING PACKAGING

Page 1 of 1

MODEL NUMBER CONFIGURATION			
<i>BRUNSWICK BOWLING & BILLIARDS CORPORATION</i>			
Drawing Number:		L2-600061-XXX	Rev. No: C
DESCRIPTION: MNC - RETURN CAPPING			
REV.	QTY.	PART NUMBER	DESCRIPTION OF PACKAGE
	1.00	84-860740-XXX	PKG. - RETURN CAPPING & HARDWARE

Page 1 of 1

MODEL NUMBER CONFIGURATION			
<i>BRUNSWICK BOWLING & BILLIARDS CORPORATION</i>			
Drawing Number:		L2-600062-XXX	Rev. No: F
DESCRIPTION: MNC - DIVISION CAPPING			
REV.	QTY.	PART NUMBER	DESCRIPTION OF PACKAGE
	1.00	84-860553-XXX	PKG. – DIVISION CAPPING
	1.00	84-860734-XXX	PKG. - DIVISION CAPPING, CLEAR - ROHS, NON GLOW
	*1.00	84-900030-000	MANUAL - FWX CUTTER & CAPPING INSTALLATION (PBW)
* PER CENTER			

MODEL NUMBER CONFIGURATION			
<i>BRUNSWICK BOWLING & BILLIARDS CORPORATION</i>			
Drawing Number:		L2-600063-000	Rev. No: A
DESCRIPTION: MNC - RETURN TEL-E-FOUL COVER			
REV.	QTY.	PART NUMBER	DESCRIPTION OF PACKAGE
	1.00	84-860603-000	PKG. - RETURN COVER, TEL-E-FOUL

MODEL NUMBER CONFIGURATION			
<i>BRUNSWICK BOWLING & BILLIARDS CORPORATION</i>			
Drawing Number:		L2-600064-000	Rev. No: A
DESCRIPTION: MNC - DIVISION TEL-E-FOUL COVER			
REV.	QTY.	PART NUMBER	DESCRIPTION OF PACKAGE
	1.00	84-860602-000	PKG.- DIVISION COVER, TEL-E-FOUL

MODEL NUMBER CONFIGURATION			
<i>BRUNSWICK BOWLING & BILLIARDS CORPORATION</i>			
Drawing Number:		L2-600066-000	Rev. No: A
DESCRIPTION: MNC - DIVISION CAPPING BARRIER			
REV.	QTY.	PART NUMBER	DESCRIPTION OF PACKAGE
	1.00	84-860564-000	PKG. - DIVISION CAPPING BARRIER WALL

MODEL NUMBER CONFIGURATION			
<i>BRUNSWICK BOWLING & BILLIARDS CORPORATION</i>			
Drawing Number:		L2-600079-000	Rev. No: C
DESCRIPTION: MNC - DIVISION SUPPORT LUMBER			
REV.	QTY.	PART NUMBER	DESCRIPTION OF PACKAGE
	40	11-081208-000	2" ROBERTSON
	1	84-860554-001	PKG - CAPPING SUPPORT LUMBER
	15	84-860858-001	SPACER ANCHOR STRIP (DIVISION)
	3	84-860858-003	SPACER ANCHOR STRIP (END DIVISION)
	8	84-860858-004	SPACER GUTTER COUPLER

MODEL NUMBER CONFIGURATION			
<i>BRUNSWICK BOWLING & BILLIARDS CORPORATION</i>			
Drawing Number:		L2-600082-000	Rev. No: B
DESCRIPTION: MNC - RETURN CAPPING SUPPORT LUMBER			
REV.	QTY.	PART NUMBER	DESCRIPTION OF PACKAGE
	40	11-081208-000	2" ROBERTSON SCREW
	2	84-860554-001	PKG - CAPPING SUPPORT LUMBER
	1	84-860555-000	PKG - RETURN CAPPING SUPPORT SPACER
	3	84-860858-001	SPACER ANCHOR STRIP (DIVISION)
	15	84-860858-002	SPACER ANCHOR STRIP (BALL RETURN)
	8	84-860858-004	SPACER GUTTER COUPLER

MODEL NUMBER CONFIGURATION			
<i>BRUNSWICK BOWLING & BILLIARDS CORPORATION</i>			
Drawing Number:		L2-600098-XXX	Rev. No: E
DESCRIPTION: MNC - GUTTER, GUTTER HARDWARE AND COVER FOR STAND ALONE GUTTER, LANE PAIR			
REV.	QTY.	PART NUMBER	DESCRIPTION OF PACKAGE
	2	84-860622-XXX	PKG. – COVER, STAND ALONE GUTTER (SEE TAB CHART)
	2	84-860621-000	PKG. – GUTTER HDWE. WITH ADAPTER BLOCKS
	2	84-860764-XXX	PKG. – GUTTER ASS'Y (SEE TAB CHART)
	*1.00	84-900032-000	OPERATIONS AND SERVICE MANUAL – PINBALL WIZARD
* PER CENTER			

BALL RETURN AND DIVISION CAPPING

The following instructions list the necessary steps to install new gutters in new or existing centers. Different lane surfaces may require variations on these instructions. Make sure you refer to the text and/or graphics for the specific lanes within your center BEFORE performing any necessary foundation modifications.

EXISTING GUTTERS AND CAPPING REMOVAL

Preparation

Remove and discard existing Tel-E-Foul castings, gutters, and capping. Remove any Nu-Wood or other shim materials that have been installed in the foundation at the division and ball returns.

For Brunswick gutter and capping to operate correctly the support lumber will need to be 1-5/16" (mm) above the lane surface and the required space for the gutter is 9-3/4" from the capping support lumber to the edge of the lane. Refer to *Figure 1*.

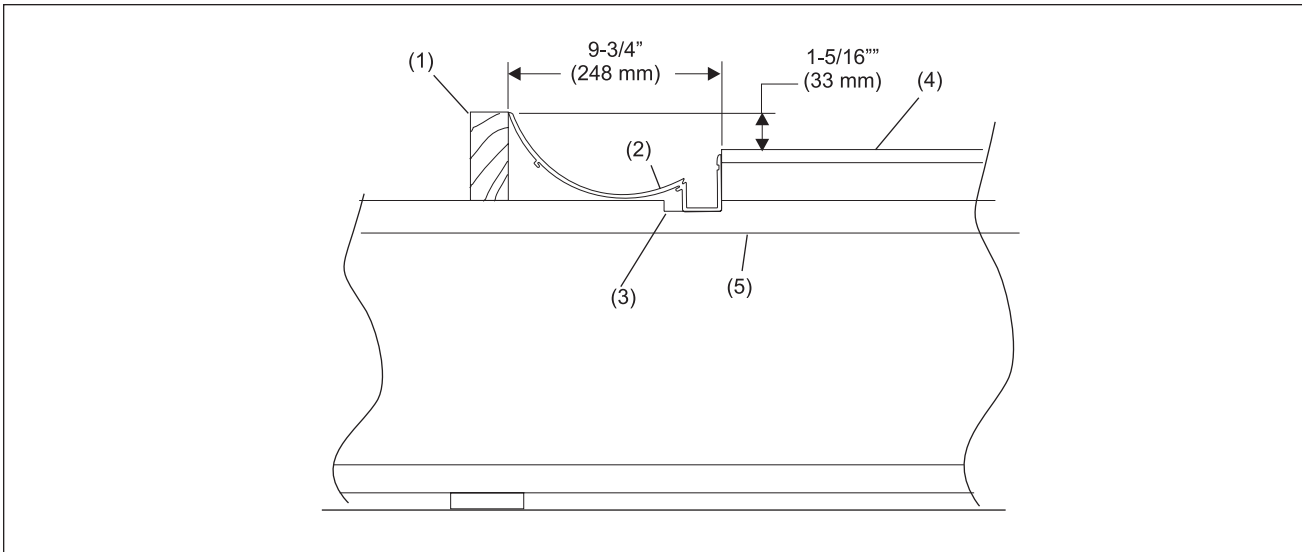

Figure 1. Gutter Preparation

- | | | |
|----------------------------|-------------|----------------|
| (1) DIVISION SUPPORT STRIP | (2) GUTTER | (3) ROUTE AREA |
| (4) LANE SURFACE | (5) I-JOIST | |

BALL RETURN CAPPING SUPPORT FRAMES

Pre-Mark Support Frame Side Rails

To aid in the installation of the gutter spacers, mark the I-joist locations on the side rails before assembling capping support frames.

1. Mark the support frame side rails at each I-joist location by laying the side rails along the foundation sequentially as shown in *Figure 2*.

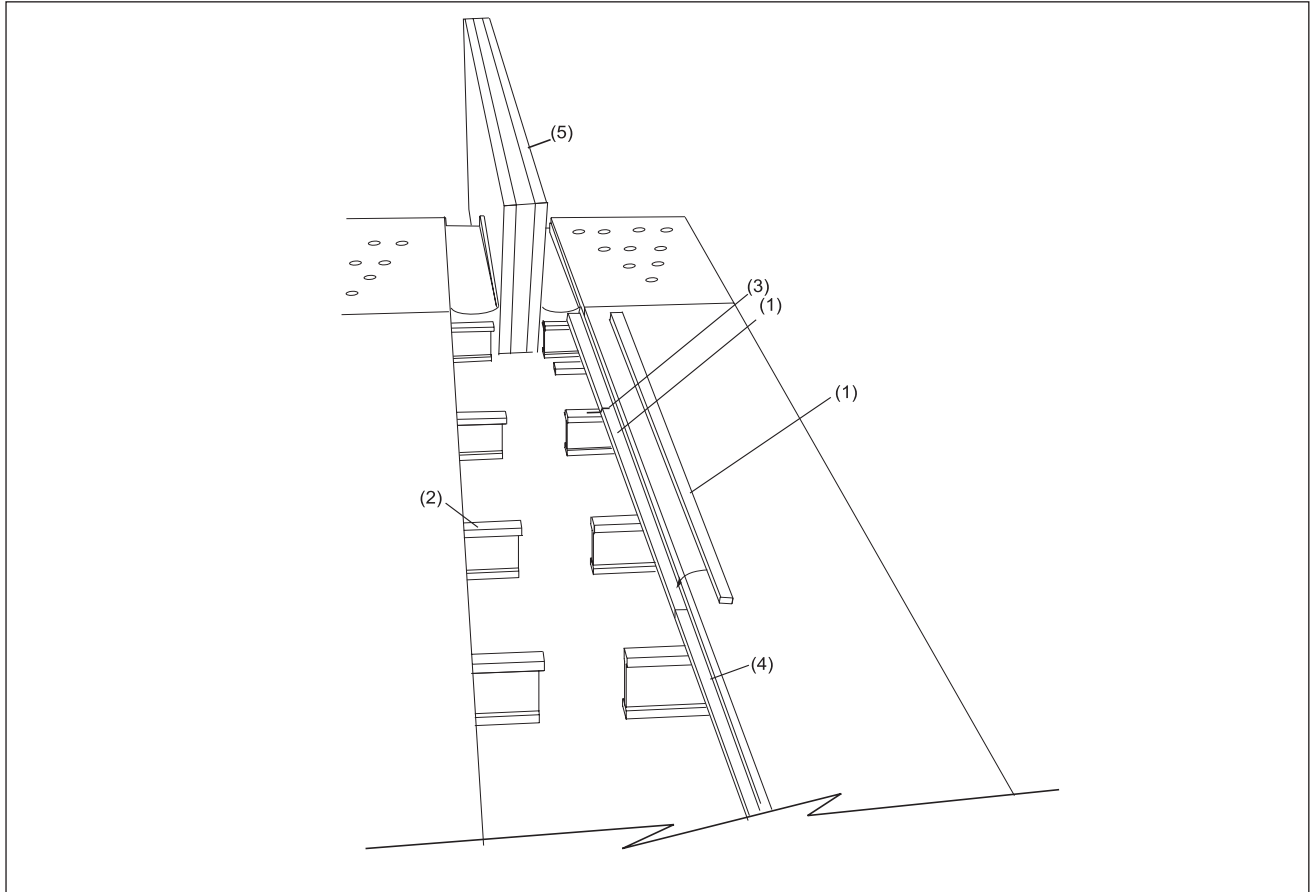

Figure 2. Mark Support Frame Side Rails

- | | | |
|---------------------------------------|---|------------------------------|
| (1) PINSETTER SUPPORT FRAME SIDE RAIL | (2) FOUNDATION | (3) MARK EACH BOARD LOCATION |
| (4) COMMON SUPPORT FRAME SIDE RAIL | (5) BALL RETURN KICKBACK (GS-SERIES PINSETTERS) | |

Assembly

Four support frames are required, the length and quantities are listed below:

- (1) Ea. - 176-3/8" (4480 mm) long Pinsetter End
- (2) Ea. - 176-3/8" (4480 mm) long Common Piece
- (1) Ea. - 176-3/8" (4480 mm) long Approach End

Assemble the ball return capping and gutter support frame assemblies. Refer to *Figures 3*.

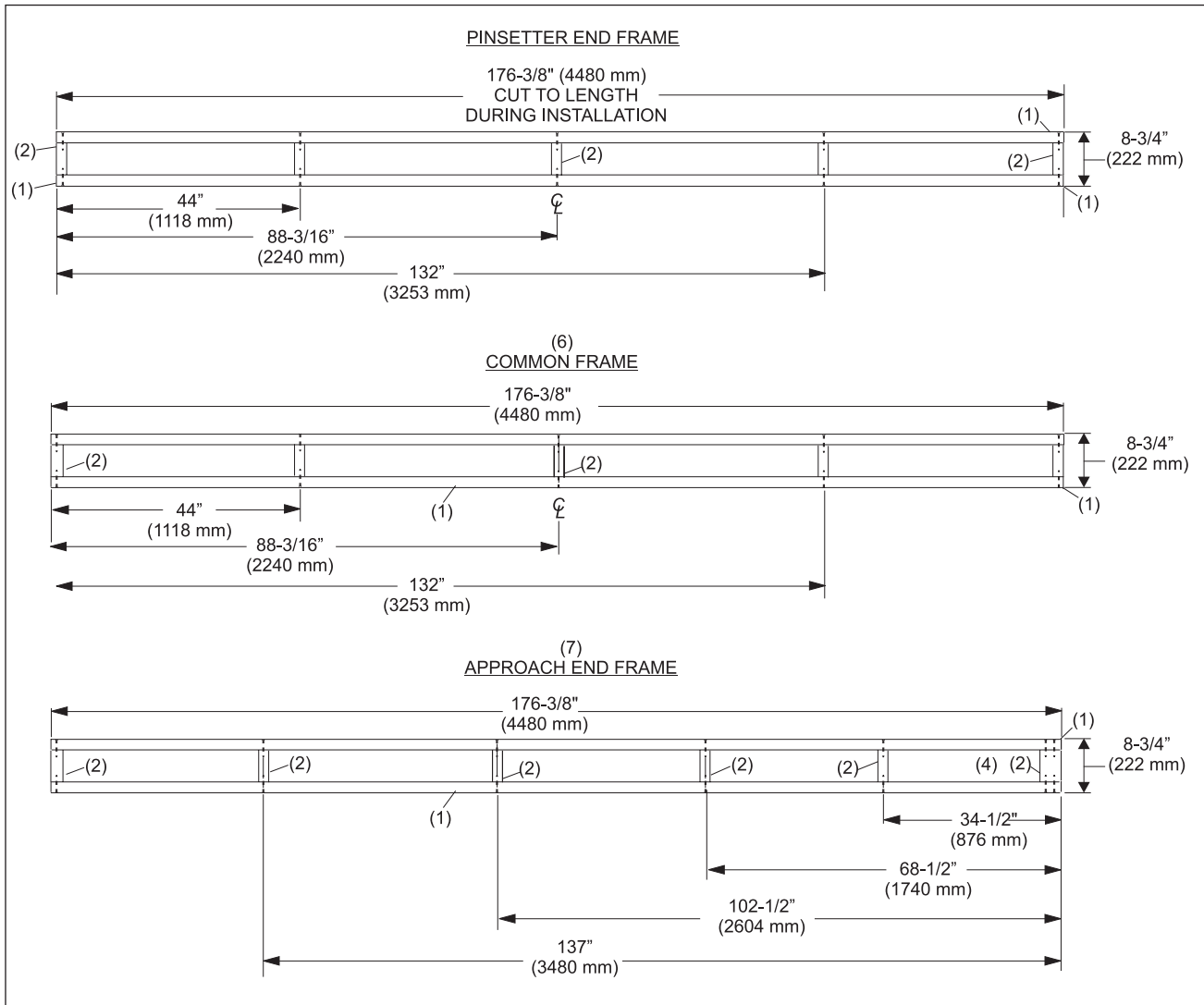

Figure 3. Ball Return Gutter and Capping Support Frames

- | | | |
|--|---|---|
| (1) SIDE RAIL -
1-1/2" X 3-3/4" X 176-3/8" 4480 mm) | (2) SPACER - 1-1/2" X 3-3/4" X 5-3/4"
(146 mm) | (3) #2-1/2", ROBERTSON FLAT
HEAD SCREW |
| (4) PLYWOOD BOX | (5) PINSETTER END FRAME [QTY. 1]
CUT TO FINAL LENGTH | (6) COMMON FRAME [QTY. 2] |
| (7) APPROACH FRAME [QTY. 1] | | |

1. Position the 1-1/2" x 3-3/4" x 5-3/4" (146 mm) spacers between the side rails and secure with four 2-1/2" ring shank nails for each spacer. Refer to *Figure 4*.

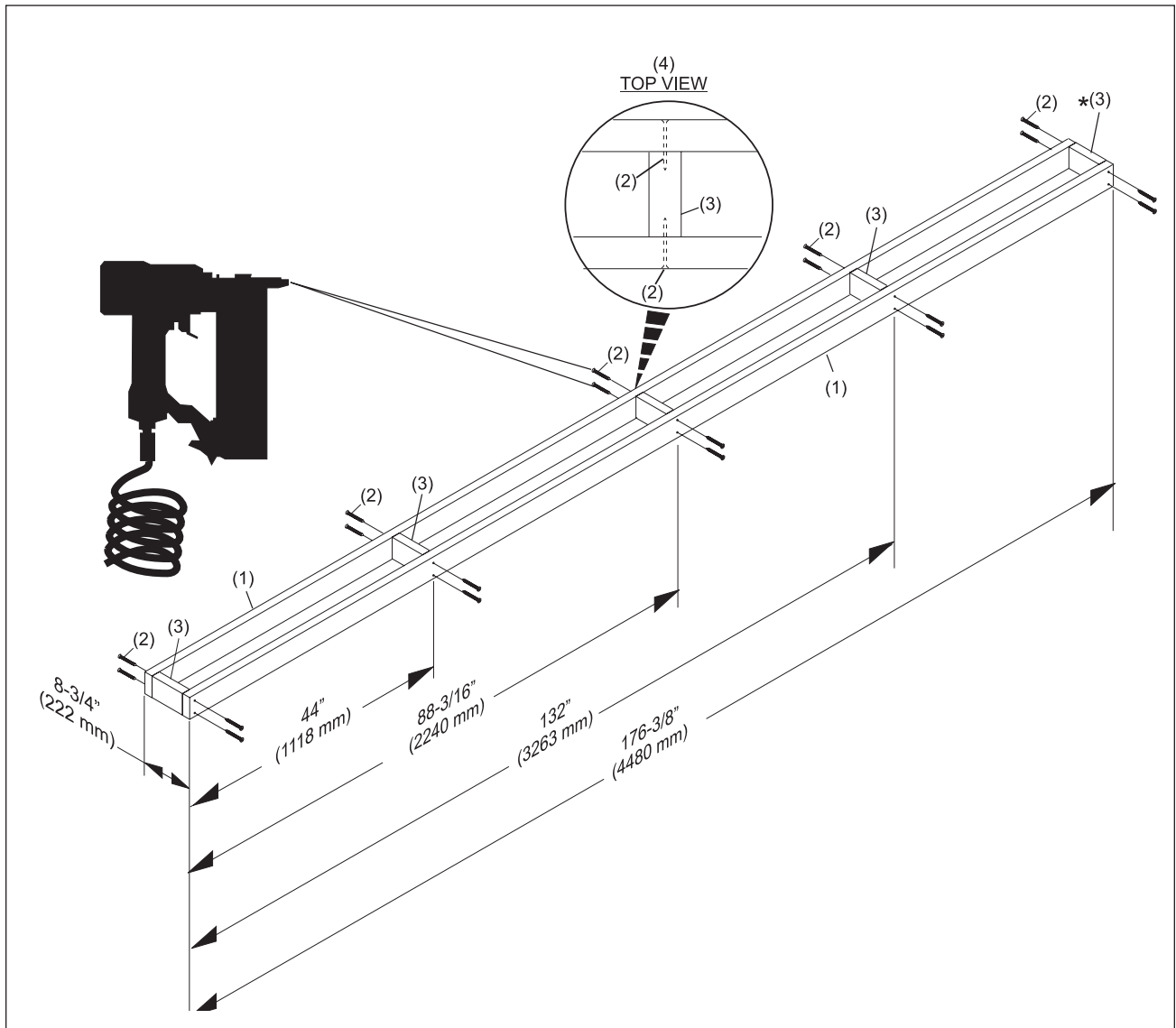

Figure 4. PINSETTER END Support Frame

- | | | |
|---|-----------------------------|---|
| (1) SIDE RAIL -
1-1/2" X 3-3/4" X 176-3/8" | (2) 2-1/2" RING SHANK NAILS | * (3) SPACER - 1-1/2" X 3-3/4" X 5-3/4"
(146 mm) |
| (4) TOP VIEW | | |

i **NOTE:** Do not install until pinsetter end support has been cut to length.

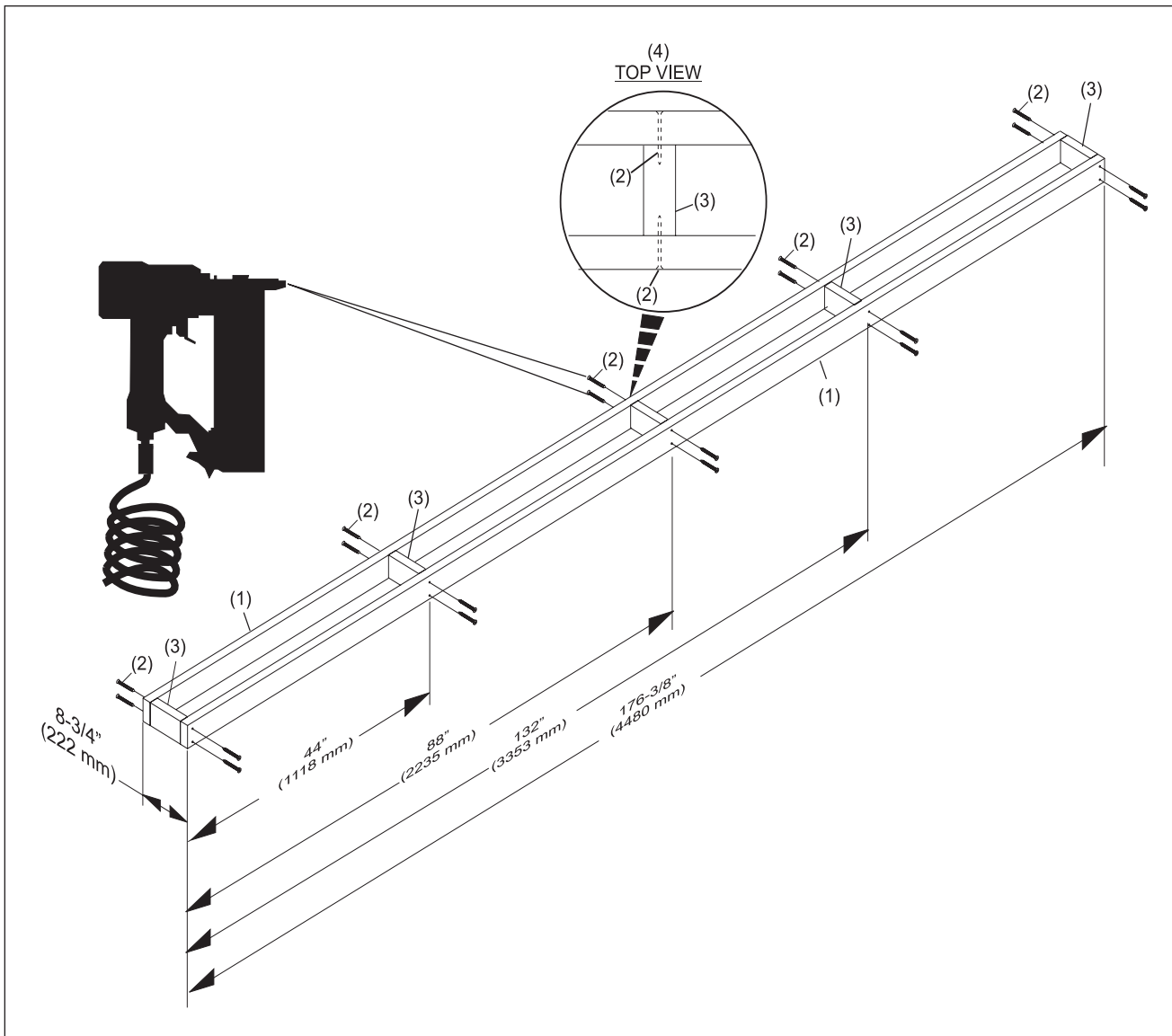

Figure 5. COMMON Support Frame (quantity of 2 required)

- | | | |
|---|----------------------------|---|
| (1) SIDE RAIL -
1-1/2" X 3-3/4" X 176-3/8" | (2) 2-1/2" RING SHANK NAIL | (3) SPACER - 1-1/2" X 3-3/4" X 5-3/4"
(146 mm) |
| (4) TOP VIEW | | |



NOTE: The spacer closest to the foul line (item 5) on the Approach End support frame must be installed horizontally as shown in Figure 6.

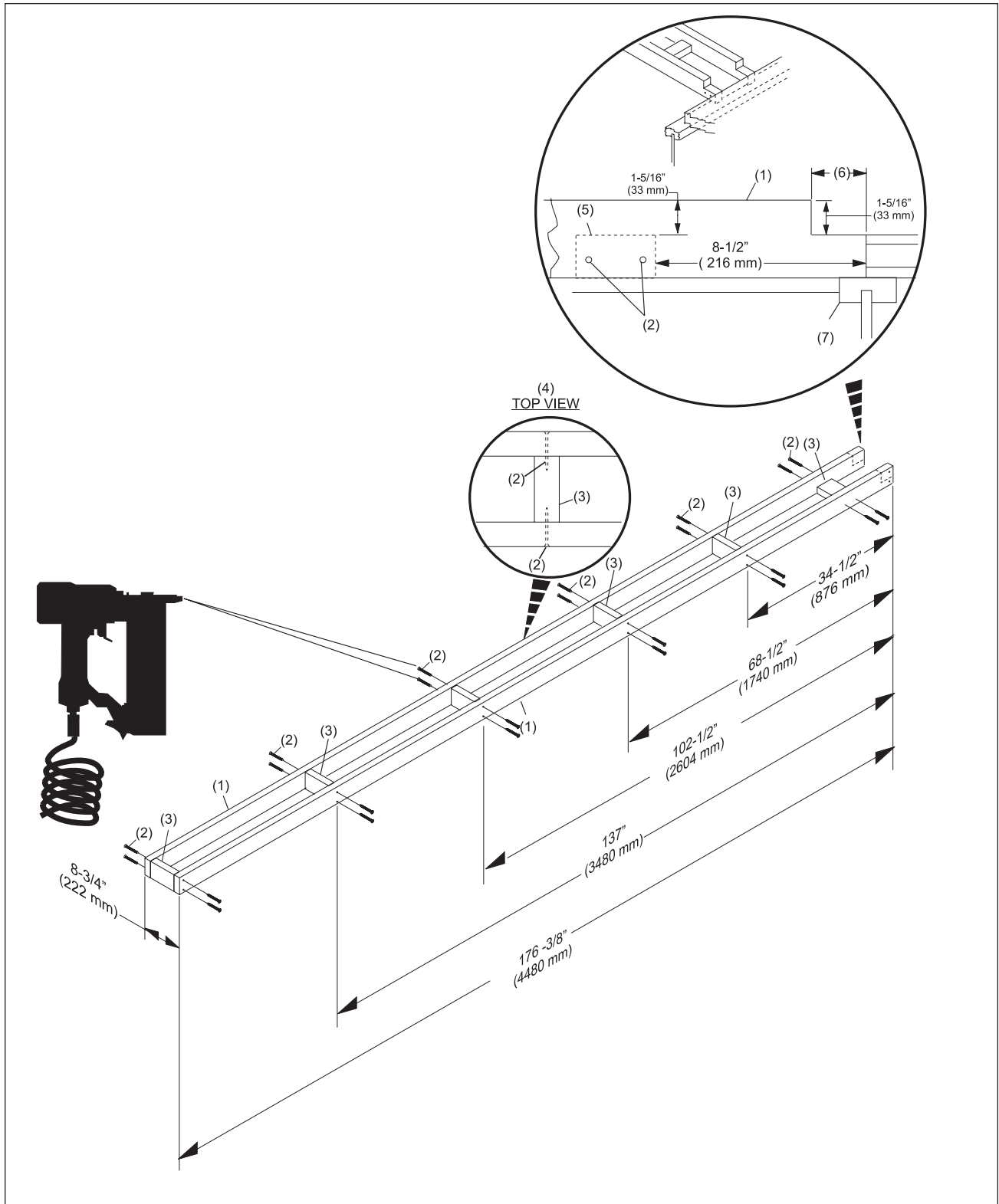

Figure 6. APPROACH end Support Frame

- | | | |
|--|---------------------------------|---|
| (1) SIDE RAIL -
1-1/2" X 3-3/4" X 176-3/8"
(4480 mm) | (2) 2-1/2" RING SHANK NAIL | (3) SPACER - 1-1/2" X 3-3/4" X 5-3/4"
(146 mm) |
| (4) TOP VIEW | (5) ROTATE SPACER 90
DEGREES | (6) APPROXIMATELY 2" (508 mm) |
| (7) I-JOIST | | |

Install Support Spacers

1. Flip support frame upside down.
2. Center the support spacers on the I-Joist location marks made on the support side rails earlier.
3. Apply adhesive.
4. Secure long support spacers to the support frame with 1-1/2" ring shank nails.

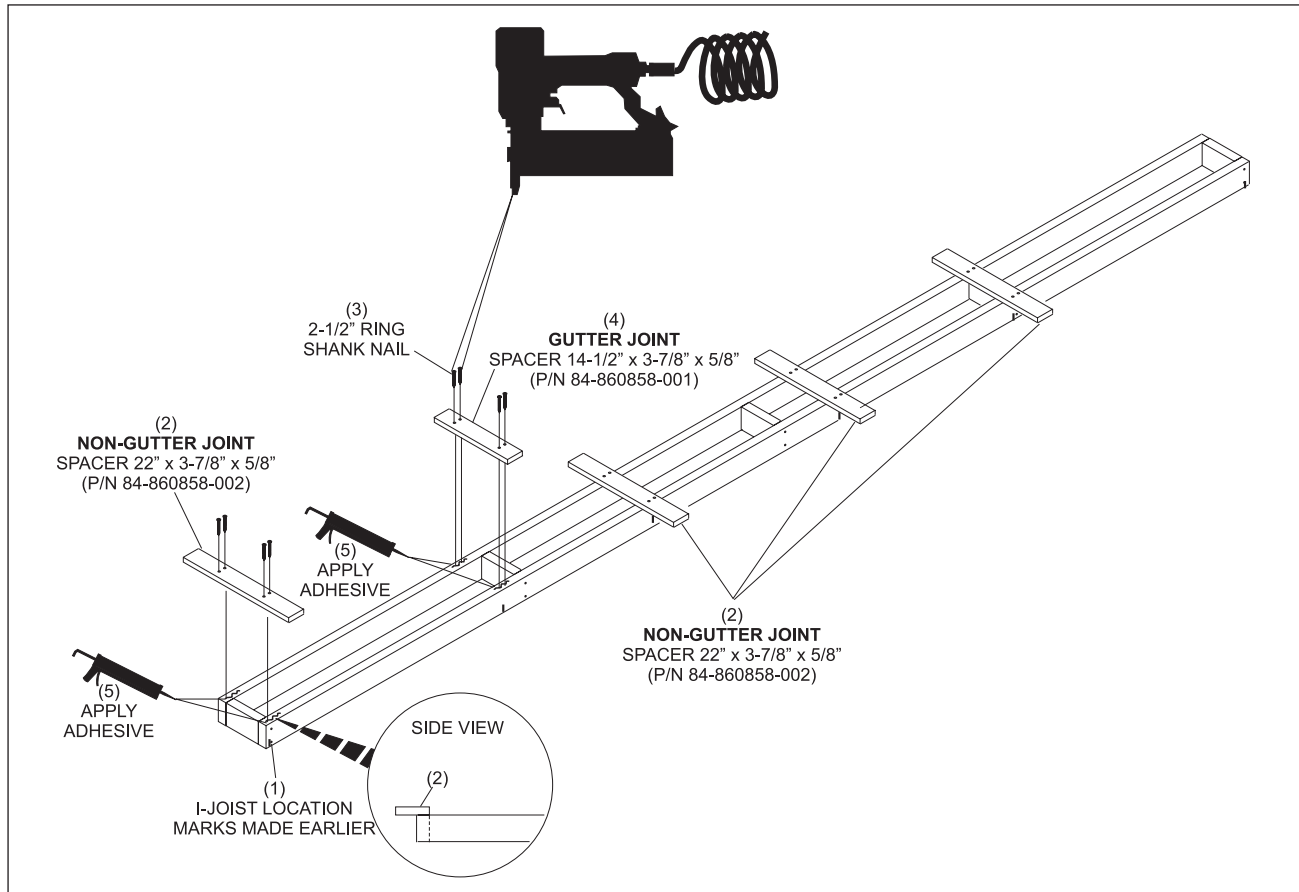

Figure 7. Pinsetter and Common End Support Frame

- | | | |
|---|---|----------------------------|
| (1) I-JOIST LOCATION MARKS MADE EARLIER | (2) NON-GUTTER JOINT SPACER 22" X 3-7/8" X 5/8" [P/N 84-860858-002] | (3) 1-1/2" RING SHANK NAIL |
| (4) GUTTER JOINT SPACER 14-1/2" X 3-7/8" X 5/8" [P/N 84-860858-001] | (5) APPLY ADHESIVE | |

5. Secure short support spacers (84-860858-000) with 1-1/2" ring shank nails where gutter joints occur.

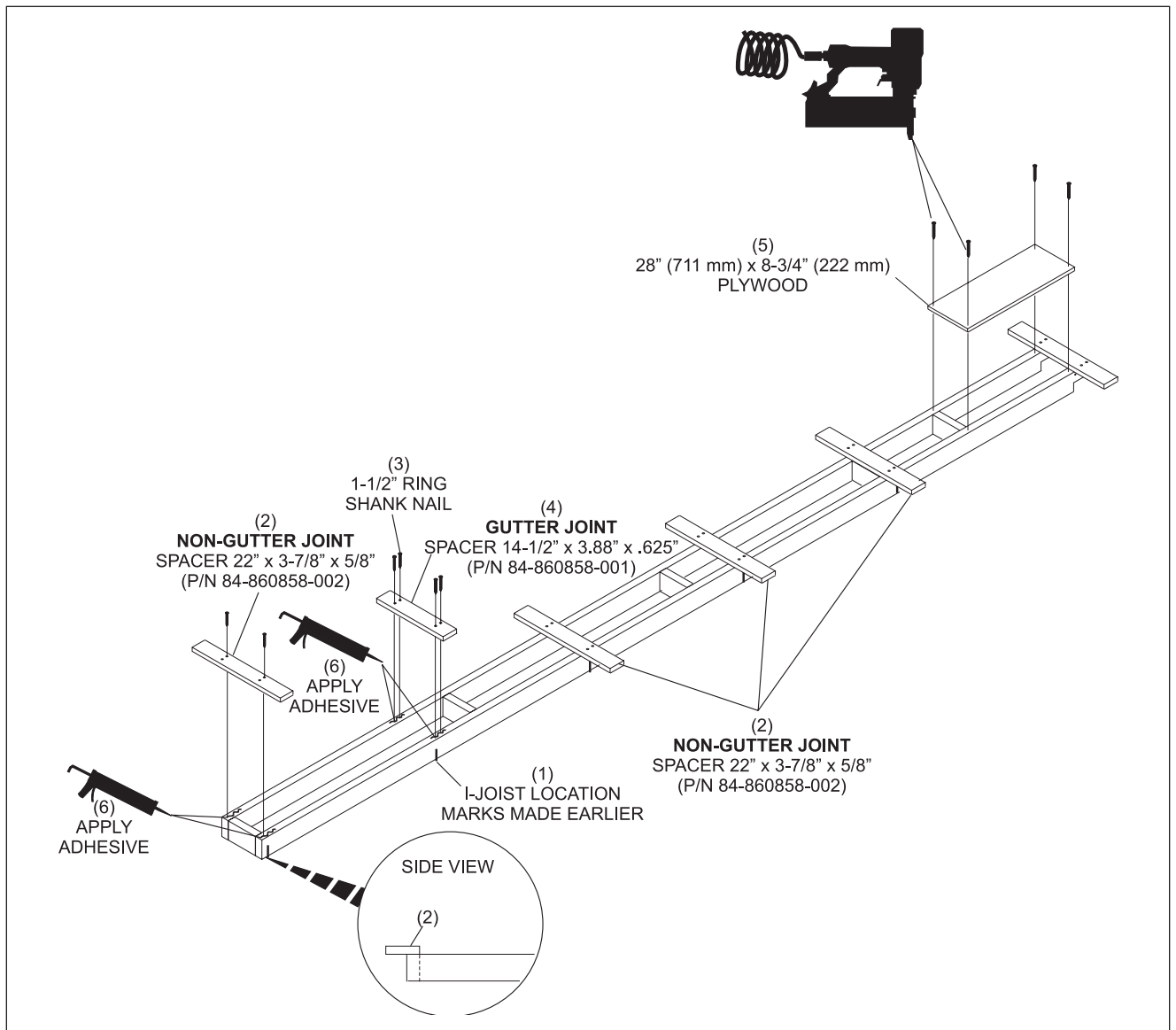

Figure 8. Approach End Support Frame

- | | | |
|---|---|----------------------------|
| (1) I-JOIST LOCATION MARKS MADE EARLIER | (2) NON-GUTTER JOINT SPACER 22" X 3-7/8" X 5/8" [P/N 84-860858-002] | (3) 1-1/2" RING SHANK NAIL |
| (4) GUTTER JOINT SPACER 14-1/2" X 3-7/8" X 5/8" [P/N 84-860858-001] | (5) 28" X 8-3/4" (711 mm) X 222 mm PLYWOOD | (6) APPLY ADHESIVE |

Installation of Ball Return Support Frames

1. Cut centering blocks to dimensions shown in *Figure 9*. Creating a 45° chamfer (*Figure 9*) allows for easy removal of blocks after frames are assembled.
2. Butt notched end of the 176-3/8" (4480 mm) approach end frame assembly against the foul line. Refer to *Figures 9 and 10*.

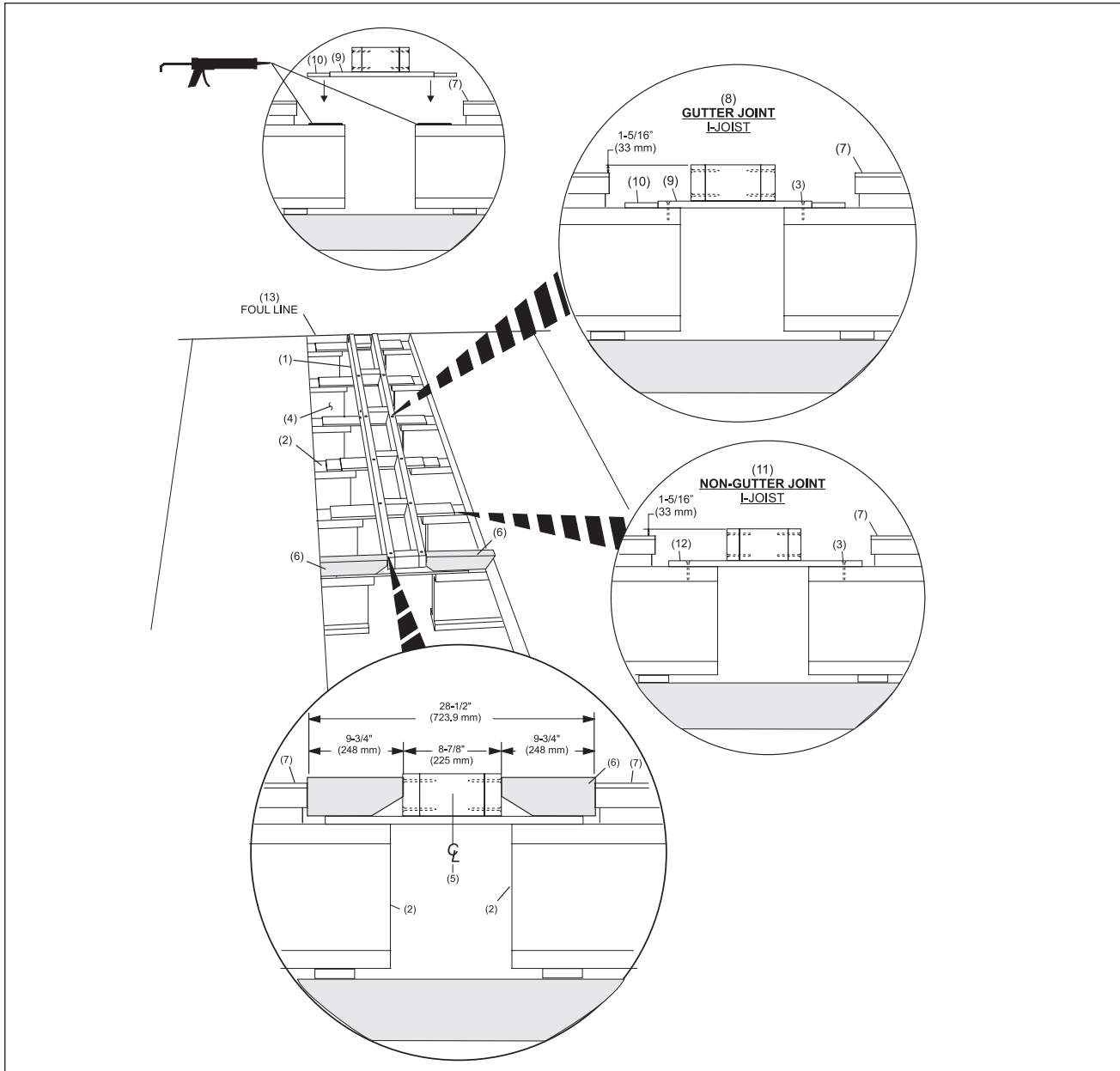

Figure 9. Secure Ball Return Frames to Foundation

- | | | |
|---|-------------------------------|--|
| (1) BALL RETURN FRAME ASSEMBLY | (2) FOUNDATION | (3) 2" ROBERTSON FLAT HEAD SCREWS |
| (4) GUTTER OPENING | (5) BALL RETURN CENTER LINE | (6) CENTERING BLOCKS |
| (7) LANE | (8) GUTTER JOINT I-JOIST | (9) GUTTER JOINT SUPPORT SPACER
14-1/2" X 3-7/8" X 5/8"
[P/N 84-860588-001] |
| (10) GUTTER JOINT
1/2" X 3-7/8 X 3-7/8" SPACER | (11) NON GUTTER JOINT I-JOIST | (12) NON GUTTER JOINT SUPPORT
SPACER 22" X 3-7/8" X 5/8"
[P/N 84-860588-002] |
| (13) FOUL LINE | | |

3. Center the frame between the lanes.
4. Secure the frame to the foundation with #10 x 1-1/2" Robertson screws.



***NOTE:** Making centering blocks as shown in Figure 9 makes centering the frames easier.*

5. Using the same procedure as used on the approach frame, install the two 176-3/8" (4.48 m) common frames.
6. Measure the distance remaining to the kickback and cut the fourth 176-3/8" (4.48 m) pinsetter frame to the required length.
7. Install the cut frame assembly.

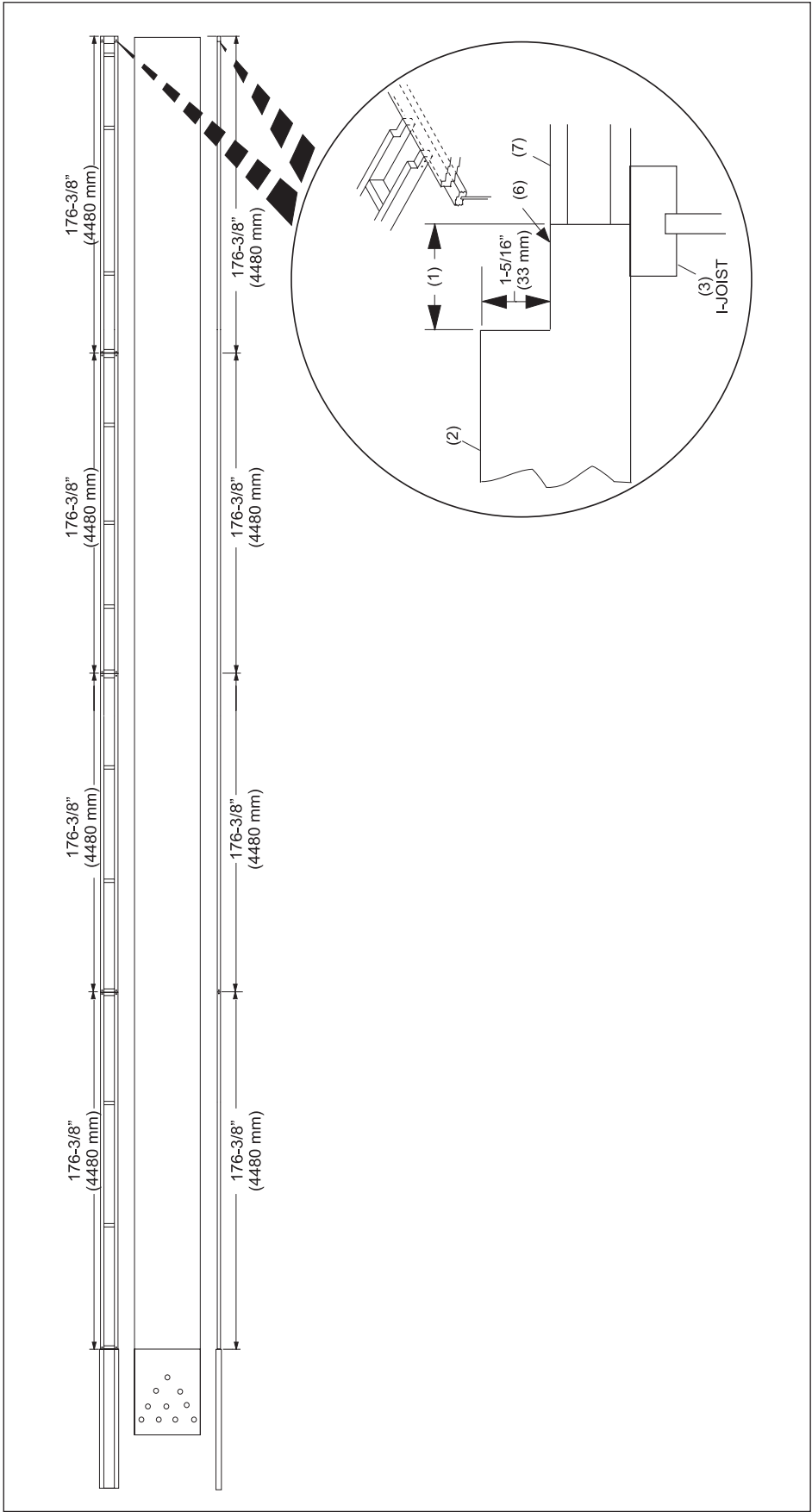

Figure 10. Secure Ball Return Support Frames

- (1) APPROXIMATELY 2" (51 mm)
- (2) SIDE RAIL
- (3) I-JOIST
- (4) CUT FLUSH WITH APPROACH
- (5) APPROACH

DIVISION SUPPORT STRIP ASSEMBLY

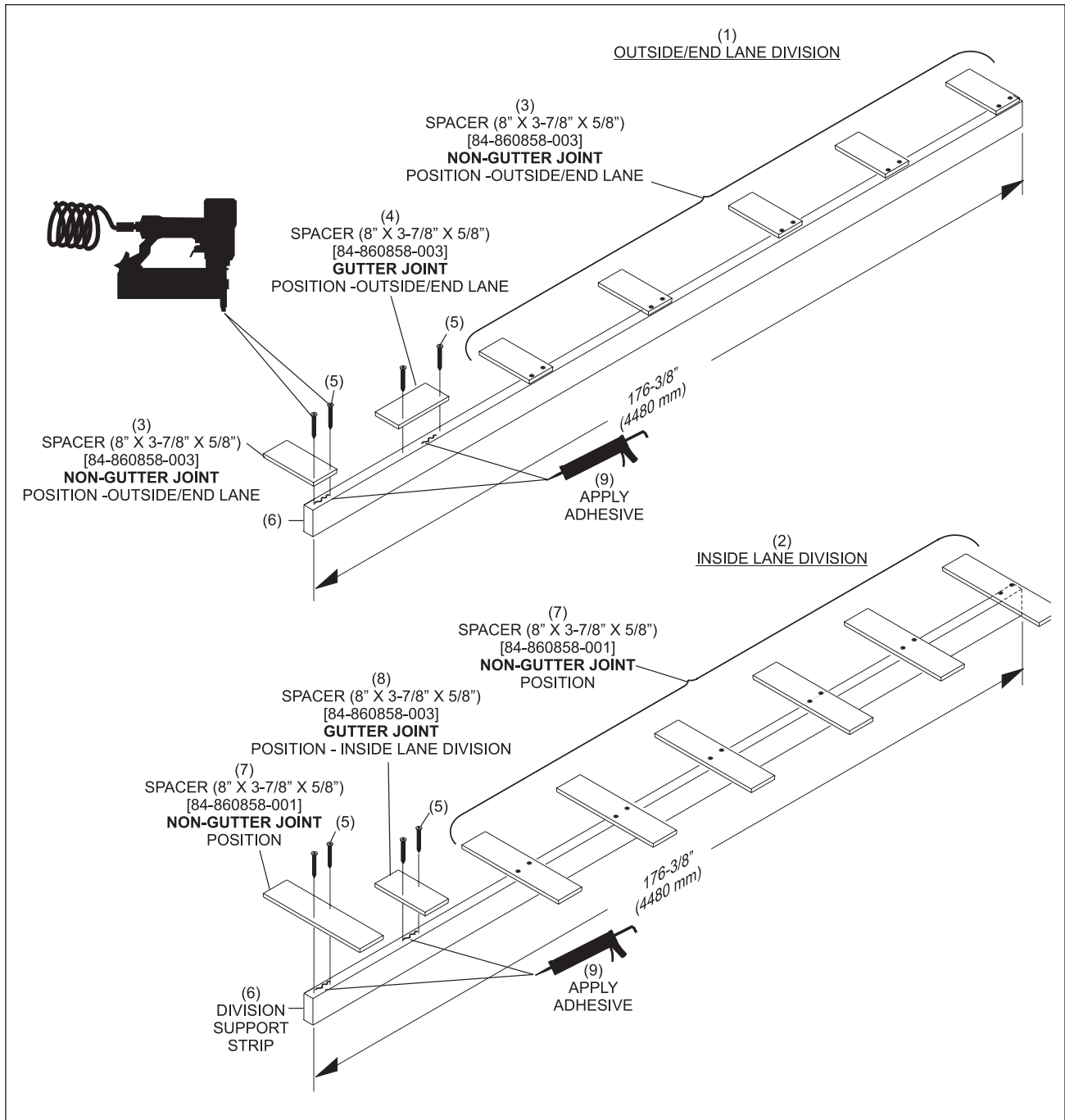

Figure 11. Division Support Strip

- | | | |
|---|---|---|
| (1) OUTSIDE LANE DIVISION | (2) INSIDE LANE DIVISION | (3) SPACER 8" X 3-7/8" X 5/8"
[P/N 84-860858-003] NON-GUTTER
JOINT POSITION |
| (4) SPACER 8" X 3-7/8" X 5/8"
[P/N 84-860858-003] GUTTER
JOINT POSITION - OUTSIDE
END LANE | (5) 1-1/2" RING SHANK NAIL | (6) DIVISION SUPPORT STRIP |
| (7) SPACER 14-1/2" X 3-7/8" X 5/8"
[P/N 84-860858-001]
NON-GUTTER JOINT POSITION | (8) SPACER 8" X 3-7/8" X 5/8"
[P/N 84-860858-003] GUTTER
JOINT POSITION - INSIDE
LANE DIVISION | (9) APPLY ADHESIVE |

Division Support Strip Installation

Preparation

If not previously done, remove and discard existing Tel-E-Foul castings, gutters, and capping. Remove any Nu-Wood or other shim materials that have been installed in the foundation at the division and ball returns.

Installation of Division Support Strips (inside division)

Using the same procedure that was used to install the ball return support frames (described earlier in this manual), install the division support. Refer to *Figure 12*.

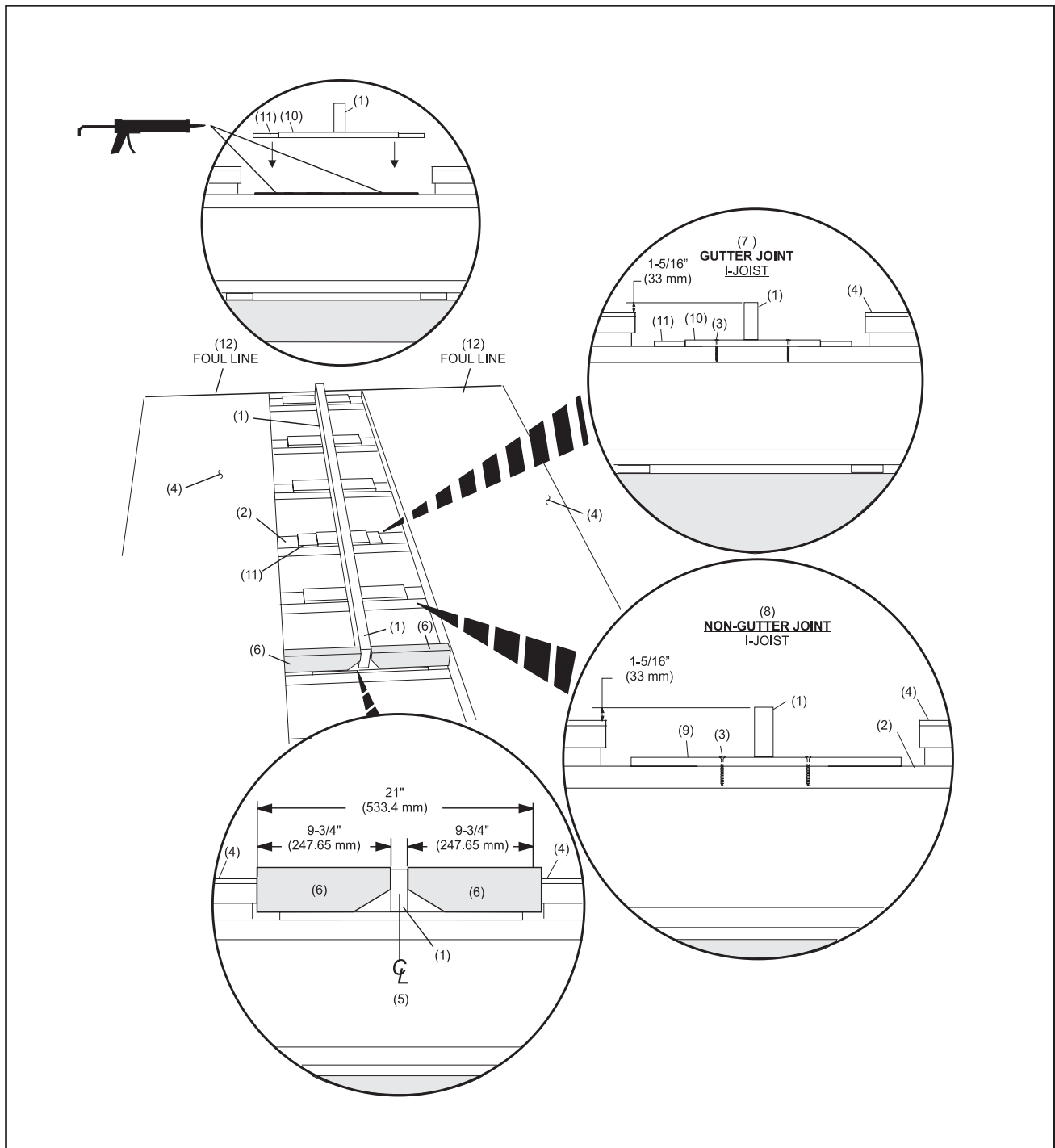

Figure 12. Install Division Support

- | | | |
|--|--|---|
| (1) DIVISION CAPPING SUPPORT STRIP | (2) FOUNDATION | (3) 2" ROBERTSON SCREW |
| (4) LANE | (5) DIVISION CENTER LINE | (6) CENTERING BLOCK |
| (7) GUTTER JOINT I-JOIST | (8) NON GUTTER JOINT I-JOIST | (9) NON-GUTTER JOINT SPACER
14.50" X 3-7/8 X 5/8"
[P/N 84-860858-001] |
| (10) GUTTER JOINT SPACER
8" X 3-7/8 X 5/8"
[P/N 84-860858-003] | (11) GUTTER JOINT SUPPORT SPACER
1/2" X 3-7/8" X 3-7/8" | (12) FOUL LINE |
| (13) 5/32" PILOT HOLE | (14) 9/32" CLEARANCE HOLE | |
| (16) 1/2" X 1-1/2" COUNTERBORE | (17) I-JOIST | |

Installation of Division Support Strips (Outside Lane)

Using the same procedure that was used to install the ball return support frames (described earlier in this manual), install the division support. Refer to *Figure 13*.

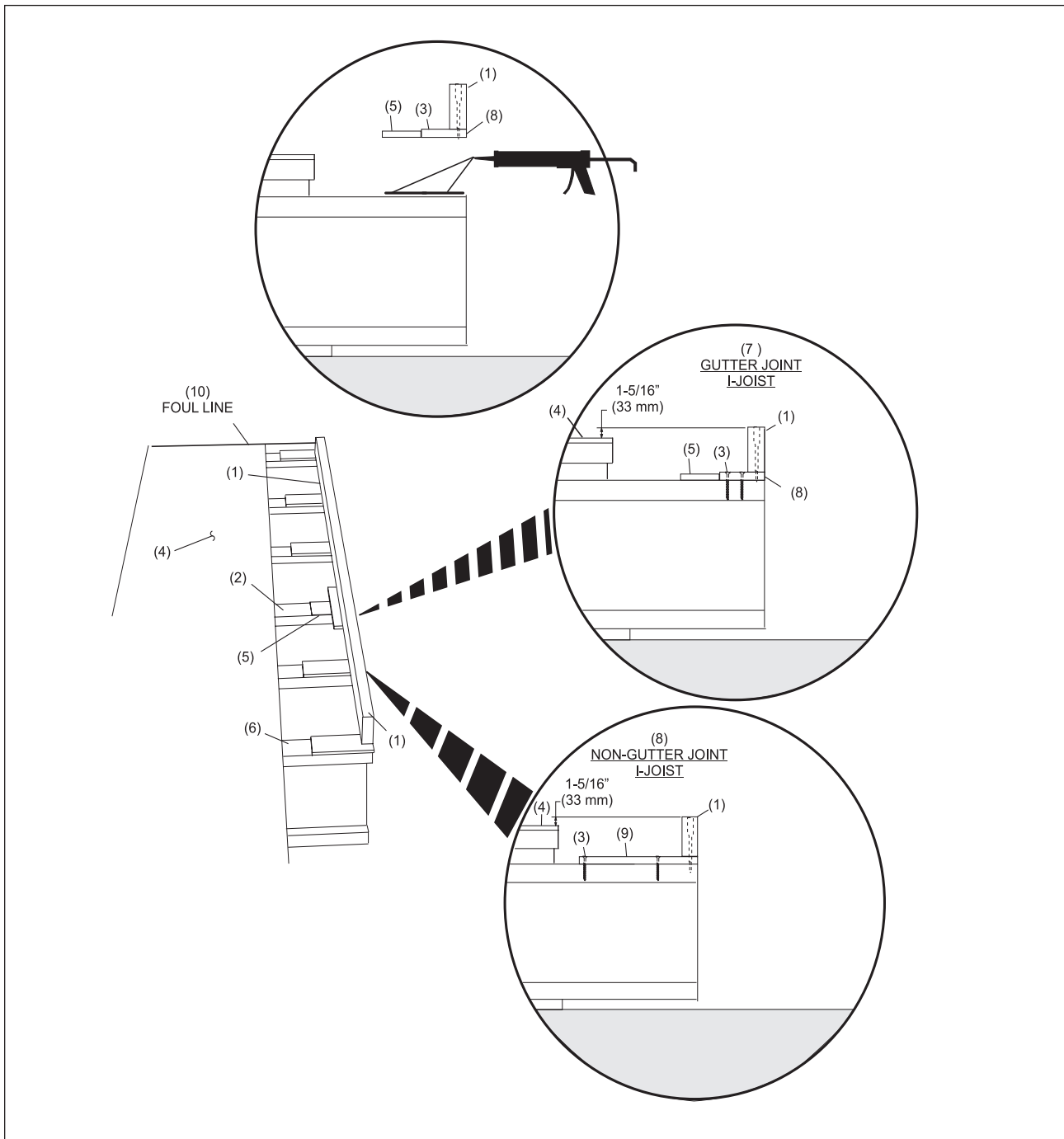

Figure 13. Install Division Support (outside division)

- | | | |
|------------------------------------|---|--|
| (1) DIVISION CAPPING SUPPORT STRIP | (2) FOUNDATION | (3) 2" ROBERTSON SCREW |
| (4) LANE | (5) GUTTER JOINT SPACER | (6) NON GUTTER JOINT I-JOIST |
| (7) GUTTER JOINT I-JOIST | (8) ROTATED GUTTER JOINT SPACER 8" X 3-7/8" X 5/8" (84-860858-003) | (9) NON GUTTER JOINT SPACER 8" X 3-7/8" X 5/8" [P/N 84-860858-003] |
| (10) FOUL LINE | (11) 5/32" PILOT HOLE | (12) 9/32" CLEARANCE HOLE |
| (13) #14 X 4" ROBERTSON SCREW | (14) 1/2 X 1-1/2" COUNTERBORE | (15) I-JOIST |

GUTTER JOINT SUPPORT BRACE INSTALLATION

i **NOTE:** If a gutter joint is centered between trusses, it may be necessary to install support brace(s).

Assemble and install gutter joint support braces for existing foundations as follows:

1. Measure the distance between the bottom of the installed gutter to the concrete floor. Refer to *Figure 14*.

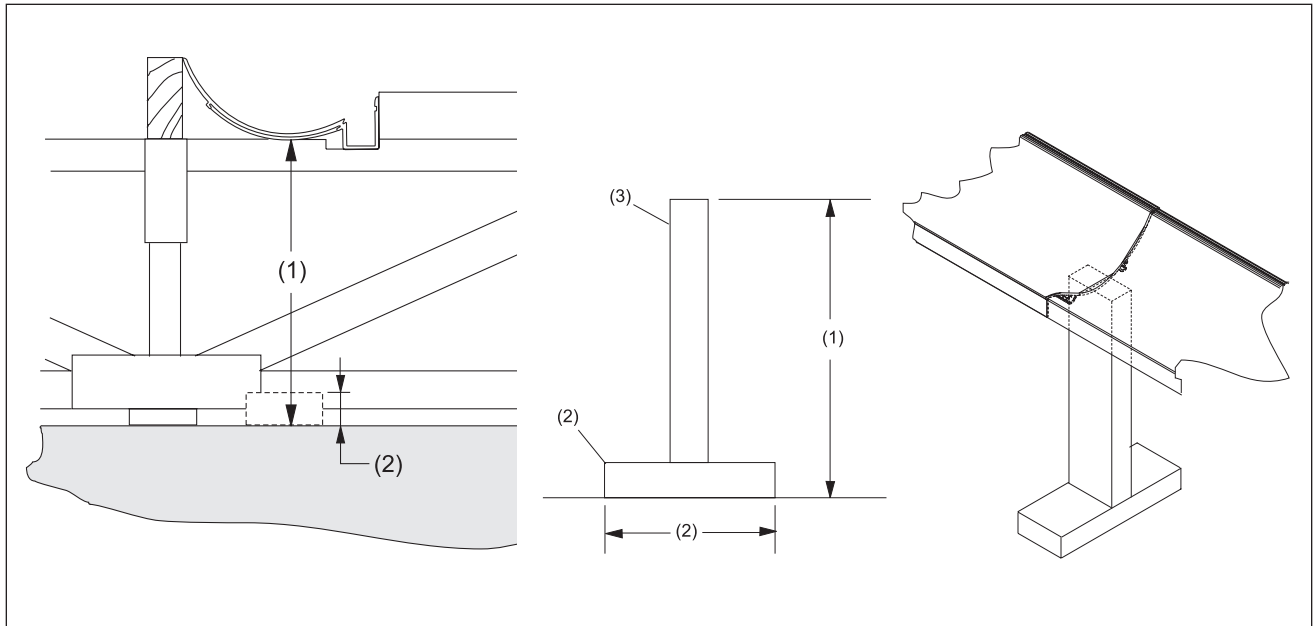

Figure 14. Gutter Joint Support Brace (If Required)

- | | | |
|--|---|-----------------------------|
| (1) MEASURE DISTANCE FROM FLOOR TO BOTTOM OF INSTALLED GUTTER AND SUBTRACT THICKNESS OF BASE 2 x 4 | (2) BASE 2 x 4 x 6" (152 mm) LENGTH MINIMUM | (3) LOCALLY PURCHASED 2 x 4 |
|--|---|-----------------------------|

2. Cut a 6" (152 mm) section from a locally purchased 2 x 4 board for the base.
3. Subtract the thickness of the base 2 x 4 from length noted in step 1 above and cut remaining section to this measurement for vertical piece.
4. Using screws or nails, assemble two boards together as shown in *Figure 20*.
5. Place assembled support brace directly centered beneath the gutter coupler.

GUTTER INSTALLATION

Existing Foundation

System B2000 Lane Surface - With Truss Foundation

1. Using a power router or equivalent tool, remove a 2-1/4" (57 mm) x 2-3/4" (70 mm) maximum depth section on top surface of truss, parallel with the outside edge of the lane. Refer to *Figure 15*.

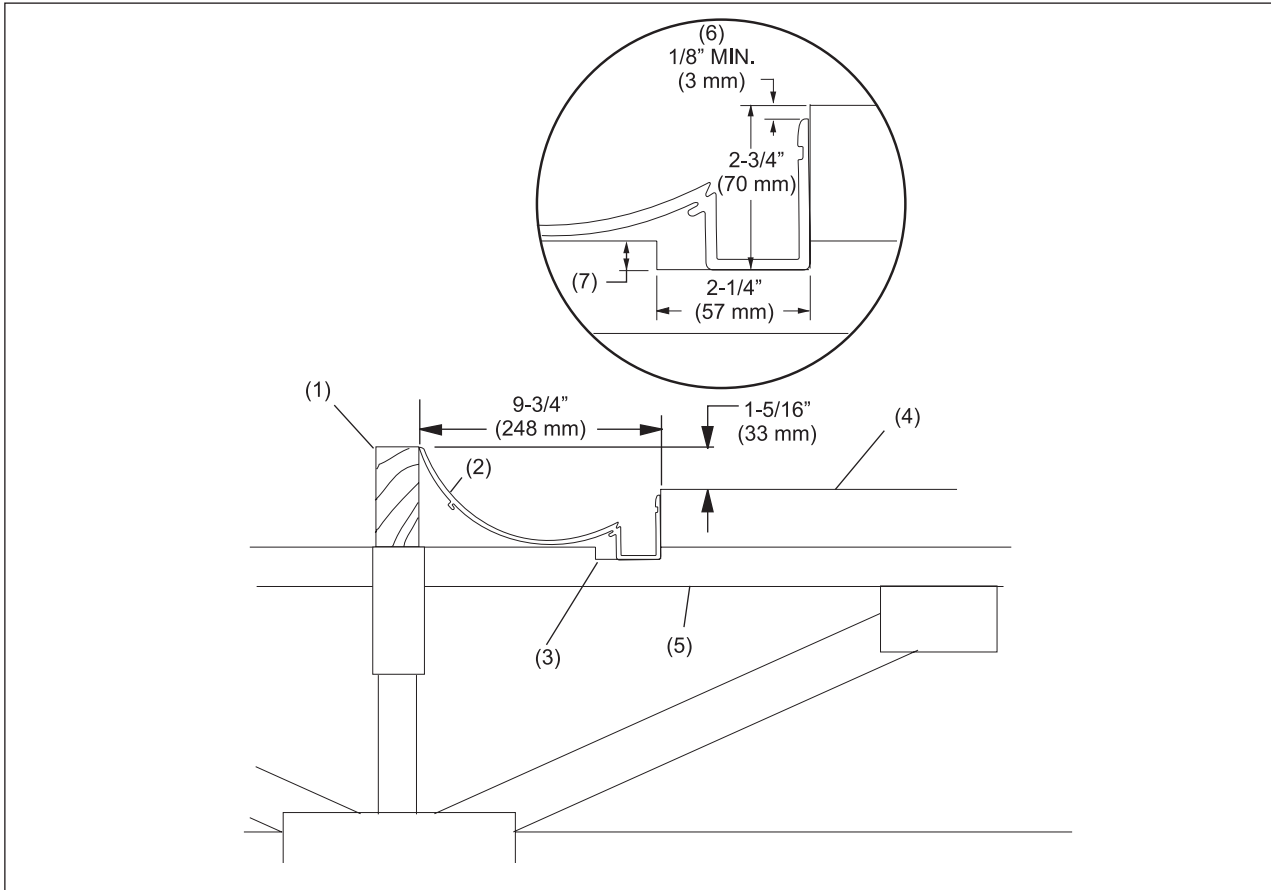

Figure 15. Route Top of Trusses as Required

- | | | |
|----------------------------|------------|-------------------------|
| (1) DIVISION SUPPORT STRIP | (2) GUTTER | (3) ROUTE AREA |
| (4) LANE SURFACE | (5) TRUSS | (6) 1/8" (3 mm) MINIMUM |
| (7) 3/4" (19 mm) MAXIMUM | | |



NOTE: Removing the surface area more than 3/4" (19 mm) deep on the top surface of the truss is not recommended. Upon placing gutter into routed area, the distance from the top of the gutter to the top of the lane surface should be 1/8" (3 mm) minimum for System B2000.

2. Remove any loose wood chips or dust from routed area.

New Foundation

Pinball Wizard gutters (P/N 84-860660-xxx left hand gutter (P/N 84-860661-xxx) right hand gutter) are manufactured with the numbers 1-8 placed on the end of them. These numbers identify the order and position of gutters regarding installation for a single lane.

1. Beginning with the L.H. foul line gutter, place the gutter section into position starting at the foul line and working toward the pin deck and repeat steps for the R.H. foul line gutter. Place the remaining three sections of gutter into position. Check for minimum distance of 1/4" (6.35 mm) from top of gutter to top of lane surface. Refer to *Figure 16*.

i **NOTE:** *New foundation/lane requires no modification.*

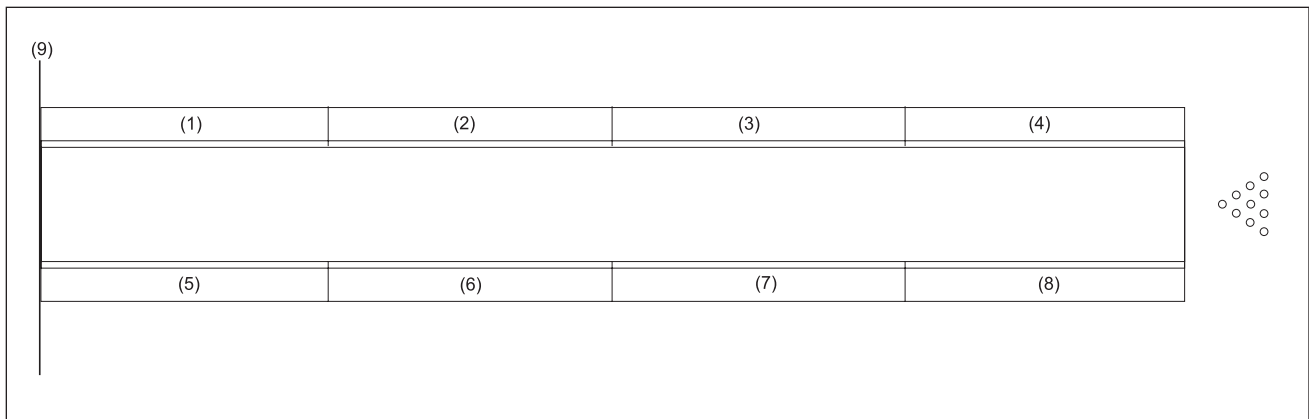

Figure 16. Gutter Location Stickers

- | | | |
|---------------------------|---------------------------|------------------------|
| (1) L.H. FOUL LINE GUTTER | (2) L.H. COMMON GUTTER | (3) L.H. COMMON GUTTER |
| (4) L.H. PINSETTER GUTTER | (5) R.H. FOUL LINE GUTTER | (6) R.H. COMMON GUTTER |
| (7) R.H. COMMON GUTTER | (8) R.H. PINSETTER GUTTER | (9) FOUL LINE |

i **NOTE:** *DO NOT screw gutters into place at this time.*

- Slide a gutter coupler (P/N 84-200462-000) into the foul line end of the fourth gutter section and carefully insert into groove of third gutter section. **Make sure joint has step down toward the pindeck.** Refer to *Figure 17*.

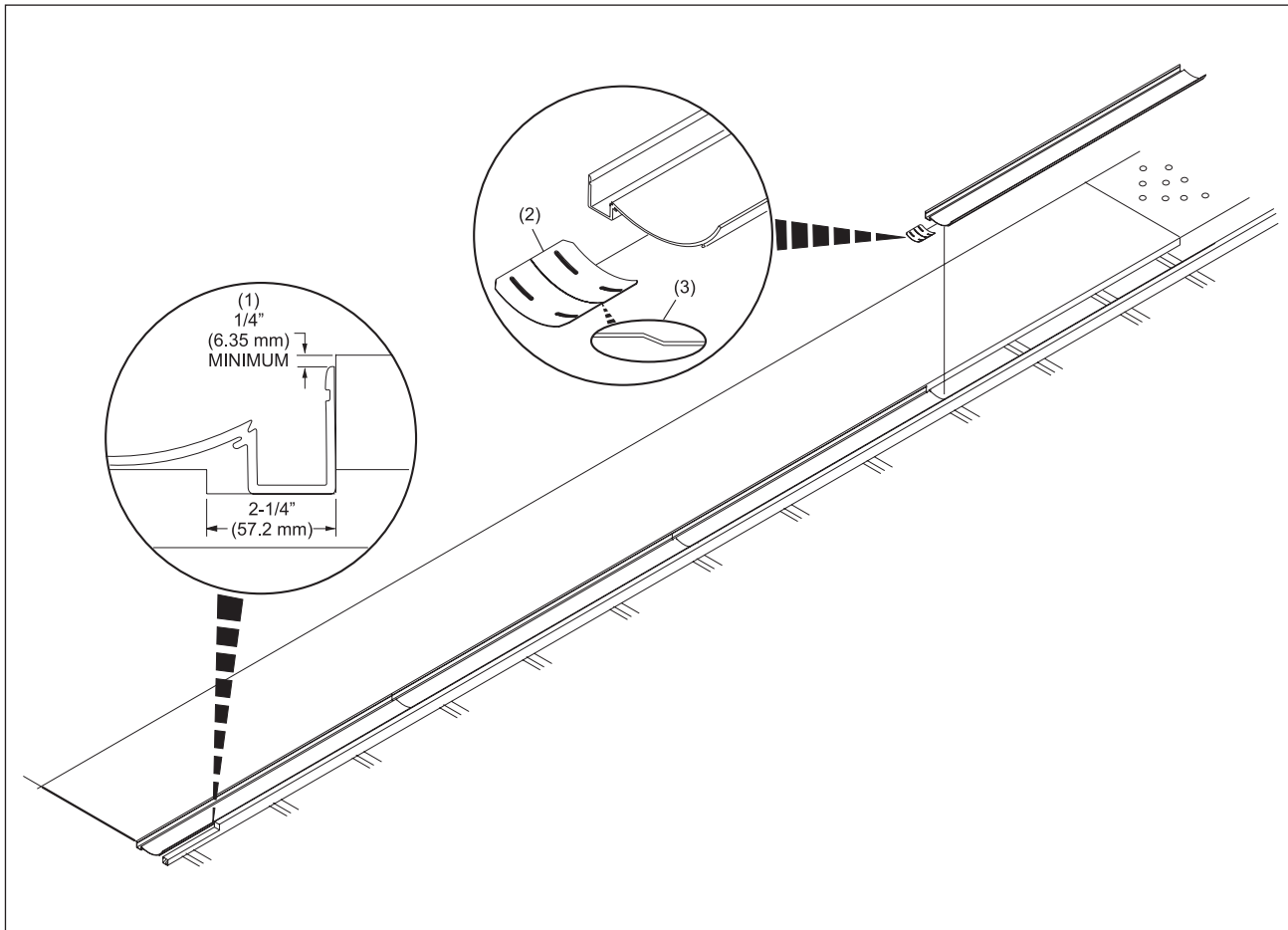

Figure 17. Place New Gutter Into Position

(1) 1/4" (6.35 mm) MINIMUM

(2) GUTTER COUPLER

(3) INSTALL COUPLER WITH
DOWNWARD BEND TOWARD
PIT END

i **IMPORTANT:** To ensure proper and consistent ball travel toward the pit end of the lane, a step down (higher to lower) condition **MUST** exist at every gutter joint.

i **IMPORTANT:** The design of the gutter coupler assists in maintaining a step-down condition however, additional support at **EVERY** joint is needed. Locally purchased material should be used to support the foul line half of the gutter couplers. Supports may extend from existing trusses, anchor strip, etc. or from the floor to the bottom of the couplers but must not interfere with ball return or automation components. This is not required on new foundations

3. Cut to fit the pit end of the fourth gutter section to accommodate the transition (flat gutter) block (P/N 84-200456-000) and kickback. Refer to *Figure 18*.

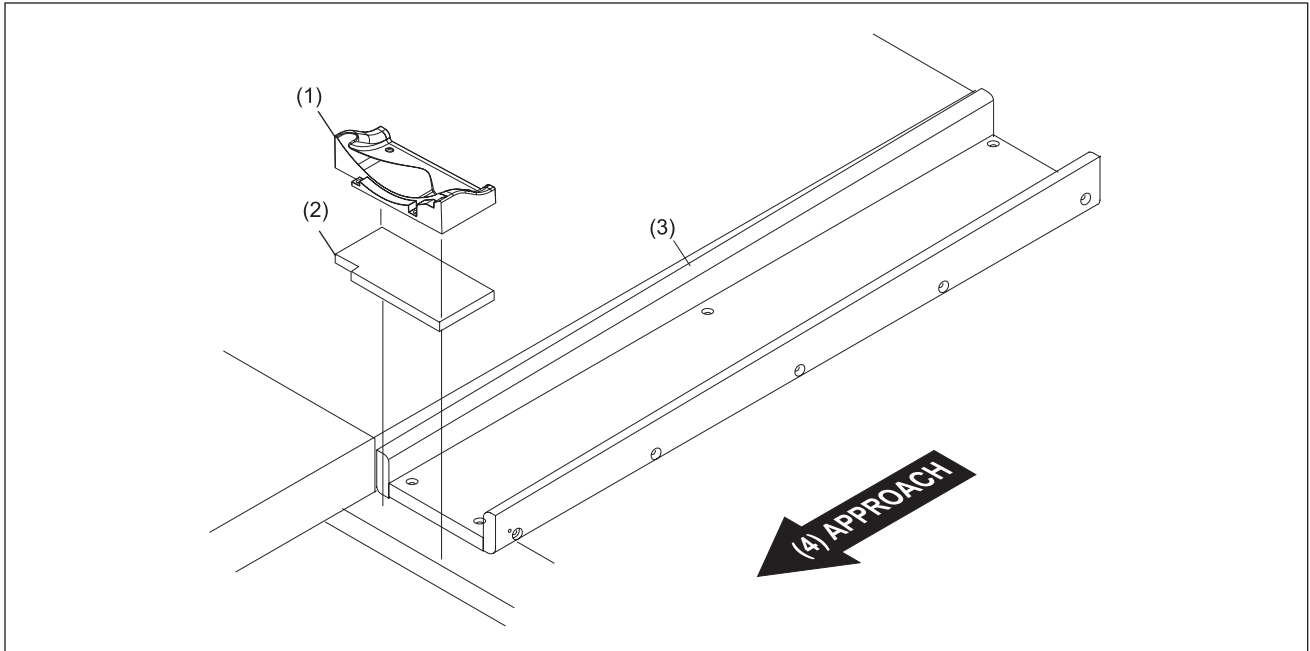

Figure 18. Install Flat Gutters

- | | | |
|------------------------|------------|-----------------|
| (1) TRANSITION BLOCK | (2) SPACER | (3) FLAT GUTTER |
| (4) APPROACH DIRECTION | | |

4. Install flat gutter spacer (P/N 84-200556-000, part of package number 84-860621-000) against pit end of gutter (notch in wood spacer toward the lane). Secure spacer with wood 2-1/2" screws. Refer to *Figure 18*.

5. Install transition block onto pit end of the fourth gutter section.
6. With all four gutter sections in place and transition block installed, use #10 x 1-1/2" Robertson screws (P/N 11-081201-000) to attach the THIRD and FOURTH sections ONLY!!!! Refer to *Figure 19*.

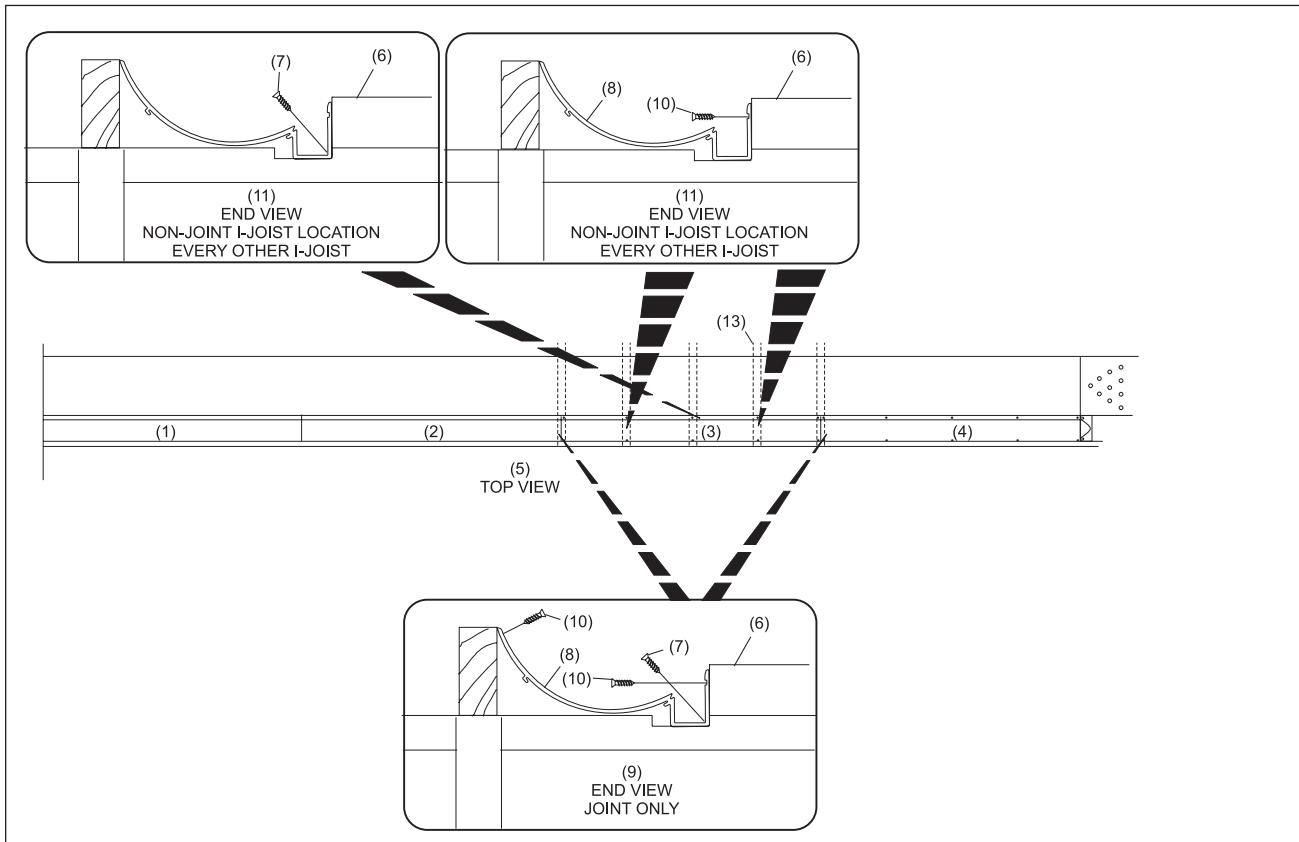

Figure 19. Attach Third and Fourth Sections of Gutter

- | | | |
|------------------------|--|--|
| (1) FIRST GUTTER | (2) SECOND GUTTER | (3) THIRD GUTTER |
| (4) FOURTH GUTTER | (5) TOP VIEW | (6) LANE |
| (7) DIAGONAL SCREW | (8) GUTTER | (9) END VIEW (GUTTER JOINT ONLY) |
| (10) HORIZONTAL SCREW | (11) END VIEW NON-JOINT I-JOIST LOCATION | (12) END VIEW NON JOINT I-JOIST LOCATION |
| (13) I-JOIST LOCATIONS | DIAGONAL SCREW EVERY OTHER I-JOIST | HORIZONTAL SCREW EVERY OTHER I-JOIST |

STAND-ALONE (COSMETIC) COVERS INSTALLATION

Included in package 84-860622-700 are covers (cosmetic strips) which cover the opening between the gutter and the lane edge, running the entire length of the lane.

1. Snap the cosmetic cover (118" length, P/N 84-200467-xxx) into place along the lane edge. Each side of lane requires four covers. Refer to *Figure 20*.

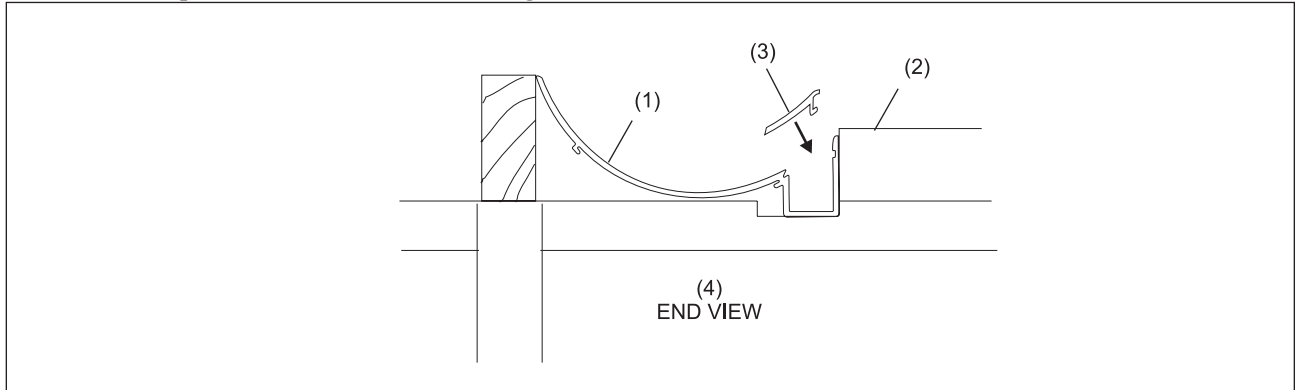

Figure 20. Install Cosmetic Covers

(1) GUTTER
(4) END VIEW

(2) LANE

(3) 118" LONG COVER

BALL RETURN CAPPING - NEW AND EXISTING FOUNDATIONS

Layout Capping Clips

1. Place 5" (127 mm) capping clip on top of support frame 2" (51 mm) from ball return kickbacks.

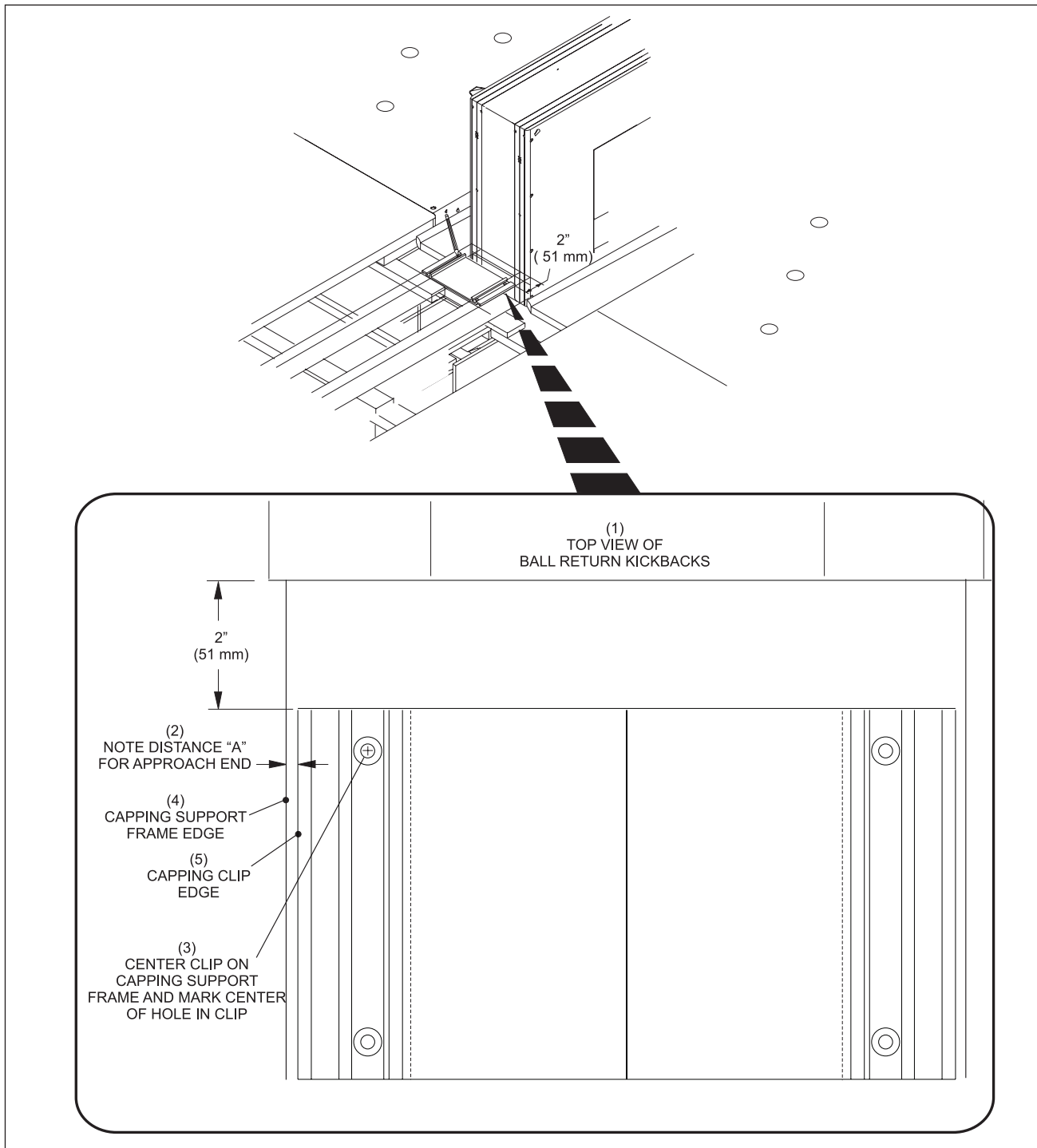

Figure 21. Ball Return Capping Clip

- | | | |
|---------------------------------------|--|--|
| (1) TOP VIEW OF BALL RETURN KICKBACKS | (2) NOTE DISTANCE "A" FOR APPROACH END | (3) CENTER CLIP ON CAPPING SUPPORT FRAME AND MARK CENTER OF HOLE IN CLIP |
| (4) CAPPING SUPPORT FRAME EDGE | (5) CAPPING CLIP EDGE | |

2. Center capping clip on capping support creating equal distance between the clip edges and the outside edges of the capping support Frame. Refer to *Figure 22*.
3. Mark center of hole closest to kickback on the left hand side and note the distance between the outside edge of the clip and the outside edge of the support frame (dimension "A").
4. Place 2-1/2" (64 mm) capping clip on top of support frame APPROXIMATELY 10" (254 mm) from foul line and use dimension "A" to locate left edge of capping clip from edge of support structure.

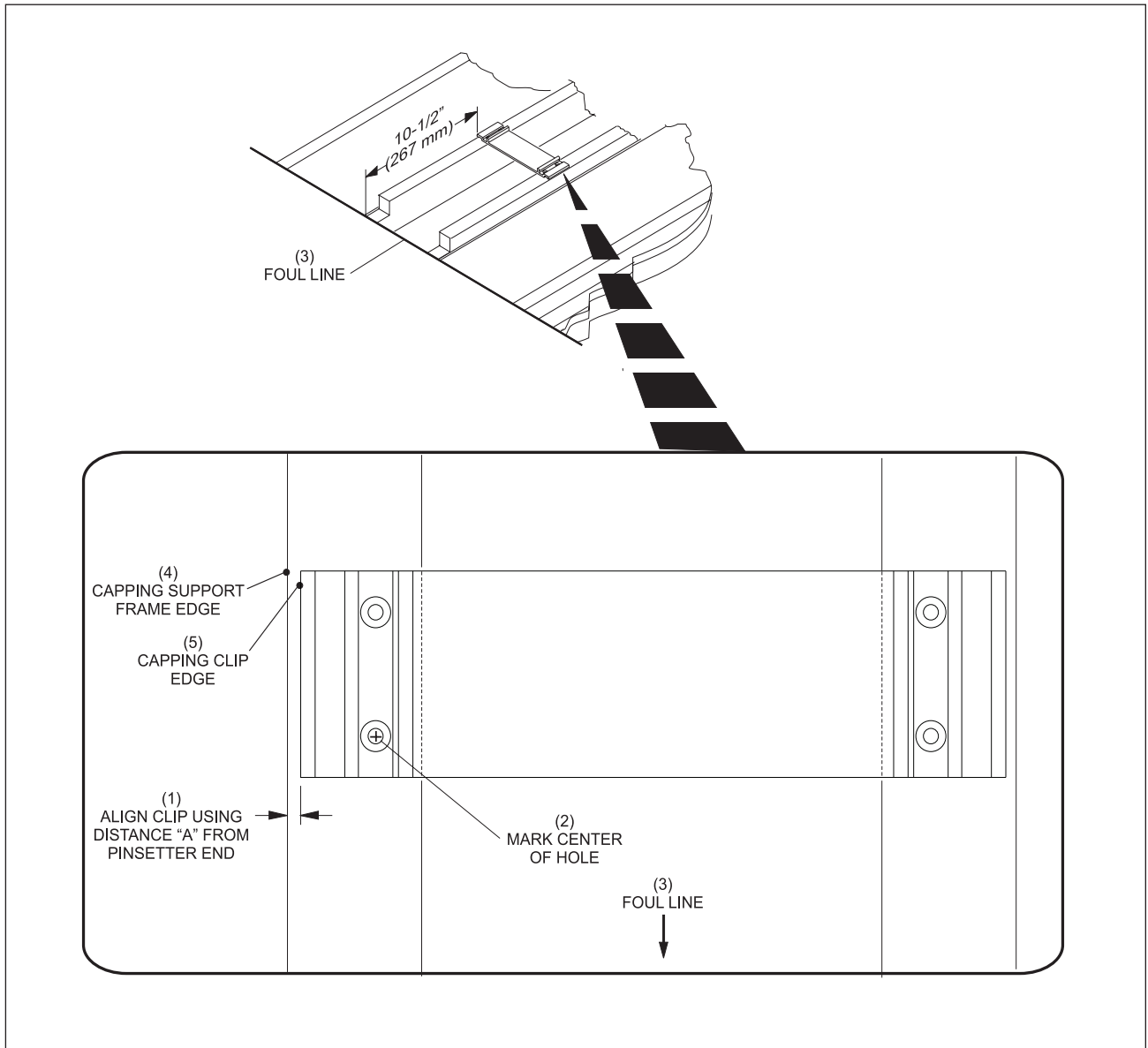

Figure 22. *Layout Approach End of Support Frame*

- | | | |
|--|-------------------------|---------------|
| (1) ALIGN CLIP USING DISTANCE "A" FROM PINSETTER END | (2) MARK CENTER OF HOLE | (3) FOUL LINE |
| (4) CAPPING SUPPORT FRAME EDGE | (5) CAPPING CLIP EDGE | |

5. Hammer a nail partially into the support frame on the marked locations at the pinsetter end and the approach end. Refer to *Figures 23 and 24*.

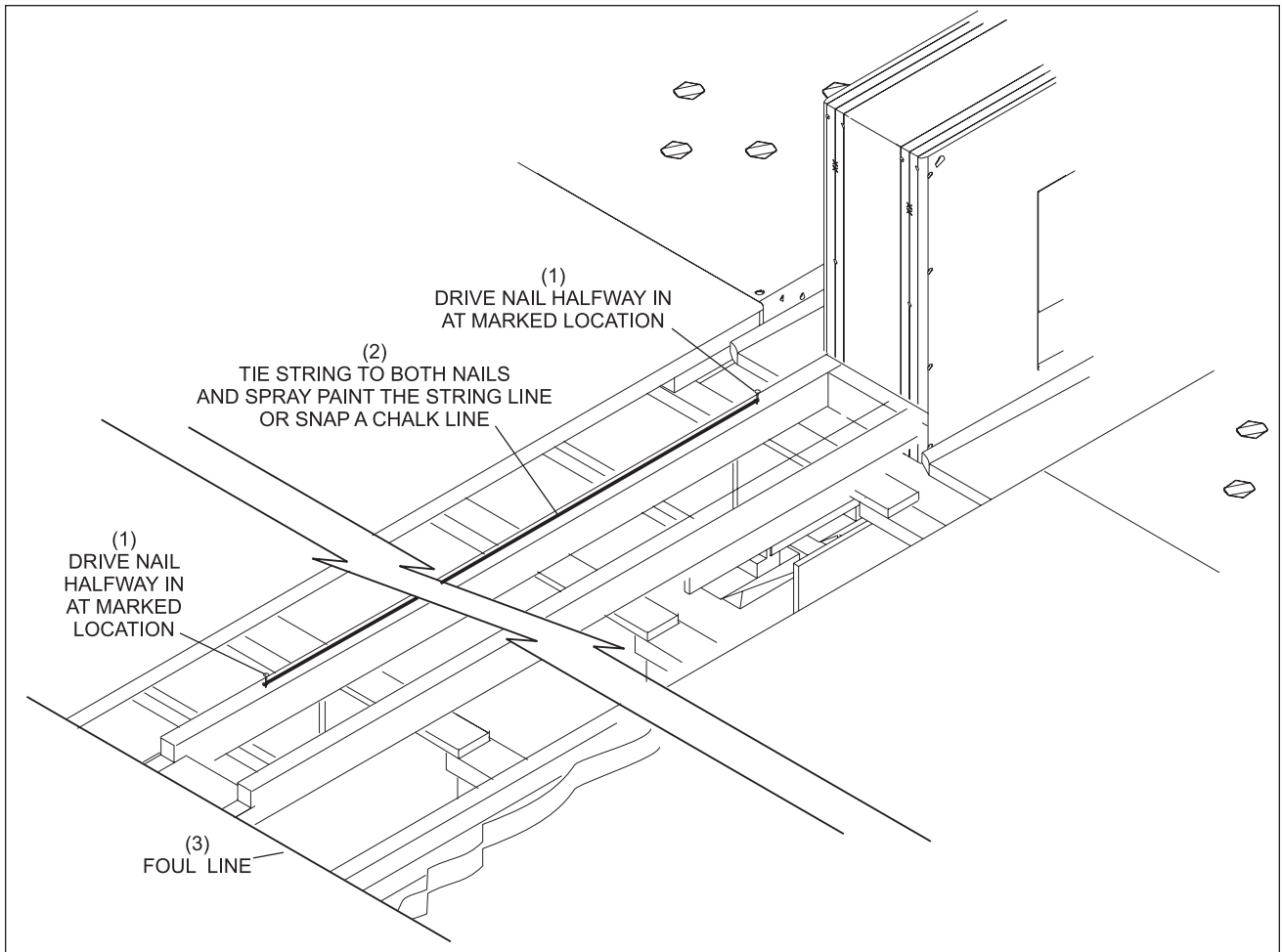

Figure 23. Mark Capping Support

- | | |
|---|--|
| (1) DRIVE NAIL HALFWAY IN AT MARKED LOCATIONS | (2) TIE STRING TO BOTH NAILS AND SPRAY PAINT LINE OR SNAP CHALK LINE |
|---|--|

6. Tie string between nails on support frame and spray paint a line or use a chalk line to snap a line. Refer to *Figure 23*.

Install Capping Clips

1. Install the additional capping clips as shown in *Figures 24 and 25*.

i **NOTE:** There must be a 5" (127 mm) capping clip (P/N 84-200240-000) centered at each ball return capping joint between each section of ball return capping.

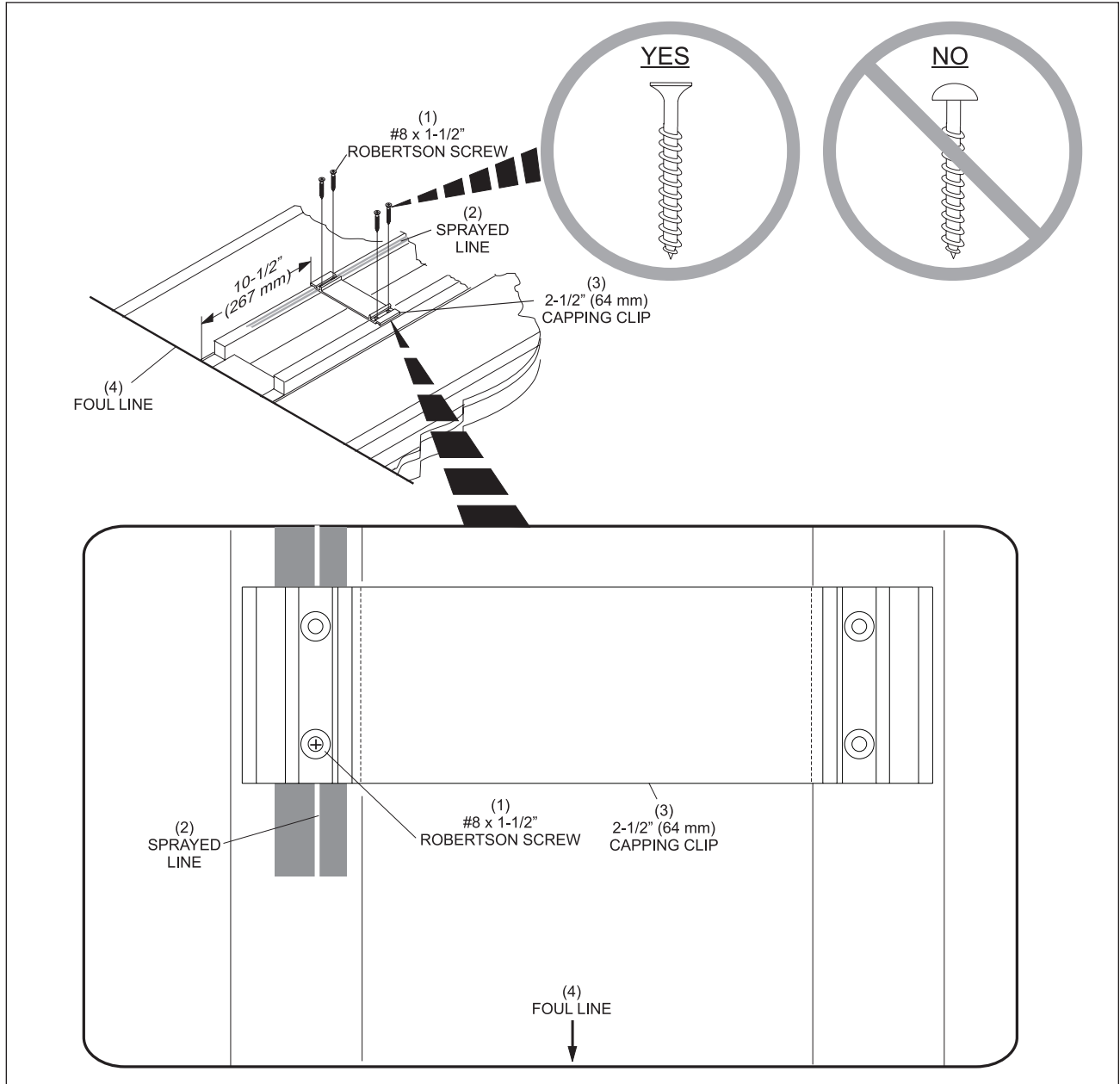

Figure 24. Clip Installation

- | | | |
|---------------------------------|------------------|---------------------------------|
| (1) #8 X 1-1/2" ROBERTSON SCREW | (2) SPRAYED LINE | (3) 2-1/2" (64 MM) CAPPING CLIP |
| (4) FOUL LINE | | |



CAUTION! The use of a brad nail gun to quickly position the clips is not recommended. Doing so may cause the capping clip to crack. Use only the correct screws illustrated in Figure 24.

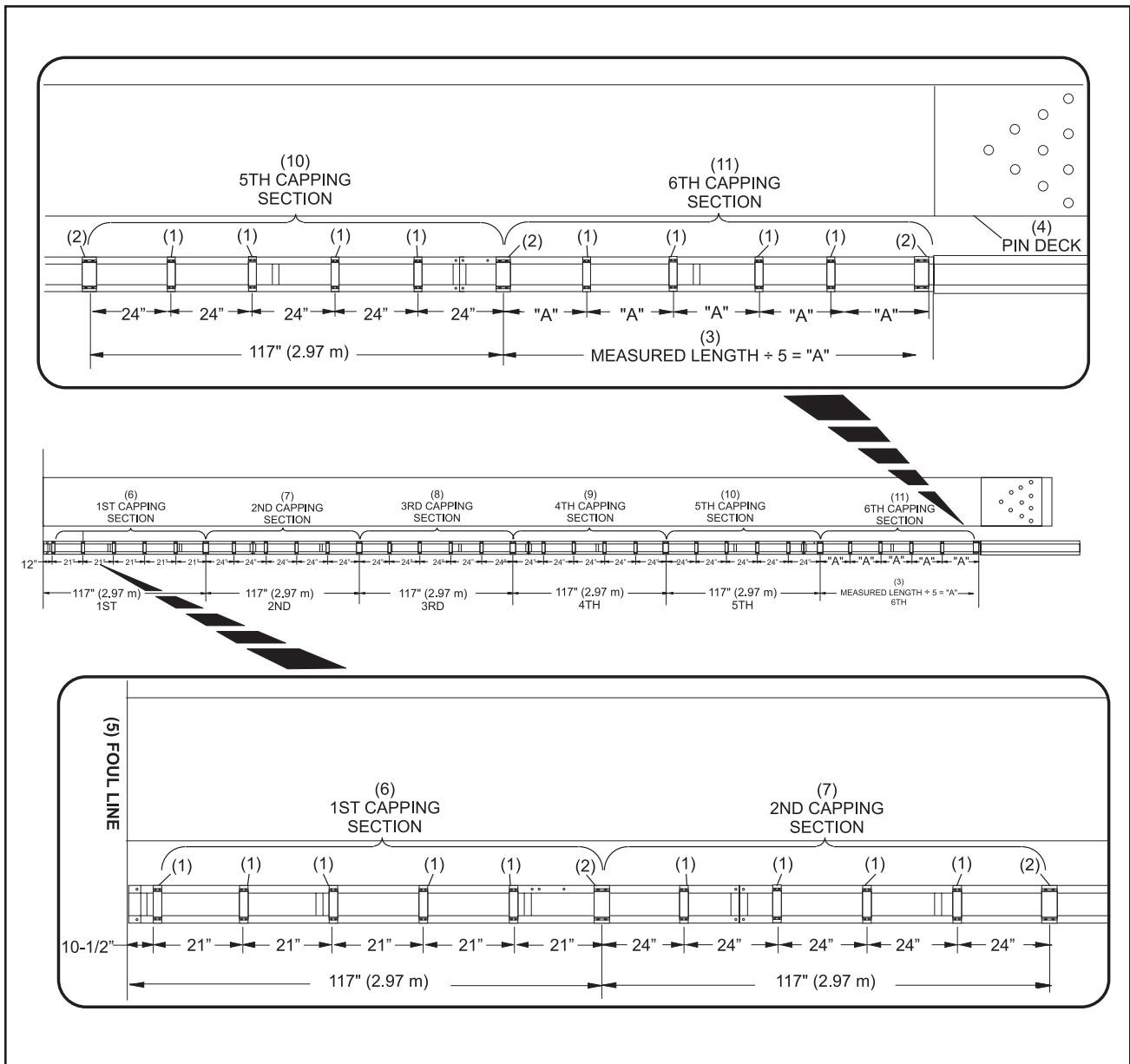

Figure 25. Clip Placement

- | | | |
|--------------------------------|------------------------------|---|
| (1) 2-1/2"(64 MM) CAPPING CLIP | (2) 5" (127 MM) CAPPING CLIP | (3) MEASURED LENGTH DIVIDED BY 5
INSTALL AT CAPPING JOINTS
EQUALS "A" 6TH CAPPING SECTION |
| (4) PIN DECK | (5) FOUL LINE | (6) 1ST CAPPING SECTION |
| (7) 2ND CAPPING SECTION | (8) 3RD CAPPING SECTION | (9) 4TH CAPPING SECTION |
| (10) 5TH CAPPING SECTION | (11) 6TH CAPPING SECTION | |

Ball Return Capping

1. Install the first section of ball return capping 10" (254 mm) from the approach end of the lane.
 - a. Align the capping section with the ears on the capping clip. Snap the capping into place. Continue this procedure toward the pin deck. Refer to *Figure 26*.

i **NOTE:** Ball return capping overhangs clip by 2" (51 mm) toward approach to allow for cover mounting tab.

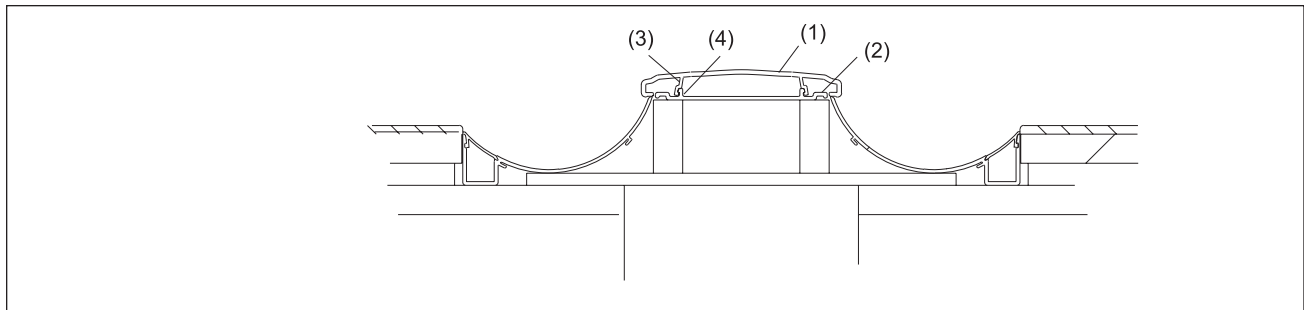

Figure 26. Snap Capping Into Place

- (1) BALL RETURN CAPPING (2) CAPPING CLIP (3) CAPPING EAR
(4) CLIP EAR

- b. Cut the last piece of capping to the required length, and snap it into place.

i **NOTE:** At centers with "A" or "A-2" pinsetters, it will be necessary to cut section of capping for kickback and foul line side of dropsweep hood.

i **NOTE:** At AMF centers, it will be necessary to cut a hole in the capping for the dropsweep. Use the original capping to determine the required size and location of the clearance hole.

Ball Return Cover

1. Center the ball return cover on the ball return capping. Refer to *Figure 27*.

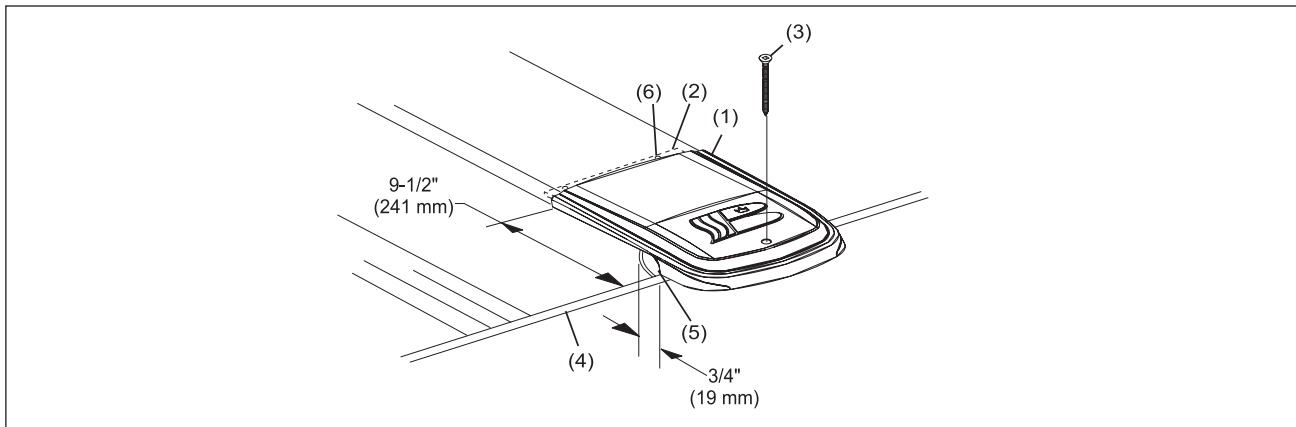

Figure 27. Ball Return Cover Installation

- | | | |
|-----------------------|--|--|
| (1) BALL RETURN COVER | (2) REAR COVER MOUNTING TAB | (3) #14 X 3-1/2" FLAT HEAD SCREW |
| (4) FOUL LINE | (5) 3/4" (19 mm) NOTCH FOR TEL-E-FOUL SIGNAL | (6) SECURE REAR COVER MOUNTING TAB WITH TWO #10 X 1-1/2" ROBERTSON SCREWS. |

2. Mark the location of the countersunk hole on the approach.
3. Remove the cover and drill a 5/32" hole approximately 1-3/4" deep at the marked location.

i **NOTE:** *On laminate lanes, drill a 1/4" diameter clearance hole through the laminate.*

4. Cut/notch a 3/4" (19 mm) clearance notch in the gutter to permit the Tel-E-Foul signal to pass from the Tel-E-Foul to the reflector.
5. Reposition the cover and secure it with a #14 x 3-1/2" flat head screw.
6. Remove capping and secure rear cover mounting tab with two #10 x 1-1/2" Robertson screws.

DIVISION CAPPING AND EXISTING FOUNDATION

Gutters at Division

Starting at the foul line, position all the gutters at each side of the division support strips using the same procedure that was used for gutters at the ball return. Refer to *Figure 8*.

i **NOTE:** Do not secure the gutter with screws at this time.

Division Capping

Install the division capping starting at 10-1/4" (260 mm) from the pinsetter side of the foul line.

1. Align the tabs on the division capping with the grooves in the gutter. Refer to *Figure 28*.

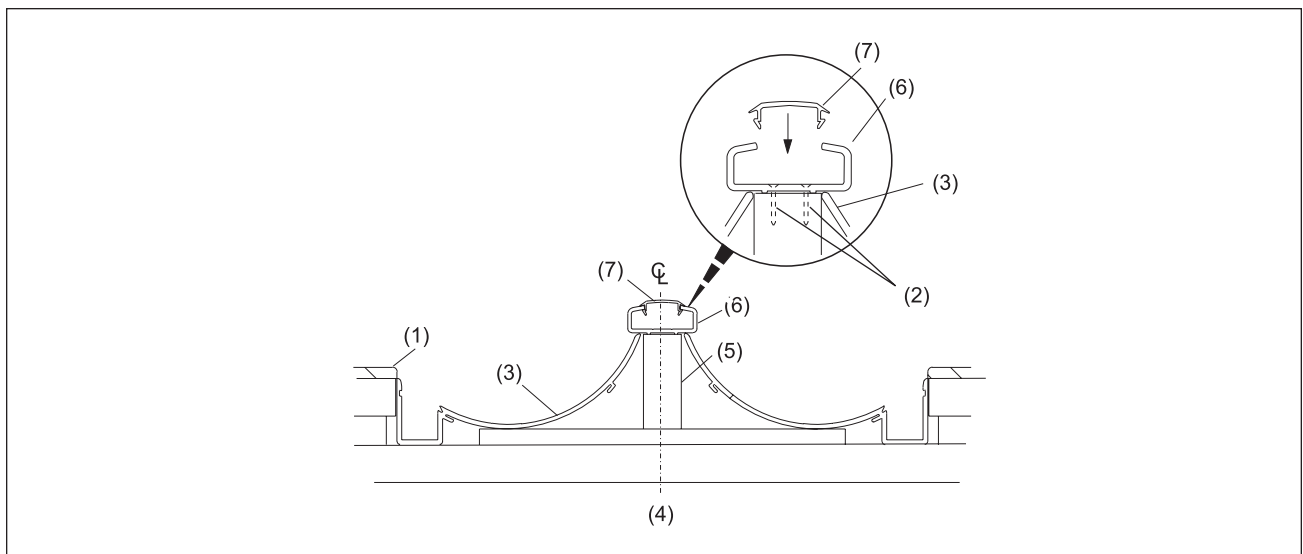

Figure 28. Align and Secure Capping to Support

- | | | |
|----------------------------|------------------------------------|----------------------|
| (1) LANE | (2) #8 X 1-1/4" HOLE CUTTING SCREW | (3) GUTTER |
| (4) CENTER LINE OF SUPPORT | (5) CAPPING SUPPORT | (6) DIVISION CAPPING |
| (7) COLOR STRIP | | |

i **NOTE:** The division capping must be centered in the opening between the lanes and tight against the Tel-E-Foul cover.

2. Secure the capping to the support with #8 x 1-1/4" hole cutting screws. Start approximately 1" (25 mm) from the foul line end of capping and install the screws side by side into grooves on 12" (305 mm) centers. Refer to *Figure 28*.
3. Cut the last section of capping as required to fit the opening at pit end.
4. Snap the color strip into the division capping.

Division Cover

1. Center the division cover on the division capping. Refer to *Figure 29*.

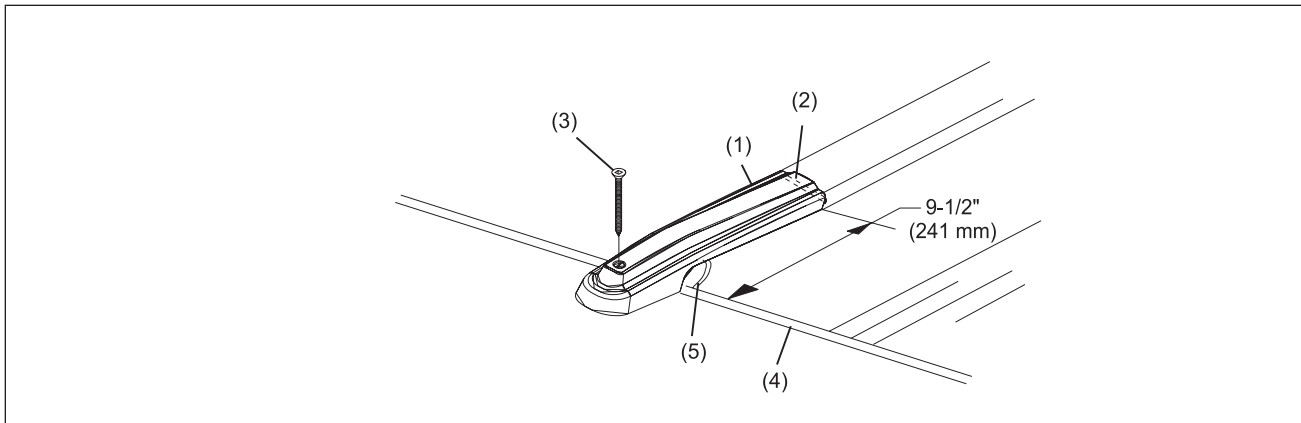

Figure 29. Install Division Cover

- | | | |
|--------------------|---------------------------------|---|
| (1) DIVISION COVER | (2) REAR SUPPORT | (3) #14 X 3-1/2" FLAT HEAD ROBERTSON SCREWS |
| (4) FOUL LINE | (5) NOTCH FOR TEL-E-FOUL SIGNAL | |

i **NOTE:** *Rear support is not secured to the support strip.*

2. Mark the location of the countersunk hole on the approach.
3. Remove the cover and drill a 5/32" hole approximately 1-3/4" deep at the marked location.

i **NOTE:** *On laminate lanes, drill a 1/4" diameter clearance hole through the laminate.*

4. Cut a clearance hole in the gutter to permit the Tel-E-Foul signal to pass from the Tel-E-Foul to the reflector. See Item 5, *Figure 29*.
5. Reposition the cover and secure it with a #14 x 3-1/2" flat head Robertson screw. Refer to *Figure 29*.

Ball Return Capping Removal

1. At the end of the ball return capping, step in the middle to flatten the ball return capping. Refer to *Figure 30*.

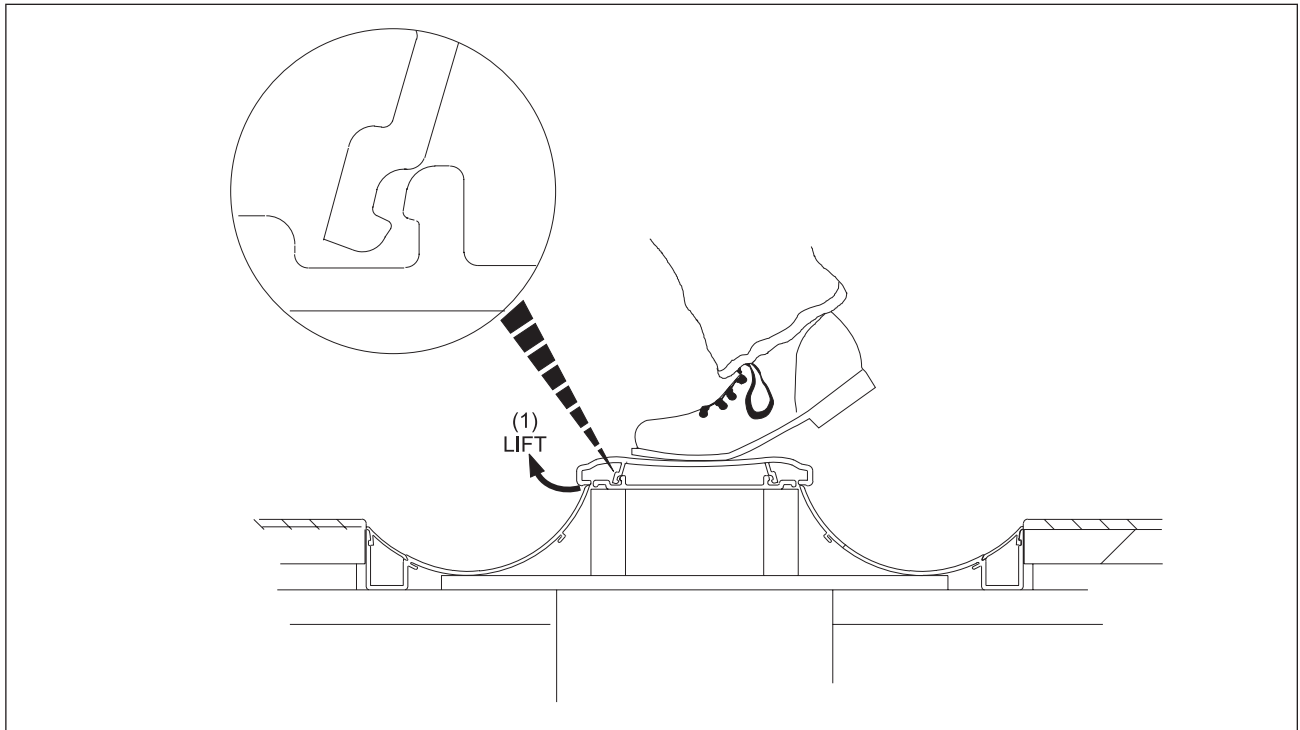

Figure 30. Flatten Ball Return Capping

2. Lift one side of the ball return capping off the clips. Once this side is loose from the clip push and lift the other side. Refer to *Figure 31*.

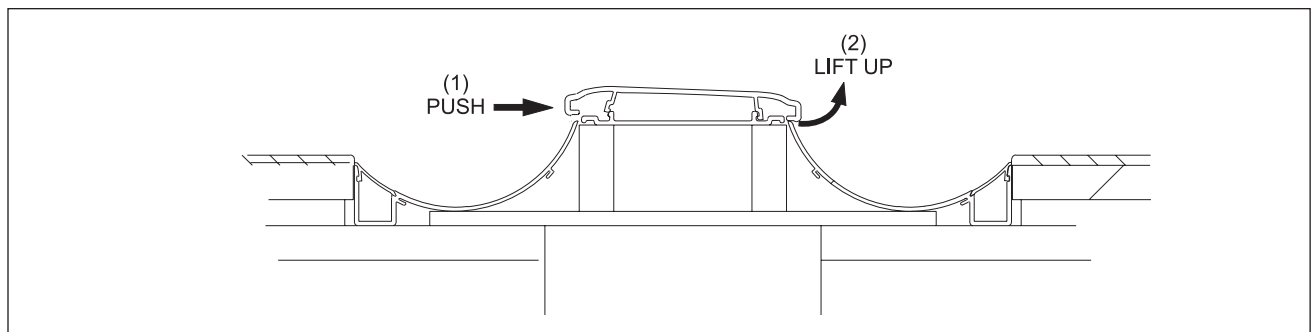

Figure 31. Lift One Side of Capping

(1) PUSH

(2) LIFT UP

3. Remove the ball return capping off the remaining clips by lifting one side of the ball return capping off then the other.