



**POLARIS**<sup>®</sup>  
The Way Out.

**2008**  
**SPORTSMAN 90**  
**OUTLAW 90**

**Owner's Manual**  
**for Maintenance and Safety**

## **⚠️ WARNING**

**Improper vehicle use can result in  
SEVERE INJURY or DEATH.**



**ALWAYS USE  
AN APPROVED  
HELMET AND  
PROTECTIVE  
GEAR**



**NEVER USE  
ON PUBLIC  
ROADS**



**NEVER CARRY  
PASSENGERS**



**NEVER USE  
WITH DRUGS  
OR ALCOHOL**

**READ OWNER'S MANUAL.  
FOLLOW ALL INSTRUCTIONS  
AND WARNINGS.**

Part No. 9921483 Rev 01  
PRINTED IN TAIWAN

**NEVER** operate:

- without proper training or instruction
- at speeds too fast for your skills or the conditions
- on public roads - a collision can occur with another vehicle
- with a passenger - passengers affect balance and steering and increase risk of losing control

**ALWAYS:**

- use proper riding techniques to avoid vehicle overturns on hills and rough terrain and in turns
- avoid paved surfaces - pavement may seriously affect handling and control



**POLARIS**  
The Way Out.®

**⚠ WARNING**

The engine exhaust from this product contains chemicals known to the State of California to cause cancer, birth defects or other reproductive harm.

A card containing important ATV safety information should be attached to the owner's manual on the next page. If you cannot locate this card, or if it has been removed, please call 1-800-342-3764 for assistance.

Visit us at [www.polarisindustries.com](http://www.polarisindustries.com)



POLARIS and POLARIS THE WAY OUT are registered trademarks of Polaris Industries Inc.

Copyright 2007 Polaris Sales Inc. All information contained within this publication is based on the latest product information at the time of publication. Due to constant improvements in the design and quality of production components, some minor discrepancies may result between the actual vehicle and the information presented in this publication. Depictions and/or procedures in this publication are intended for reference use only. No liability can be accepted for omissions or inaccuracies. Any reprinting or reuse of the depictions and/or procedures contained within, whether whole or in part, is expressly prohibited.

Printed in USA

2008 Outlaw 90/Sportsman 90 ATV Owner's Manual

P/N 9921483

## Dear Parents:

We believe your children should have the opportunity to enjoy The Way Out experience along with you. We've provided this owner's manual to assist you and your children in learning about safe operation and care of your new ATV. Please review the information in this manual with any child who may operate the ATV. Help your children learn to operate the ATV with safety as a top priority. Help them also learn to show respect for our environment and for the rights of others while operating the ATV.

Children differ in skills, physical abilities and judgement. Some children may not be able to operate an ATV safely. Always supervise your child's use of the ATV, and permit continued use only if you determine that your child has the ability and maturity to operate the ATV safely. Never allow a child to operate the ATV without adult supervision.

The preventive maintenance program outlined in this manual is designed to ensure that all critical components on your child's ATV are thoroughly inspected at various intervals. For safe and enjoyable operation of the vehicle, be sure to follow all of the instructions and recommendations in this manual. If you have any questions about the ATV, contact a Polaris dealer for assistance.

# **Welcome**

## **Dear Children:**

Before you ride your new Polaris ATV, there are some important things that you need to know. Your parents and Polaris want you to enjoy riding your new ATV, and that's why you need to read and understand the information in your owner's manual.

Ask your parents to explain anything you don't understand, and pay close attention to the warnings and instructions you read. Your safety and the safety of others is the most important thing to think about at all times.

As the driver of the ATV, you must learn how to keep yourself and those around you safe while you're riding. So read your manual, and then enjoy riding your new Polaris ATV!

## Table of Contents

<b>Safety</b> . . . . .	<b>6</b>	<b>Adult Section</b> . . . . .	<b>33</b>
<b>Youth Section</b> . . . . .	<b>17</b>	Safety Decals . . . . .	34
Know Your ATV . . . . .	18	Driver Warnings . . . . .	43
Pre-Ride Check . . . . .	25	Vehicle ID Numbers . . . . .	66
Riding Rules . . . . .	28	Features and Controls . . . . .	67
		Break-in Period . . . . .	83
		Pre-Ride Inspections . . . . .	85
		Starting the Engine . . . . .	88
		Stopping the Engine . . . . .	91
		Driving Safely . . . . .	92
		Emission Control . . . . .	112
		Maintenance . . . . .	114
		Specifications . . . . .	178
		Polaris Products . . . . .	182
		Troubleshooting . . . . .	184
		Warranty . . . . .	190
		Maintenance Log . . . . .	198
		<b>Index</b> . . . . .	<b>202</b>



# Safety

## Understand the Warnings

Always follow the age guidelines for your ATV. Never allow a younger child to ride on or drive the ATV. Make sure all operators have completed an approved ATV safety training course such as the SVIA *RiderCourse*<sup>sm</sup> and understand all warnings and the owner's manual before driving the ATV.

## Know Your ATV Before Riding

Parents must help their children learn the proper and safe way to ride an ATV. Read the owner's manual with your children before starting the engine for the first time, and review it with them periodically afterwards.

## Safety Training

ATV safety training is a top priority for Polaris. When you purchased your new ATV, your dealer instructed you on the authorized *ATV RiderCourse*<sup>sm</sup> available to you and your eligible family members. This training is included in the purchase price of your ATV. Polaris strongly encourages you and your age eligible family members who will be riding the ATV to take the *ATV RiderCourse*<sup>sm</sup>.

In addition, you were provided with printed material and a video or DVD that instructs operators on safe operating procedures. You should review this information with your child on a regular basis.

If you purchased a used Polaris ATV, you can take the *ATV RiderCourse*<sup>sm</sup> by calling ATV Enrollment Express at (800) 887-2887 or by visiting [www.atvsafety.org](http://www.atvsafety.org). Purchasers of a used Polaris ATV will be charged for this training.

## Safety

The following signal words and symbols appear throughout this manual and on your vehicle. Your safety is involved when these words and symbols are used. Become familiar with their meanings before reading the manual.



The *safety alert symbol*, on your vehicle or in this manual, alerts you to the potential for injury.

### **WARNING**

The *safety alert warning* indicates a potential hazard that may result in serious injury or death.

### **CAUTION**

The *safety alert caution* indicates a potential hazard that may result in minor injury or damage to the vehicle.

### **CAUTION**

A *caution* indicates a situation that may result in damage to the vehicle.

### **NOTE:**

A *note* will alert you to important information or instructions.

### **WARNING**

Failure to follow the warnings in this manual can result in severe injury or death.

A Polaris ATV is not a toy and can be hazardous to operate. This vehicle handles differently than other vehicles such as motorcycles and cars. A collision or rollover can occur quickly, even during routine maneuvers like turning, or driving on hills or over obstacles, if you fail to take proper precautions.

Read and understand the owner's manual and all warnings before operating a Polaris ATV.

## Safety

- Read this manual and all labels carefully. Follow all operating procedures.
- Never operate an ATV without proper instruction. *Take a training course.* Purchasers of a new Polaris ATV and age eligible family members are entitled to take the *ATV RiderCourse<sup>sm</sup>*. Contact ATV Enrollment Express at (800) 887-2887 or visit [www.atvsafety.org](http://www.atvsafety.org) for information on enrollment in the *ATV RiderCourse<sup>sm</sup>*.
- Always follow the age guidelines for your vehicle: Y-12 90cc models are designed for children not less than 12 years of age and Y-6 50cc models are designed for children not less than 6 years of age. No child under the age of 16 should ride any ATV designed and sold for an adult.
- Do not allow other children to ride this ATV unless they have read the manual, seen the instructional video or DVD and taken and completed an approved ATV safety training course such as the *ATV RiderCourse<sup>sm</sup>*.
- Always avoid operating an ATV on any paved surfaces, including sidewalks, driveways, parking lots and streets.
- Never operate an ATV on any public street, road or highway, including dirt or gravel roads.
- Always be sure there are no obstacles or people behind your ATV when operating in reverse. Drive slowly and avoid turning at sharp angles in reverse.

## Safety

- Never operate an ATV without wearing an approved helmet that fits properly. Always wear eye protection (goggles or face shield), gloves, boots, a long-sleeved shirt or jacket, and long pants.
- Never consume alcohol or drugs before or while operating this ATV.
- Never operate at excessive speeds. Always travel at a speed which is proper for the terrain, visibility and operating conditions, and your experience.
- Never attempt jumps or other stunts.
- Never tow or pull an object behind the ATV.
- Always inspect your ATV each time you use it to make sure it is in safe operating condition. Always follow the inspection and maintenance procedures and schedules described in this manual.
- Always keep both hands on the handlebars and both feet on the footrests of the ATV during operation.
- Always go slowly and be extra careful when operating on unfamiliar terrain. Always be alert to changing terrain conditions when operating the ATV.
- Never operate on excessively rough, slippery or loose terrain.

## Safety

- Always follow proper procedures for turning as described in this manual. Practice turning at low speeds before attempting to turn at faster speeds. Do not turn at excessive speed.
- Always have the ATV checked by an authorized Polaris dealer if it has been involved in an accident.
- Never operate the ATV on hills too steep for the ATV or for your abilities. Practice on smaller hills before attempting larger hills.
- Always follow proper procedures for climbing hills as described in this manual. Check the terrain carefully before you start up any hill. Never climb hills with excessively slippery or loose surfaces. Shift your weight forward. Never open the throttle suddenly or make sudden gear changes. Never go over the top of any hill at high speed.
- Always follow proper procedures for going down hills and for braking on hills as described in this manual. Check the terrain carefully before you start down any hill. Shift your weight backward. Never go down a hill at high speed. Avoid going down a hill at an angle which would cause the vehicle to lean sharply to one side. Go straight down the hill where possible.

## Safety

- Always follow proper procedures for crossing the side of a hill as described in this manual. Avoid hills with excessively slippery or loose surfaces. Shift your weight to the uphill side of the ATV. Never attempt to turn the ATV around on any hill until you have mastered the turning technique described in this manual on level ground. Avoid crossing the side of a steep hill.
- Always use proper procedures if you stall or roll backwards when climbing a hill. To avoid stalling, maintain a steady speed when climbing a hill. If you stall or roll backwards, follow the special procedure for braking described in this manual. Dismount on the uphill side or to either side if pointed straight uphill. Turn the ATV around and remount, following the procedure described in this manual.
- Always be careful of skidding or sliding. On slippery surfaces, such as ice, go slowly and be very cautious in order to reduce the chance of skidding or sliding out of control.



## Safety

- Always check for obstacles before operating in a new area. Never attempt to operate over large obstacles, such as rocks or fallen trees. Always follow proper procedures when operating over obstacles as described in this manual.
- Avoid operating the ATV through deep or fast flowing water. If you cannot avoid water which exceeds the recommended maximum depth (see page 106), go slowly, balance your weight carefully avoiding sudden movements, maintain a slow and steady forward motion, do not make sudden turns or stops, and do not make sudden throttle changes.
- Wet brakes may have reduced stopping ability. Test your brakes after leaving water. If necessary apply them lightly several times to let friction dry out the pads.
- Always use the size and type tires specified in this manual. Always maintain proper tire pressure as described in this manual.
- Never modify an ATV through improper installation or use of accessories.
- Never exceed the stated load capacity for an ATV.
- Always remove the ignition key when the vehicle is not in use to prevent unauthorized use or accidental starting.

**FOR MORE INFORMATION ABOUT ATV SAFETY, call the Consumer Product Safety Commission at 1-800-638-2772, or Polaris at 1-800-342-3764.**

## Equipment Modifications

We are concerned for the safety of our customers and for the general public. Therefore, we strongly recommend that consumers do not install on a Polaris ATV any equipment that may increase the speed or power of the vehicle, or make any other modifications to the vehicle for these purposes. Any modifications to the original equipment of the vehicle create a substantial safety hazard and increase the risk of bodily injury.

The warranty on your Polaris ATV is terminated if any equipment has been added to the vehicle, or if any modifications have been made to the vehicle, that increase its speed or power.

**NOTE:** The addition of certain accessories may change the handling characteristics of the ATV. Use only Polaris-approved accessories, and familiarize yourself with their function and effect on the ATV.



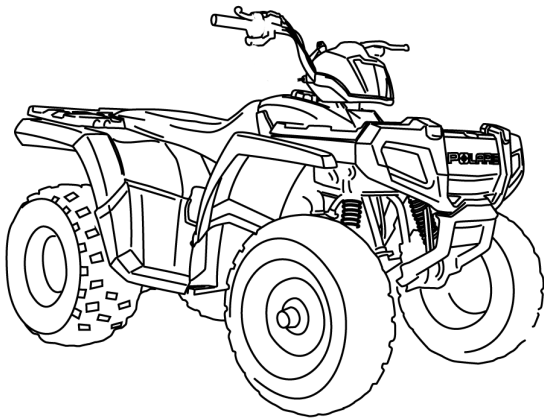

# Youth Section

## Know Your ATV

**PARENTS:** Polaris Youth ATVs are equipped with a speed control system to allow adults to limit the speed of the vehicle for the rider's skill and experience. More information on speed limiting functions can be found beginning on page 142.

These units are not designed for adult use. Serious damage to the vehicle may occur if the maximum rider weight capacity is exceeded. See the specifications section beginning on page 178 for your ATV's capacity.

**CHILDREN:** Before you ride your new Polaris ATV, there are some important things that you need to know. Your safety and the safety of others is the most important thing to think about at all times. As the driver of the ATV, you must learn how to keep yourself and those around you safe while you're riding.

Pay attention when you see this symbol:



This is the safety alert symbol. When you see this symbol on your ATV or in this manual it means **PAY ATTENTION** because you could die or be seriously injured if you don't follow the instructions.

## Know Your ATV

Before you have an adult start the engine for you for the first time, let's learn about the controls on your new ATV.

1. **Engine Stop Switch** - When the engine is running, push this button down to shut the engine off quickly. The button must be up before you can start the engine again.
2. **Horn Button** - Press the horn button to sound the horn.
3. **Throttle Control** - Press the throttle lever with your thumb when you want the ATV to go forward. Always make sure the throttle control does not stick before you drive your ATV. Read more about it on page 25.

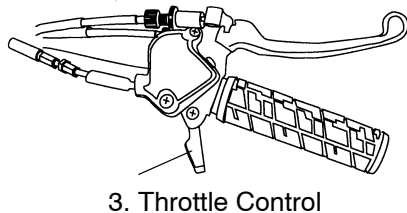
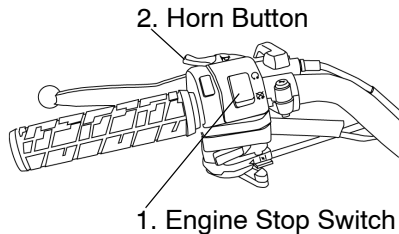

## Know Your ATV

4. **Kick-Start Lever** - If your battery is too weak to start your ATV, you can push down on the kick-start lever with your foot to start the engine. Have an adult show you how it works. Read more about how to use the kick-start on page 82.
5. **Shift Lever** - The shift lever is on the right side of your ATV. Read about how to use the shift lever on page 72.

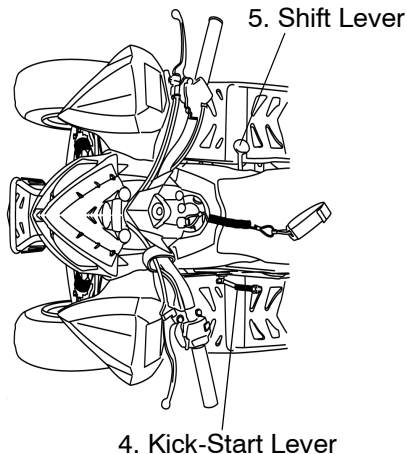

## Know Your ATV

- Gas Cap** - The gas cap has to be taken off when an adult puts gas in your ATV. Never take the gas cap off. Always make sure it's tightly closed.



Always have an adult put gas in your ATV. Never try to do it yourself.

- Seat Latch** - The seat latch is under the left edge of the seat. Reach under the left rear fender and pull back on the latch to remove the seat. To replace the seat, set it in place and push down on the seat above the latch. Always make sure the seat is locked in place before riding.

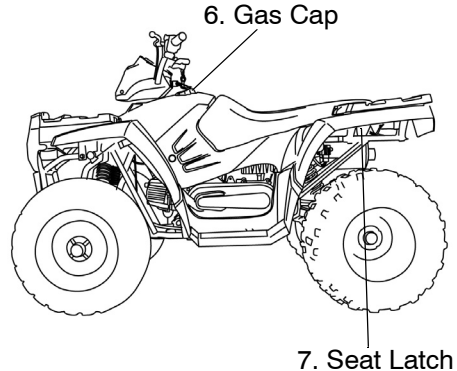



## Know Your ATV

8. **Brake Levers** - Squeeze the brake levers toward the handlebar to slow down or stop the ATV. The left lever controls the rear brake. The right lever controls the front brake. Always squeeze both brake levers at the same time.



Always squeeze both brake levers at the same time or you could lose control of the ATV and be seriously injured. Always take your thumb off the throttle lever when you squeeze the brake levers.

8. Rear Brakes

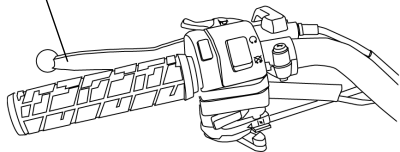

8. Front Brakes

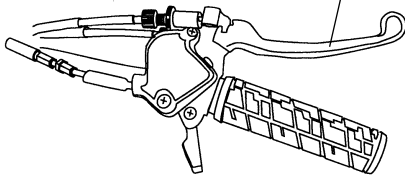

## Know Your ATV

- 9. Ignition Switch** - The ignition switch key must be turned on before pushing the starter button. You can also use this key to turn off the engine.
- 10. Tether Strap and Switch** - The tether strap must always be attached snugly to your right wrist and to your ATV every time you drive. If you fall off your ATV, the tether strap will pull away from the switch and the engine will stop.

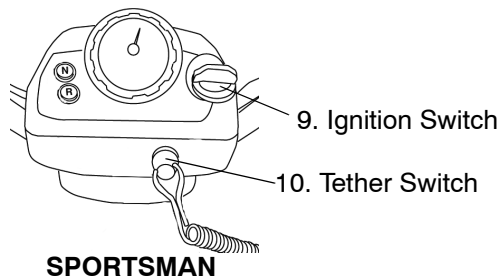
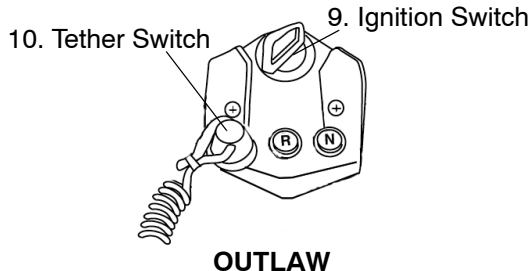

Never ride without the tether strap attached to your right wrist and to your ATV. Be careful not to let the cord get tangled around the handlebars or any part of your body.

## Know Your ATV

Let's review the three ways to stop the engine of your ATV:

1. Push the engine stop switch down.
2. Pull the tether strap off the ATV.
3. Turn the key off.



## Pre-Ride Check

We're almost ready to have an adult start your ATV. But before the ATV is started for the first time, you must do a Pre-Ride Check. In fact, every time you want to ride you must have an adult help you check some things on your ATV before starting it. Let's learn about these things now.

- ✔ Make sure the throttle doesn't stick. Check this by pushing the throttle lever toward the handlebar and then letting go. The lever should come right back to where it was before you pushed it. If it comes back slowly or stays close to the handlebar, the ATV has a sticky throttle. This means that something is wrong or broken and must be fixed before you can ride your ATV safely.



Never start the engine if you have a sticky throttle. You could be seriously hurt if you ride with a sticky throttle. Have an adult or your Polaris dealer fix the throttle before you ride.

## Pre-Ride Check

- ✓ Make sure the brakes don't stick. Check the brake levers by squeezing them toward the handlebar and then letting go. They should come right back to where they were before you squeezed. If they go back slowly or stay close to the handlebar, your ATV has sticky brakes. They must be fixed before you can ride your ATV safely.



Never start the engine if your ATV has sticky brakes. You could be seriously hurt if you ride with sticky brakes. Have an adult or your Polaris dealer fix the sticky brakes before you ride.

- ✓ Have an adult check to see if your ATV needs more gas. Children must never add their own gasoline. This must always be done by an adult. Before anyone adds gasoline to your ATV they must read the instructions and warnings on page 78 of this manual.



Always have an adult put gas in your ATV. Never try to do it yourself.

## Pre-Ride Check

- ✔ If you used the storage area under the seat, make sure the seat is locked in place.
- ✔ Have an adult check the engine oil level when the engine is cold. The engine is very hot after it has been running and it can burn your skin if you touch it. Children must never check the oil on their own. An adult should always be in charge of keeping the gas and oil levels at the full marks.
- ✔ This last check is done with the engine running. You must check to make sure that all three ways to stop the engine of your ATV are working the way they should. Do you remember what they are? If you can't remember the three ways to stop the engine, go back to page 24 and review. Then have an adult help you start the engine. Practice stopping the engine all three ways.

## Riding Rules

Now you're ready to learn about riding your Polaris ATV. There are some things you can do and there are some things you must never do. Rules are very important when you're driving an ATV. Adults have riding rules, too. The rules help keep us safe when we ride.

- ▶ The adult with you is your teacher. Always pay attention to what your teacher says so you can learn how to always drive safely.

Let's learn how to ride!



Always follow the safe riding rules found on the next pages. You or others around you could be seriously hurt if you don't follow the safe riding rules.

## Riding Rules

- ▶ Always wear the right kind of clothing and safety gear when riding your ATV.

**Helmet:** Your helmet is very important for safe riding. A helmet can prevent a severe head injury.

**Eye Protection:** Always wear shatterproof goggles or a helmet face shield, and always keep them clean so you can see where you're driving.

**Gloves:** Wear gloves to protect your hands from sun and wind. Gloves will also protect your hands from scrapes and scratches.

**Boots:** Wear sturdy boots to keep your feet dry. Boots will also protect your feet and ankles from scrapes and scratches.

**Clothing:** Make sure your clothing fits properly. If it's too small, it could keep you from moving easily when you shift your weight. If it's too big, it could hang down and get caught in a moving part. Wear long sleeves and long pants to protect your arms and legs.

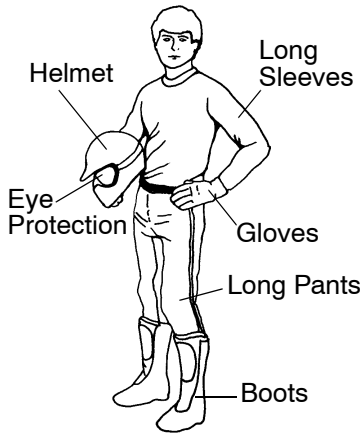



## Riding Rules

- ▶ Always attach the tether strap to your right wrist and to the ATV before riding.
- ▶ Make sure you know where you're going to drive before your ATV is started. Make sure the area is safe all around your ATV.
- ▶ Your ATV is made for one person. Never carry a passenger. A passenger will make the ATV harder to drive. You may lose control and hurt yourself and your passenger.
- ▶ Always drive your ATV while sitting down. Keep both hands on the handlebars and keep both feet on the footrests.
- ▶ Always be alert and pay attention to where you're driving. Pay attention to other drivers, and be even more careful around them because you don't know what they're going to do.
- ▶ Never follow another ATV too closely. You need lots of time and space to stop your ATV.
- ▶ Never tow or pull an object behind the ATV.



## Riding Rules

- ▶ Never ride alone. An adult should always be watching you in case you need help. Always drive within the sight of an adult.
- ▶ Never ride on public trails.
- ▶ Don't ride your ATV on roads or over railroad tracks. Your ATV makes noise that will keep you from hearing cars, trucks or trains that may be coming towards you.
- ▶ Don't ride at night. Your ATV doesn't have lights that are safe for driving in the dark.
- ▶ Learn where there are lakes, rivers, ponds and ditches in your driving area. Stay away from them.
- ▶ Never ride on frozen water. You could get hurt or you could even die. All ice can be dangerous!
- ▶ Ride your ATV only where you know it is safe to drive and where you have permission to drive. Be careful of the things around you.
- ▶ Always be a polite driver. (Don't drive through the flower garden or over the little trees you planted!)
- ▶ Always do your best to help take care of nature.

***Respect your ATV;  
respect your environment;  
and you will earn  
the respect of everyone.***

***Enjoy riding your new Polaris ATV!***

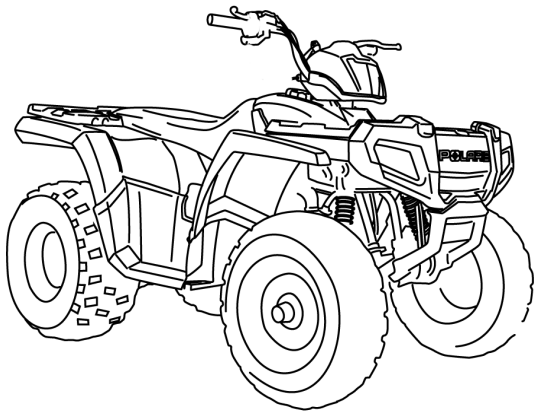

## **Adult Section**

## Safety Decals

Warning decals have been placed on the ATV for your protection. Read and follow the instructions on each decal carefully. If any of the decals shown in this manual differ from the decals on your ATV, always read and follow the instructions of the decals on the ATV.

If any decal becomes illegible or comes off, contact your Polaris dealer to purchase a replacement. Replacement *safety* decals are provided by Polaris at no charge. The part number is printed on the decal.

# Safety Decals

## Operation Warning

### WARNING

**Improper ATV use can result in SEVERE INJURY OR DEATH.**

Always use an approved helmet and protective gear. Never use on public roads. Never carry passengers. Never use with drugs or alcohol.

**NEVER** operate: without proper training or instruction; at speeds too fast for your skills or the conditions; on public roads - a collision can occur with another vehicle; with a passenger - passengers affect balance and steering and increase risk of losing control.

**ALWAYS** use proper riding techniques to avoid vehicle overturns on hills and rough terrain and in turns; avoid paved surfaces - pavement may seriously affect handling and control.

LOCATE AND READ OWNER'S MANUAL. FOLLOW ALL INSTRUCTIONS AND WARNINGS. IF OWNER'S MANUAL IS MISSING, CONTACT A POLARIS DEALER FOR A REPLACEMENT.

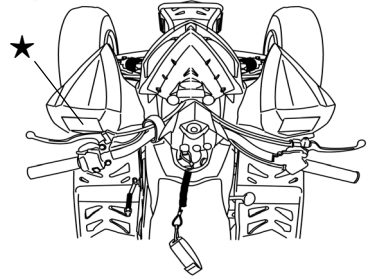

# Safety Decals

## Age Warning

### WARNING

- Kids under age 12 should NEVER operate this ATV. Kids under 12 have an increased chance of losing control, which could result in severe injury or death.
- Adult supervision is required.
- Make sure operators follow Owner's Manual and labels.
- Make sure operators watch the safety video or DVD and complete the *ATV RiderCourse*<sup>SM</sup>.
- Never operate this ATV on HILLS steeper than 15 degrees  $\leq 15^\circ$ . To prevent flipover on hilly terrain, use throttle and brakes gradually.
- REVERSE operation can be dangerous even at low speeds. Steering becomes difficult. To prevent flipover, avoid sudden braking or sharp turns.

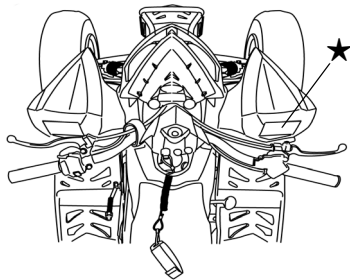

## Outlaw 90 Tire Pressure Warning

### WARNING

IMPROPER TIRE PRESSURE OR OVERLOADING can cause loss of control, resulting in SEVERE INJURY OR DEATH.

TIRE PRESSURE IN PSI (KPa): FRONT 3 (20.7)  
REAR 3 (20.7)

MAXIMUM WEIGHT CAPACITY (Gross Vehicle Weight) INCLUDING MACHINE, DRIVER AND CARGO IS 453 LBS. (206 KG).

## Safety Decals

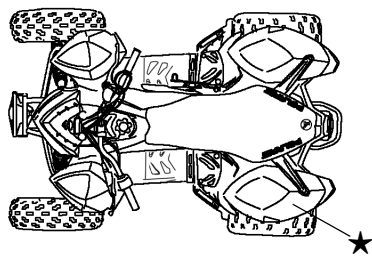



# Safety Decals

## Sportsman 90 Tire Pressure Warning

### WARNING

IMPROPER TIRE PRESSURE OR OVERLOADING can cause loss of control resulting in SEVERE INJURY OR DEATH.

TIRE PRESSURE IN PSI (KPa): FRONT 3 (20.7)  
REAR 3 (20.7)

MAXIMUM WEIGHT CAPACITY (Gross Vehicle Weight) INCLUDING MACHINE, DRIVER AND CARGO IS 528 LBS. (240 KG).

Reduce speed and allow greater distance for braking when carrying cargo. Overloading or carrying tall, off-center, or unsecured loads will increase your risk of losing control. Loads should be centered, carried as low as possible, and firmly secured to the racks. With dual racks, load distribution 1/3 front 2/3 rear is best. For stability on rough or hilly terrain, reduce speed and cargo. Be careful if load extends over the side of the rack.

Read Owner's Manual for more detailed loading information.

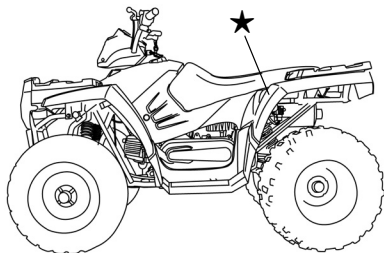

## Safety Decals

### No Passenger Warning

#### WARNING

NEVER ride as a passenger.

Passengers can cause a loss of control, resulting in SEVERE INJURY or DEATH.

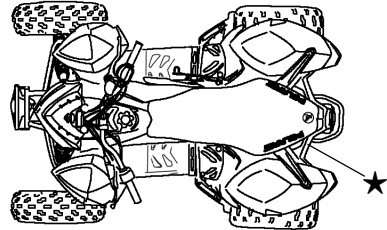
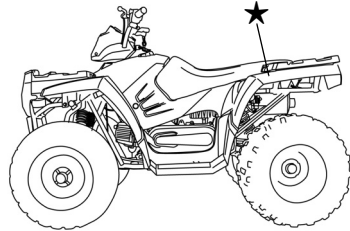

# Safety Decals

## Sportsman 90 Rack Warning

### WARNING

DO NOT TOW WITH THIS VEHICLE.

Vehicle damage or tipover may result causing severe injury or death.

Maximum Rack Loads: Front 15 lbs. (6.8 kg)  
Rear 30 lbs. (13.6 kg)

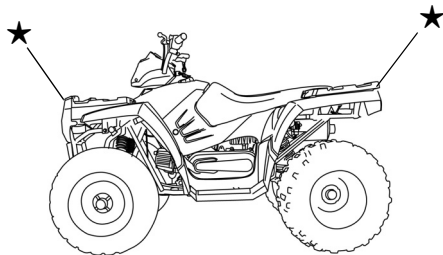

## Clutch Cover Warning

### WARNING

### NO STEP

Moving parts hazard under belt-clutch guard. To prevent serious injury, do not operate vehicle with guard removed.

Do not touch clutch cover, cover may become hot.

Do not modify engine or clutch. Doing so can cause part failure, possible imbalance, and excessive engine RPM which can result in serious injury or death.

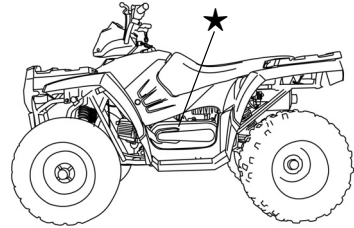



## **Driver Warnings**

**Be sure to read all of the following warnings about driving hazards and how to avoid them.**

**These warnings are provided for your child's safety. Be sure to explain to your young driver that the following hazards **MUST** be avoided at all times.**

# Driver Warnings

## **WARNING**

### **POTENTIAL HAZARD**

Operating this ATV without proper instruction.

### **WHAT CAN HAPPEN**

The risk of an accident is greatly increased if the operator does not know how to operate the ATV properly in different situations and on different types of terrain.

### **HOW TO AVOID THE HAZARD**

Beginning and inexperienced operators should complete the *ATV RiderCourse*<sup>sm</sup> offered by Polaris through the SVIA. They should then regularly practice the skills learned in the course and the operating techniques described in the Owner's Manual.

For more information about the *ATV RiderCourse*<sup>sm</sup> contact ATV Enrollment Express at (800) 887-2887 or visit [www.atvsafety.org](http://www.atvsafety.org).

### **WARNING**

#### **POTENTIAL HAZARD**

Failure to follow the age recommendations for this ATV.

#### **WHAT CAN HAPPEN**

Use by children of ATVs that are not recommended for their age can lead to severe injury or death of the child.

Even though a child may be within the age group for which some ATVs are recommended, he or she may not have the skills, abilities, or judgment needed to operate the ATV safely and may be involved in a serious accident.

#### **HOW TO AVOID THE HAZARD**

Follow the age recommendations for this ATV.



# Driver Warnings

## **⚠ WARNING**

### **POTENTIAL HAZARD**

Carrying a passenger on this ATV.

### **WHAT CAN HAPPEN**

Carrying a passenger greatly reduces your ability to balance and control this ATV.

Carrying a passenger could cause an accident, resulting in harm to you and/or your passenger.

### **HOW TO AVOID THE HAZARD**

Never carry a passenger. The purpose of the long seat is to allow the operator to shift position as needed during operation. It is not intended for passengers.

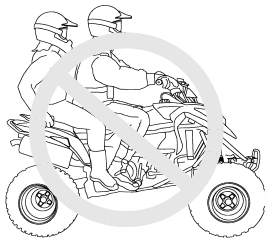

## Driver Warnings

### **WARNING**

#### **POTENTIAL HAZARD**

Operating this ATV on paved surfaces, including sidewalks, paths, parking lots and driveways.

#### **WHAT CAN HAPPEN**

The ATV tires are designed for off-road use. Paved surfaces may seriously affect handling and control of the ATV, and may cause the vehicle to go out of control.

#### **HOW TO AVOID THE HAZARD**

Avoid operating the ATV on pavement whenever possible. If you must ride on a paved surface, go slowly and do not make sudden turns or stops.

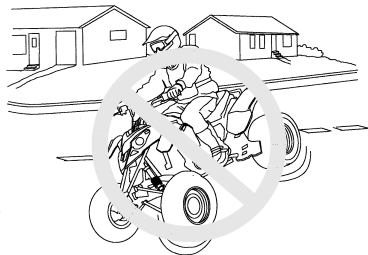

## Driver Warnings

### **⚠ WARNING**

#### **POTENTIAL HAZARD**

Operating this ATV on public streets, roads or highways.

#### **WHAT CAN HAPPEN**

You can collide with another vehicle.

#### **HOW TO AVOID THE HAZARD**

Never operate this ATV on any paved or unpaved public street, road or highway.

In many states it is illegal to operate ATVs on public streets, roads and highways.

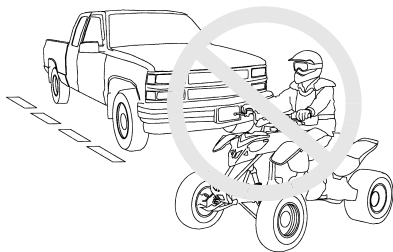

## Driver Warnings

### **WARNING**

#### **POTENTIAL HAZARD**

Operating this ATV without wearing protective gear.

#### **WHAT CAN HAPPEN**

Operating without an approved helmet increases the risk of a severe head injury or death in the event of an accident. Operating without eye protection and protective clothing can also result in injury.

#### **HOW TO AVOID THE HAZARD**

Always wear an approved helmet that fits properly. Always wear eye protection (goggles or face shield), gloves, boots, long-sleeved shirt or jacket, and long pants.

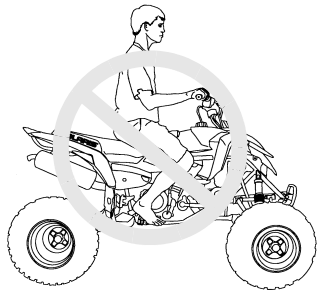

## Driver Warnings

### **⚠ WARNING**

#### **POTENTIAL HAZARD**

Operating this ATV after consuming alcohol or drugs.

#### **WHAT CAN HAPPEN**

Your judgment could be seriously affected.

You may react more slowly.

Your balance and perception will be affected.

You could have an accident.

#### **HOW TO AVOID THE HAZARD**

Never consume alcohol or drugs before or while driving this ATV.



## Driver Warnings

### **WARNING**

#### **POTENTIAL HAZARD**

Operating this ATV at excessive speeds.

#### **WHAT CAN HAPPEN**

Increases your chances of losing control of the ATV, which can result in an accident.

#### **HOW TO AVOID THE HAZARD**

Always travel at a speed which is proper for the terrain, visibility and operating conditions; and your experience.

### **WARNING**

#### **POTENTIAL HAZARD**

Failure to inspect the ATV before operating.  
Failure to properly maintain the ATV.

#### **WHAT CAN HAPPEN**

Increases the possibility of an accident or equipment damage.

#### **HOW TO AVOID THE HAZARD**

Always inspect your ATV each time you use it to make sure the ATV is in safe operating condition. Always follow the inspection and maintenance procedures and schedules described in the Owner's Manual.

# Driver Warnings

## **⚠ WARNING**

### **POTENTIAL HAZARD**

Attempting jumps and other stunts.

### **WHAT CAN HAPPEN**

Attempting stunts increases the chance of an accident, including an overturn.

### **HOW TO AVOID THE HAZARD**

Never attempt jumps, or other stunts. Avoid exhibition driving (don't show off).

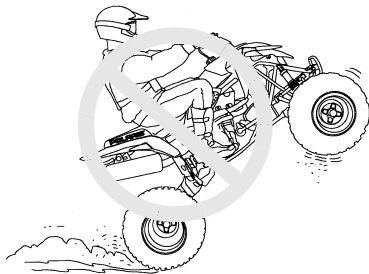

### **WARNING**

#### **POTENTIAL HAZARD**

Removing hands from handlebars or feet from footrests during operation.

#### **WHAT CAN HAPPEN**

Removing even one hand or foot can make it harder to control the ATV or could cause you to lose your balance and fall off the ATV. If you remove a foot from the footrest, your foot or leg may touch the rear wheels, which could injure you or cause an accident.

#### **HOW TO AVOID THE HAZARD**

Always keep both hands on the handlebars and both feet on the footrests of your ATV during operation.



# Driver Warnings

## **⚠ WARNING**

### **POTENTIAL HAZARD**

Failure to use extra care when operating this ATV on unfamiliar terrain.

### **WHAT CAN HAPPEN**

You can come upon hidden rocks, bumps, or holes, without enough time to react. This could cause the ATV to overturn or go out of control.

### **HOW TO AVOID THE HAZARD**

Go slowly and be extra careful when operating on unfamiliar terrain.

Always be alert to changing terrain conditions when operating the ATV.

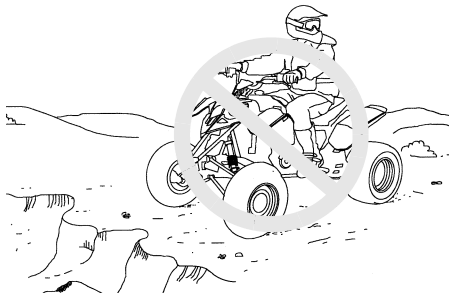

### **WARNING**

#### **POTENTIAL HAZARD**

Failure to use extra caution when operating on excessively rough, slippery or loose terrain.

#### **WHAT CAN HAPPEN**

Operating on excessively rough, slippery or loose terrain could cause loss of traction or loss of control, which could result in an accident or overturn.

#### **HOW TO AVOID THE HAZARD**

Do not operate on excessively rough, slippery or loose terrain until you've learned and practiced the skills necessary to control the ATV on such terrain.

Always use extra caution on rough, slippery or loose terrain.



## Driver Warnings

### **⚠ WARNING**

#### **POTENTIAL HAZARD**

Turning improperly.

#### **WHAT CAN HAPPEN**

Improper turns could cause loss of control and lead to a collision or overturn.

#### **HOW TO AVOID THE HAZARD**

Always follow proper procedures for turning as described in the owner's manual.

Practice turning at slow speeds before attempting to turn at faster speeds.

Never turn at excessive speed.

### **⚠ WARNING**

#### **POTENTIAL HAZARD**

Towing or pulling an object behind the ATV.

#### **WHAT CAN HAPPEN**

A wagon, sled or other object towed behind an ATV does not have brakes or steering. The object may overturn or collide with other objects and cause serious injuries.

#### **HOW TO AVOID THE HAZARD**

Never tow or pull an object behind the ATV.

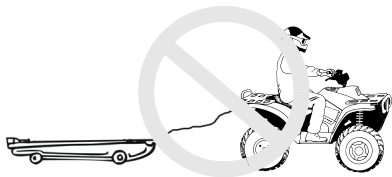

### **WARNING**

#### **POTENTIAL HAZARD**

Climbing hills improperly.

#### **WHAT CAN HAPPEN**

Improper hill climbing could cause loss of control or overturn.

#### **HOW TO AVOID THE HAZARD**

Always follow proper procedures for climbing hills as described in the Owner's Manual beginning on page 98.

Always check the terrain carefully before you start up any hill. Never climb hills with excessively slippery or loose surfaces. Shift your weight forward.

Never open the throttle suddenly. The ATV could flip over backwards. Never go over the top of any hill at high speed. An obstacle, a sharp drop, or another vehicle or person could be on the other side of the hill.

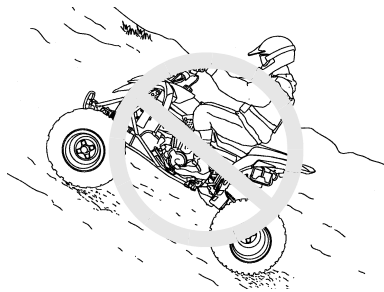

# Driver Warnings

## **⚠ WARNING**

### **POTENTIAL HAZARD**

Going down a hill improperly.

### **WHAT CAN HAPPEN**

Driving downhill improperly could cause loss of control or ATV overturn.

### **HOW TO AVOID THE HAZARD**

Always follow proper procedures for going down hills as described in the Owner's Manual. See page 104.

NOTE: A special technique is required when braking as you go downhill.

Always check the terrain carefully before you start down any hill. Shift your weight backward. Never go down a hill at high speed.

Avoid going down a hill at an angle, which would cause the vehicle to lean sharply to one side. Go straight down the hill when possible.

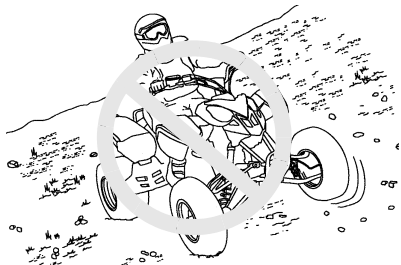

## Driver Warnings

### **WARNING**

#### **POTENTIAL HAZARD**

Improperly crossing hills and turning on hills.

#### **WHAT CAN HAPPEN**

Improperly crossing or turning as hills could cause loss of control or overturn.

#### **HOW TO AVOID THE HAZARD**

Never try to turn the ATV around on any hill until you've mastered the turning technique (on level ground) as described in the owner's manual. See page 102. Use extra caution when turning on any hill. Avoid crossing the side of a steep hill.

When crossing the side of a hill:

Always follow proper procedures as described in the owner's manual. Avoid hills with excessively slippery or loose surfaces. Shift your weight to the uphill side of the ATV.



## Driver Warnings

### **⚠ WARNING**

#### **POTENTIAL HAZARD**

Stalling, rolling backwards or improperly dismounting while climbing a hill.

**WHAT CAN HAPPEN:** The ATV could overturn and cause injury.

**HOW TO AVOID THE HAZARD:** Maintain steady speed when climbing a hill.

*If you lose all forward speed:* Keep your weight uphill. Apply the front brakes gradually (right lever). When fully stopped, apply the rear brake as well (left lever) and then lock the parking brake.

*If you begin rolling backwards:* Keep weight uphill. Never apply engine power. Never apply the rear brake while rolling backwards. Apply the front brake slowly. When fully stopped, apply rear brake as well, and then lock the parking brake. Dismount on uphill side, or to either side if pointed straight uphill. Turn the ATV around and remount, following the procedure described in the Owner's Manual. See page 102.

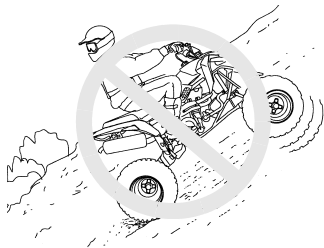

## Driver Warnings

### **WARNING**

#### **POTENTIAL HAZARD**

Skidding or sliding.

#### **WHAT CAN HAPPEN**

Skidding or sliding can cause loss of control.

If the tires regain traction unexpectedly, the ATV could overturn.

#### **HOW TO AVOID THE HAZARD**

On slippery surfaces such as ice, travel slowly and use extra caution to reduce the chance of skidding or sliding out of control.

### **WARNING**

#### **POTENTIAL HAZARD**

Improperly operating over obstacles.

#### **WHAT CAN HAPPEN**

Operating over obstacles could cause loss of control or overturn.

#### **HOW TO AVOID THE HAZARD**

Before operating in a new area, check for obstacles.

Avoid operating over large obstacles such as rocks and fallen trees when possible. If unavoidable, use extreme caution and always follow proper procedures as outlined in the owner's manual.



## Driver Warnings

### **WARNING**

#### **POTENTIAL HAZARD**

Riding on frozen lakes and rivers.

#### **WHAT CAN HAPPEN**

Severe injury or death can result if the ATV and/or the operator break through the ice.

#### **HOW TO AVOID THE HAZARD**

Never ride your ATV on a frozen body of water.

### **WARNING**

#### **POTENTIAL HAZARD**

Operating this ATV with improper tires, or with improper or uneven tire pressure.

#### **WHAT CAN HAPPEN**

Use of improper tires, or operation of the ATV with improper or uneven tire pressure, could cause loss of control or accident.

#### **HOW TO AVOID THE HAZARD**

Always use the size and type of tires specified in the owner's manual for the ATV.

Always maintain proper tire pressure as stated in the specifications section of the owner's manual.

### **WARNING**

#### **POTENTIAL HAZARD**

Operating the ATV through deep or fast-flowing water.

#### **WHAT CAN HAPPEN**

Tires may float, causing loss of traction and loss of control, which could lead to an accident or overturn.

#### **HOW TO AVOID THE HAZARD**

Avoid operating the ATV through deep or fast-flowing water. If it's unavoidable to enter water that exceeds the recommended maximum depth (see page 106), travel slowly, balance your weight carefully, avoid sudden movements, and maintain a slow and steady forward motion. Do not make sudden turns or stops, and do not make sudden throttle changes.

Wet brakes may have reduced stopping ability. Always test the brakes after leaving water. If necessary, apply them several times to let friction dry out the pads.

## Driver Warnings

### **WARNING**

#### **POTENTIAL HAZARD**

Overloading the ATV.

#### **WHAT CAN HAPPEN**

Overloading the ATV could cause changes in handling, which could lead to an accident.

#### **HOW TO AVOID THE HAZARD**

Never exceed the stated load capacity for this ATV.

If equipped with racks, cargo should be properly distributed and securely attached.

### **WARNING**

#### **POTENTIAL HAZARD**

Operating the ATV with improper modifications.

#### **WHAT CAN HAPPEN**

Improper installation of accessories or modification of the ATV may cause changes in handling which could lead to an accident.

#### **HOW TO AVOID THE HAZARD**

Never modify the ATV through improper installation or use of accessories. All parts and accessories added to the vehicle must be genuine Polaris Industries Inc. or equivalent components designed for use on this ATV and should be installed and used according to approved instructions.

## Driver Warnings

### **WARNING**

Safe operation of this rider-active vehicle requires good judgement and physical skills. Persons with cognitive or physical disabilities who operate this vehicle have an increased risk of overturns and loss of control which could result in severe injury or death. Do not allow disabled persons to operate this vehicle.

### **WARNING**

Damaged components can cause loss of control resulting in serious injury or death. After a rollover or an accident, have a qualified service dealer check the complete vehicle including, but not limited to, brakes, throttle and steering for possible damage.

### **WARNING**

Hot components can cause serious burns. Do not touch hot exhaust system components.

Hot components could cause a fire if exposed to combustible materials such as dry grass and weeds. Always inspect the underside of the ATV after driving through tall grass, weeds, brush and other tall ground cover. Promptly remove any grass or debris clinging to the vehicle.

### **WARNING**

Leaving the keys in the ignition can lead to unauthorized use of the vehicle resulting in serious injury or death. Always remove the ignition key when the vehicle is not in use.

## Vehicle Identification Numbers

Record your ATV's identification numbers and key number in the spaces provided. Remove the spare key and store it in a safe place. An ignition key can be duplicated only by ordering a Polaris key blank (using your key number) and mating it with one of your existing keys. The ignition switch must be replaced if all keys are lost.

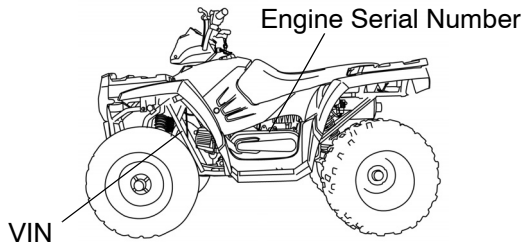

Vehicle Model Number: \_\_\_\_\_

Frame VIN: \_\_\_\_\_

Engine Serial Number: \_\_\_\_\_

Key Number (on the key): \_\_\_\_\_

# Features and Controls

## Main Key Switch

Turn the key clockwise to the ON position before starting the engine. To avoid draining the battery, always turn the key to the OFF position when the engine is not running.

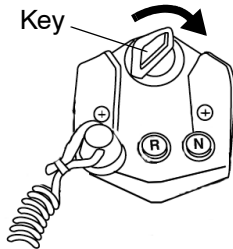

**OUTLAW**

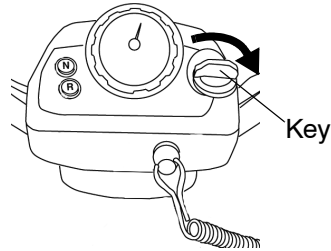

**SPORTSMAN**

### **⚠ WARNING**

Leaving the keys in the ignition can lead to unauthorized use of the vehicle resulting in serious injury or death. Always remove the ignition key when the vehicle is not in use.

## Features and Controls

### Engine Stop Switch

The engine will not start or run when the stop switch is down, in the OFF position. Its purpose is to provide the operator with a quick means of engine shutdown in case of stuck throttle or other emergency.

**NOTE:** Both the main switch and the engine stop switch shut off all electrical power to the entire vehicle. To stop the engine quickly, push the stop switch down.

### Choke Lever

Use the choke to start a cold engine. Push the choke lever to the left before starting the engine. When the engine starts, gradually return the choke lever to the OFF position as the engine warms up and runs smoothly.

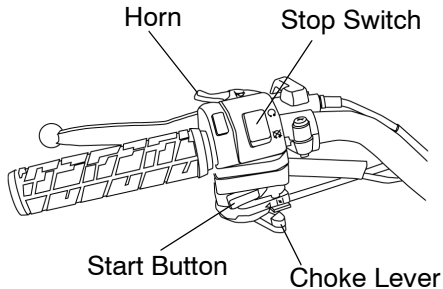

# Features and Controls

## Horn Button

Use the horn for emergencies and to let others know you're near.

## Engine Start Button

The start button is located slightly above the choke lever

1. Attach the tether strap securely to the vehicle and to the rider's right wrist.
2. Shift the transmission to neutral. The neutral light will come on when the lever is in neutral. See page 77.
3. Turn the key to the ON position.
4. Lock the parking brake.
5. Push the engine stop switch up to the ON position.
6. Press the start button.



# Features and Controls

## Throttle Controls

### **WARNING**

Operating an ATV with sticking or improperly operating throttle controls could cause an accident and lead to severe injury or death.

Never start or operate an ATV with a sticking or improperly operating throttle. Always contact your dealer for service if throttle problems arise.

Failure to check or maintain proper operation of the throttle system can result in an accident if the throttle lever sticks during operation. Always check the lever for free movement and return before starting the engine. Also check occasionally during operation.

## Features and Controls

### Throttle Lever

Press the throttle lever toward the handlebar to increase engine speed and vehicle movement. Engine speed returns to idle when the lever is released.

This ATV is equipped with an Electronic Throttle Control (ETC), which is designed to reduce the risk of a frozen or stuck throttle. If the throttle cable should stick in an open position when the operator releases the throttle lever, the engine will stop and power to the rear wheels will cease.

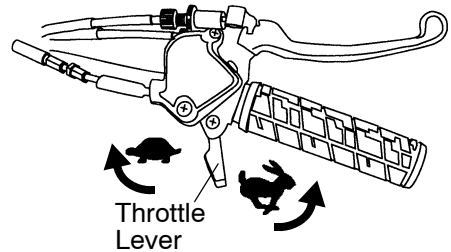

### **⚠ WARNING**

The Electronic Throttle Control (ETC) stops the engine in the event of a throttle system malfunction and is provided for your safety. Do not attempt to modify the ETC system or replace it with any after market throttle mechanism.

# Features and Controls

## Shift Lever

To change gears, stop the ATV. With the engine idling, move the lever to the desired gear. Do not try to shift gears with engine speed above idle or while the ATV is moving.

Maintaining shift linkage adjustment is important to assure proper transmission function. See your dealer if you experience any shifting problems.

### Shift Pattern

F: Forward Gear

N: Neutral

R: Reverse

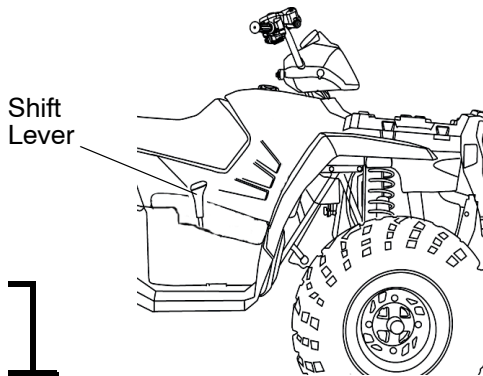

## Features and Controls

### **CAUTION**

Do not attempt to shift the transmission while the vehicle is moving or damage to the transmission could result. Always shift when the vehicle is stationary and the engine is at idle.

Always place the transmission in gear with the parking brake applied and turn the vehicle off whenever the vehicle is left unattended.

# Features and Controls

## Brakes

Squeeze both brake levers toward the handlebar at the same time to apply the brakes. The left lever controls the rear brakes. The right lever controls the front brakes.

Rear Brakes

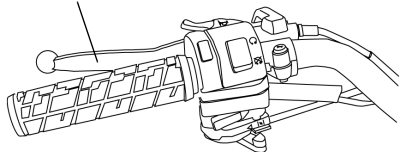

Front Brakes

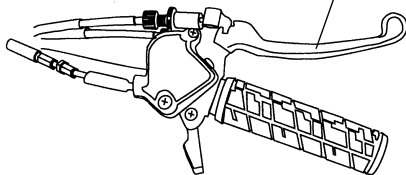

### **⚠ WARNING**

Applying only one brake could cause loss of control and result in serious injury or death. Always apply both brakes at the same time.

# Features and Controls

## Brakes

### Parking Brake

1. Squeeze the left brake lever.
2. Push the parking brake lock down to lock the brake lever in place.
3. To release the parking brake lock, squeeze and release the brake lever. The parking brake will release automatically.

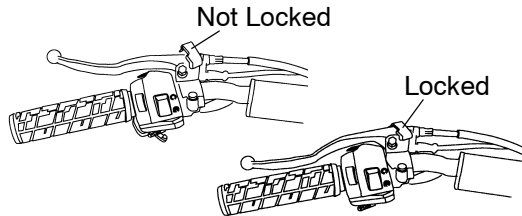

### **⚠ WARNING**

Operating the ATV while the parking brake is engaged could cause an accident resulting in serious injury or death. It could also result in driveline or engine damage. Always be sure to disengage the parking brake before operating the ATV.

# Features and Controls

## Brakes

### Parking Brake

1. Always shift the transmission to neutral and lock the parking brake before starting the engine.
2. After the engine has warmed enough for operation, shift to the desired gear.
3. Release the parking brake and gently apply the throttle.
4. Always lock the parking brake whenever the vehicle is left unattended.

# Features and Controls

## Lights

### **⚠ WARNING**

Polaris Youth ATVs are not equipped with lights that are designed for driving in the dark. Do not operate this ATV after dark. Use caution and drive at reduced speeds in conditions of reduced visibility. This ATV is designed for off-road use only. Do not operate this ATV on streets or highways.

### **Indicator Lights**

Indicator lights on the ATV let you know when your ATV is in neutral or reverse.

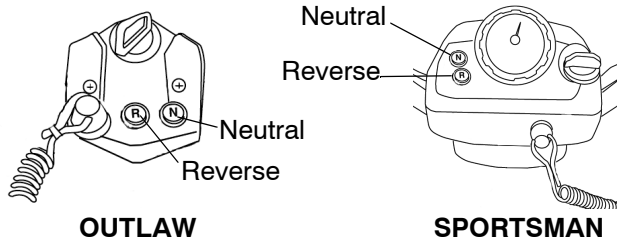



# Features and Controls

## Fuel System

### **WARNING**

Gasoline is highly flammable and explosive under certain conditions.

- Always exercise extreme caution whenever handling gasoline.
- Always refuel with the engine stopped, and outdoors or in a well ventilated area.
- Do not smoke or allow open flames or sparks in or near the area where refueling is performed or where gasoline is stored.
- Do not overfill the tank. Do not fill the tank neck.
- If gasoline spills on your skin or clothing, immediately wash it off with soap and water and change clothing.
- Never start the engine or let it run in an enclosed area. Engine exhaust fumes are poisonous and can cause loss of consciousness or death in a short time.
- Turn the fuel valve off whenever the ATV is stored or parked. See page 81.

## Fuel System

### **WARNING**

The engine exhaust from this product contains chemicals known to cause cancer, birth defects or other reproductive harm.

Operate this vehicle only outdoors or in well-ventilated areas.

# Features and Controls

## Fuel System

### Gas Cap

The fuel tank filler cap is located directly below the handlebars. Use unleaded gasoline with a minimum pump octane of 87. Refer to the specifications section beginning on page 178 for fuel tank capacity.

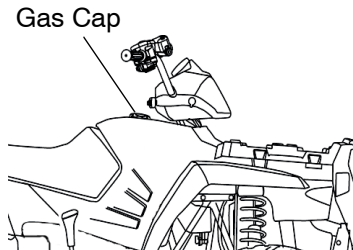

# Features and Controls

## Fuel Valve

The fuel valve is located on the left side of the ATV. It has three settings.

**OFF:** For vehicle storage and when transporting.

**ON:** For normal operation.

**RES:** For reserve supply if main supply is exhausted.

**NOTE:** The reserve setting allows operation for approximately 7-10 miles (11-16 km). Always refill the gas tank as soon as possible after using the main supply. Always return the valve to the ON position after refueling.

Sportsman 90  
Fuel Valve

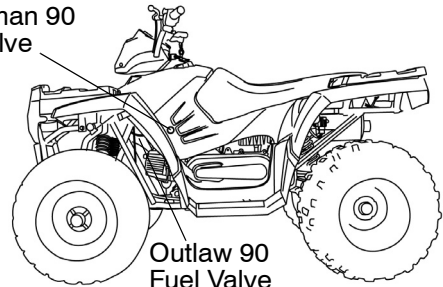

Outlaw 90  
Fuel Valve



OFF

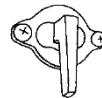

ON

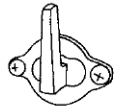

RES

## Features and Controls

### Kick-Start Lever

If the battery becomes too weak to start the engine, use the kick-start lever to start the engine until the battery is serviced.

1. Position the vehicle on a level surface.
2. Shift the transmission to neutral.
3. Lock the parking brake.
4. Fold out the kick-start lever on the left side of the ATV.

**NOTE:** A 10/12mm wrench is provided in the tool kit for removing or installing the lever. If not installed, make sure the rubber cap is on the kick-start shaft to protect the rider. Store the lever under the seat when it's not installed.

5. Push the engine stop switch up to the ON position.
6. Turn the key to ON.
7. Place your foot on the kick-start, then thrust your heel downward to crank the engine.
8. After the engine has started, fold the kick-start lever back into place.

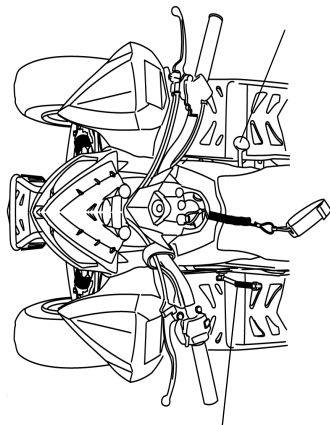

Kick-Start Lever

## Break-in Period

The break-in period for your new Polaris 4-cycle ATV is defined as the first ten hours of operation, or the time it takes to use the first two full tanks of gasoline. No single action on your part is as important as following the procedures for a proper break-in. Careful treatment of a new engine will result in more efficient performance and longer life for the engine. Perform the following procedures carefully.

### CAUTION

Excessive heat build-up during the first three hours of operation will damage close-fitted engine parts. Do not operate at full throttle or high speeds for extended periods during the first three hours of use.

Mixing brands or using a non-recommended oil may cause serious engine damage. Always use the recommended oil. Never substitute or mix oil brands.

## Break-in Period

1. Fill the fuel tank with gasoline. See page 78.
2. Check the oil level. Add the recommended oil as needed to maintain the oil level in the proper range. See page 125.
3. Drive slowly at first. Select an open area that allows room to familiarize yourself with vehicle operation and handling.
4. Vary throttle positions. Do not operate at sustained idle.
5. Perform regular checks on fluid levels, controls and areas outlined on the daily pre-ride inspection checklist. See page 85.
6. Perform the following maintenance at the end of the break-in period.

Item	Remarks	See Page
Engine oil change	Perform break-in oil change	126
Oil pre-filter screen	Clean filter with oil change	127
Transmission oil	Perform break-in oil change	130
Valve clearance	See your dealer for inspection and adjustment	--

## Pre-Ride Inspection

### **WARNING**

If a proper inspection is not done before each use, severe injury or death could result. Always inspect the ATV before each use to ensure it's in proper operating condition.

### **Pre-Ride Checklist**

<b>Item</b>	<b>Remarks</b>	<b>Page</b>
Brake system / lever travel	Ensure proper operation	145, 149
Front suspension	Inspect, lubricate if necessary	122
Rear suspension	Inspect, lubricate if necessary	122
Steering	Ensure free operation, lubricate if necessary	150, 152



## Pre-Ride Inspection

<b>Pre-Ride Checklist</b>		
<b>Item</b>	<b>Remarks</b>	<b>Page</b>
Tires	Check condition and pressure	159
Wheels / fasteners	Inspect, ensure fastener tightness; check that axle nuts are secured by cotter pins	161, 162
Fuel and oil	Check and fill as needed	78, 80
Throttle	Check for proper operation	25, 70, 71
Engine stop switch	Check for proper function	68
Daytime running lights (if equipped)	Check for proper operation	165
Brakelight	Check for proper operation	163

## Pre-Ride Inspection

<b>Pre-Ride Checklist</b>		
<b>Item</b>	<b>Remarks</b>	<b>Page</b>
Air filter, pre-filter	Inspect, clean or replace	156
Drive chain	Check condition and slack; refer to drive chain adjustment	153
Frame nuts, bolts, fasteners	Inspect, ensure tightness	--
Loose or damaged components	Visually inspect for any damaged components or loose fasteners	--
Riding gear	Wear helmet, goggles, protective clothing	92

## Starting the Engine

### **WARNING**

Engine exhaust contains poisonous carbon monoxide and can cause loss of consciousness resulting in severe injury or death. Never run an engine in an enclosed area.

### **CAUTION**

Operating the ATV immediately after starting could cause engine damage. Allow the engine to warm up for several minutes before operating.

## Starting the Engine

1. Shift the transmission to neutral.
2. Lock the parking brake.
3. Turn the fuel valve on.
4. Sit on the vehicle and attach the tether strap to the ATV and to your right wrist.

**NOTE:** The choke is fully on when the lever is pushed completely to the left. The choke is off when the lever is pushed completely to the right. The choke can be adjusted gradually, depending on how much choke is needed for starting.

5. If the engine is cold, use full choke by pushing the choke lever all the way to the left. A warm engine will not require the use of the choke.
6. Push the engine stop switch up to the ON position.
7. Turn the ignition key to ON.

**NOTE:** Do not press the throttle while starting the engine.

## Starting the Engine

8. Squeeze the rear brake lever and press the starter button.

**NOTE:** The rear brake lever must be engaged or the engine won't start.

9. Activate the starter for a maximum of five seconds, releasing the button when the engine starts. If it doesn't start, release the starter, wait five seconds, then activate for another five seconds. Repeat until the engine starts.

10. If the engine slows or stops, position the choke lever half way to allow proper engine warm up. Vary the RPM slightly with the throttle to aid in warm up.

11. When the engine idles smoothly, push the choke lever all the way to the right.

## Stopping the Engine

1. Release the throttle completely and brake to a complete stop.
2. Shift the transmission to neutral.
3. Stop the engine.

**NOTE:** There are three ways to stop the engine.

- Turn the key off.
- Push the engine stop switch down.
- Pull the tether strap off the ATV.

**NOTE:** To avoid draining the battery, always turn the key to the OFF position when the engine is not running.

4. Lock the parking brake.

### **WARNING**

A rolling vehicle can cause property damage and serious injury. Always apply the parking brake after stopping the engine.

## Driving Safely

### Riding Gear

Always wear clothing suited to the type of riding. ATV riding requires special protective clothing for comfort and to reduce the chance of injury.

#### Helmet

Wearing a helmet can prevent a severe head injury. Whenever riding a Polaris vehicle, always wear a helmet that meets or exceeds established safety standards.

Approved helmets in the USA and Canada bear a U.S. Department of Transportation (DOT) label.

Approved helmets in Europe, Asia and Oceania bear the ECE 22.05 label. The ECE mark consists of a circle surrounding the letter E, followed by the distinguishing number of the country which has granted approval. The approval number and serial number will also be displayed on the label.

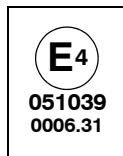
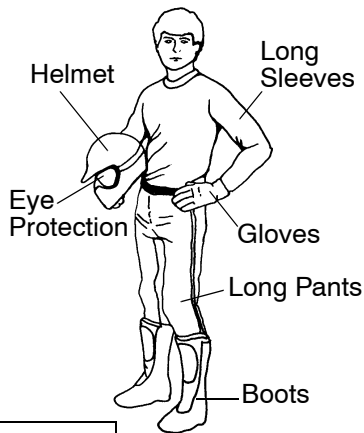

### **Riding Gear**

#### **Eye Protection**

Do not depend on eyeglasses or sunglasses for eye protection. Whenever riding a Polaris vehicle, always wear shatterproof goggles or use a shatterproof helmet face shield. Polaris recommends wearing approved Personal Protective Equipment (PPE) bearing markings such as VESC 8, V-8, Z87.1, or CE. Make sure protective eye wear is kept clean.

#### **Gloves**

Off-road style gloves with knuckle pads are the best for comfort and protection.

#### **Boots**

The best footwear is a pair of strong over-the-calf boots with low heels.

#### **Clothing**

Always wear long sleeves and long pants to protect arms and legs. Riding pants with knee-pads and a jersey with shoulder pads provide the best protection.



# Driving Safely

## Driving Procedure

1. Sit upright with both feet on the footrests and both hands on the handlebars.
2. Shift the transmission to neutral.
3. Start the engine and allow it to warm up.
4. Check your surroundings and determine your path of travel.
5. Squeeze the left brake lever.
6. Shift the transmission to the desired gear.
7. Slowly release the brake lever.
8. Slowly press the throttle with your right thumb and begin driving.
9. Drive slowly at first. Practice turning and using the throttle and brakes on level surfaces.



### Making Turns

Your ATV is equipped with a solid rear axle, which drives both rear wheels equally at all times. This means that the wheel on the outside of the turn must travel a greater distance than the inside wheel when turning and the inside tire must slip traction slightly. To turn, steer in the direction of the turn, leaning your upper body to the inside of the turn while supporting your weight on the outer footrest. This technique alters the balance of traction between the rear wheels, allowing the turn to be made smoothly.

**NOTE:** Practice making turns at slow speeds.

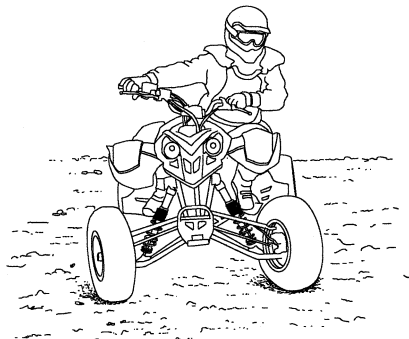

### **⚠ WARNING**

Turning at sharp angles or at excessive speeds can result in vehicle overturn and lead to serious injury. Avoid turning at sharp angles. Never turn at high speeds.

## Driving Safely

### Driving on Slippery Surfaces

#### **WARNING**

Failure to exercise care when operating on slippery surfaces can result in loss of tire traction and cause loss of control, accident, and serious injury or death.

Never apply the brakes during a skid.

Do not operate on excessively slippery surfaces.

Always reduce speed and use additional caution.

### Driving on Slippery Surfaces

Whenever riding on slippery surfaces such as wet trails or loose gravel, or during freezing weather, follow these precautions:

1. Slow down when entering slippery areas.
2. Maintain a high level of alertness, reading the trail and avoiding quick, sharp turns, which can cause skids.
3. Correct a skid by turning the handlebars in the direction of the skid and shifting your body weight forward.



## Driving Safely

### Driving Uphill

#### **WARNING**

Braking and handling are greatly affected when operating in hilly terrain. Improper procedure could cause loss of control or overturn and result in serious injury or death.

Avoid climbing steep hills (15° maximum).

Use extreme caution when operating on hills, and follow proper operating procedures outlined in the owner's manual.

### Driving Uphill

Whenever traveling uphill, follow these precautions:

1. Always travel straight uphill.
2. Avoid steep hills ( $15^{\circ}$  maximum).
3. Keep both feet on the footrests.
4. Transfer your weight forward.
5. Proceed at a steady rate of speed and throttle opening.
6. Remain alert and be prepared to take emergency action. This may include quick dismounting of the vehicle.

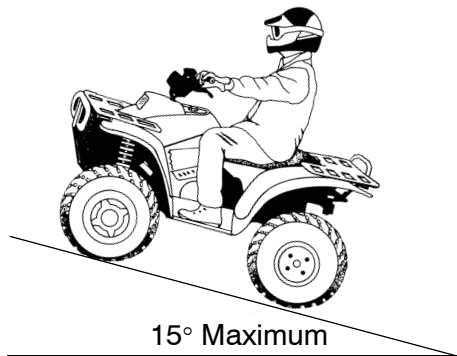

## Driving Safely

### Driving Across Hillsides

#### **WARNING**

Improperly crossing hills or turning on hills can result in loss of control or vehicle overturn, resulting in severe injury or death. Avoid crossing the side of a hill when possible. Follow proper procedures as outlined in the owner's manual.

## Driving Across Hillside

Sidehilling can be a dangerous type of driving and should be avoided if at all possible. If you do enter into a situation where sidehilling is necessary, follow these precautions:

1. Slow down.
2. Lean into the hill, transferring your upper body weight uphill while keeping your feet on the footrests.
3. Steer slightly into the hill to maintain direction.

**NOTE:** If the vehicle begins to tip, quickly turn the front wheel downhill, if possible, or dismount on the uphill side *immediately!*

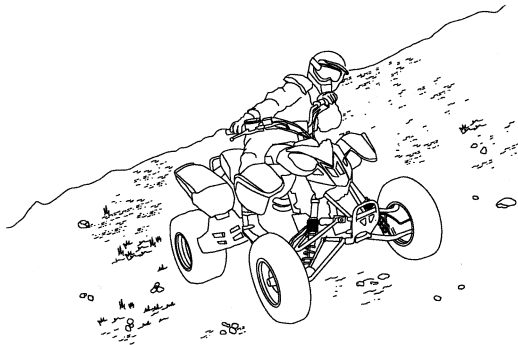



## Driving Safely

### Turning Around on a Hill

#### **WARNING**

Improper hill climbing procedures could cause loss of control or overturn and result in serious injury or death.

Avoid climbing steep hills (15° maximum).

Use extreme caution when operating on hills, and follow proper operating procedures outlined in the owner's manual.

If the vehicle stalls while climbing a hill, never back it down the hill! One maneuver that can be used when it's necessary to turn around while climbing a hill is the K-turn:

1. Stop and lock the parking brake while maintaining body weight uphill.
2. Shift the transmission to neutral.
3. Shut off the engine.
4. Dismount on the uphill side of the vehicle, or on the left if the vehicle is pointing straight uphill.

### Turning Around on a Hill

5. Staying uphill of the ATV, turn the handlebars full left.
6. While holding the brake, release the parking brake lock and slowly release the brake, allowing the ATV to roll around to your right until it's pointing across the hill or slightly downward.
7. Lock the parking brake and remount the ATV from the uphill side, maintaining body weight uphill.
8. Restart the engine.
9. Squeeze the rear brake lever.
10. Shift the transmission to forward gear.
11. Release the parking brake and drive slowly, controlling speed with the rear brake, until the ATV is on more level ground.

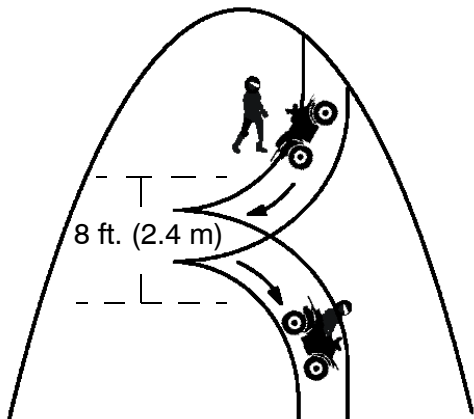

## Driving Safely

### Driving Downhill

Whenever descending a hill, follow these precautions:

1. Drive directly downhill.
2. Transfer your weight to the rear of the vehicle.
3. Slow down.
4. Apply the front and rear brakes at the same time, and very slightly, to aid in slowing.

#### **⚠ WARNING**

Excessive speed can cause loss of control and lead to serious injury or death. Always operate slowly when traveling downhill.

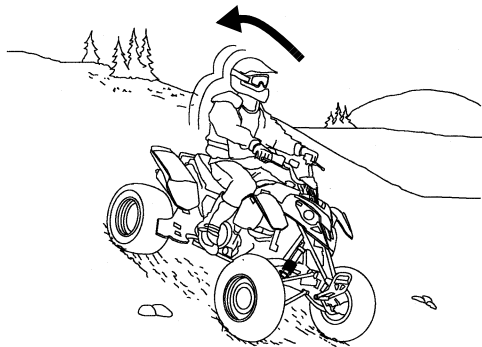

### Parking on a Hill or Incline

Avoid parking on a hill or incline if possible. If it's unavoidable, follow these precautions:

1. Turn the engine off.
2. Lock the parking brake.
3. Always block the rear wheels on the downhill side as shown in the illustration.
4. Turn the fuel valve off.

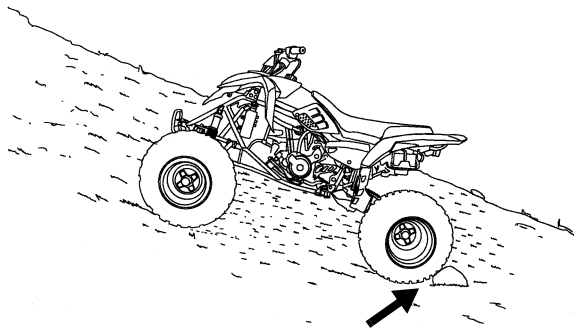

## Driving Safely

### Driving Through Water

Your ATV can safely operate through shallow water. The recommended maximum depth for your ATV is below the bottom of the footrests. Follow these procedures when operating through water:

1. Determine water depths before driving through water.
2. If crossing a stream, choose a crossing where both banks have gradual inclines.
3. Proceed slowly, avoiding rocks and obstacles if possible.
4. After driving through water, dry the brakes by applying light pressure to the levers (while moving) until braking action is normal. If you do not perform this procedure, your brakes may be ineffective.



Maximum Depth

### Driving Through Water

Avoid operating your ATV through deep or fast flowing water. If the ATV is operated in deeper water than recommended, it's critical to have it serviced as outlined in the maintenance chart beginning on page 114. The following areas need special attention: engine oil, gearcase oil, front and rear gearcases (if equipped) and all grease fittings.

#### **CAUTION**

Major engine damage can result from driving this ATV in deeper water than recommended. If your vehicle becomes immersed or is operated in water that exceeds the bottom of the footrests, take it to your dealer for service before starting the engine.

## Driving Safely

### Driving Over Obstacles

Be alert! Look ahead and learn to read the terrain you're traveling on. Be constantly alert for hazards such as logs, rocks and low hanging branches.

#### **⚠ WARNING**

Severe injury or death can result if your vehicle comes in contact with a hidden obstacle. Not all obstacles are immediately visible. Travel with caution in unfamiliar terrain.

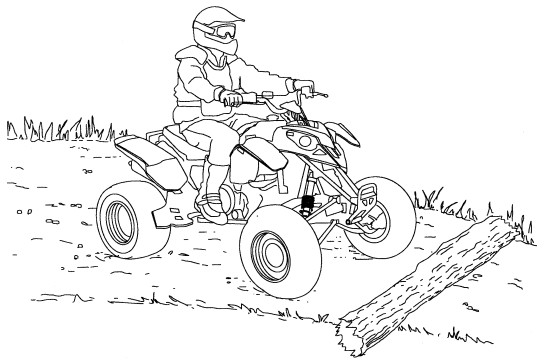

### Driving in Reverse

Follow these guidelines when operating in reverse:

1. Back slowly.
2. Apply the brakes lightly for stopping.
3. Avoid turning at sharp angles.
4. Always avoid backing downhill.
5. Never open the throttle suddenly while backing.
6. Always look left, right and behind the ATV before backing.

#### **WARNING**

Failure to use caution when operating in reverse can result in serious injury or death. Before shifting into reverse, always check for obstacles or people behind the vehicle and follow the reverse operation procedures outlined in this manual. Always back slowly.



## Driving Safely

### Hauling Cargo

The Sportsman 90 was designed with racks to carry small loads. Read and follow all of the instructions for hauling cargo on the following pages. Never carry cargo on the Outlaw 90.

#### **⚠ WARNING**

Hauling cargo improperly can may cause loss of control and result in serious injury or death. Always carry cargo as instructed in safety decals and in the owner's manual.

- Place  $\frac{1}{3}$  of the cargo weight on the front rack and  $\frac{2}{3}$  on the rear rack. Carrying loads on only one rack increases the chance of a tipover.
- Slow down. Allow more space for stopping the ATV when hauling cargo.

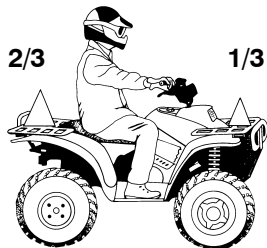

### Hauling Cargo

- Never exceed the weight capacities for the vehicle. Capacities are listed in the specifications section beginning on page 178.
- Secure all cargo before driving. Loose cargo may move or shift, which could cause loss of control or a tipover. Use suitable tie-downs or rope to secure the cargo. Do not allow cargo or tie straps to hang over the edges of the racks.
- Carry only small loads that fit on the racks. Tall loads raise the center of gravity of the vehicle and may cause loss of control or a tipover.
- Never allow a person to ride on the racks.
- Never tow or pull an object behind the ATV. A wagon, sled or other object towed behind an ATV does not have brakes or steering. The object may overturn or collide with other objects and cause serious injuries.

## **Emission Control Systems**

### **Noise Emission Control System**

Do not modify the engine, intake or exhaust components, as doing so may affect compliance with U.S.A. EPA noise control requirements (40 CFR 205) and local noise level requirements.

### **Operation on Public Lands in the U.S.A.**

Your Polaris vehicle has a spark arrestor that was tested and qualified to be in accordance with the USDA Forest Service Standard 5100-1C. Federal law requires that this spark arrestor be installed and functional when the vehicle is operated on public lands.

Operation of off-road vehicles on public lands in the U.S.A. is regulated by 43 CFR 8343. Violations are subject to monetary penalties. Federal regulations can be viewed online at [www.gpoaccess.gov/ecfr/](http://www.gpoaccess.gov/ecfr/).

### **Crankcase Emission Control System**

This engine is equipped with a closed crankcase system. Blow-by gases are forced back to the combustion chamber by the intake system. All exhaust gases exit through the exhaust system.

# Emission Control Systems

## Exhaust Emission Control System

The emissions from the exhaust of this vehicle are controlled by engine design, including factory-set fuel delivery and ignition. The engine and related components must be maintained at Polaris specifications to achieve optimal performance.

Engine idle speed is the only adjustment Polaris recommends that the operator perform. Any other adjustments should be performed by an authorized Polaris dealer.

The emissions label is located on the clutch cover or engine case near the clutch box.

**NOTE:** The installation of devices that effectively increase exhaust emissions beyond their legal limits will void all manufacturer warranties and may violate laws governing the registration and operation of this vehicle.

## Electromagnetic Interference

This spark ignition system complies with Canadian ICES-002.

This vehicle complies with European directives 97/24/EC and 89/336/EEC.

# **Maintenance**

## **Periodic Maintenance Chart**

To help you perform routine maintenance, a tool kit is provided in the storage compartment under the seat.

Maintenance intervals in the following charts are based upon average riding conditions and an average vehicle speed of approximately 10 miles per hour. Vehicles subjected to severe use must be inspected and serviced more frequently. Record maintenance and service in the Maintenance Log beginning on page 198.

## Periodic Maintenance Chart

Inspect, clean, lubricate, adjust and replace parts as necessary. When inspection reveals the need for replacement parts, use genuine Polaris parts available from your Polaris dealer.

**NOTE:** Service and adjustments are critical. If you're not familiar with safe service and adjustment procedures, have a qualified dealer perform these operations.

### Severe Use Definition

- Frequent immersion in mud, water or sand
- Racing or race-style high RPM use
- Prolonged low speed, heavy load operation
- Extended idle
- Short trip cold weather operation

# Maintenance

## Periodic Maintenance Chart

### **WARNING**

Improperly performing the procedures marked with a ■ could result in component failure and lead to serious injury or death. Have an authorized Polaris dealer perform these services.

### **Maintenance Chart Key**

► Perform these operations more often under severe use, such as in dirty or wet conditions, to purge water or dirt contamination from grease fittings and other critical components.

**E** Emission-related service (Failure to conduct this maintenance will not void the emissions warranty but may affect emissions.)

■ Dealer service item.

# Maintenance

## Periodic Maintenance Chart

Item		Maintenance Interval (whichever comes first)			Remarks	See Page
		Hours	Calendar	Miles (Km)		
■	Steering	--	Daily	--	Check each day before operating the vehicle. Make adjustments as needed. See the Pre-Ride Checklist.	85
▶	Front suspension	--	Daily	--		
▶	Rear suspension	--	Daily	--		
	Tires	--	Daily	--		
▶	Brake lever travel	--	Daily	--		
	Brake system	--	Daily	--		
	Wheels/fasteners	--	Daily	--		
	Frame fasteners	--	Daily	--		
▶	Engine oil level	--	Daily	--		
▶E	Air filter, pre-filter & main element	--	Daily	--	Inspect; clean often; replace as needed	156
▶	Air box sediment tube	--	Daily	--	Drain deposits when visible	--
	Headlamp/tail lamp	--	Daily	--	Check operation; apply dielectric grease if replacing	163 165



# Maintenance

## Periodic Maintenance Chart

Item		Maintenance Interval (whichever comes first)			Remarks	See Page
		Hours	Calendar	Miles (Km)		
	Drive chain	--	Daily	--	Inspect daily; adjust and lubricate if needed	153
	CVT housing (if equipped)	--	Weekly	--	Drain water as needed, check often if operating in wet conditions	137
	Break-in Maintenance	After first 10 hours of operation			Perform break-in maintenance	83
▶■	Brake lever travel/brake freeplay	10	Monthly	100 (160)	Inspect regularly	145 149
■E	Spark plug	10	Monthly	100 (160)	Clean; check condition; adjust gap; replace as needed	132
	Idle speed	10	Monthly	100 (160)	Check; adjust as needed	141
■E	Choke	10	Monthly	100 (160)	Check for proper operation; see your dealer for adjustments	

▶ Perform these procedures more often for vehicles subjected to severe use.

E Emission-Related Service

■ Have an authorized Polaris dealer perform these services.

# Maintenance

## Periodic Maintenance Chart

Item		Maintenance Interval (whichever comes first)			Remarks	See Page
		Hours	Calendar	Miles (Km)		
	Battery	20	Monthly	200 (320)	Check terminals; clean; test	166
▶	Engine oil change	30	6 M	300 (480)	Drain and change the oil	126
▶	Transmission oil	40	12 M	400 (640)	Drain and change the oil	130
▶	Oil pre-filter screen	40	12 M	400 (640)	Clean filter at every oil change; clean annually if ATV is operated less than 10 hours	127
▶	General lubrication	50	3 M	500 (800)	Lubricate all fittings, pivots, cables, etc.	--
■E	Valve clearance	50	3 M	500 (800)	Check clearance; see your dealer for adjustments	--
	Carburetor float bowl	50	6 M	500 (800)	Drain bowl periodically and prior to storage	--
■E	Throttle cable/ETC switch	50	6 M	500 (800)	Inspect; adjust; lubricate; replace if necessary	--
■E	Choke cable	50	6 M	500 (800)	Inspect; adjust; lubricate; replace if necessary	--

# Maintenance

## Periodic Maintenance Chart

Item		Maintenance Interval (whichever comes first)			Remarks	See Page
		Hours	Calendar	Miles (Km)		
<b>E</b>	Carburetor air intake ducts/flange	50	6 M	500 (800)	Check for proper sealing/air leaks	--
■	Drive belt	50	6 M	500 (800)	See your Polaris dealer	--
▶■	Brake pad wear	50	6 M	500 (800)	See your Polaris dealer	--
■E	Fuel system	100	12 M	1000 (1600)	Check for leaks at tank cap, lines, fuel valve, filter, pump, carburetor; replace lines every two years	--
■E	Fuel filter	100	12 M	1000 (1600)	Change filter	129
▶	Engine mounts	100	12 M	1000 (1600)	Inspect	--
	Exhaust muffler/pipe	100	12 M	1000 (1600)	Inspect	--
■	Ignition timing	100	12 M	1000 (1600)	Inspect	--

▶ Perform these procedures more often for vehicles subjected to severe use.

**E** Emission-Related Service

■ Have an authorized Polaris dealer perform these services.

# Maintenance

## Periodic Maintenance Chart

Item		Maintenance Interval (whichever comes first)			Remarks	See Page
		Hours	Calendar	Miles (Km)		
▶	Wiring	100	12 M	1000 (1600)	Inspect for wear, routing, security; apply dielectric grease to connectors subjected to water, mud, etc.	--
■	Clutches (drive and driven)	100	12 M	1000 (1600)	Inspect; clean; replace worn parts	--
■	Front wheel bearings	100	12 M	1000 (1600)	Inspect; replace as needed	--
	Spark arrestor	300	36 M	3000 (4800)	Clean out	138
■	Toe adjustment	--			Inspect periodically; adjust when parts are replaced	150

## Maintenance Lubrication Guide

Item	Lube	Method
Engine Oil	Polaris Synthetic Youth Oil or Synthetic SAE 40	See page 124.
Gearcase (Transmission) Oil Level	Premium AGL Synthetic Gearcase Lube	See page 130.
Drive Chain	Polaris Chain Lube or SAE 80/90	See page 153.
▶ Front Suspension (A-Arm)	Polaris All Season Premium Grease or grease conforming to NLGI No. 2	Inspect; tighten fasteners; grease (also after washing ATV or driving in water).

▶ Perform these procedures more often for vehicles subjected to severe use

## Lubrication Guide

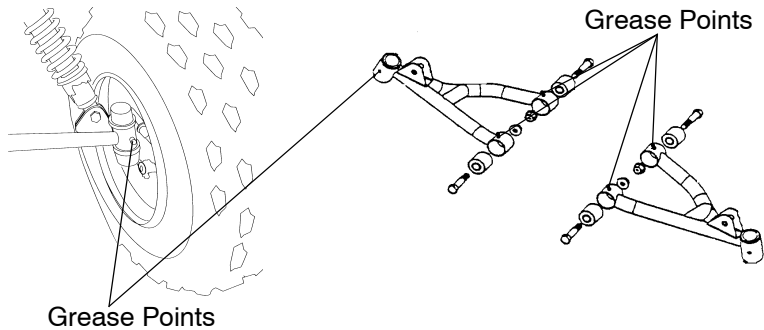

# Maintenance

## Engine Oil

### Oil Recommendations

Always check and change the engine oil at the intervals outlined in the Periodic Maintenance Chart beginning on page 114. Oil may need to be changed more frequently if Polaris oil is not used. Do not use automotive oil. See page 182 for the part numbers of Polaris products.

Under These Operating Conditions	Use This Recommended Oil
Outside air temperature is <i>above</i> 32° F/0° C	Polaris Synthetic Youth Oil (or Synthetic SAE40)
Outside air temperature is <i>below</i> 32° F/0° C	Semi-Synthetic 20W-40

## CAUTION

Mixing brands or using a non-recommended oil may cause serious engine damage. Always use the recommended oil. Never substitute or mix oil brands.

## Engine Oil Check

Maintain the oil level within the safe range on the dipstick. Do not overfill.

1. Position the vehicle on a level surface.
2. Remove the dipstick. Wipe it dry with a clean cloth.
3. Reinstall the dipstick completely.
4. Remove the dipstick and check the oil level.

**NOTE:** A rising oil level between checks in cool weather driving can indicate contaminants such as gas or moisture collecting in the crankcase. If the oil level is over the full/safe mark, change the oil immediately.

5. Add the recommended oil as needed.
6. Reinstall the dipstick.

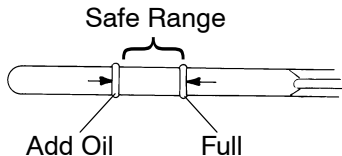
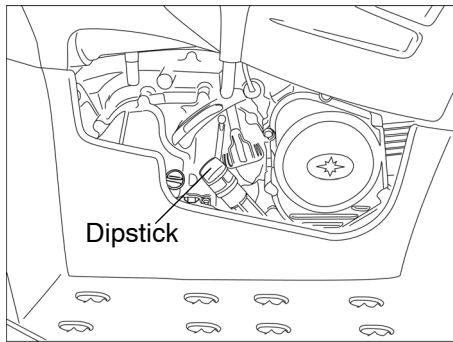



## Maintenance

### Engine Oil Change

1. Position the vehicle on a level surface.
2. Clean the area around the pre-filter plug.
3. Start the engine. Allow it to idle for two to three minutes.
4. Stop the engine.

<b>⚠ CAUTION</b>
------------------

Hot oil can cause serious burns to skin. Do not allow hot oil to come into contact with skin.
---

### Engine Oil Change

5. Place a drain pan under the engine crankcase.
6. Remove the pre-filter plug. Allow the oil to drain completely.
7. Wash the oil pre-filter screen with solvent to remove debris. Allow the screen to air dry.
8. Clean the pre-filter plug. Install a new sealing washer on the plug.

**NOTE:** The sealing surfaces on the plug and crankcase should be clean and free of burrs, nicks or scratches.

9. Reassemble the pre-filter screen and spring to the pre-filter plug.



## Maintenance

### Engine Oil Change

10. Reinstall the pre-filter drain plug. Torque to 11 ft. lbs. (15 Nm).
  11. Remove the dipstick. Add 29 oz. (850 ml) of the recommended oil. Do not overfill.
- NOTE:** See the specifications section beginning on page 178 for capacities.
12. Reinstall the dipstick.
  13. Start the engine. Allow it to idle for one to two minutes.
  14. Stop the engine and inspect for leaks.
  15. Check the oil level. Add oil as needed to bring the level to the upper mark on the dipstick.
  16. Dispose of used oil properly.

### Fuel Filter

The Polaris ATV is equipped with an in-line fuel filter. This filter should be replaced by your dealer at the intervals recommended in the Periodic Maintenance Chart beginning on page 114. Do not attempt to clean the fuel filter.

# Maintenance

## Transmission Oil Check

The gearcase fill plug is located on the side of the gearcase on the right side of the ATV. Maintain the oil level at the bottom of the fill plug hole threads.

Always check and change the oil at the intervals outlined in the Periodic Maintenance Chart beginning on page 114. Polaris recommends the use of AGL Synthetic Gearcase Lubricant. See page 182 for the part numbers of Polaris products.

1. Position the vehicle on a level surface.
2. Remove the fill plug.
3. View the oil level through the fill hole.
4. If the level is low, add the recommended oil.
5. Reinstall the fill plug.

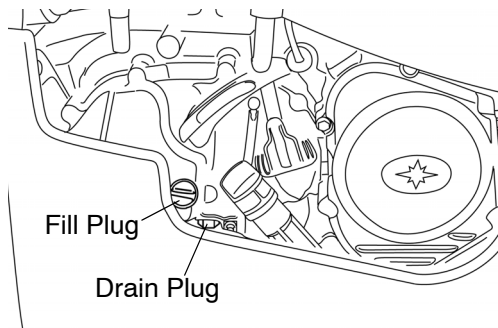

### Transmission Oil Change

1. Position the vehicle on a level surface.
2. Remove the fill plug.
3. Place a drain pan under the gearcase.
4. Remove the drain plug. Allow the oil to drain completely.
5. Clean and reinstall the drain plug. Torque to 14 ft. lbs. (19 Nm).
6. Add the recommended oil. Maintain the oil level at the bottom of the fill plug hole threads.
7. Reinstall the fill plug. Check for leaks.
8. Dispose of used oil properly.

<b>Gearcase Capacity</b>	
Outlaw 90	11.8 oz. (350 ml)
Sportsman 90	11.8 oz. (350 ml)

## Maintenance

### Spark Plugs

Refer to the specifications section beginning on page 178 for spark plug and gap specifications.

#### **CAUTION**

Using non-recommended spark plugs can result in serious engine damage. Always use Polaris-recommended spark plugs.

Spark plug condition is indicative of engine operation. The spark plug firing end condition should be read after the engine has been warmed up and the vehicle has been driven at higher speeds. Immediately check the spark plug for correct color.

#### **⚠ WARNING**

A hot exhaust system and engine can cause serious burns. Wear protective gloves when removing a spark plug for inspection.

## Spark Plugs

### Normal Plug

The normal insulator tip is gray, tan or light brown. There will be few combustion deposits. The electrodes are not burned or eroded. This indicates the proper type and heat range for the engine and the service.

**NOTE:** The tip should not be white. A white insulator tip indicates overheating, caused by use of an improper spark plug or incorrect carburetor/throttle body adjustments.

### Wet Fouled Plug

The wet fouled insulator tip is black. A damp oil film covers the firing end. There may be a carbon layer over the entire nose. Generally, the electrodes are not worn. General causes of fouling are excessive oil, use of non-recommended injection oil, improper use of the choke, or incorrect carburetion adjustments.

### Spark Plug Change

1. Remove the spark plug cap.
2. Using the special wrench provided in the tool pouch, rotate the spark plug counterclockwise to remove it.
3. Reverse the procedure for spark plug installation. Torque to 14 ft. lbs. (19 Nm).



## Maintenance

### Cylinder Head Torque

Have your dealer check the ATV cylinder head for proper torque at the first service, or after 25 hours.

### Vehicle Immersion

<b>CAUTION</b>
----------------

If your vehicle becomes immersed, major engine damage can result if the vehicle is not thoroughly inspected. Take the vehicle to your dealer before starting the engine.
--

If it's impossible to take your ATV to a dealer before starting it, follow the steps outlined below.

1. Move the ATV to dry land or at the very least, to water below the footrests.
2. Turn the fuel valve off.
3. Check the air box for any water and dry it if water is present.
4. Remove the spark plug.

### Vehicle Immersion

5. Loosen the carburetor drain screw.
6. Turn the engine over several times using the electric start.
7. Dry the spark plug and reinstall it, or replace it with a new plug.
8. Tighten the carburetor drain screw.
9. Turn the fuel valve on.
10. Attempt to start the engine. If necessary, repeat the drying procedure.
11. Take the ATV to your dealer for service as soon as possible, whether you succeed in starting it or not.

**NOTE:** If water has been ingested into the transmission, follow the procedure on page 137 for drying the CVT.

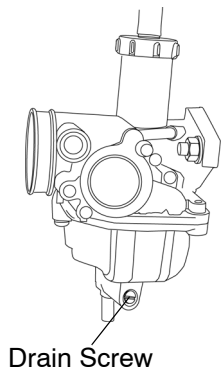

# Maintenance

## Constant Variable Transmission (CVT) System

### **WARNING**

Failure to comply with the instructions in this warning can result in severe injury or death.

Do not modify any component of the CVT system. Doing so may reduce its strength so that a failure may occur at a high speed. The CVT system has been precision balanced. Any modification will cause the system to be out of balance, creating vibration and additional loads on components.

The CVT system rotates at high speeds, creating large amounts of force on clutch components. Extensive engineering and testing has been conducted to ensure the safety of this product. However, as the owner, you have the following responsibilities to make sure this system remains safe:

Always follow all recommended maintenance procedures. See your dealer as outlined in the owner's manual.

This CVT system is intended for use on Polaris products only. Do not install it in any other product.

Always make sure the CVT housing is securely in place during operation.

### CVT Drying

There may be some instances when water is accidentally ingested into the CVT system. Use the following instructions to dry it out before operating. The drain plug is located on the bottom of the CVT cover.

1. Remove the drain plug. Allow the water to drain. Reinstall the drain plug.
2. Shift the transmission to neutral.
3. Start the engine. Apply varying throttle for 10-15 seconds to expel the moisture and air-dry the belt and clutches. Do not hold the throttle wide open for more than 10 seconds.
4. Allow the engine RPM to settle to idle speed.
5. Test for belt slippage. If the belt slips, repeat the process.
6. Take the vehicle to your dealer for service as soon as possible.

### **CAUTION**

Exposure to salt water will cause corrosion to metal components. If your vehicle is operated in salt water areas, rinse it off frequently with fresh water.

## Maintenance

### Spark Arrestor

To remove accumulated carbon, clean the spark arrestor at the intervals recommended in the Periodic Maintenance Chart beginning on page 114.

#### **WARNING**

Failure to heed these warnings could result in serious injury or death.

Do not perform service on the spark arrestor while the system is hot. Allow components to cool sufficiently before proceeding.

Wear eye protection and gloves.

Never run the engine in an enclosed area. Exhaust contains poisonous carbon monoxide gas.

### Spark Arrestor

1. Remove the six bolts and remove the arrestor from the end of the muffler.
2. Use a non-synthetic brush to clean the arrestor screen. A synthetic brush may melt if components are warm. If necessary, blow debris from the screen with compressed air.
3. Inspect the screen for wear and damage. Replace the arrestor if damage is found.
4. Reinstall the arrestor.
5. Torque the bolts to 7 ft. lbs. (9.5 Nm).



# Maintenance

## Carburetor

**IMPORTANT:** Your Polaris ATV is calibrated at the factory for optimal performance at altitudes ranging from zero to 6,000 feet (1800 m) and temperatures of +40 degrees F. (4 degrees C.) or higher. Above 6000 feet (1800 m) the engine air/fuel mixture becomes overly rich and the engine loses approximately 3% of its power for each 1000-foot (304.8 m) increase in elevation. Although this power cannot be regained, adjustments to the carburetor and drive system can be made to allow more efficient operation. Optional jets, available from your Polaris dealer, are required for operation above 6,000 feet and temperatures below +40 degrees F. (4 degrees C.).

**NOTE:** Continuous operation of the engine without proper jetting when required can cause poor performance, overheating or engine damage. See your Polaris dealer for more information about jetting the ATV for conditions in your area.

### Carburetor

If the engine idle speed is not satisfactory, and all other conditions are favorable, the carburetor can be adjusted.

1. Start the engine.
2. Lock the parking brake.
3. Allow the engine to run for approximately five minutes.
4. Adjust the carburetor idle screw either in or out until the desired idle RPM is reached. Turning the screw in (clockwise) will raise RPM. Turning the screw out (counterclockwise) will lower RPM.



## Maintenance

### Speed Control System

Per ANSI / SVIA-1-2001 (sec. 6.1.3) AS DELIVERED TO THE CONSUMER, the speed of youth models is restricted to *under* 10 MPH for the 50cc models and *under* 15 MPH for the 90cc models.

*The dealer CANNOT, under any circumstances, either prior to the sale or later, even at the consumer's request, remove or adjust any speed limiting devices.*

Your Polaris ATV has an adjustable throttle limiting screw. Speed limiting devices may be adjusted/removed *only by consumers* when they determine that their child is capable of handling the additional speed.

Per ANSI / SVIA-1-2001 (sec. 6.2) the *unrestricted* top speed is less than 15 MPH for the 50cc models and less than 30 MPH for the 90cc models.

## Speed Control System

### Throttle Stop Speed Control System

Use the following procedure to control how far the throttle opens.

1. Loosen the jam nut.
2. Turn the screw inward to reduce speed or outward to increase speed.
3. Tighten the jam nut after adjusting.

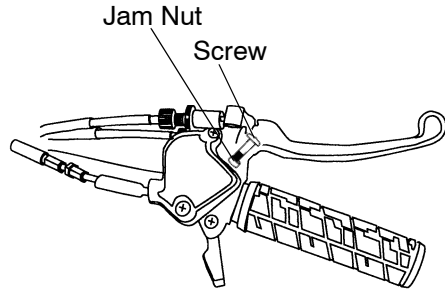

# Maintenance

## Throttle Cable Adjustment

Always check the throttle for smooth operation before riding. Periodically check the throttle freeplay. It should be kept between 1/16" and 1/8" (1.5 - 3.2 mm). If adjustment is required, turn the adjustment nut until the freeplay falls in to the acceptable limit.

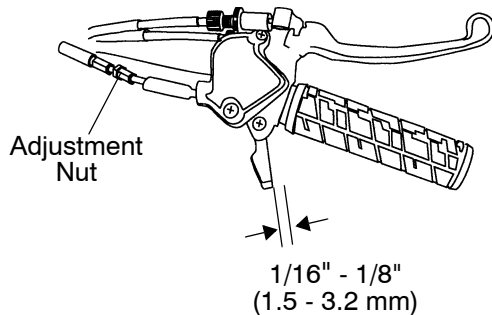

## Maintenance

### Brake Freeplay

Check (measure) the freeplay of the front and rear brakes at the intervals recommended in the Periodic Maintenance Chart beginning on page 114. If the freeplay isn't at specification, adjust the freeplay as outlined on the following pages.

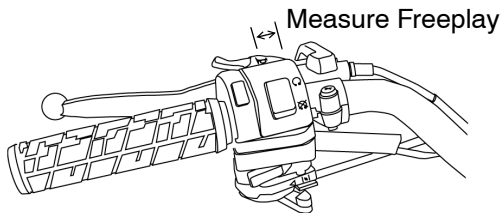

### Brake Freeplay Specifications

Model	Front Brake	Rear Brake
90cc Models	.08"-.12" (2-3 mm)	.08"-.12" (2-3 mm)

# Maintenance

## Brake Freeplay

### Front Brake Adjustment

1. Position the vehicle on a level surface.
2. Shift the transmission to neutral.
3. Elevate the front of the vehicle by placing a suitable stand under the frame. The front tires should be slightly off the ground.
4. While rotating the *left* front wheel, tighten the *upper* front brake adjuster nut on the right-hand control.
5. When you begin to feel a slight drag in wheel rotation, loosen the adjuster nut one full turn.

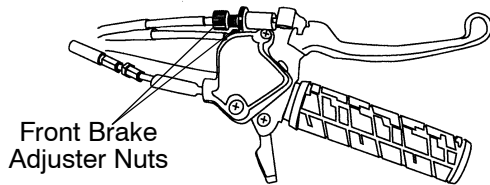

### Brake Freeplay

#### Front Brake Adjustment

6. While rotating the *right* front wheel, tighten the *lower* front brake adjuster nut on the right-hand control.
7. When you begin to feel a slight drag in wheel rotation, loosen the adjuster nut one full turn.
8. Verify that the right-hand brake functions correctly.
9. Verify that brake lever freeplay is at specification. See page 145.
10. Carefully lower the vehicle to the ground.

# Maintenance

## Brake Freeplay

### Rear Brake Adjustment

1. Position the vehicle on a level surface.
2. Shift the transmission to neutral.
3. Elevate the rear of the vehicle by placing a suitable stand under the frame. The rear tires should be slightly off the ground.
4. While rotating the rear wheels, tighten the rear brake wing nut at the rear brake drum.
5. When you begin to feel a slight drag in wheel rotation, loosen the wing nut one full turn.
6. Verify that the left hand brake functions correctly.
7. Verify that brake lever freeplay is at specification. See page 145.
8. Carefully lower the vehicle to the ground.

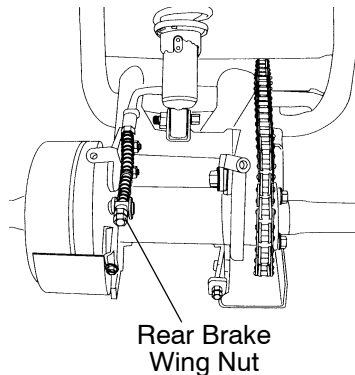

## Brake Lever Travel

Check brake lever travel at the intervals recommended in the Periodic Maintenance Chart beginning on page 114. When freeplay specifications can no longer be obtained through adjustment as outlined on the preceding pages, use the following information to determine when to service the brakes.

Service the brakes when brake lever travel reaches the total lever travel measurement listed in the table below. Always service the brakes when there is no longer sufficient stopping ability at the specified lever travel setting.

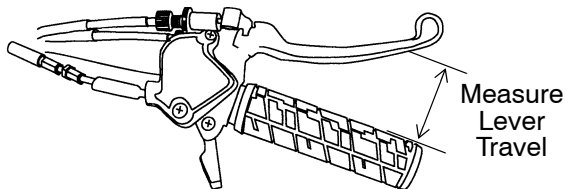

Component	Total Lever Travel
Front brake lever	1 3/4" (45 mm)
Rear brake lever	2 1/2" (65 mm)



## Maintenance

### Toe Alignment

#### **WARNING**

Severe injury or death can result from improper toe alignment and adjustment. Do not attempt to adjust tie rod alignment. All tie rod adjustments should be performed by an authorized Polaris dealer.

Use the following procedure to check the toe alignment of the vehicle. The recommended toe alignment is 1/8" to 1/4" (3-6 mm) toe out.

1. Set the handlebars in a straight-ahead position.

**NOTE:** The steering frog can be used as an indicator of whether the handlebars are straight. The frog should always point straight back from the steering post.

2. Place stands in front of the vehicle, perpendicular to the rear tires.

### Toe Alignment

3. Tie an elastic string around the stands, making sure the string just touches the side surface of the rear tires on each side of the vehicle and goes around the stands in front of the vehicle.
4. Measure the distance from the string to the rim at the front and rear of the front rim. Rear measurement should be  $\frac{1}{16}$ " -  $\frac{1}{8}$ " (2-3 mm) more than the front measurement.

**NOTE:** If you discover improper alignment, see your Polaris dealer for service.

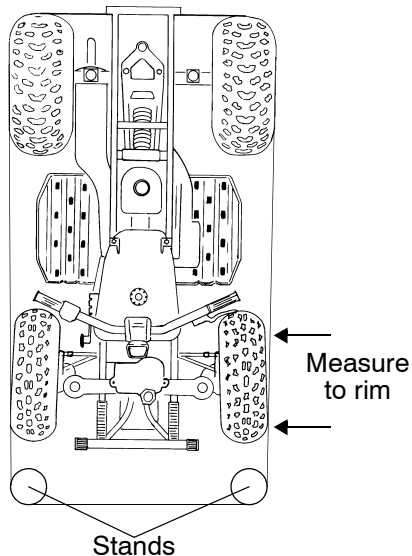

## Maintenance

### Steering Inspection

Check the steering assembly periodically for loose nuts and bolts. If any are found, have your dealer tighten them before operating the ATV.

### Camber and Caster

The camber and caster are non-adjustable.

### Shock Spring Adjustment

The front and rear shock absorber springs are adjustable to increase or decrease spring tension. Rotate the adjuster either clockwise or counter-clockwise to make adjustments.

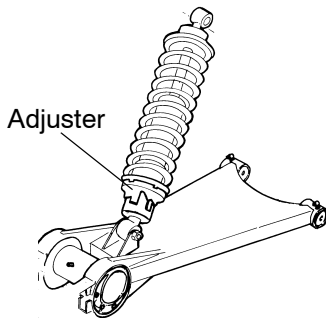

### Drive Chain

Lubricate the drive chain with Polaris chain spray lube or an approved chain lube at the general lubrication interval specified in the Periodic Maintenance Chart beginning on page 114. Lubricate more often under severe use, such as in dirty or wet conditions. See page 182 for the part numbers of Polaris products.

#### **CAUTION**

Washing the drive chain with a high pressure washer or gasoline can cause premature wear and drive chain failure. Don't use a high pressure washer or gasoline to clean the drive chain.

#### **CAUTION**

Adjusting or operating the ATV with improper rear drive chain slack can result in severe damage to the transmission and drive components. Always make sure the slack is within the stated specifications.

# Maintenance

## Drive Chain Slack

1. Check the amount of chain slack by moving the vehicle slightly forward to gain slack at the top side of the chain.
2. Collapse the suspension with an adjustable (buckle type) trailer tie-down strap. Fasten the strap around the axle and rear bumper tube.
3. Tighten the strap until a straight line can be drawn from the rear axle to the gearcase output shaft intersecting the swing arm pivot. This establishes the tightest chain position.
4. Pull down on the chain tensioner to move it out of the way, then measure chain slack. It should have 1/4"-1/2" (6-12 mm) deflection.
5. If the chain needs adjustment, use the procedure on page 155.

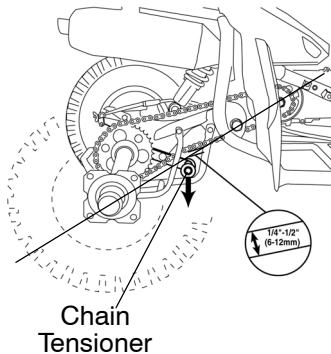

## Drive Chain Slack Adjustment

### CAUTION

Hold the adjuster stud securely while tightening the jam nuts to avoid breaking the stud.

1. Loosen the four rear housing mount bolts.
2. Loosen the chain adjuster lock nut.
3. Turn the chain adjuster clockwise to 1/4"-1/2" (6-12 mm) deflection.
4. Tighten the chain adjuster lock nut to 18 ft. lbs. (25 Nm).
5. Tighten the four rear housing mount bolts to 43 ft. lbs. (60 Nm).

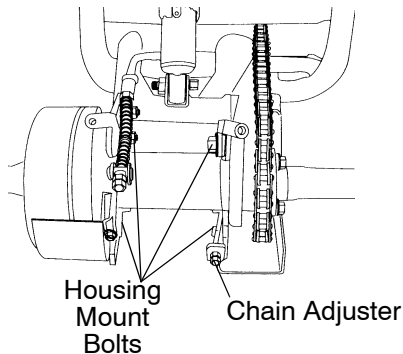

# Maintenance

## Air Filter

1. Remove the seat. See page 21.
2. Release the air box cover spring clips and remove the cover.
3. Remove the foam air filter. Wash the foam filter in warm soapy water, then rinse and let dry. If the filter is damaged, install a new foam filter.
4. Apply a commercially available foam filter lubricant to the foam filter.



Clips

Cover



Foam Filter



Support Screen

### Air Filter

5. Clean away any oil or sediments in the air box.
6. Reinstall the filter and air box cover. Secure the clips.
7. Reinstall the seat.

### CAUTION

Never operate the ATV with the filter element removed. Dirt will enter the engine causing rapid wear and severe damage to the engine.



# Maintenance

## Handlebar Adjustment

### **⚠ WARNING**

Improper adjustment of the handlebars or incorrect torquing of the adjuster block tightening bolts can cause limited steering or loosening of the handlebars, resulting in loss of control and possible serious personal injury or death. Follow the adjustment procedures exactly, or see your Polaris dealer for service.

The handlebars can be adjusted for rider preference.

1. Remove the pod to access the handlebar bolts.  
Loosen the four bolts.
2. Adjust the handlebar to the desired height. Be sure the handlebars do not hit the gas tank or any other part of the vehicle when turned fully to the left or right.
3. Lightly tighten each bolt equally to prevent uneven gaps in the block. Torque the bolts to 7.3 ft. lbs. (10 Nm).

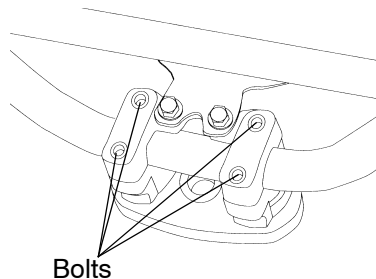

### Tires

#### **WARNING**

Operating your ATV with worn tires, improperly inflated tires, non-standard tires or improperly installed tires will affect vehicle handling and could cause an accident resulting in serious injury or death.

Maintain proper tire pressure as described on the decal on your ATV and in the owner's manual.

Always use original equipment size and type when replacing tires.

Make sure the wheels are installed properly.

Always replace tires when the tread depth measures 1/8" (3 mm) or less.

## Maintenance

### Tire Tread Depth

Always replace tires when tread depth is worn to 1/8" (3 mm) or less.

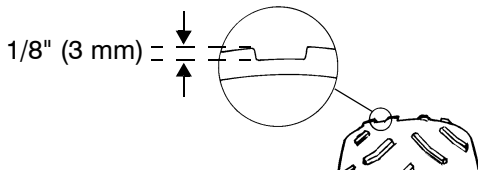

### Wheel Removal

1. Stop the engine and lock the parking brake.
2. Loosen the wheel bolts slightly.
3. Elevate the side of the vehicle by placing a suitable stand under the footrest frame.
4. Remove the wheel bolts and remove the wheel.

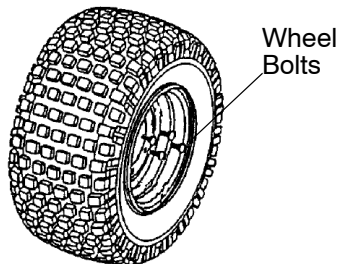

### Wheel Installation

1. Lock the parking brake.
2. Place the wheel in the correct position on the wheel hub. Be sure the valve stem is toward the outside and rotation arrows on the tire point toward forward rotation.
3. Install the wheel bolts and finger tighten them.
4. Lower the vehicle to the ground.
5. Securely tighten the bolts to 22 ft. lbs. (30 Nm).

## **Maintenance**

### **Axle and Wheel Nuts**

All nuts with a cotter pin installed must be service by an authorized Polaris dealer.

### **Wheel Hub Tightening**

Front wheel bearing tightness and spindle nut retention are critical component operations. All service must be performed by your authorized Polaris dealer.

### Tail Light Lamp Replacement

If the brakelight doesn't work, the lamp may need to be replaced.

1. Remove the two screws securing the lens cover. Remove the lens cover.
2. Remove the lamp and replace it with a new recommended lamp.
3. Test the light for proper operation.
4. Reinstall the lens cover.

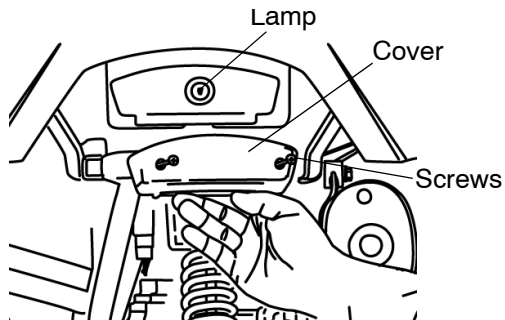

## **Maintenance**

### **Indicator Light Lamp Replacement**

1. Remove the handlebar cover or pod to access the lamps.
2. Remove the indicator wire connections from the harness.
3. Remove the nut from the back side of the indicator lamp.
4. Remove the lamp.
5. Apply dielectric grease to the socket and install the new lamp.
6. Reverse the steps to reinstall all components.

### Daytime Running Lights Lamp Replacement (if equipped)

If the daytime running lights do not operate, replace the lamps. Polaris recommends that you install replacement lamps obtained from your authorized Polaris dealer.

1. Remove the front cab (Outlaw only).
2. Disconnect the lights from the harness.
3. Remove the rubber cover from the back of the light assembly.
4. Press the lamp retainer inward and turn it counter-clockwise to remove it. Note the position of the lamp positioning tab, then carefully pull the lamp out.
5. Install the new lamp. Make sure the filament is horizontal.
6. Reinstall the lamp retainer. Press the retainer inward and turn it clockwise about 1/4 turn.
7. Start the engine to make sure the lights come on. If the lights do not operate, see your Polaris dealer for service.
8. Reinstall the rubber cover, and reconnect the lights to the harness.
9. Reinstall the front cab (Outlaw only).



## Maintenance

### Battery

The battery in your Polaris ATV is a sealed battery. The sealing strip cannot be removed. Never add water to this type of battery.

Keep the battery terminals and connections free of corrosion. If cleaning is necessary, remove the corrosion with a stiff wire brush. Wash with a solution of one tablespoon baking soda and one cup water. Rinse well with tap water and dry off with clean shop towels. Coat the terminals with dielectric grease or petroleum jelly.

#### **WARNING**

Improperly connecting or disconnecting battery cables can result in an explosion and cause serious injury or death. When removing the battery, always disconnect the negative (black) cable first. When reinstalling the battery, always connect the negative (black) cable last.

### Battery

#### Battery Removal

1. Disconnect the hold-down straps securing the electrical box and battery in position.
2. Disconnect the black (negative) battery cable first.
3. Disconnect the red (positive) battery cable next.
4. Lift the battery out of the ATV.

# Maintenance

## Battery

### Battery Installation and Connections

1. Set the battery in its holder.
2. Connect and tighten the red (positive) cable first.
3. Connect and tighten the black (negative) cable last.
4. Attach the hold-down strap.
5. Verify that cables are properly routed.

**NOTE:** When installing a new battery, make sure it's fully charged prior to its initial use. Using a new battery that has not been fully charged can damage the battery and result in a shorter life. It can also hinder vehicle performance. If recharging is necessary, use a .5 amp battery charger.

### Battery Storage

Whenever the vehicle is not used for a period of three months or more, remove the battery from the vehicle, ensure that it's fully charged, and store it out of the sun in a cool, dry place. Check battery voltage each month during storage and recharge as needed to maintain a full charge.

### Cleaning

Keeping your ATV clean will not only improve its appearance but it can also extend the life of various components.

#### **CAUTION**

High water pressure may damage components. Polaris recommends washing the vehicle by hand or with a garden hose, using mild soap.

Certain products, including insect repellents and chemicals, will damage plastic surfaces. Do not allow these types of products to contact the vehicle.

# Maintenance

## Cleaning

### Washing the ATV

The best and safest way to clean your Polaris vehicle is with a garden hose and a pail of mild soap and water.

1. Use a professional-type washing cloth, cleaning the upper body first and the lower parts last.
2. Rinse with clean water frequently.
3. Dry surfaces with a chamois to prevent water spots.

### Washing Tips

- Avoid the use of harsh cleaners, which can scratch the finish.
- Do not use a power washer to clean the vehicle.
- Do not use medium to heavy duty compounds on the finish.
- Always use clean cloths and pads for cleaning and polishing. Old or reused cloths and pads may contain dirt particles that will scratch the finish.

## Cleaning

### Washing the ATV

If a high pressure water system is used for cleaning (not recommended), exercise extreme caution. The water may damage components and could remove paint and decals. Avoid directing the water stream at the following items:

- Wheel bearings
- Radiator
- Transmission seals
- Brakes
- Cab and body panels
- Labels and decals

**NOTE:** If warning and safety labels are damaged, contact your Polaris dealer for free replacement.

Grease all zerk fittings immediately after washing. Allow the engine to run for a while to evaporate any water that may have entered the engine or exhaust system.

## **Maintenance**

### **Polishing**

Polaris recommends the use of common household aerosol furniture polish for polishing the finish on your Polaris vehicle. Follow the instructions on the container.

#### **Polishing Tips**

- Avoid the use of automotive products, some of which can scratch the finish of your vehicle.
- Always use clean cloths and pads for cleaning and polishing. Old or reused cloths and pads may contain dirt particles that will scratch the finish.

### Storage

#### Exterior

Make necessary repairs and clean the vehicle as recommended. See page 169.

#### Battery Storage

Remove the battery from the vehicle, ensure that it's fully charged, and store it out of the sun in a cool, dry place. Check battery voltage each month during storage and recharge as needed to maintain a full charge.



# Maintenance

## Storage

### Stabilize the Fuel

Polaris Carbon Clean is a fuel stabilizer and fuel system dryer. It cleans the fuel system, the combustion chamber and the exhaust ports. It also prevents bacterial growth and promotes better starting after the storage period.

1. Fill the fuel tank.
2. Add Polaris Carbon Clean Fuel Treatment or Polaris Fuel Stabilizer. Follow the instructions on the container for the recommended amount.

**NOTE:** Carbon clean will also reduce the possibility of bacterial growth in the fuel system.

3. Start the engine and allow it to run for 15-20 minutes so the stabilizer can disperse through the fuel in the tank and carburetor.
4. Stop the engine.
5. Turn the fuel valve off.
6. Drain the carburetor bowl.

## Storage

### Engine Oil

Change the oil. See page 126.

### Air Filter / Air Box

Inspect and clean (or replace) the pre-cleaner and air filter. Clean the air box. Drain the sediment tube.

### Fluid Levels

Inspect fluid levels. Change fluids as recommended in the Periodic Maintenance Chart beginning on page 114.

- Transmission Oil
- Engine Oil
- Brake Fluid

# Maintenance

## Storage

### Lubricate

Inspect all cables and lubricate all areas of the vehicle as recommended in the Periodic Maintenance Chart beginning on page 114.

### Storage Area/Covers

1. Make sure tire pressure is at specification.
2. Using suitable supports under the frame, raise the vehicle slightly so that the tires are not touching the ground.
3. Be sure the storage area is well ventilated.
4. Cover the vehicle with an appropriate cover.

**NOTE:** Do not use plastic or coated materials. They do not allow enough ventilation to prevent condensation, and may promote corrosion and oxidation.

### Transporting the ATV

Follow these procedures when transporting the ATV.

1. Stop the engine.
2. Place the transmission in gear.
3. Lock the parking brake.
4. Secure the fuel cap, oil cap and seat.
5. Turn the fuel valve off.
6. Always tie the frame of the ATV to the transporting unit securely with suitable straps or rope. The rack, bumper or handlebars do not offer enough support for tie-down while transporting the unit.

### Accessories

Polaris has a wide range of accessories available for your ATV. Please see your Polaris dealer.

## Specifications

<b>Outlaw 90</b>	
Rider Capacity/Maximum Weight	1 Rider/170 lbs. (77 kg)
Displacement	89cc
Cooling	Air Cooled
Engine type	4-Stroke
Lubrication	Wet Sump
Oil Capacity	30 oz. (900 ml)
Fuel Capacity	1.7 gallons (6.4 liters)
Fuel Reserve Capacity	.23 gallons (.86 liters)
Starting	Electric with kick-start backup
Drive System	Automatic CVT
Final Drive	Chain
Front Suspension	Single A-arm with 5" (12.7 cm) of travel
Rear Suspension	Swing arm with 6" (15.2 cm) of travel

## Specifications

<b>Outlaw 90</b>	
Front/Rear Brakes	Drum
Parking Brake	Mechanical Lock
Front Tires	19 x 7 - 8 (3 psi)
Rear Tires	18 x 9.5 - 8 (3 psi)
Dry Weight	270 lbs. (122.4 kg)
Length/Width/Height	61.25" (156 cm) / 36.75" (93 cm) / 38.5" (98 cm)
Wheel Base	41.5" (105 cm)
Ground Clearance	4" (10 cm) at swing arm, 7.7" (19.5 cm) at frame
Brake Light	Standard
Daytime Running Lights	Standard

## Specifications

<b>Sportsman 90</b>	
Rider Capacity/Maximum Weight	1 Rider/170 lbs. (77 kg)
Displacement	89cc
Cooling	Air Cooled
Engine type	4-Stroke
Lubrication	Wet Sump
Oil Capacity	30 oz. (900 ml)
Fuel Capacity	2 gallons (7.7 liters)
Fuel Reserve Capacity	.22 gallons (.85 liters)
Starting	Electric with kick-start backup
Drive System	Automatic CVT
Final Drive	Chain
Front Suspension	Single A-arm with 5" (12.7 cm) of travel
Rear Suspension	Swing arm with 6" (15.2 cm) of travel

## Specifications

<b>Sportsman 90</b>	
Front Rack Capacity	15 lbs. (6.8 kg)
Rear Rack Capacity	30 lbs. (13.6 kg)
Front/Rear Brakes	Drum
Parking Brake	Mechanical Lock
Front Tires	19 x 7 - 8 (3 psi)
Rear Tires	18 x 9.5 - 8 (3 psi)
Dry Weight	289 lbs. (131 kg)
Length/Width/Height	61.75" (157 cm) / 36.75" (93 cm) / 38.5" (98 cm)
Wheel Base	41.5" (105 cm)
Ground Clearance	4" (10 cm) at swing arm, 7.7" (19.5 cm) at frame
Brake Light	Standard
Daytime Running Lights	Standard



## Polaris Products

Part Number	Description
<b>Engine Lubricant</b>	
2876248	Synthetic Youth Oil (qt/.95 l)
2876249	Synthetic Youth Oil (gal/3.8 l)
2872175	Semi-Synthetic 20W-40 Oil (qt/.95 l)
2872176	Semi-Synthetic 20W-40 Oil (gal/3.8 l)
2870791	Fogging Oil, Aerosol
<b>Gearcase / Transmission Lubricants</b>	
2873602	Premium AGL Synthetic Gearcase Lubricant (qt/.95 l)
2872348	Chain Lube, Aerosol

## Polaris Products

Part Number	Description
<b>Grease</b>	
2871322	All Season Premium Grease (3 oz./89 ml)
2871423	All Season Premium Grease (14 oz./414 ml)
<b>Miscellaneous Additives</b>	
2871326	Carbon Clean Plus

## Troubleshooting

See your Polaris dealer if you're unable to identify solutions using the following charts.

### Engine Turns Over, Fails to Start

Possible Cause	Solution
Out of fuel	Turn the fuel valve to reserve, refuel
Clogged fuel valve or filter	Inspect and clean or replace
Water is present in fuel	Drain the fuel system and refuel
Fuel valve is turned off	Turn the fuel valve on
Old or non-recommended fuel	Replace with new fuel
Fouled or defective spark plug(s)	Inspect plug(s), replace if necessary
No spark to spark plug	Inspect plug(s), verify stop switch is on
Crankcase filled with water or fuel	Immediately see your Polaris dealer
Overuse of choke	Inspect, clean and/or replace spark plugs
Clogged fuel filter	Replace the filter
Low battery voltage	Recharge battery with .5 amp charger
Mechanical failure	See your Polaris dealer

# Troubleshooting

## Engine Doesn't Turn Over

Possible Cause	Solution
Low battery voltage	Recharge battery with .5 amp charger
Loose battery connections	Check all connections and tighten
Loose solenoid connections	Check all connections and tighten

## Engine Pings or Knocks

Possible Cause	Solution
Poor quality or low octane fuel	Replace with recommended fuel
Incorrect ignition timing	See your Polaris dealer
Incorrect spark plug gap or heat range	Set gap to specs or replace plugs

## Troubleshooting Engine Backfires

<b>Possible Cause</b>	<b>Solution</b>
Weak spark from spark plugs	Inspect, clean and/or replace spark plugs
Incorrect spark plug gap or heat range	Set gap to specs or replace plugs
Old or non-recommended fuel	Replace with new fuel
Incorrectly installed spark plug wires	See your Polaris dealer
Incorrect ignition timing	See your Polaris dealer
Mechanical failure	See your Polaris dealer
Exhaust system leak	See your Polaris dealer

## Troubleshooting

### Engine Runs Irregularly, Stalls or Misfires

Possible Cause	Solution
Fouled or defective spark plugs	Inspect, clean and/or replace spark plugs
Worn or defective spark plug wires	See your Polaris dealer
Incorrect spark plug gap or heat range	Set gap to specs or replace plugs
Loose ignition connections	Check all connections and tighten
Water present in fuel	Replace with new fuel
Low battery voltage	Recharge battery with .5 amp charger
Kinked or plugged fuel vent line	Inspect and replace
Incorrect fuel	Replace with recommended fuel
Clogged air filter	Inspect and clean or replace
Electronic throttle control malfunction	See your Polaris dealer
Other mechanical failure	See your Polaris dealer

## Troubleshooting

### Engine Runs Irregularly, Stalls or Misfires

<b>Possible Lean Fuel Mixture Cause</b>	<b>Solution</b>
Low or contaminated fuel	Add or change fuel, clean the fuel system
Low octane fuel	Replace with recommended fuel
Clogged fuel filter	Replace filter
Incorrect jetting	See your Polaris dealer
<b>Possible Rich Fuel Mixture Cause</b>	<b>Solution</b>
Overuse of choke	Inspect, clean and/or replace spark plugs
Fuel is very high octane	Replace with lower octane fuel
Incorrect jetting	See your Polaris dealer

# Troubleshooting

## Engine Stops or Loses Power

Possible Cause	Solution
Out of fuel	Turn the fuel valve to reserve, refuel
Kinked or plugged fuel vent line	Inspect and replace
Water present in fuel	Replace with new fuel
Overuse of choke	Inspect, clean and/or replace spark plugs
Fouled or defective spark plugs	Inspect, clean and/or replace spark plugs
Worn or defective spark plug wires	See your Polaris dealer
Incorrect spark plug gap or heat range	Set gap to specs or replace plugs
Loose ignition connections	Check all connections and tighten
Low battery voltage	Recharge battery with .5 amp charger
Incorrect fuel	Replace with recommended fuel
Clogged air filter	Inspect and clean or replace
Electronic throttle control malfunction	See your Polaris dealer
Other mechanical failure	See your Polaris dealer



# Warranty

## LIMITED WARRANTY

Polaris Sales Inc., 2100 Highway 55, Medina, MN 55340, gives a SIX MONTH LIMITED WARRANTY on all components of the Polaris All Terrain Vehicle (ATV) against defects in material or workmanship. Polaris also gives a one year limited warranty on the final drive chain for failure due to defects. This warranty covers the parts and labor charges for repair or replacement of defective parts which are covered by this warranty. This warranty begins on the date of purchase. This warranty is transferable to another consumer during the warranty period through a Polaris dealer.

## REGISTRATION

At the time of sale, the Warranty Registration Form must be completed by your dealer and submitted to Polaris within ten days. Upon receipt of this registration, Polaris will record the registration for warranty. No verification of registration will be sent to the purchaser as the copy of the Warranty Registration Form will be the warranty entitlement. If you have not signed the original registration and received the “customer copy”, please contact your dealer immediately. **NO WARRANTY COVERAGE WILL BE ALLOWED UNLESS YOUR ATV IS REGISTERED WITH POLARIS.**

Initial dealer preparation and set-up of your ATV is very important in ensuring trouble-free operation. Purchasing a machine in the crate or without proper dealer set-up will void your warranty coverage.

## **WARRANTY COVERAGE AND EXCLUSIONS: LIMITATIONS OF WARRANTIES AND REMEDIES**

The Polaris limited warranty excludes any failures that are not caused by a defect in material or workmanship. This warranty does not cover accidental damage, normal wear and tear, abuse or improper handling. This warranty also does not cover any ATV that has been altered structurally, modified, neglected, improperly maintained, used for racing, or used for purposes other than for which it was manufactured, or for any damages which occur during trailer transit or as a result of unauthorized service or the use of unauthorized parts. In addition, this warranty does not cover physical damage to paint or finish, stress cracks, tearing or puncturing of upholstery material, corrosion, or defects in parts, components or the ATV due to fire, explosions or any other cause beyond Polaris' control.

This warranty does not cover the use of unauthorized lubricants, chemicals, or fuels that are not compatible with the ATV. The exclusive remedy for breach of this warranty shall be, at Polaris' exclusive option, repair or replacement of any defective materials, or components or products. **THE REMEDIES SET FORTH IN THIS WARRANTY ARE THE ONLY REMEDIES AVAILABLE TO ANY PERSON FOR BREACH OF THIS WARRANTY. POLARIS SHALL HAVE NO LIABILITY TO ANY PERSON FOR INCIDENTAL, CONSEQUENTIAL OR SPECIAL DAMAGES OF ANY DESCRIPTION, WHETHER ARISING OUT OF EXPRESS OR IMPLIED WARRANTY OR ANY OTHER CONTRACT, NEGLIGENCE, OR OTHER TORT OR OTHERWISE.** Some states do not permit the exclusion or limitation of incidental or consequential damages or implied warranties, so the above limitations or exclusions may not apply to you if inconsistent with controlling state law.

# Warranty

## **WARRANTY COVERAGE AND EXCLUSIONS:**

### **LIMITATIONS OF WARRANTIES AND REMEDIES**

ALL IMPLIED WARRANTIES (INCLUDING BUT NOT LIMITED TO THE IMPLIED WARRANTIES OF MERCHANTABILITY AND FITNESS FOR A PARTICULAR PURPOSE) ARE LIMITED IN DURATION TO THE ABOVE SIX MONTH WARRANTY PERIOD. POLARIS FURTHER DISCLAIMS ALL EXPRESS WARRANTIES NOT STATED IN THIS WARRANTY. Some states do not allow limitations on how long an implied warranty lasts, so the above limitation may not apply to you if inconsistent with controlling state law.

## HOW TO OBTAIN WARRANTY SERVICE

If your ATV requires warranty service, you must take it to a Polaris dealer authorized to repair Polaris ATVs. When requesting warranty service you must present your copy of the Warranty Registration form to the dealer. (THE COST OF TRANSPORTATION TO AND FROM THE DEALER IS YOUR RESPONSIBILITY). Polaris suggests that you use your original selling dealer; however, you may use any Polaris Servicing Dealer to perform warranty service.

Please work with your dealer to resolve any warranty issues. Should your dealer require any additional assistance they will contact the appropriate personnel at Polaris.

This warranty gives you specific legal rights, and you may also have other rights which vary from state to state.

If any of the above terms are void because of state or federal law, all other warranty terms will remain in effect.

### **Recommended Lubricants**

1. Mixing oil brands or using non-recommended oil may cause engine damage. We recommend the use of Polaris engine oil.
2. Damage resulting from the use of non-recommended lubricants may not be covered by warranty.

# Warranty

## EXPORTED VEHICLES

EXCEPT WHERE SPECIFICALLY REQUIRED BY LAW, THERE IS NO WARRANTY OR SERVICE BULLETIN COVERAGE ON THIS VEHICLE IF IT IS SOLD OUTSIDE THE COUNTRY OF THE SELLING DEALER'S AUTHORIZED LOCATION.

This policy does not apply to vehicles that have received authorization for export from Polaris Industries. Dealers may not give authorization for export. You should consult an authorized dealer to determine this vehicle's warranty or service bulletin coverage if you have any questions.

This policy does not apply to vehicles registered to government officials or military personnel on assignment outside the country of the selling dealer's authorized location.

This policy does not apply to Safety Recalls.

### How to Get Service

#### *In the country where your vehicle was purchased:*

Warranty or Service Bulletin repairs must be done by an authorized Polaris dealer. If you move or are traveling within the country where your vehicle was purchased, Warranty or Service Bulletin repairs may be requested from any authorized Polaris dealer who sells the same line as your vehicle.

#### *Outside the country where your vehicle was purchased:*

If you are traveling temporarily outside the country where your vehicle was purchased, you should take your vehicle to an authorized Polaris dealer. You must show the dealer photo identification from the country of the selling dealer's authorized location as proof of residence. Upon residence verification, the servicing dealer will be authorized to perform the warranty repair.

## EXPORTED VEHICLES

### How to Get Service

#### *If You Move:*

If you move to another country, be sure to contact Polaris Customer Assistance and the customs department of the destination country before you move. Vehicles importation rules vary considerably from country to country. You may be required to present documentation of your move to Polaris Industries in order to continue your warranty coverage. You may also be required to obtain documentation from Polaris Industries in order to register your vehicle in your new country.

#### *If Purchased From A Private Party:*

If you purchase a Polaris product from a private citizen outside of the country in which the vehicle was originally purchased, all warranty coverage will be denied.

### Notice

If your vehicle is registered outside of the country where it was purchased, and you have not followed the procedure set out above, your vehicle will no longer be eligible for warranty or service bulletin coverage of any kind. (Vehicles registered to Government officials or military personnel on assignment outside of the country where the vehicle was purchased will continue to be covered by the basic warranty.)

#### *For questions call Polaris Customer Assistance:*

United States: 1-888-704-5290

Canada: 1-204-925-7100

# Warranty

## U.S.A. EPA Emissions Limited Warranty

This All Terrain Vehicle (ATV) or Off Road Utility Vehicle (ORUV) emissions limited warranty is in addition to the Polaris standard limited warranty for this vehicle.

Polaris warrants that this vehicle is; (1) designed, built, and equipped to conform at the time of initial sale with the requirements of 40 CFR 1051 and, (2) free from defects in materials and workmanship that may keep it from meeting these requirements.

The emissions warranty period for this vehicle begins on the date the vehicle is delivered to the original retail purchaser and ends 30 months (2.5 years) after that date.

This emission-related warranty covers components whose failure would increase an engine's emissions, including electronic controls, fuel injection, exhaust-gas recirculation, aftertreatment, or any other system utilized in this vehicle to control emissions. Replacing or repairing other components not covered by this emissions warranty or the standard warranty is the responsibility of the owner; including the parts, labor and other costs associated with recommended maintenance.

## U.S.A. EPA Emissions Limited Warranty

The exclusive remedy for breach of this limited warranty shall be, at the exclusive option of Polaris, repair or replacement of any defective materials, components or products. THE REMEDIES SET FORTH IN THIS LIMITED WARRANTY ARE THE ONLY REMEDIES AVAILABLE TO ANY PERSON FOR BREACH OF THIS WARRANTY. POLARIS SHALL HAVE NO LIABILITY TO ANY PERSON FOR INCIDENTAL, CONSEQUENTIAL OR SPECIAL DAMAGES OF ANY DESCRIPTION, WHETHER ARISING OUT OF EXPRESS OR IMPLIED WARRANTY OR ANY OTHER CONTRACT, NEGLIGENCE OR OTHER TORT OR OTHERWISE.

ALL IMPLIED WARRANTIES (INCLUDING BUT NOT LIMITED TO ANY IMPLIED WARRANTIES OF MERCHANTABILITY AND FITNESS FOR A PARTICULAR PURPOSE) ARE LIMITED IN DURATION TO THE WARRANTY PERIOD DESCRIBED HEREIN. POLARIS DISCLAIMS ALL EXPRESS WARRANTIES NOT STATED IN THIS WARRANTY. Some states do not allow limitations on how long an implied warranty lasts, so the above limitation may not apply if it is inconsistent with the controlling state law.

This limited warranty excludes failures not caused by a defect in material or workmanship. This limited warranty does not cover damage due to accidents, abuse or improper handling, maintenance or use. This limited warranty also does not cover any engine that has been structurally altered, or any engine that has been used in racing competition. This limited warranty also does not cover physical damage, corrosion or defects caused by fire, explosions or other similar causes beyond the control of Polaris.

If you have any questions regarding your warranty rights and responsibilities, you should contact the Polaris Warranty Department at 1-888-704-5290.



# Maintenance Log

Present this section of your manual to your dealer each time your vehicle is serviced. This will provide you and future owners with an accurate log of maintenance and services performed.

DATE	SERVICE INTERVAL	TECHNICIAN	SERVICE PERFORMED / COMMENTS
	<b>10 Hours (Break-in)</b>		
	<b>40 Hours</b>		
	<b>50 Hours</b>		
	<b>80 Hours</b>		

# Maintenance Log

<b>DATE</b>	<b>SERVICE INTERVAL</b>	<b>TECHNICIAN</b>	<b>SERVICE PERFORMED / COMMENTS</b>
	<b>100 Hours</b>		
	<b>120 Hours</b>		
	<b>150 Hours</b>		

# Maintenance Log

DATE	SERVICE INTERVAL	TECHNICIAN	SERVICE PERFORMED / COMMENTS

# Maintenance Log

DATE	SERVICE INTERVAL	TECHNICIAN	SERVICE PERFORMED / COMMENTS

# Index

## A

- Accessories . . . . . 177
- Age Warning . . . . . 36
- Air Filter . . . . . 156-157
- Axle and Wheel Nuts . . . . . 162

## B

### Battery

- Installation/Connections . . . 168
- Removal . . . . . 167
- Storage . . . . . 168, 173
- Boots . . . . . 93
- Brake Adjustment, Front . . . 146-147
- Brake Adjustment, Rear . . . . 148
- Brake Freeplay . . . . . 145-148
- Brake Freeplay Specifications . . 145
- Brake Lever Travel . . . . . 149
- Brake Levers . . . . . 22
- Brake, Parking . . . . . 75-76
- Brakes . . . . . 74-76
- Break-in Period . . . . . 83-84

## C

- Camber and Caster . . . . . 152
- Carburetor . . . . . 140-141
- Choke Lever . . . . . 68
- Cleaning . . . . . 169
- Clothing . . . . . 93
- Clutch Cover Warning . . . . . 41
- Constant Variable Transmission . 136
- CVT Drying . . . . . 137
- CVT System . . . . . 136
- Cylinder Head Torque . . . . . 134

## D

- Daytime Running Lights . . . . . 165
- Drive Chain . . . . . 153
- Drive Chain Slack . . . . . 154
- Drive Chain Slack Adjustment . . 155
- Driving Across Hillsides . . . 100-101
- Driving Downhill . . . . . 104
- Driving in Reverse . . . . . 109
- Driving on Slippery Surfaces . . 96-97
- Driving Over Obstacles . . . . . 108
- Driving Procedure . . . . . 94
- Driving Through Water . . . . 106-107
- Driving Uphill . . . . . 98-99

## E

- Electronic Throttle Control . . . . 71
- Emission Control Systems . . . 112-113
- Engine Start Button . . . . . 69
- Engine Stop Switch . . . . . 68
- Equipment Modifications . . . . . 15
- Eye Protection . . . . . 93

## F

- Fuel Filter . . . . . 129
- Fuel Stabilizer . . . . . 174
- Fuel System . . . . . 78-80
- Fuel Valve . . . . . 81

## G

- Gas Cap . . . . . 21, 80
- Gearcase Capacity . . . . . 131
- Gloves . . . . . 93

## H

- Handlebar Adjustment . . . . . 158
- Hauling Cargo . . . . . 110-111
- Helmet . . . . . 92
- Horn . . . . . 69
- Horn Button . . . . . 19

# Index

## I-J

- Indicator Light ..... 164
- Indicator Lights ..... 77

## K

- Key Switch ..... 67
- Kick-Start Lever ..... 20, 82
- K-Turn ..... 102

## L

### Lamp Replacement

- Daytime Running Lights .. 165
- Indicator Light ..... 164
- Tail Light ..... 163
- Lights, Indicator ..... 77
- Lights, Daytime Running ..... 165
- Lubrication Guide ..... 122-123

## M

- Main Key Switch ..... 67
- Maintenance Chart ..... 114-121
- Making Turns ..... 95
- Modifications ..... 15

## N

- No Passenger Warning ..... 39

## O

- Oil ..... 124
- Oil Change, Engine ..... 126-128
- Oil Change, Transmission ..... 131
- Oil Check, Engine ..... 125
- Oil Check, Transmission ..... 130
- Oil, Engine ..... 124
- Operation Warning ..... 35

## P

- Parking on a Hill or Incline ..... 105
- Passenger Warning ..... 39
- Periodic Maintenance Chart. 114-121
- Polaris Products ..... 182
- Polishing ..... 172
- Pre-Ride Inspection ..... 85-87
- Product Safety Commission ..... 14

## R

- Rack Warning ..... 40
- Riding Gear ..... 92-93

## S

- Safety Training ..... 7
- Seat Latch ..... 21
- Severe Use ..... 115
- Shift Lever ..... 20, 72
- Shock Spring Adjustment ..... 152
- Signal words ..... 8
- Spark Arrestor ..... 138-139
- Spark Plug Change ..... 133
- Spark Plugs ..... 132-133

### Specifications

- Outlaw 90 ..... 178-179
- Sportsman 90 ..... 180-181
- Speed Control System ..... 142-143
- Start Button ..... 69
- Starting the Engine ..... 88-90
- Steering Inspection ..... 152
- Stop Switch ..... 68
- Stopping the ATV ..... 24
- Stopping the Engine ..... 91
- Storage ..... 173-176

# Index

## S

### Switches

Engine Start Button . . . . .	69
Engine Stop Switch . . . . .	19, 68
Horn Button . . . . .	19
Ignition Switch . . . . .	23
Main Key Switch . . . . .	67
Tether Switch . . . . .	23

## T

Tail Light . . . . .	163
Tether Strap . . . . .	23
Throttle . . . . .	70
Throttle Cable Adjustment . . . . .	144
Throttle Control . . . . .	19
Throttle Lever . . . . .	71
Throttle Stop Speed Control System . . . . .	143
<b>Tire Pressure Warning</b>	
Outlaw 90 . . . . .	37
Sportsman 90 . . . . .	38
Tire Tread Depth . . . . .	160
Tires . . . . .	159
Toe Alignment . . . . .	150-151
Transmission Oil . . . . .	130-131
Transporting the ATV . . . . .	177
Turning Around on a Hill . . . . .	102-103

## V

Vehicle Identification Numbers . . . . .	66
Vehicle Immersion . . . . .	134-135

## W

Warranty . . . . .	196-197
Warranty, Emissions . . . . .	196-197
Washing the ATV . . . . .	170
Wheel Hub Tightening . . . . .	162
Wheel Installation . . . . .	161
Wheel Nuts . . . . .	162
Wheel Removal . . . . .	160