

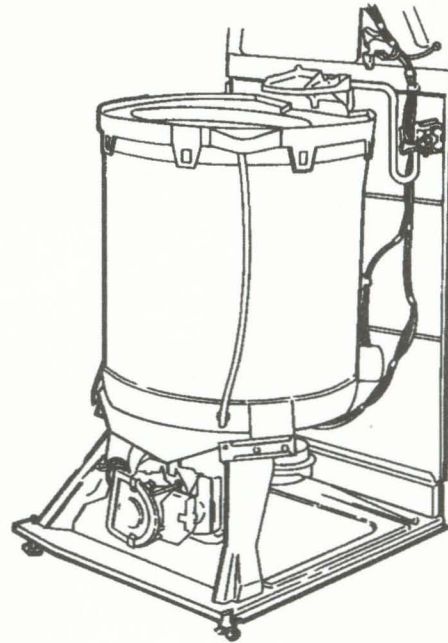

CONSUMER SERVICES TECHNICAL
EDUCATION GROUP PRESENTS

L-55

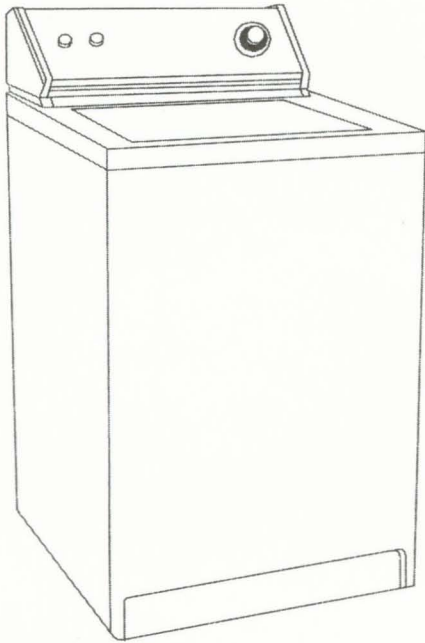

DIRECT DRIVE WASHERS

JOB AID
Part No. 787930 Rev. A

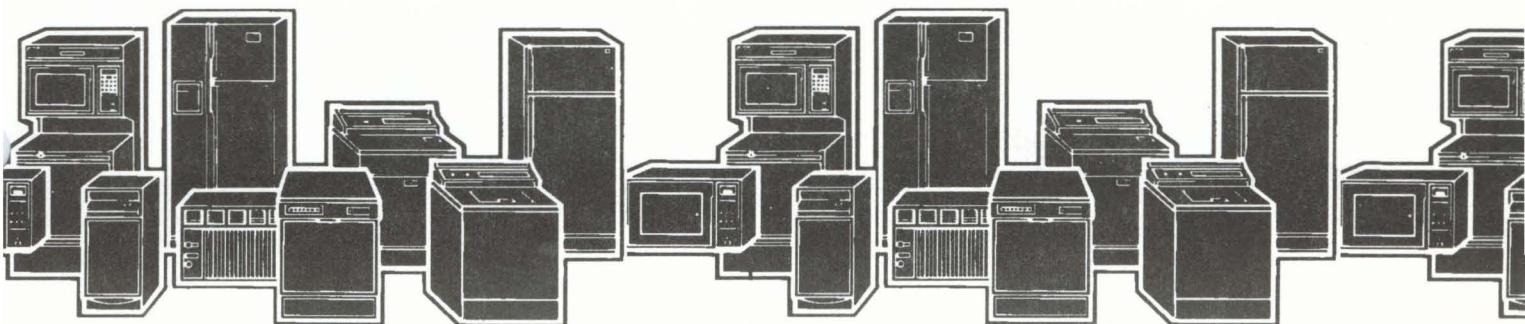

MODEL/SERIAL NUMBER DESIGNATIONS

The model number for the Whirlpool brand Direct Drive Washer contains the following designations:

Model Number	L	S	C	9	3	6	5	E	Q	0
Marketing Channel (if present)										
Product Group L = Laundry, Domestic G = Laundry, Gold										
L = Large Capacity A/W 27" P = 24" Compact A/W S = Super Capacity 27" A/W										
C = Clean Touch Console P = Push Button R = Rotary										
Cycles - Domestic (9) = 9 and 10										
A/W = Speeds Domestic										
Temperatures - Domestic										
A/W = Water levels										
Year of Introduction										
Color Q = White Z = Almond										
Engineering Changes (Numeric)										

The serial number for the Whirlpool brand Direct Drive Washer contains the following designations:

Serial Number	C	G	03	100003
Manufacture Location C = Clyde, Ohio				
Year of Manufacture				
Week of Manufacture				
Product Serial Number				

FOR TECHNICAL ASSISTANCE ON WHIRLPOOL DIRECT DRIVE WASHERS
WHILE AT THE CUSTOMER'S HOME CALL:

THE TECHNICAL ASSISTANCE LINE: 800-253-2870

Have your store number ready to identify you as an Authorized Servicer

INTRODUCTION

This Job Aid, *DIRECT DRIVE WASHERS*, (Part No. 787930 Rev. A), provides the technician with information on the installation, service and repair of Whirlpool-built Direct Drive Washers. This Job Aid is designed to assist in training and familiarization of the Whirlpool Direct Drive Washer System and replaces any previous version. For specific information on the model being serviced, refer to the Use and Care Guide or Tech Sheet provided with the washer.

The wiring diagrams and strip circuits used in this Job Aid are typical and should be used for training purposes only. Always use the wiring diagram on the product when servicing the unit.

This Job Aid can be used in conjunction with the video tape part no. 787929 Rev. A.

GOALS AND OBJECTIVES

The goal of this Job Aid is to provide detailed information that will enable the service technician to properly diagnose malfunctions and repair Direct Drive Washers.

The objectives of this Job Aid are to:

- Understand and follow proper safety precautions.
- Successfully troubleshoot and diagnose malfunctions.
- Successfully perform necessary repairs.
- Successfully return the washer to proper operational status.

TO THE INSTRUCTOR/INDEPENDENT STUDENT

At the end of certain sections of this Job Aid you will find a "Confirmation of Learning Exercise." A pencil will be necessary to complete these exercises. Certain exercises may require that service procedures be performed if an appropriate appliance is available.

This Job Aid is designed to be used with the video tape, *DIRECT DRIVE WASHERS*, (Part No. 787929 Rev. A). As you use this Job Aid, you will see a symbol that looks like this:



It instructs you to view certain section of the video tape. The section numbers will appear in the lower left corner of the television screen.



WHIRLPOOL CORPORATION ASSUMES NO RESPONSIBILITY
FOR ANY REPAIRS MADE ON OUR PRODUCTS BY ANYONE
OTHER THAN AUTHORIZED SERVICE TECHNICIANS.

TABLE OF CONTENTS

INTRODUCTION	Inside Front Cover
TABLE OF CONTENTS	III
SAFETY	IV
SECTION ONE	
INSTALLATION CONSIDERATIONS	1
SECTION TWO	
THEORY OF OPERATION	7
SECTION THREE	
COMPONENT ACCESS	19
Components in the Console	17
Components Inside the Washer Cabinet	22
SECTION FOUR	
DIAGNOSIS AND TROUBLESHOOTING	29
Diagnostic Chart	29
Component Testing.....	31
SECTION FIVE	
TECH TIPS	37
Wiring Diagram	37
Switch Cycle Chart	38
Model and Serial Number Designations ...	Inside Back Cover

SAFETY

YOUR SAFETY AND THE SAFETY OF OTHERS IS IMPORTANT

Safety messages have been provided in this manual where performing certain procedures may cause exposure to hazards that can kill or hurt you.



This is the safety alert symbol. All safety messages will be preceded by the safety alert symbol and the word "DANGER" or "WARNING".

These words mean:

 **DANGER**

**YOU WILL BE KILLED OR SERIOUSLY INJURED
IF YOU DON'T FOLLOW INSTRUCTIONS.**

 **WARNING**

**YOU CAN BE KILLED OR SERIOUSLY INJURED
IF YOU DON'T FOLLOW INSTRUCTIONS.**

All safety messages will identify the hazard, tell you how to reduce the chance of injury, and tell you what can happen if the instructions are not followed.

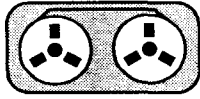

View Section One of the Video Tape

Section One INSTALLATION CONSIDERATIONS

UNPACKING THE WASHER

1. To unpack the washer, remove the carton top by carefully cutting around the top along the dotted line with a carton knife. (Fig. 1)
2. After removing the top, cut down the four corners and remove the washer.
3. Refer to the installation instructions taped to the washer's lid.
5. Remove the shipping strap as follows:
 - a. Carefully read, then remove the yellow label securing the power supply cord to the back of the washer. (Fig. 2)
 - b. Pull the yellow shipping strap completely out of the back of the washer. Be sure both cotter pins come out of the washer. Note that the power supply cord plug will still be attached to the yellow shipping strap. (Fig. 3)
 - c. Firmly pull on the end of the yellow shipping strap that is attached to the bottom of the back of the washer. (Fig. 4) This will release the self-leveling leg mechanism.

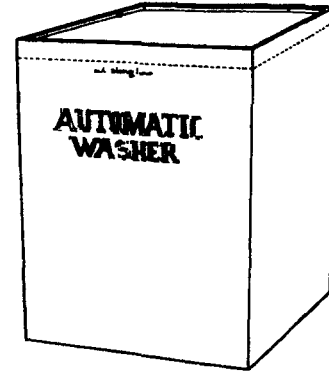

Fig. 1

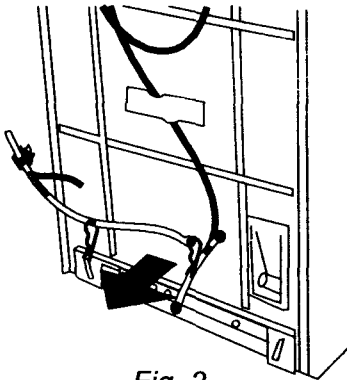

Fig. 2

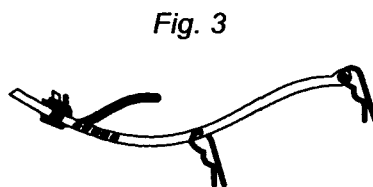

Fig. 3

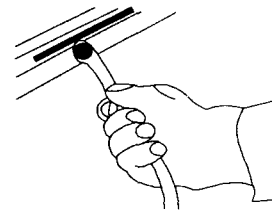

Fig. 4

NOTE: To prevent the two (2) shipping pins from falling on the floor, two (2) plastic holders are attached to the base. (Fig. 5) When the cotter pins are removed, the shipping pins fall into these holders. These pins may be left in the holder cups. (Fig. 5, INSET) They will not interfere with the operation of the washer.

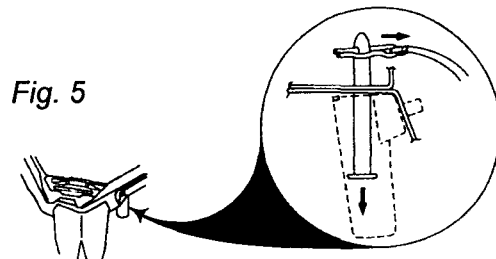

Fig. 5

6. Remove the items inside the washer basket.

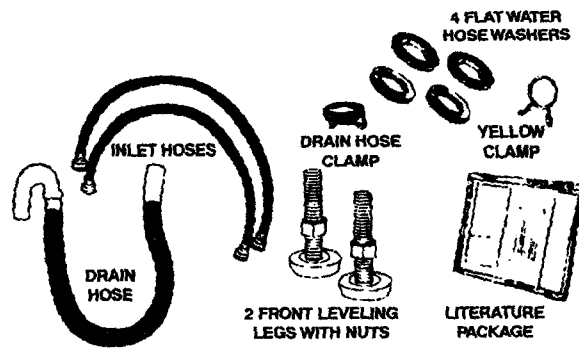

Fig. 6

7. Install a flat rubber washer into each end of the inlet hoses.

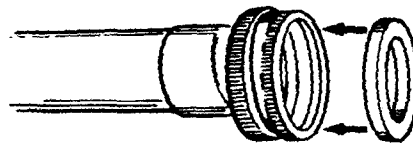

Fig. 7

8. Attach hoses to the water inlet valves. Attach the bottom inlet first. Be careful not to cross thread the inlet valves. Hand tighten and then tighten $\frac{1}{4}$ to $\frac{1}{2}$ turn with pliers.

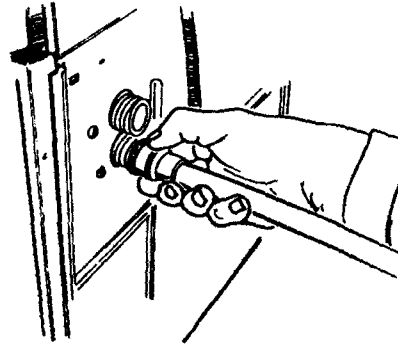

Fig. 8

9. Secure the hook end with the yellow hose clamp. (Fig. 9)

10. Push the other end of the drain hose down over the drain hose connector on the back of the washer all the way down to the ribbed stop. (Fig. 10) Secure with the clamp at the position shown in Figure 11.

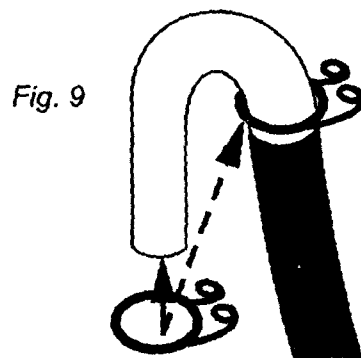

Fig. 9

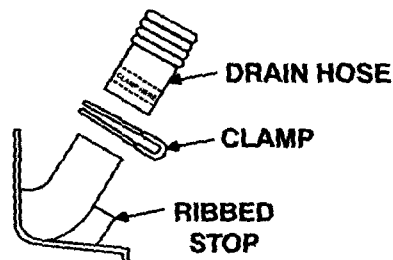

Fig. 10

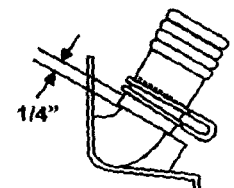

Fig. 11

10. Tilt the washer back and brace it with a piece of packing material.

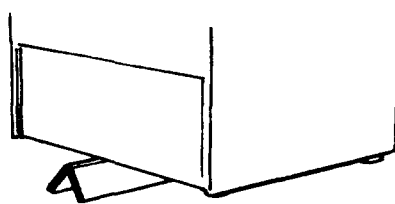

Fig. 12

11. Screw the lock nut down to within 1/2 inch of the base of the leg.

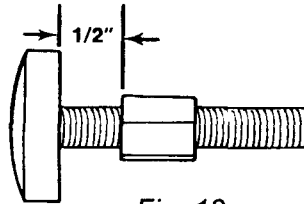

Fig. 13

12. Screw the legs into the holes at the front corners until the lock nuts touch the washer base.

13. Move the washer to its permanent location.

14. Tilt the washer forward off the floor and set back down to adjust the rear self-leveling legs.

15. Check the washer for level, both side-to-side and front-to-back. Adjust the front legs as necessary. Tighten the locking nuts to the base of the washer with a wrench. If the nuts are not tightened, the washer may vibrate excessively.

16. Run water through both faucets to get rid of particles in the water lines.

17. Attach the hoses to the water faucets. The bottom hose should be connected to the hot water supply and the top hose should be connected to the cold water supply.

18. Cut the shipping strap at the words "CUT HERE" and slide it off the power supply plug. (Fig. 14)

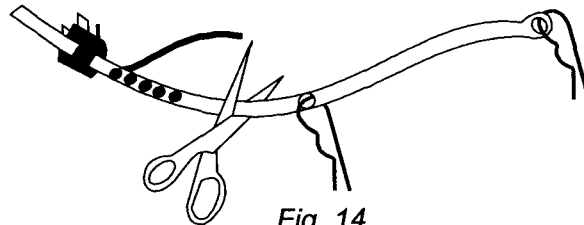

Fig. 14

19. The hook-end of the drain hose can be installed into a stand pipe (Fig. 15, A&B) or laundry tub, (Fig. 15, C) and secured with the shipping strap as shown.

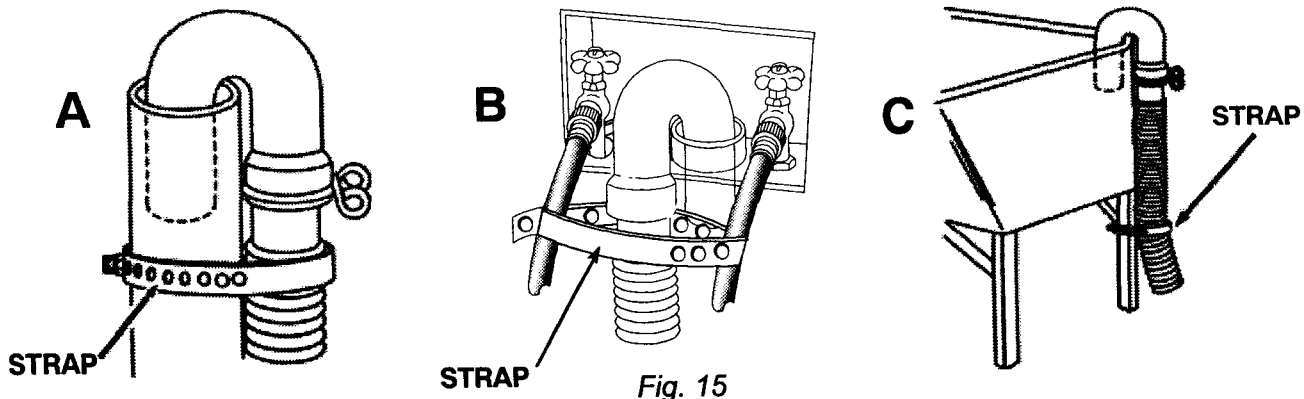

Fig. 15

NOTE:

Laundry Drain Requirements:

Laundry Tub or Utility Sink -

1. Laundry tub or utility sink should have a minimum capacity of 20 gallons.
2. Top of tub or sink must be a minimum of 34" and not more than 72" from the bottom of the washer.

Floor Drain -

1. Floor drain systems require a Siphon Break (Part No. 285320.) Siphon Break must be above the high water level in the washer tub (a minimum of 28" from the bottom of the washer.)
2. Additional drain hose will be required for a Floor Drain installation.

Standpipe Drain -

1. A minimum 2" diameter drain pipe with a minimum carry-away capacity of 17 gallons per minute is required.
2. Top of standpipe must be a minimum of 39" and not more than 72" from the bottom of the washer.

Electrical Requirements

! WARNING



ELECTRICAL SHOCK HAZARD

- Plug into a grounded 3-prong outlet.
- Do not remove ground prong.
- Do not use an adapter.
- Do not use an extension cord.

Failure to follow these instructions can result in death, fire or electrical shock.

GROUNDING INSTRUCTIONS

For your personal safety, this appliance must be grounded. This appliance is equipped with a power supply cord having a 3-prong grounding plug. (Fig. 16) To minimize possible shock hazard, the cord must be plugged into a mating 3-prong grounding type wall receptacle, grounded in accordance with the National Electrical Code, ANSI/NFPA 70-1987 or the latest code and local ordinances. If a mating wall receptacle is not available, it is the personal responsibility and obligation of the customer to have a properly grounded 3-prong wall receptacle installed by a qualified electrician.

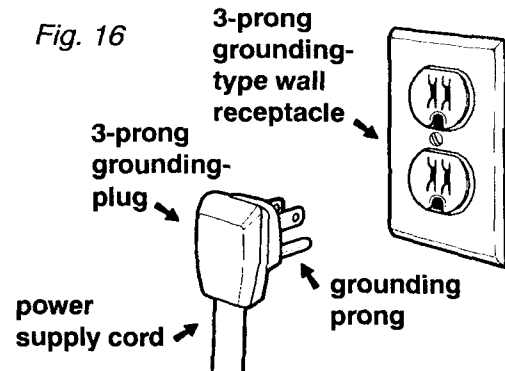

Observe all governing codes and ordinances. A 120 VAC, 15 or 20 amp fused electrical supply is required. (A time-delay fuse is recommended.) It is recommended that a separate circuit serving only this appliance be provided.

20. Plug in the washer.

21. Run a small load and check for leaks and proper operation.

COMMON INSTALLATION PROBLEMS

1. Water does not pump out.
Causes:
 - a. Drain hose too high (over six feet).
 - b. Blockage or crimp in the drain hose.
 - c. Drain pipe not vented.
2. Water on the floor.
Causes:
 - a. A leaking hose on the water inlet valve or faucet.
 - b. A leaking drain hose connection.
 - c. The drain hose is coming out of the stand pipe when draining.
 - d. Restricted drain pipe -- running beyond capacity.
3. The machine vibrates or "walks".
Causes:
 - a. Improperly installed front feet.
 - b. The washer is not level.
 - c. The shipping strap is not removed or a retaining pin is still attached to a shipping pin on the base of the washer.
 - d. Floor not solid.
 - e. Rear leveling legs not set.
4. The machine doesn't fill.
Causes:
 - a. The water faucets are not turned on.
 - b. There is a blockage in the hose or the fill valves.
 - c. Drain hose siphoning -- too low or siphon break not installed.

CONFIRMATION OF LEARNING EXERCISES

Unpack and install a Direct Drive Washer. Have an instructor or colleague who is knowledgeable on the Direct Drive Washer check your installation.

Section Two THEORY OF OPERATION FILL

1. The water level is selected by setting the switch at the desired level. This sets the tension on the diaphragm inside the water-level switch.
2. The water-level switch goes from the EMPTY position to the FULL position depending on how much tension there is on the diaphragm.
3. As the water level increases in the tub, it also causes an increase in air pressure in the air dome assembly. (Fig. 18) A hose between the air dome and the water-level switch transfers this pressure against the diaphragm in the water-level switch, causing electrical contacts (V to T) to close. This happens when the tub is FULL. (Fig. 19)
4. When the tub is drained to approximately half its original setting, the water-level will return back to the empty position (V to P).

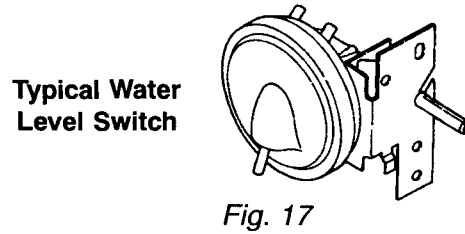

Fig. 17

**WATER LEVEL SWITCH
AT FULL POSITION**

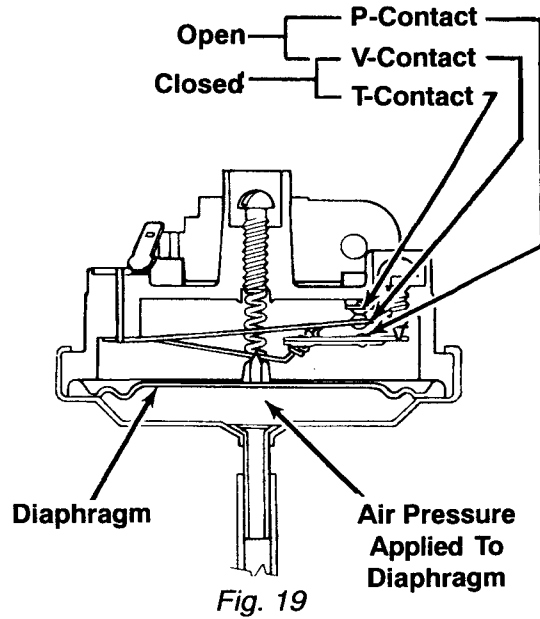

Fig. 19

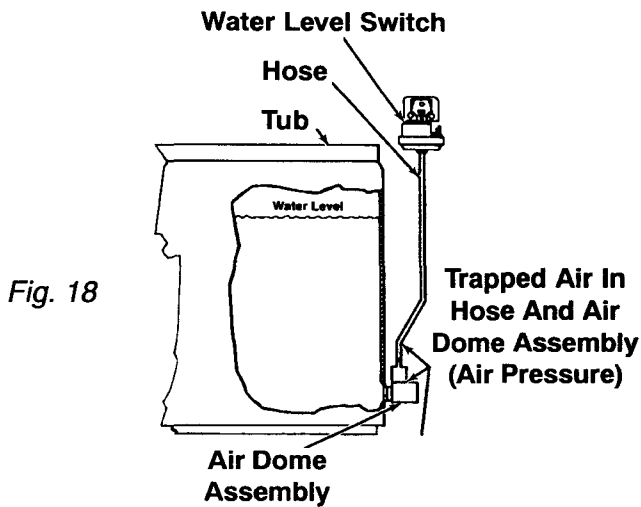

Fig. 18

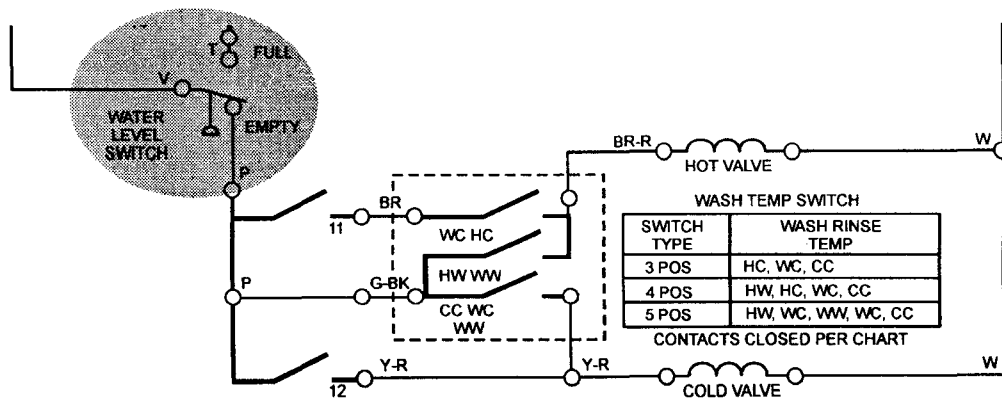

Fig. 20

5. The water temperature is selected by several switches that are set for mixing hot and cold water during the fill. Selecting a WARM wash with a COLD rinse closes these switches. (Fig. 21) The cycle sequence chart shows us that timer contact 11 is closed during the wash cycle. (Fig. 22)

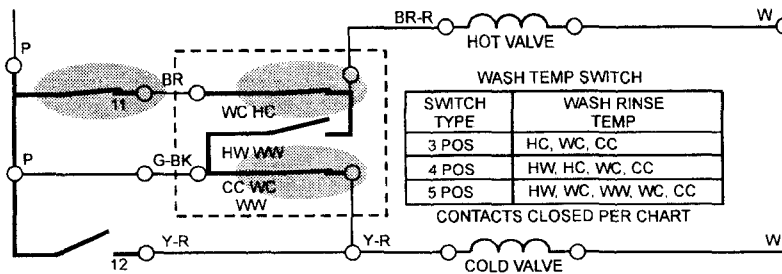

Fig. 21

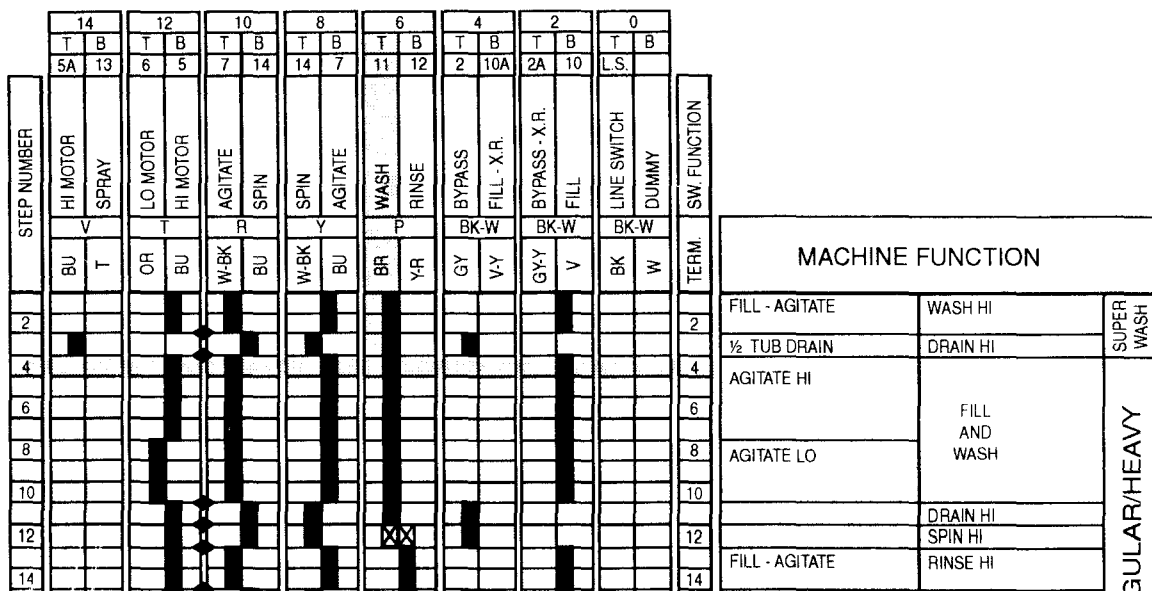

Fig. 22

6. To select the REGULAR cycle, push in the push/pull knob and turn the cycle selector to the REGULAR cycle. (Fig. 23)
7. According to the cycle sequence chart, the following contacts on the timer will be closed: Contact 10, Contact 5, both Contacts 7 and Contact 11.

When the push/pull knob is pulled out, the electrical current is supplied to the circuit. Since the tub is empty, V to P is closed on the water level switch. With a warm wash selected, the current is supplied to both the hot and cold valves to allow warm water to enter the tub. (Fig. 24)

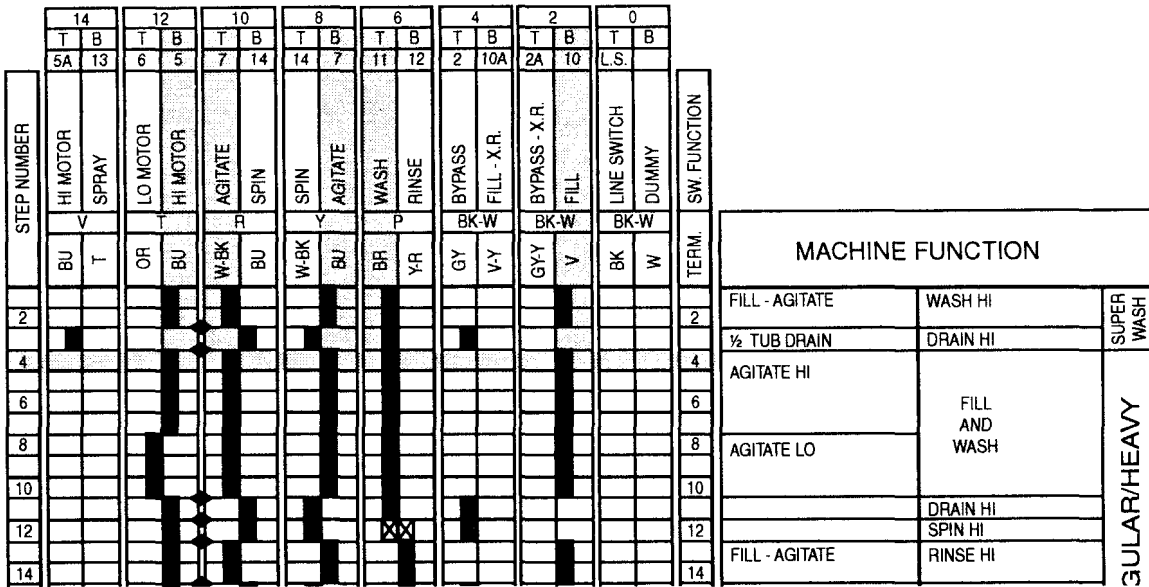

Fig. 23

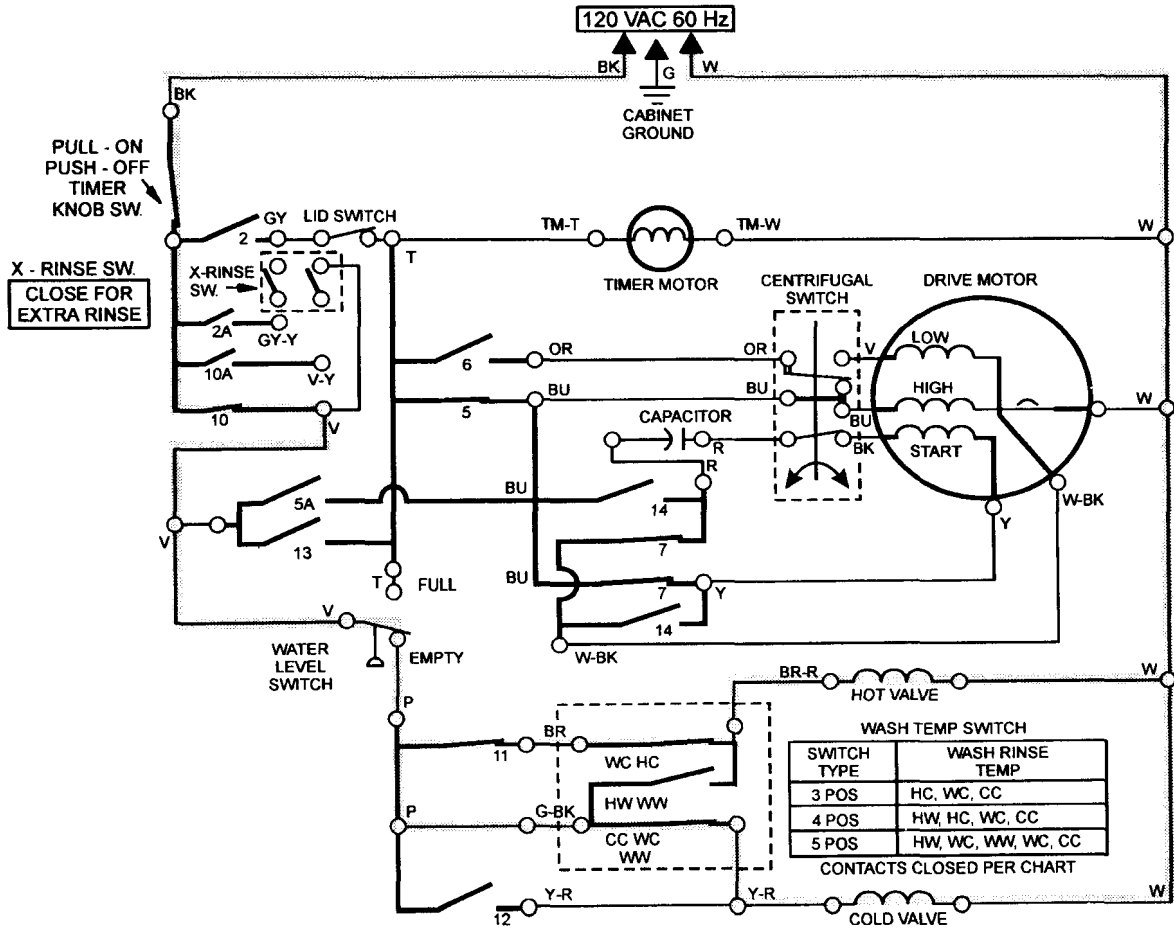

Fig. 24

AGITATE

1. Once the tub fills with water, the water level switch changes from the EMPTY position to the FULL position (V to T closes).

Current is removed from the fill valves and applied to the drive motor and the timer motor.

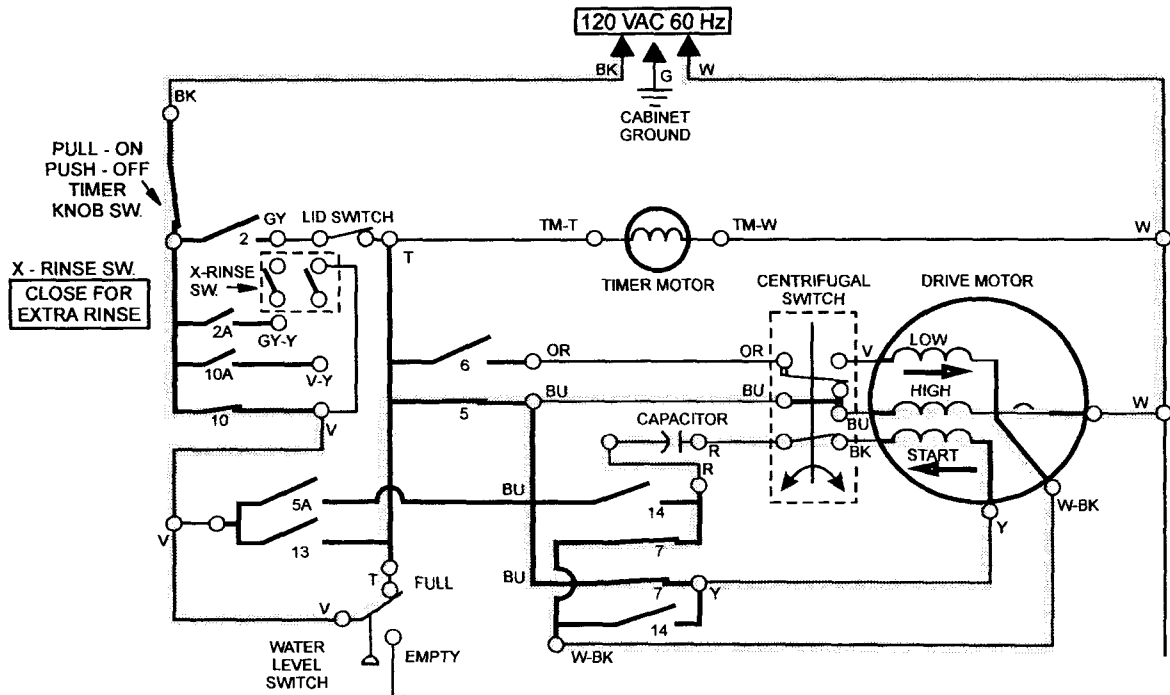

Fig. 25

2. Once there is power to the timer motor, the timer will start to advance. You can hear the sound of the drive motor running. The motor is coupled directly to the gearcase (Fig. 26) and will turn in the agitate direction. The direction of current through the start winding determines the direction of motor rotation. When contacts 7 are closed, the motor turns counterclockwise.

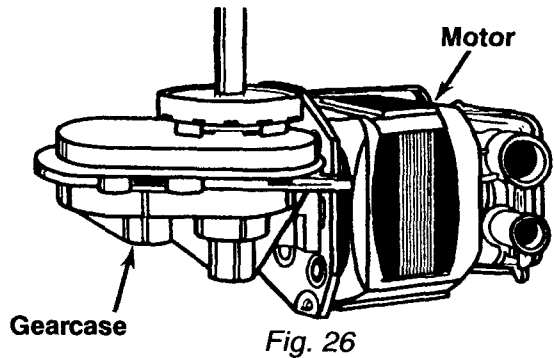

Fig. 26

3. When the motor turns counterclockwise, the main drive gear in the gearcase will turn clockwise, putting the washer into an agitation mode. (Fig. 27)

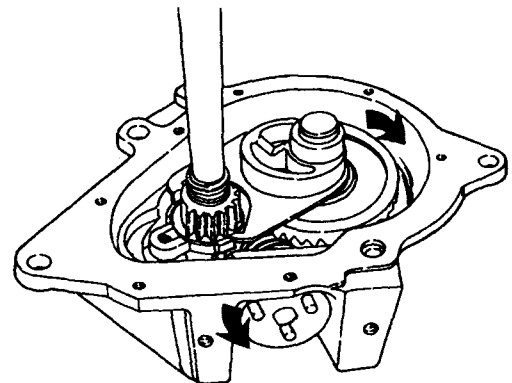

Fig. 27

- The main drive gear moves the shift actuator forward so that it engages the agitate cam (Fig. 28), and pushes it into the agitate position. (Fig. 29) The action of the agitate cam and cam follower allow the agitate gear to be forced down by spring action so that it engages the splines on the agitator shaft. (Figures 30 and 31) Now everything is set up for agitation.

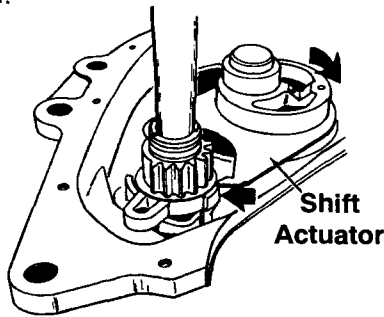

Fig. 28

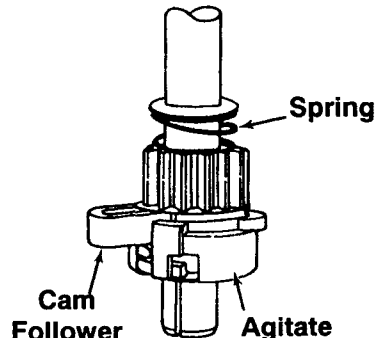

Fig. 29

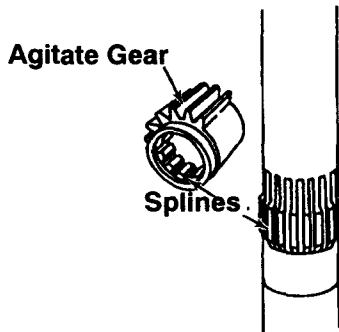

Fig. 30

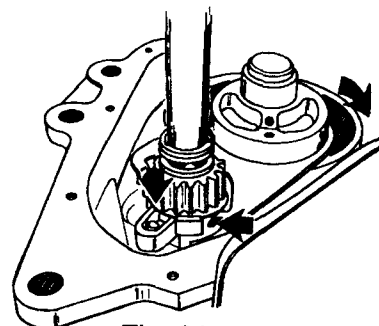

Fig. 31

- Power for the agitate gear is supplied by the connecting rack, which moves back and forth as it rotates around the cam on the main drive gear.

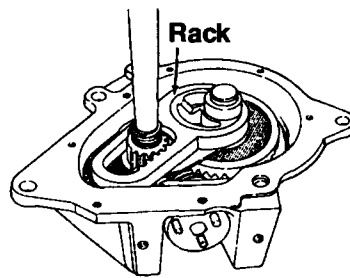

Fig. 32

- The pump is driven directly by the motor and runs whenever the drive motor runs. When the motor turns in the counterclockwise agitate direction, it drives the pump in the reverse direction, so water does not leave the tub.

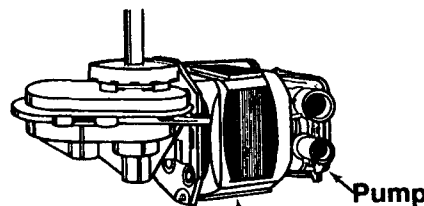

Fig. 33

7. The water is recirculated by the pumping vanes on the bottom of the agitator, which force the water up and through the lint filter at the bottom of the basket.
8. The timer cuts power to the drive motor after the timer motor runs for the length of wash time set on the cycle selector. The agitator shaft and the agitator stop moving back and forth and the wash function is completed.

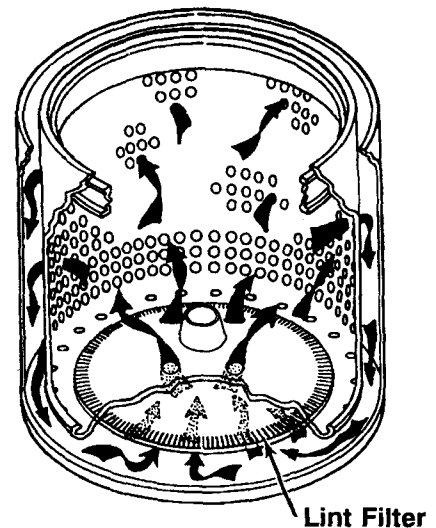

Fig. 34

SETTING THE NEUTRAL DRAIN

The neutral drain mechanism provides a pump-out prior to going into spin. The gearcase uses the following components.

- A. **Rack Retainer** - provides two locator pins and two (2) tabs for mounting neutral drain components.
- B. **Spin Pawl** - functions to drive the spin gear.
- C. **Spin Gear** - has a molded "button" added to one of three bosses. The button is required during the "Reset" mode of the neutral drain operation.
- D. **Spin Gear Cam** - a counting device to reset the neutral drain mechanism. The cam is mounted to the hub of the spin gear.
- E. **Trip Lever** - engages cam teeth. The molded button of the spin gear boss contacts the trip lever to lift it off the cam and advance it to the next cam tooth during the "Reset" mode of the neutral drain operation.
- F. **Latch** - holds the neutral mechanism stationary to allow for neutral drain pump-out prior to spin.

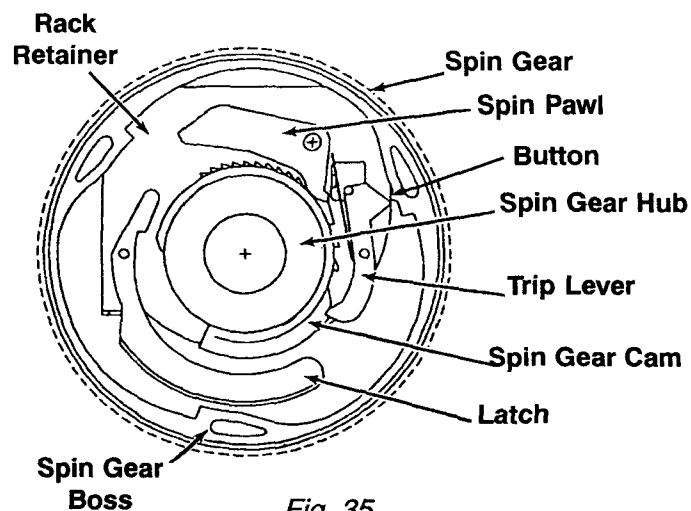

Fig. 35

Reset During Agitation

1. The gearcase will always provide direct-into-spin without draining first, except when reset during a brief three-to-five-second agitation period.
2. During agitation, the main drive gear and neutral drain mechanism rotate clockwise and the spin gear is idle.
3. The trip lever holds the cam at the cam teeth.
4. Each revolution of the main drive gear causes the trip lever to lift off a cam tooth as it contacts the button on the spin gear boss. The first ten revolutions of the main drive gear will cause the mechanism to reset for neutral drain.

DRAIN AND SPIN

1. Now the machine drains out the dirty water. The timer energizes the drive motor to run in the opposite direction, through contacts 2, 5, and both contacts 14. The motor now turns clockwise.

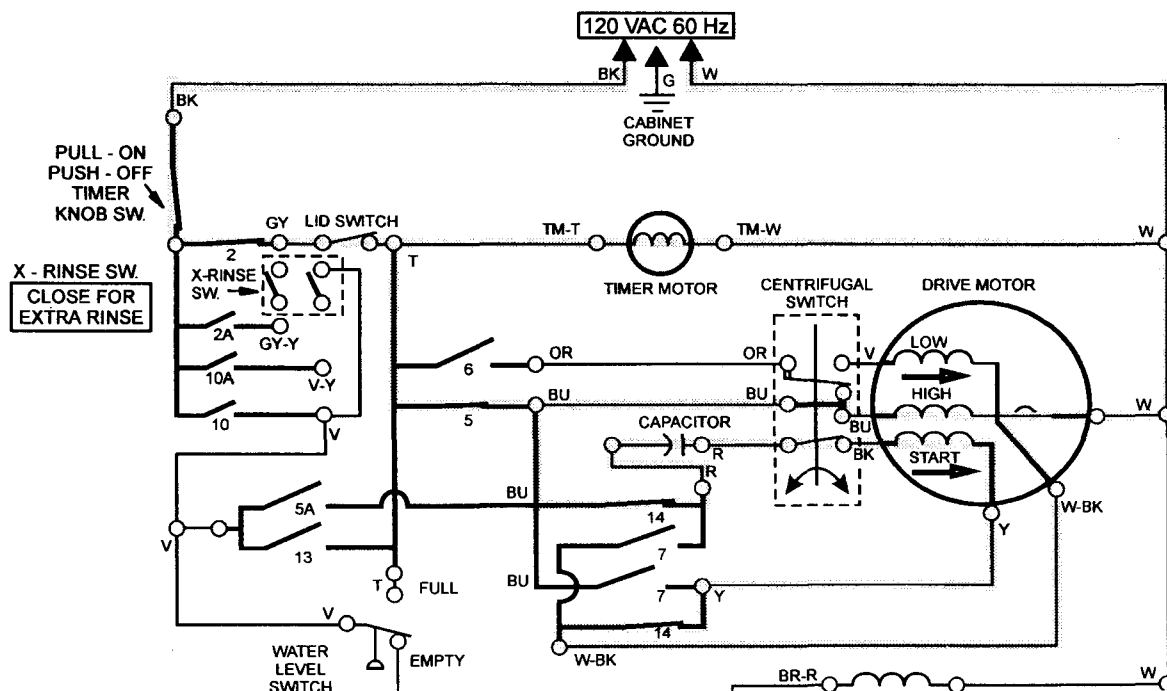

Fig. 36

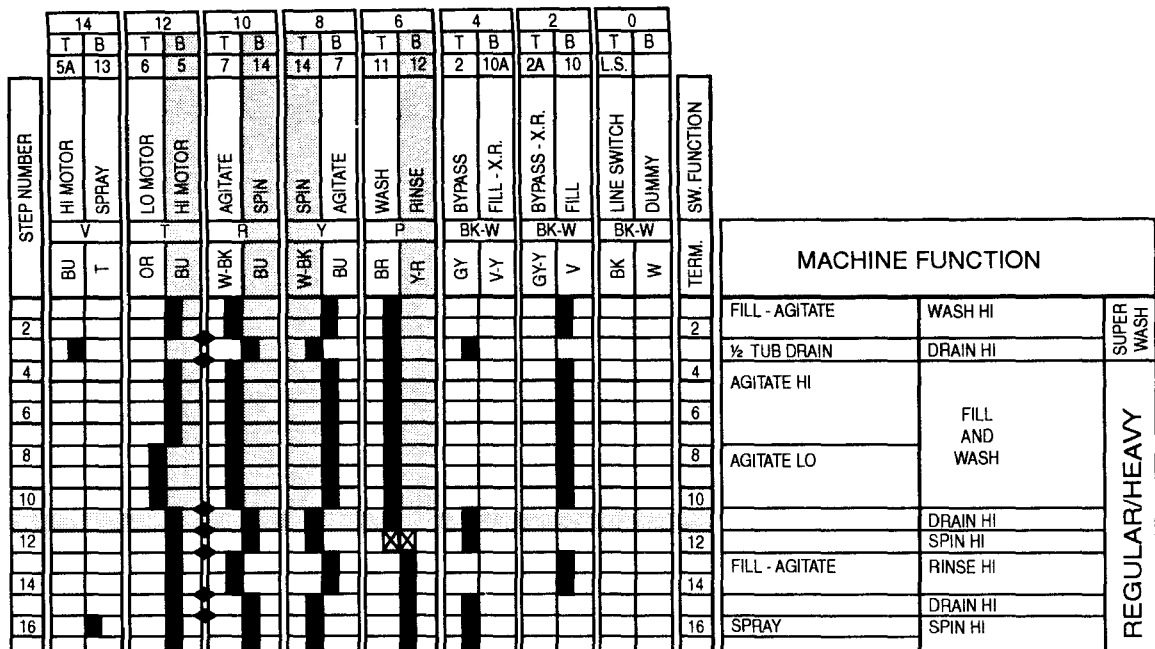

Fig. 37

- When the motor turns clockwise, the main drive gear in the gearcase will turn counterclockwise, putting the washer into the drain/spin mode. This time the shift actuator moves forward on the other side and pushes the agitate cam in the opposite direction. This causes the cam follower to push the agitate gear up and lift it off the splines on the agitator shaft. The main drive gear and neutral drain mechanism will rotate and the spin gear is idle.

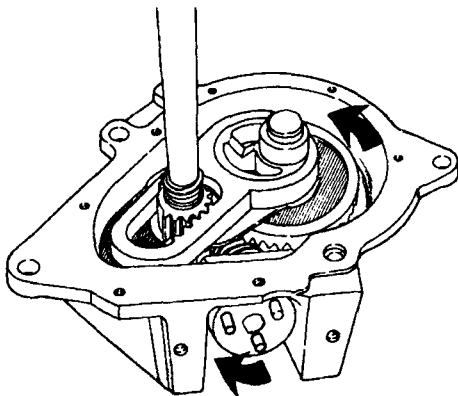

Fig. 38

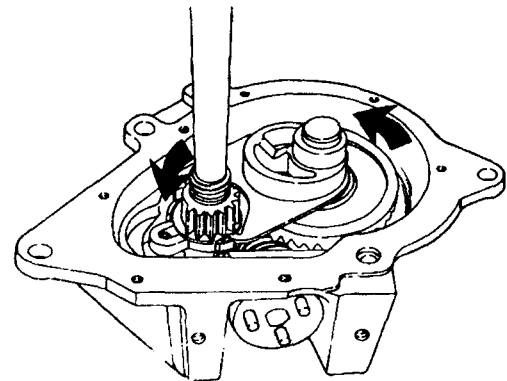

Fig. 39

- The latch stops the washer from going into spin. The latch is a weighted lever. The long end of it swings out when turning in the spin direction as a result of centrifugal force. This forces the short end inward where it can engage the spin gear cam and hold it in place. Now the spin gear cam slips on the hub and turns with the latch, the trip lever, and the pawl. The spin gear is stationary at this time.

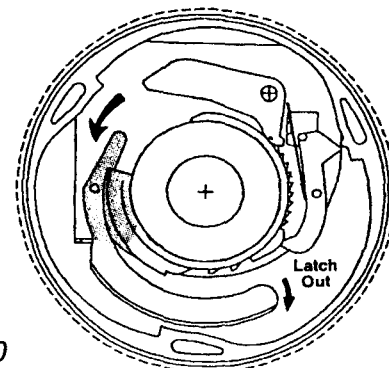

Fig. 40

- When the motor turns in the drain/spin direction, it turns the pump so that it pumps water out of the tub through the drain hose. This also brings the water down over the filter, flushing the lint off it and out the drain hose.

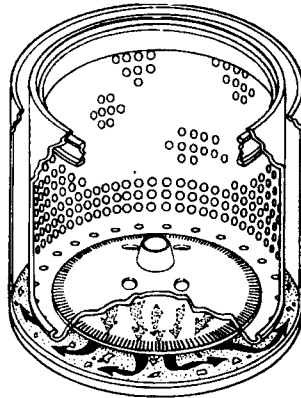

Fig. 41

- Because the bypass timer contact (2) is closed, the drive motor will continue to run even after the water-level switch returns to the empty position. This is necessary, because the water-level switch will trip when the tub is still approximately half full. A half-tub drain is used in the permanent press cycle to cool down the wash water to reduce wrinkling. A half-tub drain in the super wash cycle allows the washer to drain heavily soiled water and refill before going into the main wash cycle. Two minutes is more than long enough to drain the tub. After two minutes, the timer turns off the drive motor. You can hear it stop momentarily, before the timer advances to the SPIN function.

- Stopping the motor causes the latch to release the spin gear cam, allowing it to engage the spin pawl.

- The spin pawl will engage one of the three bosses on the spin gear, causing it to turn the spin tube and basket drive assembly in the spin direction. Because the clutch is attached to the spin pinion gear, the spin pinion gear turns, and the clutch hub also turns.

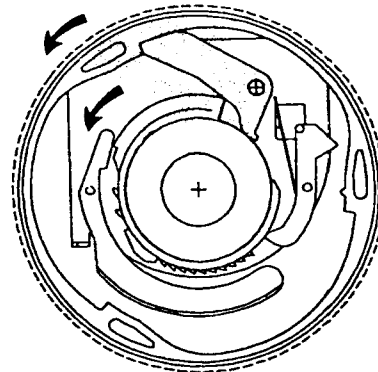

Fig. 42

- The clutch lining is forced against the clutch hub by the clutch spring. As the clutch hub turns, friction between it and the clutch lining causes the clutch lining to turn.

- As the clutch turns, the tab that holds the clutch spring on the lining contacts the brake cam driver, releasing the brake. The tab on the clutch lining stays in contact with the brake cam driver. The basket is attached to the spin tube with a drive block.

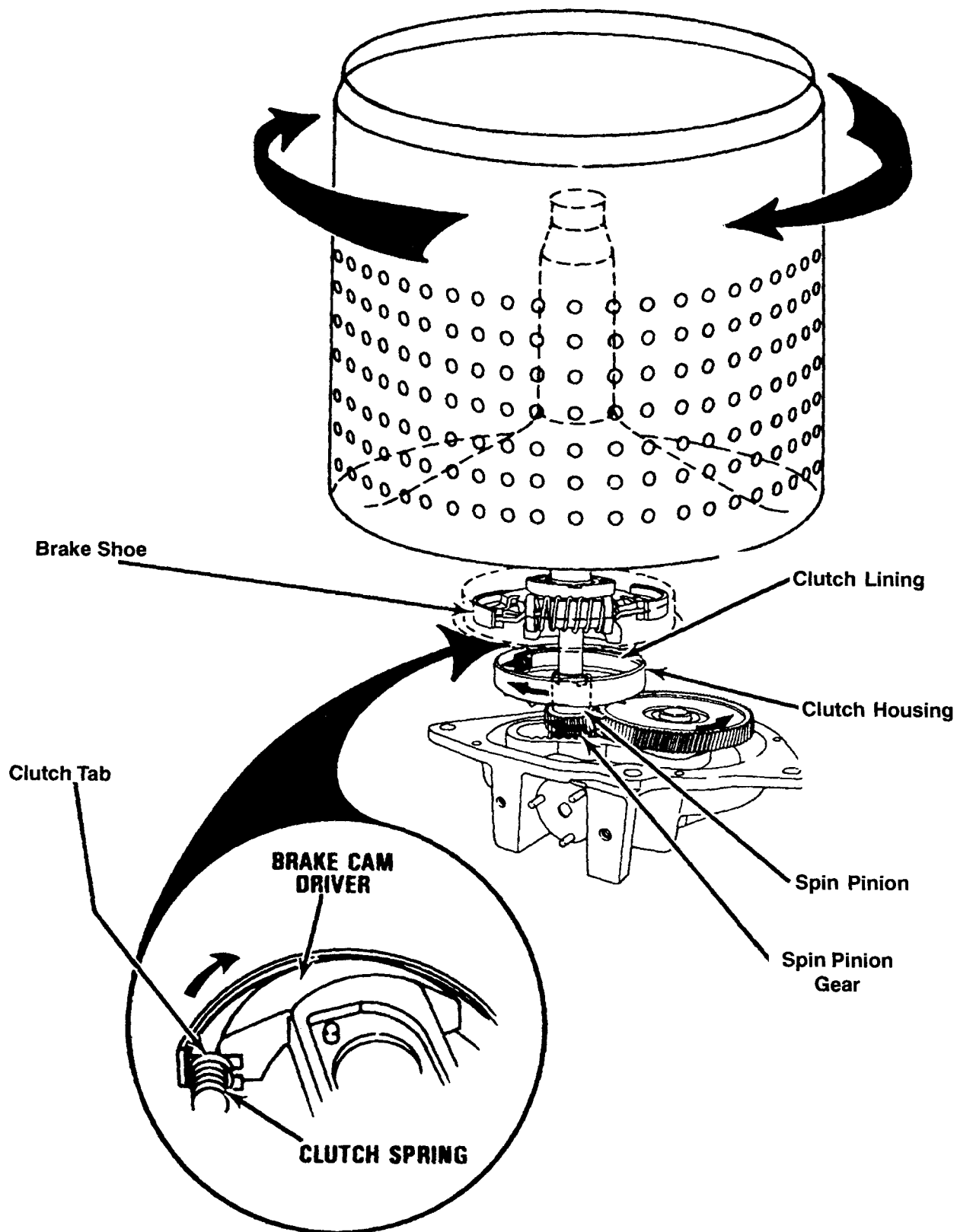

Fig. 43

CONFIRMATION OF LEARNING EXERCISES

1. Contact sets #7 and #14 perform what function?
2. Will the timer motor advance during a fill cycle?
3. What is the purpose of the "Neutral Drain" mechanism?
4. Why doesn't the water drain out during agitation?
5. In *Figure 22* (page 8), what contacts are closed for increment #8 (Agitate Lo)? What function did that change from increment #7?

When you are able to complete the above exercise, you may advance to the next section.

-- NOTES --

Section Three

COMPONENT ACCESS

COMPONENT LOCATION

! WARNING	
	ELECTRIC SHOCK HAZARD
	Disconnect the washer from the electrical power outlet before performing any service or repairs.
	Replace all panels before operating.
Failure to follow these instructions could result in death or electrical shock.	

ACCESSING COMPONENTS IN THE CONSOLE

A number of critical components can be accessed from inside the control console. These components are:

1. Timer
2. Push-button Switch Assembly
3. Water Level Switch

Servicing Components in the Console

1. Remove the two Phillips-head screws securing the front corners of the console to the washer top.
2. Tip the console back on the hinges that secure the top of the console to the washer back.
(Fig. 44)

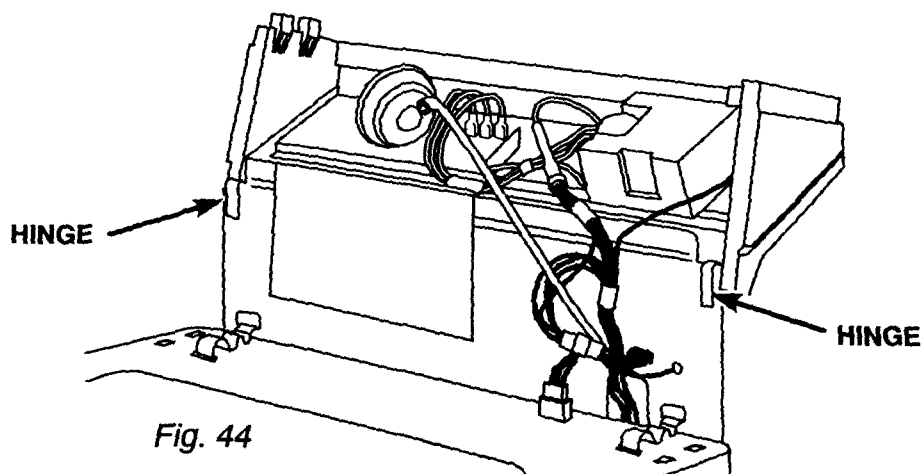

Removing the Timer

There are two types of timers. One can be identified by a plastic body. The other has a metal body.

Plastic Body

NOTE: DO NOT ATTEMPT TO REMOVE THE TIMER KNOB BY PULLING FROM THE FRONT. Doing so will damage the split shaft and require replacing the entire timer assembly.

1. To remove the timer knob, push the knob in from the front.
2. At the back of the timer, pull the black tab out approximately 3/16", then pull the timer knob off the shaft.

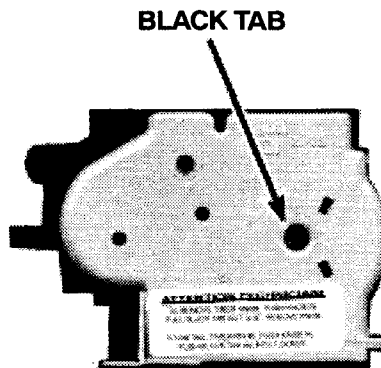

Fig. 45

3. Slide the timer dial from the timer hub.
4. Unplug the wiring harness connector from the timer assembly terminals.
5. Remove the one (1) Hex-head screw securing the left side of the timer assembly to the console mounting plate. Then lift the left side and slide the tabs at the right side of the timer assembly from the console mounting plate.

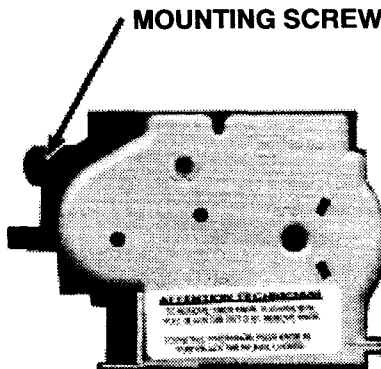

Fig. 46

Metal Body

1. To remove the timer knob, push the knob in from the front and unscrew it from the timer shaft. (Fig. 47)
2. Slide the timer dial from the timer hub.
3. Remove the two (2) Hex-head screws securing the timer assembly to the console mounting plate.
4. Unplug the wiring harness connector from the timer assembly terminals.

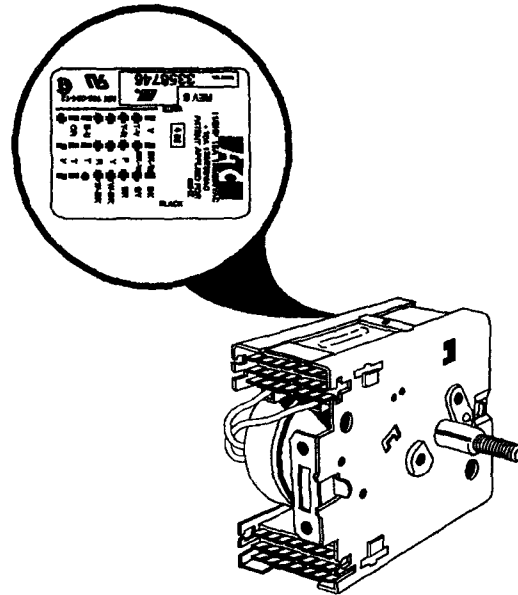
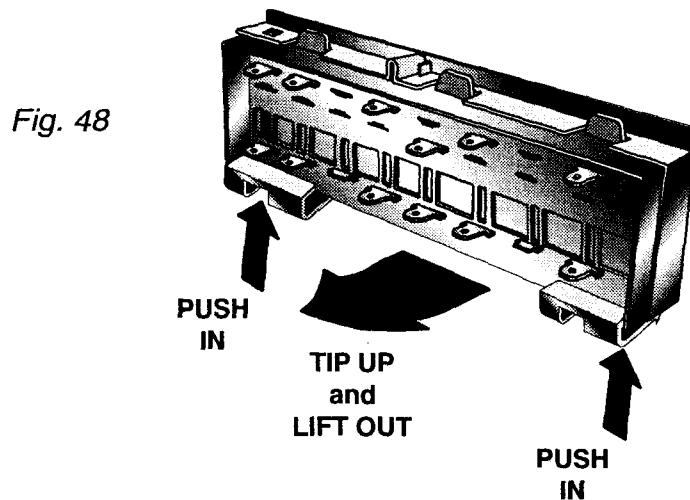

Fig. 47

Removing the Push-Button Assembly

1. Unplug the wiring harness connectors from the switch assembly terminals using a pair of needlenose pliers.
2. Press in the the two (2) tabs at the bottom of the switch assembly. Then, lift the bottom of the switch assembly up and lift it away from the console mounting plate. (Fig. 48)



Removing the Water Level Switch

1. Pull the knob off of the switch shaft.
2. Unplug the wiring harness connector from the switch assembly terminals and remove pressure switch tubing.
3. Remove the Hex-head screw securing the water level switch mounting bracket to the console mounting plate (Fig. 49-A) OR depress tab and rotate the switch 90° and pull it from the console mounting plate. (Fig. 49-B)

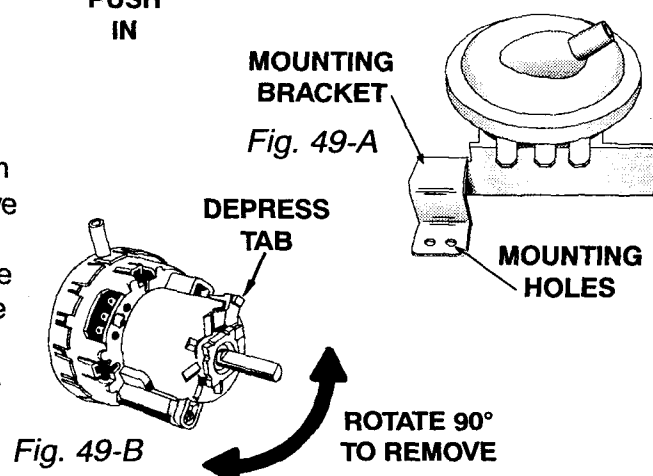

ACCESSING COMPONENTS INSIDE THE WASHER CABINET

Components inside the washer cabinet can be accessed by completely removing the outer cabinet as one unit. Refer to *Figure 50* for the following instructions.

1. Remove the console mounting screws and tilt the console into the service position.
2. Unplug the lid switch harness connector from the receptacle in the washer top.
3. Remove the cabinet mounting clips by placing the flat blade of a screwdriver in the clip as shown in *Figure 50, Inset 1*.

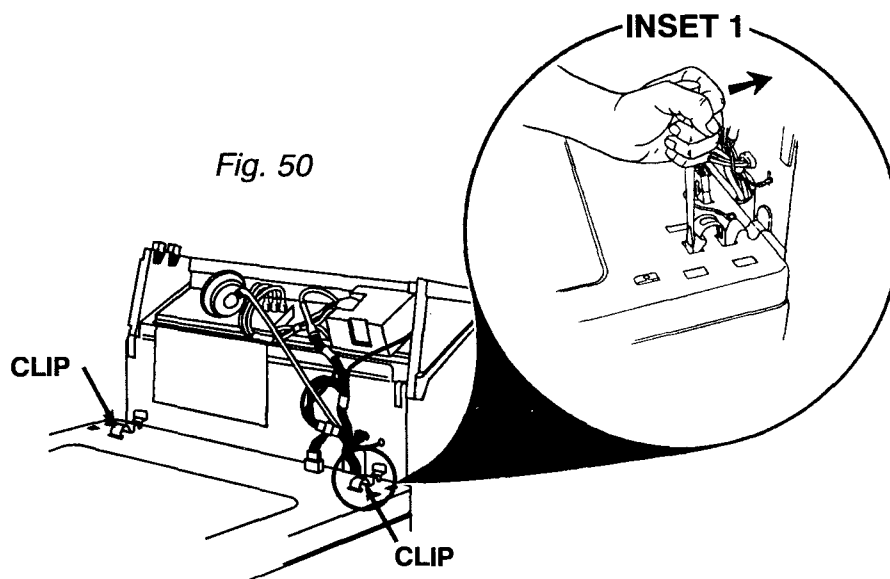

4. Remove the cabinet by tilting it forward and pulling it away from the washer. (*Fig. 51*)

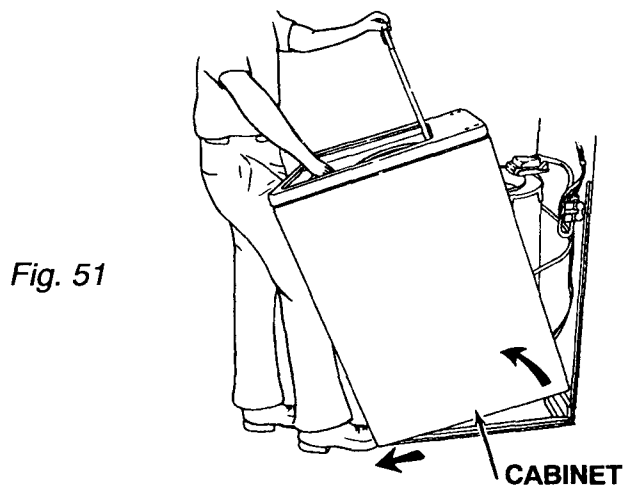

NOTE: If necessary, the washer can be operated in all cycles with the cabinet removed. Install a jumper wire in the lid switch harness connector as shown. (*Fig. 52*)

IMPORTANT: Use extreme caution when operating the washer with the cabinet removed.

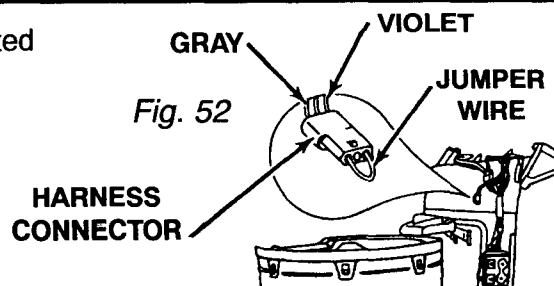

- The rear panel can be tilted back for additional access to components at rear of machine by twisting the rear panel support 90°, and then tilting the rear panel back. (Fig. 53)

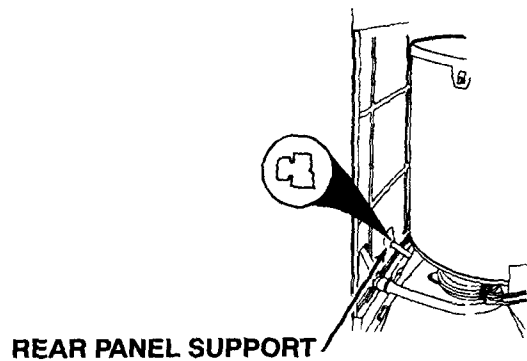

Fig. 53

REASSEMBLY NOTES

When reassembling the cabinet make sure the following steps are taken:

- When reinstalling the rear panel support, press in on the rear panel and rotate the support to lock the panel in position. (Fig. 54)
- The cabinet front flange must be under the washer base. (Fig. 55-A)
- Holes in the cabinet side flange must be placed over the tabs in the washer base. (Fig. 55-B)

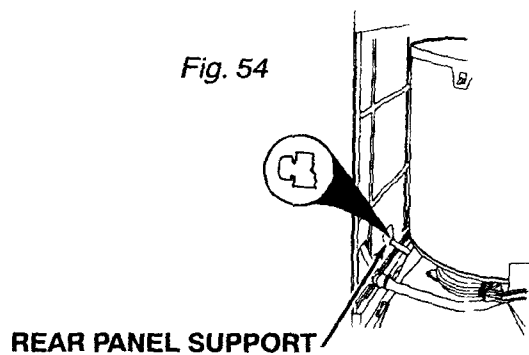

Fig. 54

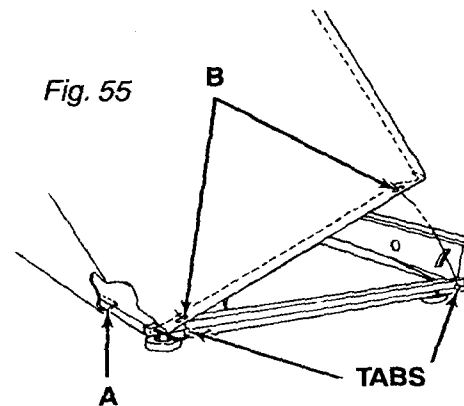
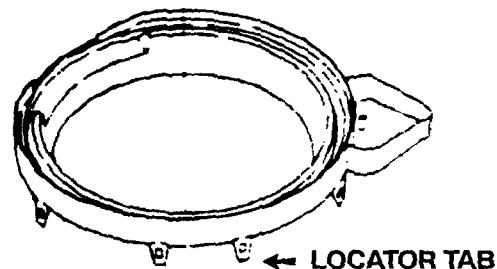

Fig. 55

SERVICING THE TUB AND BASKET

- To service the tub and basket, the cabinet must be removed.
- If it is necessary to remove the inner basket, begin by removing the tub ring by unsnapping the slots from the tabs on the tub. There are a total of eight tabs, one of which is a locator tab and which has a narrower slot than the others. (Fig. 56)

Fig. 56



3. The Surgilator Agitator is removed by first pulling off the agitator cap and inner cap. Then unscrew the 7/16" bolt found under the cap and pull straight up on the two-piece agitator assembly. The clutch and clutch dogs that provide the Surgilator action are found in the upper portion of the agitator assembly. (Fig. 57)

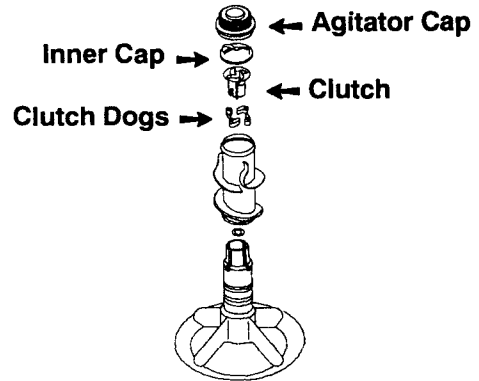

Fig. 57

4. Complete the removal of the basket by loosening the spanner nut on the spintube and expand the drive block with a wide bladed screw driver. (Fig. 58) The basket can now be lifted straight up and out of the tub.

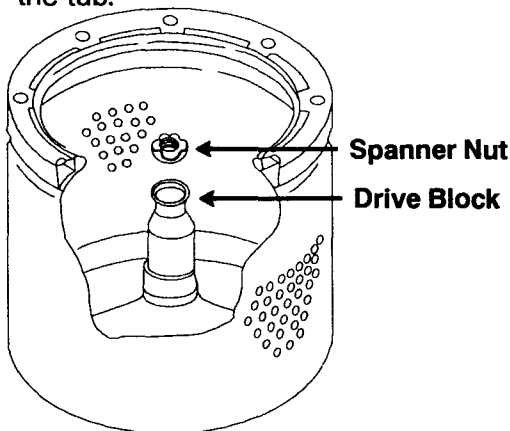

Fig. 58

4. The tub assembly is secured to the tub support at three locations. There are two screws, a suspension spring and a locating tab at each of these locations. (Fig. 59)

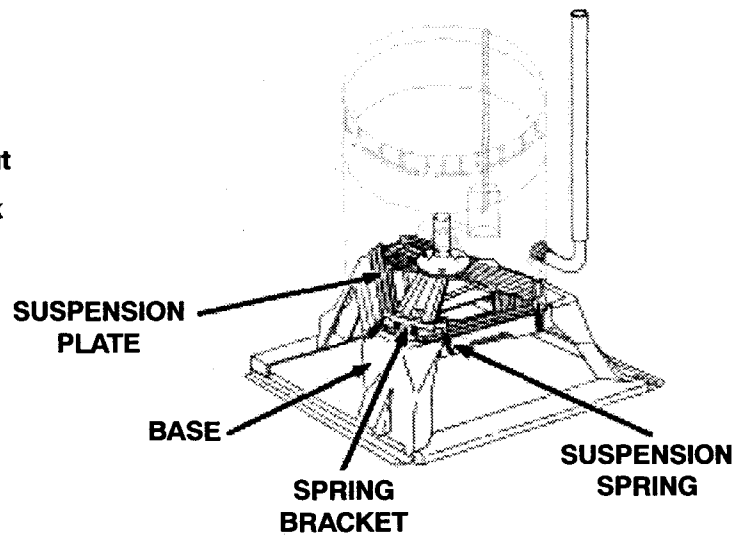
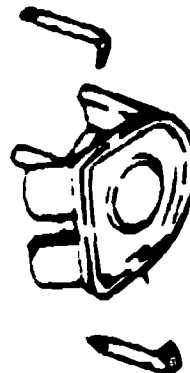

Fig. 59

SERVICING THE DRIVE MOTOR AND PUMP

The drive motor and pump can be accessed by removing the cabinet. The pump is a sealed unit and cannot be serviced. It should be replaced if it does not operate properly. The pump engages the drive motor directly and is held in place by two retainer clips. (Fig. 60)

Fig. 60



The motor of the Whirlpool Direct Drive Washer is a reversing type, running in one direction for agitation and in the other direction for drain and spin. The motor is held in place by two retaining clips and is coupled to the gearcase with two three-prong couplers and an isolation coupler. (Fig. 61)

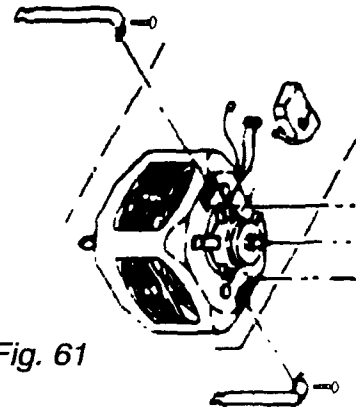

Fig. 61

In older models the motor start capacitor is located in the console. In newer models it is attached to the motor. Figure 62 is a typical capacitor.

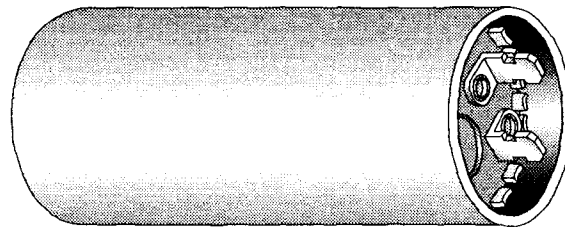

Fig. 62

SERVICING THE FRICTION PADS ON THE SUSPENSION PLATE AND BASE ASSEMBLY

The tub support and brake assembly are attached to the suspension plate, which rests on the base plate. This allows the tub and basket assembly to move in a gimbaling action.

The suspension plate and base assembly have friction resistance pads that provide protection between the metal assemblies.

1. Remove the outer cabinet from the washer.
2. Disconnect the wiring harness plug from the drive motor terminals.
3. Disconnect the tub outlet hose from the tub.
4. Remove the pump and motor.
5. Lift the entire tub, basket and tub support out as one unit.

The pads on the suspension plate are now accessible for replacement.

6. Lift the suspension plate from the base assembly.

The pads on the base assembly are now accessible for replacement.

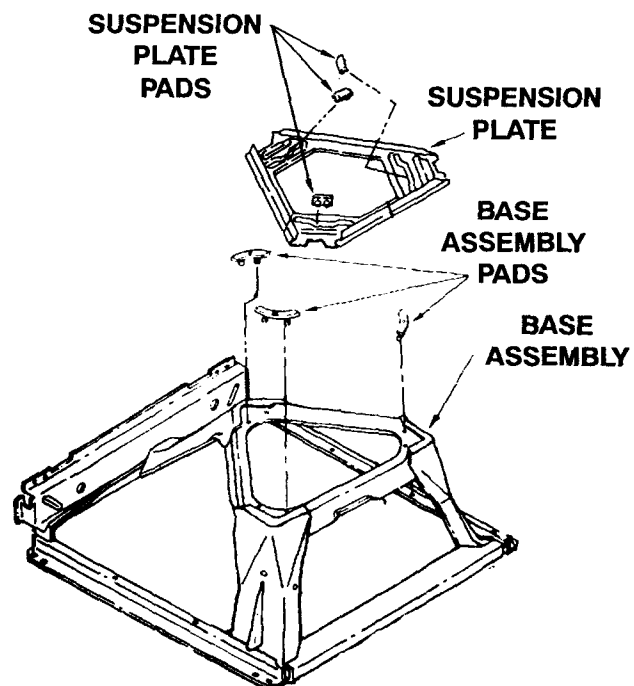
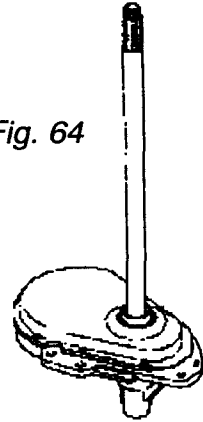

Fig. 63

SERVICING THE GEARCASE

1. Remove the outer cabinet.
2. Remove the agitator.
3. Remove the pump and motor assemblies.
4. Carefully lay the washer on its back.
5. Remove the three (3) bolts securing the gearcase assembly to the tub support.
6. Pull the gearcase straight out from the tube support assembly. (Fig. 64)

Fig. 64



Servicing the Clutch

1. Remove the gearcase.
2. To service just the clutch lining, compress the clutch spring with a pair of pliers and lift the lining from the clutch hub. (Fig. 65)

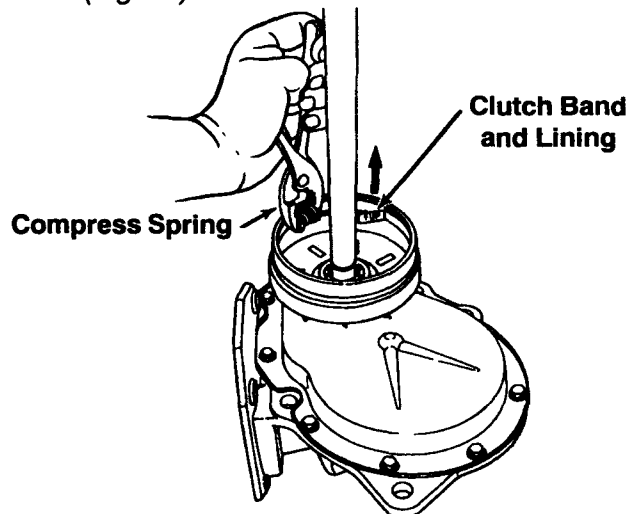

Fig. 65

3. To remove the entire clutch assembly, begin by removing the spin tube thrust washer up and off the agitator shaft and then remove the tube support ring. (Fig. 66)

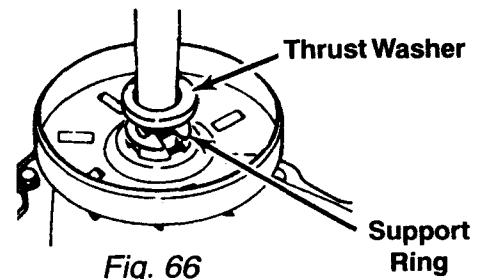

Fig. 66

4. Remove the retainer ring and lift the clutch hub up and off the spin pinion. (Fig. 67)

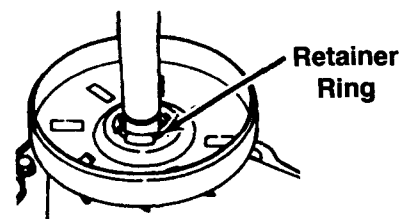

Fig. 67

Removing the Brake and Drive Assembly

1. Remove the outer cabinet.
2. Remove the agitator.
3. Remove the tub ring and basket.
4. Remove the pump and motor assemblies.
5. Carefully lay the washer on its back.
6. Remove the three (3) bolts securing the gearcase assembly to the tub support.
7. Pull the gearcase straight out from the tube support assembly.
8. Rotate the brake cam driver counterclockwise to release the brake. Pull the brake and drive tube straight out. (*Fig. 68*)

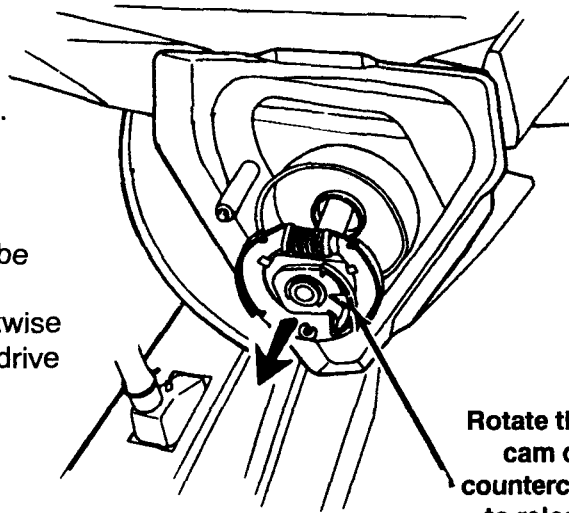

Fig. 68

Rotate the brake cam driver counterclockwise to release the brake. Pull the brake and drive tube straight out.

CONFIRMATION OF LEARNING EXERCISES

If a washer is available, perform the following service access procedures.

1. Remove the outer cabinet.
2. Remove the basket and tub assemblies.
3. Remove the pump and drive motor assemblies.
4. Remove the gearcase from the tub support.
5. Remove the brake and drive tube assembly.
6. Remove the suspension plate.
7. Reassemble and test unit.



View Section Four of the Video Tape

Section Four

DIAGNOSIS AND TROUBLESHOOTING

PROBLEM	POSSIBLE CAUSE	ACTION
1. MOTOR WILL NOT RUN NOTE: In diagnosing this problem, start the washer. If the motor runs in either agitate or drain, the motor is OK.	No/low voltage to machine	Check supply voltage (100-130 volts)
	Thermal overload tripped	Check Overload
	Timer switches	Check continuity
	Poor connection on timer	Secure terminal
	Motor centrifugal switch	Check continuity
	Motor disconnect block loose	Secure disconnect block
	Motor	Check windings
	Wiring harness	Check continuity
	Incorrect harness wiring	Check harness connections
	Water level switch	Check continuity
	Pump jammed	Replace pump
	Gearcase jammed	Replace gearcase
	Lid open in spin cycle	Close lid
2. NO AGITATE OR SPIN BUT MOTOR RUNS	Broken motor coupler	Replace coupler
	Internal gearcase problem	Replace gearcase
3. WATER WILL NOT ENTER MACHINE.	Water turned off at supply	Check faucet - turn on
	No/low voltage to machine	Check supply voltage (100-130 volts)
	Water temperature switch	Check continuity
	Timer switches	Check continuity
	Wiring harness.	Check continuity of wiring
	Poor connection at water inlet valve solenoid	Secure terminal
	Water level switch	Check continuity
	Incorrect harness wiring	Check harness connections
	Water level switch out of calibration	Replace switch
4. WATER LEVEL TOO LOW.	Customer misunderstanding of correct water level	Check water level per specification sheet
5. MACHINE WILL NOT AGITATE.	Wiring harness	Check continuity
	Motor	See problem 1
	Stripped agitator spline	Replace agitator
	Damaged agitate cam	Replace gearcase
	Damaged agitate gear	Replace gearcase
	Broken agitator shaft	Replace gearcase
6. INTERMITTENT AGITATE.	Pause in timer	Normal condition
	Damaged agitate cam	Replace gearcase
	Agitate gear clutch teeth worn or broken	Replace gearcase

PROBLEM	POSSIBLE CAUSE	ACTION
7. KNOCK DURING AGITATE.	Agitator splines	Replace agitator
	Excessive clearance on pinion thrust or main drive gear	Replace gearcase
8. TRIES TO AGITATE DURING SPIN.	Shift actuator or cam damaged	Replace gearcase
9. WATER DOES NOT DRAIN FROM MACHINE.	Clogged drain	Remove obstruction
	Pump	Replace pump
	Drain hose kinked	Relocate hose to prevent kink
10. SLOW OR NO SPIN. NOTE: In diagnosing this problem, start the washer in spin and see if the clutch drum spins. If it spins, the problem is <i>not inside the gearcase</i> . If the clutch drum does not spin, all or some of the problem is inside the gearcase.	Lid open	Close lid
	Lid switch defective	Check continuity
	Lid switch disconnect plug open	Check plug engagement
	Wiring harness	Check continuity
	Timer switches	Check continuity
	Motor	See problem 1
	Cam driver broken	Replace driver
	Weak clutch spring	Replace spring
	Spin tube	Check bearings and replace
	Clothes between basket and tub	Remove
	Worn Clutch Lining	Replace clutch
11. MACHINE WILL NOT SPRAY RINSE.	Water inlet valve	Check voltage
	Water temp. switch (if used)	Check continuity
	Timer switches	Check continuity
	Wiring harness	Check continuity
12. EXCESSIVE VIBRATION OR MACHINE WALKS.	Not level	Level
	Front leveling leg locknuts not tight	Secure locknut against frame after leveling
	Weak floor	Advise customer
	Unbalanced load	Redistribute load
	Shipping pins not removed	Remove pins
	Rear leveling legs stuck	Loosen
	Rear Cabinet sides loose	Remove top clips, push cabinet sides inward when reinstalling top clips
	Suspension plate sticky	Replace plate
	Suspension plate damaged or worn	Replace plate
	Suspension pads damaged or worn	Replace pads
	Tub support friction area sticky	Replace tub support
	Tub support damaged or worn	Replace tub support
	Suspension springs missing Broken or not connected	Replace or reconnect springs
	Basket ballast missing	Replace basket balance ring
Base bent/out of square	Replace base	

PROBLEM	POSSIBLE CAUSE	ACTION
13. CLOTHING DAMAGE	Excessive use of bleach	Instruct customer
	Overloading of machine	Instruct customer
	Foreign objects	Remove
	Water level too low	Increase water level
	Agitates during spin	See problem 8
	Agitator	Replace agitator
	Basket	Replace basket
14. GEARCASE LEAKS OIL	Leak at agitator shaft	Replace seal
	Leak at cover seal	Reseal
	Too much oil in gearcase	Use only 13-15 ounces in gearcase
	Defective cover	Replace cover
15. WATER LEAKS	Use of low water level with high agitation	Advise customer to use higher water level
	Leaking components	Repair or replace
16. BRAKE SQUEAL	Contaminated linings	Replace brake shoe assembly

COMPONENT TESTING

NOTE: Refer to the wiring diagram for the specific model being serviced. The wiring diagram can be found behind the console on the feature panel.

WATER INLET VALVE

To test the water inlet valve, remove the wiring harness connectors from each solenoid.

Set the meter on the R X 100 scale and attach the meter probes to the terminals on each solenoid. The meter should show between 200 and 900 ohms resistance.

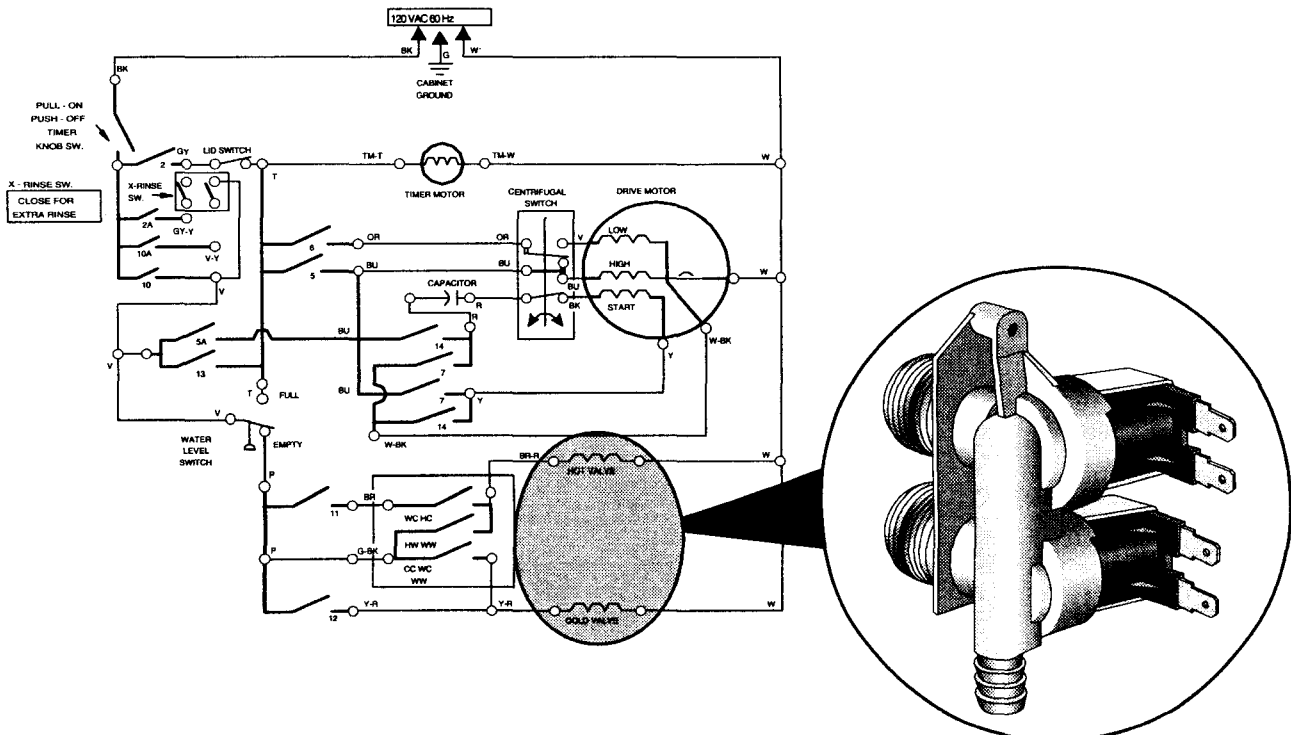

CENTRIFUGAL SWITCH

To test the centrifugal switch, remove the pump and disconnect the motor harness block from the centrifugal switch.

Remove the switch from the motor, and remove the internal motor wires from the centrifugal switch.

Set the meter on the R X 1 scale and test the switch in the “start” position by pushing up on the switch actuator. Continuity should be present between the red and black terminals and between the orange and blue terminals. No continuity should be present between orange and violet.

Test the switch in the “run” position by releasing the actuator. Between the orange and violet terminal, continuity should be present. Between the red and black terminals no continuity should be present.

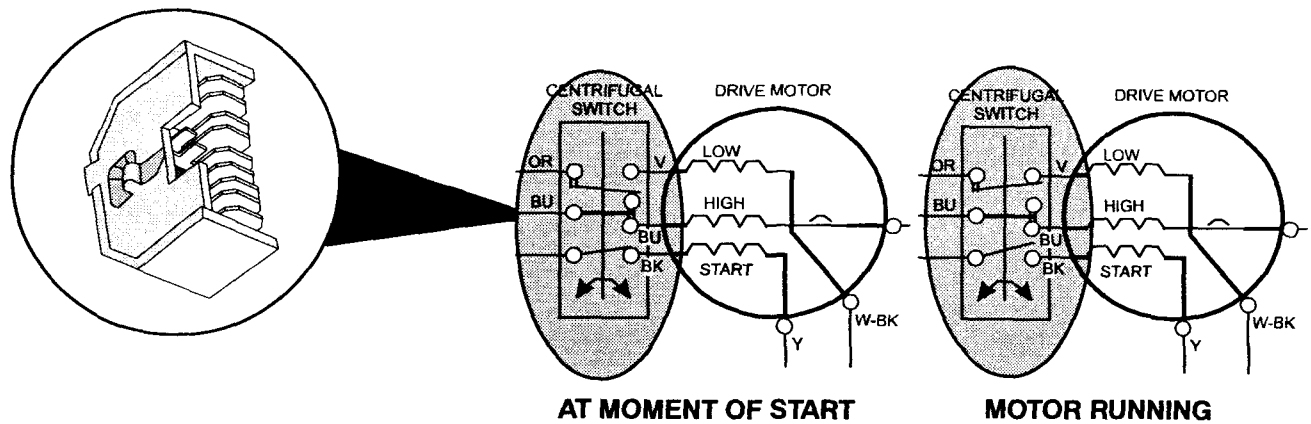

DRIVE MOTOR

To check out the motor, first remove the motor harness from the centrifugal switch. Then, set the meter on the R X 1 scale and check the start winding for continuity by testing between the black and yellow wires. A resistance reading between four and seven ohms should be present.

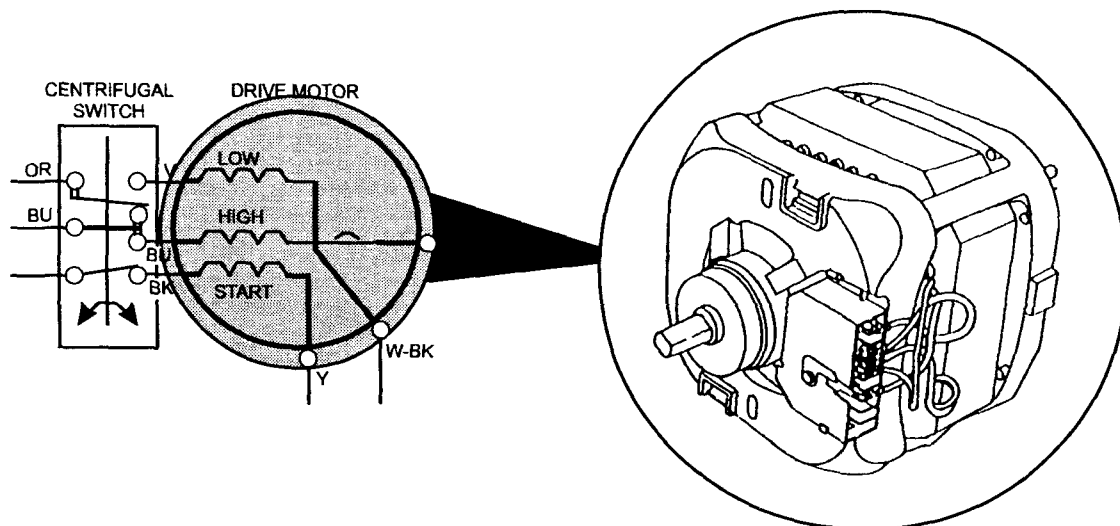

Check the high-speed windings by testing between the blue and white wires. A resistance reading between 3/4 ohm and 2 ohms should be present.

Check the low-speed winding by testing between the violet and the white wire. A resistance reading between 1 1/2 and 3 ohms should be present.

Check between the white and white-black wires. There should be 0 ohms resistance.

START CAPACITOR

To test the start capacitor, remove the wires from the capacitor leads.

Discharge the capacitor using an insulated screwdriver.

With the meter on the R X 100 scale, place the meter leads on the capacitor leads.

The meter needle should deflect toward "0" and then reverse toward infinite resistance if the capacitor is good.

If there is no needle deflection, the capacitor is "open".

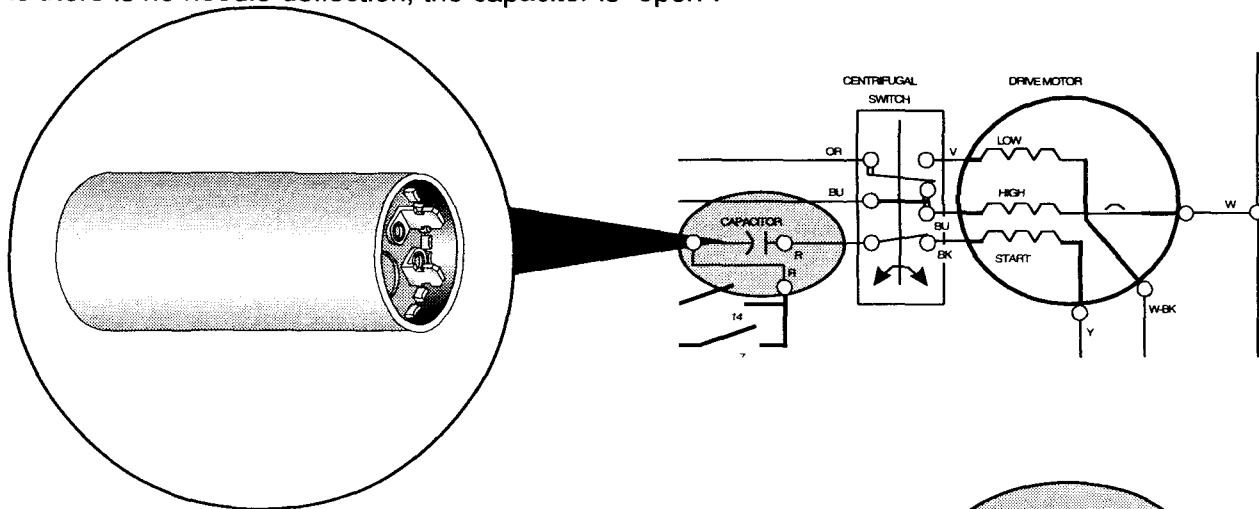

WATER TEMPERATURE SWITCH

To test the water temperature switch, set the water temperature switch to warm wash/cold rinse.

Remove the brown-red wire and the yellow-red wire from the switch.

Test between the brown-red terminal and brown terminal for continuity.

Test between the green-black and yellow-red terminals for continuity.

Set the water temperature switch to hot wash/warm rinse.

Test between green-black and brown-red continuity.

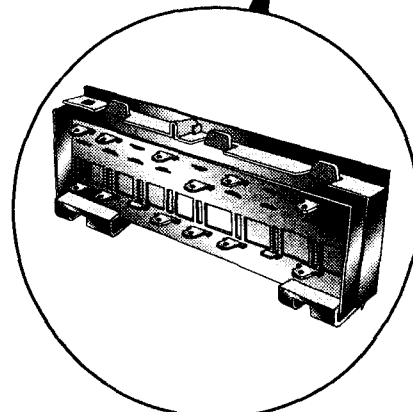
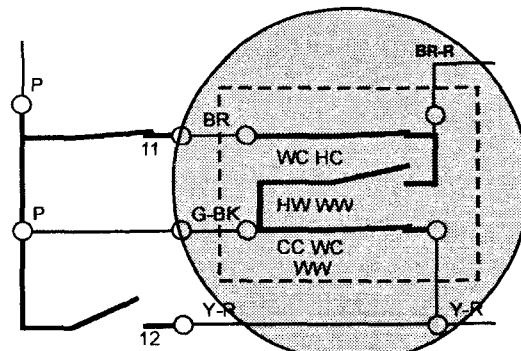

WATER LEVEL SWITCH

To test the water level switch, remove the wires from the water level switch.

With the tub empty, there should be continuity from violet to pink and no continuity between violet and tan.

With the tub full, there should be continuity from violet to tan and no continuity from violet to pink.

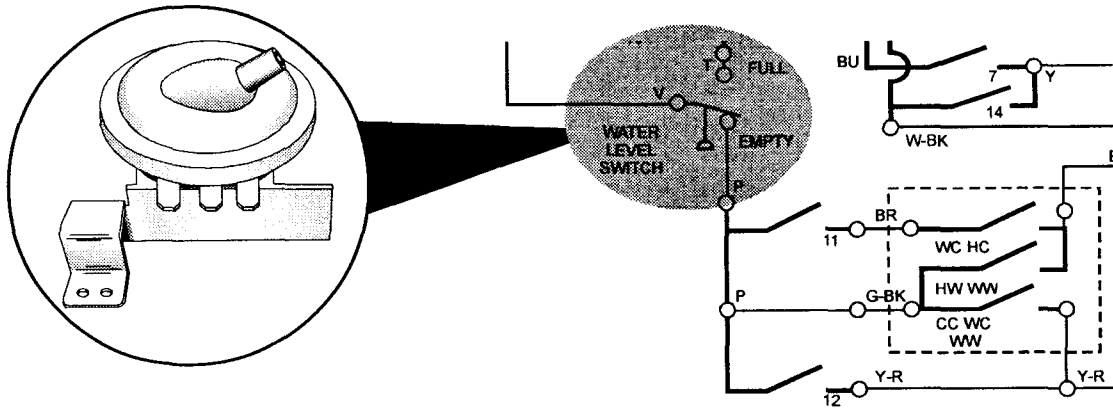

TIMER

To test the timer contacts, select the contacts to be tested; in this case, contact 10.

Using the cycle sequence chart as a reference, turn the timer to the position where the contacts will be closed.

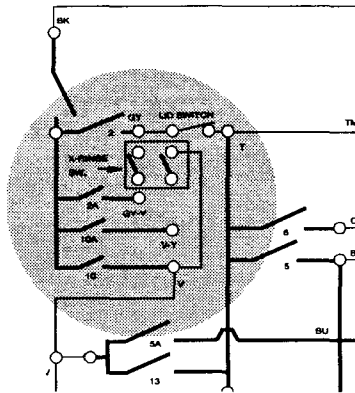

2	0	MACHINE FUNCTION	
T B	T B	FILL - AGITATE	WASH HI
2A 10	L.S.	1/2 TUB DRAIN	DRAIN HI
BYPASS - X.R.	FILL	AGITATE HI	FILL
BK-W	BK-W		
GY-Y	V		
	BK		
	W		
	TERM.		
	2		
	4		
	6		

There should be continuity between the contacts.

Turn the timer to a position where the contacts are open.

There should be no continuity between the contacts.

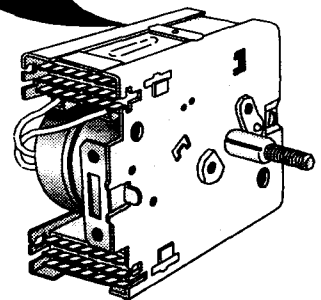
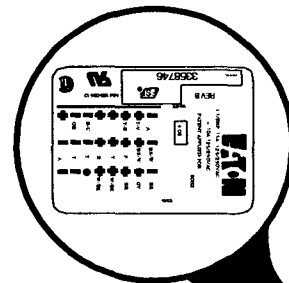

CONFIRMATION OF LEARNING EXERCISE

Test the following components to determine if they are good or bad. Verify with your instructor the results of your testing.

1. Timer bypass contacts (2)
2. Motor centrifugal switch
3. Start capacitor
4. Motor windings

-- NOTE --

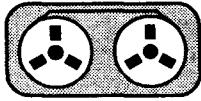

View Section Five of the Video Tape

Section Five

TECH TIPS

WIRING DIAGRAM

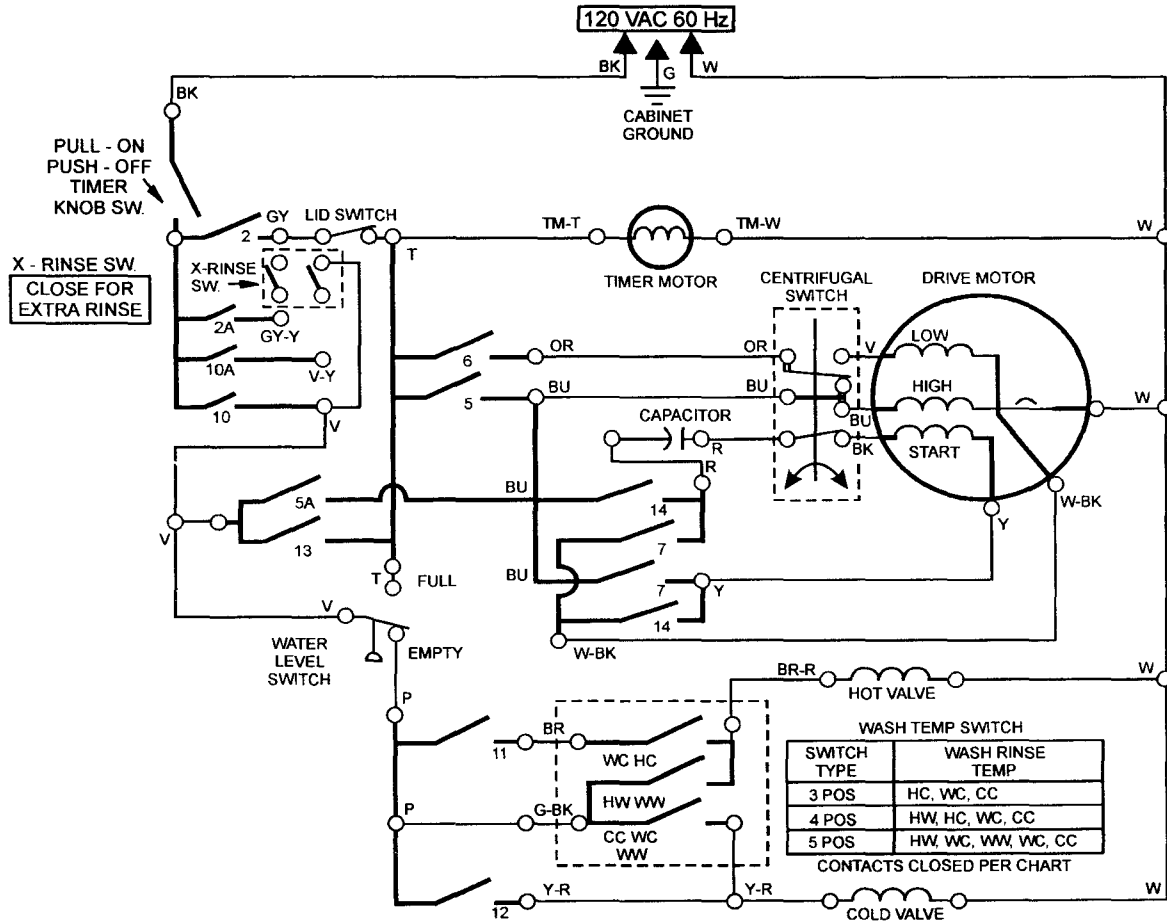

CYCLE CHART

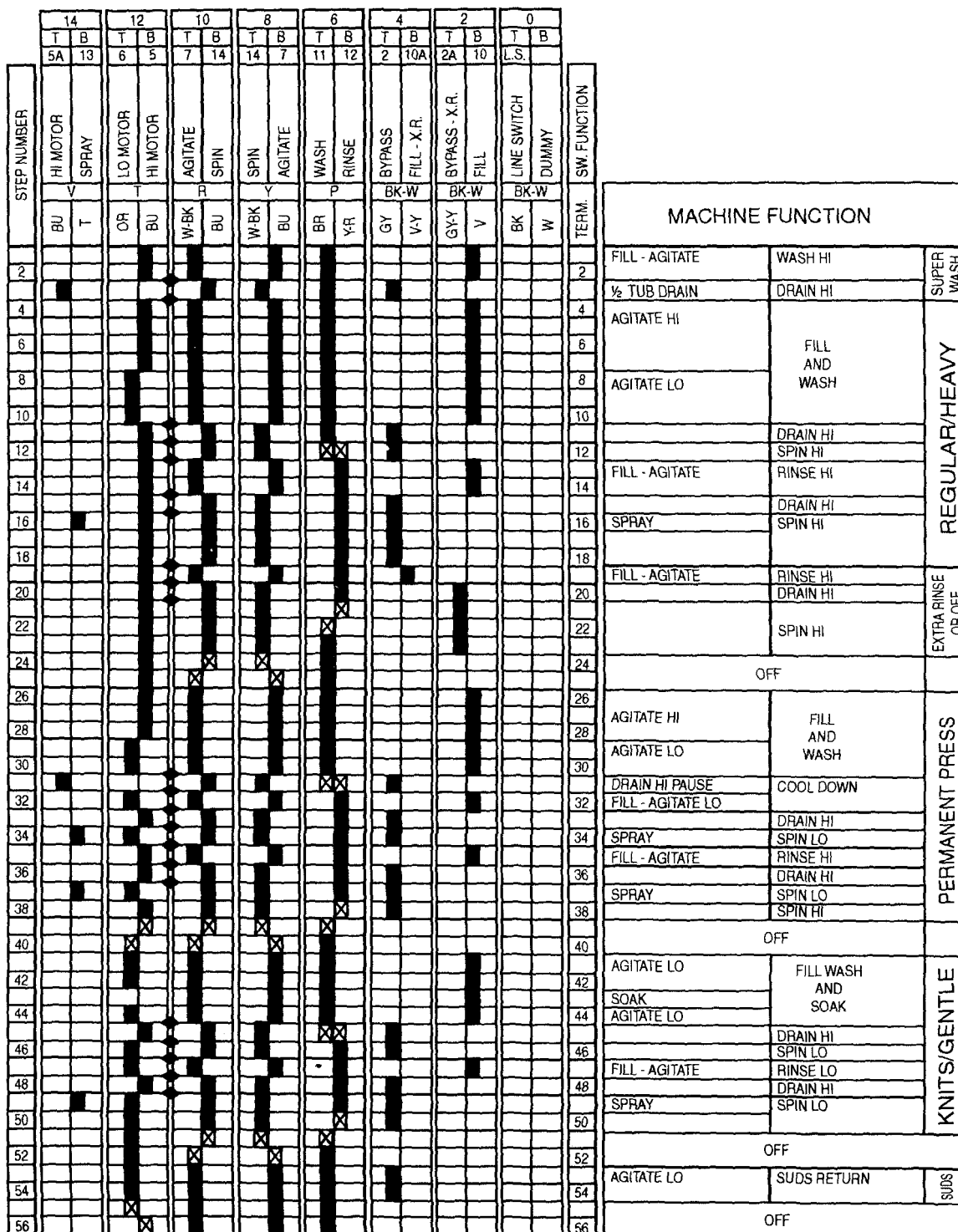

INDICATES MOTOR OFF 4 SECONDS

