



INSTRUCTIONS

-J01624

REV. 06-21-2002

Kit Number 31559-99

HIGH PERFORMANCE 1.4KW STARTER (CHROME)

General

This kit fits 1994 and later Big Twin, Evolution and Twin Cam 88 engines.

See the Service Parts illustration for a list of items contained in this kit. FLT Models will also require a new Oil Spout Gasket, Part Number 62432-93A (available separately).

WARNING

A Service Manual is required to install this kit. The rider's safety depends upon the correct installation of this kit. If the procedure is not within your capabilities or you do not have the correct tools, have your Harley-Davidson dealer perform the installation. Improper installation of this kit could result in death or serious injury.

NOTE

A Service Manual for your model motorcycle is available from your Harley-Davidson dealer.

Installation

WARNING

To protect against shock and accidental start-up of vehicle, disconnect the battery cables, negative cable first, before proceeding. Inadequate safety precautions could result in death or serious injury.

WARNING

Always disconnect the negative battery cable first. If the positive battery cable should contact ground with the negative cable installed, the resulting sparks may cause a battery explosion which could result in death or serious injury.

1. Refer to the SEAT and BATTERY sections of the Service Manual. Remove the seat and disconnect the battery cables, negative cable first.
2. Remove the existing starter according to the instructions found in the STARTER REMOVAL section of the Service Manual.
3. **For all except FLT Models:** Install the new starter according to the STARTER INSTALLATION instructions for the original equipment starter found in the Service Manual. Proceed to Step 4.

For FLT Models: See Figure 1. When installing this starter on FLT model motorcycles, remove the oil filler spout.

CAUTION

Perform this installation when the engine is cool. Working near the exhaust system when the engine is hot could result in minor or moderate injury.

To remove the oil filler spout on FLT Models:

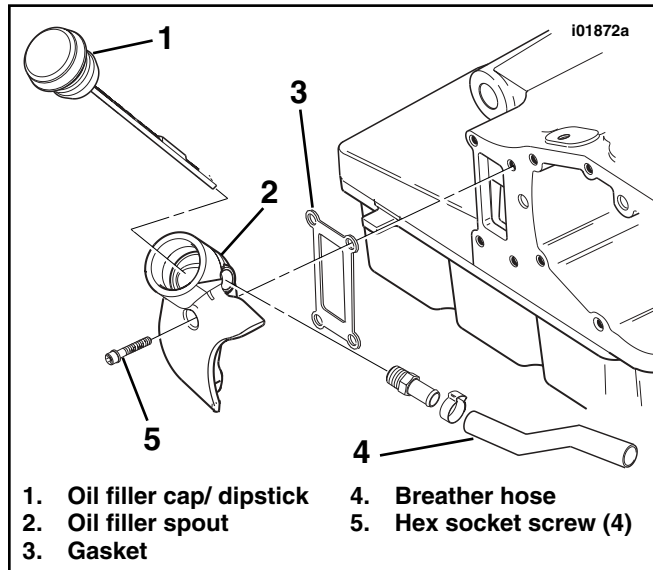

Figure 1. Remove Oil Filler Spout (FLT Models Only)

- a. Place a drain pan under the engine oil pan.
- b. Remove the oil filler cap/ dipstick (1) and set aside.

NOTE

Screws are difficult to reach, but can be carefully removed without disconnecting the exhaust system.

- c. Leave the breather hose (item 4, if so equipped) to the oil filler spout (2). Remove the four hex socket screws (5) holding the spout to the transmission housing. Remove the oil filler spout. Wrap with a shop rag and set aside, out of the way.
- d. Carefully scrape all gasket material from the transmission housing, being sure not to cut into the gasket surface on the transmission housing.
- e. Install the new starter according to the STARTER INSTALLATION instructions for the original equipment starter found in the Service Manual.
- f. Place the new gasket (3) in position, and re-attach the oil filler spout. Tighten the screws to 7-9 ft-lbs (9.5-12.2 Nm).
- g. Re-install the oil filler cap/ dipstick. Check the oil level.

WARNING

Always connect the positive battery cable first. If the positive cable should contact ground with the negative cable installed, the resulting sparks may cause a battery explosion which could result in death or serious injury.

4. Connect the battery cables, positive cable first.
5. Refer to the Service Manual, and follow instructions to install the seat.

WARNING

After installing seat, pull upward on front of seat to be sure it is locked in position. If seat is loose, it could result in shifting during vehicle operation, loss of control of vehicle, death or serious injury.



Service Parts

Part No. 31559-99

Date 06-02

High Performance 1.4KW Starter (Chrome)

sp31559-99b

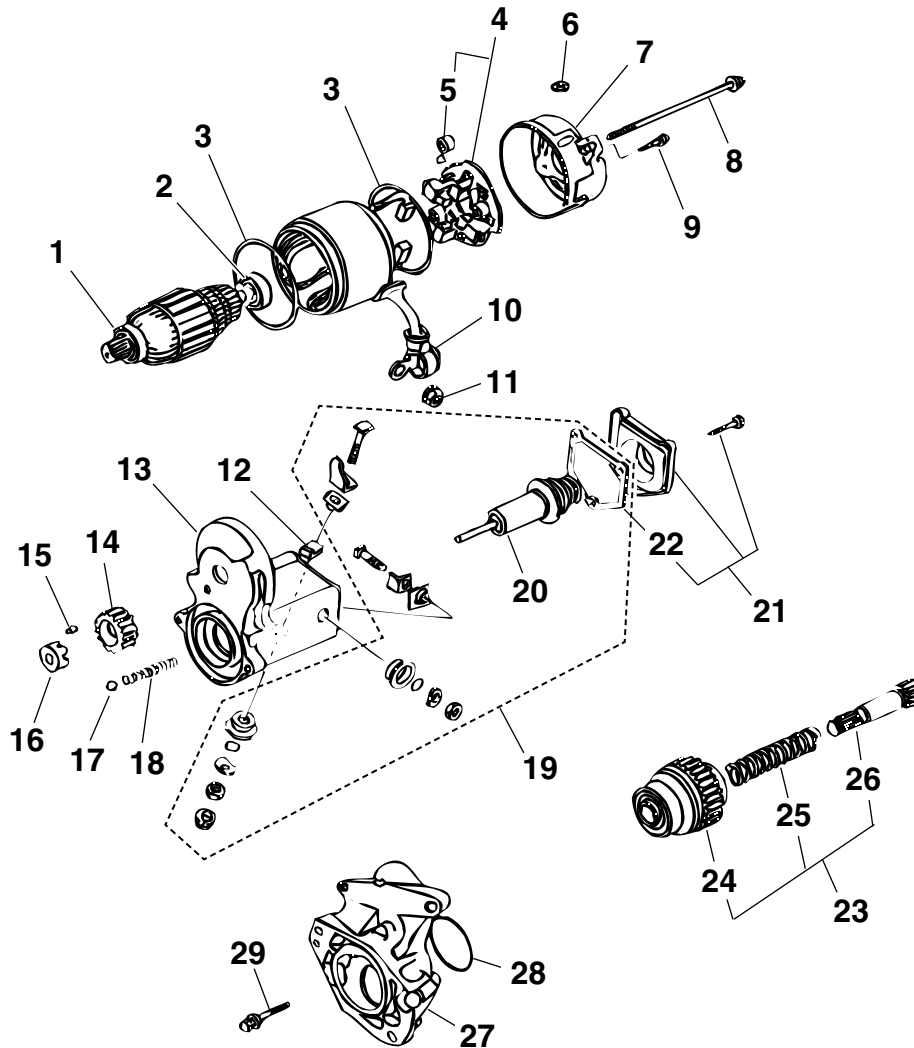

Item	Description	Part No.	Item	Description	Part No.
1	Bearing, Ball (15mm I.D.)	8871	17	Ball, Steel	8879
2	Bearing, Ball (8mm I.D.)	8883	18	Spring, Return	31600-90
3	"O"-Ring, Yoke (2)	31695-90	19	Repair Kit, Starter (incl. Plunger and Gasket)	31604-91
4	Holder Assembly, Starter Brush (includes Brush Springs)	31518-90	20	Plunger Sub-Assembly	31665-90
5	Spring, Starter Brush (4)	31661-90	21	Solenoid Cover Kit (Chrome) (includes Switch Gasket)	31783-00
6	Drain Vent	31660-90	22	Gasket, Switch	31687-90
7	End Frame, Starter	Not sold	23	Clutch Sub-Assembly, Starter (incl. Clutch, Spring & Shaft)	31516-94
8	Through Bolt (Chrome) (2)	3624	24	Clutch, Starter	31663-90
9	Screw, Chrome, w/ "O"-Ring (2)	1036	25	Spring	31692-90
10	Cap, Terminal (Rubber)	31662-90	26	Shaft, Output	31664-94
11	Nut, Flange	3403	27	Housing, Starter	Not sold
12	Washer	6217	28	"O"-Ring	11116
13	Switch Assembly	Not sold	29	Bolt, Starter (w/ Washer) (2)	928
14	Gear, Idler	31525-90	30	Nut w/ Washer (not shown)	31694-90
15	Roller, Idler	9077			
16	Retainer, Idler	31530-90			