



CHA 2016 CONFERENCE & TRADE SHOW DESIGNERS IN ACTION CONTRACT

Anaheim Convention Center • Anaheim, CA • January 7 - 12, 2016

EXHIBITING COMPANY

Company _____ Division _____

Address _____

City _____ State _____ Zip _____ Country _____

Contact _____ Title _____

Tel _____ Ext. _____ Fax _____

Email _____ Website _____

SPACE COST & RESERVATION

Exhibit Space	Qty	Price	CHA Designer Member Discount Price	TOTAL
Designers in Action Display	1	\$500	\$350	
Action Station: First Hour slot		Comp for Display Participants		
Action Station: First Hour slot		\$100	N/A	
Action Station: Add'l Hour slots (each)		\$75	N/A	
PAYMENT ENCLOSED: Full payment required with contract.				\$

SELECT ONE:

Pedestal 2D Wall Display

SPACE PREFERENCES

1. _____ 2. _____

3. _____ 4. _____

CHA Designer Section members exhibiting in the Designers in Action™ area are invited to submit a home-décor craft project to *The Designers in Action™ Home Décor Crafts* eBook.

Yes, I would like to be included in the eBook (see attached flyer for additional information)

DESIGNER DISPLAY: *Showcase your 3D Portfolio*

- (1) 1-meter square pedestal (41" square x 39" tall) – or – (1) 2D wall display (36" wide x 86" tall) with Company Signage
- (1) complimentary Action Station slot with first priority reservations
- Designer Meet & Greet Event
- Two (2) complimentary Exhibitor Badges
- Meeting & Networking Area, built in to Event Space
- Event Marketing Support by CHA at the Mega Show
- Photo & Listing in Designers in Action Handout
- Listing in Online and Printed Show Directory
- Access to Exhibitor Success & ROI Center
- Post Show Event Attendee Contact List
- Black carpet – entire area
- Free area vacuuming on opening morning

ACTION STATION: *Show them what you can do!*

The Designers in Action area contains four Action Stations. These stations will allow designers to showcase their talents and skills LIVE with demos, make-n-takes, book signings – anything you can do, any service you provide – show it here first!

For Designer Members not participating in the Display, the initial 1-hour slot is \$100 and every additional 1-hour slot is \$75. Time slots do not need to be continuous and can range through entire four days of the trade show.

Once purchased, a member of the Designer Council will contact exhibiting designer to set schedule. Designer Members participating in the Designer Stations will receive 1-hour time slot complimentary with first priority reservations (Value \$100).

EXHIBITOR AGREEMENT

The undersigned hereby applies for exhibit space at the CHA 2016 Conference & Trade Show and is authorized to complete this Contract. The undersigned agrees to abide by the *terms and conditions listed on back of this contract and by all the Rules and Regulations* contained in the Exhibitor Service Manual. The undersigned accepts that Show Management will use its best efforts to locate display in accordance with exhibitor preferences, but that it may not be possible based on exhibitor's type of display, and overall space demands.

Authorized Signature _____ Date _____

CHA USE ONLY

RCVD _____

ID# _____

DEP AMT/TYPE _____

BOOTH# _____ TYPE _____

ASSIGNED _____

COMPLETE ALL SECTIONS OF THIS CONTRACT AND RETURN WITH PAYMENT TO:

Craft & Hobby Association • 319 East 54th Street • Elmwood Park, NJ 07407 • Tel: 201-835-1200 • Fax: 201-797-0657

2016 EXPOSITION RULES & REGULATIONS SUMMARY

Designers in Action

The words “Association” or “CHA” shall mean the Craft & Hobby Association.

The word “Exhibitor” shall mean the undersigned of this Contract, and his/her employees.

1. WHO MAY EXHIBIT: Exhibitor must be a current CHA Designer Member or approved Non-Member Designer. A Designer is an individual or firm that conceives, invents, creates or executes decorative crafts or artistic work for licensing or for sale to members of the craft and hobby industry.

2. USE OF EXHIBIT SPACE: Designers may not share display space. Designers may not permit employees of non-exhibiting companies to use their space for any selling purpose. Designers in Action display must be staffed during posted ‘Meet and Greet’ hours, but may be staffed during any open show hours.

3. PAYMENT: Full payment is required with contract. Make all checks payable to Craft & Hobby Association. For credit card payments submit the CHA Credit Card Charge Authorization Form. *For all Member exhibitors:* Full payment of membership dues is required with the Exhibit Space Contract and, if needed, the appropriate Membership Application (with required qualifying documentation).

4. CANCELLATION OF EXHIBIT SPACE: Should Designer be unable to occupy the space contracted, CHA must be immediately notified in writing. If cancellation is received by Friday, October 2, 2015, CHA shall retain 50% of the total cost. If cancellation is received after October 2, CHA shall retain 100% of the total cost. Designer agrees payments as outlined above are to be retained by CHA and that he/she is legally obligated to remit any unpaid balance for such space. If Designer is entitled to a refund for cancelled space, it will be mailed approximately four weeks after the close of the show.

5. REDUCTION OF EXHIBIT SPACE: Notification dates and percentages of penalty fees are the same as for cancelling exhibit space (see above paragraph). Penalty fees are assessed on the total amount of the reduced space.

6. ASSIGNMENT OF SPACE: Space is limited to one per Designer. Exhibit space is assigned on a first come, first served basis. At the discretion of CHA, space may be assigned with due regard to total space available and space allocation requests or working relationships between Exhibitors. The Association reserves the right to alter locations of booths as shown on the official floor plan.

7. DISPLAY RULES: Maximum height from pedestal to top of display is 36”. Designer may not use or affix items to any portion of the base column. Display must be designed to be viewed on all sides (360°) and should include Designer contact information or company name. No additional furniture is permitted.

Displays must be completely set up by 9:00 AM, Saturday, January 9, 2016 and may not be dismantled until 2:00 PM, Tuesday, January 12, 2016. Any exhibitor who fails to wait until the 2:00 PM closing time to begin tear-down is violating show rules.

In the event actual on-site booth construction is in violation of show regulations, CHA show management reserves the right to remedy, which may include the following actions, or other actions at CHA’s sole discretion:

- Reconfiguration of space in accordance with display rules
- Relocation of display
- Removal of booth artifacts and components to bring booth into compliance with display regulations
- Complete removal of display from show floor

Any required actions deemed necessary by CHA show management will be at the sole expense of the exhibitor cited for violation including but not limited to: drayage, labor, security, etc. Designers are required to comply with all applicable rules as detailed in the Exhibitor Service Manual, available at www.craftandhobby.org.

8. EXPOSITION ACTIVITIES: Sales of merchandise for on-site delivery on the show floor during the trade show are prohibited. Costumes, banners or signs must only appear within the confines of the exhibit space leased. Advertising in or about the trade show premises and hotels must be approved in writing by CHA at least 30 days in advance of the show. The Association reserves the right to impose limitations on noise levels and any method of operation that becomes objectionable. The Association reserves the right to remove the source of any objectionable odors.

9. CONDUCT: Exhibitors may only visit other exhibitor’s displays during official show hours. Handling display samples, picking up literature or the taking of photographs of another exhibitor’s booth/product/display is not permitted without the exhibitor’s permission. CHA and its Trade Show observe an Equal Opportunity policy which affords all persons the right to be treated equally.

10. CHILDREN & MINORS POLICY: **No one under the age of 18 is permitted on the Exhibit Hall floor at any time;** this includes babes-in-arms/infants. Exceptions to this policy may be granted for minors involved in the trade and for whom documentation of legal involvement in the business can be supplied and verified. Any minor granted an exception will be allowed supervised access during posted open show hours only. Infants must be restricted to the booth at all times, except entrance and exit from the hall, which must be done directly and the infant must be carried at all times. All playpen style items must be out of attendee view. No strollers are permitted at any time.

11. RESPONSIBILITY: Designer is responsible for reviewing and complying with all rules and regulations set forth in the Exhibitor Service Manual. If the Exhibitor fails to comply in any respect with the terms and conditions of the 2016 Exposition Rules & Regulations, CHA shall have the right, without notice to the Exhibitor to execute the following: A) For violations of display rules – eliminate all trade show points earned for the current year; and B) For other show violations – refuse exhibiting privileges.

12. LIABILITY: The Designer releases CHA from any and all claims of every sort it may have against CHA based upon, arising out of, or in connection with Exhibitor’s occupancy and use of the Trade Show premises, or any action or inaction of any nature of CHA in conjunction with or related to the Trade Show, including, but not limited to: loss; theft; damage; destruction; or delay or non-delivery of goods, display materials and other effects; any injury to Exhibitor, its employees, agents, representatives or guests while on the Trade Show premises; any damage to Exhibitor’s business by reason of the failure to provide space for the exhibit or removal of exhibit; failure to hold the Trade Show as scheduled.

13. INDEMNIFICATION: Designer/Exhibitor agrees to indemnify and hold CHA and its directors, officers, employees, agents and members, harmless with respect to any and all claims, losses, damages, liabilities, judgments, or settlements, including reasonable attorney’s fees, costs, and other expenses incurred by CHA arising or related to: (i) the violation or breach of any term or condition of the agreement between the parties or any of the Trade Show Rules & Regulations by the Exhibitor, its employees and agents; (ii) any activities, including copyright infringement, defamation, or slanderous content, conducted by the Exhibitor during the Trade Show; or (iii) negligent acts or gross misconduct of the Exhibitor while in attendance at the Trade Show. The rights and responsibilities established in this paragraph shall survive indefinitely the termination of the Agreement.

14. CHOICE OF LAW: This Agreement will be governed by and construed in accordance with the laws of the State of New Jersey. The parties hereby consent to the exercise of exclusive jurisdiction by the state or federal courts in the State of New Jersey for any claim relating to the enforcement of, or any rights under, this Agreement.



CREDIT CARD CHARGE AUTHORIZATION FORM

DESIGNERS IN ACTION

Print or Type All Information

Complete this form if you wish to pay by credit card for any of the items listed below

EXHIBITING COMPANY

COMPANY NAME _____ CHA ID# (if known) _____

CREDIT CARD INFORMATION

CHOOSE ONE: MasterCard VISA American Express Discover

THIS CARD IS: Corporate Personal Debit

ACCOUNT NUMBER _____ SECURITY (CCV) CODE _____

EXPIRATION DATE _____

CARDHOLDER'S NAME _____
(PLEASE PRINT)

COMPANY NAME _____
(IF CORPORATE CARD)

CARDHOLDER'S BILLING ADDRESS

ADDRESS _____

CITY _____ STATE _____ ZIP _____ COUNTRY _____

TEL: _____ EXT: _____ FAX: _____

CHA is authorized to charge the above listed credit card for the following expenses:

- Designers in Action – Designer Display & Action Station Fees
- Membership Dues

- ❖ Deposit charged is based on schedule outlined in Exhibit Space Contract's "Payment" paragraph.
- ❖ Balances for Exhibit Space/Membership Dues not paid by deadlines outlined in that "Payment" paragraph will be automatically charged to this credit card.
- ❖ For all Member Exhibitors - Membership Dues, if not previously paid, will be automatically charged upon receipt of Exhibit Space Contract.

CARDHOLDER'S SIGNATURE _____ DATE _____

COMPLETE AND RETURN TO:

Craft & Hobby Association • 319 East 54th Street • Elmwood Park, NJ 07407 • Fax: 201-797-0657

CHA 2016 Conference & Trade Show

DESIGNERS IN ACTION

Anaheim Convention Center • Anaheim, CA • January 7 - 12, 2016

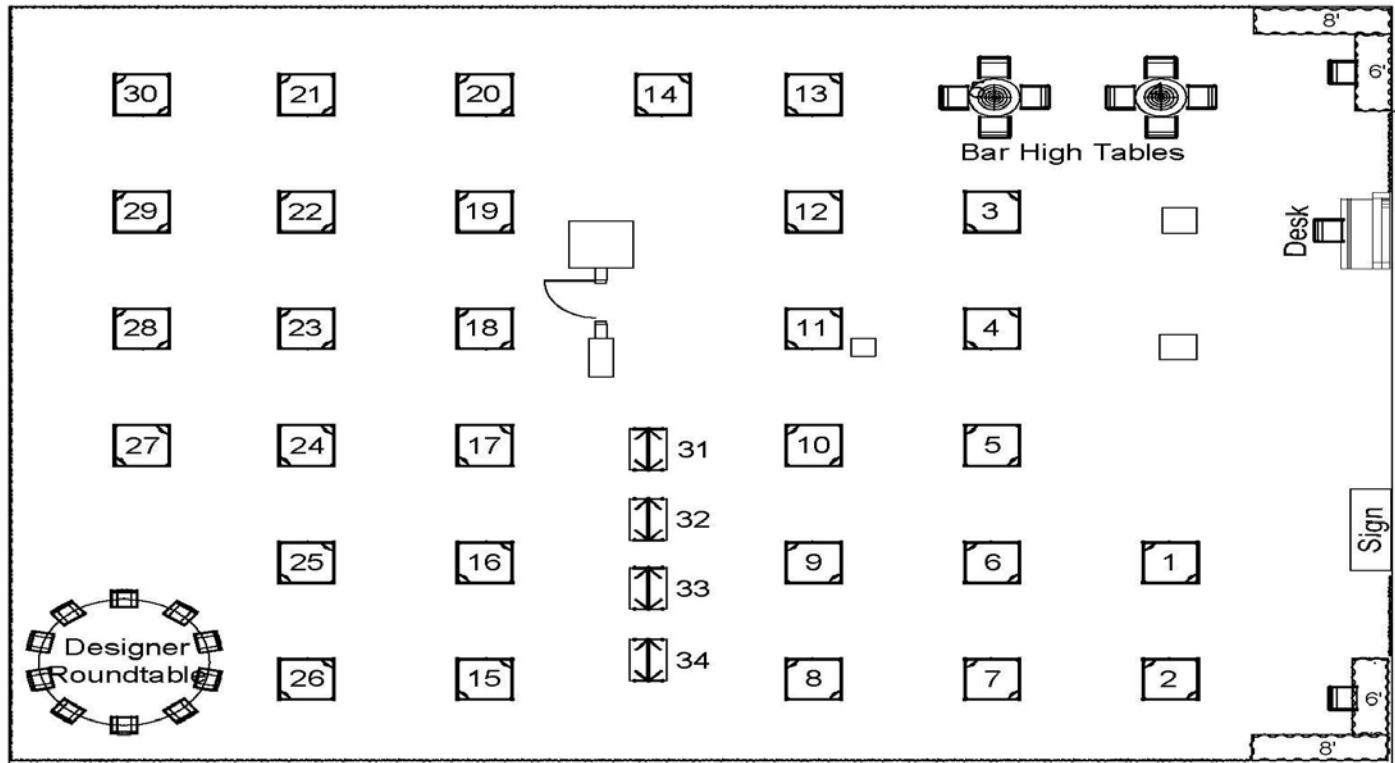

DESIGNER DISPLAY: *SHOWCASE YOUR 3D PORTFOLIO!*

- (1) 1-meter square pedestal (41" square x 39" h) – or – (1) 2D wall display (36" w x 86" h) with Company Signage
- complimentary Action Station slot with first priority reservations
- Designer Meet & Greet Event
- Two (2) complimentary Exhibitor Badges
- Meeting & Networking Area, built in to Event Space
- Event Marketing Support by CHA at the Mega Show
- Photo & Listing in Designers in Action Handout
- Listing in Online and Printed Show Directory
- Access to Exhibitor Success & ROI Center
- Post Show Event Attendee Contact List
- Black carpet – entire area
- Free area vacuuming on opening morning

Price: \$500

CHA Designer Member Discount Price: \$350

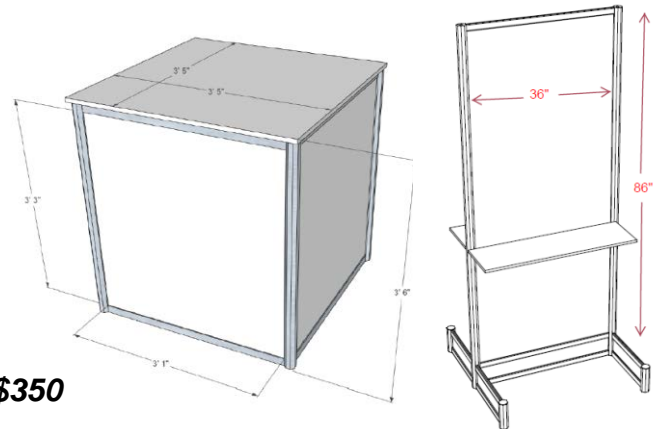

ACTION STATION: *Show them what you can do!*

The Designers in Action area contains four Action Stations. These stations will allow designers to showcase their talents and skills LIVE with demos, make-n-takes, book signings – anything you can do, any service you provide – show it here first! For Designer Members not participating in the Display, the initial 1-hour slot is \$100 and every additional 1-hour slot is \$75. Time slots do not need to be continuous and can range through entire four days of the trade show. Once purchased, a member of the Designer Council will contact exhibiting designer to set schedule. Designer Members participating in the Designer Stations will receive 1-hour time slot complimentary with first priority reservations (Value \$100).

For more information, or to reserve your space, please contact:

Nidia Negrón
Director of Education
201-835-1204
nnegrón@craftandhobby.org

Donna Cennimo
Operations Coordinator
201-835-1217
dcennimo@craftandhobby.org

Designers in Action™ Home Décor Crafts eBook

Introducing *The Designers in Action™ Home Décor Crafts* eBook.

Call for eBook Submissions

CHA Designer Section members exhibiting in the Designers in Action™ area at the 2016 CHA MEGA Show are invited to submit a home-décor craft project to *The Designers in Action™ Home Décor Crafts* eBook.

Artwork

The eBook will have designated categories to provide readers with step-by-step projects for different areas of their homes. The upscale, cheerful projects will be in the following categories:

- Kitchen and Dining
- Bed and Bath
- Family Living
- Children's Room
- Outside the Home



Submission Details

CHA designer exhibitors interested in participating in this eBook must pre-register with the CHA Designer Council by email (CHAdesigners@gmail.com) by September 21, 2015.

Please include with your preregistration:

- A. Your name and company name
- B. Email address and phone number
- C. List and rank the top three categories requests for your eBook project
- D. Your original craft project idea and craft technique you will use in your eBook project
- E. List pertinent supplies and materials you may use

In order to be included in the eBook:

- Your Designer in Action™ pedestal must be paid in full to CHA by October 19, 2015
- Your digital project must be submitted to Council by email no later than October 19, 2015

Questions?

Feel free to contact the CHA Designer Section Council at CHAdesigners@gmail.com with any questions. Manufacturer sponsorship queries may also be directed to the Council Chair, Carol Heppner, at the same email address.