

## INSTALLATION AND SERVICE MANUAL gas-fired unit heaters model HD

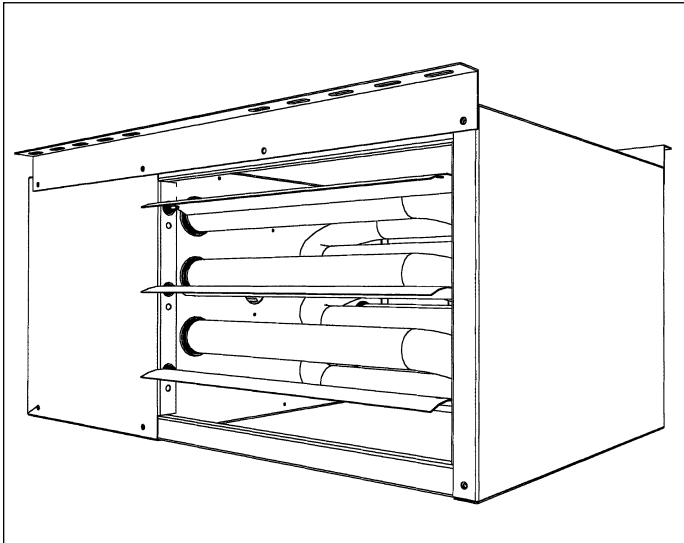

Certified for Commercial and Residential Use



### FOR YOUR SAFETY

The use and storage of gasoline or other flammable vapors and liquids in open containers in the vicinity of this appliance is hazardous.



### CAUTION

To prevent premature heat exchanger failure do not locate ANY gas-fired units in areas where chlorinated, halogenated or acid vapors are present in the atmosphere.

### IMPORTANT

The use of this manual is specifically intended for a qualified installation and service agency. All installation and service of these units must be performed by a qualified installation and service agency.



### WARNING

Improper installation, adjustment, alteration, service or maintenance can cause property damage, injury or death, and could cause exposure to substances which have been determined by various state agencies to cause cancer, birth defects or other reproductive harm. Read the installation, operating and maintenance instructions thoroughly before installing or servicing this equipment.

### FOR YOUR SAFETY

#### WHAT TO DO IF YOU SMELL GAS:

- Open windows.
- Do not try to light any appliance.
- Do not touch any electrical switch; do not use any phone in your building.
- Immediately call your gas supplier from a neighbor's phone. Follow the gas supplier's instructions.
- If you cannot reach your gas supplier, call your fire department.

#### Inspection on Arrival

1. Inspect unit upon arrival. In case of damage, report it immediately to transportation company and your local Modine sales representative.
2. Check rating plate on unit to verify that power supply meets available electric power at the point of installation.
3. Inspect unit upon arrival for conformance with description of product ordered (including specifications where applicable).

THIS MANUAL IS THE PROPERTY OF THE OWNER.  
PLEASE BE SURE TO LEAVE IT WITH THE OWNER  
WHEN YOU LEAVE THE JOB.

# INSTALLATION

## SPECIAL PRECAUTIONS

**THE INSTALLATION AND MAINTENANCE INSTRUCTIONS IN THIS MANUAL MUST BE FOLLOWED TO PROVIDE SAFE, EFFICIENT AND TROUBLE-FREE OPERATION. IN ADDITION, PARTICULAR CARE MUST BE EXERCISED REGARDING THE SPECIAL PRECAUTIONS LISTED BELOW. FAILURE TO PROPERLY ADDRESS THESE CRITICAL AREAS COULD RESULT IN PROPERTY DAMAGE OR LOSS, PERSONAL INJURY, OR DEATH.**

1. Disconnect power supply before making wiring connections to prevent electrical shock and equipment damage. All units must be wired strictly in accordance with wiring diagram furnished with the unit.
2. Turn off all gas before installing unit heaters.
3. Gas pressure to unit heater controls must never exceed 14" W.C. (1/2 psi).  
When leak testing the gas supply piping system, the unit and its combination gas control must be isolated during any pressure testing in excess of 14" W.C. (1/2 psi).  
The unit should be isolated from the gas supply piping system by closing its field installed manual shut-off valve.
4. Check gas inlet pressure at unit upstream from combination gas control. The inlet pressure should be 6-7" W.C. on natural gas or 12-14" W.C. on propane gas. Purging of gas piping should be performed as described in ANSI Z223.1—latest edition or in Canada in CAN/CGA-B149 codes.
5. All units must be vented to the outside atmosphere.
6. Do not install in potentially explosive or flammable atmospheres laden with grain dust, sawdust, or similar air-borne materials. In such applications a blower type heater installed in a separate room with ducting, including appropriate back flow prevention dampers, to the dust-laden room is recommended.
7. Installation of units in high humidity or salt water atmospheres will cause accelerated corrosion resulting in a reduction of the normal life of the units.
8. To prevent premature heat exchanger failure do not locate ANY gas-fired unit heaters in areas where chlorinated, halogenated or acid vapors are present in the atmosphere.
9. Do not locate units in tightly sealed rooms or small compartments (commonly referred to as confined spaces) without provision for adequate combustion air and venting. Combustion air must have access to the confined space through a minimum of two permanent openings in the enclosure, at least one near the bottom. They should provide a free area of one square inch per 1000 BTU per hour input rating of the unit with a minimum of 100 square inches for each opening, whichever is greater.
10. Do not install unit outdoors.
11. Do not locate unit closer to combustible materials than the clearances listed. They are:

Top and Bottom	1"
Vent Connector	4"
Access Side	18"
Non-Access Side	1"
Rear	18"
12. Allow 18" clearance at rear (or 6" beyond end of motor at rear of unit, whichever is greater) and access side to provide ample air for combustion and proper operation of fan.
13. The minimum distance from combustible material is based on the combustible material surface not exceeding 160°F. Clearance from the top of the unit may be required to be greater than the minimum specified if heat damage, other than fire, may occur to materials above the unit heater at the temperature described.
14. Modine unit heaters are designed for use in heating applications with ambient temperatures between -40° F and 90° F.
15. Be sure no obstructions block air intake and discharge of unit heater.
16. Do not attach duct work, air filters, or polytubes to any HD unit heaters.

17. Do not install units below 7' measured from the bottom of the unit to the floor in commercial applications and 5' measured from the bottom of the unit to the floor in residential applications.
18. In aircraft hangars, keep the bottom of the unit at least 10' from the highest surface of the wings or engine enclosure of the highest aircraft housed in the hangar and in accordance with the requirements of the enforcing authority and/or NFPA 409 – latest edition.
19. In commercial garages or other sections of aircraft hangars such as offices and shops which communicate with areas used for servicing or storage, keep the bottom of the unit at least 7' above the floor. In public garages, the unit must be installed in accordance with the Standard for Parking Structures NFPA 88A and the Standard for Repair Garages NFPA 88B. In Canada, installation of unit heaters in airplane hangars must be in accordance with the requirements of the enforcing authority, and in public garages in accordance with the current CAN/CGA-B149 codes.
20. Consult piping, electrical, and venting instructions in this manual before final installation.
21. All literature shipped with this unit should be kept for future use for servicing or service diagnosis. Do not discard any literature shipped with this unit.
22. **SERVICING OR REPAIRING THIS EQUIPMENT MUST BE PERFORMED BY A QUALIFIED SERVICE AGENCY.** Use only Modine approved service replacement parts. A replacement parts list can be found on page 18 of this manual, or may be obtained by contacting Modine Manufacturing Company, Buena Vista, VA. Refer to the rating plate on the unit for complete unit model number, serial number and company address. Any substitution of parts or controls not approved by Modine will be at owners risk.
23. Do not use this appliance if any part has been under water. Immediately call a qualified service technician to inspect the appliance and replace any gas control which has been under water.
24. Should overheating occur, or the gas supply fail to shut off, shut off the manual gas valve to the appliance before shutting off the electrical supply.

© Modine Manufacturing Company 1998

## SPECIAL WARNINGS

1. If you are replacing an existing heater, it may be necessary to resize the venting systems. Improperly sized venting systems can result in vent gas leakage or the formation of condensate. Refer to the National Fuel Gas Code ANSI Z223.1 or CAN/CGA B149.1 or .2 latest edition. Failure to follow these instructions can result in serious injury or death.
2. This heater is equipped with a power exhaust system. **DO NOT** use any additional power exhaust systems or vent dampers. **FAILURE TO FOLLOW THESE INSTRUCTIONS** could result in serious injury or death.

**Figure 2**  
**Typical Unit Suspension**

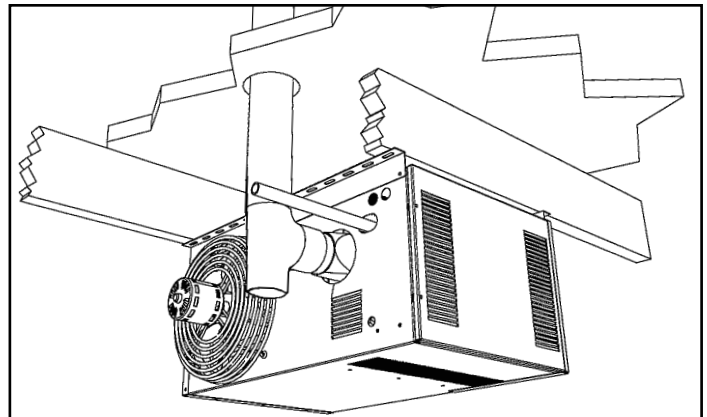

## INSTALLATION

### CAUTION

All literature shipped with this unit should be kept for future use for servicing or service diagnosis. Do not discard any literature shipped with this unit.

Consult piping, electrical, and venting instructions in this manual before final installation.

Do not attach ductwork, air filters, or polytubes to any HD unit heaters.

In the U.S., the installation of these units must comply with the "National Fuel Gas Code," ANSI Z223.1, latest edition (also known as NFPA 54) and other applicable local building codes. In Canada, the installation of these units must comply with local plumbing or waste water codes and other applicable codes and with the current code CAN/CGA-B149.1, "Installation Code for Natural Gas Burning Appliances and Equipment" or CAN/CGA-B149.2, "Installation Code for Propane Burning Appliances and Equipment."

1. All installation and service of these units must be performed by a qualified installation and service agency only as defined in ANSI Z223.1, latest edition or in Canada by a licensed gas fitter.
2. This unit is certified with the controls furnished. For replacement parts, please order according to the replacement parts list on serial plate. Always know your model and serial numbers. Modine reserves the right to substitute other authorized controls as replacements.
3. Unit is balanced for correct performance. Do not alter fan or operate motors at reduced speed.
4. Information on controls is supplied separately.
5. Modine unit heaters use the same burner for natural and propane gases.

### Locating Unit Heaters

### CAUTION

Do not locate units in tightly sealed rooms or small compartments (commonly referred to as confined spaces) without provisions for adequate combustion air and venting. Combustion air must have access to the confined space through a minimum of two permanent openings in the enclosure, at least one near the bottom. They should provide a free area of one square inch per 1000 BTU/Hr input rating of the unit with a minimum of 100 square inches for each opening, whichever is greater.

Turn off all gas before installing unit heaters.

Modine unit heaters are designed for use in heating applications with ambient temperatures between -40° F and 90° F.

Do not install unit outdoors.

### CAUTION

Do not install in potentially explosive or flammable atmospheres laden with grain dust, sawdust, or similar airborne materials. In such applications a blower type heater installed in a separate room with ducting, including appropriate back flow prevention dampers to the dust laden room is recommended.

To prevent premature heat exchanger failure, do not locate ANY gas-fired unit heaters in areas where chlorinated, halogenated or acid vapors are present in the atmosphere.

Installation of units in high humidity or salt water atmospheres will cause accelerated corrosion resulting in a reduction of the normal life of the units.

### CAUTION

In commercial garages or other sections of aircraft hangars such as offices and shops which communicate with areas used for servicing or storage, keep the bottom of the unit at least 7' above the floor. In public garages, the unit must be installed in accordance with the Standard for Parking Structures NFPA 88A and the Standard for Repair Garages NFPA 88B. In Canada, installation of unit heater in airplane hangars must be in accordance with the requirements of the enforcing authority, and in public garages in accordance with the current CAN/CGA-B149 codes.

In aircraft hangars, keep the bottom of the unit at least 10' from the highest surface of the wings or engine enclosure of the highest aircraft housed in the hangars and in accordance with the requirements of the enforcing authority and/or NFPA 409 - latest edition.

In locating units, consider general space-heating requirements. Do not install a unit in a confined space without providing wall openings leading to and from the space. Mounting height (measured from bottom of unit) at which unit heaters are installed is critical. Please refer to mounting height information and heat throw data on page 14 of this manual. The maximum mounting height for any unit is that height above which the unit will not deliver heated air to the floor.

### Adequate Combustion Air

This gas-fired unit heater must be supplied with adequate combustion air. Today's current construction techniques, which result in tighter homes and buildings (or significantly less air infiltration from the outside), makes it more important than ever that heating equipment have adequate combustion air.

Although the requirements for combustion and ventilation air depend on whether or not the unit is installed in a confined or unconfined space, under all conditions, enough air must be provided to ensure there will not be a negative pressure in either a confined or unconfined space. Adequate combustion air (or infiltration), coming from the outdoors will eliminate negative pressure.

### Confined or Unconfined Spaces

The National Fuel Gas Code defines an "unconfined space" as a space whose volume is greater than 50 cubic feet per 1000 Btu/Hr input of the installed appliance(s). A confined space is 50 cubic feet or less per 1000 Btu/Hr input of the installed appliance(s).

Modine does not recommend installing these unit heaters into residential confined spaces. This recommendation is due to the concern that at some point in time, the combustion air openings provided by the installer may become blocked or eliminated by the owner, either intentionally or unintentionally. Despite this recommendation, if these units are installed into a residential confined space, see the National Fuel Gas Code ANSI Z223.1 or CAN/CGA B149.1 or .2 Installation Code, latest edition, for detailed combustion air provisions. These requirements must be adhered to.

Units installed into confined spaces in industrial/commercial installations, must be provided with two permanent openings, one near the top of the confined space and one near the bottom of the confined space. Each opening should have a free area of not less than one square inch per 1,000 BTU per hour of the total input rating of all units in the confined space, freely communicating with interior areas having, in turn, adequate infiltration from the outside.

For further details on supplying combustion air to a confined (tightly sealed) space or unconfined space, see the National Fuel Gas Code ANSI Z223.1 or CAN/CGA B149.1 or .2 Installation Code, latest edition.

# INSTALLATION

## Turning The Unit 180°

All units are produced at the factory with left-side controls, when looking at the unit. If the installation requires that the controls be on the right side, the unit heater can be "turned over". In addition, the following instructions must be followed:

- By turning the unit 180° from the way it was received from the factory, the sides become opposite but the front and back remain in the same relative position. The bottom panel now becomes the top panel and vice-versa.
- Remove the access panel, turn it 180°, and re-attach it to the unit. This is important so that all the information labels can be read.
- Remove the spring loaded deflector blades, turn them over, replace, and adjust so they are open and in a position to direct the heated air down to the floor.

## Unit Suspension

 <b>CAUTION</b>	
Do not install units below 7' measured from the bottom of the unit to the floor in commercial applications and 5' measured from the bottom of the unit to the floor in residential applications.	
Do not locate unit closer to combustible materials than the clearances listed. They are:	
Top and Bottom	1"
Vent Connector	4"
Access Side	18"
Non-Access Side	1"
Rear	18"
Be sure no obstructions block air intake and discharge of unit heaters.	

 <b>CAUTION</b>	
The minimum distance from combustible material is based on the combustible material surface not exceeding 160° F. Clearance from the top of the unit may be required to be greater than the minimum specified if heat damage, other than fire, may occur to materials above the unit heater at the temperature described.	
Allow 18" clearance at rear (or 6" beyond end of motor at rear of unit, whichever is greater) and access side to provide ample air for combustion and proper operation of fan.	

Be sure the means of suspension is adequate to support the weight of the unit (see page 14 for unit weights). For proper operation, the unit must be installed in a level horizontal position. Clearances to combustibles as specified above must be strictly maintained.

Before lifting the heater for suspension, the mounting brackets must be installed. Decide if the unit will be installed as received from the factory; that is with left-side controls when looking at the front of the unit.

If so, remove and retain the (3) screws along the top edge of both the front and back of unit. Align screw holes on mounting bracket with holes along front and back top edges. Secure (1) mounting bracket to front of unit with retained screws. Secure the other mounting bracket to back of unit in a similar way.

If you chose to turn the unit 180° from the way it was received from the factory, the mounting brackets are attached in a similar manner after the unit is turned over.

To suspend unit, secure the mounting brackets to the ceiling joists or truss, using 1/4" screws with 1/2" washers. These 1" - angle, mounting brackets are slotted to accommodate joists on 16" or 24" centerlines.

This heater can also be hung utilizing the same mounting brackets and threaded rod. Attach the threaded rod to the unit mounting brackets, securing with a top and bottom nut.

Next, drill holes into a steel channel or angle iron at the same centerline dimensions as those chosen for the heater that is being installed. The steel channels or angle iron pieces need to span and be fastened to appropriate structural members. Cut the threaded rods to the preferred length, push them through the holes in the steel channel or angle iron and secure with washers and lock nuts, lock washers and nuts, or a double nut arrangement like used on the unit heater mounting brackets.

Finally, the HD gas-fired unit heater can also be installed on a shelf, if so desired. The mounting brackets will need to be attached to the heater the same manner as explained earlier, however, to mount on a shelf the brackets must go on the bottom of the heater. The brackets must be affixed to the shelf using similar screws (1/4" screw with 1/2" washer) as overhead joist or truss mounting. Be sure all clearance to combustible requirements are met.

## Venting

 <b>CAUTION</b>	
All units must be vented to the outside atmosphere.	
A built-in power exhauster is provided - additional external draft hoods (diverters) or power exhausters are not required or permitted.	
Installation must conform with local building codes or in the absence of local codes, with Part 7, Venting of Equipment, of the National Fuel Gas Code, ANSI Z223.1 (NFPA 54) - latest edition. In Canada installation must be in accordance with CAN/CGA-B149.1 for natural gas units, and CAN/CGA-B149.2 for propane units.	

 <b>WARNING</b>	
If you are replacing an existing heater, it may necessary to resize the venting systems. Improperly sized venting systems can result in vent gas leakage or the formation of condensate. Refer to the National Fuel Gas Code ANSI Z223.1 or CAN/CGA B149.1 or .2 latest edition. Failure to follow these instructions can result in serious injury or death.	
This heater is equipped with a power exhaust system. DO NOT use any additional power exhaust systems or vent dampers. FAILURE TO FOLLOW THESE INSTRUCTIONS could result in serious injury or death.	

## Before you start use the following steps to verify that the venting system is adequately sized:

1. Seal any unused openings in the venting system.
2. Inspect the venting system for proper size and horizontal pitch, as required in the National Fuel Gas Code ANSI Z223.1 or CAN/CGA B149.1 or .2 Installation Code-latest edition and these instructions. Determine that there is no blockage or restriction, leakage, corrosion and other deficiencies, which could cause an unsafe condition.
3. In so far as practical, close all building doors and windows and all doors between the space in which the appliance(s) connected to the venting system are located and other spaces of the building. Turn on clothes dryers and any exhaust fans such as range hoods and bathroom exhausts, so they shall operate at maximum speed. Do not operate a summer exhaust fan. Close fireplace dampers.
4. Follow the lighting instructions. Place the appliance being inspected in operation. Adjust thermostat so that the appliance will operate continuously.

# INSTALLATION

- Test all draft hood equipped appliances for spillage at the draft hood relief openings after 5 minutes of main burner operation. Use the flame of a match or candle.
- After it has been determined that each appliance connected to the venting system properly vents when tested as outlined above, return doors, windows, exhaust fans, fireplace dampers and any other gas-burning appliance to their previous conditions of use.
- If improper venting is observed during any of the above tests, the venting system must be corrected.
- If the venting system must be resized, it must conform with the National Fuel Gas Code ANSI Z223.1 or CAN/CGA B149.1 or .2 Installation Code-latest edition. If the venting system must be resized, it should be resized to approach the minimum size as determined using the appropriate table in Appendix G of the National Fuel Gas Code ANSI Z223.1.

**Table 1  
ANSI Unit Heater Venting Requirements**

Category	Description	Venting Requirements
I	Negative vent pressure Non-condensing	Follow standard venting requirements.
II	Negative vent pressure Condensing	Condensate must be drained.
III	Positive vent pressure Non-condensing	Vent must be gas tight.
IV	Positive vent pressure Condensing	Vent must be liquid and gastight. Condensate must be drained.

Note: A **vent** is the vertical passageway used to convey flue gases from the unit or the vent connector to the outside atmosphere. A **vent connector** is the pipe which connects the unit to a vent or chimney. Vent connectors serving Category I appliances shall not be connected into any portion of mechanical draft systems operating under positive pressure.

## Venting Instructions

- All vertically vented HD heaters are category I venting. All horizontally vented HD heaters are category III venting.
- Using Table 1, determine the venting requirements for the category determined above. A category III heater must conform to the venting requirements called out in Table 1, which are detailed in the following sections, as well as additional requirements also detailed in following sections.
- Vertically vented heaters may be vented with either single wall or double wall vent pipe. Follow the double wall manufacturers clearances to combustibles.
- All HD heaters come with a factory installed vent adapter for attaching the vent pipe to the heater. Attach the vent pipe to the adapter with 3 non-corrosive screws. (Drill pilot holes through the vent pipe and adapter prior to screwing in place)
- Do not use any vent pipe smaller than 3". Refer to the National Fuel Gas Code for the minimum material thickness.
- A minimum of 12" straight pipe is recommended from the power exhaust outlet before turns in the vent system. Suspend horizontal runs at a minimum of 3' intervals.
- Avoid venting through unheated spaces when possible. When single wall pipe does pass through an unheated space, insulate runs greater than 5' to minimize condensation. Inspect for leakage prior to insulating and use insulation that is noncombustible with a rating of not less than 350°F. Install a tee fitting at the low point of the vent system and provide a drip leg with a cleanout cap as shown in

Figures 4 and 5. The drip leg should be cleaned annually.

- Keep single wall vent pipe at least 6" from combustible material. The minimum distance from combustible material is based on the combustible material surface not exceeding 160°F. Clearances from the vent pipe (or top of the unit) may be required to be greater than the minimum clearance if heat damage (such as material distortion or discoloration) may occur.
- When a single wall vent passes through a combustible wall or floor, a listed thimble must be used. When a type B double wall vent passes through a combustible wall or floor, follow the vent pipe manufacturers clearances to combustibles. Refer to Figure 3.
- This heater is equipped with a power exhaust system. DO NOT use any additional power exhaust systems or vent dampers. FAILURE TO FOLLOW THESE INSTRUCTIONS could result in serious injury or death.
- All vertically vented HD heaters are category I and must be connected to a factory built chimney or vent complying with a recognized standard, or a masonry (or concrete) lined chimney with a material acceptable to the authority having jurisdiction. Venting into an unlined masonry chimney is not permitted. Refer to the National Fuel Gas Code for common venting.
- Secure all vent joints with at least 3 corrosion-resistant screws. Use an approved vent terminal to reduce down drafts and moisture in the vent.
- The vent must terminate no less than 5' above the vent connector. The top of the vertical stack should extend above any portion of a building within a horizontal distance of 2' (see Figure 4).
- For pitched roof vertical venting, refer to the National Fuel Gas Code for the vertical distance that the cap must extend above the pitched roof.

**Figure 3  
Venting Through Combustible Floor or Roof**

\*See Instructions for attaching single wall pipe to double wall pipe (page 6)

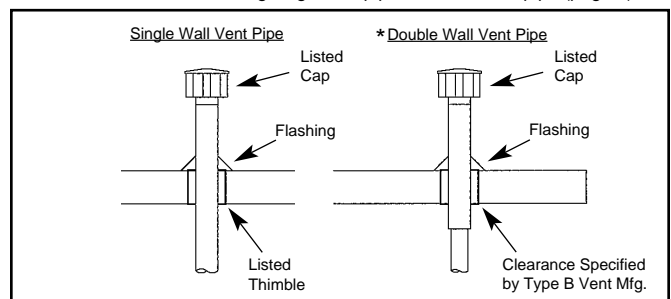

## Venting Through Combustible Wall

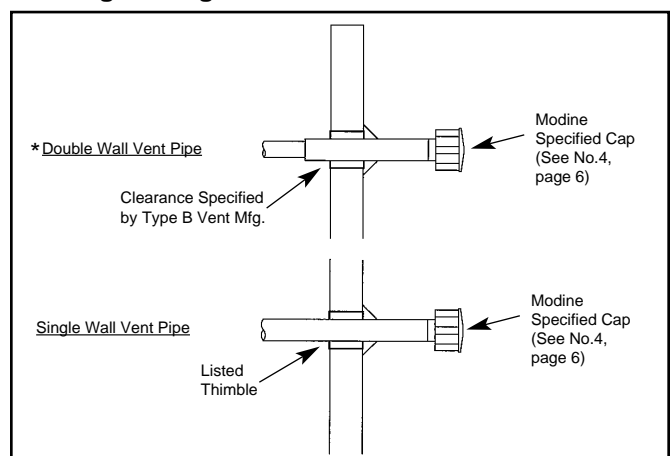

# INSTALLATION

**Figure 4**  
**Vertical Venting Through Flat Roof**

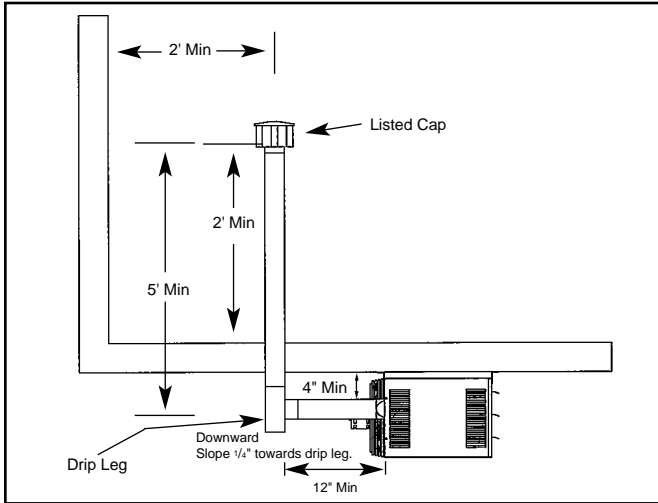

**Figure 5**  
**Vertical Venting Through Sloped Roof**

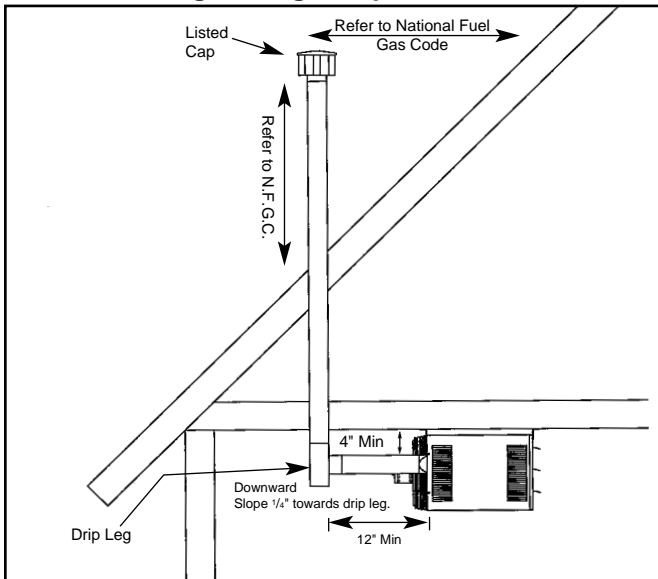

**General Instructions For Double Wall (Type B)**

**Terminal Pipe Installation:**

1. How to attach a single wall vent cap to double wall (type B) vent pipe:
  - A. Look for the "flow" arrow on the vent pipe. Attach the vent cap to the exhaust end of the double wall vent pipe.
  - B. Slide the vent cap inside the pipe.
  - C. Drill a hole through the pipe and the vent cap. Using 3/4" long sheet metal screws, attach the cap to the pipe.
2. How to connect a single wall vent system to a double wall (type B) vent pipe:
  - A. Slide the single wall pipe inside the inner wall of the double wall pipe.
  - B. Drill a hole through both walls of the double wall pipe and through the single wall pipe. Using 3/4" sheet metal screws, attach the two pieces of pipe. Do not over tighten.
  - C. Repeat Step B drilling and inserting (2) additional screws, evenly spaced around the pipe.
  - D. To seal the annular opening, run a large bead of 350°F silastic. The "GAP" between the single and double wall

pipe must be sealed but it is not necessary to fill the full volume of the annular area.

**Additional Requirements For Horizontal Venting:**

1. All HD heaters that are horizontally vented perform as category III appliance. Category III venting has special venting requirements as follows:
  - A. All residential, horizontally vented HD heaters must be vented with an agency certified category III venting system. Agency certified category III venting systems are available from your local vent pipe distributor. Follow the agency certified category III vent manufacturers instructions for installations.
  - B. For commercial and industrial horizontally vented HD heaters you may use either agency certified category III venting systems or single wall galvanized or stainless steel vent pipe. If uncertified single wall vent pipe is used, all joints must be sealed with metallic tape or silastic suitable for temperatures up to 400°F. Wrap tape (2) full turns around the vent pipe.
2. Limit the total equivalent vent pipe length to a minimum of 3' and a maximum of 30', making the vent system as straight as possible. see Figure 8. (The equivalent length of a 3" elbow is 1').
3. The vent system shall terminate at least 3' above any forced air inlet (except direct vent units) located within 10', and at least 4' below, 4' horizontally from, or 1' above any door, window, or gravity air inlet into any building. The bottom of the vent terminal shall be located above the snow line or at least 1' above grade; whichever is greater. When located adjacent to public walkways the vent system shall terminate not less than 7' above grade.
4. All horizontal vents must be terminated with a Gary Steel 1092 or Breidert Type L vent cap. The vent cap must be 12" from side of wall. Refer to Figures 6, 7, and 8.
5. When condensation may be a problem, the vent system shall not terminate over public walkways or over an area where condensate or vapor could create a nuisance or hazard or could be detrimental to the operation of regulators, relief openings, or other equipment.
6. The venting system must be exclusive to a single unit, and no other unit is allowed to be vented into it.
7. When vented horizontally, maintain a 1/4" per foot rise away from the heater. Place a drain tee and clean out near the vent connector. See Figure 6. Where local authorities have jurisdiction, a 1/4" per foot downward slope is acceptable. Use a drain tee with a clean out near the exit of the vent, see Figure 7, or allow the condensate to drip out the end. See Figure 8.
8. When the vent is routed through a combustible wall, use either an agency approved thimble, or where authorities have jurisdiction use type B vent. See Figure 6.

**Figure 6**  
**Horizontal Venting with Upward Pitch**

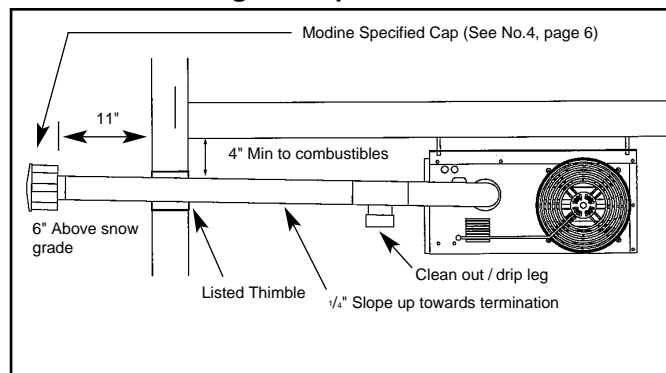

# INSTALLATION

**Figure 7**  
**Horizontal Venting with Downward Pitch**  
**(with drip leg)**

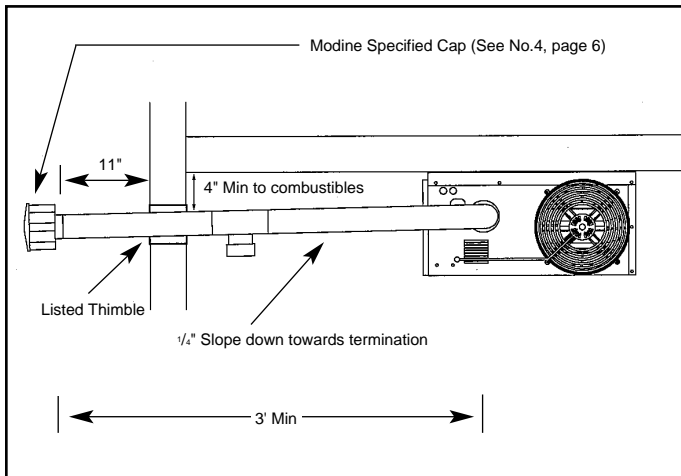

**Figure 8**  
**Horizontal Venting with Downward Pitch**  
**(Condensate Drips Out End)**

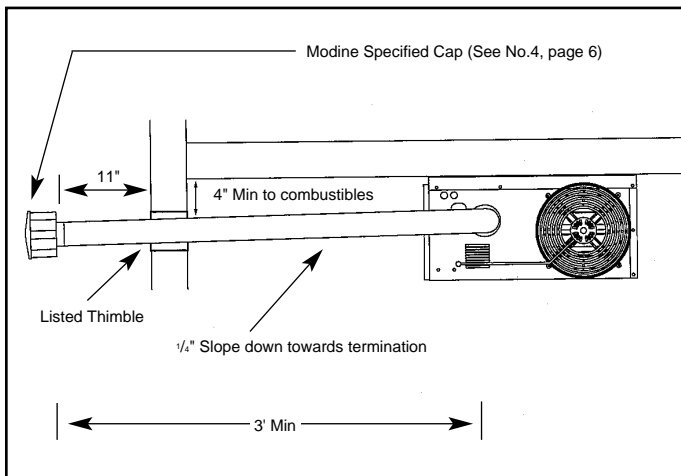

1. Installation of piping must be in accordance with local codes, and ANSI Z223.1, "National Fuel Gas Code," or CAN/CGA-B149 in Canada.
2. Piping to units must conform with local and national requirements for type and volume and gas handled, and pressure drop allowed in the line. Refer to Table 5, to determine the cubic feet per hour (cfh) for the type of gas and size of unit to be installed. Using this cfh value and the length of pipe necessary, determine the pipe diameter from Table 3. Where several units are served by the same main, the total capacity, cfh, and length of main must be considered. Avoid pipe sizes smaller than 1/2". Table 2 allows for the usual number of fittings with a 0.3" W.C. pressure drop. Where the gas supplied has a specific gravity other than 0.60, apply the multiplying factor as given in Table 3.
3. After threading and reaming the ends, inspect piping and remove loose dirt and chips.
4. Support piping so that no strains are imposed on unit or controls.
5. Use two wrenches when connecting piping to unit controls.
6. Provide a drip sediment trap before each unit and in the line where low spots cannot be avoided. (See Figure 9).
7. Take-off to unit should come from top or side of main to avoid trapping condensate.
8. Piping, subject to wide temperature variations, should be insulated.
9. Pitch piping up toward unit at least 1/4" per 15' of horizontal run.
10. Compounds used on threaded joints of gas piping must be resistant to action of liquefied petroleum gases.
11. Purge air before lighting unit by opening inlet pressure at top in combination gas control.
12. After installation, check system for gas leaks, using a soap solution.
13. Install a ground joint union and a manual shut off valve within 6' of the unit including a 1/8" NPT plugged tapping accessible for test gage connection. (See Figure 9).
14. Allow at least 5 feet of piping between any high pressure regulator and unit control string.
15. When leak testing the gas supply piping system, the appliance and its combination gas control must be isolated during any pressure testing in excess of 14" W.C. (1/2 psi)  
 The appliance should be isolated from the gas supply piping system by closing its field installed manual shutoff valve.

## Piping

### CAUTION

Check the gas inlet pressure at the unit upstream of the combination gas control. The inlet pressure must be 6-7" W.C. on natural gas or 12-14" W.C. on propane.

Purging of air from gas lines and piping should be performed as described in ANSI Z223.1-latest edition CAN/CGA-B149 codes.

Gas pressure to unit heater controls must never exceed 14" W.C. (1/2 psi).

When leak testing the gas supply piping system, the appliance and its combination gas control must be isolated during any pressure testing in excess of 14" W.C. (1/2 psi).

The unit should be isolated from the gas supply piping system by closing its field installed manual shut-off valve. This manual shut-off valve should be located within 6' of the heater.

# INSTALLATION

## Piping

**Table 2 – Gas Pipe Capacities**

In Cu. Ft. per Hour with Pressure Drop pf 0.3 in. W.C. with Specific Gravity 0.60.

Length of Pipe in Ft.	Diameter of Pipe - Inches									
	1/2	3/4	1	1-1/4	1-1/2	2	3	4	6	8
15	76	218	440	750	1220	2480	6500	13880	38700	79000
30	73	152	285	590	890	1650	4700	9700	27370	55850
45	44	124	260	435	700	1475	3900	7900	23350	45600
60	50	105	190	400	610	1150	3250	6800	19330	39500
75		97	200	345	545	1120	3000	6000	17310	35300
90		88	160	320	490	930	2600	5400	15800	32250
105		80	168	285	450	920	2450	5100	14620	29850
120			158	270	420	860	2300	4800	13680	27920
150			120	242	380	710	2000	4100	12240	25000
180			128	225	350	720	1950	4000	11160	22800
210				205	320	660	1780	3700	10330	21100
240				190	300	620	1680	3490	9600	19740
270				178	285	580	1580	3250	9000	18610
300				170	270	545	1490	3000	8500	17660
450				140	226	450	1230	2500	7000	14420
600				119	192	380	1030	2130	6000	12480

**Table 3  
Specific Gravity Conversion Factors**

Multiplying factors to be used with table 3 when the specific gravity of gas is other than 0.60.

Natural Gas		Propane Gas	
Specific Gravity	Factor	Specific Gravity	Factor
0.55	1.04	1.50	0.633
0.60	1.00	1.53	0.626
0.65	0.962	1.60	0.612

**Figure 9  
Recommended Piping to Controls**

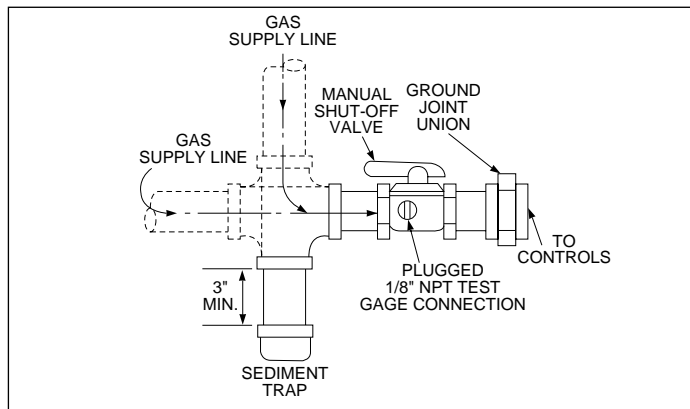



# INSTALLATION

## Wiring



## CAUTION

Disconnect power supply before making wiring connections to prevent electrical shock and equipment damage. All units must be wired strictly in accordance with wiring diagram furnished with the unit.

All field installed wiring must be done in accordance with the National Electrical Code ANSI/NFPA 70 – latest edition or Canadian Electrical Code CSA C22.1 Part 1 or local codes. Unit must be electrically grounded according to these codes. If any of the original wire supplied with the heater must be replaced, replace it with wiring material having a temperature rating of at least 105°C.

The power to these unit heaters should be protected with a circuit breaker.

Location of thermostat should be determined by heating requirements and be mounted on an inside wall about 5' above floor level where it will not be affected by heat from the unit or other sources, or drafts from frequently opened doors. See instructions packed with thermostat.

## OPERATION

### Prior to Operation

Although this unit has been assembled and fire-tested at the factory, the following pre-operational procedures should be performed to assure proper on-site operation.

1. Turn off power.
2. Check fan clearance. Fan should not contact casing when spun by hand.
3. Check all electrical connections to be sure they are secure.
4. If you are not familiar with the unit's controls (i.e. combination gas control), refer to the control manufacturer's literature supplied with the unit.
5. Check that all horizontal deflector blades are open a minimum of 30° as measured from vertical.

### FOR YOUR SAFETY READ BEFORE OPERATING

**WARNING:** If you do not follow these instructions exactly, a fire or explosion may result causing property damage, personal injury or loss of life.

- A. This appliance does not have a pilot. It is equipped with an ignition device which automatically lights the burner. Do not try to light the burner by hand.
- B. BEFORE OPERATING smell all around the appliance area for gas. Be sure to smell next to the floor because some gas is heavier than air and will settle on the floor.

#### WHAT TO DO IF YOU SMELL GAS

- Do not try to light any appliance.
- Do not touch any electric switch; do not use any phone in your building.
- Immediately call your gas supplier from a neighbors phone. Follow the gas supplier's instructions.
- If you cannot reach your gas supplier, call the fire department.

- C. Use only your hand to move the gas control switch. Never use tools. If the switch will not move by hand, don't try to repair it, call a qualified service technician. Force or attempted repair may result in a fire or explosion.
- D. Do not use this appliance if any part has been under water. Immediately call a qualified service technician to inspect the appliance and to replace any part to the control system and any gas control which has been under water.

### OPERATING INSTRUCTIONS

1. STOP! Read the safety information above.
2. Set thermostat to lowest setting.
3. Turn off all electric power to the appliance.
4. This appliance is equipped with an ignition device which automatically lights the pilot. Do not try to light the pilot by hand.
5. Remove the access panel.
6. Move the gas control switch to the "OFF" position.
7. Wait five (5) minutes to clear out any gas. Then smell for gas, including near the floor. If you smell gas, STOP! follow "B" in the safety information above. If you don't smell gas, go to the next step.
8. Move the gas control switch to the "ON" position.
9. Replace control access panel.
10. Turn on all electric power to the appliance.
11. Set the thermostat to the desired setting.
12. If the appliance will not operate, follow the instructions "To Turn Off Gas to Appliance" and call your service technician or gas supplier.

### TO TURN OFF GAS TO APPLIANCE

1. Set thermostat to lowest setting.
2. Turn manual shut-off valve located outside of the unit to the closed position.
3. Turn off all electric power to the appliance if service is to be performed.
4. Remove access panel.
5. Turn the gas valve switch to the "OFF" position.
6. Replace the access panel.

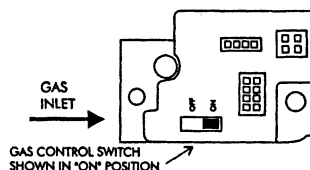

## CHECKING INPUT RATE

### CAUTION

Check the gas inlet pressure at the unit upstream of the combination gas control. The inlet pressure should be 6-7" W.C. on natural gas or 12-14" W.C. on propane. If inlet pressure is too high, install an additional pressure regulator upstream of the combination gas control.

#### Input Adjustments

The gas pressure regulator (part of the combination gas control) is adjusted at the factory for average gas conditions. It is important that gas be supplied to the heater in accordance with the input rating stamped on the serial plate. Actual input should be checked and necessary adjustments made after the heater is installed. Over-firing, a result of too high an input, reduces the life of the unit, and increases maintenance. Under no circumstances should the input exceed that shown on the rating plate.

Input can be determined by the meter-timing method provided other gas equipment connected to the meter is off during the test. If this is not possible, use the pressure method.

Important – Inlet pressure and manifold pressure must be checked with unit in operation when making final adjustments.

#### (A) Meter Timing Method

1. Shut off all other gas-burning equipment, including other pilot lights served by the gas meter.
2. Start the heater and determine the number of seconds it takes to consume 1 cu. ft. of gas. Two basic formulas are useful:

$$F1 = 3600 C/T$$

$$F2 = F1/C$$

where

F1 = input to heater, Btuh.

F2 = input to heater, cu. ft. per hr.

C = heating value of gas, Btu per cu. ft.

T = time to consume 1 cu. ft. of gas in sec.

The heating value of gas may be determined from the local utility or gas dealer.

These are representative values:

GAS	Btu per cu. ft.
Natural	1000-1150
Propane	2500

3. If the seconds for 1 cu. ft. are more (input less) than shown in Table 5 for model being tested, locate the combination gas control and pressure regulator adjustment screw. Remove the cap screw from the pressure regulator and take one clockwise turn at a time on the adjustment screw until the correct time is obtained. If the seconds are less (input greater) than indicated in the table, follow the same procedure in a **counter-clockwise** direction.

If the correct number of seconds cannot be obtained check orifice size. Correct orifices can be obtained from Modine Manufacturing Company, Buena Vista, Virginia. When requesting orifices, state type of gas, heating value, and its specific gravity. Also give model number of unit.

For example, if the input to the heater is 100,000 Btuh and the heating value of the gas is 1000 Btu per cu. ft., then, by the second formula, the input is 100 cu. ft. per hr. Table 4 indicates

the time for one revolution of various size meter dials with various input rates. If a 1 cu. ft. meter dial is used, we proceed down the cu. ft. column to 100 cu. ft. per hr. and then horizontally to the left to determine a time of 36 seconds for one revolution of the dial. Similarly, if the 1/2 cu. ft. dial is used, we determine a time of 18 seconds for one revolution at the required input. After proper firing rate has been achieved, replace regulator cap screw.

**Table 4**

#### Meter-timing Gas

(Time required for one revolution is charted for various size meter dials and various rates of gas input in cu. ft. per hour. To convert to Btuh, multiply by the heating value of the gas used.)

Time for 1 Revolution, Sec.	Input, Cu. Ft. per Hour, when meter dial size is:			
	1/2 cu. ft.	1 cu. ft.	2 cu. ft.	5 cu. ft.
10	180	360	720	1800
12	150	300	600	1500
14	129	257	514	1286
16	112	225	450	1125
18	100	200	400	1000
20	90	180	360	900
22	82	164	327	818
24	75	150	300	750
26	69	138	277	692
28	64	129	257	643
30	60	120	240	600
35	51	103	206	514
40	45	90	180	450
45	40	80	160	400
50	36	72	144	360
55	33	65	131	327
60	30	60	120	300
70	26	51	103	257
80	22	45	90	225
90	20	40	80	200
100	18	36	72	180
120	15	30	60	150



#### (B) Pressure Method

**Figure 9**  
Dials of Typical Gas Meter

The pressure method determines input by measuring the pressure of the gas in the manifold in inches of water.

1. Determine correct manifold pressure from Table 5.
2. Locate combination gas control.
3. Move gas control knob (or lever) to OFF.
4. Remove the 1/8" pipe plug in outlet pressure tap in combination gas control and attach water manometer or "U" tube which is at least 12" high.
5. Follow lighting instructions and turn thermostat up to get unit to fire.
6. If pressure as indicated by "U" tube is less than 1/2" W.C. higher or lower than indicated in Table 5, adjust regulator as described under "Meter-Timing Method," Step 3.

## CHECKING INPUT RATE

If pressure as indicated by "U" tube is more than 1/2" W.C. higher or lower than indicated in Table 5, check inlet pressure at unit. The inlet pressure should be 6-7" W.C. pressure on natural gas and 12-14" W.C. on propane gas.

After adjustment, move gas control knob (or lever) to OFF and replace 1/8" pipe plug. With plug in place follow the lighting instructions to put unit back in service.

**Table 5  
Manifold Pressure & Gas Consumption**

Model	BTU/Cu. Ft. Specific Gravity	Natural	Propane	No. of Orifices
		1050 0.60	2500 1.53	
<b>Manifold Pressure In. W.C.</b>		<b>3.5</b>	<b>10.0</b>	
HD30	CFH	28.6	12.0	2
	Gal/Hr. Propane		.33	
	Sec/cu. ft.	12.6	300	
	Orifice Drill Size	49	56	
HD45	CFH	42.9	18.0	3
	Gal/Hr. Propane		.50	
	Sec/cu. ft.	84	200	
	Orifice Drill Size	49	56	
HD60	CFH	57.1	24.0	4
	Gal/Hr. Propane		.66	
	Sec/cu. ft.	63	150	
	Orifice Drill Size	49	56	
HD75	CFH	71.4	30.0	5
	Gal/Hr. Propane		.83	
	Sec/cu. ft.	50	180	
	Orifice Drill Size	49	56	

**Table 6  
Orifice Drill Sizes with Decimal Equivalents**

Main Burner Orifices			
Drill Size	Dia. Decimal Equivalent	Drill Size	Dia. Decimal Equivalent
49	.0730	55	.0520
50	.0700	56	.0465
51	.0670	57	.0430
52	.0635	58	.0420
53	.0595	59	.0410
54	.0550		

**Figure 10**  
**Major Gas, Electrical Service,**  
**Safety and Other Components**

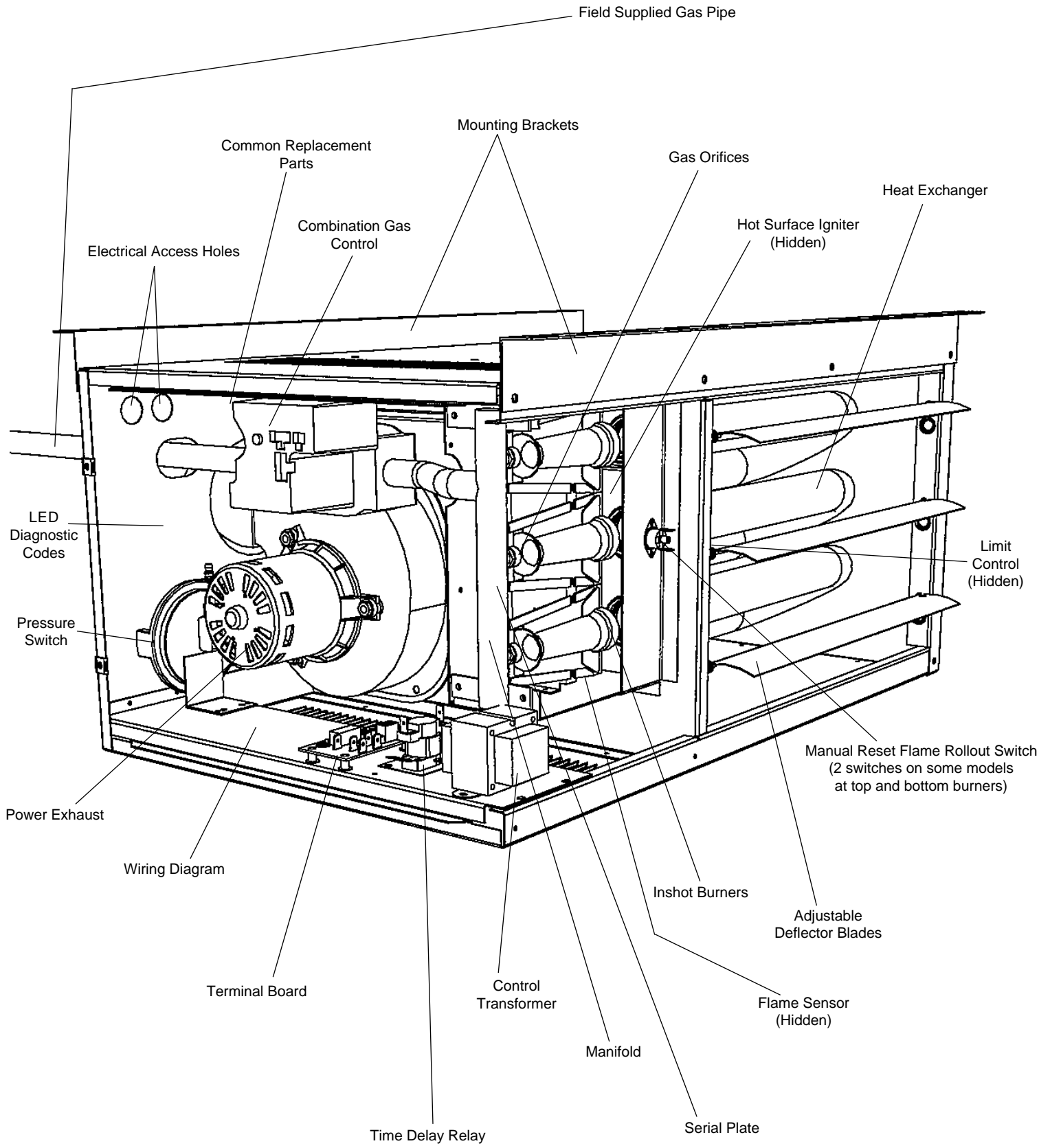

**Figure 11  
HD Unit Heater Rear View**

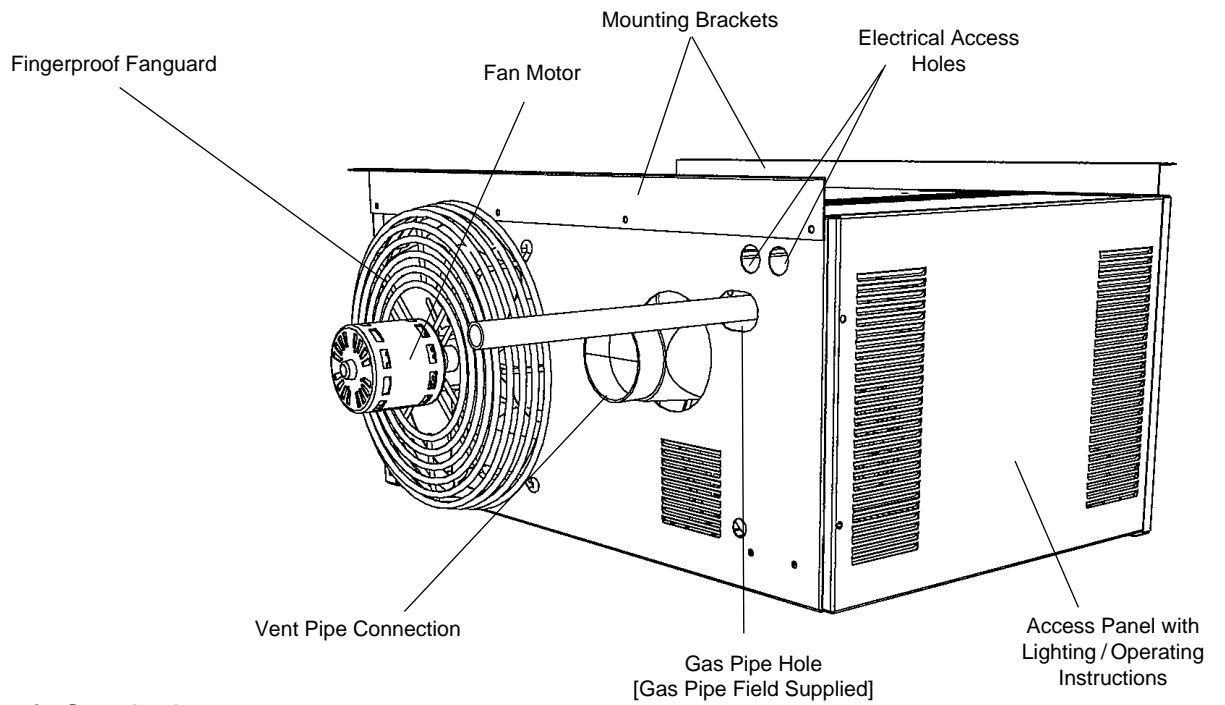

**Figure 12  
HD Unit Heater in Standard  
Mounting Configuration  
(from factory this orientation - brackets not attached)**

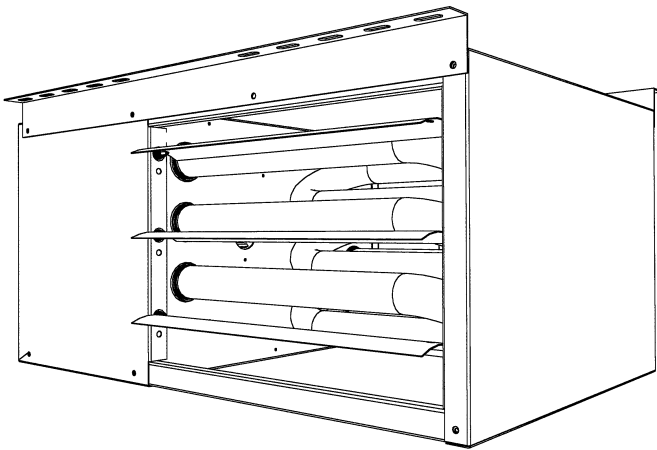

**Figure 13  
HD Unit Heater Turned 180°  
(Access Panel and Heated Air Outlet Change Sides)**

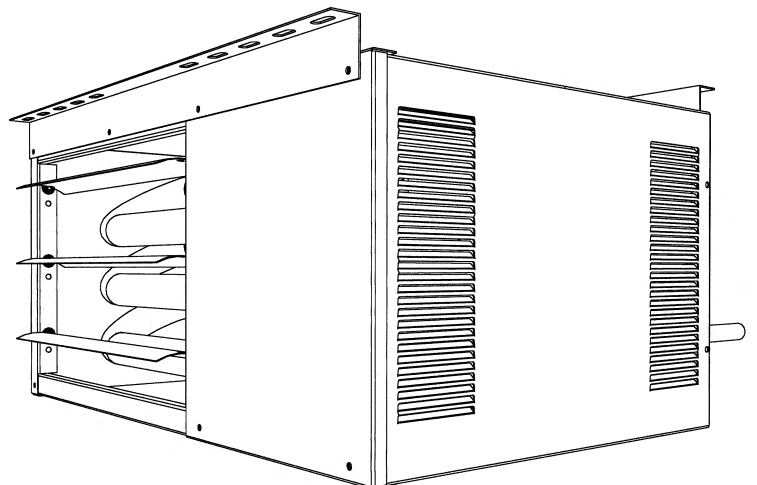

# DIMENSIONS/PERFORMANCE – HD

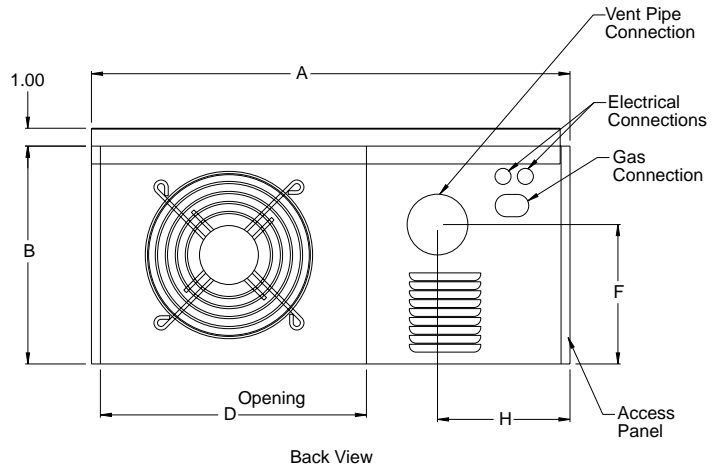
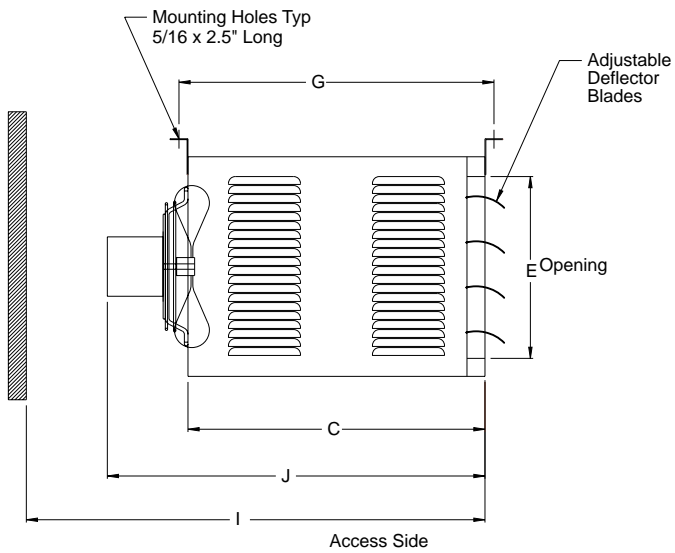

## Dimensions (inches)

Models	HD30	HD45	HD60	HD75
A	26.8	26.8	26.8	26.8
B	12.2	12.2	18.0	18.0
C	16.5	16.5	16.5	16.5
D	14.9	14.9	14.9	14.9
E	10.1	10.1	15.9	15.9
F	7.7	7.7	13.7	13.7
G	18.5	18.5	18.5	18.5
H	7.0	7.0	7.0	7.0
Gas Conn.	1/2	1/2	1/2	1/2
I	28	28	31	31
J	22	22	25	25
Fan Diameter	10	10	14	14
Approx. Shipping Weight (lbs.)	55	60	80	85

## Performance

Models	HD30	HD45	HD60	HD75	
Btu/Hr Input	30,000	45,000	60,000	75,000	
Btu/Hr Output	24,000	36,000	48,000	60,000	
Entering Airflow (CFM)	505	720	990	1,160	
Outlet Velocity	523	749	653	769	
Air Temp. Rise (°F)	44	46	45	48	
Mounting Height (Max ft.)	10	10	12	12	
Heat Throw (ft.)	25	27	36	38	
Motor Data	Horsepower	1/25	1/15	1/12	1/12
	RPM	1,550	1,550	1,625	1,625
	Type	S.P.	S.P.	P.S.C.	P.S.C.
	Amps	1.5	2.4	1.2	1.2
Unit Total Power (Amps)	2.8	3.7	2.5	2.5	
Vent Diameter (in.)	3	3	3	3	

### Mounting

1" - angle, mounting brackets are slotted to accommodate joists on 16" or 24" centerlines.

### Clearances to Combustibles

Top and Bottom	1"
Vent Connector	4"
Access Side	18"
Non-Access Side	1"
Rear	18"

- Ratings shown are for elevation up to 2000 feet above sea level (in Canada, refer to rating plate). For elevations above 2000 ft., ratings should be reduced by approximately 4% for each 1000 ft. above sea level.
- Mounting Height is measured from the bottom of the unit.
- Heat Throws are calculated at 65°F ambient and unit fired at full rated input. Throws for HD30 and HD45 are based on 8-foot mounting heights and at 10-foot heights for HD60 and HD75.
- S.P. = shaded pole, P.S.C. = permanent split capacitor

## MOTOR DATA

### Power Code Description

Power Code	Electric Power	HD30	HD45	HD60	HD75
		Horsepower			
01	115/60/1	1/25	1/15	1/12	1/12

### Motor Data and Total Power Requirement

Voltage	115/60/1			
	HP	Mtr. Amps	Mtr. Rpm	Total Amps
1/25	1.5	1550	2.8	210
1/15	2.4	1550	3.7	280
1/12	1.2	1625	2.5	240

## CONTROL OPTIONS

Control System Description	Control Code No.	Service Voltage	Thermostat Voltage	Type of Gas
<b>Single Stage, Hot Surface Ignition, 100% Shut-Off with Continuous Retry</b> - Utilizes a single-stage combination gas control with built-in ignition control. Gas is lit with a hot surface igniter on call for heat.	34	115V	24V	natural
	74	115V	24V	propane

## CONTROL OPERATING SEQUENCE

### For Hot Surface Ignition

Upon a call for heat from the thermostat, power is supplied to the power exhaustor motor. The unit will go through a purge period and then the hot surface igniter will be energized. After the igniter has warmed up, the main valve in the combination control valve will open to allow gas to flow to the burners. If the fan motor has not already started it will start shortly. If a flame is not sensed for any reason the main valve will close and there will be a short purge period before ignition is tried again. If the flame is not sensed after four tries there will be at least a one hour wait before ignition is tried again.

## SERVICE INSTRUCTIONS – GENERAL

### CAUTION

SERVICING OR REPAIRING THIS EQUIPMENT MUST BE PERFORMED BY A QUALIFIED SERVICE AGENCY. Use only Modine approved service replacement parts. A replacement parts list can be found on page 18 of this manual or obtained by contacting Modine Manufacturing Company, Buena Vista, VA. Refer to the rating plate on the unit for complete unit model number, serial number and company address. Any substitution of parts or controls not approved by Modine will be at the owners risk.

Do not use this appliance if any part has been under water. Immediately call a qualified service technician to inspect the appliance and replace any gas control which has been under water.

Should overheating occur, or the gas supply fail to shut off, shut off the manual gas valve to the appliance before shutting off the electrical supply.

#### General Maintenance

The unit and venting system must be checked once a year by a qualified service technician.

**Only people trained and familiar with the operation of unit heaters and their controls should service this equipment. Before any service, BE SURE TO TURN OFF GAS AT THE MANUAL SHUT-OFF VALVE AHEAD OF THE COMBINATION GAS CONTROL AND TURN OFF ALL ELECTRIC POWER TO THE HEATER.**

1. Service air moving components annually.
  - a. Check fan for fit on motor shaft and for damage to blades.
2. Keep unit free from dust, dirt, grease, and foreign matter, paying particular attention to:
  - a. Combustion air inlets.
  - b. Burners and burner orifices. Turn off gas ahead of the combination gas control and shut off electric power to the heater. Remove the access panel, open the union on the gas line, and disconnect the igniter and sensor wires. Remove the screws that attach the burner tray to the header plate and remove the burner tray and manifold assembly from the heater. Carefully clean the burners with a wire brush or other suitable means. Replace any damaged or deteriorating burners or orifices. Install the burner assembly back on to the header making certain that all screws, pipes and electrical connections are tight.

CAUTION: Be careful when handling the igniter.

    1. Inspect the flame sensor and igniter for deterioration and/or cracks.
    2. Verify that the burners are touching each other at the carryover points. This will ensure flame carryover from burner to burner.
  - c. Clean exterior of heat exchanger tubes.
  - d. Fan blade.
3. Check wiring for possible loose connections.
4. Controls – See control instruction sheets furnished separately with the unit heater.
5. Power exhaust assembly – The power exhaust motor bearings have been lubricated for long life and do not require additional lubrication. In dirty atmosphere, it may be desirable to clean the motor and blower housing and blow out the cooling air passages of the motor with compressed air.

## SERVICE INSTRUCTIONS – SAFETY DEVICES

#### Limit Control (Overheat Switch)

The limit control, mounted in airstream (on access side), will shut off the gas supply to the burners in the event of overheating. It is a single pole, single throw switch. The contacts open to shut the electric gas valve off in the event the unit should overheat. This limit control should operate only when something is seriously wrong with the unit. Anytime this control operates, correct the difficulty immediately or serious damage may result. If the limit control cuts off the gas supply during normal operation:

1. Make certain the deflector blades are open and that there are not any obstructions in the air inlet or outlet.
2. Check actual input to unit against rated input.
3. Check to be sure motor is operating.
4. Check that fan is not loose on motor shaft.
5. Check fan speed against speed on motor nameplate.
6. Check to make sure the venting system is not damaged or blocked. Also check to be sure unit is venting normally and that there is not negative pressure in the building adversely affecting draft.
7. Clean heat exchanger tubes inside and out if necessary.
8. If items 1-7 do not solve the problem, check limit control and replace if necessary. To remove control, first remove access door then remove screws holding control to header.

#### IMPORTANT NOTE:

**The limit control (overheat switch) on this unit heater will shut off the gas should excessive discharge temperatures occur. Do not attempt to control the fan with the limit control. Any change in wiring to attempt to control the fan with the limit control will result in hazardous conditions and void the warranty.**

#### Flame Rollout Switch (or Switches)

The switch (switches), mounted on a bracket above the burners, will shut off the gas supply to the burners in the event of flame rollout. They are a single pole, single throw, manual reset switch. Anytime this control operates, correct the difficulty immediately or serious damage may result.

1. Make sure louvers in casing are not restricted.
2. Make sure power exhaust is operating properly.
3. Make sure vent is not blocked.
4. Clean inside of heat exchanger tubes.
5. Make sure area around orifices is clear.

#### Pressure Switch

The pressure switch (located behind the access panel) will shut off the gas supply to the burners in the event of a problem with the venting system. It is a single pole, single throw switch that is normally open. The contacts close as the power exhauster develops the necessary pressure in the vent system to discharge the flue gases. If it is suspected the pressure switch is not closing or if the switch may be opening under normal conditions;

1. Check the vent system and remove any obstructions in the vent.
2. Check the rubber tube behind the access panel, make sure it is securely connected to the pressure switch and the power exhauster housing.



# SERVICE INSTRUCTIONS – GENERAL

- Check if there is flow at the vent terminal, if there is flow replace the pressure switch, if there is no flow check the power exhauster.

## Hot Surface igniter

The hot surface igniter (located behind the access panel and under the combination gas control) will ignite the gas. It is a ceramic device that will glow red when it heats up to ignite the gas. If the hot surface igniter does not glow red after the purge period, check the resistance of the igniter. If the resistance is greater than 100 ohms then the igniter must be replaced.

To replace the igniter; unplug the lead from the igniter to the combination gas control, remove the two screws holding the igniter (if desired you can remove the manifold assembly to get easier access to the screws). **VERY CAREFULLY** install the new igniter into the panel and plug into the wire harness

## LED Diagnostic Capability

The LED on top of the combination gas control indicates the condition of the control system. The following codes and what they mean follows:

(this information also appears on the unit)

LED DIAGNOSTIC CODES	
Off	No power to system
Bright-Dim	Normal operation
2 Flashes	Pressure switch closed longer than 30 seconds
3 Flashes	Pressure switch open longer than 30 seconds
4 Flashes	Limit Control or Flame Rollout Switch Open
5 Flashes	Flame signal sensed out of sequence
6 Flashes	System lockout

## FOR SERVICE

If a qualified service person cannot solve the problem, consult your local gas company or local Modine representative.

**When servicing, repairing or replacing parts on these units always give the complete Model Number and Serial Number from the unit rating plate.**

The samples below show where these numbers can be found.

## Serial Number Designations (Remove access cover to locate)

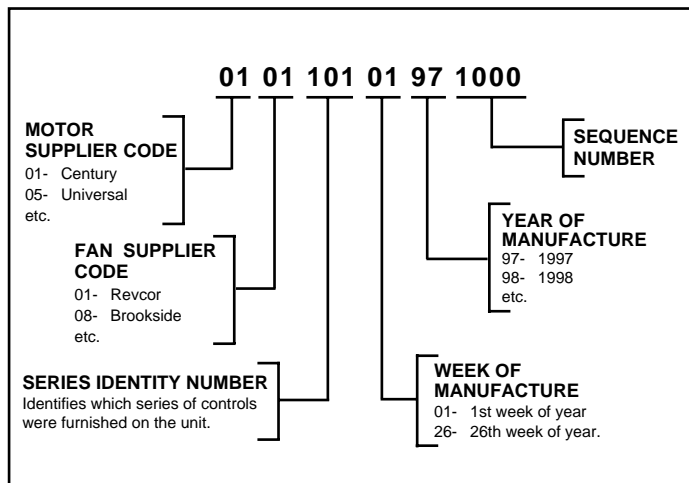

## Model Number Designations (Remove access cover to locate)

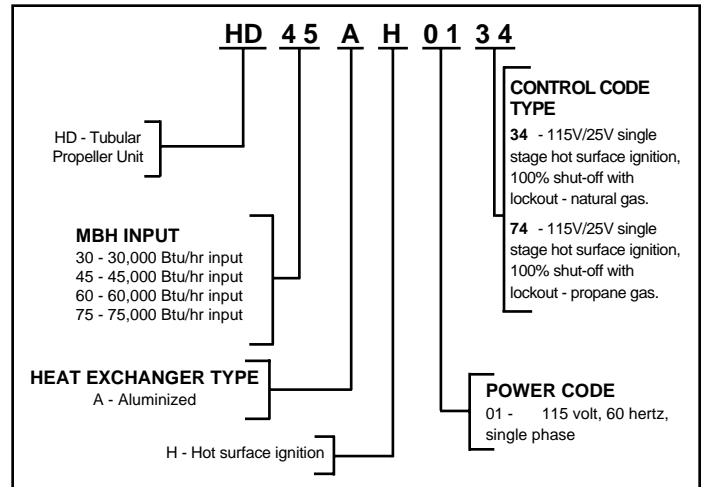

## HD Replacement Parts

When requesting parts please contact your local representative. Please have full model and serial number available. If you require assistance in locating your representative, please call the number located on the pack page.

## HD Unit Heater Wiring Diagram

Wiring Legend	
Factory	Line
Field	24V
Wire Nut	

## UNIT HEATER WIRING DIAGRAM

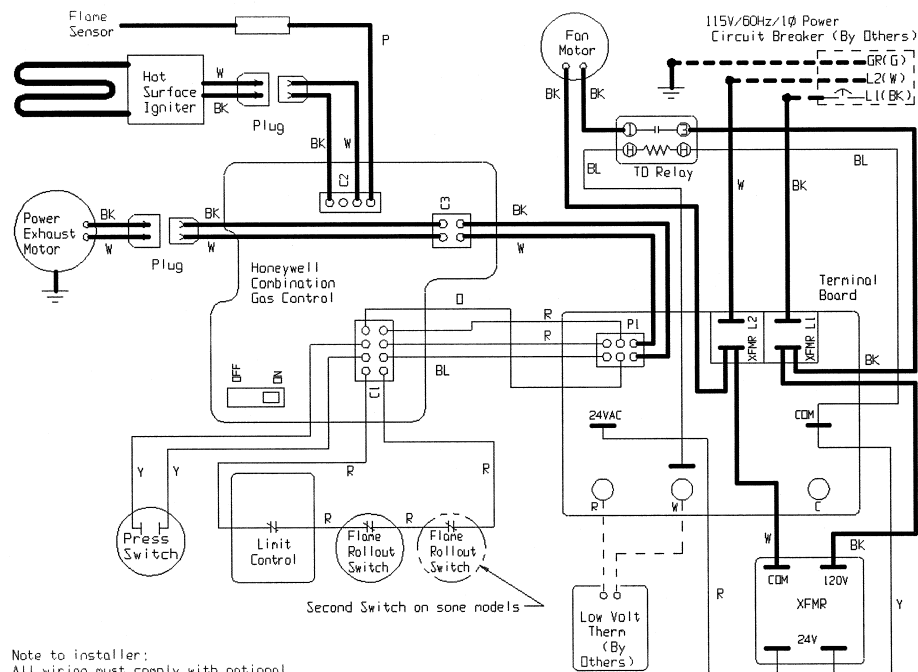

Note to installer:  
All wiring must comply with national electric code and all local codes.

All components must agree with their respective power source.  
Use 105°C wire for replacements.

**Caution**  
Failure to wire this unit according to this wiring diagram may result in injury to the installer or user. For deviations contact the factory.

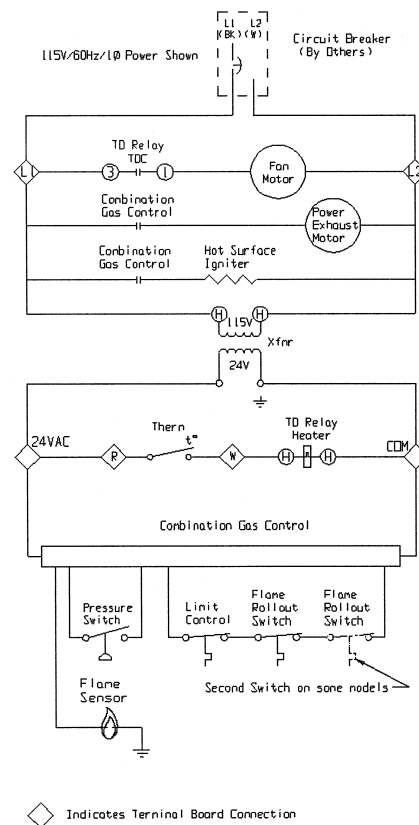

◇ Indicates Terminal Board Connection

5H75034B2 REV

Single-Stage, Hot Surface Ignition, 100% Shut-Off with Continuous Retry, Single-Phase.

**MODINE MANUFACTURING COMPANY.  
LIMITED WARRANTY  
(Residential Use Only)**

**WHAT THIS WARRANTY COVERS**

This warranty covers all defects in material and workmanship in your Modine unit heater, when used for your home or garage.

**WHAT THIS WARRANTY DOES NOT COVER**

Unit heater, or any of its parts:

1. which have been improperly installed or removed.
2. which have been damaged other than by normal use.
3. which have not been properly maintained.
4. which have been exposed to gas input more than 5% higher than specified on the serial plate of the unit heater, resulting in over-firing of the heater.
5. which have been exposed to possibly corrosive chemicals or chemical vapors (such as found in swimming pools), or potentially explosive or flammable atmospheres laden with grain dust, sawdust, or similar air-borne materials.
6. where any defect has been caused by abuse, misuse, neglect, carelessness, or accident.
7. where the serial number of the unit heater has been altered, defaced, or removed.
8. which are used in a confined space without adequate combustion air, such as can be found in more air-tight construction.

**WHO THIS WARRANTY COVERS**

This warranty covers the purchaser of the unit heater or anyone else who owns it during the warranty period.

**HOW LONG THE WARRANTY LASTS**

1. The warranty for the heat exchanger of the unit heater remains in force for ten years from the date you purchased the unit heater.
2. The warranty on all other parts of the heater remains in force for two years from the date you purchased the unit heater.

**WHAT MODINE WILL DO TO CORRECT ANY WARRANTY DEFECTS, AND HOW YOU CAN GET WARRANTY SERVICE**

Modine will have the unit heater, or its parts, repaired or replaced, at its cost by a qualified service agency, if there is a warranty failure. To obtain warranty repairs or replacement of defective parts, you must, within the period of warranty coverage, contact the person from whom you purchased the unit heater. That seller, or the service agency performing service for the seller, will determine whether or not the unit heater, or any of its parts, is in fact defective, and will then either repair or obtain and install the necessary replacement parts for you. If it is determined that the unit heater or parts were not defective, you may be charged for any replacement parts.

**CAUTION** - Do not attempt to repair the unit heater yourself, nor remove it or any of its parts. This must be done by a qualified service agency.

If you have any questions about this warranty, call the person from whom you purchased the unit heater; or a Modine Heating Products Representative at 1-800-828-4328.

**WHAT MODINE WILL NOT DO**

Modine will not reimburse you for any labor costs or service charges related to warranty repairs or replacements.

**INCIDENTAL AND CONSEQUENTIAL DAMAGES  
DISCLAIMED**

This warranty does not cover incidental damages, such as use of substitute heating equipment, or other costs arising from the loss of use of the unit heater. This warranty also does not cover consequential damages, such as the cost of repairing or replacing other property which is damaged when this unit heater does not work properly.

**HOW STATE LAW RELATES TO THIS WARRANTY**

Some states do not allow the exclusion or limitation of incidental or consequential damages so the above limitations or exclusions may not apply to you.

This warranty gives you specific legal rights, and you may also have other rights which vary from state to state.

## COMMERCIAL WARRANTY

Seller warrants its products to be free from defects in material and workmanship, EXCLUSIVE, HOWEVER, of failures attributable to the use of materials substituted under emergency conditions for materials normally employed. This warranty covers replacement of any parts furnished from the factory of Seller, but does not cover labor of any kind and materials not furnished by Seller, or any charges for any such labor or materials, whether such labor, materials or charges thereon are due to replacement of parts, adjustments, repairs, or any other work done. This warranty does not apply to any equipment which shall have been repaired or altered outside the factory of Seller in any way so as, in the judgment of Seller, to affect its stability, nor which has been subjected to misuse, negligence, or operating conditions in excess of those for which such equipment was designed. This warranty does not cover the effects of physical or chemical properties of water or steam or other liquids or gases used in the equipment.

BUYER AGREES THAT SELLER'S WARRANTY OF ITS PRODUCTS TO BE FREE FROM DEFECT IN MATERIAL AND WORKMANSHIP, AS LIMITED HEREIN, SHALL BE IN LIEU OF AND EXCLUSIVE OF ALL OTHER WARRANTIES, EITHER EXPRESS OR IMPLIED, WHETHER ARISING FROM LAW, COURSE OF DEALING, USAGE OF TRADE, OR OTHERWISE, **THERE ARE NO OTHER WARRANTIES, INCLUDING WARRANTY OF MERCHANTABILITY OR FITNESS FOR PURPOSE, WHICH EXTEND BEYOND THE PRODUCT DESCRIPTION CONFIRMED BY BUYER AND SELLER AS OF THE DATE OF FINAL AGREEMENT.**

This warranty is void if the input to the product exceeds the rated input as indicated on the product serial plate by more than 5% on gas-fired and oil-fired units, or if the product in the judgment of SELLER has been installed in a corrosive atmosphere, or subjected to corrosive fluids or gases, been subjected to misuse, negligence, accident, excessive thermal shock, excessive humidity, physical damage, impact, abrasion, unauthorized alterations, or operation contrary to SELLER'S printed instructions, or if the serial number has been altered, defaced or removed.

### Heat Exchangers

For Seller's non-separated combustion gas-fired unit heaters.

BUYER'S REMEDY FOR BREACH OF WARRANTY, EXCLUSIVE OF ALL OTHER REMEDIES PROVIDED BY LAW, IS LIMITED TO REPAIR OR REPLACEMENT AT THE FACTORY OF SELLER, ANY HEAT EXCHANGER WHICH SHALL, WITHIN TEN YEARS FROM DATE OF FIRST BENEFICIAL USE BY BUYER OR ANY OTHER USER, WITHIN TEN YEARS FROM DATE OF RESALE BY BUYER OR ANY OTHER USER, WITHIN TEN YEARS FROM DATE OF RESALE BY BUYER IN ANY UNCHANGED CONDITION, OR WITHIN ONE HUNDRED TWENTY-SIX MONTHS FROM DATE OF SHIPMENT FROM SELLER, WHICHEVER OCCURS FIRST, BE RETURNED TO SELLER WITH TRANSPORTATION CHARGES PREPAID AND WHICH THE EXAMINATION OF SELLER SHALL DISCLOSE TO HAVE BEEN DEFECTIVE; EXCEPT THAT WHEN THE PRODUCT IS TO BE USED BY BUYER AS A COMPONENT PART OF EQUIPMENT MANUFACTURED BY BUYER, BUYER'S REMEDY FOR BREACH, AS LIMITED HEREIN, SHALL BE LIMITED TO ONE YEAR FROM DATE OF SHIPMENT FROM SELLER. FOR GAS-FIRED PRODUCTS INSTALLED IN HIGH HUMIDITY APPLICATIONS AND UTILIZING STAINLESS STEEL HEAT EXCHANGERS, BUYER'S REMEDY FOR BREACH, AS LIMITED HEREIN, SHALL BE LIMITED TO TEN YEARS FROM DATE OF SHIPMENT FROM SELLER.

**Heat Exchanger (Condensers)** for all Seller's products except non-separated combustion gas-fired unit heaters, and Burners and Sheet Metal for all products.

BUYER'S REMEDY FOR BREACH OF WARRANTY, EXCLUSIVE OF ALL OTHER REMEDIES PROVIDED BY LAW, IS LIMITED TO REPAIR OR REPLACEMENT AT THE FACTORY OF SELLER, ANY HEAT EXCHANGER (CONDENSER) OR BURNER WHICH SHALL, WITHIN ONE YEAR FROM DATE OF FIRST BENEFICIAL USE BY BUYER OR ANY OTHER USER, WITHIN ONE YEAR FROM DATE OF RESALE BY BUYER IN ANY UNCHANGED CONDITION, OR WITHIN EIGHTEEN MONTHS FROM DATE OF SHIPMENT FROM SELLER, WHICHEVER OCCURS FIRST, BE RETURNED TO SELLER WITH TRANSPORTATION CHARGES PREPAID AND WHICH THE EXAMINATION OF SELLER SHALL DISCLOSE TO HAVE BEEN

DEFECTIVE; EXCEPT THAT WHEN THE PRODUCT IS TO BE USED BY BUYER AS A COMPONENT PART OF EQUIPMENT MANUFACTURED BY BUYER, BUYER'S REMEDY FOR BREACH, AS LIMITED HEREIN, SHALL BE LIMITED TO ONE YEAR FROM DATE OF SHIPMENT FROM SELLER.

### All Other Components Excluding Heat Exchanger (Condenser), Burner, and Sheet Metal

All Seller Heating Products except Direct-Fired and Weatherpack®.

BUYER'S REMEDY FOR BREACH OF WARRANTY, EXCLUSIVE OF ALL OTHER REMEDIES PROVIDED BY LAW, IS LIMITED TO REPAIR OR REPLACEMENT AT THE FACTORY OF SELLER, ANY PART OR PARTS WHICH SHALL, WITHIN TWO YEARS FROM DATE OF FIRST BENEFICIAL USE BY BUYER OR ANY OTHER USER, WITHIN TWO YEARS FROM DATE OF RESALE BY BUYER IN ANY UNCHANGED CONDITION, OR WITHIN THIRTY MONTHS FROM DATE OF SHIPMENT FROM SELLER, WHICHEVER OCCURS FIRST, BE RETURNED TO SELLER WITH TRANSPORTATION CHARGES PREPAID AND WHICH THE EXAMINATION OF SELLER SHALL DISCLOSE TO HAVE BEEN DEFECTIVE; EXCEPT THAT WHEN THE PRODUCT IS TO BE USED BY BUYER AS A COMPONENT PART OF EQUIPMENT MANUFACTURED BY BUYER, BUYER'S REMEDY FOR BREACH, AS LIMITED HEREIN, SHALL BE LIMITED TO ONE YEAR FROM DATE OF SHIPMENT FROM SELLER.

Direct-Fired and Weatherpack®.

BUYER'S REMEDY FOR BREACH OF WARRANTY EXCLUSIVE OF ALL OTHER REMEDIES PROVIDED BY LAW IS LIMITED TO REPAIR OR REPLACEMENT AT THE SELLER'S OPTION ANY PART OR PARTS WHICH SHALL WITHIN A PERIOD OF ONE YEAR FROM DATE OF FIRST BENEFICIAL USE BY BUYER OR ANY OTHER USER, WITHIN ONE YEAR FROM DATE OF RESALE BY BUYER IN ANY UNCHANGED CONDITION, OR WITHIN 18 MONTHS FROM DATE OF SHIPMENT FROM SELLER, WHICHEVER OCCURS FIRST, BE RETURNED TO SELLER WITH TRANSPORTATION CHARGES PREPAID AND WHICH THE EXAMINATION OF THE SELLER SHALL DISCLOSE TO HAVE BEEN DEFECTIVE.

BUYER AGREES THAT IN NO EVENT WILL SELLER BE LIABLE FOR COSTS OF PROCESSING, LOST PROFITS, INJURY TO GOODWILL, OR ANY OTHER CONSEQUENTIAL OR INCIDENTAL DAMAGES OF ANY KIND RESULTING FROM THE ORDER OR USE OF ITS PRODUCT, WHETHER ARISING FROM BREACH OF WARRANTY, NONCONFORMITY TO ORDERED SPECIFICATIONS, DELAY IN DELIVERY, OR ANY LOSS SUSTAINED BY THE BUYER.

### Cancellation — Inspection — Rejection

Orders for material or equipment are not cancelable, either in whole or part, nor is material returnable for credit.

Seller will replace any material or equipment not conforming to the product description as agreed upon by Buyer and Seller as of the date of shipment only if the Buyer notifies Seller, at the address on the Seller's INVOICE, of the particular detail of non-conformance or defect of such material or equipment, by written or electronic notice, either before or immediately upon delivery, and only if such non-conforming material or equipment is returned, sold, or otherwise disposed of in accordance with instructions of Seller. Buyer agrees to inspect all of the ordered material or equipment either before or upon delivery and waives all his rights to reject or refuse to accept any non-conforming material or equipment unless notice is given to Seller in the aforesaid time and manner. Buyer may inspect the ordered material at Seller's plant in an area designated by Seller. Buyer agrees that the right of rejection of non-conforming material or equipment, as limited herein, and the right to replacement by Seller with material or equipment, as limited herein, and the right to replacement by Seller with material or equipment conforming to the ordered specifications, are exclusive of all other remedies provided by law. Written authorization must be issued by Seller before any material is returned to its plant.

### Governing Law

It is agreed that the parties hereto intend that all questions as to validity, interpretation, and required performance arising out of this contract are to be governed by the laws of the State of Wisconsin (Uniform Commercial Code).

As Modine Manufacturing Company has a continuous product improvement program, it reserves the right to change design and specifications without notice.

• FOR RESIDENTIAL USE SEE LIMITED CONSUMER WARRANTY ON PREVIOUS PAGE



### Commercial HVAC&R Division

Modine Manufacturing Company  
1221 Magnolia Avenue  
Buena Vista, Virginia 24416  
Phone: 1.800.828.4328 (HEAT)  
Fax: 540.261.1903 (Service & Parts)  
www.modine.com