

LIFTSMART

ELEVATING INNOVATION

MLC PARTS & SERVICE MANUAL

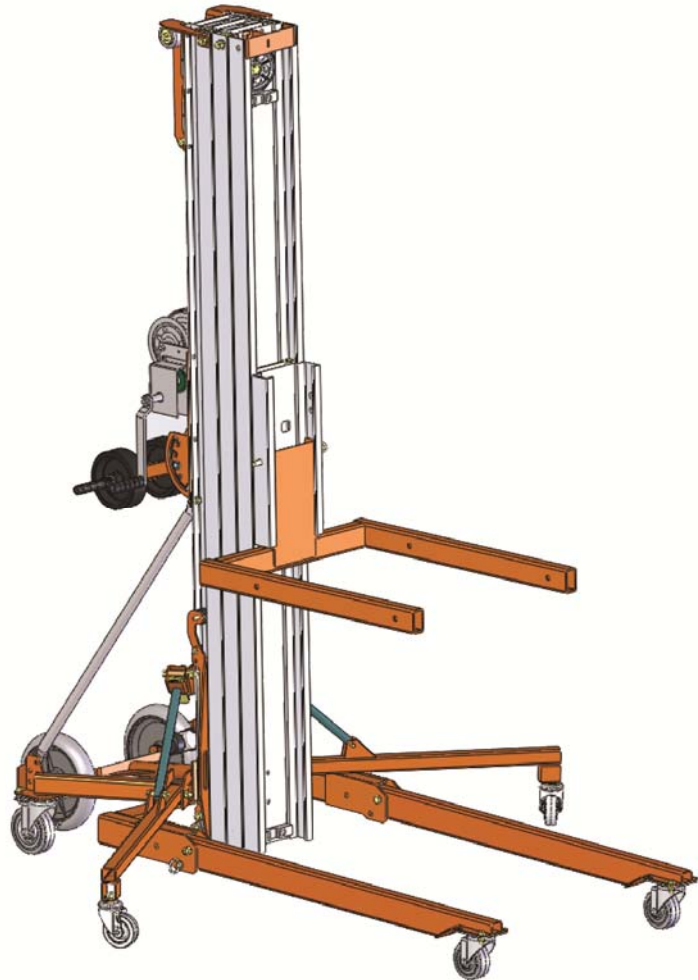

MLC CONSTRUCTION PRO SERIES MATERIAL LIFTS

It is the responsibility of the user to read, understand and obey all safety rules before attempting to perform maintenance on this equipment. This includes all rules and instructions set forth by the manufacturer, as well as any local laws and regulations governing the safe use of this equipment.

It is strongly recommended that only trained and authorized personnel perform maintenance on this material lift.

This manual is intended to be used in conjunction with the *MLC Construction Pro Series Operator's Manual*. Failure to read, understand and obey all safety rules in both manuals may result in serious injury or death.

LiftSmart is dedicated to the continuous improvement of this and all LiftSmart products. Therefore, technical information contained in this manual is subject to change without notice. Direct any questions regarding errors or discrepancies in this manual to LiftSmart.

CONTACT US:

LiftSmart
1370 Decision Street
Suite A
Vista, CA 92081

P.O. Box 4186
Oceanside, CA 92052-4186

Phone/Fax: 800.717.3079
www.liftsmart.net

Patents Pending.

CONTENTS		Page
1 - SAFETY		1
	Maintenance Safety	2
2 - INSPECTIONS		3
	Daily Inspections	4
	Visual Inspection	5
	Function Tests	5
	Quarterly Inspections	6
	Cleaning the Mast Sections	7
	Inspecting the Winch	7
	Lubricating the Winch	7
	Annual Inspections	8
	Inspecting the Mast Sections	9
3 - TROUBLESHOOTING		11
4 - REPAIR		13
	Removing the Base	14
	Disassembling the Mast	15
	Assembling the Mast	16
	Replacing a Pulley	17
	Additional Repairs	18
5 - PARTS		19
	Decals - ANSI	20
	Decals - CE	22
	Base Assembly	24
	Leg Assembly	26
	Transport Wheel Assembly	28
	Mast Assembly (I) - First Mast Assembly	30
	Mast Assembly (II) - Center Mast Assembly	32
	Mast Assembly (III) - Front Mast & Carriage	34
	Back of the Mast Assembly	36
	Winch Assembly	38
	Adjustable Forks Assembly	40
	Flat Forks Assembly	42
	Boom Assembly / Platform Assembly	44
	Pipe Cradle/Fork Extension	46
	Additional Components	46
APPENDIX A: Specifications		47
APPENDIX B: Torque Requirements		49
APPENDIX C: Inspection Checklist		51

1 SAFETY

Failure to follow all safety rules in this manual and the *MLC Construction Pro Series Operator's Manual* and attached to the material lift may result in serious injury or death.

Proper training is strongly recommended before attempting to perform maintenance on any mechanical device.

Before performing maintenance:

- Read, understand and obey all safety rules and instructions in this manual and the *MLC Construction Pro Series Operator's Manual* and attached to the material lift
- Obtain, read and obey all applicable government regulations
- Become familiar with the proper operation of the material lift
- Technicians should receive instruction before performing maintenance on the material lift

MAINTENANCE SAFETY

Follow these safety rules while performing maintenance on the material lift:

ALWAYS tag a damaged material lift and remove it from service until repairs are completed according to manufacturer's specifications.

ALWAYS read, understand and obey the safety rules described in the *MLC Construction Pro Operator's Manual*.

ALWAYS choose a work area that is clean, well lit and properly ventilated.

ALWAYS keep sparks and open flames away from flammable materials such as grease or oil.

ALWAYS verify that cranes, forklifts or other lifting devices, including lifting straps or chains, are rated to support and stabilize the weight of the material lift.

ALWAYS read each procedure carefully before beginning maintenance on the material lift.

ALWAYS wear personal protective equipment (PPE), including protective eyewear, gloves and steel-toed shoes.

ALWAYS be aware of potential hazards created by removing components from the material lift or by lifting or placing loads.

ALWAYS use only tools that are in good working condition. **ALWAYS** use only the correct tools for the maintenance procedure.

2 INSPECTIONS

Regularly inspecting the material lift will ensure that the equipment is operating safely and effectively. Performing all preventive/predictive maintenance procedures according to the manufacturer's recommendations will extend the life of the material lift.

While inspecting the equipment:

- Perform all daily, quarterly and/or annual inspections according to the manufacturer's recommendations.
- Perform all quarterly and/or annual preventive/predictive maintenance procedures according to the manufacturer's recommendations.
- Create a record of all inspections and/or maintenance performed using the *Scheduled Maintenance and Inspection Checklist* at the back of this manual.

DAILY INSPECTIONS

Perform the following inspections daily or before each use of the material lift:

- Verify that the *MLC Construction Pro Series Operator's Manual* is located in the storage container attached to the material lift. The pages must be legible and in good condition.
- Perform a visual inspection of the material lift for wear or damage.
- Perform a function test on the material lift to verify that winch is operating correctly and that the carriage and masts rise in the correct sequence.

VISUAL INSPECTION

Perform the following inspections daily or before each operation:

- Inspect the wheels and casters for excessive wear or damage
- Inspect the material lift for loose, damaged or missing fasteners
- Inspect the base, legs, stabilizers, mast sections, pulleys and forks for damage and improperly installed or missing components
- Inspect the cable for wear, frays, kinks or damage
- Verify that the cable is wrapped around the winch drum at least four times when the carriage is lowered
- Inspect the entire material lift for dents, damage, excessive rust or corrosion and cracks in welds or on structurally critical components, such as mast sections
- Verify that all decals are legible and correctly attached to the material lift

⚠ WARNING

If any worn or damaged components are observed or suspected, remove the material lift from service immediately. Repairs to the material lift should only be performed by authorized personnel according to the manufacturer's specifications.

FUNCTION TEST

Perform the following test daily or before each use to verify that the equipment is not malfunctioning:

- Shift the winch to the slow speed
- Firmly grasp both winch handles
- Rotate the winch handles toward the mast to raise the carriage to its full height

The winch should operate smoothly, without hesitation or binding. The motion should raise the carriage to the top of the first mast section followed in order by each consecutive mast section.

- Rotate the winch handles away from the mast to completely lower the carriage
- Rotate the winch handles one quarter-turn toward the mast - as if raising the carriage - to set the brake

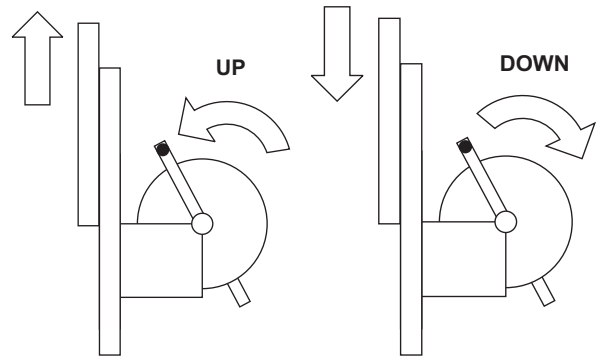

The winch should operate smoothly, without hesitation or binding.

⚠ WARNING

If the equipment malfunctions, remove the material lift from service immediately. Repairs to the material lift should only be performed by authorized personnel according to the manufacturer's specifications.

QUARTERLY INSPECTIONS

Perform the following inspections quarterly or after every 150 hours of operation.

Perform these inspections in addition to all daily inspections:

- Visually inspect the welds for cracks, excessive wear or corrosion. Inspect the welds on the winch mounting plate, loading wheels, Smart-Set adjustment system, base, legs, stabilizers and load lifting attachment(s).
- Clean the mast sections.
- Inspect the winch.
- Lubricate the winch.

CLEANING THE MAST SECTIONS

Perform the following steps to clean the mast sections:

- Raise the material lift to its maximum height
- Visually inspect the inner and outer channels of each mast section for debris or dirt
- Clean the channels of each mast section as needed using a mild cleansing agent

Note: Do not lubricate the mast sections.

NEVER apply an additional side load or horizontal force to a material lift that is loaded or raised.

NEVER place ladders or scaffold against the material lift.

INSPECTING THE WINCH

Perform the following inspections on the winch:

- Inspect the brake lining plates for excessive wear
 - Replace the brake lining plate if it is less than 1/16 inch (1.5 mm) thick
- Inspect the reamed bushings on the shaft for excessive wear
 - Replace the reamed bushing if the wall thickness is less than 1/8 inch (3.1 mm)
- Inspect the winch assembly for loose, damaged or missing fasteners
 - Tighten or replace fasteners as needed
 - Tighten the 3/8-16 lock nut that attaches the reel assembly to 20 ft-lb (27 N*m)
 - Do not over tighten fasteners

LUBRICATING THE WINCH

Lubricate the gears on the following components on the winch using automotive grease:

- The reel assembly
- The ratchet wheel
- The primary shaft assembly
- The intermediate shaft assembly

Lubricate the ratchet pawls with 30W oil.

Lubricate the reel spacer.

ANNUAL INSPECTIONS

Perform the following inspections annually. Perform these inspections in addition to all daily and quarterly inspections:

- Lubricate the casters and wheels.
 - Add lithium-based grease into the bearings of the wheels and casters until it becomes visible at the bearing gap
- Inspect the mast assembly for wear.
- Replace the brake lining plates on the winch.
 - Refer to *Section 5 - Parts* to view an exploded view drawing of the winch
- Visually inspect the painted surfaces of the material lift for blisters, peels, rust, fading or corrosion.

INSPECTING THE MAST ASSEMBLY

Perform the following steps to inspect the mast assembly for wear:

- ❑ Tilt the material lift back and lower it onto a support so that the mast sections are parallel to the ground and the carriage is facing up.
- ❑ At the top of the material lift, measure the clearance between each roller wheel on a mast section and surface of the adjacent mast section.
 - If the clearance between the roller wheel(s) and the adjacent mast section is greater than 0.062 inches (1.57 mm), then replace the roller wheel(s).
 - Refer to *Section 4 - Repair* for instructions to disassemble the mast assembly.
- ❑ At the base of the material lift, measure the clearance between each roller wheel on a mast section and surface of the adjacent mast section.
 - If the clearance between the roller wheel(s) and the adjacent mast section is greater than 0.062 inches (1.57 mm), then replace the roller wheel(s).
 - Refer to *Section 4 - Repair* for instructions to disassemble the mast assembly.

THIS PAGE INTENTIONALLY LEFT BLANK ▶

3 TROUBLESHOOTING

When the material lift malfunctions, use the chart on the following page to determine the cause and to correct the malfunction.

To use the troubleshooting table, locate the specific complaint in the first column. Possible causes of the malfunction are listed in the second column in descending order beginning with the most likely. To correct the problem, perform the procedure listed in the third column, using the information provided in *Section 4 - Repair* and *Section 5 - Parts* as needed.

When troubleshooting the material lift:

- Follow all of the safety rules provided in previous sections of this manual and in the *MLC Construction Pro Series Operator's Manual*
- Use the table on the following page to determine the cause and correction of the malfunction
- Use Sections 4 and 5 of this manual as needed to repair the malfunction

COMPLAINT	Possible CAUSE	CORRECTION
Mast does not sequence properly	The material lift is at or above maximum capacity	Remove excess weight from the load
	The load is not properly centered	Center the load
	Excessive debris on the mast sections or pulleys	Clean the mast sections and pulleys
	The cable is binding on the pulleys	Inspect the pulleys and cable; replace as needed
	The roller wheels are damaged Or The roller wheels are not properly lubricated	Inspect the roller wheels; replace or lubricate as needed
	One or more mast sections is damaged	Inspect the mast sections; replace as needed
Winch operates, but the carriage will not raise	The winch drum is not rotating inside the winch	Inspect the winch; repair or replace as needed
	The cable is damaged or broken	Inspect the cable for frays, kinks or other damage; replace as needed
	One or more pulleys is damaged	Inspect the pulleys; repair or replace as needed
	The cable is not correctly routed through the pulleys	Remove the cable; install the cable, careful to route it correctly through the pulleys
Winch will not operate	The material lift is at or above maximum capacity	Remove excessive weight from the load
	The load is not properly centered	Center the load
	The load is obstructed	Clear the obstruction or reposition the material lift
	The cable is binding at the winch or inside the material lift	Remove the cable; Inspect the cable for frays, kinks or other damage; replace as needed
	The winch is damaged	Inspect the winch; repair or replace the damaged component(s) as needed
	One or more mast sections is damaged	Inspect the mast sections; repair or replace as needed

4 REPAIR

The following section provides instructions for the safe and proper repair of the material lift. It is the responsibility of the technician to follow these instructions. Failure to follow these instructions, as well as all safety rules in this manual and attached to the material lift may result in serious injury or death.

Procedures in this section for disassembling components should be performed only until the necessary repairs can be completed. Follow the steps of the disassembly procedure in reverse order to assemble the material lift.

Only trained and authorized personnel should perform maintenance or repairs on the material lift.

While performing repairs:

- Follow all of the safety rules provided in previous sections of this manual and in the *MLC Construction Pro Series Operator's Manual*
- Follow all instructions provided in this section

REMOVING THE BASE

Follow this procedure to remove the base from the material lift:

- Fully lower the carriage.
- Remove the load lifting attachment from the material lift.
- Remove the cap screws from the stabilizer mounting bracket on the back of the mast.
- Remove the cap screw that attaches each stabilizer to the base.
- Remove the stabilizers.
- Tilt the material lift back and lower it onto a support so that the legs are not touching the ground.
- Remove the retaining pin from each leg.
- Remove the cap screw that attaches each leg to the base.
- Remove the legs.

- Tilt the material lift forward to an upright position.
- Using an overhead hoist, position the material lift onto a support, such as two sawhorses, so that the mast is parallel to the ground and the carriage is facing down.

NOTE: Keep the material lift properly supported during maintenance using an overhead hoist. Failure to support the material lift may cause the equipment to fall.

- Remove the cap screws that attach the mast brace to the base.
- Remove the cap screws on the base.
- Remove the base.

DISASSEMBLING THE MAST

Follow this procedure to disassemble the mast after the base has been removed from the material lift:

- Remove the cap screw that attaches the rope clamp to the reel on the winch assembly.
- Remove the rope clamp from the reel.
- Remove the cable from the reel on the winch assembly.
- Tilt the material lift back and lower it onto a support so that the mast sections are parallel to the ground and the carriage is facing up.
- Remove the cap screw that attaches the cable anchor to the first mast section on the carriage side.
- Pull on the cable anchor to completely remove the cable from the mast.
- Slide the carriage forward along the mast section to expose the down stop block.
- Remove the cap screw that attaches the down stop to the mast section.
- Slide the carriage back and out of the bottom of the mast section.
- After removing the carriage, repeat this procedure to remove each mast section:
 - Slide the mast section forward to expose the down stop block.
 - Remove the cap screw that attaches the down stop to the mast section.
 - Remove the down stop.
 - Slide the mast section back and out of the bottom of the adjacent mast section.

ASSEMBLING THE MAST

Follow this procedure to assemble a mast that has been disassembled:

- Inspect the mast sections including all components and fasteners for wear or damage. Replace as needed.
- Clean the mast sections and rollers using a mild cleansing agent.
- Position the first mast section on a support so that it is parallel to the ground and open side up. Secure the mast section if it is not attached to the base.
- Attach all components including the rollers to the first mast section.
- Slide the second mast section into the first from the bottom until the mast up stop on the second mast section is even with the bottom of the first mast section.
- Repeat the previous step for each mast section. Each mast section should be sticking out slightly from the mast section below. Do not attach the carriage.
- Attach the swaged end of the cable to the cable anchor at the top of the front mast section.
- Feed the other end of the cable through the box section of the carriage and into the pulley.
- Push the cable through the pulley until it comes out the back of the carriage.
- Slide the carriage into the bottom of the front mast section.
- Hold the carriage in place and pull the cable along the length of the front mast section to the top, leaving enough slack to feed the cable into the pulleys.
- Feed the cable into the exposed pulley at the top of the front mast section until it reaches the pulley at the bottom of the front mast section.
- Use needle nose pliers to feed the cable into the pulley at the bottom of the front mast section until it reaches the top of the mast section.
- Feed the cable into the pulley at the top of the next mast section until it reaches the pulley at the bottom of that mast section.
- Repeat this process to feed the cable through the pulleys at the top and bottom of each mast section.
- Slide each mast section forward and attach the mast down stop blocks.
- Attach the cable to the reel by installing the cap screw that fastens the rope clamp to the reel.
- Use the winch to raise all columns to full height and verify that the material lift is operating correctly.

REPLACING A PULLEY

Follow this procedure to replace a lifting pulley without disassembling the mast.

- Fully lower the carriage.
 - Unwind 1 to 2 feet (about 0.5 m) of cable from the winch reel.
 - Tilt the material lift back and lower it onto a support so that the mast is parallel to the ground and the carriage is facing up.
 - If replacing the upper pulley on a mast section, slide the mast section above the pulley to be replaced. If replacing the lower pulley on a mast section, slide the mast section containing the pulley to be replaced.
 - Slide the appropriate mast section forward to expose the mast down stop block.
 - Remove the cap screw that attaches the mast down stop block to the mast section.
 - Remove the down stop block.
 - Slide the appropriate mast section backward until the pulley to be replaced is exposed.
 - Remove the cap screws that attach the pulley assembly to the mast section.
 - Remove the pulley assembly.
 - Remove the cap screw that attaches the pulley to the pulley assembly.
 - Remove the pulley to be replaced.
 - Install the cable into the new pulley.
 - Attach the pulley to the pulley assembly and install the cap screw.
 - Attach the pulley assembly and install the cap screws.
 - Slide the mast section forward.
- Attach the down stop block and install the cap screw.
 - Repeat this procedure as needed for each pulley to be replaced.

ADDITIONAL REPAIRS

Refer to the exploded view drawings in this manual when performing maintenance or repairs on the material lift.

ALWAYS use replacement parts provided or approved by the manufacturer.

5 PARTS

The following section provides exploded view drawings of the major components of the material lift. These drawings are intended to assist maintenance personnel when performing maintenance or repairs on the material lift and when ordering replacement parts.

Only trained and authorized personnel should perform maintenance or repairs on the material lift.

When ordering replacement parts:

- Use the drawings on the following pages to identify the part number, description and quantity of the replacement part(s).
- Call LiftSmart or an authorized LiftSmart dealer to place an order. Be prepared to provide the model and serial number of the material lift as well as a shipping address.
- ALWAYS use only replacement parts provided or authorized by the manufacturer.

NOTE: Slight variations may exist in the design of the MLC Construction Pro Series, contingent upon its date of manufacture. Whenever possible, these variations are noted in the drawings on the following pages. Call LiftSmart or an authorized LiftSmart dealer for more information.

DECALS - ANSI

Part Number	Description	Quantity		
		MLC-12	MLC-18	MLC-24
M00900	Operator's Manual Storage Container	1	1	1
M00901	WARNING - Hazards / NOTICE - Setup	1	1	1
M00905	NOTICE - Two-speed Shift	1	1	1
M00908	Use this Winch Only On The Following:	1	1	1
M00909	WARNING - Crushing Hazard	1	1	1
M00910	WARNING - No Riders	1	1	1
M00911	WARNING - Hazards	1	1	1
M00912	CAUTION - Damaged Machine Hazard	1	1	1
M00918	WARNING - Bodily Injury Hazard, Moving Parts	1	1	1
M00919	DANGER - Electrocution Hazard	2	2	2
M00920	Made in the U.S.A.	1	1	1
M00984	Standard Decal Kit, ANSI/Text (Contains all of the above)		N/A	

Part Number	Description	Quantity		
		MLC-12	MLC-18	MLC-24
M00913	LiftSmart Construction Pro Series (Cosmetic)	2	2	2
M00915	MLC-12 (Cosmetic)	2		
M00916	MLC-18 (Cosmetic)		2	
M00917	MLC-24 (Cosmetic)			2
M00921	NOTICE - Load Capacity, MLC	1	1	1
M01902	Cosmetic Decal Kit, MLC-12	1		
M01903	Cosmetic Decal Kit, MLC-18		1	
M01904	Cosmetic Decal Kit, MLC-24			1

Part Number	Description	Quantity		
		MLC-12	MLC-18	MLC-24
M00966	Serial Plate, Material Lifts	1	1	1

OPTIONAL EQUIPMENT

Part Number	Description
M00902	WARNING - Adjustable Fork Safety (Adjustable forks only)
M00903	NOTICE - Boom Setup (Boom only)
M00904	WARNING - Boom Safety (Boom only)
M00906	WARNING - Bodily Injury Hazard (Lifting platform only)

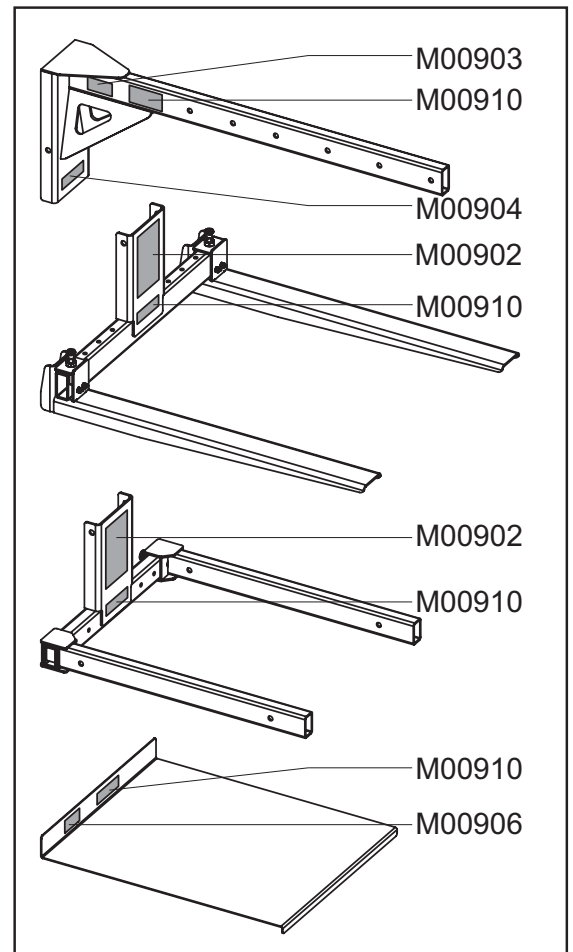
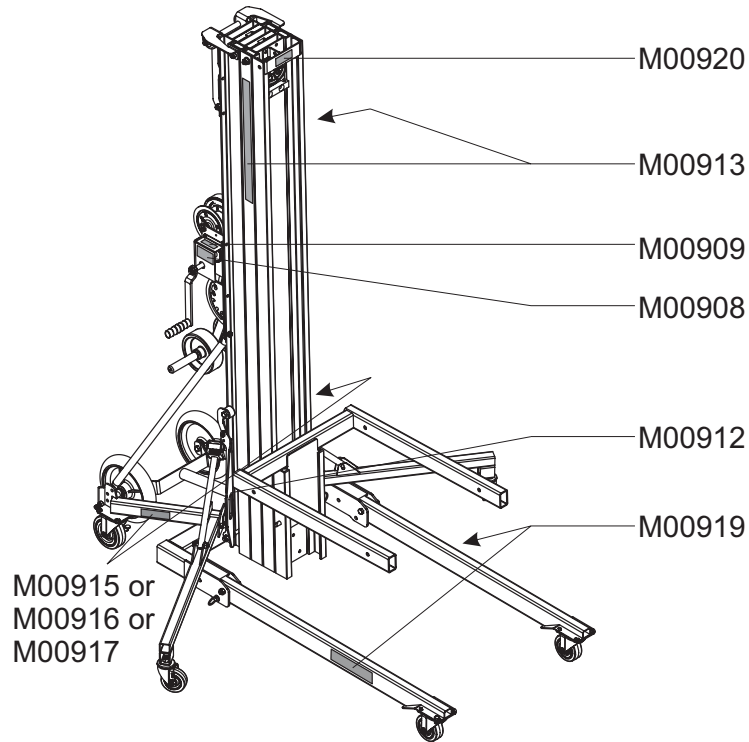

NOTE: The forks are shown in an up/inverted position.

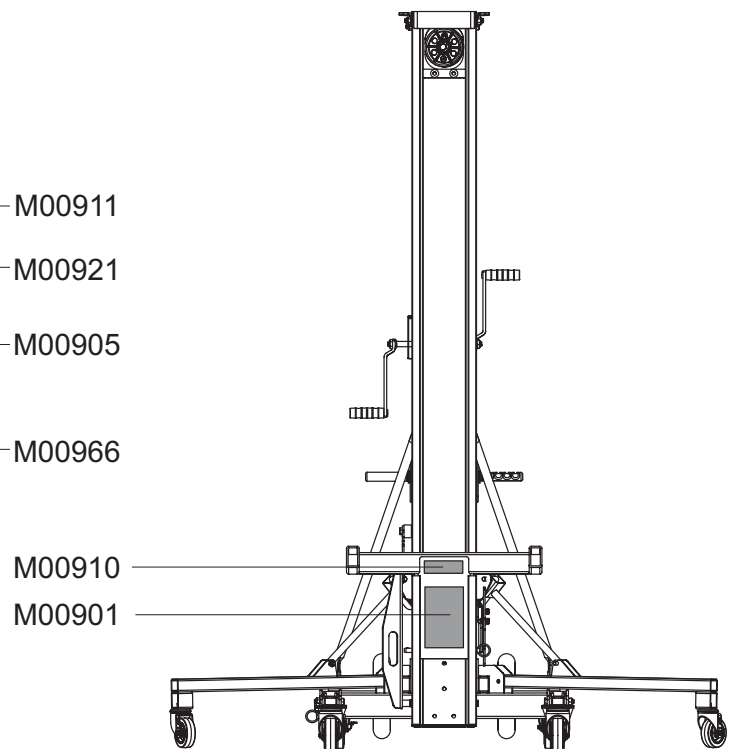
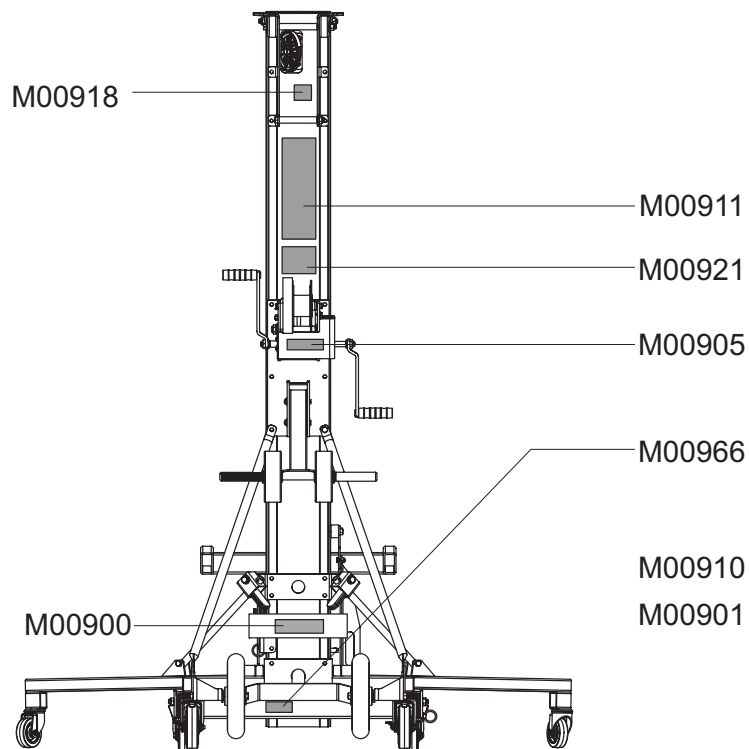

DECALS - CE

Part Number	Description	Quantity		
		MLC-12	MLC-18	MLC-24
M00913	LiftSmart Material Lift Construction Series (Cosmetic)	2	2	2
M00915	MLC-12 (Cosmetic)	2		
M00916	MLC-18 (Cosmetic)		2	
M00917	MLC-24 (Cosmetic)			2
M00920	Made in the U.S.A.	1	1	1
M00950	SYMBOL - Read the Manual	2	2	2
M00951	WARNING - No Riders - SYMBOL	2	2	2
M00952	CAUTION - Moving Parts - SYMBOL	1	1	1
M00953	DANGER - Electrocutation Hazard - SYMBOL	2	2	2
M00954	Use The Winch Only On The Following: - SYMBOL	1	1	1
M00955	WARNING - Load Chart	1	1	1
M00956	WARNING - Brake Lock - SYMBOL	1	1	1
M00957	NOTICE - Two-speed Winch - SYMBOL	1	1	1
M00958	CE Mark	1	1	1
M00966	Serial Plate, Material Lifts	1	1	1
M00986	Decal Kit, MLC, CE/Symbol (Contains all decals listed above excl. M00915A, M00916A and M00917A)		N/A	

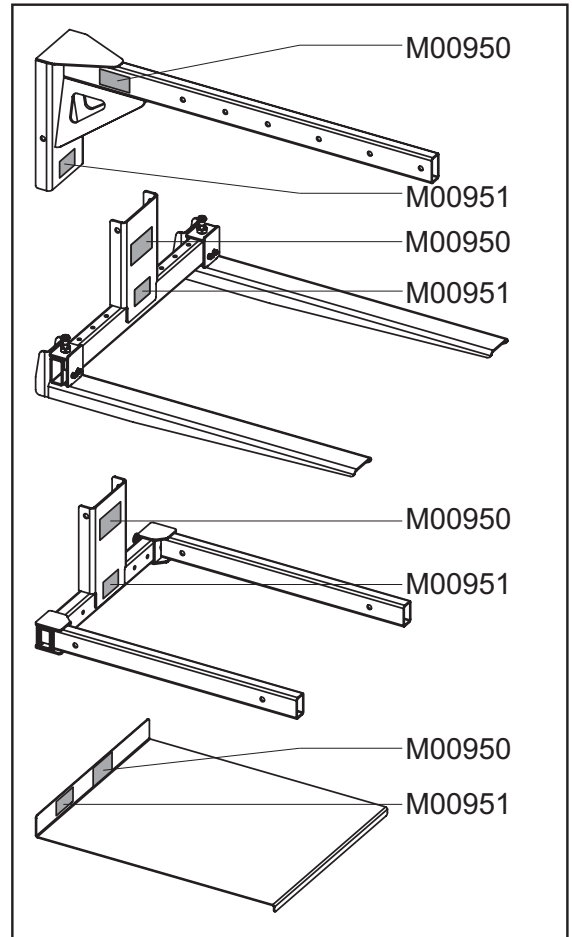
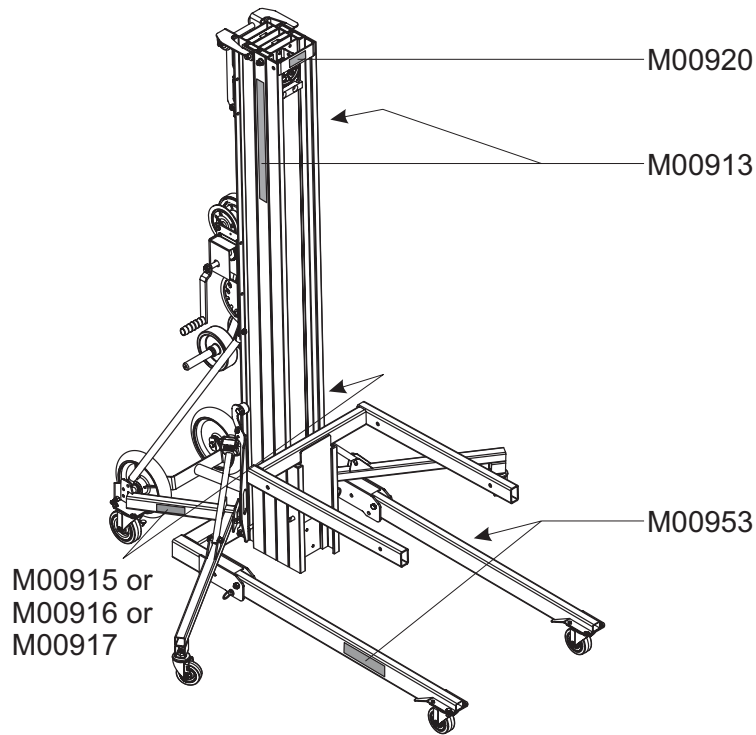

NOTE: The forks are shown in the up/inverted position.

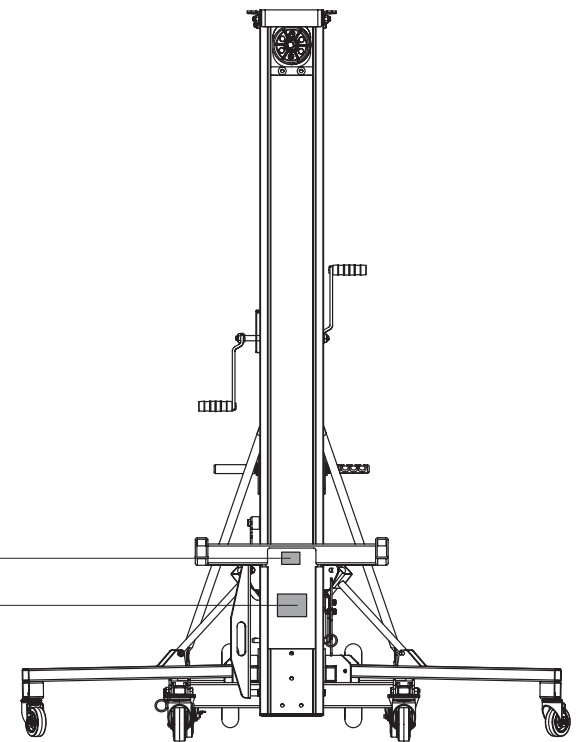
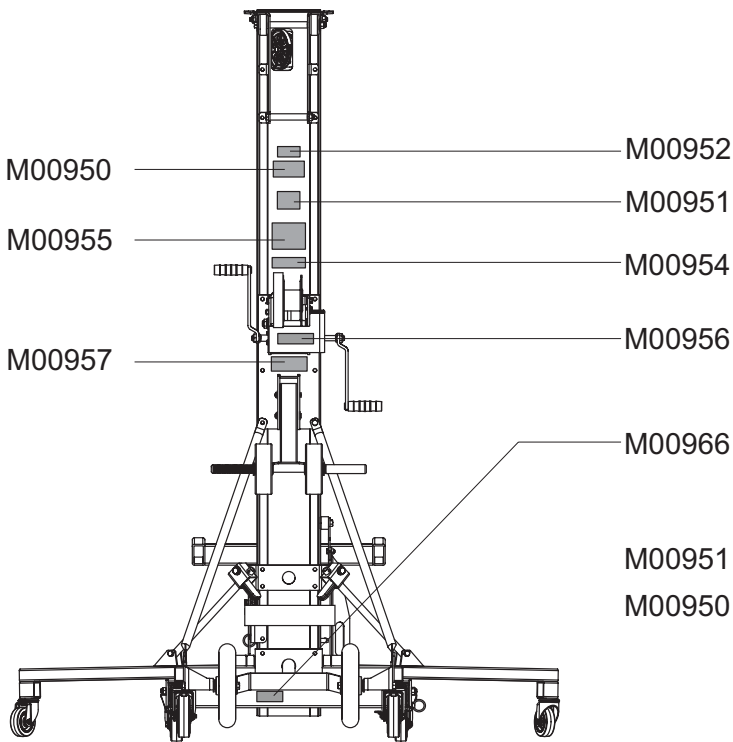

BASE ASSEMBLY

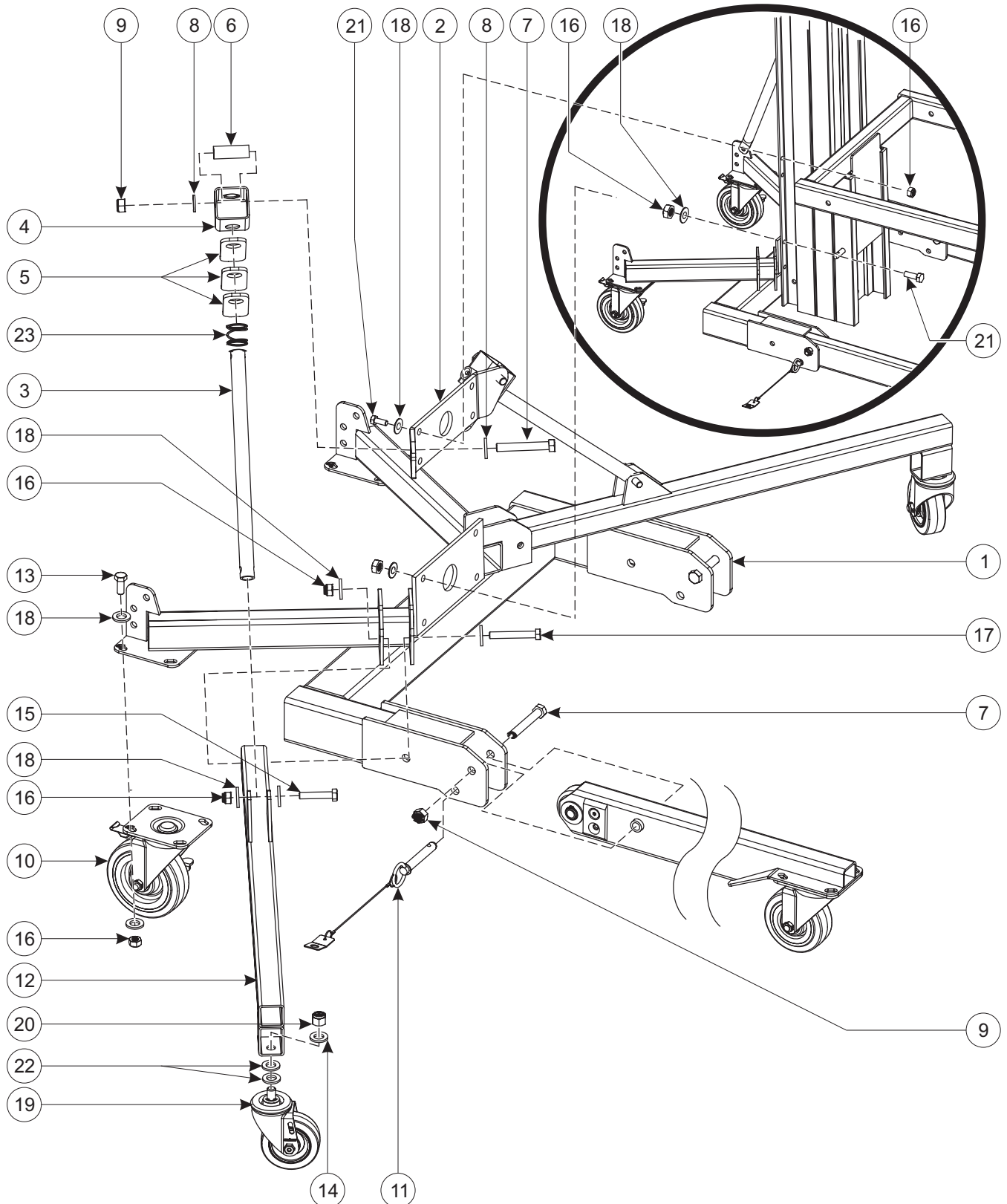

BASE ASSEMBLY

Item Number	Part Number	Description	Quantity		
			MLC-12	MLC-18	MLC-24
1	M00014	Base Weldment	1	1	1
2	M00075	Stabilizer Latch Mounting Plate	1*	1	1
3	M00079	Stabilizer Brace Tube	2*	2	2
4	M00078	Stabilizer Latch Tube	2*	2	2
5	M00077	Stabilizer Latch Plate	6*	6	6
6	M00131	Stabilizer Pivot Tube	2*	2	2
7	M00700	HHCS - M12 x 80	2 + 2*	4	4
8	M00707	Washer - M12	4*	4	4
9	M00701	Hex Nut - M12	2 + 2*	4	4
10	M00034	Caster - 5" x 1 1/2" w/ Brake	2	2	2
11	M00088	Leg Locking Pin w/ Lanyard	2	2	2
12	M00071	Stabilizer Weldment	2*	2	2
13	M00713	HHCS M10 x 25	6	6	6
14	M00750	Lockwasher - 1/2"	2*	2	2
15	M00704	HHCS - M10 x 50	2*	2	2
16	M00706	Hex Nut - M10	10 + 8*	18	18
17	M00705	HHCS - M10 x 70	2*	2	2
18	M00743	Washer - M10	16 + 12*	28	28
19	M00076	Caster 1.5" x 3 1/2" - Stabilizer	2*	2	2
20	M00749	Jam Nut - 1/2-13	2*	2	2
21	M00740	HHCS - M10 x 30	4 + 4*	8	8
22	M00711	Washer - M12 - Fender	4*	4	4
23	M00052	Stabilizer Latch Spring	2*	2	2

***NOTE:** Stabilizers and related components (with quantities denoted above with [*]) are optional on the MLC-12. Verify whether the MLC-12 is equipped with stabilizers before beginning maintenance or ordering replacement parts.

LEG ASSEMBLY (2 LEGS PER MATERIAL LIFT)

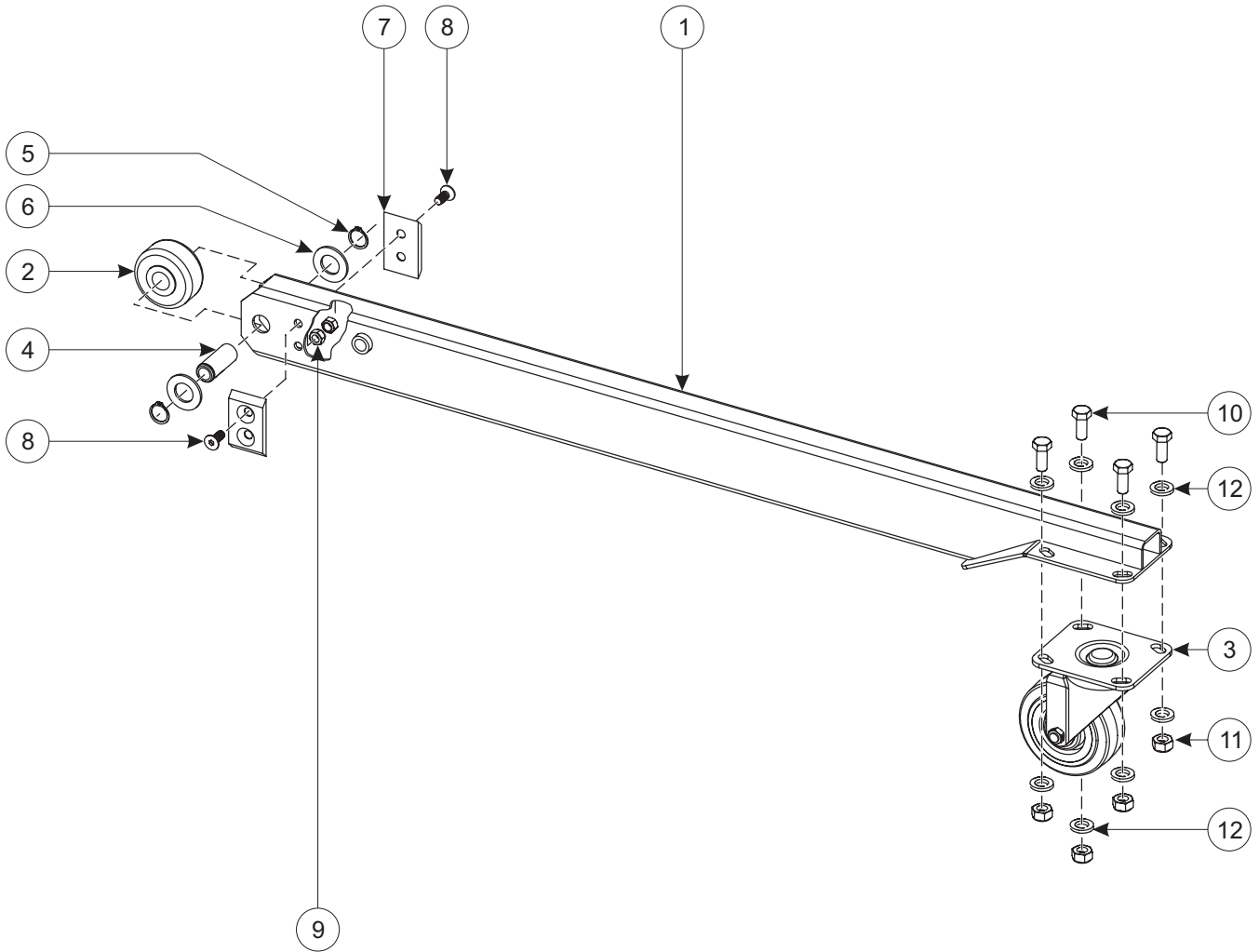

LEG ASSEMBLY

Item Number	Part Number	Description	Quantity		
			MLC-12	MLC-18	MLC-24
1	M00284	Leg Weldment - Short	1	0	0
1	M00027	Leg Weldment - Medium	0	1	0
1	M00280	Leg Weldment - Long	0	0	1
2	M00031	Wheel - 2.5" OD x 0.75" ID	1	1	1
3	M00033	Caster - 4" x 1 1/2" - Leg	1	1	1
4	M00032	Leg Wheel Hub Bushing	1	1	1
5	M00086	Snap Ring - 0.75"	2	2	2
6	M00721	Washer - 0.76" ID x 1.25" OD	2	2	2
7	M00084	Leg Shim	2	2	2
8	M00723	FHCS - M8 x 20	4	4	4
9	M00703	Hex Nut - M8	4	4	4
10	M00713	HHCS - M10 x 25	4	4	4
11	M00706	Hex Nut - M10	4	4	4
12	M00743	Washer - M10	8	8	8

TRANSPORT WHEEL ASSEMBLY

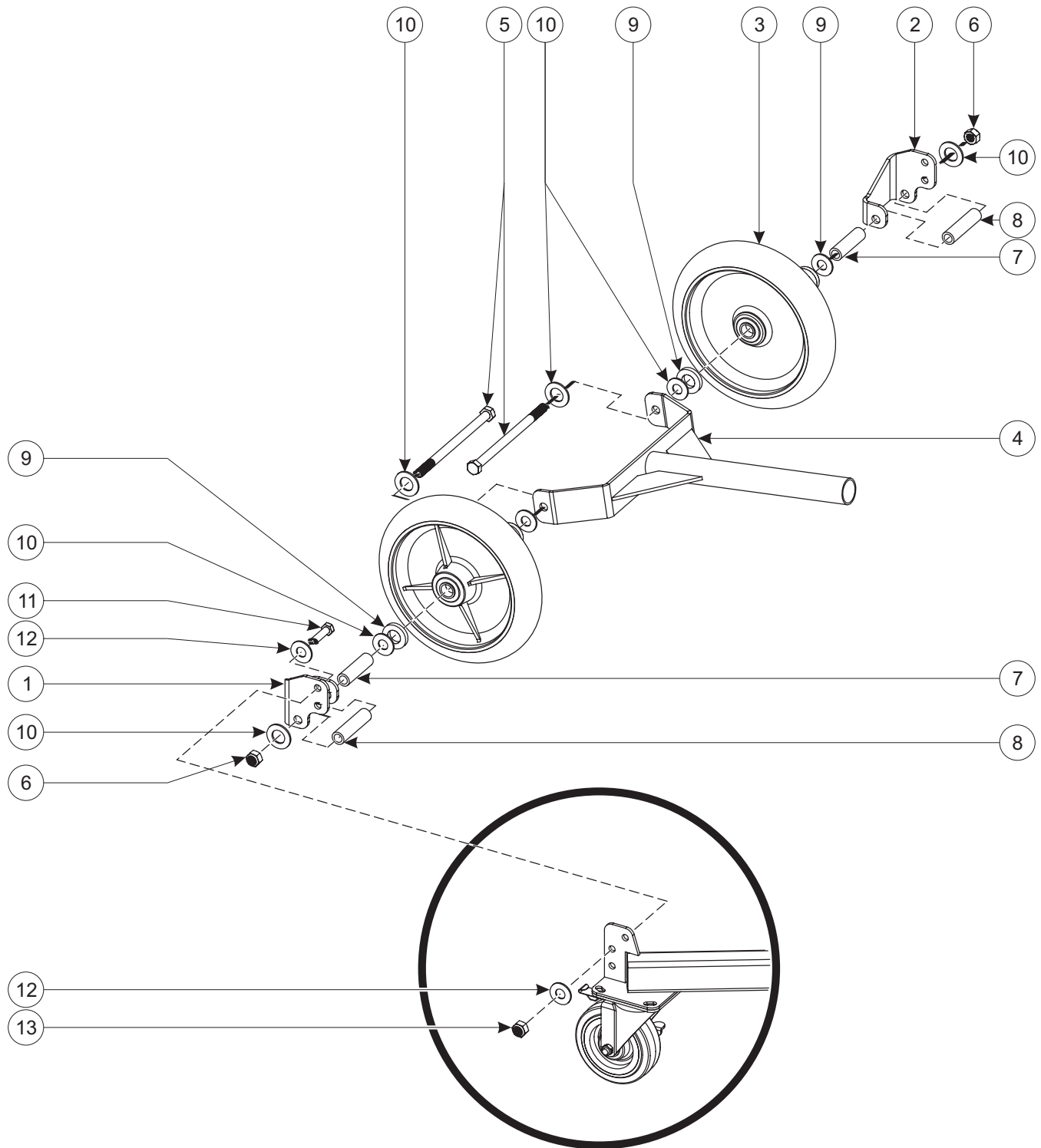

TRANSPORT WHEEL ASSEMBLY

Item Number	Part Number	Description	Quantity		
			MLC-12	MLC-18	MLC-24
1	M00091	Transport Wheel Mounting Bracket - Right	1	1	1
2	M00092	Transport Wheel Mounting Bracket - Left	1	1	1
3	M00095	Transport Wheel - 10" w/ Bushings	2	2	2
4	M00096	Center Mounting Weldment	1	1	1
5	M00727	HHCS - M12 x 190	2	2	2
6	M00701	Hex Nut - M12	2	2	2
7	M00093	Transport Wheel Axle	2	2	2
8	M00094	Aluminum Tube - .75 OD x .5 ID x 3.0	2	2	2
9	M00744	Washer - 3/4" x 1-1/4"	4	4	4
10	M00707	Washer - M12	8	8	8
11	M00740	HHCS - M10 x 30	4	4	4
12	M00743	Washer - M10	8	8	8
13	M00706	Hex Nut - M10	4	4	4

MAST ASSEMBLY (I) - FIRST MAST ASSEMBLY

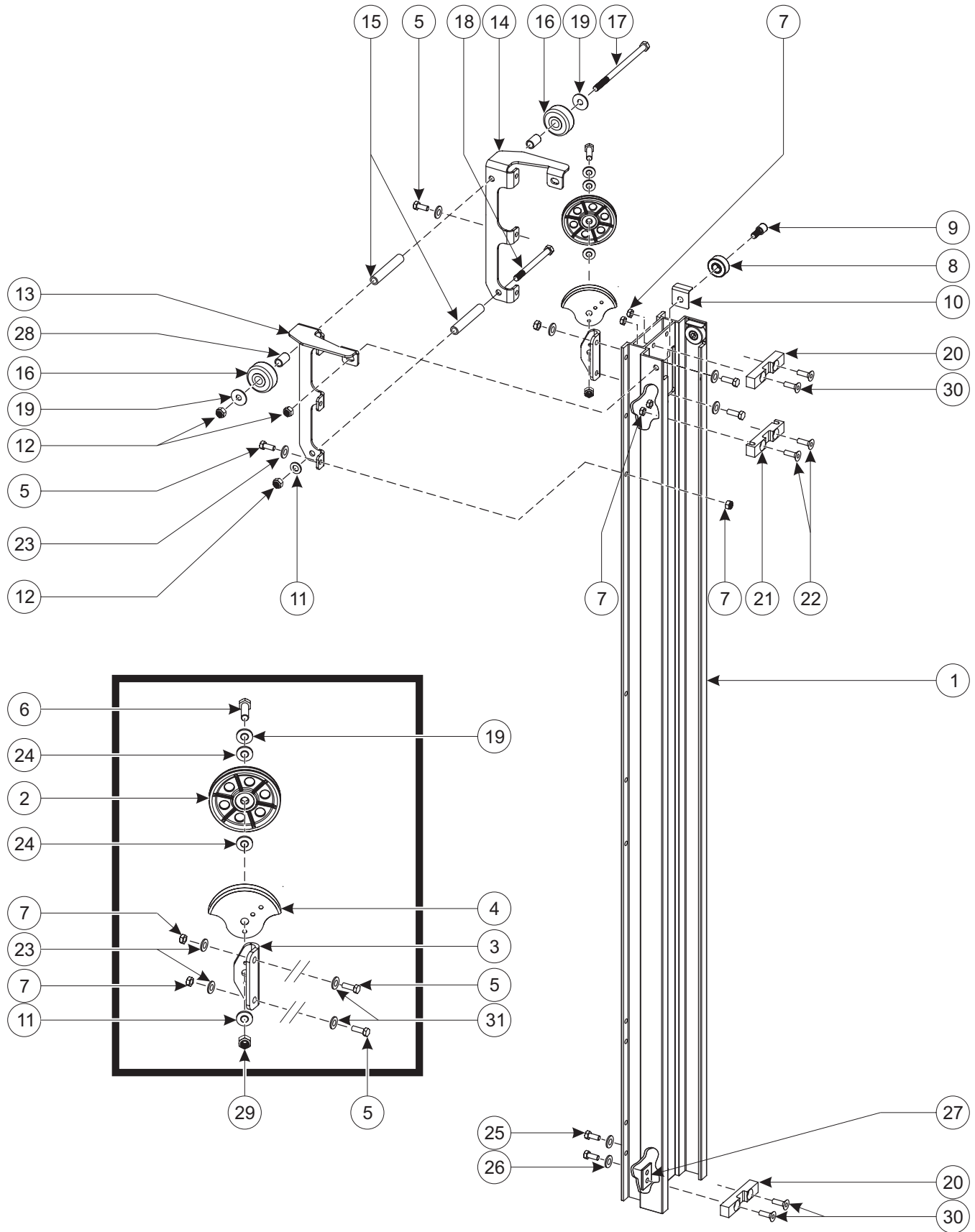

MAST ASSEMBLY (I) - FIRST MAST ASSEMBLY

Item Number	Part Number	Description	Quantity		
			MLC-12	MLC-18	MLC-24
1	M00037	Mast A	1	1	1
2	M00060	Pulley w/ Bearing	1	1	1
3	M00045	Pulley Mount - First Mast	1	1	1
4	M00048	Pulley Guard	1	1	1
5	M00740	HHCS - M10 x 30	8	8	8
6	M00755	HHCS - 1/2-13 x 2" ¹	1	1	1
7	M00706	Hex Nut - M10	12	12	12
8	M00043	Roller	2	2	2
9	M00042	Roller Bolt - SHCS - M12 x 19	2	2	2
10	M00051	Roller Guard	2	2	2
11	M00707	Washer - M12 - Narrow	1	1	1
12	M00701	Hex Nut - M12	4	4	4
13	M00049	Mast Support Bracket - Right	1	1	1
14	M00050	Mast Support Bracket - Left	1	1	1
15	M00211	Aluminum Bushing - .75 OD x .5 ID x 4.45	2	2	2
16	M00031	Wheel - 2.5" OD x 0.75" ID	2	2	2
17	M00712	HHCS - M12 x 210	1	1	1
18	M00720	HHCS - M12 x 140	1	1	1
19	M00711	Washer - M12 - Fender	3	3	3
20	M00062	Down Stop	2	2	2
21	M00061	Up Stop	1	1	1
22	M00756	FHCS - M10 x 35 ²	2	2	2
23	M00743	Washer - M10	8	8	8
24	M00754	Washer - 1/2"- Hardened ³	2	2	2
25	M00740	HHCS - M10 x 30 ⁴	2	2	2
26	M00746	Lockwasher - M10	2	2	2
27	M00058	Reinforcement Block	2	2	2
28	M00210	Axle - For Colson Performa Leg Wheel	2	2	2
29	M00719	Hex Nut - 1/2-13 ⁵	1	1	1
30	M00714	FHCS - M10 x 40	4	4	4
31	M00762	Washer - M10 - Fender	2	2	2

¹ Was HHCS M12 x 40 bolt for 2011 models. Consult factory for update kit when replacing.

² Was FHCS - M10 x 40 for 2011 models.

³ Was different hardened washer for 2011 models (metric sized for M12 bolt and multiple washers used on each pulley assembly). Consult factory for update kit when replacing.

⁴ Was M10 x 20 for 2011 models.

⁵ Was M12 Hex Nut for 2011 models. Consult factory for update kit when replacing.

MAST ASSEMBLY (II) - CENTER MAST ASSEMBLY

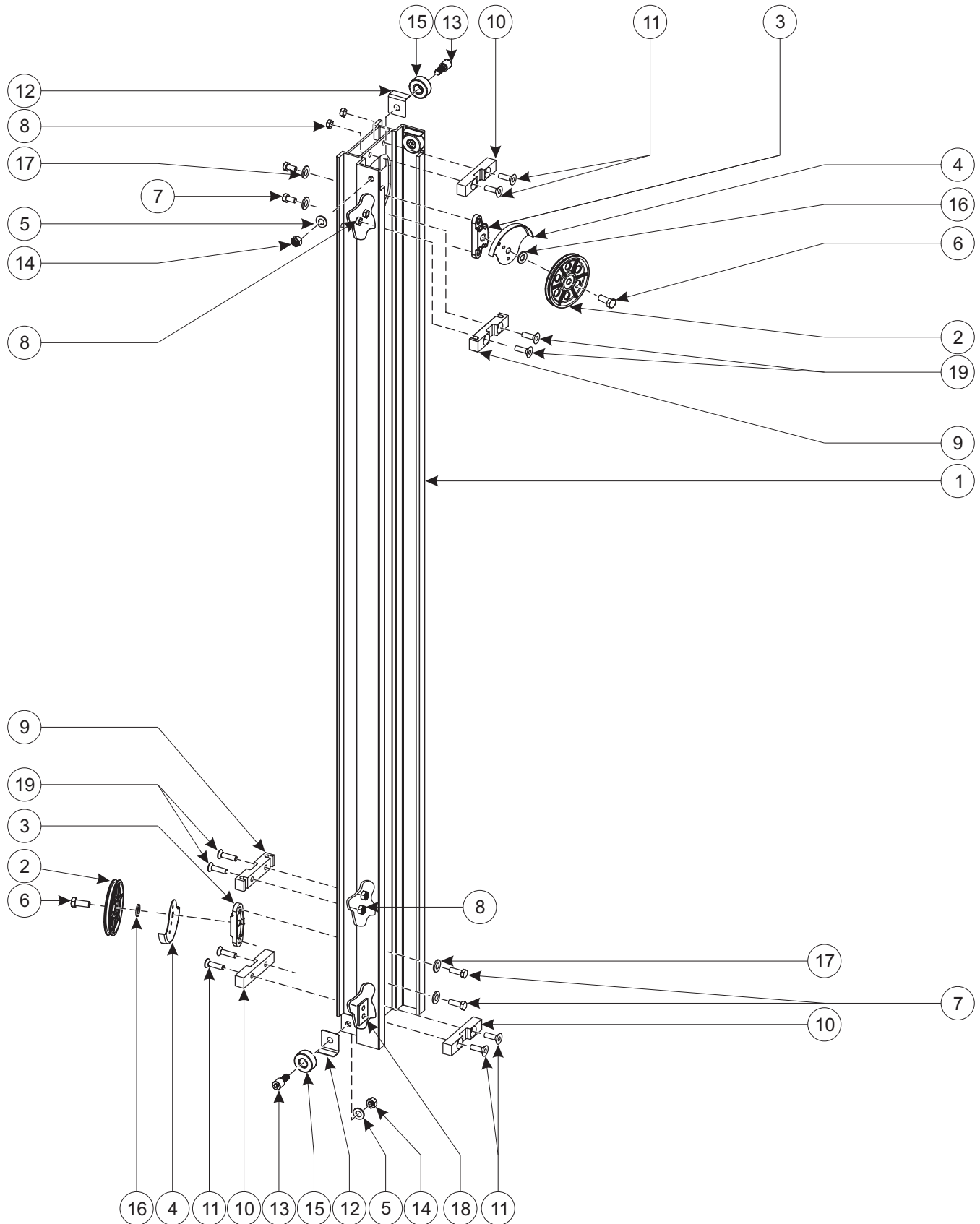

MAST ASSEMBLY (II) - CENTER MAST ASSEMBLY

Item Number	Part Number	Description	Quantity		
			MLC-12	MLC-18	MLC-24
1	M00038	Mast B	0	1	2
2	M00060	Pulley w/ Bearing ¹	0	2	4
3	M00054	Pulley Mount - 1/2-13 Thread ²	0	2	4
4	M00048	Pulley Guard	0	2	4
5	M00707	Washer - M12 - Narrow	0	4	8
6	M00752	HHCS - 1/2-13 x 1 1/4"	0	2	4
7	M00710	HHCS - M10 x 20	0	4	8
8	M00706	Hex Nut - M10	0	6	12
9	M00061	Up Stop	0	2	4
10	M00062	Down Stop	0	3	6
11	M00714	FHCS - M10 x 40	0	6	12
12	M00051	Roller Guard	0	4	8
13	M00042	Roller Bolt - SHCS - M12 x 19, 1/2" Shoulder	0	4	8
14	M00701	Hex Nut - M12	0	4	8
15	M00043	Roller	0	4	8
16	M00754	Washer - 1/2" - Hardened	0	2	4
17	M00746	Lockwasher - M10	0	4	8
18	M00058	Reinforcement Block	0	2	4
19	M00756	FHCS - M10 x 35	0	4	8

¹ When replacing the Pulley (M00060), maintenance personnel should also replace the pulley-mount (M00054 – Pulley Mount - 1/2-13 Thread). Use red Loc-Tite on Item Number 6 and torque to 75 ft*lbs.

² MLC series material lifts, with a serial number before 00157, use an M12 bolt to mount the pulley and a pulley mount that is tapped for metric threads. If this bolt or any portion of the pulley assembly requires replacement (including the pulley mount), replace the entire pulley assembly using service parts kit M00850.

MAST ASSEMBLY (III) - FRONT MAST AND CARRIAGE

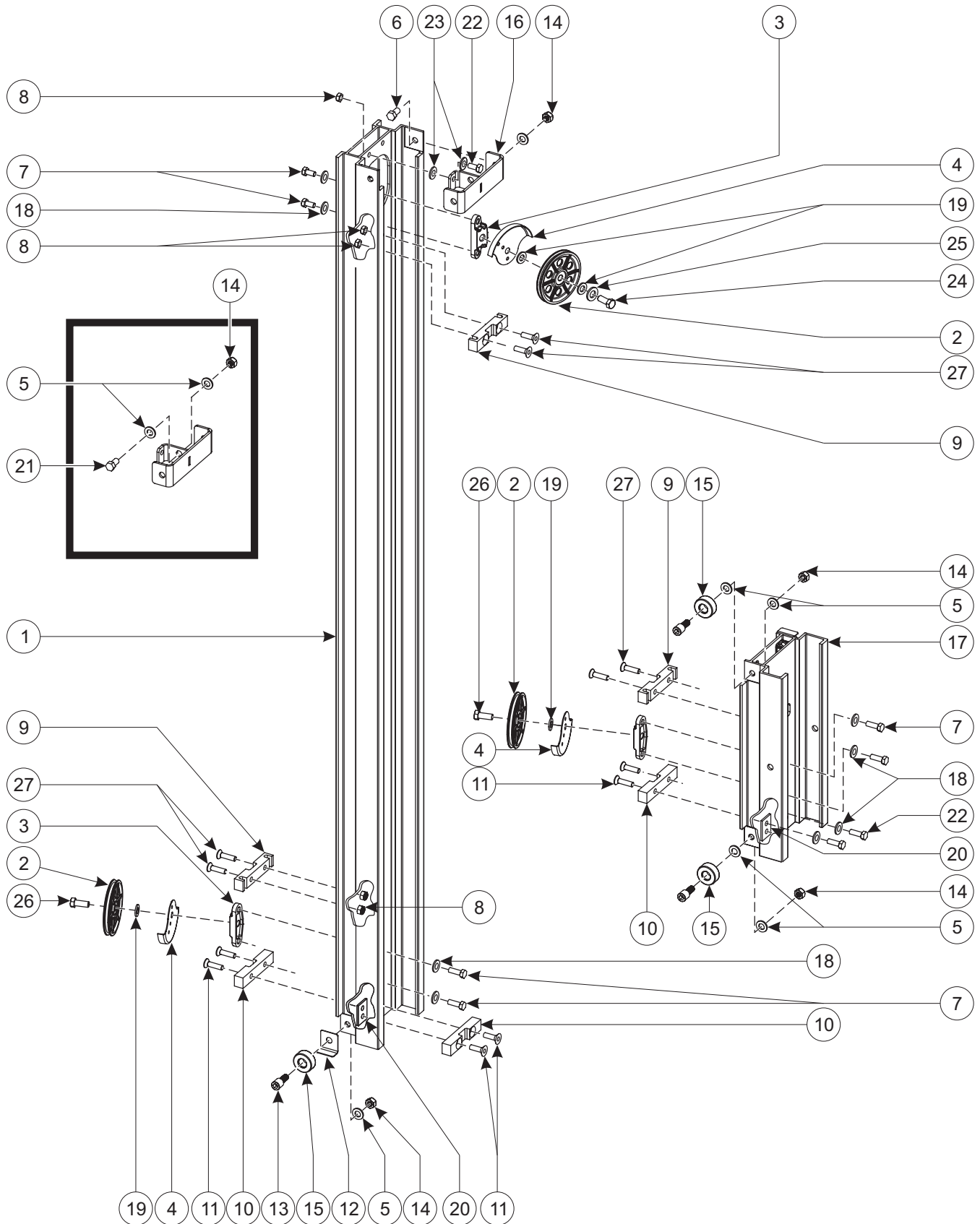

MAST ASSEMBLY (III) - FRONT MAST AND CARRIAGE

Item Number	Part Number	Description	Quantity		
			MLC-12	MLC-18	MLC-24
1	M00038	Mast B	1	1	1
2	M00060	Pulley w/ Bearing ¹	3	3	3
3	M00054	Pulley Mount - 1/2-13 Thread ²	3	3	3
4	M00048	Pulley Guard	3	3	3
5	M00707	Washer - M12 - Narrow	14	14	14
6	M00716	HHCS - M12 x 30	2	2	2
7	M00710	HHCS - M10 x 20	6	6	6
8	M00706	Hex Nut - M10	7	7	7
9	M00061	Up Stop	3	3	3
10	M00062	Down Stop	3	3	3
11	M00714	FHCS - M10 x 40	6	6	6
12	M00051	Roller Guard ³	2	2	2
13	M00042	Roller Bolt - SHCS - M12 x 19, 1/2" Shoulder	6	6	6
14	M00701	Hex Nut - M12	9	9	9
15	M00043	Roller	6	6	6
16	M00065	Cable End Weldment	1	1	1
17	M00040	Carriage	1	1	1
18	M00746	Lockwasher - M10	8	8	8
19	M00754	Washer - 1/2" - Hardened	4	4	4
20	M00058	Reinforcement Block	4	4	4
21	M00715	HHCS - M12 x 40	1	1	1
22	M00740	HHCS - M10 x 30	3	3	3
23	M00743	Washer - M10 - Flat	2	2	2
24	M00753	HHCS - 1/2-13 x 1 1/2"	1	1	1
25	M00711	Washer - M12 Fender	1	1	1
26	M00752	HHCS - 1/2-13 x 1 1/4"	2	2	2
27	M00756	FHCS - M10 x 35	6	6	6

¹ When replacing the Pulley (M00060), maintenance personnel should also replace the pulley-mount (M00054 – Pulley Mount - 1/2-13 Thread). Use red Loc-Tite on Item Number 6 and torque to 75 ft*lbs.

² MLC series material lifts, with a serial number before 00157, use an M12 bolt to mount the pulley and a pulley mount that is tapped for metric threads. If this bolt or any portion of the pulley assembly requires replacement (including the pulley mount), replace the entire pulley assembly using service parts kit M00850.

³ Roller guards were used with the carriage roller wheels on early production versions of the MLC.

BACK OF THE MAST ASSEMBLY

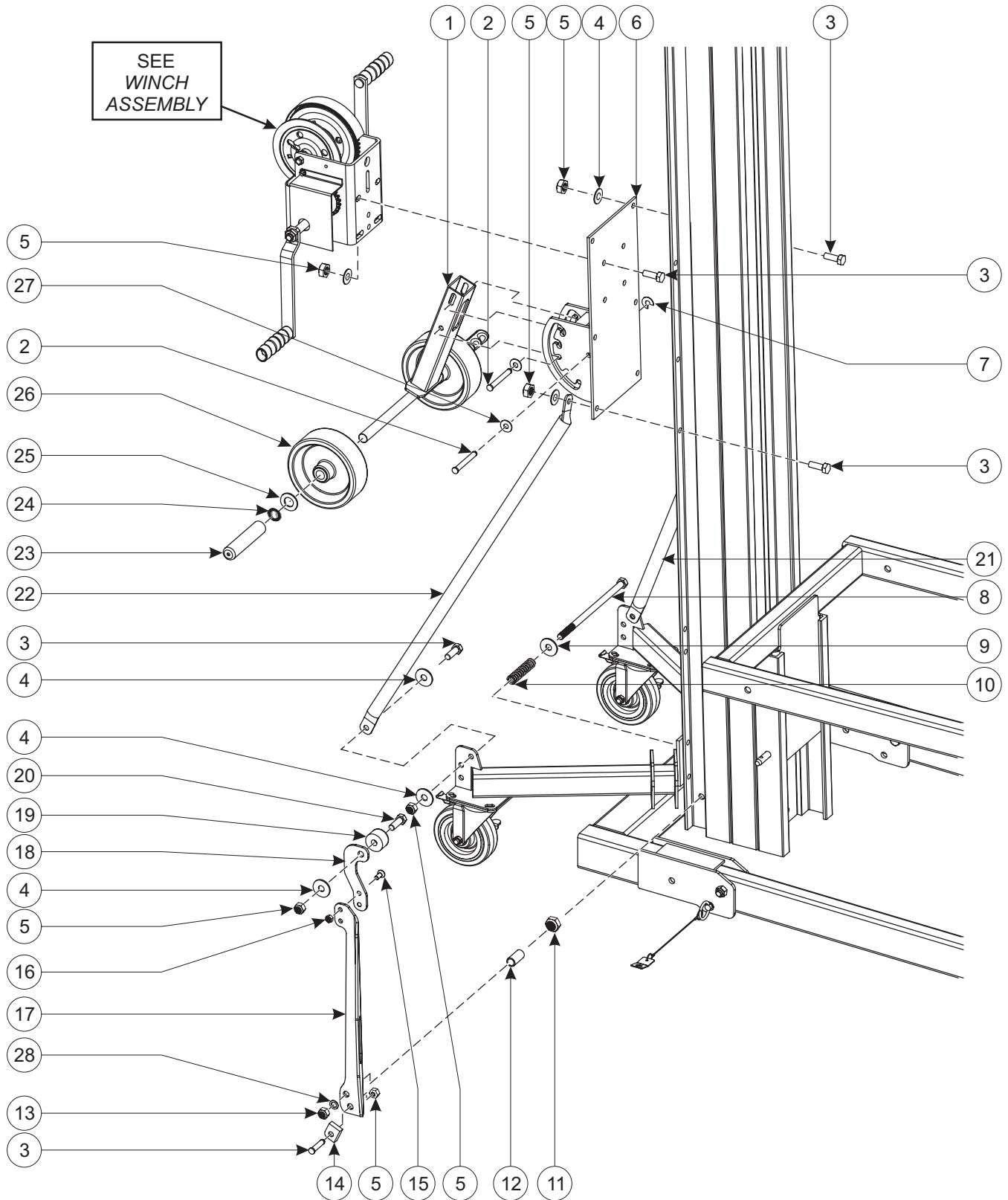

BACK OF THE MAST ASSEMBLY

Item Number	Part Number	Description	Quantity		
			MLC-12	MLC-18	MLC-24
1	M00106	Push Tube Weldment	1	1	1
2	M00112	Pin - Clevis - 3/8" x 3"	2	2	2
3	M00740	HHCS - M10 x 30	13	13	13
4	M00743	Washer - M10	15	15	15
5	M00706	Hex Nut - M10	14	14	14
6	M00101	Winch Mount Weldment	1	1	1
7	M00118	E-Ring - 3/8"	2	2	2
8	M00717	HHCS - M12 x 240	1	1	1
9	M00711	Washer - M12 - Fender	1	1	1
10	M00124	Spring, Hold-Down	1	1	1
11	M00724	Jam Nut, Hexagonal - M12	1	1	1
12	M00125	Tube, Aluminum - 0.5" ID x 0.75" OD x 0.875"	1	1	1
13	M00701	Hex Nut - M12	1	1	1
14	M00123	Hold Down Stop	1	1	1
15	M00723	FHCS - M8 x 20	2	2	2
16	M00703	Hex Nut - M8	2	2	2
17	M00121	Hold Down Bar	1	1	1
18	M00126	Hold Down End Hook	1	1	0
18	M00133	Hold Down End Hook, Medium	0	0	1
19	M00122	Hold Down End	1	1	1
20	M00756	HHCS - M10 x 35	1	1	1
21	M00024	Strut - Left	1	1	1
22	M00025	Strut - Right	1	1	1
23	M00110	Grip Handle	2	2	2
24	M00119	Push Nut - 0.75"	2	2	2
25	M00744	Washer - 0.76" ID x 1.25" OD	4	4	4
26	M00111	Wheel - 6" x 2" x 0.75"	2	2	2
27	M00709	Washer - 0.4" ID x 1.0 OD x 0.05" - Nylon	6	6	6
28	M00707	Washer - M12 - Narrow	1	1	1

WINCH ASSEMBLY

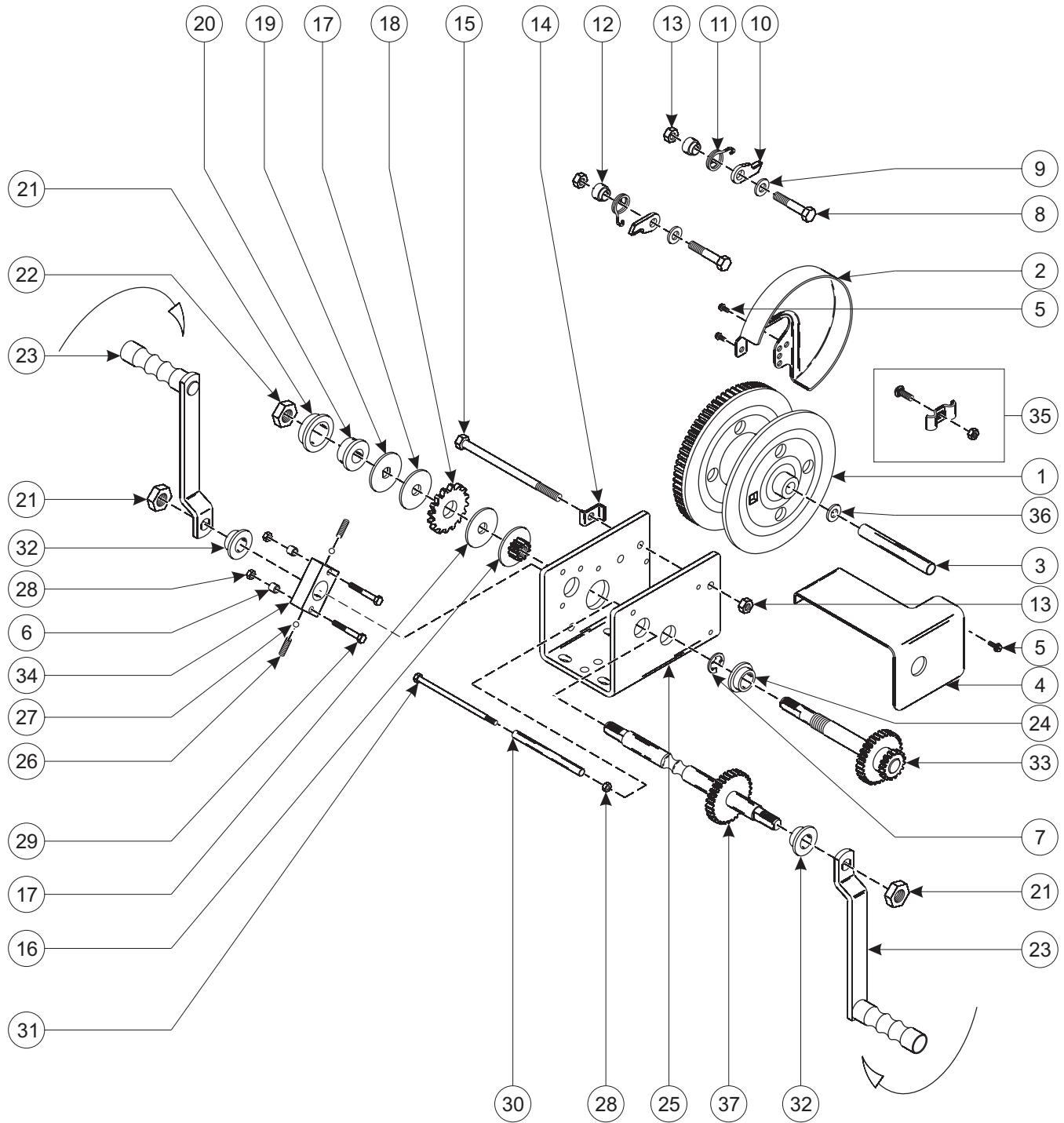

WINCH ASSEMBLY

Item Number	Part Number	Description	Quantity		
			MLC-12	MLC-18	MLC-24
1	M00800	Reel Assembly	1	1	1
2	M00801	Reel Cover	1	1	1
3	M00802	Reel Spacer	1	1	1
4	M00803	Gear Cover	1	1	1
5	M00804	Thread Forming Screw - 1/2"	1	1	1
6	M00805	Brake Spring Spacer	2	2	2
7	M00806	E-Ring - 3/4"	1	1	1
8	M00807	HHCS - 3/8-16 x 1 1/2	2	2	2
9	M00808	Washer - Flat - 3/8"	2	2	2
10	M00809	Ratchet Pawl Assembly	2	2	2
11	M00810	Ratchet Spring	2	2	2
12	M00811	Ratchet Spacer	2	2	2
13	M00812	Hex Nut 3/8-16	3	3	3
14	M00813	Reel Bolt Lock	1	1	1
15	M00814	HHCS - 3/8-16 x 5 1/2	1	1	1
16	M00815	Brake Hub Assembly	1	1	1
17	M00816	Break Lining Plate	2	2	2
18	M00817	Ratchet Wheel	1	1	1
19	M00818	Washer - Double D	1	1	1
20	M00819	Spacer	2	2	2
21	M00820	Sintered Iron Bearing	1	1	1
22	M00821	Hex Nut - 5/8-11	3	3	3
23	M00822	8" Offset Handle Assembly	0	2	2
24	M00823	Sintered Iron Bearing - 3/4"	1	1	1
25	M00824	Base	1	1	1
26	M00825	Detent Spring	2	2	2
27	M00826	Chrome Ball	2	2	2
28	M00827	Hex Nut - 1/4-20	3	3	3
29	M00828	HHCS - 1/4-20 x 1 1/2	2	2	2
30	M00829	Base Spacer 3/8 x 4 3/8	1	1	1
31	M00830	HHCS - 1/4-20 x 5 1/4	1	1	1
32	M00831	Reamed Bushing	2	2	2
33	M00832	Intermediate Shaft Assembly	1	1	1
34	M00833	Detent Block	1	1	1
35	M00834	Rope Clamp Assembly	1	1	1
36	M00835	Washer - Flat - 15/16	1	1	1
37	M00836	Primary Shaft Assembly	1	1	1
38	M00837	6" Offset Handle Assembly	2	0	0

ADJUSTABLE FORKS ASSEMBLY

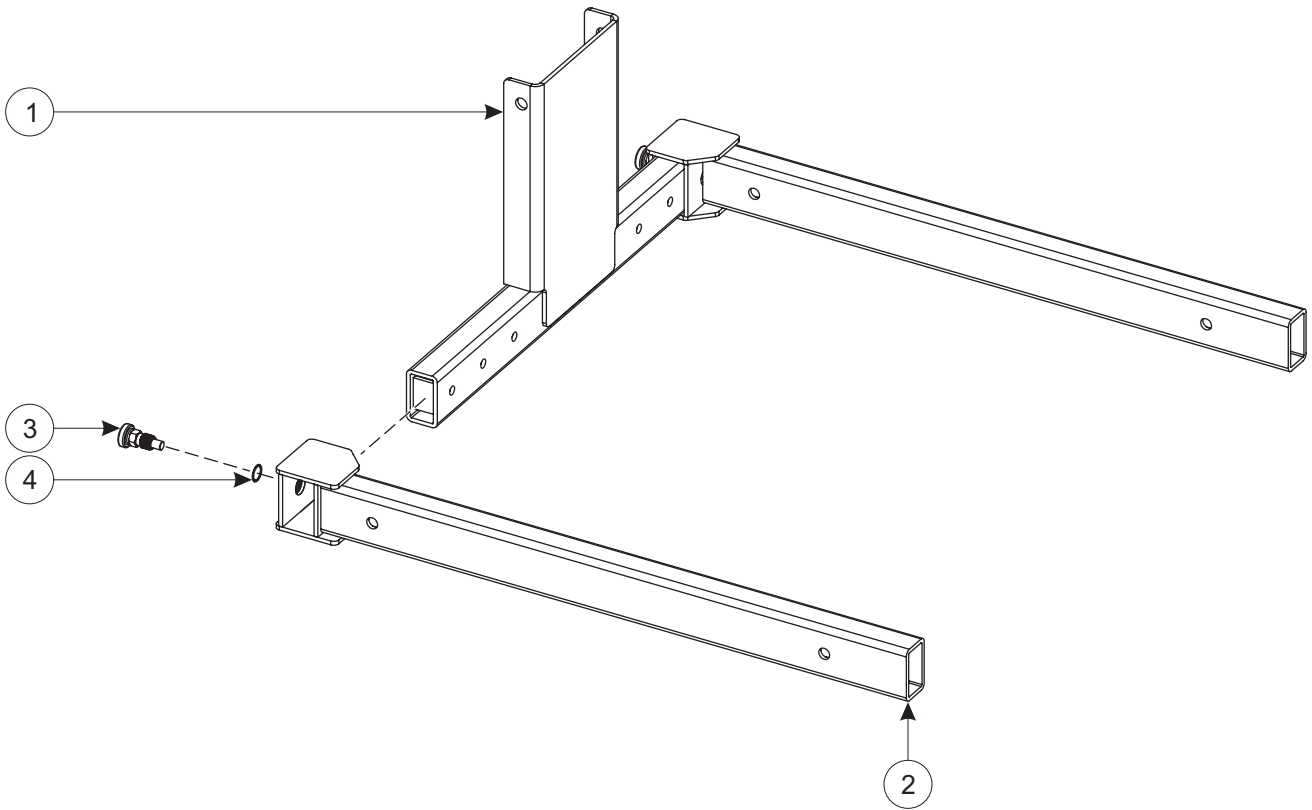

ADJUSTABLE FORKS ASSEMBLY

Item Number	Part Number	Description	Quantity		
			MLC-12	MLC-18	MLC-24
1	M00191	Fork Adjustment Weldment	1	1	1
2	M00196	Adjustable Fork	2	2	2
3	M00261	Snap Pin	2	2	2
4	M00737	Fiber Washer - .625" x 0.75"	2	2	2

FLAT FORKS ASSEMBLY

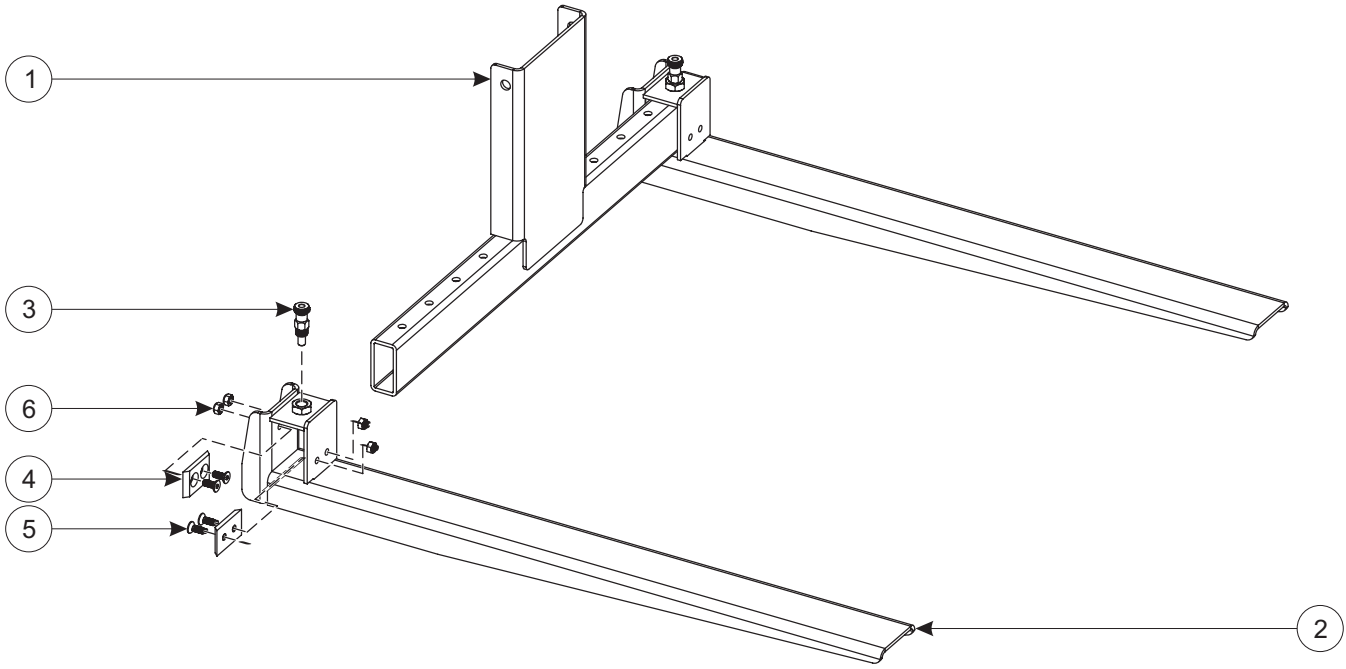

FLAT FORKS ASSEMBLY

Item Number	Part Number	Description	Quantity		
			MLC-12	MLC-18	MLC-24
1	M00251	Flat Fork Main Weldment	1	1	1
2	M00255	Flat Fork Weldment	2	2	2
3	M00261	Snap Pin	2	2	2
4	M00262	Flat Fork Shim	4	4	4
5	M00723	FHCS - M8 x 20	4	4	4
6	M00703	Hex Nut - M8	4	4	4

BOOM ASSEMBLY / PLATFORM ASSEMBLY

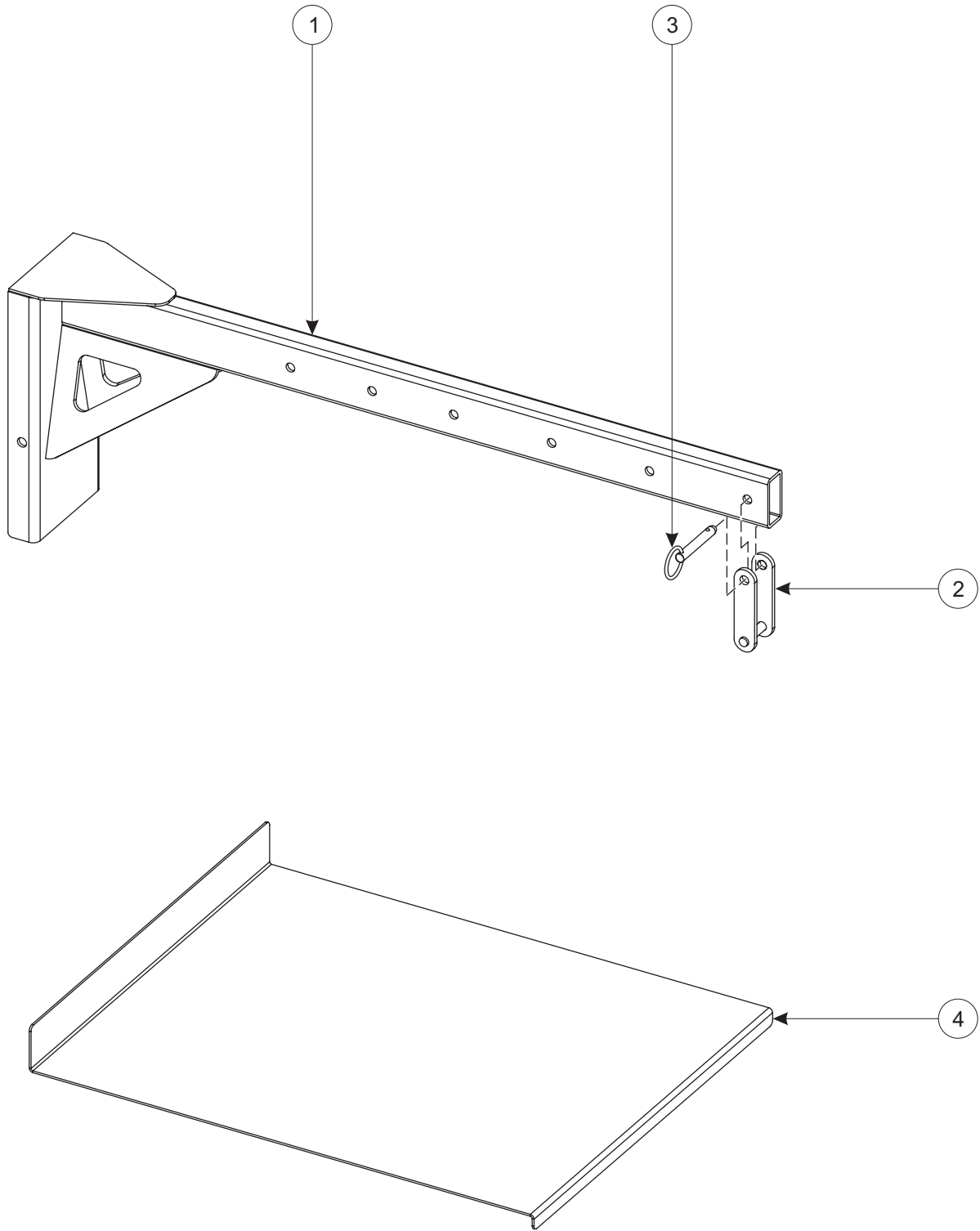

BOOM ASSEMBLY

Item Number	Part Number	Description	Quantity		
			MLC-12	MLC-18	MLC-24
1	M00164	Boom Weldment	1	1	1
1	M00200	Clevis Weldment	1	1	1
3	M00088	Locking Pin	1	1	1

PLATFORM ASSEMBLY

Item Number	Part Number	Description	Quantity		
			MLC-12	MLC-18	MLC-24
4	M00160	Platform Weldment	1	1	1

PIPE CRADLE ASSEMBLY / FORK EXTENSION ASSEMBLY

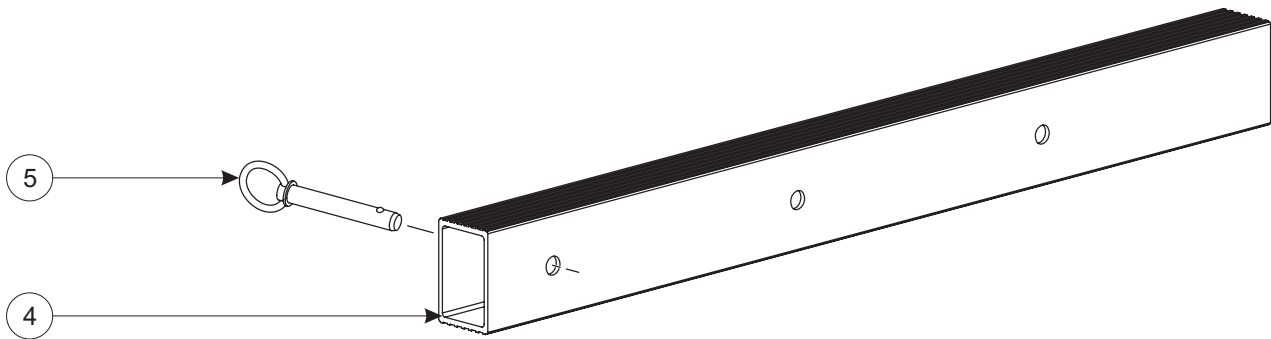
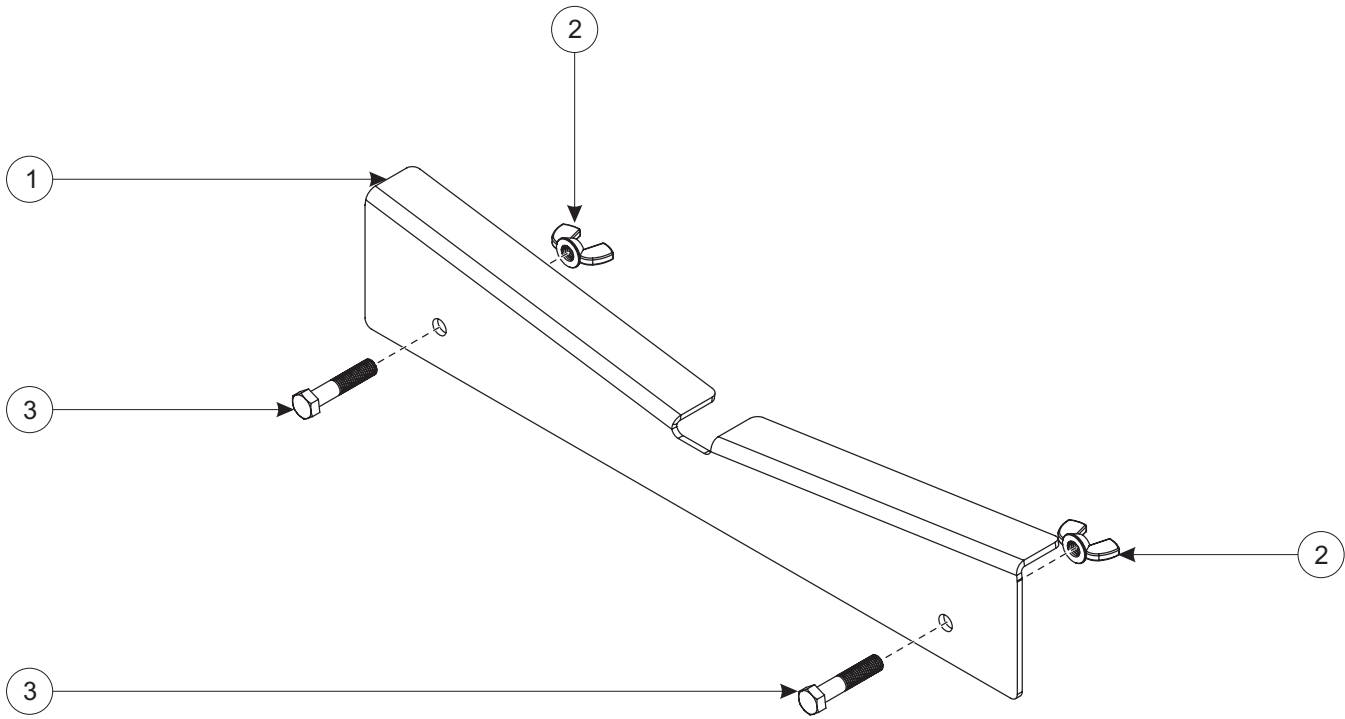

PIPE CRADLE ASSEMBLY

Item Number	Part Number	Description	Quantity		
			MLC-12	MLC-18	MLC-24
1	M00271	Pipe Cradle	1	1	1
2	M00730	Wing Nut - M12	2	2	2
3	M00731	HHCS - M12 x 60	2	2	2

FORK EXTENSION ASSEMBLY

Item Number	Part Number	Description	Quantity		
			MLC-12	MLC-18	MLC-24
4	M00163	Fork Extension Tube	1	1	1
5	M00088	Pin - Detent - 0.5" x 2.5"	1	1	1

ADDITIONAL COMPONENTS (NOT SHOWN ON DRAWINGS)

Item Number	Part Number	Description	Quantity		
			MLC-12	MLC-18	MLC-24
	M00128	Cable, 3/16" - 7 x 19 - Galvanized		Length Varies	
	M00129	Cable Thimble - 3/16"	1	1	1
	M00130	Cable Swage - 3/16"	1	1	1
	M00186	Manual Storage Tube	1	1	1
	M00187	Manual Storage Tube Cap	2	2	2
	M00188	Clamp - Manual Storage Tube	2	2	2
	M00747	HHCS - M6 x 25	2	2	2
	M00748	Hex Nut - M6	2	2	2
	M00282	Cable Assembly, MLC-12 (incl. M00128, M00129, M00130)	1	0	0
	M00127	Cable Assembly, MLC-18 (incl. M00128, M00129, M00130)	0	1	0
	M00286	Cable Assembly, MLC-24 (incl. M00128, M00129, M00130)	0	0	1

THIS PAGE INTENTIONALLY LEFT BLANK ▶

APPENDIX A: SPECIFICATIONS

SPECIFICATIONS

LiftSmart is dedicated to the continuous improvement of this and all LiftSmart products. Specifications are subject to change without notice.

	MLC-12	MLC-18	MLC-24
Lift Height			
Standard forks - up	13 ft 3 in 4 m	18 ft 6 in 5.6 m	24 ft 4 in 7.4 m
Standard forks - down	11 ft 6 in 3.5 m	16 ft 10 in 5.1 m	22 ft 7 in 6.9 m
Adjustable forks - up	13 ft 3 in 4 m	18 ft 6 in 5.6 m	24 ft 4 in 7.4 m
Adjustable forks - down	11 ft 6 in 3.5 m	16 ft 10 in 5.1 m	22 ft 7 in 6.9 m
Boom	12 ft 6 in 3.8 m	17 ft 10 in 5.4 m	23 ft 7 in 7.2 m
Height - stowed	7 ft 3 in 2.2 m		
Length - stowed	2 ft 10 in 85 cm		
Length - operating	5 ft 2 in 1.6 m	6 ft 1 in 1.9 m	6 ft 9 in 2.1 m
Width - stowed	30.5 in 77 cm		
Width - stabilizers deployed	5 ft 4 in 1.6 m		
Stabilizers	Optional	Standard	
Forks - Length	30 in 76 cm		
Forks - Width - outside	23 in 58 cm		
Maximum load capacity			
14 in (36 cm) load center	750 lb 340 kg	700 lb 318 kg	650 lb 295 kg
24 in (61 cm) load center	450 lb 205 kg	440 lb 200 kg	430 lb 195 kg
42 in (107 cm) load center	200 lb 91 kg	185 lb 84 kg	175 lb 80 kg
Ground clearance	2.5 in 6 cm		
Load height - minimum	6 in 15 cm		
Weight	234 lb 106 kg	320 lb 145 kg	365 lb 166 kg
Winch cranks/distance			
High speed	4 cranks/ft 13.1 cranks/m		
Low speed	15 cranks/ft 49.2 cranks/m		

APPENDIX B: TORQUE REQUIREMENTS

Bolt Size	Threads	Dry Torque - SAE Grade 5 Bolts			Dry Torque - SAE Grade 8 Bolts		
		in*lb	ft*lb	N*m	in*lb	ft*lb	N*m
10	24	43		5	60		7
1/4	20	96		11	144		16
5/16	18		17	23		25	34
3/8	16		30	41		45	61
7/16	14		50	68		70	95
1/2	13		75	102		110	149
9/16	12		110	149		150	204
5/8	11		150	204		220	298
3/4	10		260	353		380	515
7/8	9		430	583		600	814
1	8		640	868		900	1221

Bolt Size (Metric)	Recommended Torque (N*m)		Recommended Torque (in*lbs)		Recommended Torque (ft*lbs)	
	Class 8.8	Class 10.9	Class 8.8	Class 10.9	Class 8.8	Class 10.9
	5	7	9	62	80	5
6	12	16	106	142	9	12
8	30	40	266	354	22	30
10	55	75	487	664	41	55
12	100	135	885	1195	74	100
14	160	215	1416	1903	118	159
16	245	335	2168	2965	181	247
20	480	650	4248	5753	354	479

NOTE: The specifications listed above are for general use only. Torque specifications on the material lift may vary. Specifications described for a specific procedure supersede the specifications listed above.

NOTE: The specifications listed above are for dry bolts. Torque specifications for a lubricated bolt are generally 25% less than the specification listed above.

APPENDIX C: INSPECTION CHECKLIST

Scheduled Maintenance and Inspection Checklist

Use the checklist on the following page to create a record of all scheduled inspections and/or maintenance that is performed on the material lift.

Make copies of the checklist as needed and keep a permanent record of all inspections and maintenance performed on the material lift.

Mark the appropriate box to indicate whether a daily, quarterly or annual inspection is being performed.

When performing a quarterly inspection, also perform a daily inspection.

When performing an annual inspection, always perform a quarterly inspection and a daily inspection.

Mark the appropriate box beside each inspection procedure: A for acceptable or U for unacceptable.

If U (Unacceptable) is marked for any inspection procedure, tag the material lift and remove it from service until repairs are completed according to manufacturer's specifications.

After making repairs to a damaged material lift, ALWAYS perform a new full inspection before returning the material lift to service.

Only authorized and trained personnel should perform maintenance on the material lift.

Scheduled Maintenance and Inspection Checklist

Model

Serial Number

Inspection Location

Inspector Name (Print)

Inspector Title

Inspector Signature

Date

Mark the appropriate box to indicate whether a daily, quarterly or annual inspection is being performed.

Daily Inspection

Quarterly Inspection

Annual Inspection

When performing a quarterly inspection, also perform a daily inspection. When performing an annual inspection, always perform a quarterly inspection and a daily inspection.

Mark the appropriate box beside each inspection procedure: A for acceptable or U for unacceptable.

NOTES:

Daily Inspections	A	U
Operator's Manual		
Visual Inspection		
Function Test		

Quarterly Inspections	A	U
Inspect the Welds		
Clean the Mast Sections		
Inspect the Winch		
Lubricate the Winch		

Annual Inspections	A	U
Lubricate Casters and Wheels		
Inspect the Mast Assembly for Wear		
Replace the Brake Lining Plates on the Winch		
Inspect the Paint on the Material Lift		

If U (Unacceptable) is marked for any inspection procedure, tag the material lift and remove it from service until repairs are completed according to manufacturer's specifications.

After making repairs to a damaged material lift, ALWAYS perform a new full inspection before returning the material lift to service.

Only authorized and trained personnel should perform maintenance on the material lift.

THIS PAGE INTENTIONALLY LEFT BLANK

