

Service Manual Trucks

Group **38**

Instrumentation

VNL, VNM

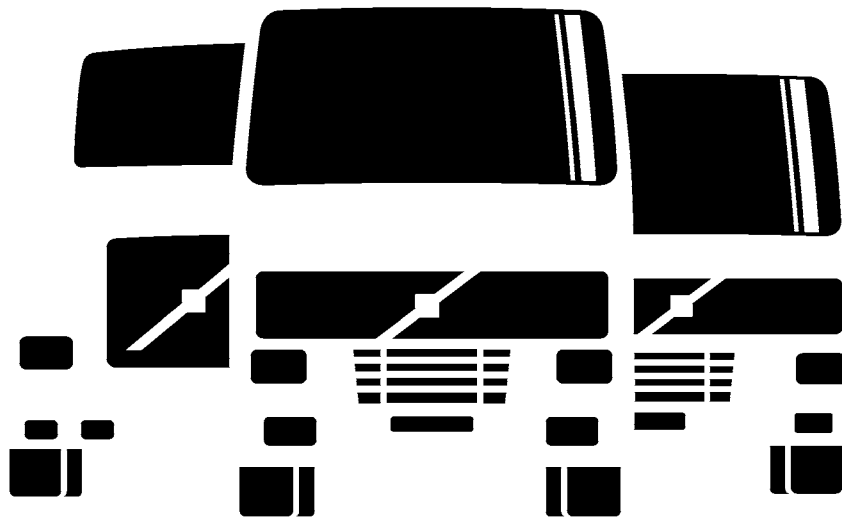

Foreword

The descriptions and service procedures contained in this manual are based on design and method studies up to June 1996.

The products are under continuous development. Vehicles and components produced after the above date may therefore have different specifications and repair methods. When this is believed to have a significant bearing on this manual, supplementary service bulletins will be issued to cover the changes.

The new edition of this manual will update the changes.

In service procedures where the title incorporates an operation number, this is a reference to an S.R.T. (Standard Repair Time).

Service procedures which do not include an operation number in the title are for general information and no reference is made to an S.R.T.

The following levels of observations, cautions and warnings are used in this Service Documentation:

Note: Indicates a procedure, practice, or condition that must be followed in order to have the vehicle or component function in the manner intended.

Caution: Indicates an unsafe practice where damage to the product could occur.

Warning: Indicates an unsafe practice where personal injury or severe damage to the product could occur.

Danger: Indicates an unsafe practice where serious personal injury or death could occur.

Volvo GM Heavy Truck
Greensboro, NC USA

Order number: PV776-TSP23762/1

© 1996 Volvo GM Heavy Truck, Greensboro, NC USA

All rights reserved. No part of this publication may be reproduced, stored in retrieval system, or transmitted in any forms by any means, electronic, mechanical, photocopying, recording or otherwise, without the prior written permission of Volvo GM Heavy Truck.

Contents

General	3
General cautions	3
Basic description	4
Specifications	4
Tools	7
Special tools	7
Special equipment	8
Design and Function	11
Gauges and indicators	13
Connector pinouts	34
Troubleshooting	39
General service information	39
Troubleshooting individual gauges	40
Left section	42
Center section	46
Right section	48
Troubleshooting with the MPSI Pro-Link 9000 and VOLVO Cartridge	52
Service Procedures	55
Updating the odometer reading after replacing the cluster	55
Cleaning the housing and front panel glass	55
Bulb replacement	55
Removal	55
Installation	56
Instrument cluster replacement	56
Removal	56
Installation	57
Gauge replacement, right circuit board gauges	58
Removal	58
Installation	60
Center module replacement	61
Removal	61
Installation	63
Gauge replacement, left circuit board gauges	64
Removal	64
Installation	66

General

General cautions

CAUTION

When servicing or troubleshooting, do not leave the cluster face-down for more than 15 minutes, or damage to the gauges may occur. Gauge oil may run out of the front of the gauge faces and make the gauges inaccurate.

CAUTION

Welding on trucks can damage the vehicle electrical system/components from the voltage and current spikes that normally occur when welding. It is preferable to avoid welding on an assembled truck, but if welding must be done on any structure on or in contact with the vehicle, disconnect the electrical connectors at the rear of the instrument cluster.

Preventing electrostatic discharge (ESD)

CAUTION

To prevent electrostatic discharge (ESD), which may damage the sensitive electronic components in the instrument cluster, a wrist grounding strap must be used when working on electronic equipment such as the instrument cluster. Failure to use a wrist strap may result in permanent damage to the printed circuit boards in the instrument cluster. To use the wrist strap in a vehicle, attach the alligator clip to the nearest electrical ground such as a metal mounting screw, a ground terminal or preferably a ground stud.

CAUTION

To prevent electrostatic discharge (ESD), which may damage the sensitive electronic components in the instrument cluster, make sure the workbench has an anti-static mat which is grounded to the nearest electrical outlet when working on the instrument cluster. Failure to use an anti-static mat may result in permanent damage to the printed circuit boards in the instrument cluster. When working at the anti-static workbench, always keep a wrist strap connected to the anti-static mat.

Human skin can hold more than 1000 volts of static electricity. Although getting a static shock is annoying, it is not dangerous because there is so little energy stored by clothing. But when dealing with circuits designed to sense differences smaller than 1 volt, electrostatic discharge can be a subtle but destructive problem. Circuit boards mounted in the instrument cluster or in modules mounted elsewhere may not fail immediately after being hit with a static discharge. Rather they may work for a while, then fail for no apparent reason. The culprit then is often the normal warming up and cooling down process of the module, engine or cab interior.

Grounding straps and anti-static mats are available for minimal cost from electronic supply stores. Grounding straps consist of a wrist strap, a coiled extension wire and an alligator clip. Be sure to purchase one with a long enough extension wire to allow freedom of movement.

An anti-static wrist strap is available from Kent-Moore (see *Tools* section of this manual). Call 1-800-328-6657.

An anti-static mat is also available from Kent-Moore (see *Tools* section of this manual).

Basic description

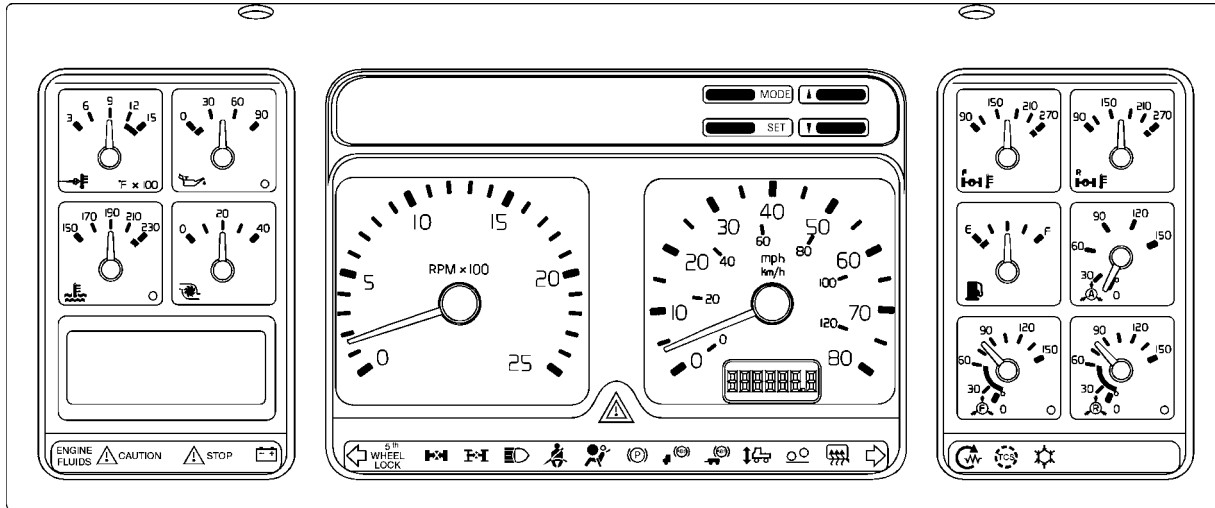

W3000787

This manual describes the 1996 AMETEK/Dixson Instrument Cluster for VN Series vehicles and how to service it. For information about the vehicle's Electronic Control Units, wiring diagrams, sensors and other components, please refer to the service manual for that component.

The cluster is available in 6 configurations, with either an mph or km/h speedometer.

The instrument cluster is divided into the following sections

- Left Section** - Contains a Coolant Temperature and an Oil Pressure gauge, and optionally, a Pyrometer and a Turbo Boost gauge. A Graphic Display module at the bottom provides additional information about the vehicle. Also contains four telltale indicators: Engine Fluids, Caution, Stop and No Charge.
- Center Section** - Contains a tachometer, speedometer and odometer. Also contains a buzzer, fourteen telltale indicators and a Master Warning indicator. Telltales in this section are: Left and Right Turn Indicators, Fifth Wheel Lock, Wheel Differential Lock, Interaxle Differential Lock, High Beam Indicator, SRS (Air Bag), Parking Brake, Anti-Lock Brake System (ABS) for Tractor (and ABS for Trailer — for future use), Air Suspension, Bogie and Mirror Defroster.
- Right Section** - Contains a Fuel Level gauge, a Front Brake Air Pressure gauge, and a Rear Brake Air Pressure gauge. It may also contain an optional Application Air Pressure gauge, and a Forward Axle and a Rear Axle Temperature gauge. It can also contain up to six telltale indicators. Standard telltales are Preheat, Traction Control System and APADS (Air Conditioning Protection and Diagnostic System — for future use).

Note that all gauges and telltales may not be used in all vehicles.

Four push-buttons above the speedometer allow the driver to access and display information in the Graphic Display.

Specifications

This instrument cluster is designed to operate with an input voltage of between +10 and +18 volts.

Available configurations

- Clock
- Trip Odometer 1 and 2
- Diagnostic Messages
- Voltmeter Gauge
- Fuel Economy

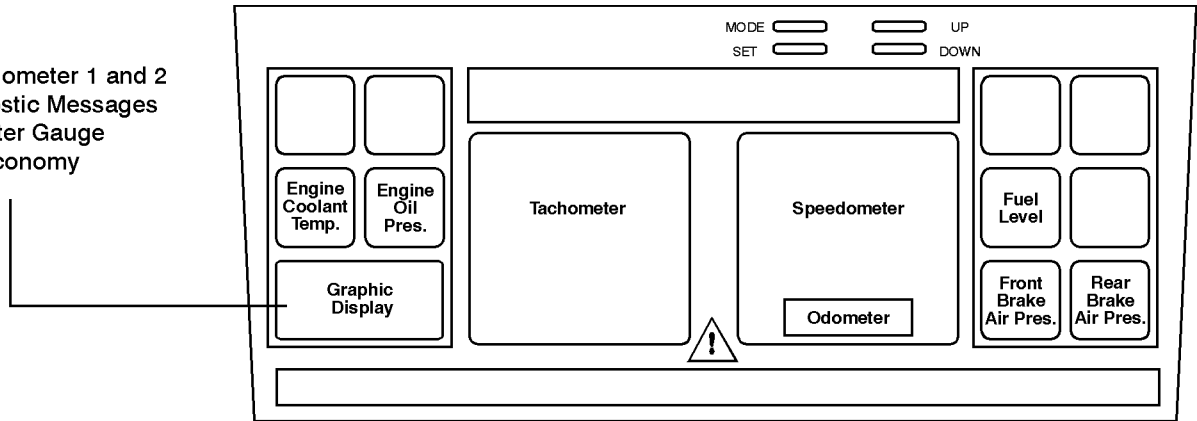

Standard Cluster

- Clock
- Trip Odometer 1 and 2
- Diagnostic Messages
- Voltmeter Gauge
- Fuel Economy

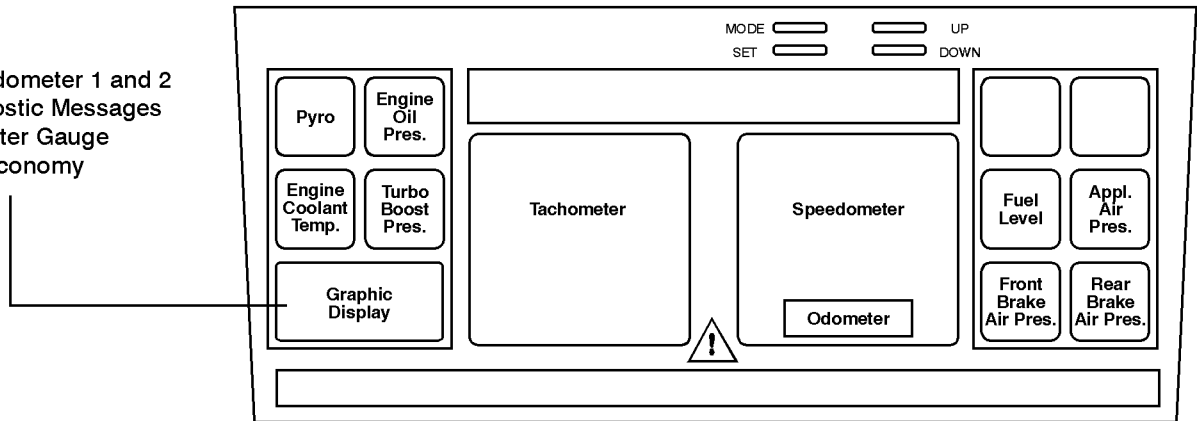

Performance Cluster

- Clock
- Trip Odometer 1 and 2
- Diagnostic Messages
- Voltmeter Gauge
- Transmission Temp. Gauge
- Engine Oil Temp. Gauge
- Fuel Economy

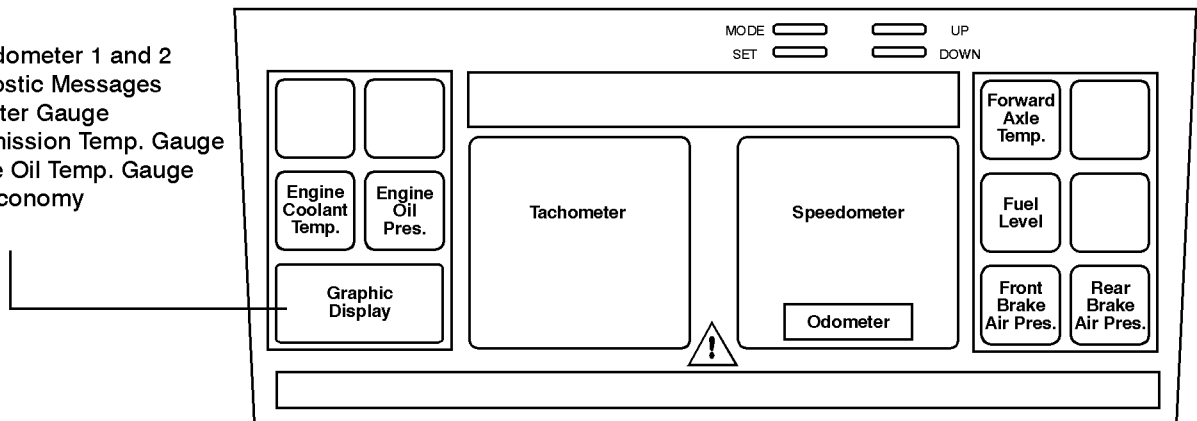

Driveline Single Axle Cluster

W3000832

Available configurations (contd.)

- Clock
- Trip Odometer 1 and 2
- Diagnostic Messages
- Voltmeter Gauge
- Transmission Temp. Gauge
- Engine Oil Temp. Gauge
- Fuel Economy

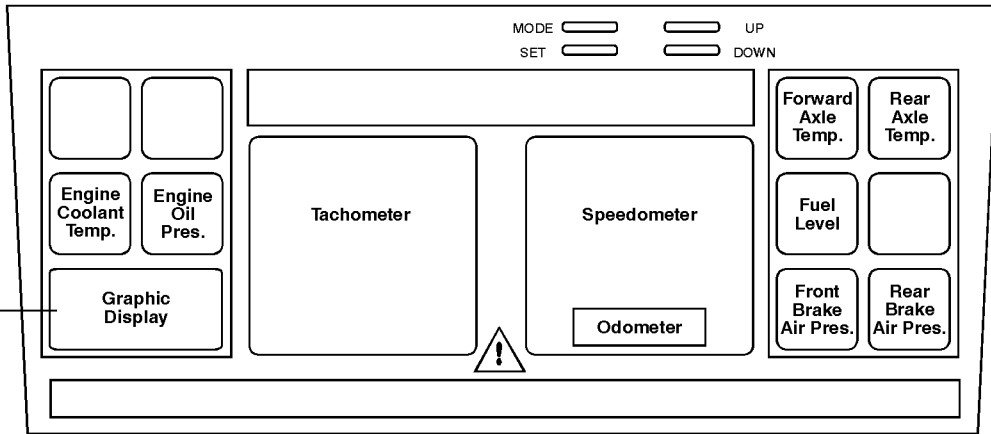

Driveline Tandem Axle Cluster

- Clock
- Trip Odometer 1 and 2
- Diagnostic Messages
- Voltmeter Gauge
- Transmission Temp. Gauge
- Engine Oil Temp. Gauge
- Fuel Economy

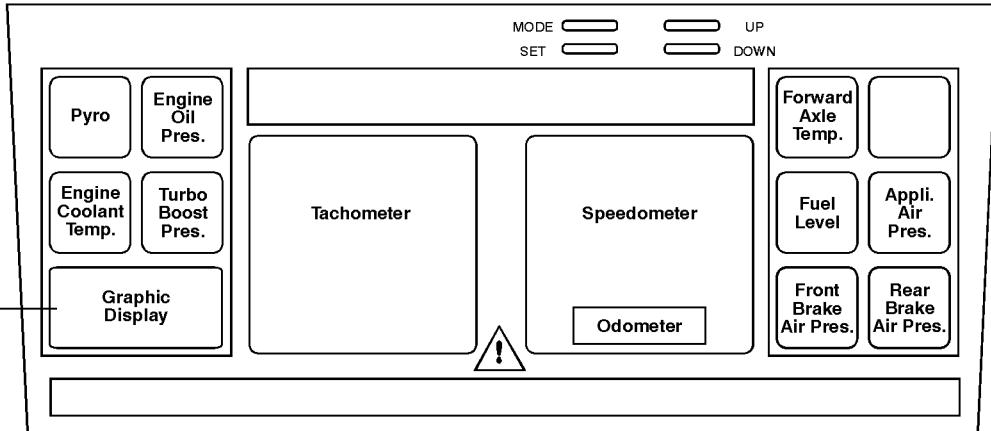

Loaded Single Axle Cluster

- Clock
- Trip Odometer 1 and 2
- Diagnostic Messages
- Voltmeter Gauge
- Transmission Temp. Gauge
- Engine Oil Temp. Gauge
- Fuel Economy

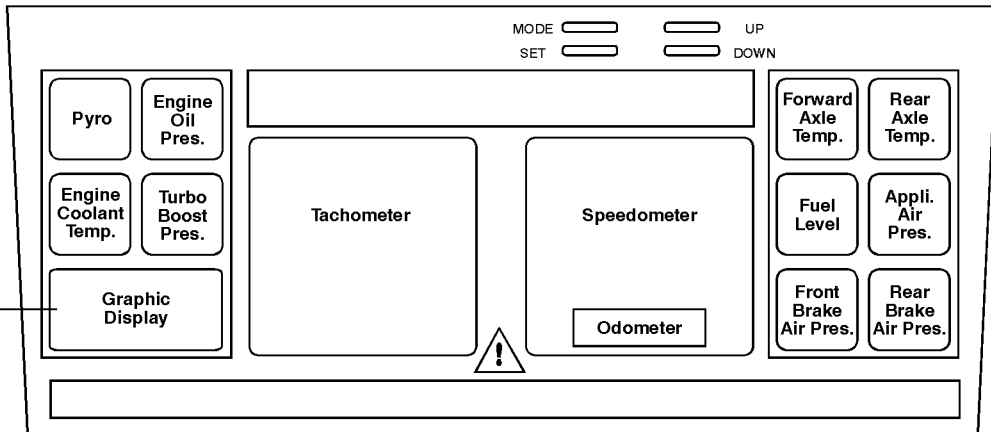

Loaded Tandem Axle Cluster

W3000833

Tools

Special tools

The following special tools are required for work on the instrument cluster. The tools can be ordered from Volvo GM Heavy Truck Corporation.

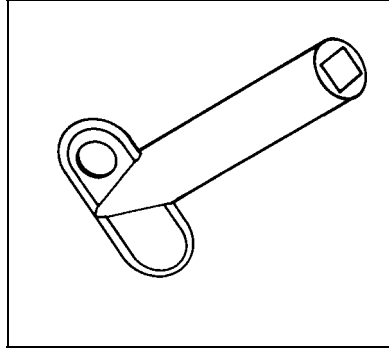

W3000642

1608077

Lamp removal tool

Special equipment

The following items are required for work on the instrument cluster. They can be ordered as shown below.

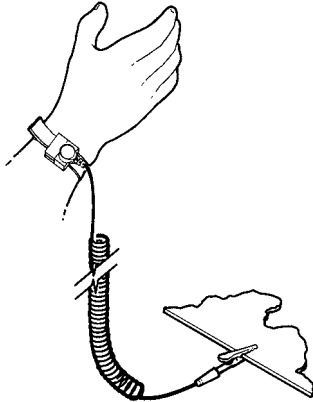

W3000572

ESD Wrist Strap

Use a wrist strap when servicing the instrument cluster inside the vehicle. Use a wrist strap and anti-static mat when working on the cluster at a workbench. Several different wrist straps are available from Kent-Moore at 1-800-328-6657.

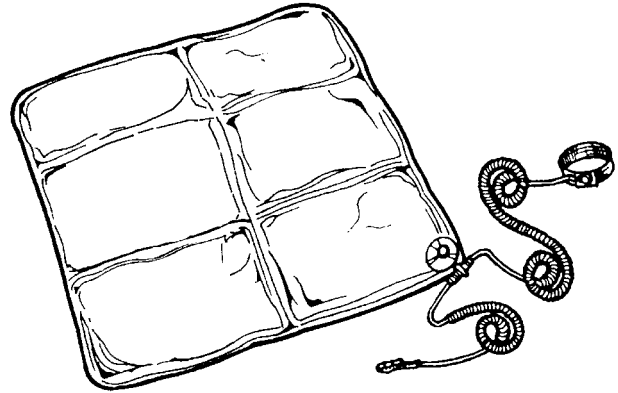

W3000704

Type 8501 Static Dissipative Grounding Kit
Available from Kent-Moore (P/N J-42444)
at 1-800-328-6657.

The kit shown includes both a wrist strap and anti-static mat. Use both when working on the instrument cluster at a workbench.

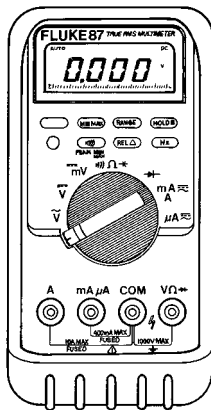

W2001014

Fluke 87 Digital Multi-meter (DMM)
Available from Kent-Moore (P/N J-39200)
at 1-800-328-6657.

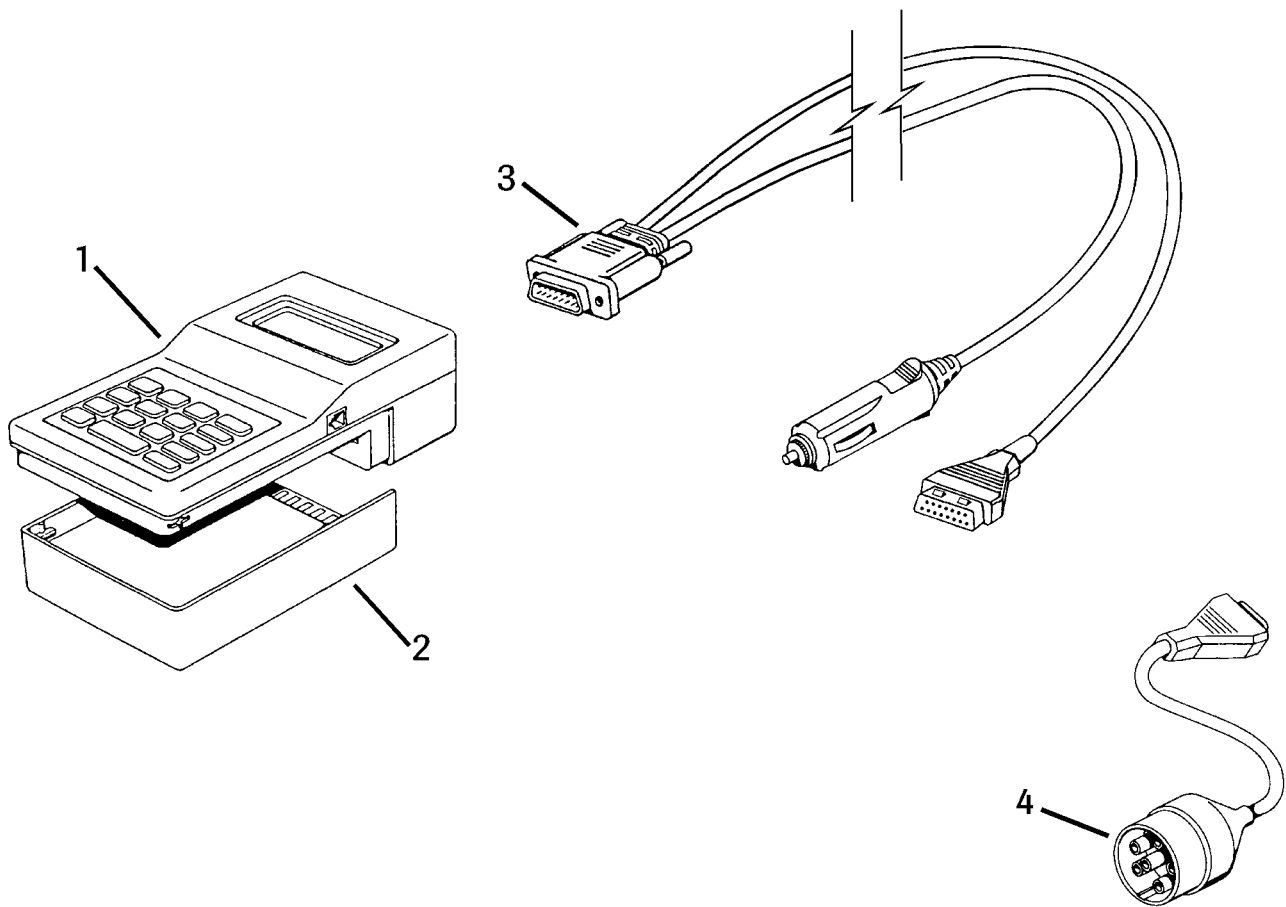
**MPSI Pro-Link 9000**

The Pro-Link 9000¹ with the VOLVO cartridge is available from Kent-Moore at 1-800-328-6657.

- 1 MPSI Pro-Link 9000
(Kent-Moore P/N J-38500-1)

- 2 VOLVO Cartridge, version 2.0
(Kent-Moore P/N J-38500-2000)
- 3 Power/Data Cable
(Kent-Moore P/N J-38500-2)
- 4 Diagnostic Adaptor Cable
(Kent-Moore P/N J-38500-60A)

W3000752

¹Pro-Link is a registered trademark of MPSI.

Design and Function

Instrument cluster block diagram for Volvo engine

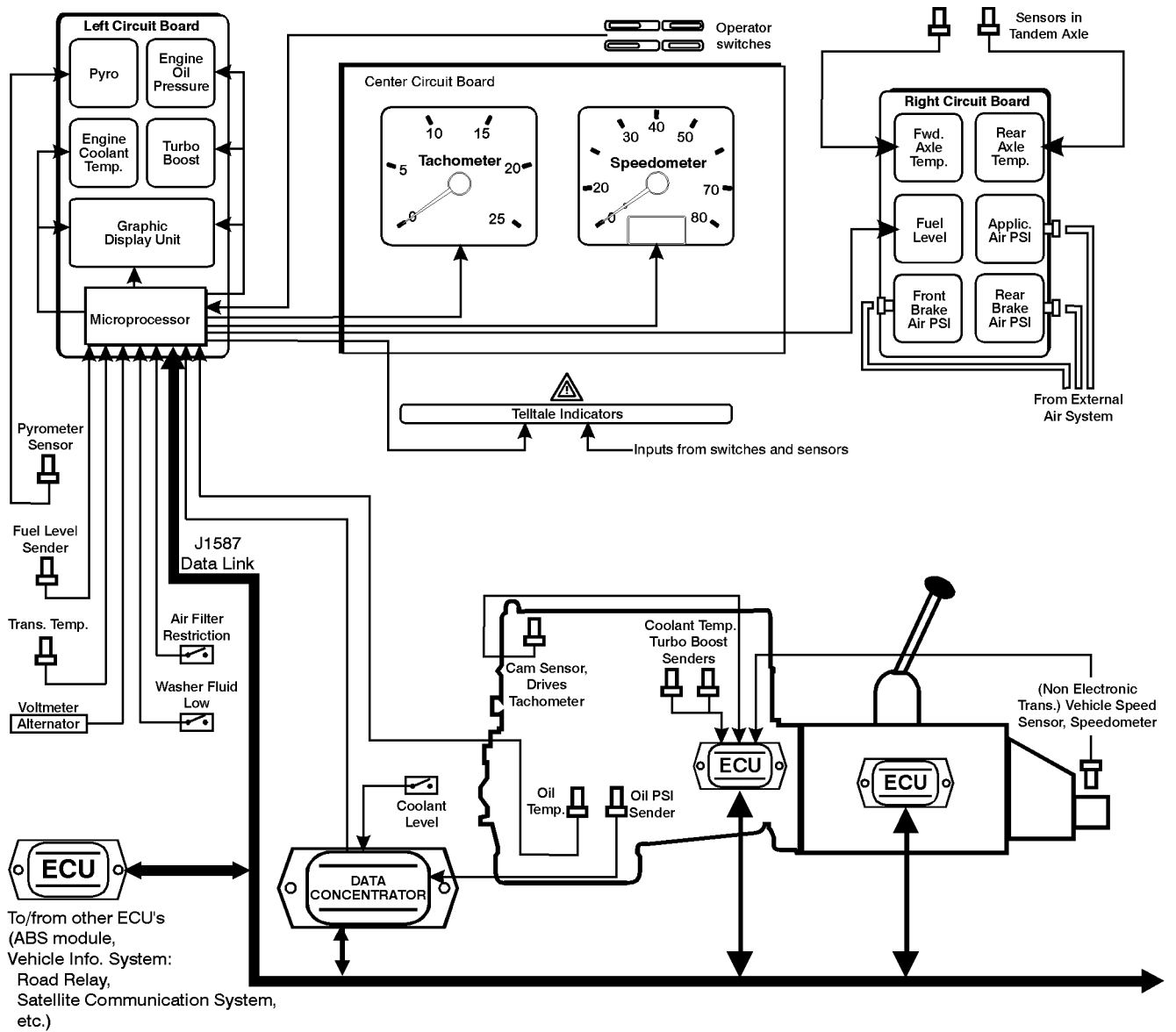

W3000864

Instrument cluster block diagram for Caterpillar, Cummins, Detroit Diesel engines

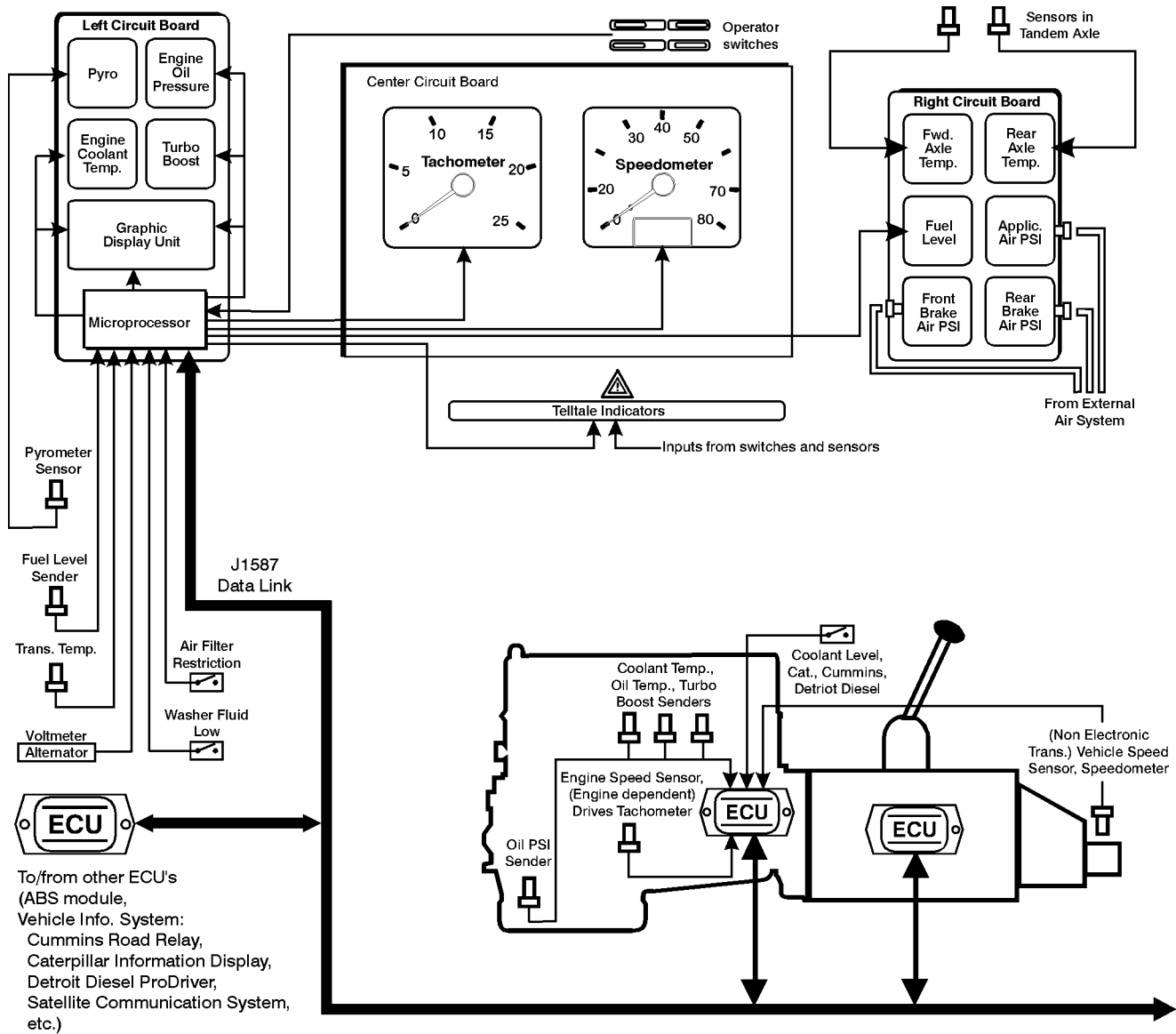

W3000865

Gauges and indicators

Left section

Pyrometer (optional)

The pyrometer indicates exhaust temperature from a sensor in the exhaust system.

The pyrometer gauge is an electrical aircore meter movement driven by a small electric current from a high-temperature thermocouple.

If the pyrometer thermocouple fails, the pointer will move to one end of the dial or the other. A reading of 149° C (300° F) or less indicates an open in the truck's wiring or thermocouple, and a reading of 815° C (1500° F) or more indicates a short.

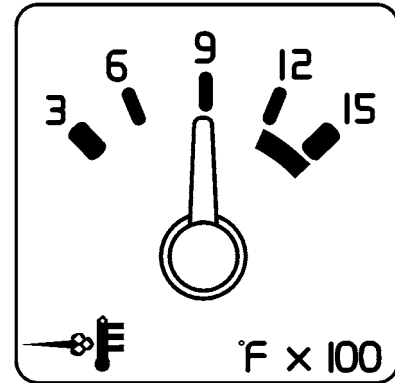

W3000601

Engine Coolant Temperature

The coolant temperature gauge is an electrical aircore meter movement which receives its signal from the engine via the SAE J1587 data bus. In the absence of a data signal, the gauge pointer will move to its minimum reading after a 3–5 second delay.

Red Warning LED illuminates when coolant temperature is too high for safe operation. The temperature which activates this LED is engine-dependent.

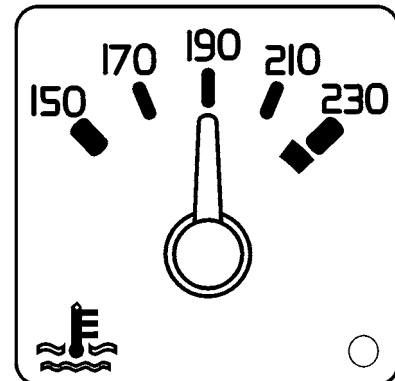

W3000602

Turbo Boost Pressure (optional)

The turbo boost pressure gauge is an electrical aircore meter movement driven by a signal from the J1587 data link. In the absence of a data signal, the gauge pointer will move to its minimum reading after a 3–5 second delay.

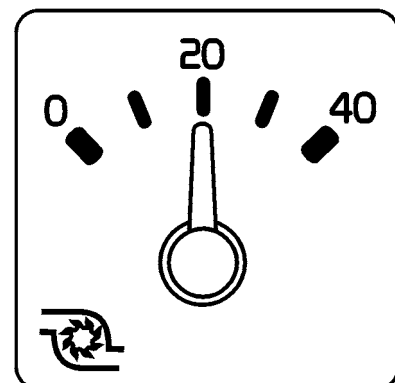

W3000604

Engine Oil Pressure

The engine oil pressure gauge is an electrical aircore meter movement that receives its signal from a sender unit mounted on the engine. For Caterpillar, Cummins and Detroit Diesel engines, the sender unit supplies data to the Engine ECU which sends engine oil pressure information to the instrument cluster via the J1587 data link.

For the Volvo VE D12 engine, the sender supplies a signal to the Data Concentrator Module which then broadcasts engine oil pressure data to the cluster via the J1587 data link.

In the absence of a data signal, the gauge pointer will move to its minimum reading after a 3–5 second delay.

Note: Engine oil operating pressure is engine dependent.

A Red Warning LED illuminates when engine oil pressure is too low for safe operation. The pressure which activates this LED is engine-dependent.

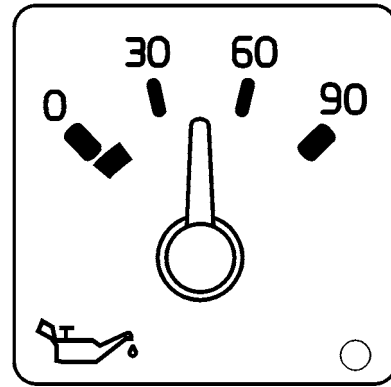

W3000983

Telltale lamps. left section

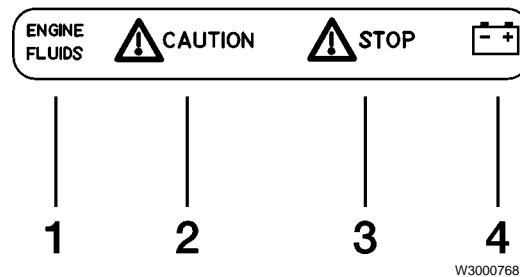

- 1 Engine Fluids lamp
- 2 Caution lamp
- 3 Stop lamp
- 4 No Charge lamp

Engine Fluids

Illuminates when engine oil pressure or coolant level is too low, or when engine coolant temperature is too high. Hard-wired to the Data Concentrator Module (Volvo engine), or to the engine ECU (Cummins engine).

Note: The Engine Fluids lamp is not used in vehicles with Caterpillar or Detroit Diesel engines.

Caution

Illuminates to indicate a control system or component malfunction (for example: throttle position sensor, boost pressure sensor).

For the VE D12 engine only, it will also illuminate (solid) during engine ECU programming. Also for the VE D12 only, the Caution lamp is always on for 3–5 seconds when the key switch is turned to the Ignition position.

Note: This lamp replaces the Check Engine lamp in earlier model vehicles.

Stop

Illuminates to alert the driver that an engine problem has been detected by the engine ECU, and that action may be taken by the ECU to protect the engine. (for example, engine oil pressure, low coolant level).

No Charge

Illuminates when a problem exists in the charging system. A voltage output decrease of 1–2 volts from normal will cause this lamp to illuminate dimly. As the voltage output decreases more, the illumination goes from dim to bright.

Engine-related Warnings: Volvo VE D12						
Conditions	Engine Fluids Lamp	Caution Lamp	Stop Lamp	Display icon /message	Gauge LED	Engine Protection (Note 5)
Low Coolant Level (Source: switch, Data Concentrator)	On, Solid	—	On, Solid	Icon Blinking	N/A	Shutdown Active
Low Oil Pressure, with Oil Pressure <36.2 psi, and >1000 RPM for 2 sec.	Blinking	—	—	Message on Request (Note 4)	On	Shutdown Inactive
Low Oil Pressure, with Oil Pressure <9 psi (Source: Data Concentrator)	Blinking	—	—	Message on Request (Note 4)	On	Shutdown Inactive
Low Oil Pressure, with Oil Pressure <6 ±0.5 psi (Source: Data Concentrator)	On, Solid	—	On, Solid	Message on Request (Note 4)	On	Shutdown Active
High Coolant Temperature (Source: Engine) (Note 1)	Blinking (Note 3)	Blinking	—	Message on Request (Note 4)	On	Engine Hp Output Derated
High Oil Temperature (Source: Engine, Sender)	—	On, Solid	—	Icon On	N/A	N/A
Other Engine-Related Fault Codes (Note 1)	—	Blinking	—	Message on Request (Note 4)	N/A	N/A
During Programming (Note 2)	On, Solid	On, Solid	—	N/A	N/A	N/A
Audible Buzzer	Yes	N/A	Yes	N/A	N/A	N/A

Note: When Key switch = Ignition position: Engine Fluids lamp is on. Caution lamp is on solid for 3–5 seconds.

- 1 Lamp remains flashing even when the fault becomes inactive. The key switch must be cycled to turn off the lamp.
- 2 Ignition on, engine not running.

- 3 Source = Data Concentrator Module (DCM), when an above normal operational range for coolant temperature condition is broadcast on the data bus.
- 4 Message on Request = Cluster Diagnostic Messages, which are displayed in the Graphic Display Diagnostic Mode.
- 5 Engine Protection is not controlled by the instrument cluster. It is a programmable parameter.

For more information, refer to the *Electronic Control System, VE D12 — VOLVO* manual.

Engine-related warnings, Caterpillar 3406E and Detroit Diesel Series 60 11.1/12.7

Caution and Stop Lamp signals are sourced from the Engine ECU (hard-wired). Caterpillar and Detroit Diesel do not use the Engine Fluids lamp.

Refer to the engine manufacturer's literature for information on the conditions which activate individual lamps in the instrument cluster.

Engine-related warnings, Cummins M11/N14

The Engine Fluids, Caution and Stop Lamp signals are sourced from the Engine ECU (hard-wired).

Refer to the engine manufacturer's literature for information on the conditions which activate individual lamps in the instrument cluster.

Graphic Display

The Graphic Display is located below the gauges in the left section of the instrument cluster. It displays vehicle system information not available from the other gauges, and helps the driver obtain maximum efficiency from the vehicle.

Standard displays include an alarm clock, voltmeter, engine hours, two resettable trip odometers, a fuel economy display and diagnostic information. Optional displays include engine and transmission oil temperature gauges.

Displayed data can come from

- the J1587 data link
- external switches
- external sensors.

The display can be customized to suit individual preferences. For example, its backlighting can be adjusted independently of gauge backlighting.

When the ignition is on and the vehicle is not moving, the Graphic Display can also be used to help diagnose the cluster and external problems.

If battery power is lost, the Graphic Display will default to the clock display. When power is regained, the clock will come on, flashing, and will need to be reset.

Automatically activated warnings

Low
Coolant



Air Filter
Restriction



Washer Fluid
Low



W3000709

Automatically Activated Telltale Warnings Appearing in the Graphic Display

Should a condition requiring attention occur, a telltale warning message identifying that condition will override the current display. For example, if the engine coolant level drops below a predetermined point while the clock is displayed, a low coolant display will replace the clock display.

Telltale warnings:

Low coolant

- The low coolant warning display is activated by an input from the low coolant sensor, and will stay on until the problem is corrected.
- Note that engine shutdown mode may be engaged by a low coolant condition (this is an engine dependent parameter).
- The low coolant sensor is a normally open switch, and is closed by a low coolant level. To clear the low coolant display, check for proper coolant level. If

adding coolant does not correct the problem, check the coolant sensor for continuity between pins A and B, then check the wiring.

Air filter restriction

- The air filter restriction display and a buzzer will sound ONLY during the first 10 seconds after ignition. The air filter restriction sensor is a normally open switch closed by approx. 25 Hg.
- If this warning appears, check the air filter restriction gauge at the air filter assembly to see that it has an approximate reading of 25 Hg. If so, replace the filter and reset the mechanical gauge at the air filter. If the gauge is not reset, the warning will still appear in the instrument cluster.
- If the warning still appears after these steps, check the air filter restriction gauge for continuity between pins A and C. If there is continuity between pins A and C replace the air filter restriction gauge.
- If the warning still appears after these steps, troubleshoot the air filter restriction gauge circuit.

Washer fluid low

- The washer fluid low warning will be displayed when the washer fluid drops below a predetermined level. The washer fluid low warning is a normally open switch located on the washer fluid pump assembly, which is closed by a low washer fluid condition.
- The warning activation has a 10 second delay to allow for fluid slosh.
- This warning may be cleared by pressing the instrument cluster's Set button. The warning will reappear each time the key is cycled off and on.
- If adding washer fluid does not clear the warning, check the washer fluid pump assembly for continuity between connector pins B and C. If there is continuity, replace the pump assembly. If the warning is still displayed, troubleshoot the washer fluid pump circuit.

Gauge warnings:

- If a gauge warning such as voltmeter, engine or transmission oil temperature occurs, the CAUTION lamp will come on and the gauge warning will be displayed. But if a telltale warning is already displayed, the Mode button must be pressed to display the warning on the Graphic Display screen.
- Gauge warnings are activated when the input exceeds a pre-set trip point. The trip points are as follows, shown in order of priority:

Note: Engine oil temperature trip point varies by engine.

- 1) Engine oil temp VE D12: 130°C (265°F)
- 2) Transmission oil temp 140°C (285°F)
- 3) Voltmeter 16 volts

Multiple warnings:

- If more than one telltale warning message is activated, 2 or 3 warning icons may be displayed at the same time. A multiple display appears as shown in the illustration.

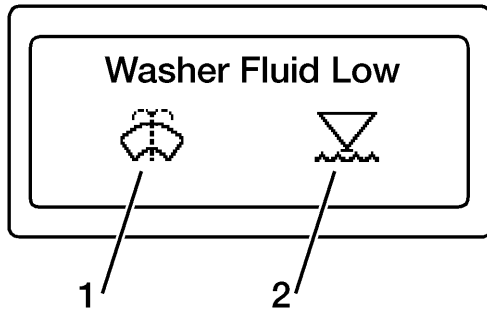

W3000848

- 1) Washer Fluid Low icon in the Primary display location
- 2) Low Coolant icon in the Secondary display location

The icon *on the left side* is the primary icon during multiple displays. If, as in the illustration, the washer fluid low icon is in the primary position, it may be cleared by pressing the Set button.

- The text displayed above the icons is always that of the icon in the primary position. If the icon is in the right, or secondary position, it cannot be cleared. Note that the low coolant icon cannot be cleared until the problem is corrected.
- Every 8 seconds the display will change, and the primary and secondary icons will switch positions.
- If a gauge warning occurs while a telltale warning is displayed, the CAUTION lamp will illuminate. A gauge warning will not automatically replace a telltale warning. To view the gauge warning in the display, the Mode button must be pressed.

For troubleshooting, the diagnostic mode may be entered while any of these warnings are displayed.

Using the Graphic Display

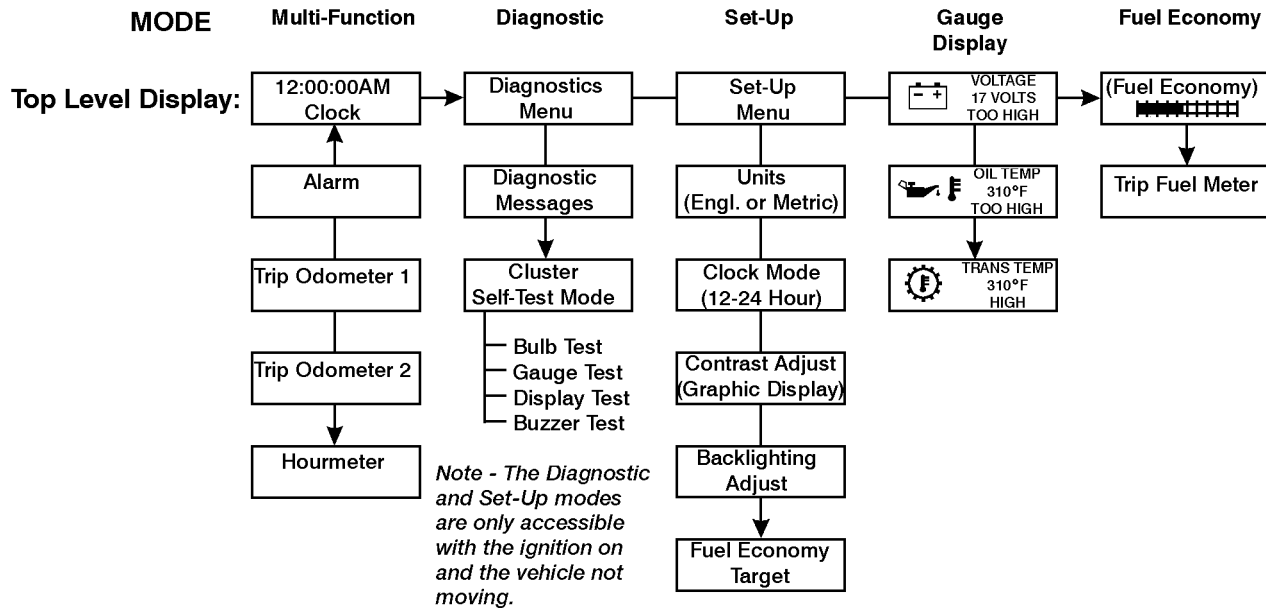

W3000867

Graphic display modes

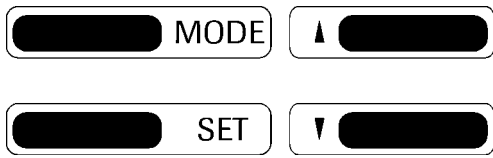

W3000639

- **Mode button** - Pressing the Mode button moves from one mode to another. For example, press MODE to change from the Set-Up mode to the Gauge mode.
- **Up and Down buttons** - Pressing the Up or Down buttons scrolls to the next or to the previous available function within a mode. For example, if the Trip 1 odometer is displayed, pressing Down scrolls to the Trip 2 odometer, and pressing Up scrolls to the Alarm Clock. The Up and Down buttons are also used to change the displayed time and alarm.
- **Set button** - If the current display contains a value which can be changed using the Up and Down buttons, the Set button enables the change and selects the digit to be changed. The Set button also resets the Trip Odometer 1 and Trip Odometer 2 readings to zero when pressed for 1 second.

To use the menu system:

DANGER

If the vehicle is in motion, reach around the steering wheel with the right hand to access the control buttons to avoid possible personal injury. Accessing the control buttons through the steering wheel can result in injury or death due to loss of vehicle control.

- 1 Turn the ignition on.
- 2 Using the right hand, reach around the steering wheel and press the Mode button to select the desired mode.
- 3 When the desired mode appears, use the Up and Down buttons to select the desired function in that mode.

Note: The Diagnostic and Set-up Modes are not available when the vehicle is in motion. If these modes are in use and the vehicle reaches a speed of 5 mph, the Graphic Display will automatically change to the clock display.

Multi-Function mode

The Multi-Function mode contains a clock, an alarm clock, two independent trip odometers, and an engine hourmeter.

Clock display

The clock displays the current time in either a 12-hour format (12:00:00 am to 12:59:59 pm) or a 24-hour format (00:00:00 to 23:59:59). The choice is made in the Set-Up Menu.

1 To display the clock:

- a. Use the Mode button to select the Multi-Function mode.
- b. Use the Up or Down button to display the time.

2 To change the time display:

- a. When the clock time is displayed, press the Set button to select the hours digits. The hours digits will flash when selected.
- b. When the hours digits flash, use the Up and Down buttons to set the desired hour.
- c. Press the Set button a second time to select the minutes digits. The minutes digits will flash when selected.
- d. When the minutes digits flash, use the Up and Down buttons to set the desired minute.
- e. To accept the displayed time and exit the set time function, press the Set button a third time.

3 To change the time format:

Use the Clock Mode function of the Set-Up Menu.

Alarm clock display

The Alarm Clock function determines when the alarm reminder sounds. Set the reminder time and enable the alarm by using the Alarm Clock function.

1 To display the alarm clock:

- a. Use the Mode button to select the Multi-Function mode.
- b. Use the Up or Down button to display ALARM.

2 To change the alarm time:

- a. Display the alarm clock.
- b. When the alarm time is displayed, press the Set button to select the hours digits. The hours digits will flash when selected.
- c. When the hours digits flash, use the Up and Down buttons to set the desired hour.

d. Press the Set button a second time to select the minutes digits. The minutes digits will flash when selected.

e. When the minutes digits flash, use the Up and Down buttons to set the desired minute.

f. To accept the displayed alarm time and exit the set function, press the Set button a third time. The alarm will automatically be enabled and the Bell symbol will appear.

3 To enable the reminder tone:

Press and hold the Mode button. The next mode display will appear when the reminder is set. The clock display with a bell will appear on screen.

OR Select the Alarm Clock display as previously described.

4 To disable the reminder tone:

When the bell symbol is displayed, press and hold the Mode button until the next mode display appears. The clock display will appear without the bell symbol.

5 To silence the reminder:

Press any of the four buttons while the reminder is sounding.

Trip Odometer displays

Two independent trip odometers are available (Trip Odometer 1 and Trip Odometer 2). Each one displays the distance traveled since it was last reset.

1 To display a trip odometer:

- a. Use the Mode button to select the Multi-Function mode.
- b. Use the Up and Down buttons to display either TRIP ODOMETER 1 or TRIP ODOMETER 2.

2 To reset a trip odometer:

- a. Display the trip odometer to be reset (1 or 2).
- b. Press and hold the Set button for 1 second.

Hourmeter display

The hourmeter accumulates and displays the total time the engine has been running. It is not resettable by the driver. To display the hourmeter:

- 1 Use the Mode button to select the Multi-Function mode.
- 2 Use the Down button to scroll to HOURMETER.

Diagnostics mode

The Diagnostics mode provides two functions:

- **Diagnostic Messages** - Reports the status of various vehicle sub-systems.
- **Cluster Self Test Mode** - Contains several tests to check the cluster.

Diagnostic messages

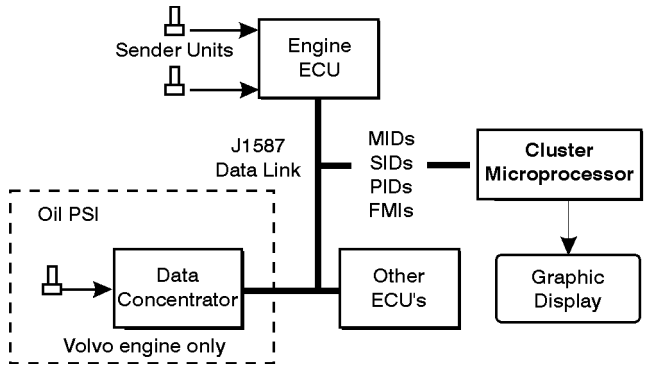

W3000851

Diagnostic message path

The vehicle contains one or more Electronic Control Units (ECU's). Each ECU monitors or controls a particular vehicle sub-system. For example, an Engine ECU monitors engine conditions, a Anti-lock Brake System ECU monitors ABS conditions, and so on.

The ECU's are connected to each other and to the cluster by a pair of wires known as the SAE J1708/1587 data link. The ECU's communicate with each other by sending and receiving messages in a format specified by SAE J1587.

Note: SAE J1587 is an industry standard which defines the format of electronic signals and information transmitted between truck and bus electronic components. SAE J1708 defines the hardware and basic protocol (data formatting) requirements for the truck and bus electronic communications system.

The cluster can display active and inactive fault codes in the Graphic Display. The message path from the J1587 data link to the Graphic Display is shown in the figure.

Each diagnostic message consists of a Message Identifier (MID) code, a Sub-system Identifier (SID) or Parameter Identifier (PID) code, and a Fault Mode Indicator (FMI) code. An FMI describes the type of failure detected in the subsystem identified by the PID or SID. The codes are standardized and are listed in the SAE J1708/1587 Specification. A list of codes which may be displayed as text messages is shown in the following section.

The figure on the following page is an example of a message indicating that a problem with the engine coolant temperature has been detected. In this example, the fault still exists, and has occurred five times.

To see diagnostic messages:

- 1 Turn on the ignition. The engine may be started. Diagnostic messages from all J1708/1587-supported vehicle systems are accessible.
- 2 Use the Mode button to display DIAGNOSTICS MENU.
- 3 Use the Up and Down buttons to display DIAGNOSTIC MESSAGES.
- 4 When DIAGNOSTIC MESSAGES is displayed, press the Set button. RECEIVING DATA, PLEASE WAIT will be displayed while the systems on the J1587 data link are polled.
- 5 When the first message appears, the Set button can be pressed to toggle the display between the text description and the received data. If the display shows "UNKNOWN" in any line, press the Set button to display the MID, PID or SID and FMI.
 - a. If the condition that caused the currently displayed fault still exists, the cluster will display "ACTIVE."
 - b. If the condition that caused the currently displayed fault has gone away, the cluster will display "INACTIVE."
 - c. The number of times a fault has occurred will be displayed when available. In some cases, a short message may also be displayed.
- 6 Record all codes displayed.
- 7 To display the next stored fault, press the Down button.

If the Graphic Display detects a *complete* failure of the J1587 data link between the instrument cluster and the other system modules, it will display DATA LINK BROKEN. In this case, the actual wires used for the J1587 data link should be inspected for damage.

If the Graphic Display does not receive a response from any of the individual modules on the J1587 data link, it will display the name of the system and NOT RESPONDING.

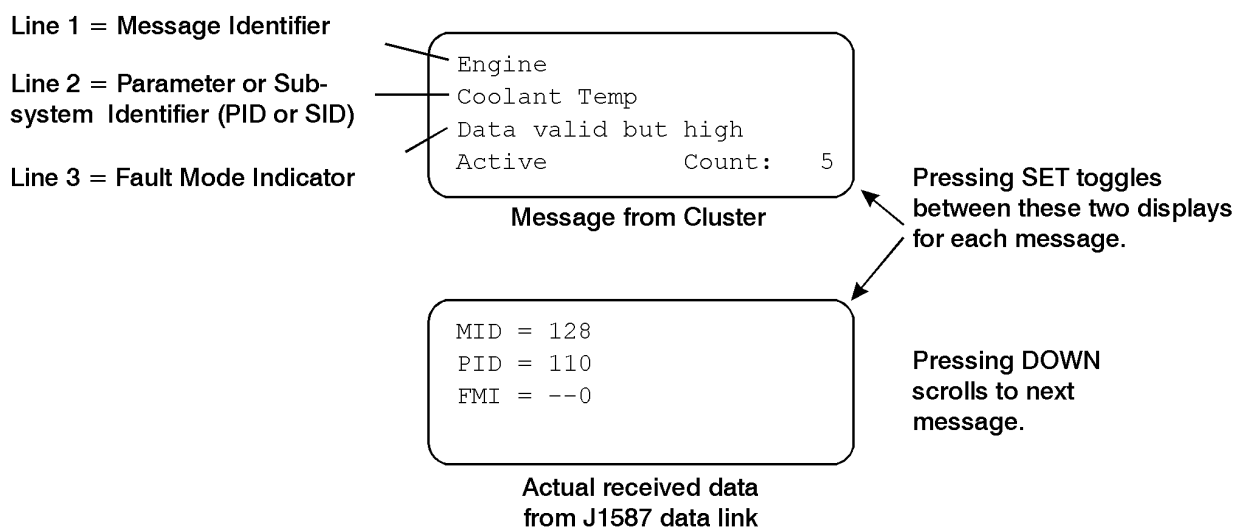

W3000866

Example of a diagnostic message in the Graphic Display

Graphic display messages supported

MID's (Message ID's or sources)	Description
128	Engine
130	Transmission
136	ABS
140	Instrument
178	Data Conc (Note: VE D12 engine only)
232	SRS (Airbag)
Additional MID's (text message will not be displayed)	
MID's (Message ID's or sources)	Description
137	Brakes, Trailer #1
138	Brakes, Trailer #2
139	Brakes, Trailer #3
141	Trip Recorder
162	Vehicle Navigation Unit
166	Tires, Power Unit
171	Driver Information Center
172	Off-board Diagnostics #1
179	Data Logging Computer
181	Communication Unit - Satellite
191	Vehicle Location Unit
231	Communication unit - Satellite/GPS/cellular

PID's (Parameter ID's)	Description
62	Retarder inh status
71	Idle shutdn status
84	Road speed
91	% Throttle pedal
100	Engine oil pressure
102	Boost pressure
105	Air inlet temperature
106	Air inlet pressure
108	Barometric pressure
110	Engine coolant temp
111	Coolant level
127	Transmission oil PSI
160	Main shaft speed
161	Input shaft speed
175	Engine oil temperature
177	Transmission oil temperature
190	Engine speed
191	Transm. output RPM

Common SID's (Subsystem ID's)	Description
233	Controller #2
236	Power contact device
237	Start enable solenoid
242	CC resume switch
243	CC set switch
244	CC enable switch
245	Clutch pedal switch
246	Brake pedal switch #1
247	Brake pedal switch #2
248	Proprietary data link
249	SAE J1922 data link
250	SAE J1708 data link (Note: J1708/J1587)
251	Power supply
252	Calibration module
253	Calibration memory
254	Controller #1

Engine SID's (Subsystem ID's)	Description
1	Injector #1
2	Injector #2
3	Injector #3
4	Injector #4
5	Injector #5
6	Injector #6
21	Engine position sensor
22	Timing sensor
25	Ext. Engine protection sig.

Transmission SID's (Subsystem ID's)	Description
1	C1 Solenoid valve
2	C2 Solenoid valve
3	C3 Solenoid valve
4	C4 Solenoid valve
5	C5 Solenoid valve
6	C6 Solenoid valve
7	Lockup solenoid valve
16	Neutral start output
18	Shift selector #1
27	Lockup clutch PSI sw
28	Forward range PSI sw
29	Neutral range PSI sw
30	Reverse range PSI sw

Vehicle Navigation SID's (Subsystem ID's)	Description
1	Dead reckoning unit
2	Loran receiver
3	Global positioning system (GPS)
4	Integrated navigation unit

Brake SID's (Subsystem ID's)	Description
1	ABS Snsr axle 1 L
2	ABS Snsr axle 1 R
3	ABS Snsr axle 2 L
4	ABS Snsr axle 2 R
5	ABS Snsr axle 3 L
6	ABS Snsr axle 3 R
7	ABS valve axle 1 L
8	ABS valve axle 1 R
9	ABS valve axle 2 L
10	ABS valve axle 2 R
11	ABS valve axle 3 L
12	ABS valve axle 3 R
13	ABS rtrdr ctrl relay
14	ABS relay, diagonal 1
15	ABS relay, diagonal 2
18	ABS, dif 1 - ASR valve
19	ABS, dif 2 - ASR valve
22	Speed signal input
23	Warning light bulb
24	ASR light bulb
31	Trailer brake slack out of adjustment, forward axle left
32	Forward axle right
33	Rear axle left
34	Rear axle right
35	Trailer brake slack out of adjustment, axle 1 left
36	Axle 1 right
37	Axle 2 left
38	Axle 2 right
39	Axle 3 left
40	Axle 3 right

FMI's (Failure Modes)	Description
0	Data valid, but high
1	Date valid, but low
2	Data erratic
3	Voltage shorted high
4	Voltage shorted low
5	Current low or open C
6	Current high or short C
7	Mech syst no respons
8	Abnormal freq or PW
9	Abnormal update rate
10	Abnormal change rate
11	Failure unknown
12	Bad device
13	Out of calibration
14	Special instruction (see Note)

A complete list of MIDs, PIDs, SIDs and FMIs is published in the SAE J1708/1587 document

Note: The special instruction FMI #14 is broadcast when the airbag has stored crash data, or by the data concentrator when the engine shutdown output has been activated.

Cluster self-test mode

As an aid in troubleshooting the cluster, the cluster self-test mode provides the following tests:

Note: While in the cluster self-test mode, the engine ECU data link is disconnected. Therefore the gauges will not function until the cluster is out of the self-test mode.

- **Bulb test** - Turns on all telltale indicators, and red warning LEDs in the gauges which have them, for ten seconds.

Note: The gauges in the instrument cluster are not functional during the bulb test. The ignition key can be cycled off and on to interrupt any test.

- **Gauge test** - This causes the pointers in the Tachometer, Speedometer, Oil PSI, Coolant Temperature, Fuel, and Turbo Boost gauges to sweep from minimum scale to full scale and back, briefly stopping at mid-scale each way. This occurs three times. The pyrometer, axle temperature and air pressure gauges are excluded from the self test. Cycle the ignition key off and on after the gauge test to return the gauges to normal function.

Note: Each time power is applied to the cluster, the speedometer and tachometer pointers return to zero, taking the shortest path (usually counter-clockwise). If (during shipment, for example) the pointers are at the high end of their scales, they will move clockwise towards zero when power is applied, and will be prevented from reaching zero by the gauge housing. In this case, use the Gauge Test function to return the tachometer and speedometer pointers counter-clockwise to zero.

- **Display test** - To help identify defects in the Graphic Display, the display will alternate between all dark and all light for about 10 seconds:

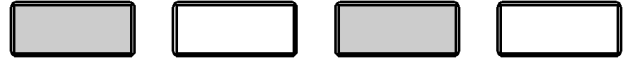

W3000719

- **Buzzer test** - Sounds each of the three buzzer signals for 10 seconds each.

- 1 To access the Cluster Self Test:
- 2 Use the Mode button to display DIAGNOSTICS MENU.
- 3 Press the Up or Down button to scroll to CLUSTER SELF TEST MODE.
- 4 Press the Set button to activate the Cluster Self Test mode.
- 5 Press the Up or Down button to display the desired test name (Bulb Test, Gauge Test, Display Test, or Buzzer Test).
- 6 Press the Set button to begin the displayed test. The test will end automatically.

Set-up mode

The Set-up mode allows the driver to choose between English or metric units, between 12- or 24-hour time, and to set the Graphic Display contrast, the Graphic Display and odometer brightness, and (optionally) to set a fuel economy target value.

Settings are retained when the ignition is off, and also when the battery is disconnected. If battery power is lost *while in the Set-Up mode*, the instrument cluster will go back to its default values.

Units

The units function configures the cluster to display data in the English or metric mode.

- **English** - Distances are displayed in miles, temperatures are displayed in Fahrenheit degrees, and Fuel Economy is displayed in miles per gallon.
- **Metric** - Distances are displayed in kilometers, temperatures are displayed in Celsius degrees, and Fuel Economy is displayed in liters per kilometer.

To configure the cluster for English or metric:

- 1 Use the Mode button to display SET UP MENU.
- 2 Press the Up or Down button to scroll to UNITS.
- 3 Use the Set button to toggle between ENGLISH and METRIC.

Clock mode

The clock mode configures the clock to display 12-hour (am/pm) or 24-hour time. To change the clock format:

- 1 Use the Mode button to display SET UP MENU.
- 2 Press the Down button to scroll to CLOCK MODE.
- 3 Use the Set button to toggle between the 12- and 24-hour formats.

Contrast adjust function

This function adjusts the contrast of the Graphic Display. To adjust the display contrast level, do the following:

- 1 Use the Mode button to display SET UP MENU.
- 2 Use the Down button to scroll to CONTRAST ADJUST.
- 3 Press the Set button.
- 4 Use the Up and Down buttons to increase or decrease the contrast.
- 5 When the contrast is at the desired level, press the Set button. (If you do not press the Set button here,

the setting won't be saved — the setting will remain in effect until the ignition is turned off and will return to its previous setting when the ignition is turned back on.)

- 6 Press the Mode button to return to the SET-UP MENU display.

Backlighting adjust function

This function allows the odometer and graphic display backlighting (brightness) to be adjusted independently of the gauge backlighting. To adjust the backlighting, do the following:

- 1 Use the Mode button to display SET UP MENU.
- 2 Press the Down button to scroll to BACKLIGHTING ADJUST.
- 3 Press the Set button.
- 4 Use the Up and Down buttons to increase or decrease the backlighting.
- 5 When the backlighting is at the desired level, press the Set button. (Note: If you do not press the Set button here, the setting won't be saved — the setting will remain in effect until the ignition is turned off and will return to its previous setting when the ignition is turned back on.)
- 6 Press the Mode button to return to the SET-UP MENU display.

Fuel economy target adjust function

This function allows a fuel economy target to be set. To change the fuel economy target value, do the following:

- 1 Use the Mode button to display SET-UP MENU.
- 2 Press the Down button to scroll to FUEL ECONOMY TARGET.
- 3 Press the Set button.
- 4 Use the Up and Down buttons to increase or decrease the desired value.
- 5 When the desired value is displayed, press the Set button. (If you do not press the Set button here, the setting won't be saved — the setting will remain in effect until the ignition is turned off and will return to its previous setting when the ignition is turned back on.)
- 6 Press the Mode button to return to the SET-UP MENU display.

Gauge mode

The Gauge mode provides additional gauge displays. A voltage display is standard. Engine oil temperature and transmission oil temperature displays are optional and are enabled by End-of-Line programming. Gauge displays contain a symbol and a value (such as volts or degrees), and text messages when appropriate.



W3000712

Gauge displays

Note: When a condition requiring attention occurs, the symbol identifying that condition will automatically replace the current gauge display.

To choose a gauge display:

- 1 Press the Mode button until a gauge display appears.
- 2 Use the Up and Down buttons to display the desired gauge:
 - **Voltmeter** - This standard gauge display monitors the battery voltage. If the voltage exceeds 16 volts, TOO HIGH will be displayed.
 - **Engine Oil Temperature** - The range of this optional gauge display is 90° to 310° F. If the temperature exceeds the trip point, TOO HIGH will be displayed and the yellow Caution telltale will light.
 - **Transmission Oil Temperature** - This optional gauge display monitors the transmission oil temperature. Its range is 90° to 310° F. If the temperature exceeds the trip point, HIGH will be displayed and the yellow Caution telltale will light.

Preset trip points for Graphic Display gauges

Each of the gauges in the Graphic Display has a preset trip point. A trip point represents a critical condition when reached. The Engine Oil Temperature gauge display may have a trip point of 270° F, for example. Should a trip point be reached, the Graphic Display will automatically replace the current gauge display (or any other display, for that matter) with a symbol or message identifying the critical condition.

Trip points for clusters to be used with Volvo engines are preset at the factory during End-of-Line programming. When the cluster is installed with a Caterpillar, Cummins, or Detroit Diesel engine, the trip points are sent via the J1587 data link according to each manufacturer's specifications. Refer to the appropriate manual for these trip points.

In some cases, the yellow Caution telltale or red Stop telltale may also light, and the buzzer may also sound

when a trip point is reached. These warnings will continue until the ignition is turned off or until the condition causing the warning no longer exists. The visual and audible warnings will return if the condition that caused the warning still exists when the ignition is turned back on.

The Engine Oil Temperature gauge in Volvo applications uses an analog sensor. In other applications, this gauge receives its display data from the engine electronic control unit. These trip points are set to the engine manufacturer's specifications.

Fuel Economy mode

The Fuel Economy mode allows the driver to see his fuel economy during a trip. Information is updated continually and is presented in the form of a bargraph. Average fuel economy during the trip (AVG), and the fuel economy under the current conditions (INST) can be seen at a glance, along with the fuel economy target value (set using the Set-Up menu).

The Fuel Economy mode contains a Avg/Inst/Target display and a Trip Fuel Meter display function. To select one of these displays:

- 1 Use the Mode button to select the Fuel Economy display.
- 2 Use the Up and Down buttons to display the bargraph or TRIP FUEL METER.

Avg/Inst/Target Display

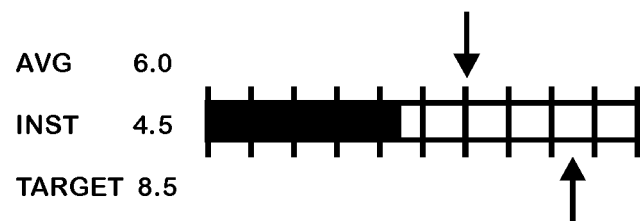

W3000713

The Avg/Inst/Target Display shows the vehicle's average, instantaneous, and target fuel economy. The range is 0 to 99.9 miles per gallon, or 0 to 999 liters per 100 kilometers (selectable using the Set-Up menu). The data is calculated by the microprocessor on the Left Circuit Board using inputs from the J1587 data link. The AVG value can be reset by pressing the Set button while in this display (the Trip Fuel Meter value will also be reset).

Trip Fuel Meter

The Trip Fuel meter displays the amount of fuel used since the last time it was reset. Its range is from 0 to 9999 gallons or liters (driver selectable), and the data is calculated by the microprocessor on the Left Circuit Board using inputs from the J1587 data link. The Trip Fuel value can be reset to zero by pressing the Set button while in this display (the AVG fuel economy value will also be reset).

Center section

Tachometer

The tachometer is an electrical aircore meter movement driven by signals from the J1587 data link. In the absence of data link information, the gauge pointer will move to its minimum reading after a 3–5 second delay.

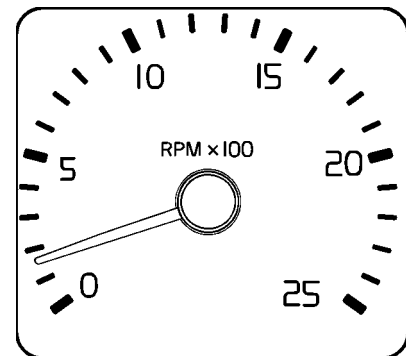

W3000843

Speedometer and odometer

The speedometer is an electrical aircore meter movement driven by signals from the J1587 data link. In the absence of data link information, the gauge pointer will move to its minimum reading after a 3–5 second delay. Note that the cluster does not perform speedometer calibration. Speedometer calibration to compensate for tire sizes and other driveline changes is done during programming of the engine or transmission ECU.

The Odometer is a Liquid Crystal Display (LCD) mounted behind the speedometer dial. It has a full scale reading of 999999.9. Odometer information is calculated from road speed via the J1587 data link and is stored in the cluster's microprocessor. The odometer backlighting can be adjusted independently of gauge backlighting.

During normal operation, the odometer display goes blank 30 seconds after the ignition is switched off. To reactivate the display, turn the ignition on, or the odometer display can be reactivated by pressing any of the buttons.

In the absence of speedometer data, the odometer display will not change and the speedometer pointer will remain at zero.

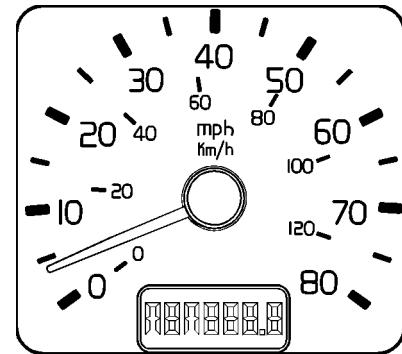

W3000844

Telltale lamps, center section

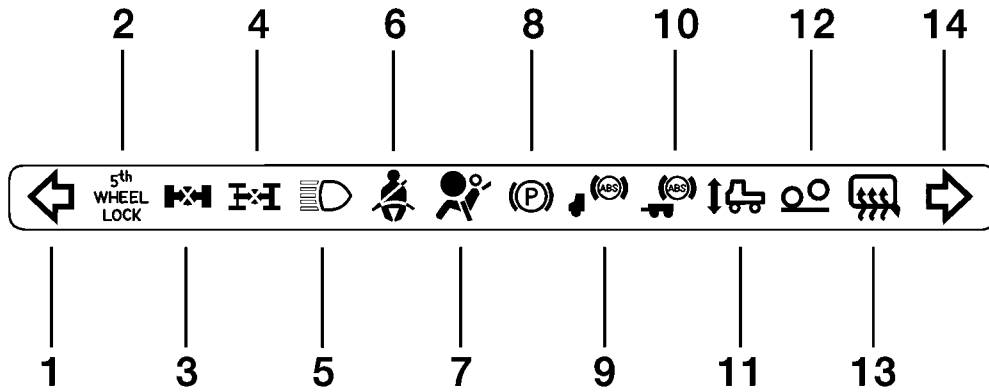

W3000840

- | | |
|---|---|
| <ul style="list-style-type: none"> 1 Left Turn Indicator 2 5th Wheel Lock Indicator 3 Wheel Differential Lock Indicator 4 Interaxle Differential Lock Indicator 5 High Beam Indicator 6 Safety Belt Indicator 7 SRS (Airbag) Indicator | <ul style="list-style-type: none"> 8 Parking Brake Indicator 9 Anti-Lock Brake System (Tractor) Indicator 10 Anti-Lock Brake System (Trailer) Indicator 11 Air Suspension System Indicator 12 Bogie Lift Indicator 13 Mirror Defroster Indicator 14 Right Turn Indicator |
|---|---|

Note that all gauges and telltales may not be used in all vehicles.

Master Warning telltale

A red Master Warning telltale consisting of an exclamation point (!) inside a triangle is located near the bottom and midway between the tachometer and the speedometer. It lights when the front or rear brake air pressure is too low for safe operation (below 72 psi).



W3000638

Right section

Forward and rear drive axle temperature (optional)

The forward and rear axle temperature gauges are electrical aircore meter movements. They are connected to temperature sender units mounted on the axle housings. The higher the temperature, the lower the resistance of the sender unit, and the farther the gauge pointer moves to the right.

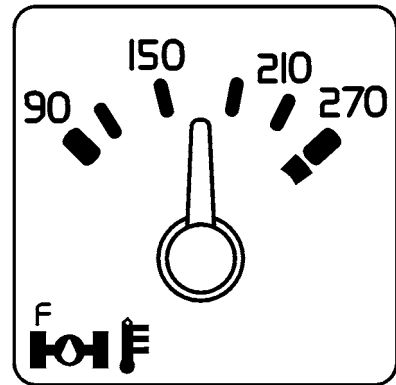

W3000984

Forward Axle Temperature Gauge

Fuel level

The fuel level gauge is an electrical aircore meter movement that receives its signal from a sensor in the fuel tank.

The fuel level sensor signal is input to the cluster microprocessor through the left module connector. In the microprocessor the signal is changed from a resistance to a pulse width modulated signal. It is then sent to the right module via jumper IPJ5. As the duty cycle of the signal increases, the level shown on the gauge increases.

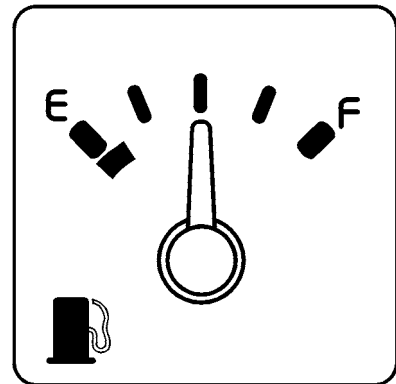

W3000814

Application air pressure (optional)

The application air pressure gauge is a mechanical gauge. It is attached to the service brake system by a hose going into a quick-disconnect fitting on the rear of the gauge. It reads applied air pressure to the service brake system. The air hoses and quick-disconnects are color-coded to avoid wrong connections.

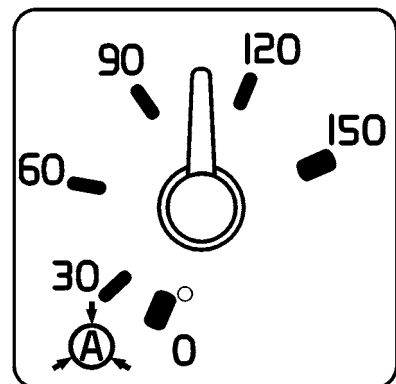

W3000608

Front and rear brake air pressure

The air pressure gauges are mechanical gauges. They are attached to their air systems by a hose going into a quick-disconnect fitting on the rear of the gauge. The air hoses and quick-disconnects are color-coded to avoid wrong connections.

The front and rear brake air pressure gauges contain mechanical contacts. When the air pressure drops below a preset value, the contacts close, causing a warning buzzer to sound and a red warning LED in the lower right corner of the gauge to light. The Master Warning indicator will also light.

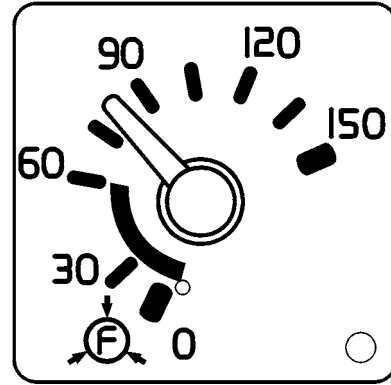

W3000609

Front Brake Air Pressure Gauge

Telltale lamps, right section

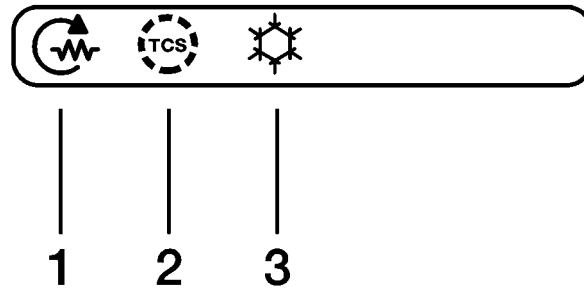

W3000841

- 1 Pre-heat
- 2 Traction Control System
- 3 APADS (Air Conditioning Protection and Diagnostic System — for future use)

Note that all gauges and telltales may not be used in all vehicles.

Buzzer signals

The buzzer is part of the cluster and has the following distinct signals:

- **Turn signal** - Single short beep in time with the Turn Indicator telltales.
- **Clock reminder** - A double beep every other second. This is activated by the alarm clock function in the Graphic Display and works whether the ignition is on or off. The clock reminder will override a Turn signal buzzer.
- **Warning signal** - Two beeps every second. This is activated when any red telltale except No Charge and Park Brake are on and the engine is running faster than 300 rpm (idle). The Warning signal will override all other signals.

While in the cluster self test or diagnostic mode the buzzers do not sound.

Connector pinouts

LX and LY connectors

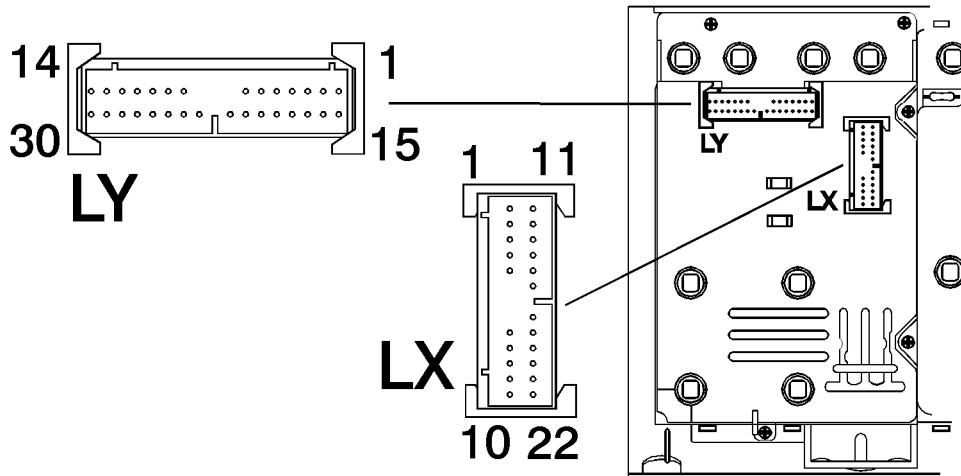

W3000849

Left Module, LX Connector			
Pin	Description	Circuit No.	Input
1	Data Link + (J1587)	400	mV reading
2	Fuel Sensor	183	33-250 ohms
3	Fuel Level (Jumper to Right Module)	IPJ5	Pulse width modulated signal (5V)
9	Battery -	0X-1	Ground
10	Battery +	202	+12 V
11	Data Link - (J1587)	401	mV reading
12	Power Ground	0P-1	Ground
20	Illumination +	141-J	0-12 V
22	Ignition +	180	+12 V

Pins not listed are not used.

Note: All resistance measurements must be made with power removed from the circuit.

Left Module, LY Connector			
Pin	Description	Circuit No.	Input
1	Air Filter Restriction Gauge	199	Ground (when activated)
3	Bulb Test + (Output) (Jumper to Center Module)	IPJ1	+12V during bulb test
4	Bulb Test - (Output) (Jumper to Center Module)	IPJ2	Ground during bulb test
5	No Charge Warning Lamp	14	Ground (Note 1)
6	Stop Engine Warning Lamp (Caterpillar, Cummins and Detroit Diesel engines only. Volvo is not hardwired.)	575	Ground
10	Caution Lamp	576	Ground (Note 2)
11	Engine Fluids Warning Lamp (Volvo and Cummins engines only)	577	Ground
13	Pyrometer -	190	Ground
15	+ 5V Output (Reference Jumper to Right Module)	IPJ3	+5V
16	Return to Zero (Jumper to Right Module)	IPJ4	Ground
19	End Of Line Programming Enable	403A	Ground (used only when programming)
23	Washer Fluid Level	387A	Ground (when activated)
27	Engine Oil Temperature (Volvo engine only)	204	Sensor Input
28	Transmission Oil Temperature	314	Sensor Input
30	Pyrometer +	191	0-100 mV

Pins not listed are not used.

All resistance measurements must be made with power removed from the circuit.

Note 1: The No Charge Warning Lamp will begin to illuminate dimly when the engine is running and the input on this pin drops below 12 V. It will illuminate fully when it drops below 8 V.

Note 2: The Caution lamp illuminates when engine RPM is above 500, and there is a fault in the graphic display for Engine Oil Temperature, Transmission Oil Temperature, or Voltage. The Caution lamp will also illuminate if other engine ECU fault codes instruct the lamp to illuminate.

CY connector

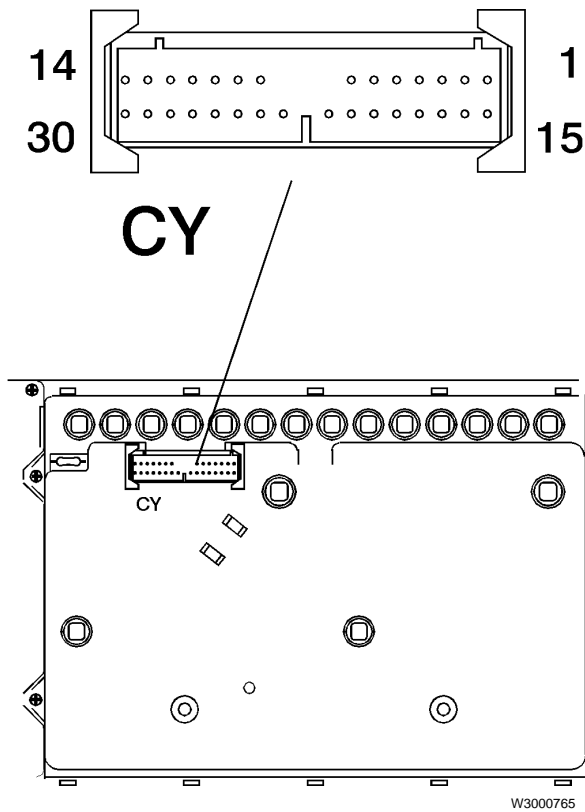

Center Module, CY Connector			
Pin	Description	Circuit No.	Input
1	ABS, Truck	779	Ground
3	Park Brake	420	Ground
4	Heated Mirror	702	+12V
5	Bulb Test + (from LY-3)	IPJ1	
6	Bulb Test - (from LY-4)	IPJ2	
8	High Beam	33	+12V
9	Right Turn Indicator	113	+12V
10	Interaxle Differential Lock	422	+12V
11	Power Ground	0P-3	Ground
12	Interwheel Differential Lock	426	Ground
13	Fifth Wheel Lock	424	Ground
14	Left Turn Indicator	112	+12V
15	Air Suspension Pressure	431	Ground
18	Backlighting	141-H	0-12V
19	Bulb Test + (to Right Module)	IPJ6	
20	Bulb Test - (to Right Module)	IPJ7	
22	Ignition +	180	+12V
24	SRS (Airbag) Warning	0X-3	Ground (Needs open circuit to turn on)
25	Master Warning (from Right Module)	IPJ8	Ground

Pins not listed are not used.

All resistance measurements must be made with power removed from the circuit.

RX connector

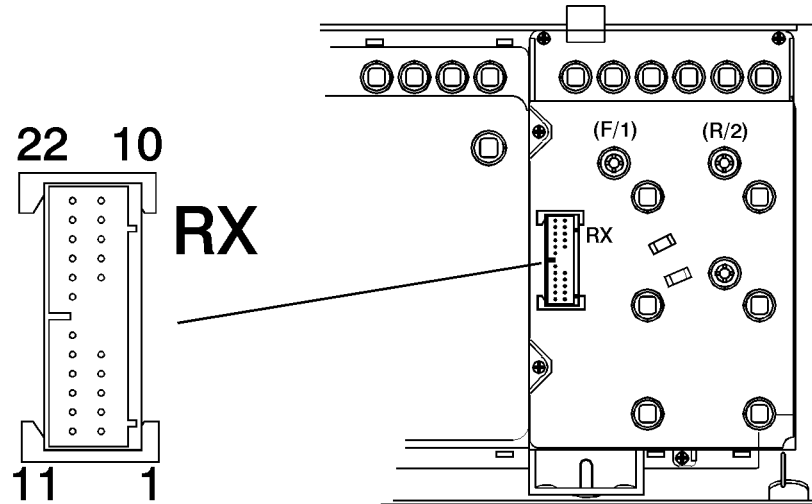

W3000847

Right Module, RX Connector			
Pin	Description	Circuit No.	Input
1	Illumination +	141-G	0-12 V
2	Ground	0X-2	Ground
3	Rear Axle Temperature (Front)	468	Variable resistance (Note 1)
4	Fuel Level (Jumper from LX-3, Left Module)	IPJ5	Pulse width modulated signal
7	Master Warning output (Jumper to Center Module)	IPJ8	Ground
11	Power Ground	0P-4	Ground
12	+5V (Jumper from LY-15, Left Module)	IPJ3	+5 V
13	Rear Axle Temperature (Rear)	469	Variable resistance (Note 1)
14	Ignition +	180	+12V
15	Return to Zero (Jumper from LY-16, Left Module)	IPJ4	Ground
18	Bulb Test + (Input) (Jumper from Center Module)	IPJ6	+12V during bulb test
19	Bulb Test - (Input) (Jumper from Center Module)	IPJ7	Ground during bulb test
20	Engine Preheat (Volvo engine only)	361	Ground
21	Traction Control System	774-B (Bendix) 774-A (Wabco)	Ground

Pins not listed are not used.

All resistance measurements must be made with power removed from the circuit.

Note 1: Axle temperature measurements must be made with the RX connector disconnected.

Troubleshooting

This chapter describes how to test the instrument cluster and troubleshoot the cluster as a whole.

General service information

Many of the components can be tested without disturbing the cluster by using the Cluster Self Test Mode function in the Graphic Display's Diagnostics Menu. This includes all telltale lamps, the speedometer, tachometer, oil pressure gauge, coolant temperature gauge and Graphic Display unit. The pivot-down mounting feature of the cluster allows troubleshooting of input signals without removing the cluster from the vehicle.

Storing the cluster

CAUTION

When servicing or troubleshooting, do not leave the cluster face-down for more than 15 minutes, or damage to the gauges may occur. Gauge oil can run out the front of the gauge faces and make the gauges inaccurate.

The electrical gauges contain an oil that can start to run out if the gauge is left upside down longer than 15 minutes. If the oil runs out, the gauge becomes inaccurate. For this reason, always store clusters and gauges face-up.

Tools and test equipment

For the procedures described in this chapter, you will need the following tools:

- T25 Torx head driver (cluster mounting screws).
- Telltale lamp removal tool (Volvo P/N 1608077)
- Digital multi-meter which can measure down to 5 millivolts

Hose connections to the air pressure gauges are quick-disconnect and the air hoses to them can be disconnected and reconnected without tools.

DANGER

Never disconnect an air system component unless all system pressure has been depleted. Failure to deplete system pressure before disconnecting hoses or components may result in them separating violently and causing serious bodily injury.

Troubleshooting individual gauges

Cluster backlighting

The cluster backlighting receives power from a dimmer control located on the vehicle dash. The backlighting is brightest when the control provides +12 volts, and grows dimmer as the voltage drops toward zero. The cluster backlighting is independent of the odometer and Graphic Display backlighting.

Testing the cluster backlighting

To test the cluster backlighting, turn the dash lights on and adjust the dimmer control for maximum brightness.

- 1 If none of the backlights light, check for +12 volts at the output of the dimmer control on the vehicle dash.
 - a. If present, replace the cluster.
 - b. If not present, there could be a short in the cluster. One at a time, unplug each cluster connector and recheck for +12 volts. If present, replace the cluster; if not, check the input to the dimmer control and the fuse.
- 2 If only the right, center or left section of the cluster has no backlighting, check the input pin for +12 volts.

Left Section	pin LX-20
Center Section	pin CY-18
Right Section	pin RX-1

 - a. If present, replace the cluster.
 - b. If not present, check the input to the control and the fuse.
- 3 If only one bulb of a particular board is affected, replace the lamp/socket assembly as described in Service Procedures in this manual. If the problem persists, replace the cluster.

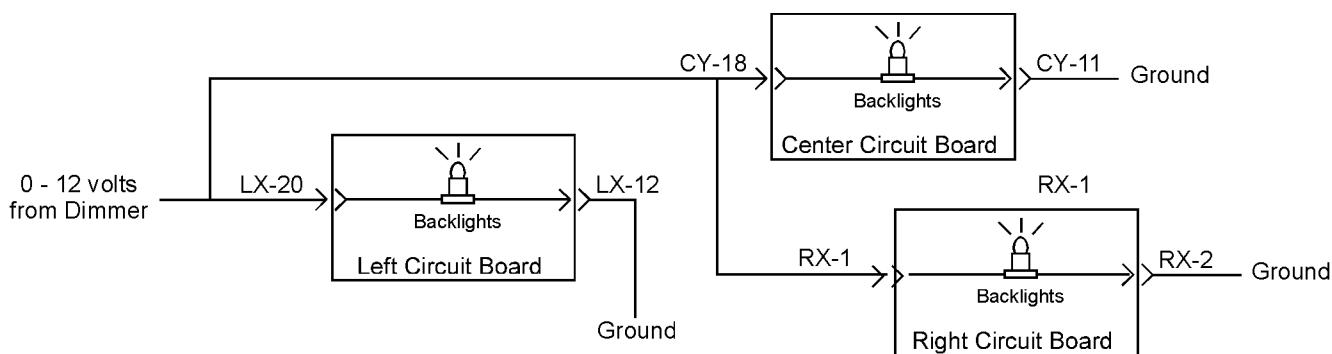

Cluster backlighting signal flow

W3000716

Odometer and graphic display backlighting

Odometer and Graphic Display backlighting is independent of the rest of the cluster. Test the odometer and Graphic Display backlighting as follows:

- 1 Use the Backlighting Adjust function in the Set-Up Menu to set the odometer and Graphic Display backlighting to maximum brightness.
 - 2 If neither the Graphic Display nor the odometer backlighting work, or if the backlighting will not dim, replace the cluster.

Buzzer problems

The buzzer can be tested by performing the Buzzer Test in the Cluster Self Test Mode of the Diagnostics Menu.

The buzzer is not serviceable. If it fails to sound, replace the cluster.

Buzzer Signal
Turn signal beep (momentary beep)
Clock reminder (double beep every other second)
Warning signal (two beeps every second)

Telltale indicators

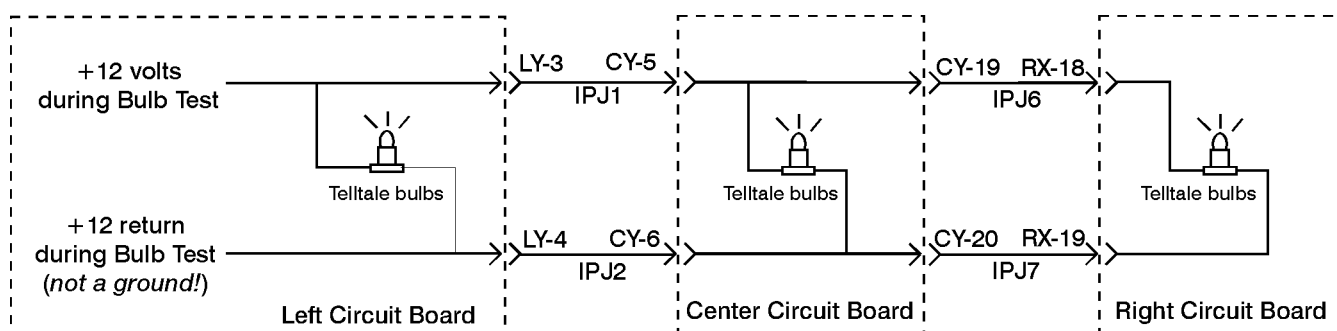

Telltale bulb signal flow

W3000986

Telltale indicators are lighted by bulbs positioned across the bottom of the instrument cluster.

Testing the telltale bulbs

Test the telltale bulbs by using the Bulb Test function in the Cluster Self Test Mode of the Diagnostics menu.

1

 CAUTION
<p>When probing connector terminals, do not insert probes into the terminals. This will spread the terminals apart, causing permanent damage. Probe the insertion side of the connector.</p>

If none of the telltale bulbs light during the Bulb Test function, check for +12 volts between LY-3 and LY-4 during the Bulb Test function. If missing, replace the cluster.

- 2 If the suspect bulb lights during the self test, the problem is not in the cluster. Check the signal source for individual telltale bulbs.
- 3 If the suspect bulb fails but other bulbs light during the self test, replace the suspect bulb.
- 4 If none of the bulbs in the center section light during the Bulb Test function, check for +12 volts between CY-5 and CY-6, or between CY-19 and CY-20. If missing, there is an open wire in the wiring harness.
- 5 If none of the bulbs in the right section light during the Bulb Test function, check for +12 volts between RX-18 and RX-19. If missing, there is an open wire in the wiring harness.

For more information, refer to the *VNL, VNM Electrical Schematics*.

Left section

Pyrometer gauge

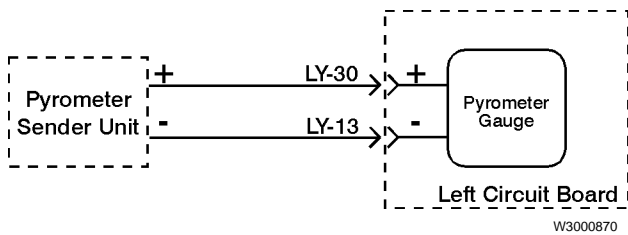

Pyrometer gauge signal flow

If the pyrometer thermocouple fails, the pointer will move to one end of the dial or the other. A reading of 300° F or less indicates an open in the truck's wiring or thermocouple, and a reading of 1500° F or more indicates a short.

If the Pyrometer gauge fails to indicate within 100° F of a known true value, check the thermocouple and wiring with a digital voltmeter capable of reading down to 5 millivolts.

- 1 Make certain the vehicle ignition is **OFF**.

2

CAUTION

When servicing or troubleshooting, do not leave the cluster face-down for more than 15 minutes, or damage to the gauges may occur. Gauge oil can run out the front of the gauge faces and make the gauges inaccurate.

CAUTION

When probing connector terminals, do not insert probes into the terminals. This will spread the terminals apart, causing permanent damage. Probe the insertion side of the connector.

Gain access to the back of the cluster. With the ignition on, there should be 5 to 50 millivolts between connector LY pins 30 and 13.

- a. If the voltage is incorrect, replace the thermocouple or the wire to it.
- b. If the voltage is correct, replace the cluster.

Engine oil pressure gauge

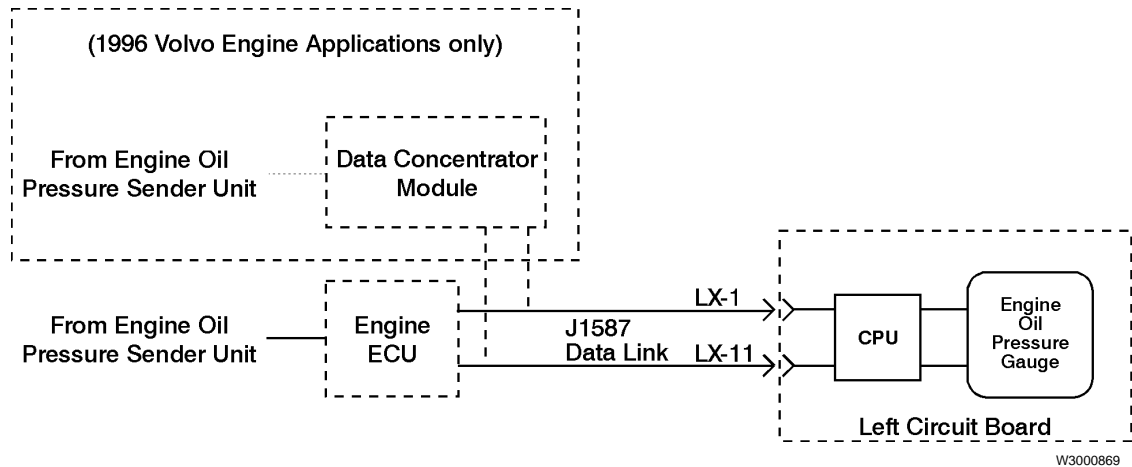

Engine Oil Pressure gauge signal flow

In the absence of an engine oil pressure data signal, the gauge pointer will move to its minimum reading after a 3–5 second delay.

If the pointers on *all the gauges* on the J1587 data bus move to the minimum reading, there is a problem in the data link circuit. Troubleshoot the 400/401 wiring and connectors.

Intermittent function

- If this and other gauges on the J1587 data link appear to “twitch” or function intermittently, check the 400/401 circuit for a loose connection.
- If *this gauge only* appears to function intermittently, the data link could be overloaded with data from ECUs in the vehicle system. In this case, check the data link using the MPSI Pro-Link Snapshot function.

Incorrect gauge reading

If the gauge does not appear to indicate the correct engine oil pressure, test it using the Gauge Test function in the Cluster Self Test Mode of the Diagnostics Menu:

- 1 If the gauge pointer sweeps back and forth across the full range, the meter movement and its associated circuitry in the cluster are working. Use the Diagnostic Messages function of the Diagnostics Menu to check for oil pressure related messages. Use the service tool for the engine in your vehicle to compare any diagnostic messages shown in the instrument cluster.
- 2 If a sensor problem is indicated, check the wiring from the sensor for opens or shorts, according to the engine manufacturer’s service literature. Also refer to the *VNL, VNM Electrical Schematics* for wiring information.
- 3 If the pointer fails to sweep, and a sensor problem has been ruled out replace the cluster.

Engine coolant temperature gauge

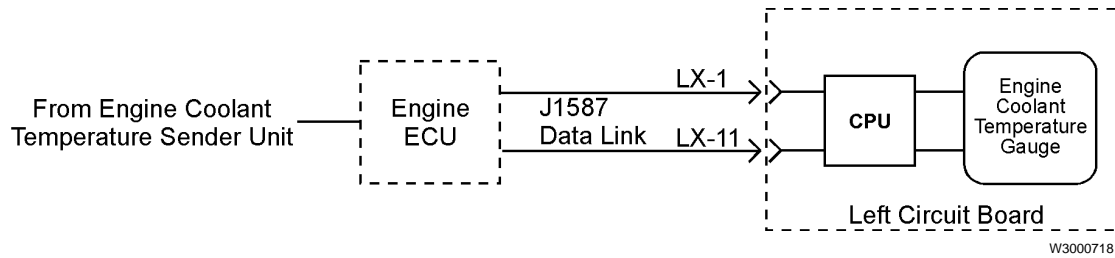

Coolant temperature gauge signal flow

The coolant temperature gauge is an electrical aircore meter movement which receives its signal from the engine via the J1587 data bus. In the absence of a data signal, the gauge pointer will move to its minimum reading after a 3–5 second delay.

If the pointers on *all the gauges* on the J1587 data bus move to the minimum reading, there is a problem in the data link circuit. Troubleshoot the 400/401 wiring and connectors.

Intermittent function

- If this and other gauges on the J1587 data link appear to “twitch” or function intermittently, check the 400/401 circuit for a loose connection.
- If *this gauge only* appears to function intermittently, the data link could be overloaded with data from ECUs in the vehicle system. In this case, check the data link using the MPSI Pro-Link Snapshot function.

Incorrect gauge reading

The gauge can be tested by activating the Cluster Self Test Mode function of the Diagnostics Menu.

- 1 If the gauge pointer sweeps back and forth across the full range, the gauge and its associated circuitry in the cluster are working.
 - a. Check for coolant-related messages using the Diagnostic Messages function of the Diagnostics Menu. Use the service tool for the engine in your vehicle to compare any diagnostic messages shown in the instrument cluster.
 - b. If a sensor problem is indicated, check the wiring from the sensor for opens or shorts, according to the engine manufacturer's service literature. Also refer to the *VNL, VNM Electrical Schematics* for wiring information.
- 2 If the gauge pointer does not move during the self test, and a sensor problem has been ruled out, replace the cluster.

Turbo boost pressure gauge

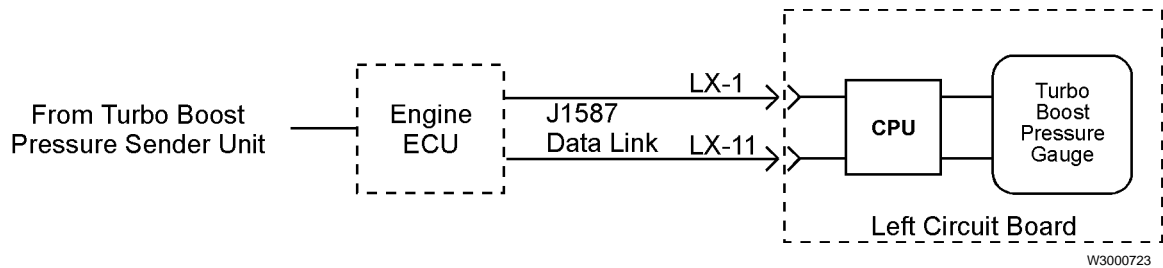

Turbo Boost Pressure gauge signal flow

The Turbo Boost Pressure gauge is an electrical aircore meter movement which receives its signal from the engine via the J1587 data bus. In the absence of a data signal, the gauge pointer will move to its minimum reading after a 3–5 second delay. If Turbo Boost Pressure data is missing during normal operating conditions, the Turbo Boost Pressure gauge pointer will move to the low end of the scale (zero pressure).

If the pointers on *all the gauges* on the J1587 data bus move to the minimum reading, there is a problem in the data link circuit. Troubleshoot the 400/401 wiring and connectors.

Intermittent function

- If this and other gauges on the J1587 data link appear to “twitch” or function intermittently, check the 400/401 circuit for a loose connection.
- If *this gauge only* appears to function intermittently, the data link could be overloaded with data from ECUs in the vehicle system. In this case, check the data link using the MPSI Pro-Link Snapshot function.

Incorrect gauge reading

To test the gauge:

- 1 Check for messages using the Diagnostic Messages function of the Diagnostics Menu. Use the engine service tool to compare any diagnostic messages shown in the instrument cluster. If a sensor problem is indicated, check the wiring from the sensor for opens or shorts, according to the engine manufacturer’s service literature. Also refer to the *VNL, VNM Electrical Schematics* for wiring information.
- 2 Use the Gauge Test function in the Cluster Self Test Mode of the Diagnostics Menu.
 - a. If the Turbo Boost Pressure gauge pointer sweeps back and forth across its full range, its meter movement and associated circuitry in the cluster are working.
 - b. If the gauge pointer does not move during the self test, and a sensor problem has been ruled out, replace the cluster.

Graphic Display

Use the Display Test function in the Cluster Self Test Mode of the Diagnostics Menu to test the graphic display. If the display is defective, replace the instrument cluster.

During the Display Test, all pixels in the display will alternate from dark to light 2 times.



W3000719

Check for missing pixels, and for pixels that are always dark. If defective, replace the cluster.

Center section

Speedometer, odometer and tachometer

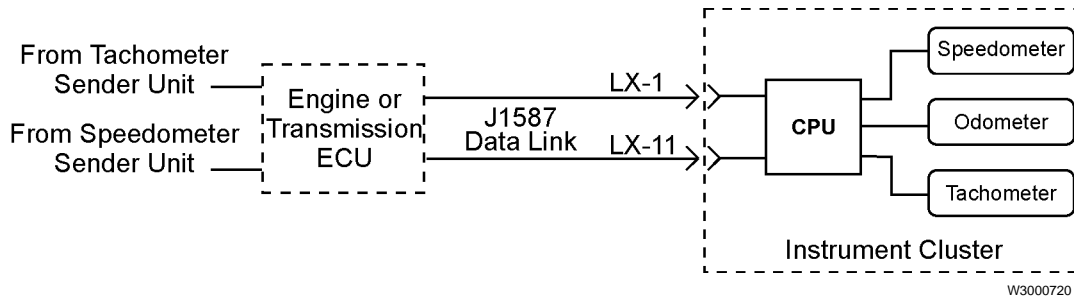

Speedometer/Odometer/Tachometer signal flow

Speedometer

The speedometer gauge is an electrical aircore meter movement which receives its signal from the engine via the J1587 data bus. In the absence of a data signal, the gauge pointer will move to its minimum reading after a 3–5 second delay.

If the pointers on *all the gauges* on the J1587 data bus move to the minimum reading, there is a problem in the data link circuit. Troubleshoot the 400/401 wiring and connectors.

Intermittent function

- If this and other gauges on the J1587 data link appear to “twitch” or function intermittently, check the 400/401 circuit for a loose connection.
- If *this gauge only* appears to function intermittently, the data link could be overloaded with data from ECUs in the vehicle system. In this case, check the data link using the MPSI Pro-Link Snapshot function.

Incorrect gauge reading

If the speedometer accuracy is off more than 10%, check the calibration of the engine ECU. Compare the results of the ECU calibration with readings obtained with the diagnostic service tool recommended by the engine manufacturer.

Each engine manufacturer formats calibration differently. For the Volvo engine only, the engine ECU calibrates the speedometer with the following formula:

$$\text{pulses/mile} = (\text{tire rev/mile}) \times (\text{rear axle ratio}) \times (\text{no. of teeth on chopper wheel on transmission})$$

for example, pulses/mile = 501 rev/mi x 4.10 x 16 pulses/rev = 32866 pulses/mile.

Test the speedometer by using the Gauge Test function in the Cluster Self Test Mode of the Diagnostics Menu. Use the service tool for the engine in your vehicle to compare any diagnostic messages shown in the instrument cluster. If a sensor problem is indicated, check the wiring from the sensor for opens or shorts, according to the engine manufacturer’s service literature. Also refer to the *VNL, VNM Electrical Schematics* for wiring information.

If the speedometer pointer sweeps back and forth across its full range, its meter movement and associated circuitry within the cluster are working. If the gauge pointer does not move during the self test, and a sensor problem has been ruled out, replace the cluster.

Odometer

During normal operation, the odometer display remains on for 30 seconds after the ignition is switched off. To reactivate the display, turn the ignition on.

In the absence of speedometer data, the odometer display will not change and the speedometer pointer will remain at zero.

- If there is a problem with the odometer but the speedometer works, replace the cluster.
- If the odometer is inaccurate, check the engine ECU speed calibration. If correct, replace the cluster.

Tachometer

In the absence of data link information, the tachometer gauge pointer will move to its minimum reading after a 3–5 second delay.

If the pointers on *all the gauges* on the J1587 data bus move to the minimum reading, there is a problem in the data link circuit. Troubleshoot the 400/401 wiring and connectors.

Intermittent function

- If this and other gauges on the J1587 data link appear to “twitch” or function intermittently, check the 400/401 circuit for a loose connection.
- If *this gauge only* appears to function intermittently, the data link could be overloaded with data from ECUs in the vehicle system. In this case, check the data link using the MPSI Pro-Link Snapshot function.

Incorrect gauge reading

Test the tachometer by using the Gauge Test function in the Cluster Self Test Mode function of the Diagnostics Menu. Use the service tool for the engine in your vehicle to compare any diagnostic messages shown in the instrument cluster. If a sensor problem is indicated, check the wiring from the sensor for opens or shorts, according to the engine manufacturer’s service literature. Also refer to the *VNL, VNM Electrical Schematics* for wiring information.

If the tachometer pointer sweeps back and forth across its full range, its meter movement and associated circuitry within the cluster are working. If the gauge pointer does not move during the self test, and a sensor problem has been ruled out, replace the cluster.

Right section

Axle temperature gauges (forward and rear)

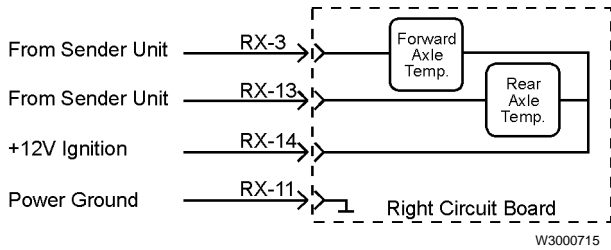

Front and Rear Drive Axle Temperature gauge signal flow

Fault indications

A constant gauge reading of 90° F or less can be caused by a defective sender unit or gauge, or an open wire between the cluster and the sender unit.

A constant reading of 270° F or more can be caused by a defective gauge or sender unit, or by a wire that is shorted to ground between the gauge and the sender unit.

Inaccuracies greater than 10° F usually indicate a defective sender unit or gauge.

Testing the axle temperature gauges

1 Make certain the vehicle ignition is **OFF**.

2

CAUTION

When servicing or troubleshooting, do not leave the cluster face-down for more than 15 minutes, or damage to the gauges may occur. Gauge oil can run out the front of the gauge faces and make the gauges inaccurate.

CAUTION

When probing connector terminals, do not insert probes into the terminals. This will spread the terminals apart, causing permanent damage. Probe the insertion side of the connector.

Gain access to the rear of the instrument cluster. Disconnect connector RX and measure the resistance between harness pin 13 (Front Axle gauge) or pin 3 (Rear Axle gauge), and pin 11 (ground):

Axle Temp.	Expected Reading
70° F	1000 ohms \pm 10%
120° F	430 ohms \pm 10%
200° F	110 ohms \pm 10%

3 If the resistance readings are correct, reconnect the connectors and turn the key on. There should be battery voltage between connector RX pins 11 and 14. If not, and the rest of the cluster works, the wire from RX-14 is probably open.

4 If the readings are off more than 10%, the sender unit should be checked. The sender is mounted on the axle. Refer to the *VNL, VNM Electrical Schematics* for wiring information.

Air pressure gauges

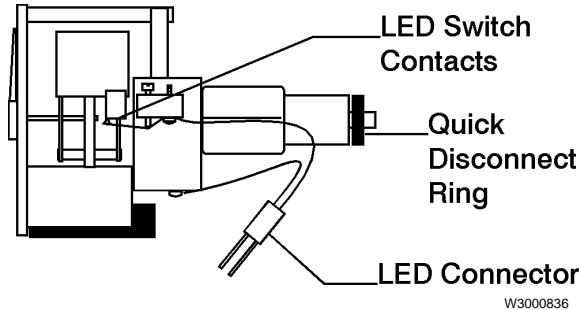

Note: The LED connector wires are not polarity-sensitive.

Inaccurate or erratic gauge readings are usually caused by dirt or other contamination in the gauge. The gauges and their warning LEDs can be tested as shown.

DANGER

Never disconnect an air system component unless all system pressure has been depleted. Failure to deplete system pressure before disconnecting hoses or components may result in them separating violently and causing serious bodily injury.

Air Gauge Test:

- 1 Drain the air pressure from both air systems.
- 2

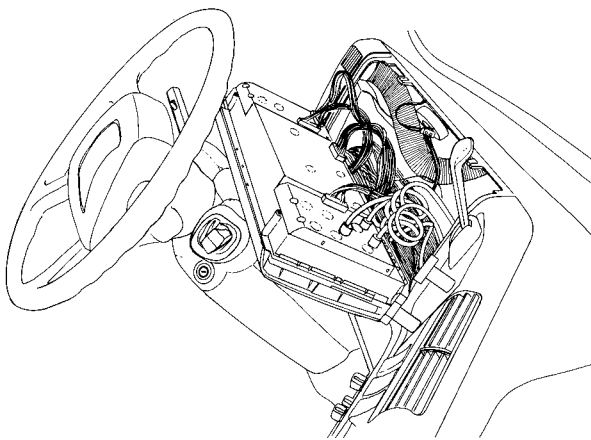

Remove the two screws at the top of the instrument cluster and lay the cluster face-down on the steering column.

3

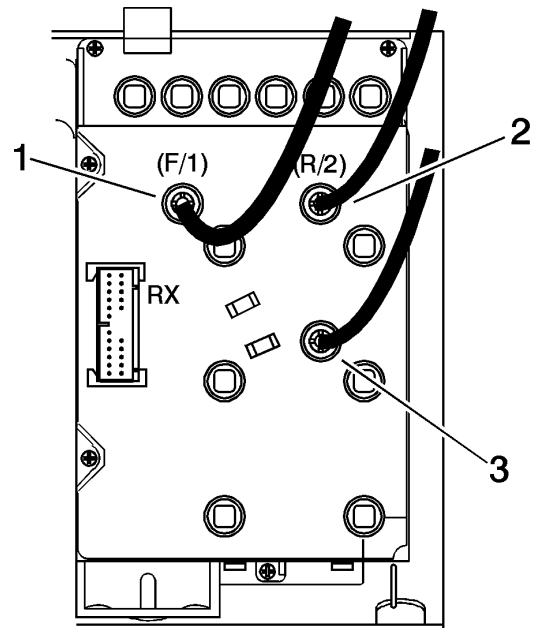

- 1) Rear Brake Pressure Air Line (Red)
- 2) Front Brake Pressure Air Line (Green)
- 3) Application Air Pressure Air Line (Black)

Remove the air lines from the Front and Rear Brake Air Pressure gauges.

- 4 Connect the air lines back into the opposite gauges, start the engine and build the air pressure in the systems.
- 5 Compare the sweep of both gauges to see if the problem still exists, or if the problem is now in the other gauge. If the problem is in the other gauge, troubleshoot the air line for a kink or restriction.
- 6 If the problem still exists in the same gauge, replace the cluster.

Air Gauge LED Test

- 1 To test the red warning LED in the Front or Rear Brake Air Pressure gauge, pump the brake pedal while the ignition is on (and engine is off) to lower the system air pressure. When the pressure drops below 60 psi, the LED must light. If not, check the LED circuitry by using the Bulb Test function. If the LED does not light during the Bulb Test, replace the cluster.
- 2 Start the engine. When the air pressure rises above 70 ±10 psi, the LED should turn off. If not, replace the cluster.

Fuel Level gauge

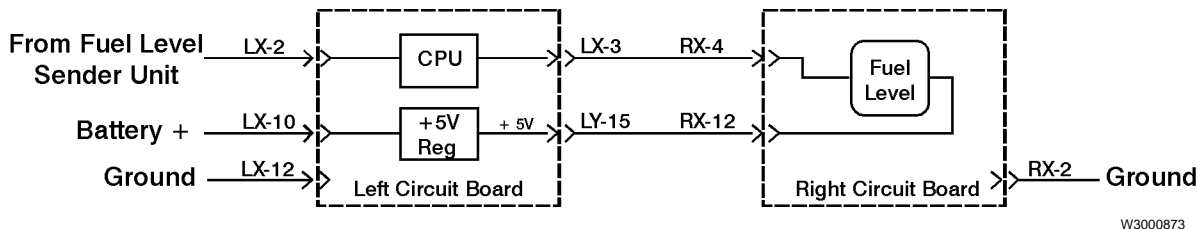

Fuel level gauge signal flow

The Fuel Gauge is an electrical aircore meter movement that receives its signal from a sensor in the fuel tank. This signal is input to the microprocessor on the instrument cluster, which drives the gauge.

If the fuel gauge is reading incorrectly, it can be tested by activating the Cluster Self Test Mode function of the Diagnostics Menu:

- **If the pointer sweeps** back and forth across its full range during the cluster self test, the meter and its associated circuitry in the cluster are working. Go to step 1 below.
- **If the pointer does not sweep during the cluster self test**, the most likely cause is a defective Fuel Level gauge, or a wiring problem in the harness. Go to step 4.
- **If the pointer does not sweep during the cluster self test AND the pointer:**

falls below the empty mark
or constantly stays on the Full mark
or constantly stays on the 1/2 mark

Go to step 6.

- 1 Make certain the vehicle ignition is **OFF**.
- 2 If gauge failure is suspected, check for mechanical failure of the fuel level sender. If the sender is in good physical condition, disconnect the connector and measure resistance at the fuel level sender. The reading should be between 33 and 240 ohms depending upon the fuel level in the tank (see Table A).
 - If resistance is as shown in Table A, reconnect the sender connector and proceed to step 3.
 - If resistance is not as shown in Table A, replace the fuel level sender.

Fuel Level	Expected Reading (at sender and LX-2 to LX-12)
Empty tank	240 ohms ±10%
1/4 tank	153 ohms ±10%
1/2 tank	103 ohms ±10%
3/4 tank	67 ohms ±10%
Full tank	33 ohms ±10%

3

CAUTION

When servicing or troubleshooting, do not leave the cluster face-down for more than 15 minutes, or damage to the gauges may occur. Gauge oil can run out the front of the gauge faces and make the gauges inaccurate.

CAUTION

When probing connector terminals, do not insert probes into the terminals. This will spread the terminals apart, causing permanent damage. Probe the insertion side of the connector.

Gain access to the back of the instrument cluster. Disconnect connector LX and use an ohmmeter to measure the resistance between pins 2 and 12 on the harness connector (insertion side). The reading should be between 33 and 240 ohms depending upon the fuel level in the tank (see Table A for values).

- If resistance is as shown in Table A, go to step 4.
- If resistance is not as shown in Table A, check the connectors and wiring from the LX connector to the fuel level sender. Refer to the *VNL, VNM Electrical Schematics* for wiring information.

- 4 Turn the ignition *ON* and use a voltmeter to measure the voltage between pins 2 and 4 on the RX connector. Measurements should be as follows:

Table B: Voltage Check	
Fuel Level	Expected Reading (RX-2 to RX-4 and RX-2 to LX-3)
Empty tank	0.19 volts \pm 10%
1/4 tank	1.1 volts \pm 10%
1/2 tank	2.3 volts \pm 10%
3/4 tank	3.5 volts \pm 10%
Full tank	4.7 volts \pm 10%

- If voltage is as shown in Table B, replace the cluster.
 - If voltage is not as shown in Table B, go to step 5.
- 5 Check voltage between RX-2 and LX-3.

- If voltage is as shown in the Table B, check the circuit, connector terminals and wiring from RX-4 to LX-3, and replace components as necessary.
- If voltage is not as shown in Table B, replace the instrument cluster.

- 6 **If the pointer constantly stays on the 1/2 mark, Full mark, or falls below the empty mark,** the most likely cause is a wiring problem.

- a. **If the pointer stays below “E” AND** the pointer moves slightly during the gauge test, there is no signal on the ground input. Check for an open circuit on RX-2. Note that RX-2 is associated with the axle temperature circuit, so that gauge may be affected also.

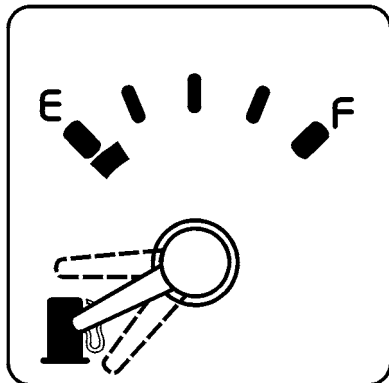

W3000871

- b. **If the pointer stays above “F” AND does not move during the cluster self test,** there is no signal on the +5V input to the cluster. Check LY-15 and RX-12 for an open circuit.

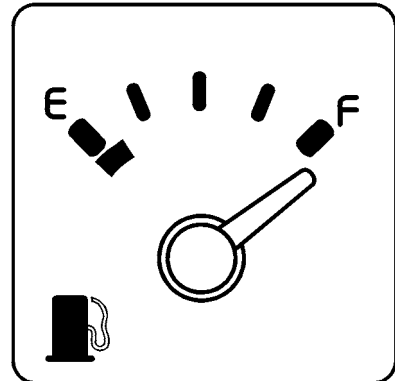

W3000872

- c. **If the pointer stays at the 1/2 mark AND the pointer does not move during the cluster self test,** there is no signal on the fuel level input. Check RX-4 for an open circuit.

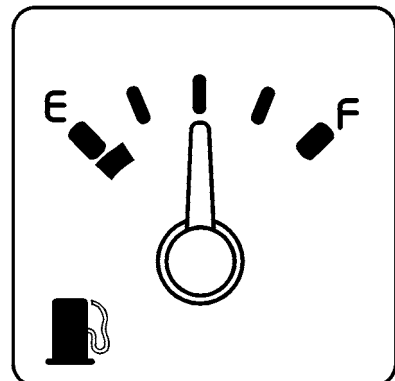

W3000814

Troubleshooting with the MPSI Pro-Link 9000 and VOLVO Cartridge

Special tests

The MPSI Pro-Link 9000² with the Volvo cartridge provides easy diagnosis of faults, with more information than instrument cluster self-diagnostics.

The following tests can be performed with the Pro-Link 9000 and the Volvo cartridge, version 2.0 (see Tools for ordering information).

Gauge tests

These gauges can be individually driven.

Speedometer: The speedometer gauge can be driven in steps of ± 5 mph, from 0–80 mph.

Tachometer: The tachometer gauge can be driven in steps of ± 100 RPM, from 0–2500 RPM.

Engine Oil Pressure: The engine oil pressure gauge can be driven in steps of ± 15 psi, from 0–90 psi.

Engine Oil Temperature: The engine oil temperature gauge can be driven in steps of ± 10 °F, from 50 to 270 °F.

Turbo boost: The turbo boost pressure gauge can be driven in steps of ± 5 psi, from 0–30 psi.

Coolant temp.: The coolant temp gauge can be driven in steps of ± 5 °F, from 150 to 230 °F.

Lamp circuitry tests

The following tests check the function of the telltale lamp circuitry.

High Coolant Temperature

Low Engine Oil Pressure

High Engine Oil Temperature (Caution)

Low Coolant Level (Stop)

²Pro-Link is a registered trademark of MPSI.

View EEPROM

Read functions

Clock Mode 12 or 24 hour mode

Operating Volts 12 or 24 volts

Turbo Gauge indicates whether the turbo gauge is installed

Voltmeter indicates whether the voltmeter display is enabled or disabled

Eng Oil Temp indicates whether the engine oil temperature display is enabled or disabled

Trans Temp indicates whether the transmission oil temp. is enabled or disabled

Fuel Econ indicates whether the fuel economy feature is enabled or disabled

Eng Oil °F Src indicates the signal source for the engine oil temperature from data bus or sensor (VE D12 engine)

Hourmeter This allows the hourmeter total to be checked.

Odometer This allows the odometer total to be checked.

Reprogram EEPROM

Read/write functions

Clock Mode set 12 or 24 hour mode

Operating Volts set 12 or 24 volts

Turbo Gauge enable or disable

Voltmeter enable or disable

Eng Oil Temp Allows checking of whether the engine oil temperature gauge is enabled or disabled. Also allows changing of the status from enabled to disabled, or vice-versa.

Trans Temp Allows checking of whether the transmission oil temperature gauge is enabled or disabled. Also allows changing of the status from enabled to disabled, or vice-versa.

Fuel Econ Allows checking of whether the fuel economy gauge is enabled or disabled. Also allows changing of the status from enabled to disabled, or vice-versa.

Eng Oil °F Src Allows checking of whether the engine oil temperature signal source is from the data bus (Caterpillar, Cummins, Detroit Diesel engines) or from a sensor (Volvo engine). If installing a new cluster into a vehicle, this variable will need to be set for the appropriate engine.

Password-protected read/write functions

The password for instrument cluster software, version 6.5 and above, use four dashes (- - - -) for the password. Earlier versions of software used four zeros (0000). The software version can be looked up in the engine ECU.

Hourmeter This allows the hourmeter total to be checked and changed. It is used when installing a new instrument cluster into a vehicle which already has miles on the engine.

Odometer This allows the odometer total to be checked and changed. It is used when installing a new instrument cluster into a vehicle which already has miles on it.

Service Procedures

Important: Individual gauges on the VN instrument cluster are not serviceable. **Attempts to service or replace individual gauges during the warranty period will void the cluster warranty.** Instead, the whole unit may be exchanged.

ONLY when a certified technician is repopulating a replacement instrument cluster may the cluster be opened during the warranty period.

CAUTION

To prevent electrostatic discharge (ESD), which can damage the sensitive electronic components in the instrument cluster, do the following:

Use a wrist grounding strap and an anti-static mat when working on the instrument cluster.

Work in a clean environment.

Do not place the cluster on a metal table or any metal surface while servicing.

Failure to do the above can result in permanent damage to the printed circuit boards in the instrument cluster.

Updating the odometer reading after replacing the cluster

The odometer and hourmeter values are stored in the cluster. Whenever a new cluster is installed, these values must be updated to reflect the mileage and engine hours of the vehicle in which the cluster is installed. This is done using the MPSI Pro-link 9000 tool with the Volvo cartridge, version 2.0.

To reset either of these readings, follow the Pro-link menus to the *Reprogram EEPROM* menu, then select either the Odometer or Hourmeter Total. Change to the appropriate total.

Note: Reprogramming the Odometer or Hourmeter is a password-protected function.

Cleaning the housing and front panel glass

To clean the housing and front panel glass, use a soft, non-abrasive cloth and a mild soap-and-water solution.

?????-?

Bulb replacement

Removal

1
Make certain the vehicle ignition is **OFF** before beginning this procedure.

2

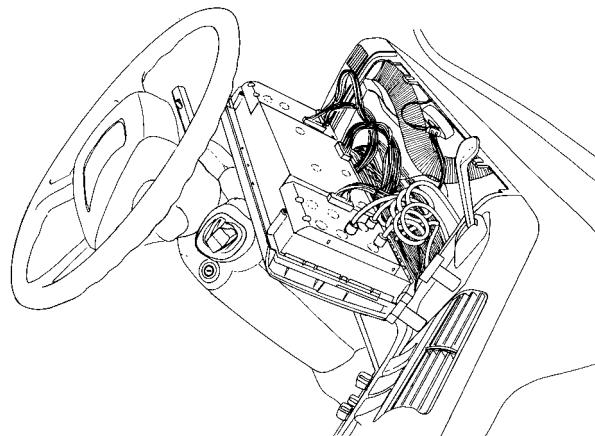

W3000842

CAUTION

When servicing or troubleshooting, do not leave the cluster face-down for more than 15 minutes, or damage to the gauges may occur. Gauge oil can run out the front of the gauge faces and make the gauges inaccurate.

Adjust the steering column back where possible. Remove the two screws at the top of the instrument cluster and lay the cluster face-down on the steering column so that the bulbs are accessible.

3

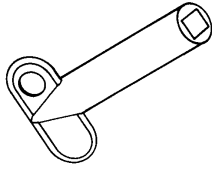

W3000642

 CAUTION
Use only the Volvo bulb removal tool, P/N 1089953, to remove bulbs, or damage to the cluster may occur.

1089953

Insert removal tool, P/N 1089953, onto the bulb assembly. Rotate 1/4 turn and pull the bulb assembly out of the socket.

Installation

1
Insert the new bulb assembly into the removal tool, P/N 1089953. Insert the assembly into cluster socket and rotate 1/4 turn.

1089953

2
Replace the instrument cluster in the dash and tighten the 2 screws at the top of the cluster. Torque to 2 ± 0.3 Nm (17.5 ± 2.5 in-lb).

?????-?

Instrument cluster replacement

Removal

1
Make certain the vehicle ignition is **OFF** before beginning this procedure.

2

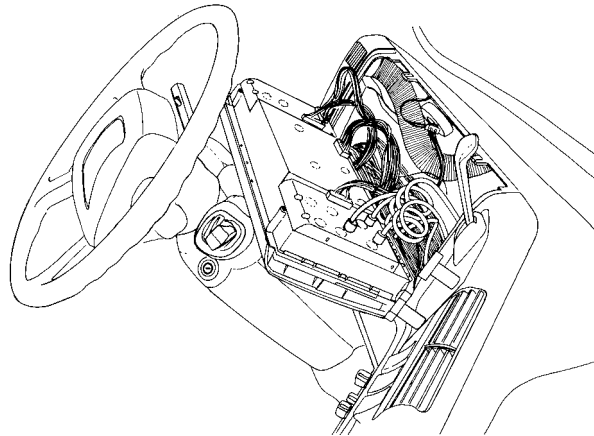

W3000842

 CAUTION
When servicing or troubleshooting, do not leave the cluster face-down for more than 15 minutes, or damage to the gauges may occur. Gauge oil can run out the front of the gauge faces and make the gauges inaccurate.

Adjust the steering column back where possible. Remove the two screws at the top of the instrument cluster and lay the cluster face-down on the steering column.

3
Cut the tie wraps fastening the wiring harness to the back of the cluster for stress relief on the connectors.

4



Never disconnect an air system component unless all system pressure has been depleted. Failure to deplete system pressure before disconnecting hoses or components may result in them separating violently and causing serious bodily injury.

Bleed all pressure from the vehicle air system. Disconnect the electrical and air connectors from the back of the cluster, and remove the cluster from the vehicle.

Installation

1

Connect electrical connectors and air lines at the back of the instrument cluster. For stress relief on the connectors, tie wrap the wiring to the back of the instrument cluster.

2

Install the instrument cluster in dash and tighten the 2 screws at the top of the cluster. Torque to 2 ± 0.3 Nm (17.5 ± 2.5 in-lb).

?????-?

Gauge replacement, right circuit board gauges

Important: Individual gauges on the VN instrument cluster are not serviceable. **Attempts to service or replace individual gauges during the warranty period will void the cluster warranty.** Instead, the whole unit should be exchanged.

ONLY when a certified technician is repopulating a replacement instrument cluster may the cluster be opened during the warranty period.

Removal

1

CAUTION

To prevent electrostatic discharge (ESD), which can damage the sensitive electronic components in the instrument cluster, use a wrist grounding strap and an anti-static mat when working on the instrument cluster. Failure to do so can result in permanent damage to the printed circuit boards in the instrument cluster. Do not place the cluster on a metal table or any metal surface while servicing.

Remove cluster from vehicle (see previous procedure). Place cluster on anti-static mat. The anti-static mat must be grounded to the nearest electrical outlet. When working at the anti-static workbench, always keep a wrist strap connected to the anti-static mat.

2

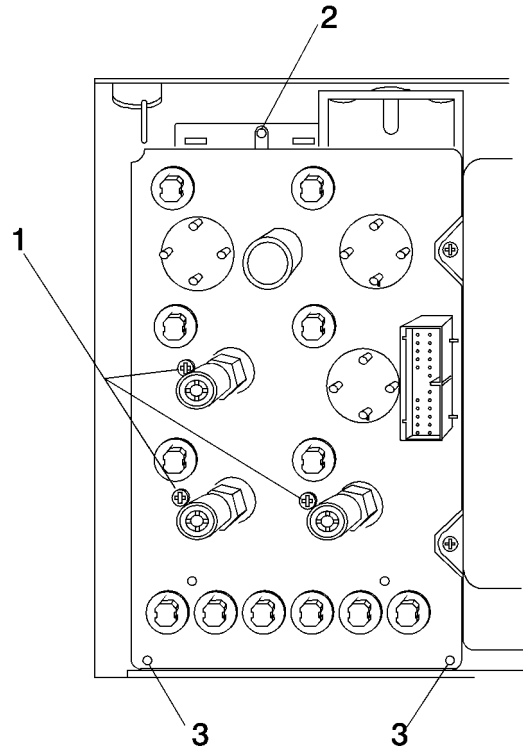

W3000835

- 1) Gauge mounting screws — do not remove at this time
- 2) Top cover screw location
- 3) Bottom cover screw location

Right printed circuit board (PCB) with cover removed

Remove the Phillips screw at the top of the right rear cover, and the two at the bottom, then lift off the cover.

Note: Do not remove any of the three Phillips screws in the board at this time. They secure the air pressure gauges to the board.

3

Lift out the Right Circuit Board assembly, with gauges.

4

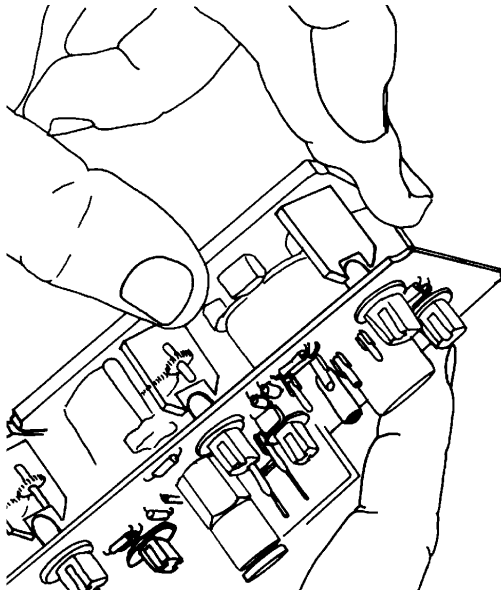

W3000989

⚠ CAUTION

To avoid damaging the gauge, do not push on the needle when removing the gauge. Pushing on the needle can make the gauge inaccurate.

Air pressure gauges only: These are each secured by one Phillips screw. Remove the screw, pull the gauge out of the board and disconnect the 2-pin LED connector.

Other gauges: Gauges are held tightly by their pin sockets. To remove, grasp the side of the gauge face plate with your thumb; place your 2nd and 3rd fingers underneath the face plate (see illustration). Carefully rock the gauge from side to side while applying upward pressure until the gauge pins are free of the board sockets.

Removing a gauge blank

5

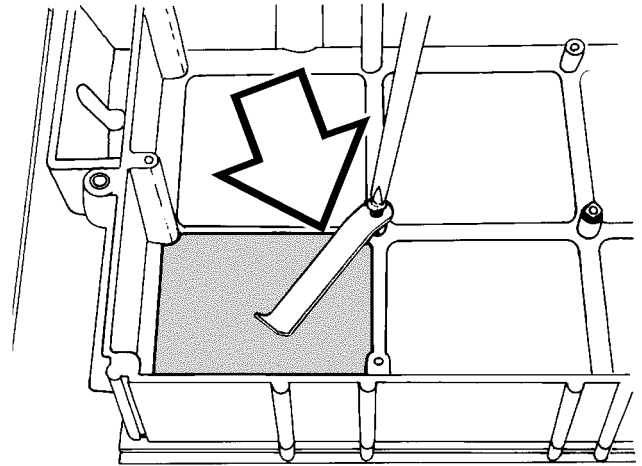

W3000990

Note: Early production models may have gauge blanks as shown in the illustration. If replacing any blank, use the newer gauge blank support assembly shown in the Installation procedure.

When adding a gauge blank, remove the gauge or gauge blank to be replaced.

Installation

1

CAUTION

To avoid damaging the gauge, do not push on the needle when installing the gauge. Pushing on the needle can make the gauge inaccurate.

Install the replacement gauge by grasping the opposite corners of the gauge face plate and pushing the gauge pins into the socket onto the circuit board. Do not push on the needle. (For gauge blanks, see the following steps.) It is correctly installed when its face plate is flush with the other gauges' face plates.

Air pressure gauges only: Connect the 2-pin connector into the board (it is not polarity-sensitive, so it can go in either way) and secure the gauge to the board with a self-tapping Phillips screw.

Adding gauge blanks

2

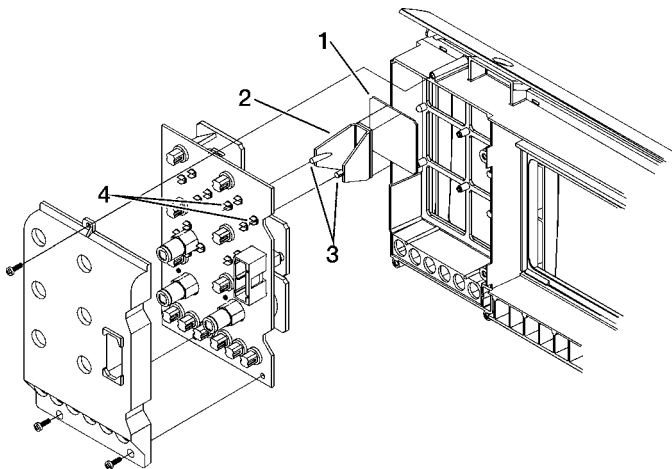

W3000820

- 1) Gauge Blank
- 2) Blank Support Assembly
- 3) Pins
- 4) Terminals

Install the new blank (1) into the cluster housing. Install the blank support (2) in the PC board into the terminals (4) where the gauge was removed.

3

Install the Right Circuit Board assembly into the housing.

4

Place the cover over the board assembly and secure with three machine screws.

5

Install the cluster into the dash (see previous procedure).

6

If installing a gauge blank into the Engine Oil Pressure or Turbo Boost Pressure gauges, use the MPSI Pro-Link 9000 with the VOLVO cartridge to enable the gauge which is being added, or to disable the gauge which is being removed.

?????-?

Center module replacement

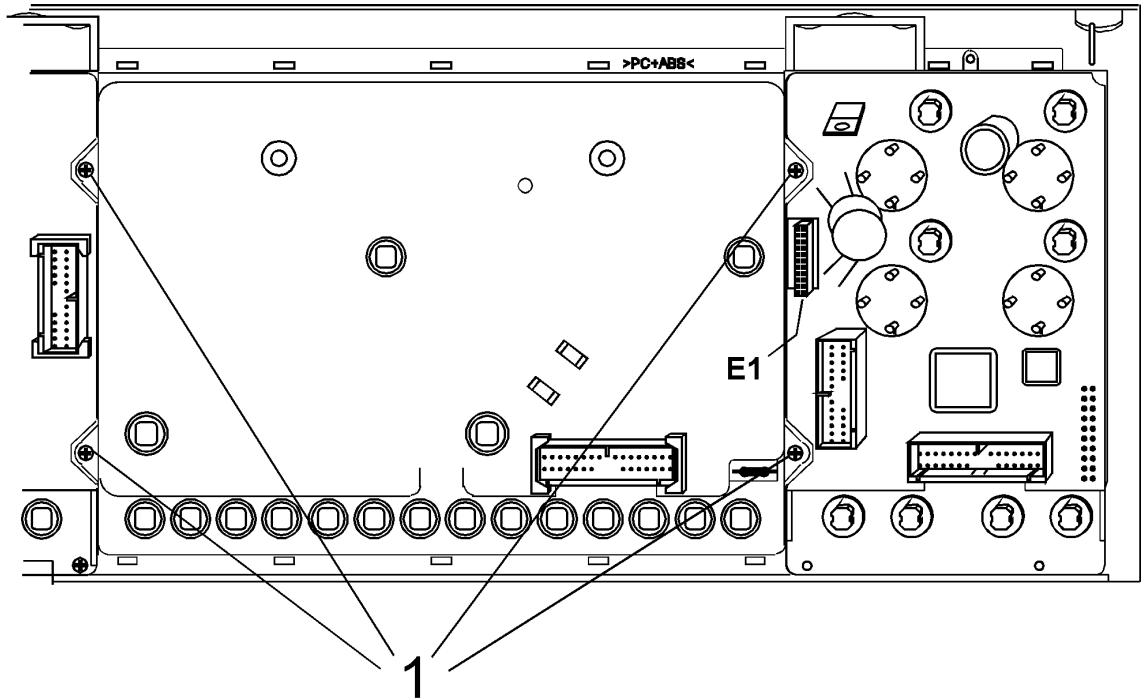

1) Center Module screw locations

W3000739

Removal

1
Important: Individual gauges on the VN instrument cluster are not serviceable. **Attempts to remove and replace individual gauges during the warranty period will void the cluster warranty.** Instead, the whole unit should be exchanged. **ONLY** when a certified technician is repopulating a replacement instrument cluster may the cluster be opened during the warranty period.

2

 CAUTION
<p>To prevent electrostatic discharge (ESD), which can damage the sensitive electronic components in the instrument cluster, use a wrist grounding strap and an anti-static mat when working on the instrument cluster. Failure to do so can result in permanent damage to the cluster.</p>

Remove cluster from vehicle (see previous procedure). Place cluster on anti-static mat. The anti-static mat must be grounded to the nearest electrical outlet. When working at your anti-static workbench, always keep your wrist strap connected to the anti-static mat. Do not place the cluster on a metal table or any metal surface while servicing.

3

Remove the Phillips screws at the top of the left rear cover, and the two at the bottom, then lift the left rear cover from the cluster.

4

Remove the four Phillips cover screws.

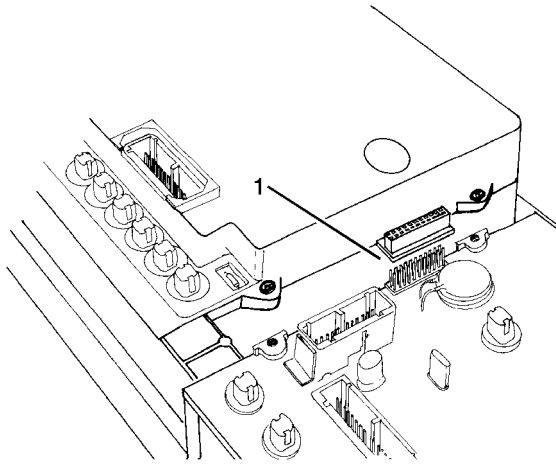
5

W3000845

1) Connector E1

**CAUTION**

Do not bend the printed circuit board. Bending the board can result in damage to the board or components.

Grasp the top and bottom of connector E1 (over the Left Circuit Board) with your thumb and forefinger. Rock the Center Module from top to bottom while pulling up to unseat E1.

6

Remove the Center Module by lifting it off of the cluster.

Installation

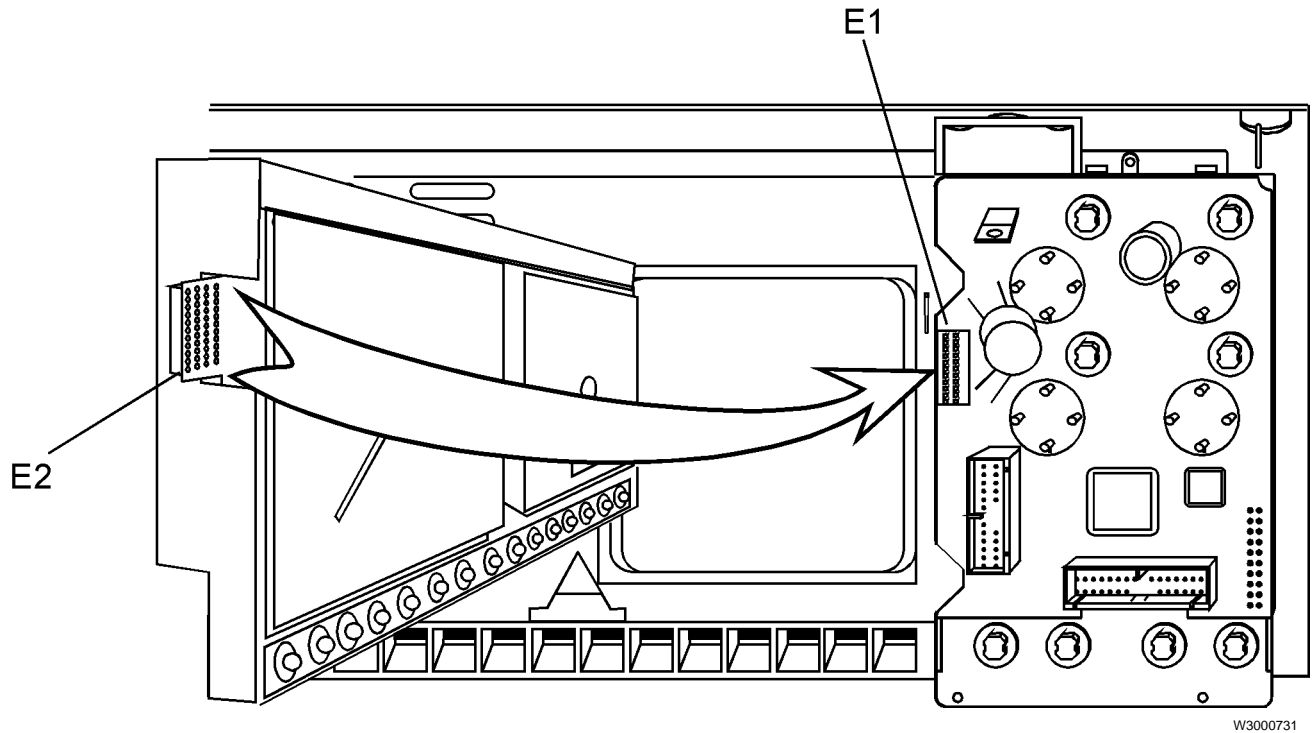

W3000731

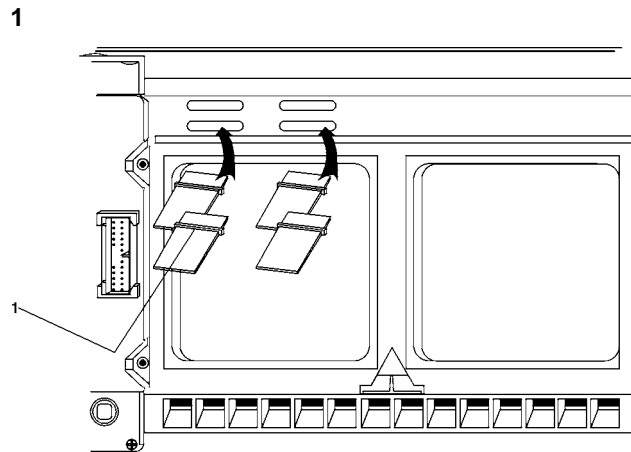

W3000846

1) Button extensions

Before reinstalling the Center Module, make sure that all four plastic button extensions are installed in the top of the housing (the short ends stick out the front of the housing).

2
To reinstall the Center Module, line up connector E1 pins with connector E2 holes on the Center Circuit Board, then carefully seat E2 while lowering the Center Module into the housing.

3
Verify that all E1 pins are in connector E2 holes, then use your thumb to fully seat E2 onto the Left Circuit Board.

4
Secure the Center Module to the housing with four machine screws.

Gauge replacement, left circuit board gauges

Important: Individual gauges on the VN instrument cluster are not serviceable. **Attempts to remove and replace individual gauges during the warranty period will void the cluster warranty.** Instead, the whole unit may be exchanged.

ONLY when a certified technician is repopulating a replacement instrument cluster may the cluster be opened during the warranty period.

Removal

1

CAUTION

To prevent electrostatic discharge (ESD), which can damage the sensitive electronic components in the instrument cluster, use a wrist grounding strap and an anti-static mat when working on the instrument cluster. Failure to do so can result in permanent damage to the printed circuit boards in the instrument cluster.

Remove cluster from vehicle (see previous procedure). Place cluster on anti-static mat. The anti-static mat must be grounded to the nearest electrical outlet. When working at the anti-static workbench, always keep a wrist strap connected to the anti-static mat. Do not place the cluster on a metal table or any metal surface while servicing.

2

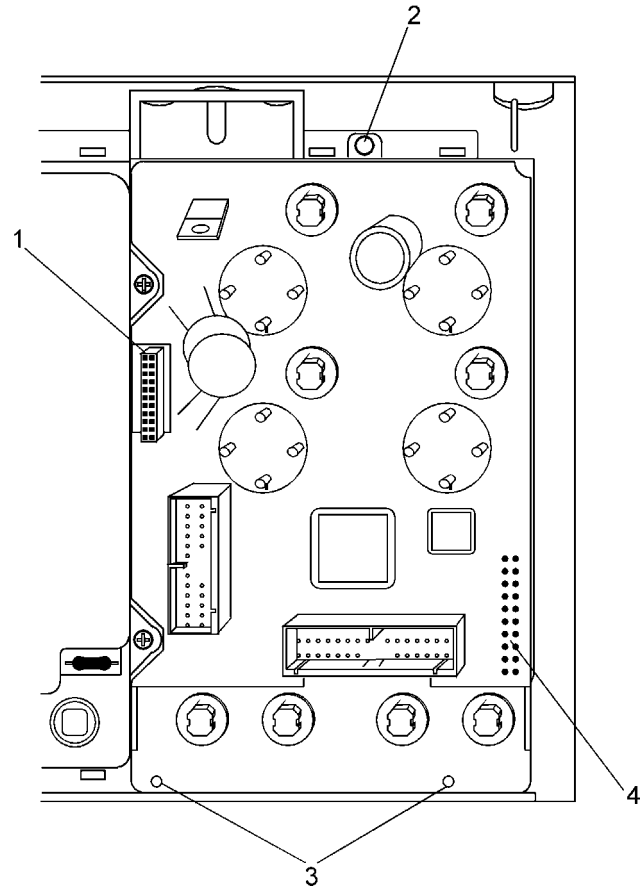

W3000734

- 1) Connector E2 (part of the center circuit board)
- 2) Top cover screw location
- 3) Bottom cover screw location
- 4) Connector E4 to Graphic Display board underneath

Remove the Phillips screw at the top of the left rear cover, and the two at the bottom, then lift off the cover.

Note: Connector E2 is part of the Center Circuit Board.

3

⚠ CAUTION

Do not bend the printed circuit board. Bending the board can result in damage to the board or components.

The Center Circuit Board connector E2 is holding the Left Circuit Board assembly in at this point, so you will have to remove the Center Module before continuing (see previous procedure).

4

Carefully lift out the Left Circuit Board assembly by lifting straight up. It is attached to the Graphic Display board below at connector E4.

5

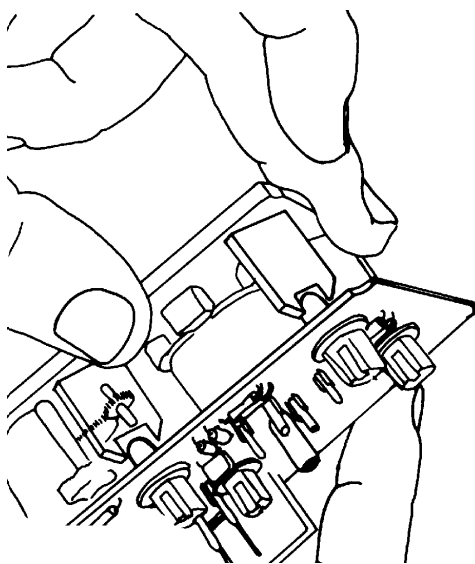

W3000991

⚠ CAUTION

To avoid damaging the gauge, do not push on the needle when removing the gauge. Pushing on the needle can make the gauge inaccurate.

Gauges are held tightly by their pin sockets. To remove, grasp the side of the gauge face plate with your thumb; place your 2nd and 3rd fingers underneath the face plate (see illustration). Carefully rock the gauge from side to side while applying upward pressure until the gauge pins are free of the board sockets.

Removing a gauge blank

6

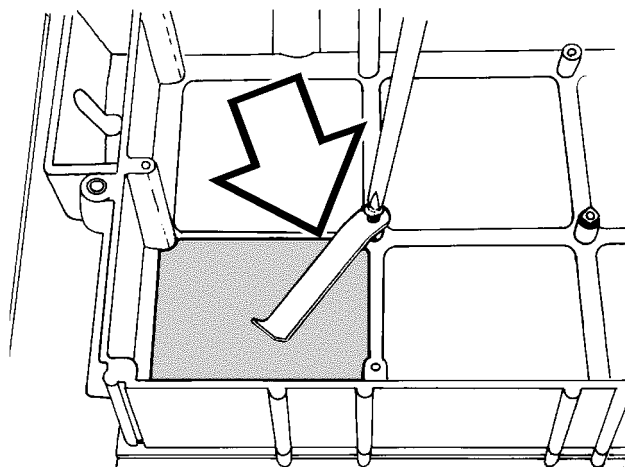

W3000990

Note: Early production models may have gauge blanks like the above. If replacing a blank, use the newer gauge blank support assembly shown in the Installation procedure.

When adding a gauge blank, remove the gauge or gauge blank to be replaced.

Installation

1

CAUTION

To avoid damaging the gauge, do not push on the needle when installing the gauge. Pushing on the needle can make the gauge inaccurate.

Install the replacement gauge by grasping the opposite corners of the gauge face plate and pushing the gauge pins into the socket onto the circuit board. Do not push on the needle. (For gauge blanks, see the following steps.) It is correctly installed when its face plate is flush with the other gauges' face plates.

Adding gauge blanks

2

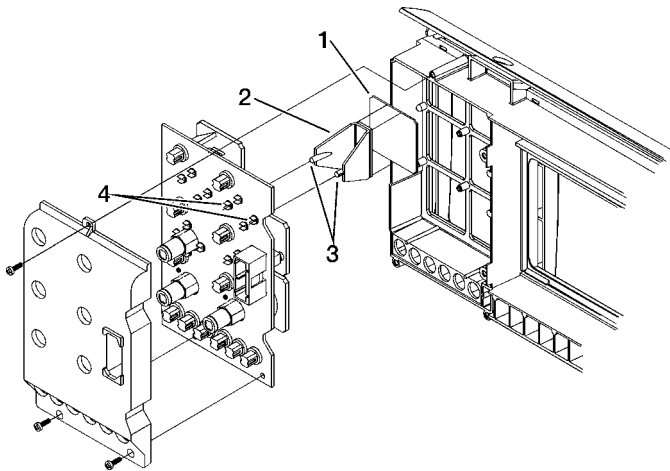

W3000820

- 1) Gauge Blank
- 2) Blank Support Assembly
- 3) Pins
- 4) Terminals

Install the new blank (1) into the cluster housing. Install the blank support (2) in the PC board into the terminals (4) where the gauge was removed.

3

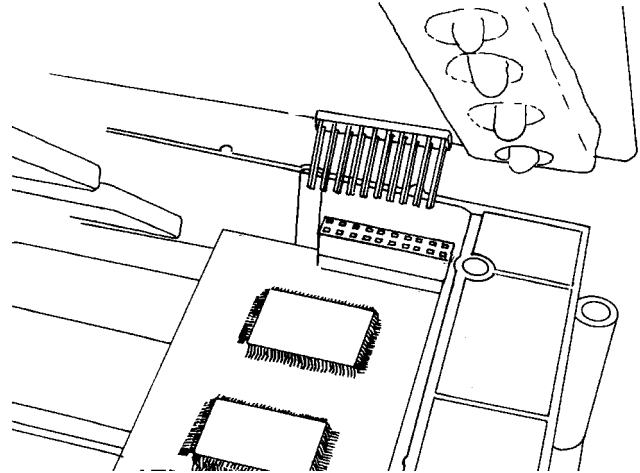

W3000750

Important! Before installing the Left Circuit Board assembly, check connector E4 pins and make sure they are all perfectly straight and parallel to each other.

4

Place the Left Circuit Board assembly into the housing while lining up E4 pins into the Graphic Display connector.

5

Install the Center Module, paying particular attention to connector E1 on the Left Circuit Board assembly.

6

Install the left rear cover and secure it with three machine screws.

7

Install the cluster into the dash (see previous procedure).

8

If installing a gauge blank into the Engine Oil Pressure or Turbo Boost Pressure gauges, use the MPSI Pro-Link 9000 with the VOLVO cartridge to enable the gauge which is being added, or to disable the gauge which is being removed.

9

Important: If the Left Circuit Board has been replaced, update the odometer and hourmeter values to reflect the vehicle's actual mileage and engine hours. This is done with the MPSI Pro-Link 9000.

VOLVO
Volvo GM Heavy Truck

Volvo GM Heavy Truck Corporation 7825 National Service Road P.O. Box 26115 Greensboro, NC 27402-6115
Volvo GM Canada Heavy Truck Corp. 6490 Vipond Drive Mississauga, Ontario L5T 1W8