

# KODAK X - OMAT Multiloader 300 Plus



### **PLEASE NOTE**

The information contained herein is based on the experience and knowledge relating to the subject matter gained by Kodak prior to publication. No patent license is granted by this information. Kodak reserves the right to change this information without notice, and makes no warranty, expressed or implied, with respect to this information. Kodak shall not be liable for any loss or damage, including consequential or special damages, resulting from the use of this information.

# CONTENTS

---

<b>INTRODUCTION</b> .....	<b>1-1</b>
<b>SPECIFICATIONS</b> .....	<b>1-2</b>
<b>RADIO INTERFERENCE SUPPRESSION</b> .....	<b>1-4</b>
<b>DECLARATION OF CONFORMITY</b> .....	<b>1-4</b>
<b>SAFETY STANDARDS</b> .....	<b>1-4</b>
<b>WARNINGS</b> .....	<b>1-5</b>
<b>QUICK REFERENCE OPERATING INSTRUCTIONS</b> .....	<b>1-6</b>
PERFORMING THE DAILY START-UP PROCEDURE.....	1-6
INSERTING A CASSETTE.....	1-10
SWITCHING OFF THE <b>KODAK X-OMAT MULTILOADER 300 PLUS</b> .....	1-13
<b>GENERAL DESCRIPTION</b> .....	<b>1-14</b>
IN OPERATION.....	1-14
CASSETTE SIZES AND TYPES.....	1-15
FILM SUPPLY MAGAZINE.....	1-15
SPECIAL FUNCTIONS.....	1-15
OPERATING CONTROLS, STATUS LIGHTS, AND DISPLAY.....	1-16
APPLICATION.....	1-17
MAGAZINE STATUS.....	1-18
<b>MAGAZINE ACCESS</b> .....	<b>1-19</b>
LOADING THE MAGAZINES.....	1-19

<b>SPECIAL FUNCTIONS</b> .....	<b>1-23</b>
LOAD ONLY .....	1-23
UNLOAD ONLY .....	1-24
SERIAL UNLOADING.....	1-25
FUNCTION .....	1-28
FILM TYPE 2 .....	1-29
FILM USAGE.....	1-30
LANGUAGES.....	1-32
<b>ERROR MESSAGES</b> .....	<b>1-33</b>
HOW TO REMOVE A CASSETTE .....	1-35
<b>INTEGRATED KODAK X-OMAT 3000 RA PROCESSOR</b> .....	<b>1-37</b>
THE DISPLAY .....	1-37
CHANGING THE DRYER TEMPERATURE.....	1-38
CHANGING THE PROCESSING CYCLE.....	1-38
CYCLE INFORMATION FOR THE PROCESSOR .....	1-39
ENTERING AND EXITING SLEEP MODE.....	1-40
DISPLAYING THE FIXER TEMPERATURE .....	1-41
DISPLAYING THE TIME AND DATE .....	1-41
<b>CLEAN-UP AND PREVENTATIVE MAINTENANCE</b> .....	<b>1-42</b>
WEEKLY CLEAN-UP AND MAINTENANCE OF THE INTEGRATED KODAK X-OMAT 3000 RA PROCESSOR .....	1-42
MAINTENANCE OF THE HUMIDIFIER .....	1-46
<b>WARRANTY</b> .....	<b>1-47</b>

<b>KEY OPERATOR INSTRUCTIONS</b> .....	<b>2-1</b>
RESIZING MAGAZINES.....	2-1
TYPE 2 CODING OF CASSETTES .....	2-6
C1 CASSETTES.....	2-6
C2 CASSETTES.....	2-7
C3 CASSETTES.....	2-7
<b>KODAK MIN-R 2 CASSETTE</b> .....	2-8
<b>KODAK X-OMATIC VIDEO FILM HOLDER</b> .....	2-8
FAILURES AND ERROR HANDLING .....	2-9
FUNCTION BUTTONS.....	2-11
<b>KODAK X-OMAT MULTILOADER 300 PLUS KEY OPERATOR INSTRUCTIONS</b>	2-12
FAILURES NOT DETECTED BY THE	
<b>KODAK X-OMAT MULTILOADER 300 PLUS</b> .....	2-13
USING THE ACCESS CODE .....	2-15
MIXING THE CHEMISTRY.....	2-17
FILLING THE TANKS OF THE INTEGRATED	
<b>KODAK X-OMAT 3000 RAPROCESSOR</b> .....	2-19
SELECTING PROCESSOR OPTIONS .....	2-22
A. REPLENISHMENT MODE.....	2-22
B. SELECTING THE START-UP OPTION .....	2-24
C. SELECTING THE DISPLAY UNITS FOR TEMPERATURE AND TRANSPORT SPEED .....	2-25
D. SELECTING A STAND-BY MODE .....	2-26
E. SELECTING SLEEP MODE OPTIONS .....	2-28
SELECTING PROCESSOR CYCLE K/RA.....	2-31
SELECTING THE K/RA CYCLE SETPOINT DEFAULTS .....	2-32
SETTING UP THE PROCESSOR.....	2-33
A. DEVELOPER AND FIXER SETPOINT TEMPERATURES.....	2-33
B. REPLENISHMENT VOLUME.....	2-35
C. PROCESSOR SPEED .....	2-38
D. TIME AND DATE.....	2-40

E. AUTOMATIC ON AND OFF TIMERS.....	2-43
F. CALIBRATING THE REPLENISHMENT SYSTEM.....	2-49
PROBLEM SOLVING .....	2-52
PROCESSOR SET-UP AND OPTIONS .....	2-54

## INTRODUCTION

---

Welcome to the world of Multiloaders!

Your KODAK X-OMAT Multiloader 300 Plus is a compact processor-controlled roomlight film handling and film processing system. The KODAK X-OMAT Multiloader 300 Plus can hold up to three film supply magazines and is compatible with all sizes of KODAK X-OMATIC Cassettes, KODAK MIN-R 2 Cassettes and the KODAK X-OMATIC Video Film Holder.

Exposed film is automatically removed from the cassette inserted into your KODAK X-OMAT Multiloader 300 Plus, the cassette reloaded with fresh film and returned to the operator in less than 20 seconds.

Exposed film is fed into the integrated KODAK X-OMAT 3000 RA Processor. The integrated KODAK X-OMAT 3000 RA Processor is capable of operating at 4 different user selectable speeds for either K/RA, Rapid, Standard, or Extended cycle processing of film.

In the K/RA cycle your KODAK X-OMAT Multiloader 300 Plus is compatible with the KODAK T-MAT RA films and KODAK RA/30 chemistry.

The operator interface is at the front of your KODAK X-OMAT Multiloader 300 Plus for cassette insertion and exit, film supply magazine access and film exit. The operator control panel and access to the integrated KODAK X-OMAT 3000 RA Processor are also at the front of your KODAK X-OMAT Multiloader 300 Plus.

### **IMPORTANT:**

**Please be aware of the fact that this unit may only be used for loading and unloading of film cassettes (sizes and types as specified on page 1-2 of this Operator Guide) and feeding exposed films into the integrated KODAK X-OMAT 3000 RA Processor.**  
**The unit must not be used for any other operations.**

## SPECIFICATIONS

---

### Cassette Sizes:

KODAK X-OMATIC 18 x 24 cm, 24 x 24 cm, 24 x 30 cm,  
30 x 35 cm, 30 x 40 cm, 35 x 35 cm,  
35 x 43 cm, 18 x 43 cm, 20 x 40 cm,  
8 x 10", 10 x 12", 11 x 14"

C1, C2, C3

KODAK MIN-R 2 18 x 24 cm, 24 x 30 cm

KODAK X-OMATIC  
Video Film Holder 8 x 10"

**Magazine Capacity:** 110 films

**Magazines in position:** 3

**Cassette Return Time:** 15-20 seconds

### Access Times /

### Recommended Processing

<b>Temperature:</b>	*K/RA	80 seconds	35.5°C (96°F)
	Rapid	103 seconds	37.2°C (99°F)
	Standard	137 seconds	34.4°C (94°F)
	Extended	245 seconds	34.4°C (94°F)

**Capacity:** 80 to 200 cassettes/hour dependent on  
process cycle (35 x 43 cm)

<b>Dimensions:</b>	Width	82.5 cm	(32.5")
	Height	128.0 cm	(50.4")
	Depth	85.3 cm	(33.6")

**Weight:** 395 kg with solutions and full magazines (871 lbs)

### Recommended Operating

**Conditions:** Temperature 18-24° C (65-75°F)  
Humidity 30-60% RH  
Atmospheric pressure **tbd**.

\* Special RA films and chemicals must be used



**Power Supply:**

1/N/PE~  
 2/PE~  
 3/PE~  
 3/N/PE~

**Voltage set on installation:**

50/60 Hz 6 kW  
 50/60 Hz 6 kW  
 50/60 Hz 5,5 kW  
 50/60 Hz 6 kW

A sticker showing the voltage set on installation will be fixed on the above space by your KODAK SERVICE PROVIDER.

**Max. Power Consumption:**

6 kW

**Heat Dissipation:**

Stand-by 1800KJ/HR (1706 BTU)  
 Max. 9700KJ/HR (9194 BTU)

**Noise level:**

69 dBA sound power level

**Water Supply:**

3,8 l/min 173-692 kPa (25-100 psi)  
 4.0-29° C (40-85° F)

**Air Exhaust Building System :**2,124 l/min (75ft<sup>3</sup>/min) max. full load**Recommended Chemicals:**

KODAK RP X-OMAT Developer Replenisher  
 KODAK RP X-OMAT Fixer Replenisher  
 KODAK X-OMAT RA Developer  
 KODAK X-OMAT RA Fixer

The unit is provided with separate drain valves for fixer and developer.

**Fuses (Europe) for KODAK X-OMAT Multiloader 300 Plus:**

F1: T 1.60 A      F2: T 1.6 A  
 F3: T 8.00        F4: T 6.30 A  
 F5: T 3.15 A      F6: T 4.00 A  
 F7: T 1.60 A      F8: T 3.15 A  
 F9: T 3.15 A      F10: T 3.15 A  
 F11: T 3.15 A

## RADIO INTERFERENCE SUPPRESSION

---

### **U. S. A.: Warning**

This equipment generates, uses and can radiate radio-frequency energy, and if not installed and used in accordance with the Instruction Manual, may cause interference to radio communications. It has been tested and found to comply with the limits for a Class A computing device pursuant to Subpart J of Part 15 of FCC Rules, which are designed to provide reasonable protection against such interference when operated in a commercial environment. Operation of this equipment in a residential area is likely to cause interference, in which case the user at the user's own expense will be required to take whatever steps may be required to correct the interference.

### **Canada:**

- This digital apparatus does not exceed the Class A limits for radio noise emissions from digital apparatus set out in the Radio Interference regulations of the Canadian Department of Communications.
- Le présent appareil numérique n'émet pas de bruits radioélectriques dépassent les limites applicables aux appareils numériques de la class A prescrites dans le Règlement sur le brouillage radioélectrique édicté par le ministre des Communications du Canada.

## DECLARATION OF CONFORMITY

---

We declare our sole responsibility that the KODAK X-OMAT Multiloader 300 Plus to which this declaration relates is in conformity with the following standards and, therefore, bears a CE mark:

**EN 60950, EN 60601-1-2/1994, EN 60601-1-4/1996**

following the provisions of the applicable directives

**MDD 93/42/EEC and amendments.**

## SAFETY STANDARDS

---

The KODAK X-OMAT Multiloader 300 Plus is in conformity with international safety requirements and bears the following safety marks:

- UL (Underwriter Laboratories, UL 122)
- CSA (Canadian Standards Association, CSA 22.2 No. 950)
- GM (TÜV Rhineland, EN 60950)

## WARNINGS

### WARNINGS:

**Dangerous voltages are present in this machine.**

**The operator is only allowed to open the top cover and the magazine door, and to roll out the integrated KODAK X-OMAT 3000 RA Processor as described on page 1-42 of this manual.**

**This product does not contain any parts that would have to be repaired by the operator.**

**Do not perform repairs yourself, call for a qualified service person.**

**Never cover the venting slots of the KODAK X-OMAT Multiloader 300 Plus.**

According to European EN safety regulations for medical devices, direct contact between the patients and the KODAK X-OMAT Multiloader 300 Plus is not allowed. The KODAK X-OMAT Multiloader 300 Plus must be properly connected to the equipotential equalization device (E<sup>2</sup>D), if the unit is operated within a distance of 1.5 m from the patient. The E<sup>2</sup>D and the connecting cable must be provided by the customer. The purpose of the equipotential equalization device is to ensure that all medical devices are connected to the same ground potential.

If, on installation, your KODAK SERVICE PROVIDER connected the KODAK X-OMAT Multiloader 300 Plus to the equipotential busbar using the equipotential bonding plug, this connection may not be interrupted, i. e. you are not allowed to pull off the cable coming from the equipotential busbar (see illustration below).

**The unit requires a constant active exhaust 24 hours a day 7 days a week.**

**Failure to follow this requirement will cause destruction of the machine which will not be covered by any warranty.**

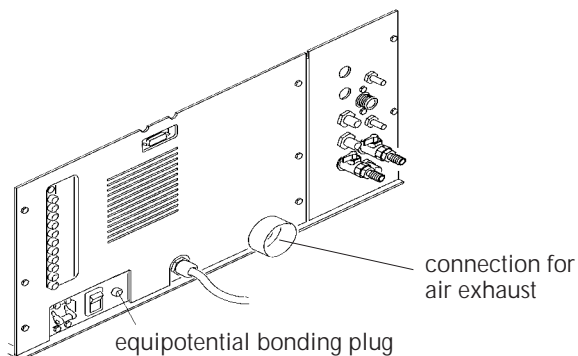

## QUICK REFERENCE OPERATING INSTRUCTIONS

### PERFORMING THE DAILY START-UP PROCEDURE

#### WARNINGS:

**Dangerous voltage.**

**Always disconnect the main power (power plug and wall mounted circuit breaker) before performing any of the following procedures.**

**Only personnel trained by KODAK for this purpose may carry out the following steps.**

**Wear rubber gloves, safety glasses, and protective clothing when doing any maintenance procedures. Report any change in the operating condition of the integrated KODAK X-OMAT 3000 RA Processor to your service personnel .**

1. Turn off the main power source.
2. Release the latches.

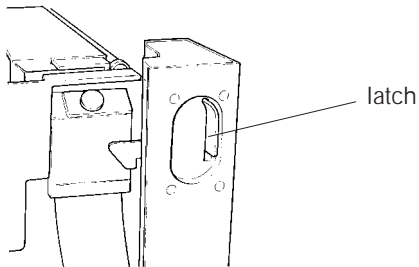

3. To avoid splashing chemicals GENTLY slide out the integrated KODAK X-OMAT 3000 RA Processor, and remove the wet section cover.

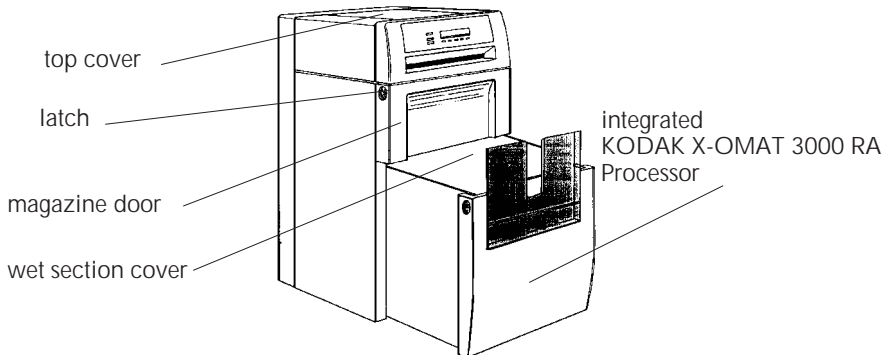

4. Check that the racks and crossovers are in their correct positions

5. Check that the water reservoir is in position.
6. Check that the 2 crossover troughs (not shown) are on the bottom of the developer/fixer and fixer/wash crossovers.
7. Check that the water disconnect is connected.
8. Check that developer and fixer solutions are near the overflow levels of each tank.
9. Install the evaporation covers and the wet section cover if they are not already installed.

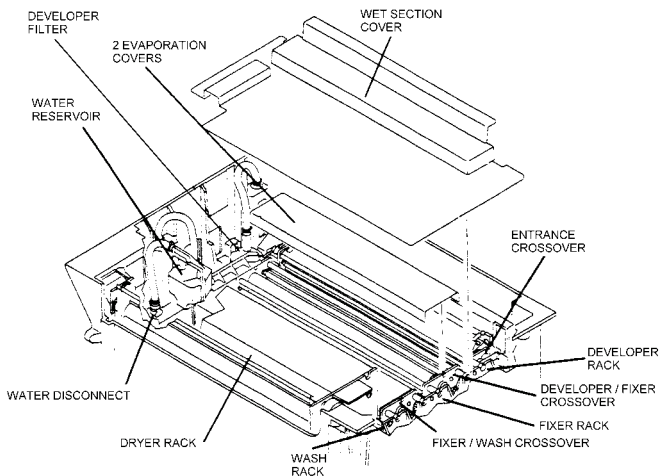

10. Re-insert the wet section cover.
11. Gently slide in the integrated KODAK X-OMAT 3000 RA Processor.

**CAUTION:**

**To reduce/minimize the possibility of personal injury when rolling the integrated KODAK X-OMAT 3000 RA Processor into the KODAK X-OMAT Multiloader 300 Plus, follow the procedure described on page 1-45.**

12. Ensure that the magazine door and the top cover of the KODAK Multiloader 300 Plus are closed.

13. Turn on the water.

**NOTE:**

The temperature of the incoming water should be between 4 and 29°C (40 and 85°F).

14. Switch On:

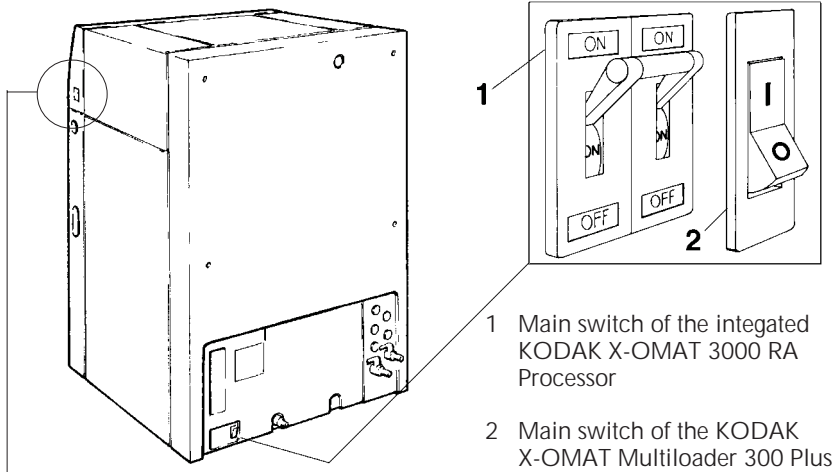

The two switches shown in the above illustration must always be in position "ON/I" to ensure that the fan is running.

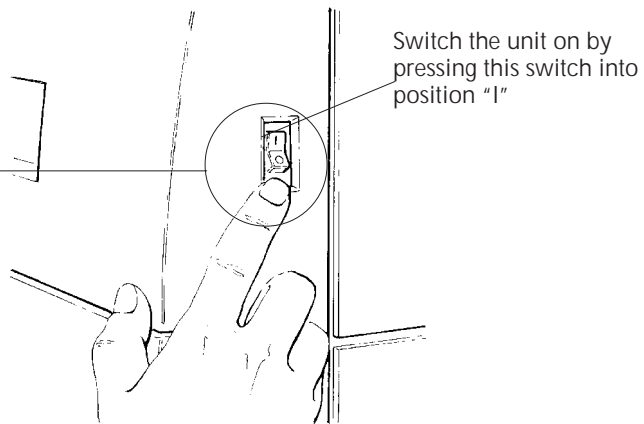

The integrated KODAK X-OMAT 3000 RA Processor will require a warm-up period of approximately 20 minutes. During this period the display will show:

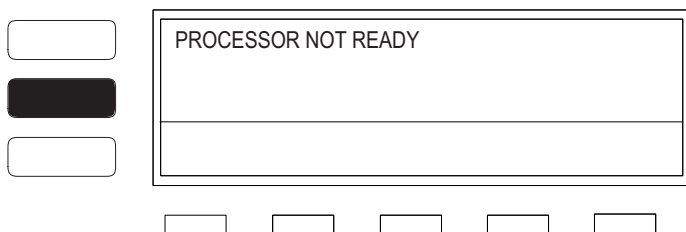

And the ORANGE status light will be on.

When the integrated KODAK X-OMAT 3000 RA Processor has reached the required temperature the display will show:

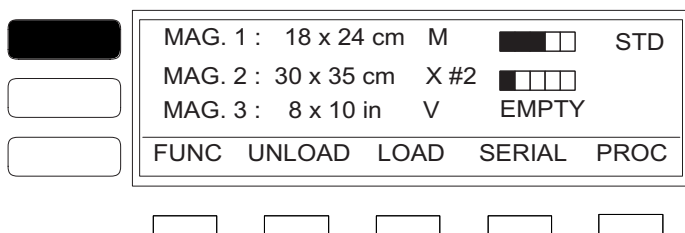

And the GREEN status light will be illuminated.

The KODAK X-OMAT Multiloader 300 Plus is ready for use.

**NOTE:**

You can also program the integrated KODAK X-OMAT 3000 RA Processor to turn on automatically by setting the automatic on/off timers (see chapter "AUTOMATIC ON AND OFF TIMERS" in the Key Operator Instructions on page 2-43 for the procedure.)

## INSERTING A CASSETTE

The KODAK X-OMAT Multiloader 300 Plus will only accept KODAK X-OMATIC cassettes, KODAK X-OMATIC Video Film Holder and KODAK MIN-R 2 Cassettes.

Check that the GREEN status light is on and the display indicates that a corresponding size of magazine is available.

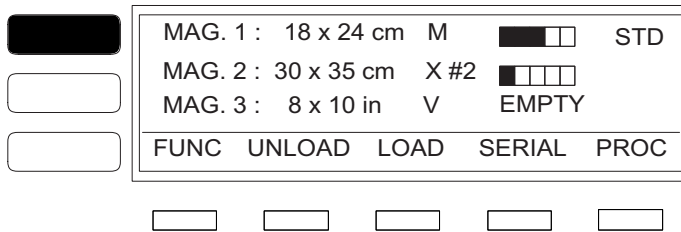

### Insert the Cassette:

Latch side upper most and metal edge towards the KODAK X-OMAT Multiloader 300 Plus.

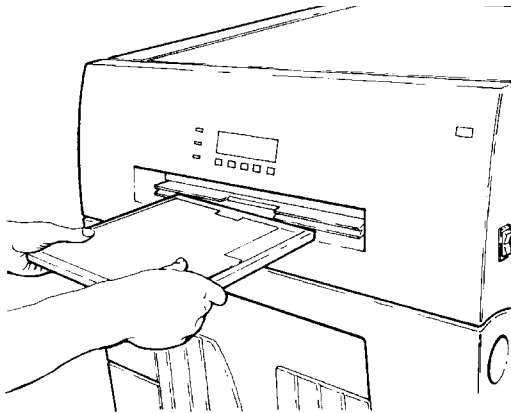

### WARNING:

Do not place hands in cassette entrance. Release cassette as soon as it is pulled into the KODAK X-OMAT Multiloader 300 Plus.



The cassette will be pulled into the KODAK X-OMAT Multiloader 300 Plus, and the ORANGE status light will come on. The display will show:

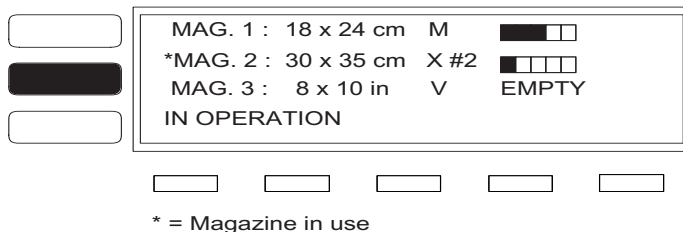

This indicates that a cassette is inside the KODAK X-OMAT Multiloader 300 Plus, and an unload/load operation cycle is in progress.

After loading with a fresh film the cassette will be returned. When the cassette is removed the GREEN status light will illuminate. The ORANGE light will remain on until the film exits the integrated KODAK X-OMAT 3000 RA Processor.

The display will return to the main menu. The KODAK X-OMAT Multiloader 300 Plus is ready for the next operation.

If the GREEN and ORANGE status lights are on, a film is still inside the integrated KODAK X-OMAT 3000 RA Processor, but the system is ready to accept the next cassette.

Should the RED status light flash and the audible alarm sound, please observe the messages on the display.

The warning message must be cancelled by pressing the soft switch marked < CLEAR >, after the cassette has been removed.

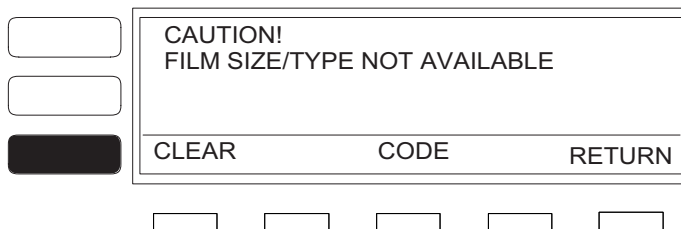

When pressing the <CODE > key, an error code will be displayed. Please write down that code.

If the RED status light is constantly on and the audible alarm sounds a malfunction has occurred. In this case follow the instructions given on the display and refer to the chapter ERROR MESSAGES on page 1-33.

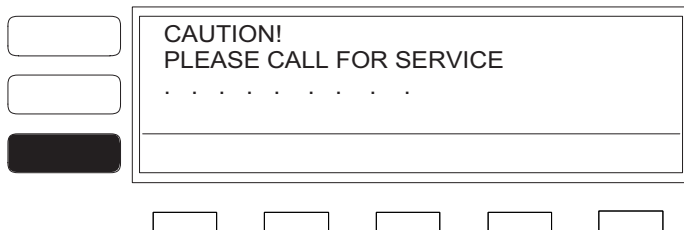

For other functions please see chapter "Special Functions" on page 1-23.

## SWITCHING OFF THE KODAK X-OMAT MULTILOADER 300 PLUS

Switch off the KODAK X-OMAT Multiloader 300 Plus as indicated below.

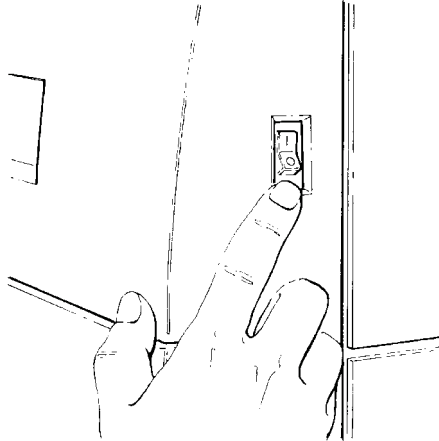

Turn off the water supply.

If you switch off the KODAK X-OMAT Multiloader 300 Plus overnight or for a longer period of time, take the following action to avoid condensation:

1. Pull out the integrated KODAK X-OMAT 3000 RA Processor as described on page 1-42.
2. Remove the wet section cover (see illustration on page 1-7).

### NOTE:

For information on how to program the integrated KODAK X-OMAT 3000 RA Processor to turn off automatically by setting the automatic off timer refer to chapter "AUTOMATIC ON AND OFF TIMERS" in the Key Operator Instructions on page 2-43 for the procedure.

## GENERAL DESCRIPTION

---

The KODAK X-OMAT Multiloader 300 Plus is an integrated load/unload/processing unit.

Both the load/unload module and the module of the integrated KODAK X-OMAT 3000 RA Processor are microprocessor-controlled. Special functions, statistics, and controls are accessed by the soft switches and display unit on the front panel.

There are neither mechanical nor operator interventions to the processor module other than routine cleaning.

Processor controls and messages via soft switches and display unit are detailed within the chapter "INTEGRATED KODAK X-OMAT 3000 RA PROCESSOR".

### IN OPERATION

---

After the cassette has entered the KODAK X-OMAT Multiloader 300 Plus the cassette size is determined and the correct magazine selected.

The cassette is opened and the exposed film is removed and transported via the conveyor to the chute and processor interface. The interface feeds the film to the integrated KODAK X-OMAT 3000 RA Processor. The KODAK X-OMAT Multiloader 300 Plus initiates the integrated KODAK X-OMAT 3000 RA Processor and sends the film dimensions to the processor replenisher system for accurate area replenishment. At the same time a fresh film is selected from the magazine and loaded into the cassette.

The cassette is closed, then returned to the operator within 20 seconds from cassette insertion.

## CASSETTE SIZES AND TYPES

Types: KODAK X-OMATIC Cassette C-1, C-2, C-3  
 KODAK MIN-R 2 Cassette  
 KODAK X-OMATIC Video Film Holder

Sizes: KODAK X-OMATIC Cassette

18 x 24	24 x 30	8 x 10"
18 x 43	30 x 35	10 x 12"
24 x 24	30 x 40	11 x 14"
20 x 40	35 x 35	
	35 x 43	

KODAK MIN-R 2 Cassette  
 18 x 24      24 x 30

KODAK X-OMATIC Video Film Holder  
 8 x 10"

## FILM SUPPLY MAGAZINE

Magazines are available for all cassette sizes, of which three may be installed in the KODAK X-OMAT Multiloader 300 Plus at any one time.

The magazines may contain up to 110 films each.

## SPECIAL FUNCTIONS

**LOAD, UNLOAD ONLY** and **SERIAL UNLOAD** may be selected by the soft switches on the front panel.

**UNLOAD ONLY** and end of **SERIAL UNLOAD** will return the cassette with the latch open and empty.

**Type 2** (alternative grade of film) may be selected manually via the soft switch or automatically by coded cassettes.

## OPERATING CONTROLS, STATUS LIGHTS, AND DISPLAY

---

GREEN On	KODAK X-OMAT Multiloader 300 Plus is ready, cassette may be inserted.
ORANGE On	In operation, cassette is being unloaded/loaded.
GREEN On and ORANGE On	KODAK X-OMAT Multiloader 300 Plus is ready, film is in the integrated KODAK X-OMAT 3000 RA Processor.
RED Flashing	<b>Warning indication</b> , observe messages on display.
RED On	Malfunction indication, observe messages on the display and follow instructions given.

An audible alarm will draw attention to the RED status light.

APPLICATION

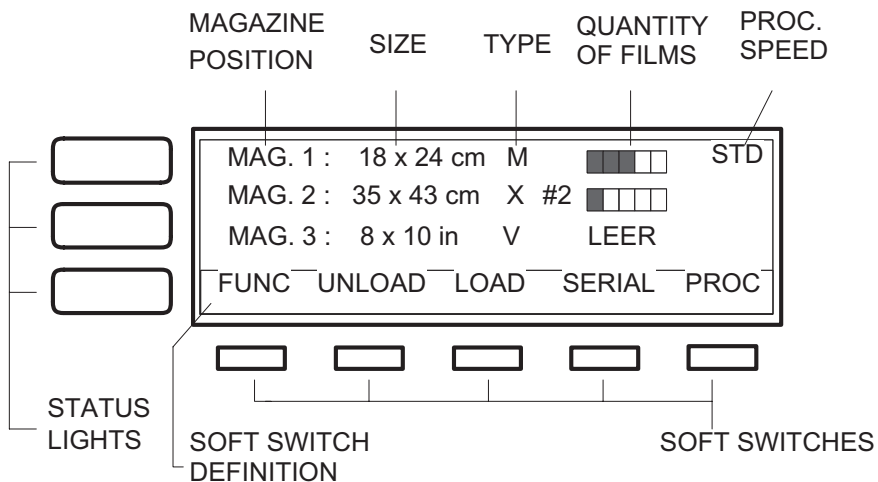

- X Radiography (X-OMATIC Cassette)
- M Mammography (MIN-R 2 Cassette)
- V Video (X-OMATIC Video Film Holder)
- #2 Alternative or Special film
- ? The ? sign indicates that a fresh magazine has been installed and until it has been used the KODAK X-OMAT Multiloader 300 Plus does not know the volume of film within the magazine.

**MAGAZINE STATUS**

(Shown on the display)



more than 70 films



50 - 70 films



30 - 50 films



10 - 30 films



10 or less films

(flashing)

**EMPTY**

magazine empty

**?**

unknown status



## MAGAZINE ACCESS

---

The magazine door can only be opened in the READY mode. Opening the door will turn on the ORANGE light. When the door is closed again, the display will go back to the main display, and the GREEN status light will go on.

- (1) When the magazine door is opened, the display will change as shown and the status light will go to ORANGE.
- (2) When a magazine is removed, the display will show the magazine level without size, application, type and film quantity.
- (3) When a new magazine is inserted, or the same is inserted again, the display will show a '?' for the film quantity, because the magazine film quantity is not known until the first film is removed from the magazine.

## LOADING THE MAGAZINES

---

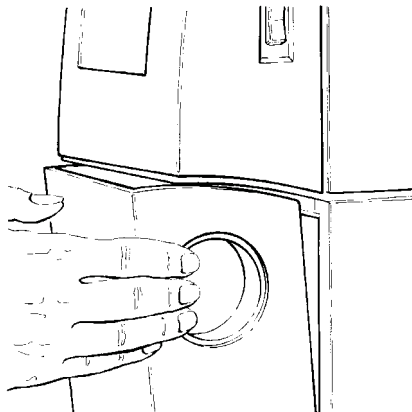

You can now pull open the magazine door.

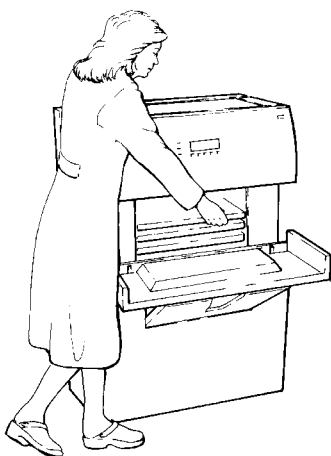

Lift the magazine slightly and pull it straight out.

Close the magazine door.

Place the magazine on a flat surface **in the darkroom**. Push both latches in and lift the lid to open magazine.

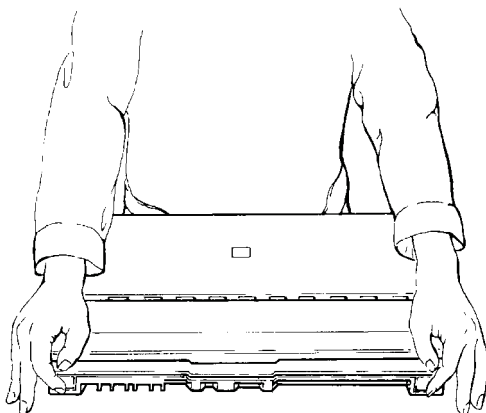

Open film pack. Remove films and fan them carefully. It might be helpful to divide the film pack in several stacks.

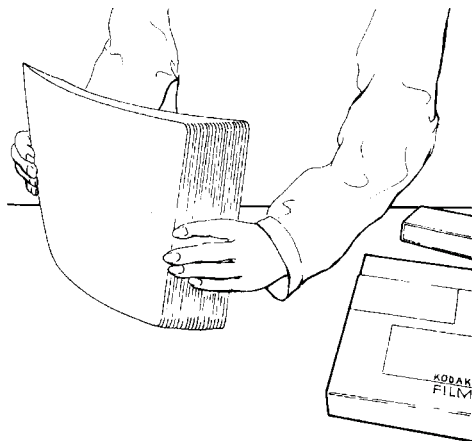

Remove any remaining films from the magazine. Push the new films all the way into the magazine. Place the films removed in the previous step on top of the new films. They should be used first.

**NOTE:**

**Single emulsion films must be loaded into the magazine with the emulsion up.**

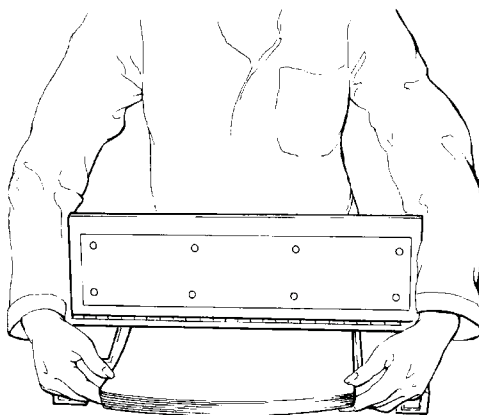

Close the magazine lid. You hear the latches “click”.

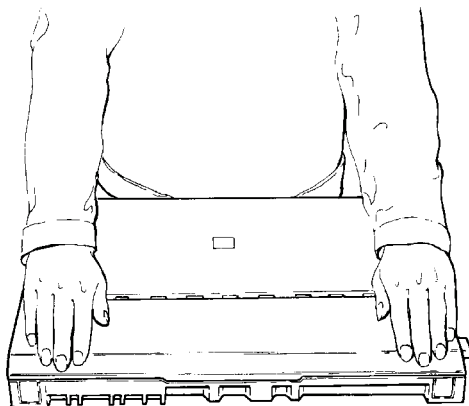

Open magazine door and insert magazine into the slot.  
Push it in all the way and press it down.

The magazine must fit beyond the black rollers. Close the magazine door.

The display will now show the film formats available.

## SPECIAL FUNCTIONS

---

Five soft switches are located immediately below the display. The lowest display line shows the function of the switches.

**LOAD, UNLOAD ONLY** and **SERIAL UNLOAD** may be selected by the soft switches on the front panel.

**UNLOAD ONLY** and **END OF SERIAL** unload will return the cassette either with the latch open or closed, depending on how it has been set on installation.

**TYPE 2** (alternative grade of film) may be selected manually via soft switch or automatically by coded cassettes.

### LOAD ONLY

---

When the KODAK X-OMAT Multiloader 300 Plus is ready for operation, you may select the "LOAD ONLY" mode by pressing <LOAD>.

The display will show the following:

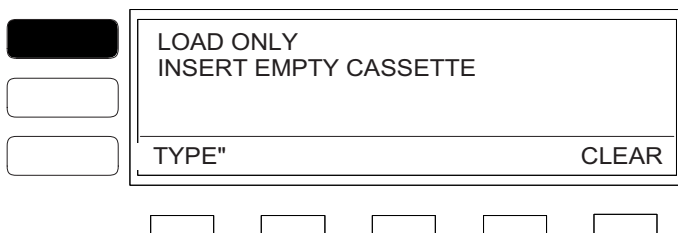

If you want to load a cassette with "Type 2" film, press <TYPE 2>.

- An inserted cassette will be loaded only.
- The KODAK X-OMAT Multiloader 300 Plus checks whether a film is in the cassette. If the cassette contains a film, a message will be displayed and an audible alarm will sound. The film will be transported to the processor and the cassette loaded. Press <CLEAR>. This will stop the alarm.
- The cassette is loaded as requested.

## UNLOAD ONLY

---

If the KODAK X-OMAT Multiloader 300 Plus is ready for operation you may select the "UNLOAD ONLY" mode by pressing <UNLOAD>.

The display will show the following:

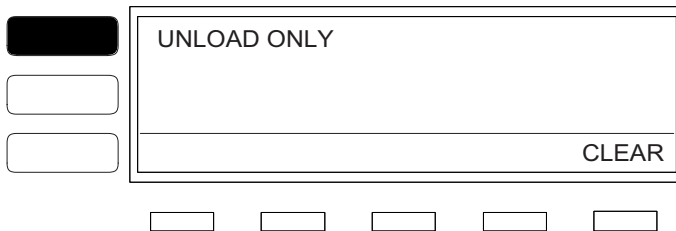

- An inserted cassette will be unloaded only.
- The cassette is returned either with the latch open or closed (depending on how it has been set on installation).
- If the cassette was inserted empty for UNLOAD ONLY, a message will be displayed and an audible alarm will sound. Press <CLEAR>. This will stop the alarm.

## SERIAL UNLOADING

The SERIAL UNLOADING function permits continuous unloading of a magazine into the integrated KODAK X-OMAT 3000 RA Processor using an empty cassette in the KODAK X-OMAT Multiloader 300 Plus.

### NOTE:

Before using the function SERIAL UNLOADING, increase the dryer temperature by approx. 5°C (9° F).

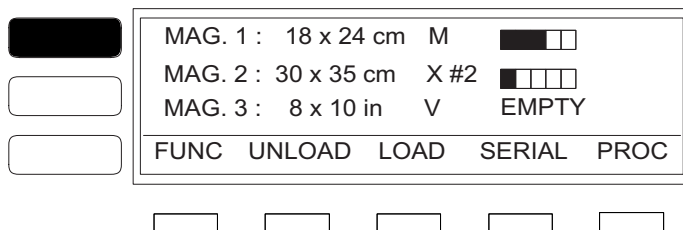

## PROCEDURE

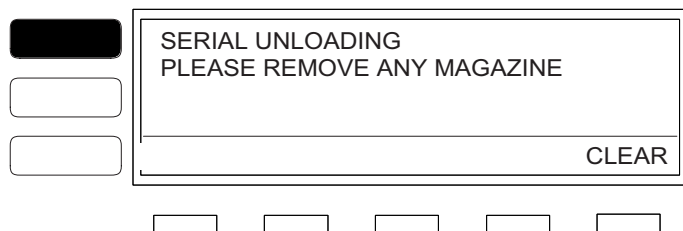

Press <SERIAL>. If there is no magazine level free, the following screen will be displayed:

Remove a magazine. The next magazine inserted will be identified as **SERIAL UNLOADING** magazine.

If there is at least one magazine level free when pressing <SERIAL>, the following screen will be displayed immediately:

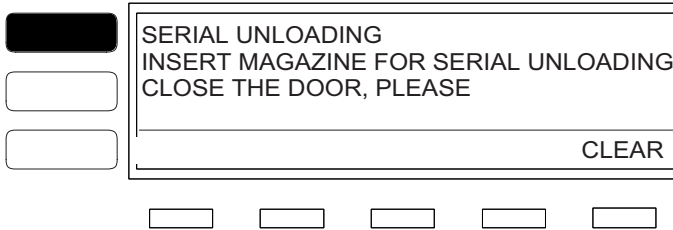

After closing the door the appropriate empty cassette is requested.

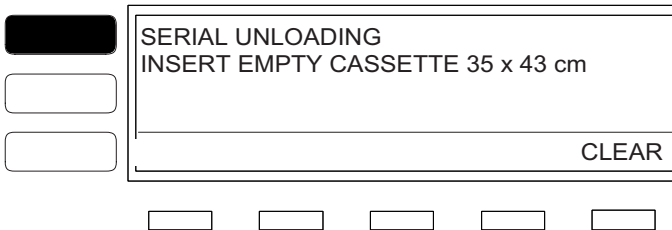

**NOTE:**

The KODAK X-OMAT Multiloader 300 Plus will check whether the inserted cassette is empty.

Should it not be empty, **NO MESSAGE WILL BE GIVEN.**

The film (exposed or not) will be unloaded, and **SERIAL UNLOADING** started.



During the unload cycle a count of the films removed from the magazine is displayed.

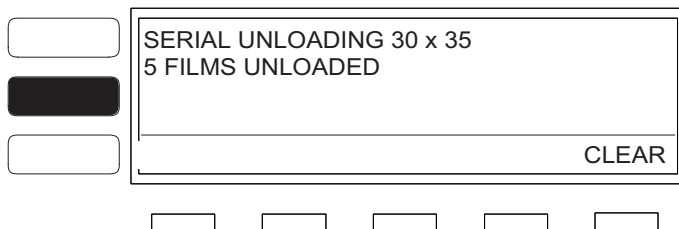

When the magazine is empty, the display shows the following screen. The cassette is returned empty and unlatched.

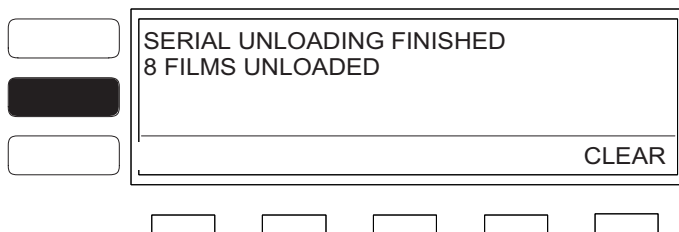

Removing the cassette or pressing <CLEAR> will lead to the standard menu.

Pressing <CLEAR> interrupts the **SERIAL UNLOAD** process and offers normal use for emergency films.

After pressing <CLEAR> the second time, the main menu will be displayed, and the emergency cassette can be inserted.

The serial unload magazine will remain in that status and be indicated on the main display as SU.

Pressing <SERIAL> again the KODAK X-OMAT Multiloader 300 Plus will return to **SERIAL UNLOADING**, and the display will ask for the empty cassette.

**NOTE:**

Set the dryer temperature back to the normal value after **SERIAL UNLOADING** has been finished and before you carry on with other functions.

**FUNCTION**

FILM TYPE 2, FILM USAGE, LANGUAGES.

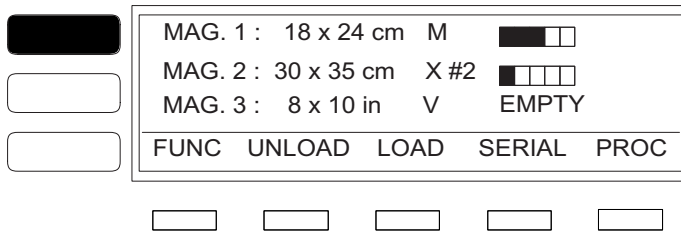

After pressing <FUNC> the display will show the following:

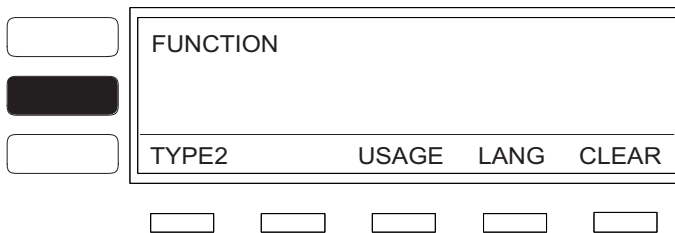

## FILM TYPE 2

---

The KODAK X-OMAT Multiloader 300 Plus may be "loaded" with either of two different film types of the same size.

In order to prevent a film mix up, the cassettes and magazines used for film TYPE 2 must be coded by your KODAK SERVICE PROVIDER, or a trained key operator.

The KODAK X-OMAT Multiloader 300 Plus will then automatically recognize the special cassette and load it with the special film without having to press <TYPE 2>.

Should it be necessary to load cassettes without codes, <TYPE 2> must be pressed.

The selected special function is valid only for the current cycle.

After removing the cassette from the entrance slot, the KODAK X-OMAT Multiloader 300 Plus will return to normal mode.

## FILM USAGE

After pressing <USAGE> the display will show the following:

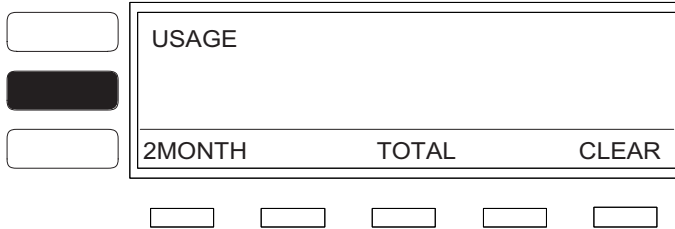

This function offers statistics by pressing the following:

<2MONTH>

number of films used during the current and the previous month by size and by type.

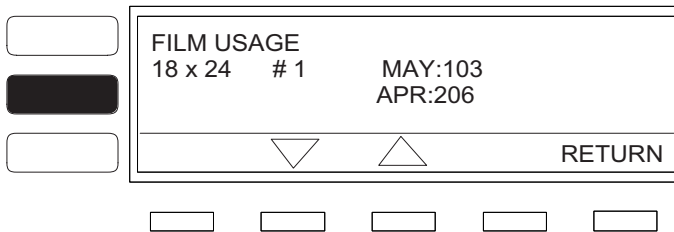

SOFT SWITCH

Scrolling up with SOFT SWITCH  $\Delta$  and down with SOFT SWITCH  $\nabla$  will display the other sizes.

&lt;TOTAL&gt;

number of films used last year and this year.

<input type="text"/>	GRAND TOTAL: SINCE JAN/01/98 XXXXXX LAST YEAR
<input type="text"/>	
<input type="text"/>	RETURN

Pressing <CLEAR> the display will always return to the main menu.

**NOTE:**

If the **SOFT SWITCHES** are not used for more than 20 seconds while using the statistic options, the display will return to the main menu.

## LANGUAGES

The KODAK X-OMAT Multiloader 300 Plus offers messages in 12 different languages.

English	Finnish
French	Norwegian
German	Spanish
Italian	Swedish
Danish	Portuguese
Dutch	Japanese

A maximum of 4 languages can be displayed. The selection will be made during installation. To change the language press <LANG> .

The display will show the following:

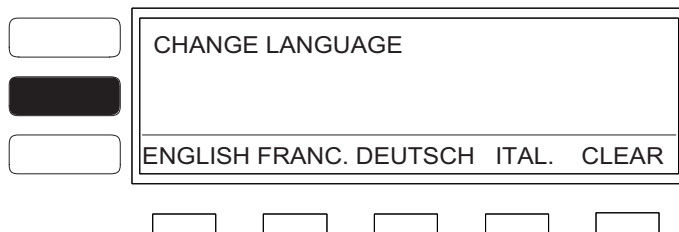

Select the desired language SOFT SWITCH. After the selection the display returns to the main menu.

Press <CLEAR> if you want to cancel your decision.

## ERROR MESSAGES

Message Displayed	Explanation
EXPOSED FILM NOT REMOVED. PLEASE CHECK CASSETTE IN DARKROOM.	The cassette may be empty and the user did not choose the <LOAD ONLY> mode. The machine feeds the cassette back, because a film could be sticking to the upper screen.
CASSETTE WAS NOT EMPTY. EXPOSED FILM WAS REMOVED.	The special function <LOAD ONLY> was selected, but a film was in the cassette when it was entered. During <SERIAL UNLOADING> a cassette containing a film was inserted.
MAGAZINE FOR SERIAL UNLOADING NOT DEFINED.	The magazine for <SERIAL UNLOADING> was not defined.
PLEASE INSERT CORRECT CASSETTE SIZE XX * YY	The cassette entered was incorrect for <SERIAL UNLOADING>.
EXPOSED FILM NOT REMOVED. PLEASE RE-ENTER CASSETTE.	Cassette was incorrectly inserted. If the message appears repeatedly, check the cassette in the darkroom. If there is no film in the cassette, have it checked by your KODAK SERVICE PROVIDER.
FILM SIZE/TYPE NOT AVAILABLE.	The chosen magazine is not available or used for <SERIAL UNLOADING>.
FILM SIZE/TYPE NOT AVAILABLE. MAGAZINE XX*YY EMPTY	The chosen magazine was empty when cassette was inserted. The cassette is RETURNED (with latch open or closed, depending on how it has been set on installation), as no film was loaded.
PLEASE CHECK CORRECT MAGAZINE INSERTION.	The magazine is probably not positioned correctly.
PLEASE INSERT CORRECT CASSETTE SIZE.	<SERIAL UNLOADING>. The cassette was unloaded and reloaded.
REMOVE AND CHECK MAGAZINE	If no film was removed from the magazine.

Message Displayed	Explanation
PLEASE RIFFLE FILMS IN MAGAZINE.	The films in the magazine adhere to each other, so that no single sheet of film can be removed from the magazine. In the darkroom remove and riffle the films before reloading the magazine.
PLEASE CHECK CASSETTE IN DARKROOM.	<p>a) If there is no film in the cassette have your KODAK SERVICE PROVIDER check the cassette.</p> <p>b) If there is a film in the cassette, the cassette is likely to have contained two films and one was removed in the KODAK X-OMAT Multiloader 300 Plus.</p>
UNEXPOSED FILM LOST.	Cassette closing problem. Cassette returned (either with latch open or closed depending on the setting during installation).
CASSETTE OUT TRANSPORT FAILED. OPEN COVER TO REMOVE FILM. EXPOSED FILM LOST.	<p>When cassette was opened the film was not removed and the closing mechanism does not reach the bottom dead centre.</p> <p>ASSUMPTION: A film is caught in the lightlock of the cassette. Open the top cover of the KODAK X-OMAT Multiloader 300 Plus to remove the film (see instructions on page 35). <b>The exposed film is lost now.</b></p>
CASSETTE OUT TRANSPORT FAILED . OPEN COVER TO REMOVE CASSETTE.	Cassette got stuck when it should have been fed out. In this case open the top cover of the KODAK X-OMAT Multiloader 300 Plus to remove the cassette (See instructions on pages 35 and 36.
PLEASE CALL FOR SERVICE.	If this message appears, inform your KODAK SERVICE PROVIDER, as these problems can only be solved by him.*

\* On installation you can, however, have the KODAK SERVICE PROVIDER adjust the unit in such a way that the operator will be able to clear **every** error message by pressing <CLEAR>.



## HOW TO REMOVE A CASSETTE

---

To open top cover press button on the rear side.

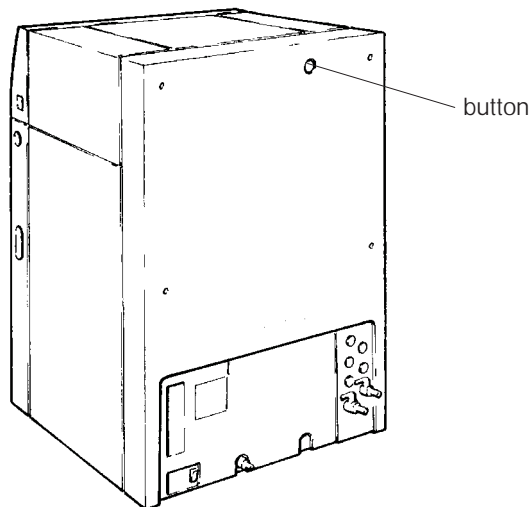

Lift and remove top cover.

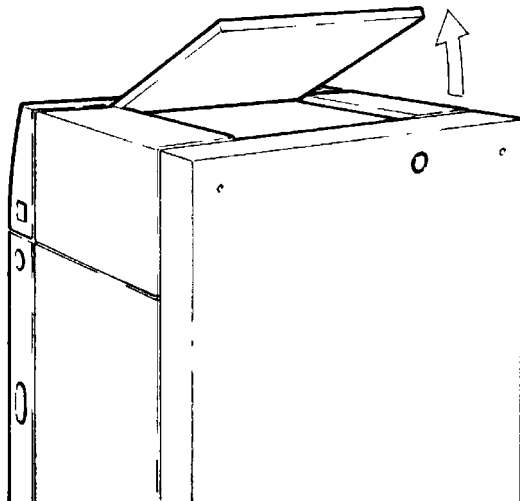

Release by pressing cassette lid. Push centering bars to full width. Lift out cassette.

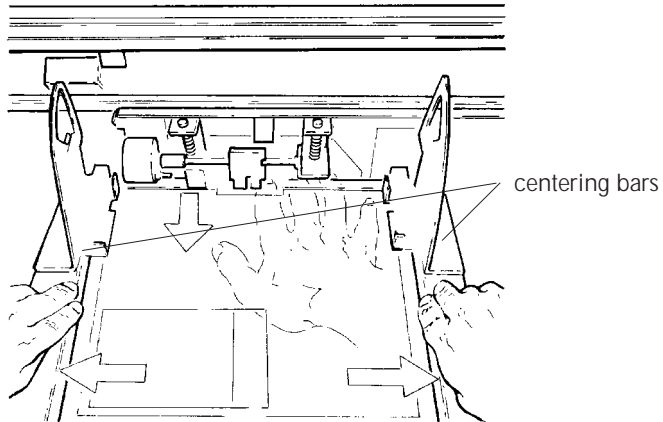

**NOTE:**

The 35 x 43 cm cassette will **NOT** lift out of the KODAK X-OMAT Multiloader 300 Plus. The cassette must be pushed through the entrance slot. First rotate knob to open shutter, then push cassette through entrance slot.

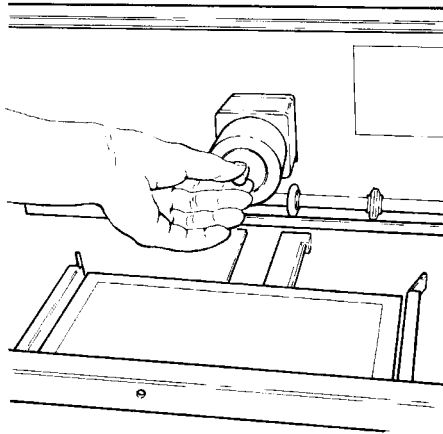

Close the top cover.

Press <RESET> on the display of the KODAK X-OMAT Multiloader 300 Plus.

## INTEGRATED KODAK X-OMAT 3000 RA PROCESSOR

The KODAK X-OMAT Multiloader 300 Plus incorporates a specially modified integrated KODAK X-OMAT 3000 RA processor. It requires minimal operator intervention and greatly reduced "house keeping" maintenance.

### THE DISPLAY

From the main menu press <PROC>, and the display will change to the main menu regarding the integrated KODAK X-OMAT 3000 RA Processor (this menu will be called the "main processor menu" in the following)

<input type="text"/>	PROCESSOR READY				STD
<input type="text"/>	127.4 F = DRYER TEMP		95.0 F = DEV TEMP		
<input type="text"/>	DRYER TEMP	SLEEP	SELECT CYCLE	MORE	DONE/ RETURN

This main processor menu consists of two parts. To get to the second part, press <MORE>.

<input type="text"/>	PROCESSOR READY				STD
<input type="text"/>	127.4 F = DRYER TEMP		95.0 F = DEV TEMP		
<input type="text"/>	DISPLAY FIX TEMP	TIME/ DATE	GO TO SETUP	DONE/ RETURN	

Select the required information from part one or two of the menu shown above.

(<GO TO SETUP> requires an access code available to trained "Key Operators" and service personnel).

## CHANGING THE DRYER TEMPERATURE

Select <DRYER TEMP> in screen 1 of the main processor menu, and in the new menu you can select the following keys:

- < " Δ " DRYER >      Pressing this key increases the dryer temperature.
- < " ▽ " DRYER >      Pressing this key reduces the dryer temperature.
- < DEFAULT SETTING >   Pressing this key returns the KODAK X-OMAT dryer to the default setting.
- < DONE/RETURN >      Pressing this key returns the display to the previous screen.

## CHANGING THE PROCESSING CYCLE

The integrated KODAK X-OMAT 3000 RA Processor offers 4 cycles to process film in the processor: extended, standard, rapid, and K/RA cycle. Extended (<EXTD CYCLE>), standard (<STD CYCLE>), and rapid cycle (<RAPID CYCLE>) can be selected as follows:

1. Press <SELECT CYCLE> in screen 1 of the main processor menu.

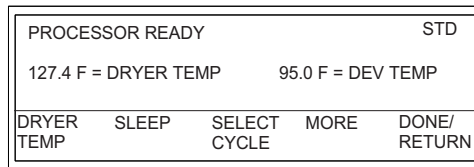

2. Press the appropriate key for the required cycle.

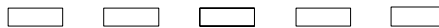
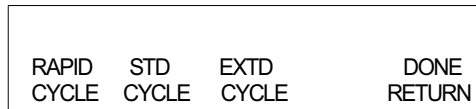

3. Repeatedly press <DONE/RETURN> until you return to the main processor menu.

### NOTE:

**K/RA cycle is not available from this menu, as special chemicals and films are required. This cycle may only be selected by trained personnel.**

## CYCLE INFORMATION FOR THE INTEGRATED KODAK X-OMAT 3000 RA PROCESSOR

Cycle	Process Time in seconds	Drop Time in seconds	Film and Chemicals	Throughput films/hour
K/RA USA	48	58	RA Film and Chemicals	270
K/RA outside USA	64	77	RA Film and Chemicals	201
Rapid	64	77	RA or RP Film/ RP Chemicals	201
Standard	86	105	RA or RP Film/ RP Chemicals	148
Extended	169	206	RP Film and Chemicals	74

**Cycle** as used in this table, refers to the film processing cycle that is currently selected.

**Process Time** refers to the time it takes the leading edge of a 35 x 43 cm (14 x 17 in.) sheet of film to travel from the entrance rollers to the exit rollers of the dryer rack.

**Drop time** refers to the time from the leading edge of a 35 x 43 cm (14 x 17 in.) sheet of film fed 43 cm wide entering the entrance rollers until the trailing edge exits the dryer rack.

**Film and chemicals** refer to the combination of film and chemicals required for optimum image quality when using the integrated KODAK X-OMAT 3000 RA Processor. KODAK RP X-OMAT Developer Replenisher and KODAK RP X-OMAT Fixer and Replenisher, or equivalents, may be used with the extended, standard, and rapid cycles. Only KODAK RA X-OMAT Films and Chemicals may be used for the K/RA cycle. Contact your KODAK SERVICE PROVIDER to discuss the best option for your needs.

**Throughput** refers to the number of 35 x 43 cm (14 x 17 in.) sheets of film fed 43 cm wide that can be processed in one hour.

Changing between EXTND and STD requires no waiting time, but from EXTND and STD to RAPID requires approximately 5 minutes for the temperatures to change and stabilize. From RAPID to STD or EXTND requires approximately 15 minutes for the temperatures to reduce.

The cycle will be shown on the display of the KODAK X-OMAT Multiloader 300 Plus.

Replenisher rates, speed and temperatures are automatically adjusted for the chosen cycle.

## ENTERING AND EXITING SLEEP MODE

When the processor is in sleep mode, it appears to be „off,“ but the microprocessor remains active. Depending upon the configuration of other options, heaters, motors, and solenoids remain off while the processor is in sleep mode. While the integrated KODAK X-OMAT 3000 RA Processor is in sleep mode, you cannot feed films or access any of the processor setup screens.

### Procedure for Entering Sleep Mode:

Press <SLEEP> in screen 1 of the main processor menu.

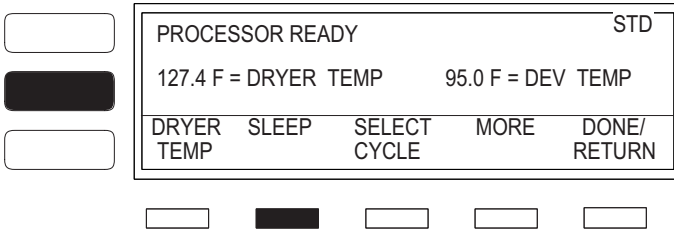

Press <YES> to place the processor into the sleep mode, or <CANCEL REQUEST> to quit.

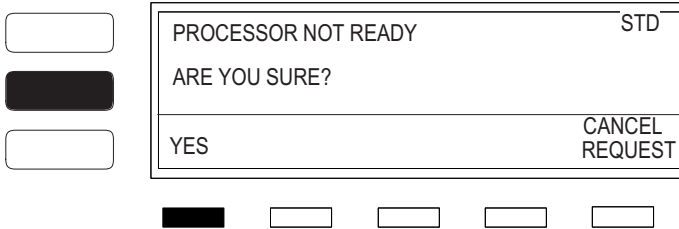

If you have programmed the Automatic On and Off Timers under the „AUTO STARTUP“ menu, the screen below will be displayed when the integrated KODAK X-OMAT 3000 RA Processor enters Sleep Mode. The screen remains displayed until the Automatic Timer turns on, or until you press <WAKE>.

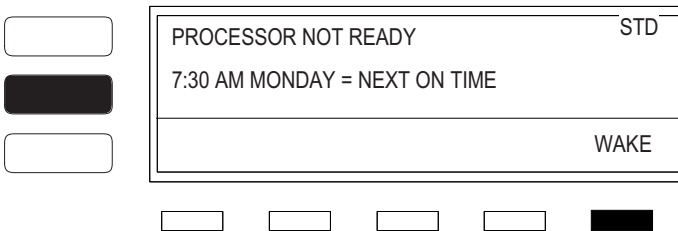

If you have not programmed the Automatic On and Off Timers, the display will show the message „PROCESSOR IN SLEEP MODE.“

### Procedure for Exiting Sleep Mode:

There are two different ways to take the integrated KODAK X-OMAT 3000 RA Processor out of sleep mode:

1. If you have programmed the Automatic On and Off Start-Up Timers, you can allow the pre-programmed On Timer to return the integrated KODAK X-OMAT 3000 RA Processor to normal operating condition at the specified time.
2. Press <WAKE> on the following menu:

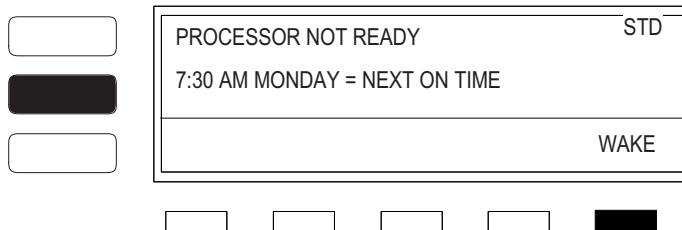

### DISPLAYING THE FIXER TEMPERATURE

To display the temperature of the fixer solution, simply press <DISPLAY FIX TEMP> on screen 2 of the main processor menu. The temperature reading will then be displayed for the fixer solution.

#### NOTE:

**The setpoint temperature for the fixer solution is a minimum only; the temperature may rise above this setpoint.**

To return to the main processor menu, press <DONE/RETURN>.

### DISPLAYING THE TIME AND DATE

If you wish to display the current time and date, simply press <TIME/DATE> on the display panel. Current time and date will then be displayed.

To return to the main processor menu, press <DONE/RETURN>.

## CLEAN-UP AND PREVENTATIVE MAINTENANCE

---

### WEEKLY CLEAN-UP AND MAINTENANCE OF THE INTEGRATED KODAK X-OMAT 3000 RA PROCESSOR

---

The information below outlines the recommended maintenance procedures to keep your integrated KODAK X-OMAT 3000 RA Processor operating properly. Reliable operation of the integrated KODAK X-OMAT 3000 RA Processor requires that you clean, adjust and lubricate all parts correctly. More frequent maintenance may be necessary because of site conditions or actual usage. For monthly and quarterly maintenance, contact your trained service personnel.

#### WARNINGS:

**Dangerous voltage.**

**Always disconnect the main power (power plug and wall mounted circuit breaker) before performing any of the following weekly procedures.**

**Only personnel trained by Kodak for this purpose may carry out the following steps.**

**Wear rubber gloves, safety glasses, and protective clothing when doing the weekly maintenance. Report any change in the operating condition of the integrated KODAK X-OMAT 3000 RA Processor to your service personnel.**

1. Disconnect the main power.
2. Release the latches. Slide out the integrated KODAK X-OMAT 3000 RA Processor GENTLY to avoid splashing.

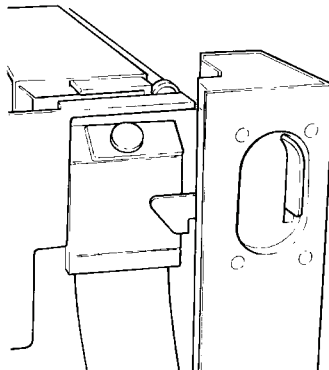



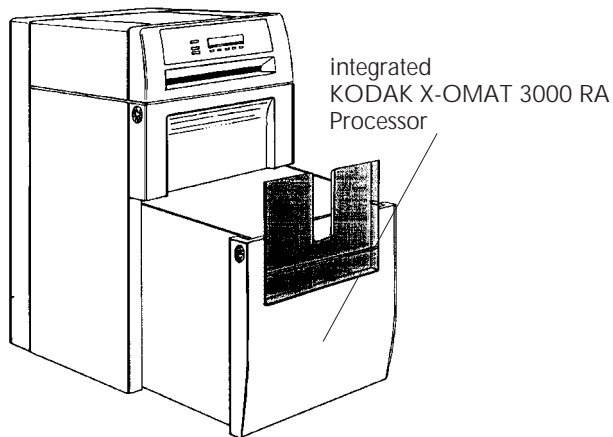

**CAUTION:**

Handle these assemblies carefully to prevent changing the alignment.

Use a synthetic sponge and warm water.

**Do not** wash the racks and crossovers with water hotter than 44°C (110°F).

**Do not** clean the racks, crossovers, or squeegee rollers using abrasive materials or alcohol.

To prevent fixer or developer contamination when removing the fixer or developer rack, place the splash guard between the developer and fixer tanks. Use the rack drip tray when you remove or install any of the racks.

splash guard

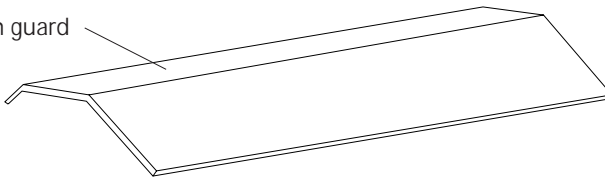

rack drip tray

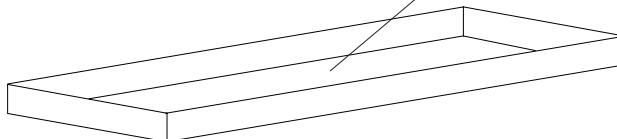

3. Remove the following parts from the integrated KODAK X-OMAT 3000 RA Processor (see illustrations below):
  - \* Wet section cover
  - \* Evaporation covers
  - \* Water reservoir
  - \* All crossovers
  - \* Wash rack

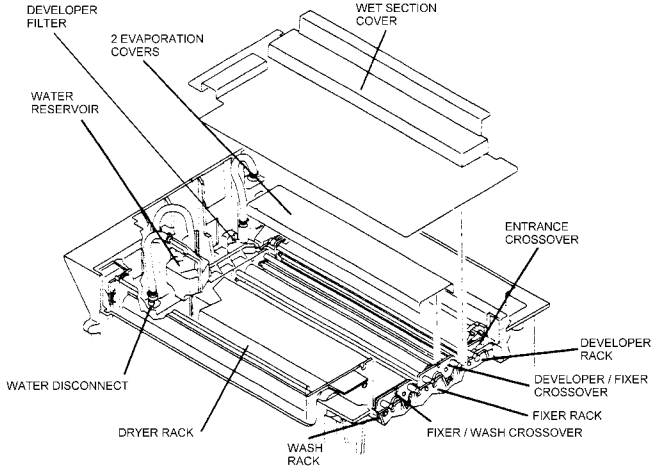

4. Rinse the 3 crossovers, troughs, water reservoir, and the wash rack with warm water, no hotter than 44°C (110°F). Wipe the rollers and the guide shoes with a damp, soft, synthetic sponge.

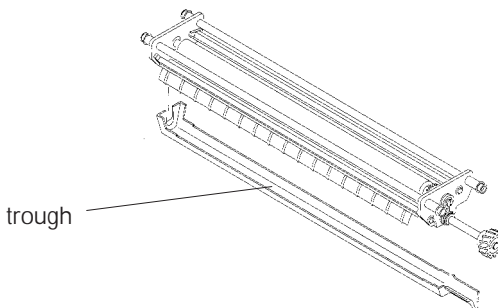

5. Allow the entrance crossover to air dry before you install it in the integrated KODAK X-OMAT 3000 RA Processor.
6. Wipe any chemical deposits from the processing section of the integrated KODAK X-OMAT 3000 RA Processor.

7. Check that all rollers on all crossovers and on the wash rack rotate freely. Check the squareness of the crossovers and the wash rack.
8. Check that the crossover troughs are not broken or cracked.
9. Install the following parts into the integrated KODAK X-OMAT 3000 RA Processor (see illustration on page 1-44).  
Check that each assembly is firmly seated.
  - \* Wash rack
  - \* All crossovers
  - \* Water reservoir
  - \* Evaporation covers
  - \* Wet section cover
10. Carefully push the integrated KODAK X-OMAT 3000 RA Processor back into the KODAK X-OMAT Multiloader 300 Plus until the latches "click".

**CAUTION:**

**To reduce/minimize the possibility of personal injury when rolling in the integrated KODAK X-OMAT 3000 RA Processor into the KODAK X-OMAT Multiloader 300 Plus, the following procedure should be followed.**

To close the processor section:

Pull the processor approx. 1 in. (2,5 cm) further open to release the tension on the stop bracket, and hold the processor in this position.

Push the stop bracket toward the processor rack section, and momentarily hold it in this position as you move the processor approx. 2 in. (5 cm) toward the closed position.

Stop moving the processor.

Before moving the processor any further, move your hands away from the stop bracket. Place both hands on the front surface of the processor where they will not be subject to contact with any moving parts.

Gently push the processor to the closed position, until the latches click into position.

11. Turn on the integrated KODAK X-OMAT 3000 RA Processor and the KODAK X-OMAT Multiloader 300 Plus and check for correct operation.
13. Process a test film.

## MAINTENANCE OF THE HUMIDIFIER

---

(Every 6 months):

Should your KODAK X-OMAT Multiloader 300 Plus be equipped with a humidifier, please pay attention to the following:

The filter cartridge of the humidifier has to be exchanged at least every 6 months, or as needed. For that purpose, please inform Kodak authorised service personnel.

**WARNING:**

**The replacement of the humidifier filter cartridge has to be carried out by Kodak authorised service personnel.**

## WARRANTY

---

Kodak warrants this KODAK X-OMAT Multiloader 300 Plus to function correctly for one year from the date of initial installation, when installed within one year from date of shipment.

### Warranty Repair Coverage

If this equipment does not function correctly during the warranty period, the service provider (for KODAK X-OMAT Multiloaders 300 Plus) who sold the equipment will provide or arrange for repair of the equipment during the dealer's normal working hours. Such repair service will include any adjustments and/or replacement of parts required to maintain your equipment in good working order.

### How To Obtain Service

Should the equipment require service, refer to the sales contract for details on whom to call for service, or contact the service provider (for KODAK X-OMAT Multiloaders 300 Plus) who sold the equipment.

### Limitations

Warranty service is limited to the contiguous United States, the island of Oahu in Hawaii, and certain areas of Alaska.

### This warranty does not cover—

- circumstances beyond the control of Kodak
- misuse
- abuse
- attachments
- accessories
- alterations not marketed by Kodak (including service or parts to correct problems resulting from the use of such attachments, accessories, or alterations)
- failure to follow the operating instructions recommended by Kodak
- supply items

**Kodak makes no other warranties, express or implied, for this equipment.**

**Repair without charge is the only obligation of both Kodak and the dealer under this warranty. Kodak will not be responsible for any consequential or incidental**

**damages resulting from the sale, use, or improper functioning of this equipment, even if loss or damage is caused by the negligence or other fault of Kodak.**

Such damages for which Kodak will not be responsible, include, but are not limited to, loss of revenue or profit, downtime costs, loss of use of the equipment, cost of any substitute equipment, facilities or services or claims of your customers for such damages.

This limitation of liability will not apply to claims for injury to persons or damage to property caused by the sole negligence or fault of Kodak or by persons under its direction or control.

## KEY OPERATOR INSTRUCTIONS

---

The Key Operator is a person with more experience than the casual user and has been specially trained by Kodak. Unlike the casual operator who can only use the equipment, the Key Operator may also carry out the steps described in this chapter 2. Due to his special training by Kodak, he knows the access code and can, therefore, change factory settings.

### RESIZING MAGAZINES

---

When a new film size has to be used in the KODAK X-OMAT Multiloader 300 Plus you can code any magazine to hold the new film size. The following sizes can be used.

Additionally, it is also possible to code each size from the list below as a type 2 film.

X-OMATIC FILM	MAMMOGRAPHY FILM	CRT FILM
18 x 43 cm 20 x 40 cm 24 x 24 cm 24 x 30 cm 18 x 24 cm 30 x 35 cm 30 x 40 cm 35 x 35 cm 35 x 43 cm 8 x 10 inch 10 x 12 inch 11 x 14 inch	18 x 24 cm 24 x 30 cm	8 x 10 inch

1. Remove the cover of the magazine as shown in the illustration below:

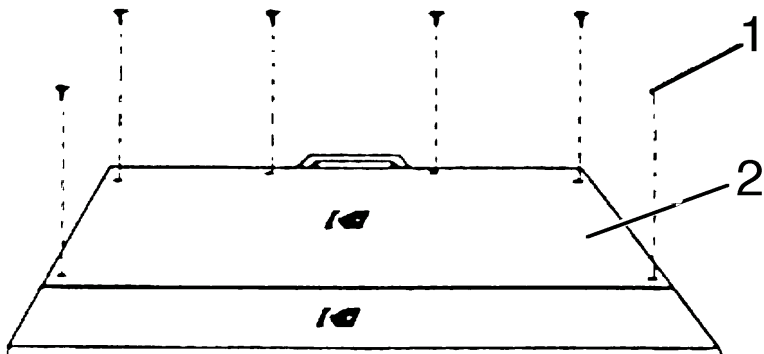

- 1 screw
- 2 cover

2. Place the stops in the recesses corresponding to the film size. The film sizes are marked in the recesses. If not all stops for the rear are needed place the surplus stops to the lefthand or righthand side in the magazine.

**IMPORTANT:**

The left and right stops have to be positioned with their noses as indicated in the picture.

Otherwise the magazine cannot be closed!

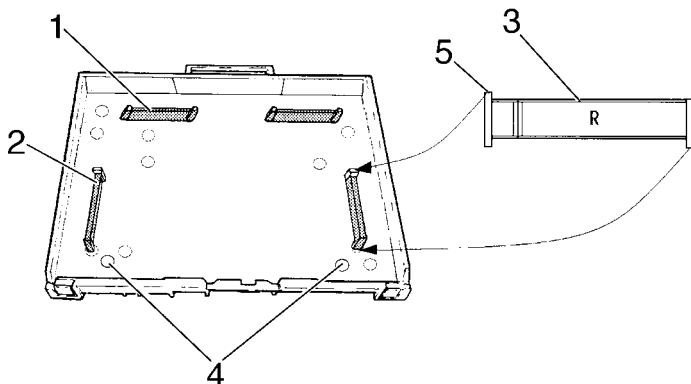

- 1 stop rear
- 2 stop left
- 3 stop right
- 4 recesses with film size
- 5 nose



3. Reinstall the cover of the magazine. The mechanical setting of the magazine is completed now.
4. To enable the KODAK X-OMAT Multiloader 300 Plus to decode the correct magazine size, you have to provide the magazines with code brackets.

The code brackets are easy to reach, if the magazine is placed upside down on a flat surface. The brackets can now be seen.

For the setting of the code brackets see next page.

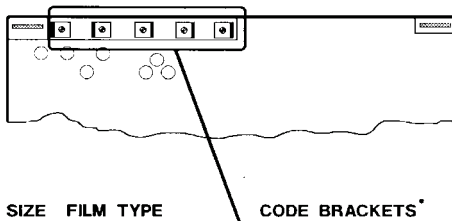

CASSETTE SIZE	FILM TYPE	CODE BRACKETS*				
18x24 cm	X-OMATIC FILM					
18x24 cm	MAMMOGRAPHY FILM					
18x43 cm	X-OMATIC FILM					
20x40 cm	X-OMATIC FILM					
24x24 cm	X-OMATIC FILM					
24x30 cm & 10x12 in	X-OMATIC FILM					
24x30 cm	MAMMOGRAPHY FILM					
30x35 cm & 11x14 in	X-OMATIC FILM					
30x40 cm	X-OMATIC FILM					
35x35 cm	X-OMATIC FILM					
35x43 cm	X-OMATIC FILM					
8x10 inch	X-OMATIC FILM					
8x10 inch	CRT FILM					
		1	2	3	4	5
TYPE 1 for all sizes						
TYPE 2 for all sizes						

\* CODE BRACKETS : = =

After the code brackets have been installed:

1. Open magazine door of KODAK X-OMAT Multiloader 300 Plus.
2. Insert the recoded magazine and close the magazine door.
3. Look at the display: Is the correct film size displayed?  
If not, take out the magazine and check the setting of the code brackets.
4. Load the recoded magazine with test films
5. Check whether there is too much play between the films and the stops in the magazine. There must not be more than appr. 4 mm clearance between the films and the stops. If the play is too great remove the films and check the setting of the stops inside the magazine.

Load the magazine with fresh films and insert the magazine into the KODAK X-OMAT Multiloader 300 Plus.

**IMPORTANT:**

**Use the magazine only if you are absolutely sure that the setting of the code brackets and the stops is correct.**

**Otherwise you can cause serious damage to the KODAK X-OMAT Multiloader 300 Plus.**

## TYPE 2 CODING OF CASSETTES

---

There are two ways of instructing the KODAK X-OMAT Multiloader 300 Plus to handle a cassette as a TYPE 2 Cassette:

1. Press <TYPE 2> on the front panel
2. A reflective patch on the top of the cassette; this cassette will always be handled as a TYPE 2 cassette.

The reflective patches can be ordered from Kodak under Part Number 9194551.

The KODAK MIN-R 2 an X-OMATIC Video Film Holder Cassette reflectors are very easy to place, as the correct position is marked by a recess on the top of the cassettes. For all other cassettes a template with part Number 9194501 is needed to place the reflector in the correct position.

## C1 CASSETTES

---

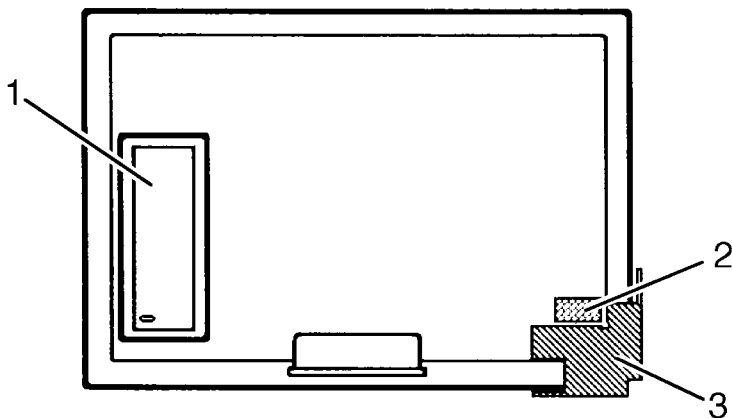

1. Window
2. Reflective Sticker 8 x 15 mm
3. Template 9194501

## C2 CASSETTES

---

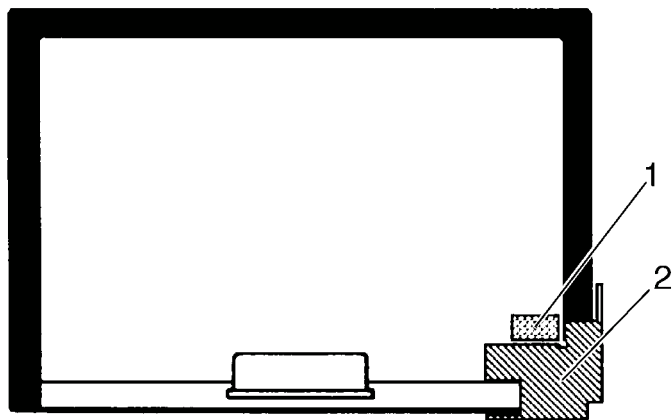

1. Reflective Sticker 8 x 15mm
2. Template 9194501

## C3 CASSETTES

---

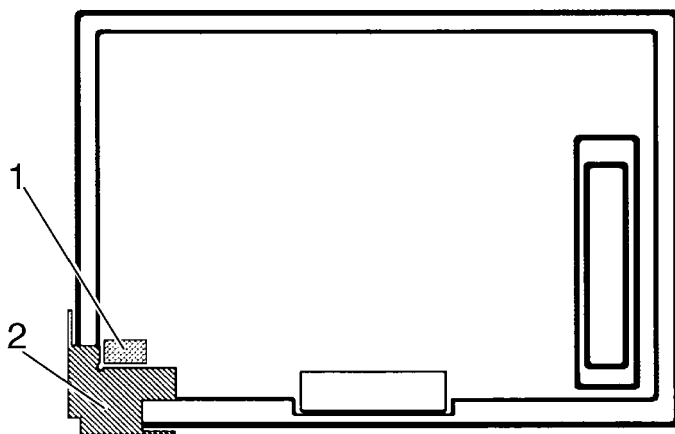

1. Reflective Sticker 8 x 15 mm
2. Template 9194501

## MIN-R 2 CASSETTE

### NOTE:

For TYPE 2 coding two REFLECTIVE STICKERS have to be installed to the MAMMOGRAPHY CASSETTE.

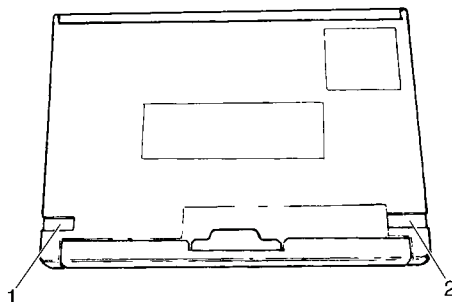

1. Reflective Sticker 8 x 15 mm
2. Reflective Sticker 8 x 15 mm

## KODAK X-OMATIC VIDEO FILM HOLDER

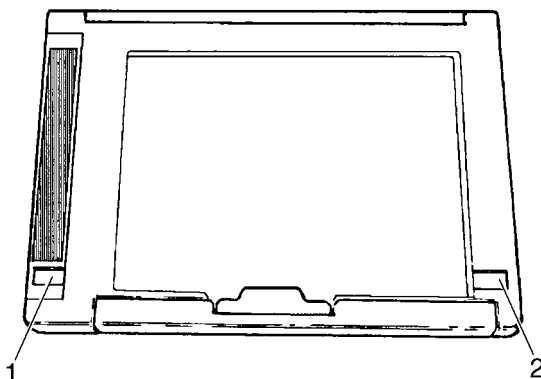

1. Reflective Sticker 8 x 15 mm - C3
2. Reflective Sticker 8 x 15 mm - C1

### NOTE:

At KODAK X-OMATIC Video Film Holders the REFLECTIVE STICKERS can be positioned either at the right or at the left side (C1 or C3).

## FAILURES AND ERROR HANDLING

The KODAK X-OMAT Multiloader 300 Plus is a microprocessor-controlled unit that minimizes the actions necessary to solve any possible problems in the unit. For any failure in the KODAK X-OMAT Multiloader 300 Plus the micro-processor will start an automatic error handling sequence.

The KODAK X-OMAT Multiloader 300 Plus will always try to save the exposed films. That means whenever a failure occurs during the cycle the KODAK X-OMAT Multiloader 300 Plus will try to unload the cassette, process the exposed film and feed out the cassette.

There are two groups of failures which can occur in the KODAK X-OMAT Multiloader 300 Plus\*:

1. Failures that can only be solved by your KODAK SERVICE PROVIDER.
2. Failures which can be corrected by the operator or by the KODAK X-OMAT Multiloader 300 Plus itself.

For any failure in the cycle of the KODAK X-OMAT Multiloader 300 Plus the error and the action to be taken will be displayed

As the display of the KODAK X-OMAT Multiloader 300 Plus consists of four lines only, insome cases it will take more than one screen to display the whole error message. In these cases the right hand key is used to obtain more information on the screen.



\* On installation you can, however, have the KODAK SERVICE PROVIDER adjust the unit in such a way that the operator will be able to clear **every** error message by pressing <CLEAR>.



At the end of the messages the following screen will appear:

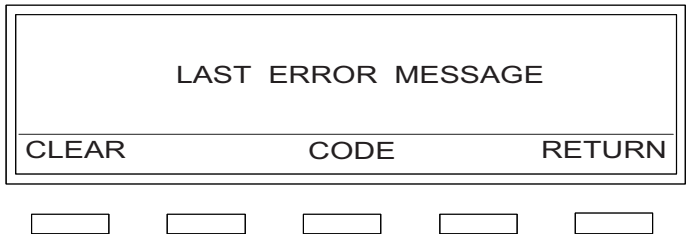



## FUNCTION BUTTONS

---

<CLEAR>

Press this button after you followed any steps you were told to perform in the error message (if there were any). After this button has been pressed the KODAK X-OMAT Multiloader 300 Plus will bring all motors to home position and check their functions. If this procedure was successful the green status light will appear, and you can start working again with the KODAK X-OMAT Multiloader 300 Plus.

If this automatic test was not successful, an error message will appear again, and in critical failures also the advice to call for service personnel as serious failures are too difficult to be solved by the operator.

<RETURN>

After pressing this button the first display of the error message appears once more, and you can move through the whole message again.

<CODE>

To give your KODAK SERVICE PROVIDER information concerning the failures which occurred this key should be pressed.

A code will appear on the display. Please write down this code completely, and pass it on to the service personnel as soon as you call for service. With the computer aided diagnostic system the service person can check the possible causes of the failures in advance.

With this procedure Kodak is able to minimize the down time of the unit.

As long as the error code is displayed <CLEAR> and <RETURN> will also appear. They have the functions as explained above.

## KODAK X-OMAT MULTILOADER 300 PLUS KEY OPERATOR INSTRUCTIONS .....

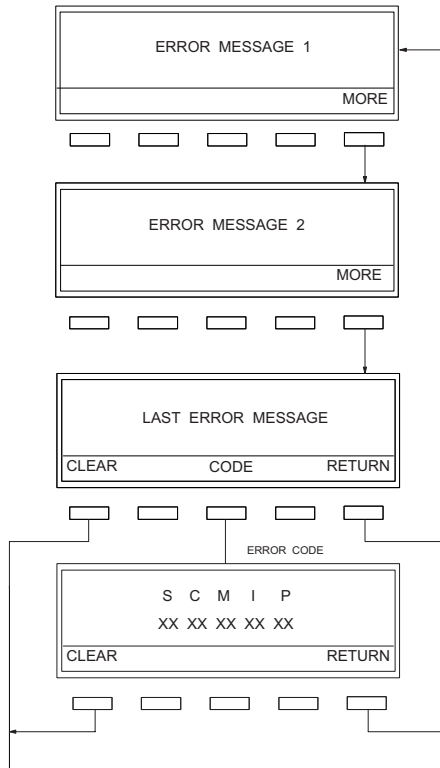

### AUTOMATIC RESET OF THE KODAK X-OMAT MULTILOADER 300 PLUS

If successful: the unit will be ready for operation again.

If not successful: call for service.

## FAILURES NOT DETECTED BY THE KODAK X-OMAT MULTILOADER 300 PLUS . . . . .

Most of the possible failures of the KODAK X-OMAT Multiloader 300 Plus are detected by the unit itself. Only the following few are not detectable.

### Failures:

Wrong film

### Causes:

Is the correct size displayed by the KODAK X-OMAT Multiloader 300 Plus?

Are all magazines seated correctly?

Check the code brackets of the magazines (see magazine coding).

### Further possible causes:

Code bracket is broken.  
Order new bracket with P/N 918 9532 (Screw 430 2346).  
Install new brackets.

If code brackets are intact; but wrong size detection:

Move magazine to another level. By moving the magazine to another level, the problem of the wrong size detection might be solved, although there is a failure in the size detection. Please inform your KODAK SERVICE PROVIDER of this failure.

If magazine detection is o.k.:

Are your cassettes o.k.?

**Failures:**

Message:

Type 1 film loaded  
in a Type 2 coded  
cassette.

**Causes:**

If the cassette edges are damaged, have the cassette checked  
by your KODAK SERVICE PROVIDER  
If cassette and magazine detection are ok, call your KODAK  
SERVICE PROVIDER.

Are the reflectors on the cassette dirty or damaged?  
If so, replace reflectors (see type 2 coding of cassettes).

If not, call your KODAK SERVICE PROVIDER.  
In the meantime, use the soft key for TYPE 2 selection.

## USING THE ACCESS CODE

Only your KODAK SERVICE PROVIDER and Key Operator should have use of the access code. The Key Operator receives the access code after he has been especially trained by KODAK. The access code must be entered after the <GO TO SETUP> key (screen 2 of the main processor menu) has been pressed.

The access code is necessary to:

- change set-up information preset at the factory, and
- change to or from the "K/RA" cycle.

If the Limited Access Feature is off, an access code is not necessary to perform the functions listed below:

- to select processor cycles (except "K/RA"),
- to change dryer temperature, or
- to display fixer temperature,
- to place the Processor in the Sleep Mode,
- to display the time and the date.

To come to <GO TO SETUP> on the main processor menu press <PROC>.

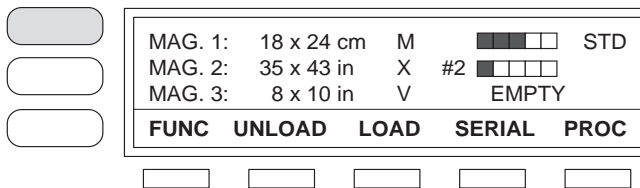

You will then come to screen 1 of the main processor menu (all descriptions on the following pages start with this menu):

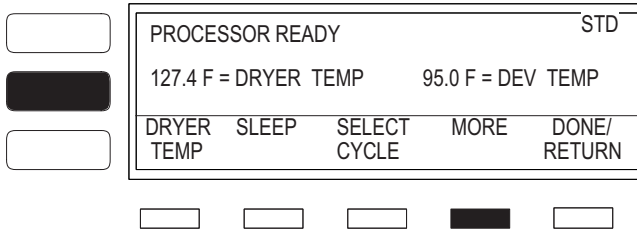

To reach the <GO TO SETUP> key on screen 2 of the main processor menu, you have to press <MORE>.

Screen 2 of the main processor menu:

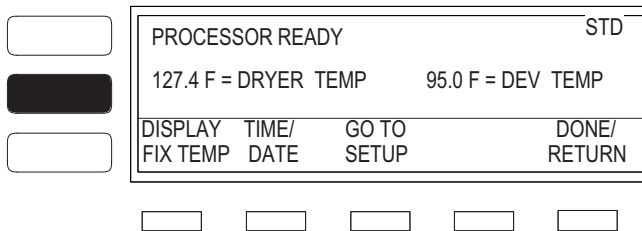

## MIXING THE CHEMISTRY

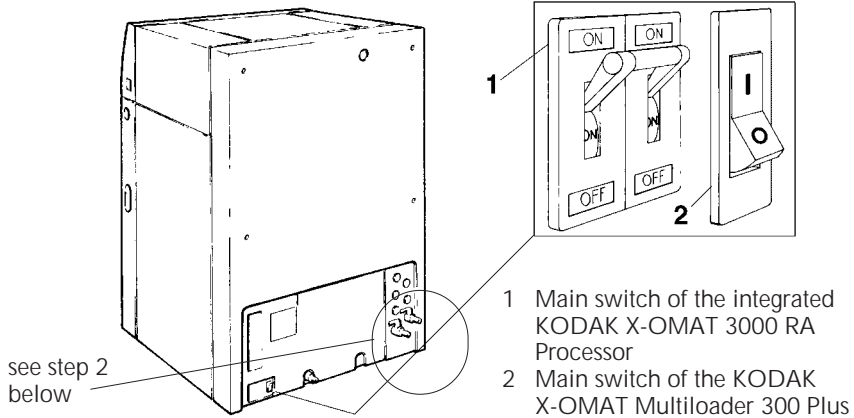

1. Move the main switch of the integrated KODAK X-OMAT 3000 RA Processor to the "OFF" position.
2. Make sure that the developer (7) and fixer (9) drain valves are closed.

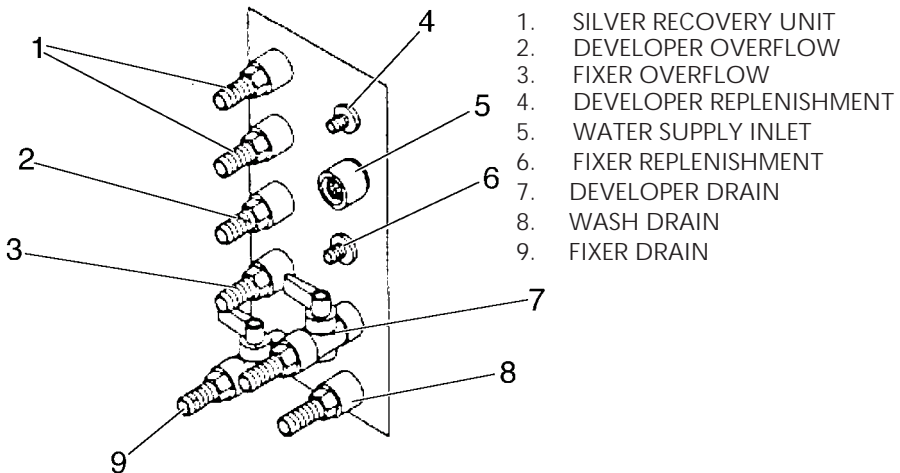

- Determine which type of chemistry is needed for the operating cycle that you selected.

Cycle	Film/Chemicals
K/RA	RA film/RA chemicals
RAPID	RA film/RP chemicals
STANDARD	RP film/RP chemicals
EXTENDED	RP film/RP chemicals

**IMPORTANT:**

**When mixing chemistry, follow all instructions and precautions.  
Mix only a 2 week supply of developer and fixer replenishment.**

**WARNING:**

**Wear rubber gloves, safety glasses, and protective clothing  
when mixing chemistry.**

- Follow all directions provided with the solutions, mix at least 19 liters (5 gallons) of solution.



## FILLING THE TANKS OF THE INTEGRATED KODAK X-OMAT 3000 RA PROCESSOR

The **TANK FILL MODE** must be selected when you want the processor tanks to fill automatically. In this mode the processor tanks fill with solution from the replenishment tanks until the level sensors detect that the processor tanks are full.

1. Release the latches. Slide out the processor GENTY to avoid splashing, and check that the racks are in the correct position.(see description in chapter CLEAN-UP AND PREVENTATIVE MAINTENANCE on page 1-42).

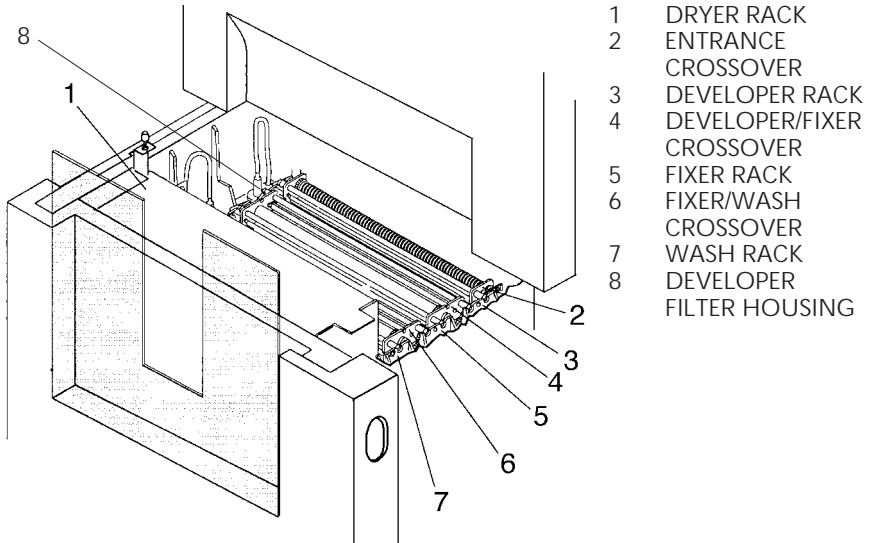

2. Push the processor back into the KODAK X-OMAT Multiloader 300 Plus.

### CAUTION:

To reduce/minimize the possibility of personal injury when rolling in the integrated KODAK X-OMAT 3000 RA Processor into the KODAK X-OMAT Multiloader 300 Plus, please follow the description given on page 1-45 of this manual.

3. Move the processor main switch to the "ON" position.

### IMPORTANT:

The replenisher pumps automatically start when the processor is turned on.

4. Wait for the main menu of the KODAK X-OMAT Multiloader 300 Plus to appear on the display panel. Then press <PROC>.
5. Press <MORE> in screen 2 of the main processor menu.

5. Press <GO TO SETUP> on the screen 2 of the main processor menu.

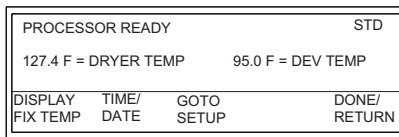

6. Enter the 4-digit access code.

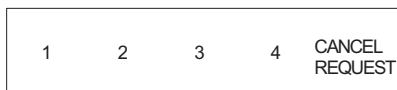

7. Press <MORE>.

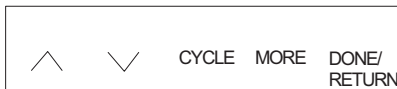

8. Press <OPTIONS>.



9. Press <REPLEN MODE>.



10. Press <TANK FILL>. (See important note on the next page.)

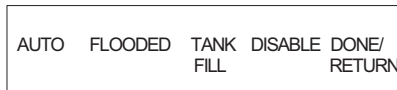

**IMPORTANT:**

If the developer and fixer tanks of the processor are empty and you do not press <TANK FILL>, a "Fill Error" will occur after approximately 4 minutes.

The developer and fixer tanks will not fill, if the integrated KODAK X-OMAT 3000 RA Processor is not pushed into the KODAK X-OMAT Multiloader 300 Plus.

The developer and fixer tanks require approximately 10 minutes to fill with solution.

Once the tanks are full, the replenisher pumps automatically turn off, and the normal warm-up period of the integrated KODAK X-OMAT 3000 RA Processor begins.

11. Press <DONE/RETURN> repeatedly until you return to the main processor menu.
12. **If using RP chemicals, add 190 ml (6.5 oz) of starter solution to the drive side of the processor's developer tank.**
13. After the replenishment pumps stop operating, check that
  - a) the levels of both the developer and the fixer solutions in the tanks are at the tank overflow limits.
  - b) there is some movement on the surface of the developer and fixer solutions to indicate that the recirculation pump is operating.

## SELECTING PROCESSOR OPTIONS OF THE INTEGRATED KODAK X-OMAT 3000 RA PROCESSOR

### A. REPLENISHMENT MODE

Automatic Replenishment Mode	Select this mode when you want the processor to automatically adjust the replenishment volumes for developer and fixer according to the film usage for the processor. See chapter "Replenishment Volume" in these Key Operator Instructions.
Flooded Replenishment Mode	Select this mode if your site has low film usage for the processor, i. e. less than 25 sheets of 35 x 43 cm (14 x 17 in.) film or equivalent area per 8-hour day. <b>Check with your KODAK SERVICE PROVIDER</b> to see whether the Flooded Replenishment Mode is right for the film usage of the processor. Replenishment will be added automatically - <ul style="list-style-type: none"> <li>• every 5 minutes, achieving a minimum replenishment of 780 ml/hr during processor operation, and</li> <li>• when the equivalent film area of 35 x 43 cm has been processed.</li> </ul>
Tank Fill Mode	Select this mode to fill empty processor tanks automatically. A warning error stating that the tanks are currently being filled, occurs as the tanks are filling. After the tanks are filled, the error is cleared and the processor will begin with normal operation.
Disable Replenishment	Select this feature to disable the replenisher pumps before carrying out any of the cleaning procedures. When the pumps are disabled, a respective error message will occur. To clear the error, simply select either Automatic or Flooded Replenishment.
Default Setting	Automatic

**Procedure:**

1. Press <GO TO SETUP> on screen 2 of the main processor menu.

PROCESSOR READY			STD	
127.4 F = DRYER TEMP		95.0 F = DEV TEMP		
DISPLAY FIX TEMP	TIME/ DATE	GOTO SETUP	DONE/ RETURN	

<input type="text"/>	<input type="text"/>	<input checked="" type="text"/>	<input type="text"/>	<input type="text"/>
----------------------	----------------------	---------------------------------	----------------------	----------------------

2. Enter the 4-digit access code.

1	2	3	4	CANCEL REQUEST
---	---	---	---	-------------------

<input checked="" type="text"/>	<input checked="" type="text"/>	<input checked="" type="text"/>	<input checked="" type="text"/>	<input type="text"/>
---------------------------------	---------------------------------	---------------------------------	---------------------------------	----------------------

3. Press <MORE>.

∧	∨	CYCLE	MORE	DONE/ RETURN
---	---	-------	------	-----------------

<input type="text"/>	<input type="text"/>	<input type="text"/>	<input checked="" type="text"/>	<input type="text"/>
----------------------	----------------------	----------------------	---------------------------------	----------------------

4. Press <OPTIONS>.

SETUP	OPTIONS			DONE/ RETURN
-------	---------	--	--	-----------------

<input type="text"/>	<input checked="" type="text"/>	<input type="text"/>	<input type="text"/>	<input type="text"/>
----------------------	---------------------------------	----------------------	----------------------	----------------------

5. Press <REPLEN MODE>.

REPLEN MODE	DAILY STARTUP	DISPLAY UNITS	MORE	DONE/ RETURN
----------------	------------------	------------------	------	-----------------

<input checked="" type="text"/>	<input type="text"/>	<input type="text"/>	<input type="text"/>	<input type="text"/>
---------------------------------	----------------------	----------------------	----------------------	----------------------

6. Select one of the operating modes  
(Automatic Replenishment requires starter in the devel. replenisher tank, and RP starter in the developer tank, if using RP chemistry.)

AUTO	FLOODED	TANK FILL	DISABLE	DONE/ RETURN
------	---------	--------------	---------	-----------------

<input type="text"/>	<input type="text"/>	<input type="text"/>	<input type="text"/>	<input type="text"/>
----------------------	----------------------	----------------------	----------------------	----------------------

7. Repeatedly press <DONE/RETURN> to store the entry and to return to the main processor menu.

## B. SELECTING THE START-UP OPTION

Selecting the Daily Start-Up option allows you to temporarily disable the Automatic Start-Up feature of Sleep Mode. This feature provides you with a convenient, easy way to leave the integrated KODAK X-OMAT 3000 RA Processor in Sleep Mode for several days without needing to re-program the daily on and off timers.

### Procedure:

1. Press <GO TO SETUP> in screen 2 of the main processor menu.

PROCESSOR READY			STD
127.4 F = DRYER TEMP		95.0 F = DEV TEMP	
DISPLAY FIX TEMP	TIME/ DATE	GOTO SETUP	DONE/ RETURN



2. Enter the 4-digit access code.

1	2	3	4	CANCEL REQUEST
---	---	---	---	-------------------



3. Press <MORE>.

∧	∨	CYCLE	MORE	DONE/ RETURN
---	---	-------	------	-----------------



4. Press <OPTIONS>.

SETUP	OPTIONS	DONE/ RETURN
-------	---------	-----------------



5. Press <DAILY STARTUP>.

REPLEN MODE	DAILY STARTUP	DISPLAY UNITS	MORE	DONE/ RETURN
----------------	------------------	------------------	------	-----------------

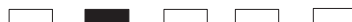

6. Press the appropriate key to select the day for which you wish to turn on or turn off the Automatic Start-Up feature.

TUESDAY DAILY STARTUP ON				
PREV DAY	NEXT DAY	ON	OFF	DONE/ RETURN



7. Select <ON> or <OFF>.

8. Repeatedly press <DONE/RETURN> until you return to the main processor menu.

## C. SELECTING THE DISPLAY UNITS FOR TEMPERATURE AND TRANSPORT SPEED

The software of the processor allows you to choose either degrees Fahrenheit (°F) or degrees Celsius (°C) for temperature units, and either English (in./min) or metric (cm/min.) units for transport speed.

**Default Setting:** English °F and in./min.

### Procedure:

1. Press <GO TO SETUP> in screen 2 of the main processor menu.

PROCESSOR READY			STD
127.4 F = DRYER TEMP		95.0 F = DEV TEMP	
DISPLAY FIX TEMP	TIME/ DATE	GOTO SETUP	DONE/ RETURN



2. Enter the 4-digit access code.

1	2	3	4	CANCEL REQUEST
---	---	---	---	-------------------



3. Press <MORE>.

∧	∨	CYCLE	MORE	DONE/ RETURN
---	---	-------	------	-----------------

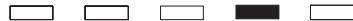

4. Press <OPTIONS>.

SETUP	OPTIONS	DONE/ RETURN
-------	---------	-----------------



5. Press <DISPLAY UNITS>.

REPLEN MODE	DAILY STARTUP	DISPLAY UNITS	MORE	DONE/ RETURN
----------------	------------------	------------------	------	-----------------



6. Press either <ENGLISH> for °F and in./min or <METRIC> for °C and cm/min

UNITS ARE ENGLISH		
ENGLISH	METRIC	DONE/ RETURN



7. Repeatedly press <DONE/RETURN> until you return to the main processor menu.

### D. SELECTING A STAND-BY MODE

The integrated KODAK X-OMAT 3000 RA Processor will enter the standby mode if no films are fed for approx. 15 seconds. There are two possibilities within the standby mode: the **interval** mode or the **continuous** mode. When the processor is in the interval mode, the transport system and wash water turn on periodically to keep the rollers wet. When the processor is in the continuous mode, the transport system will operate continuously at a reduced speed to keep the rollers wet.

In either mode, the following actions take place:

- \* the dryer blower and heater turn on as required to maintain the dryer temperature,
- \* the wash water turns on every 8 1/2 minutes to clean the rollers,
- \* the solution heaters remain on as needed to maintain the setpoint temperature of the solutions.

**Default setting:** Interval.

**Procedure:**

1. Press <GO TO SETUP> in screen 2 of the main processor menu.

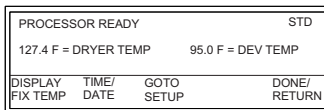

2. Enter the 4-digit access code.



3. Press <MORE>.

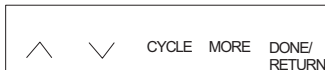

4. Press <OPTIONS>.



5. Press <MORE>.



6. Press <STANDBY MODE>.





7. Press <INTER>  
or <CONT>.



8. Repeatedly press  
<DONE/RETURN>, until  
you return to the main  
processor menu.

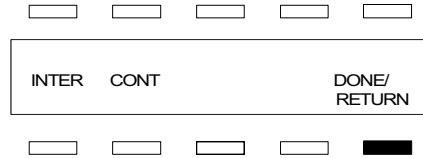

## E. SELECTING SLEEP MODE OPTIONS

You can choose how the Sleep Mode feature operates by selecting or not selecting the Roller Jog and the Cool Down options and by setting the values of the On and Off Timers for the Auto Start-Up option.

The selection of the **Roller Jog feature** reduces chemical buildup on the rack and crossover rollers. When the Roller Jog feature is selected, the transport motor and wash water activate periodically supplying the crossover troughs with water. Therefore, it is recommended that you select the Roller Jog option when operating the processor in Sleep Mode.

The selection of the **Cool Down feature** prevents the condensation of processing solutions. When you select the Cool Down feature, the dryer blower operates for 3 hours to exhaust the moist, warm air from the processor. Therefore, the Cool Down feature, like the Roller Jog feature, reduces the buildup of chemicals on the rack and crossover rollers. It is recommended that you also select the Cool Down option when operating the processor in Sleep Mode.

**Default Settings:** Roller Jog - Off Cool Down - Off

### Procedure for Turning On and Off the Roller Jog Option:

1. Press <GO TO SETUP> in screen 2 of the main processor menu.

PROCESSOR READY		STD	
127.4 F = DRYER TEMP		95.0 F = DEV TEMP	
DISPLAY FIX TEMP	TIME/ DATE	GOTO SETUP	DONE/ RETURN
<input type="checkbox"/>	<input type="checkbox"/>	<input checked="" type="checkbox"/>	<input type="checkbox"/>

2. Enter the 4-digit access code.

1	2	3	4	CANCEL REQUEST
<input checked="" type="checkbox"/>	<input checked="" type="checkbox"/>	<input checked="" type="checkbox"/>	<input checked="" type="checkbox"/>	<input type="checkbox"/>

3. Press <MORE>.

∧	∨	CYCLE	MORE	DONE/ RETURN
<input type="checkbox"/>	<input type="checkbox"/>	<input type="checkbox"/>	<input checked="" type="checkbox"/>	<input type="checkbox"/>

4. Press <OPTIONS>.

SETUP	OPTIONS	DONE/ RETURN	
<input type="checkbox"/>	<input checked="" type="checkbox"/>	<input type="checkbox"/>	<input type="checkbox"/>

5. Press <MORE>.

REPLEN MODE	DAILY STARTUP	DISPLAY UNITS	MORE	DONE/ RETURN
<input type="checkbox"/>	<input type="checkbox"/>	<input type="checkbox"/>	<input checked="" type="checkbox"/>	<input type="checkbox"/>

6. Press <ROLLER JOG>.

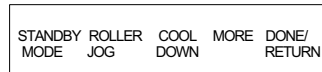

7. Press either <ON> to enable the Roller Jog option, or <OFF> to disable the Roller Jog option.



8. Press <DONE/RETURN> repeatedly until you return to the main processor menu.

### Procedure for Turning On or Off the Cool Down Option:

1. Press <GO TO SETUP> in screen 2 of the main processor menu.

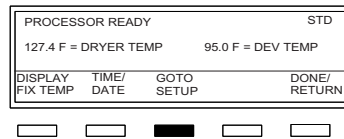

2. Enter the 4-digit access code.

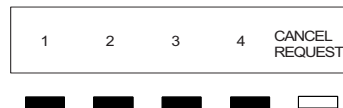

3. Press <MORE>.



4. Press <OPTIONS>.



5. Press <MORE>.

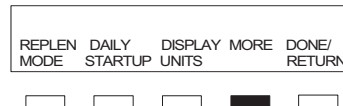

6. Press <COOL DOWN>.

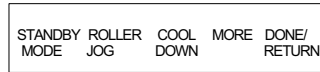

7. Press either <ON> to enable the Cool Down option, or <OFF> to disable the Cool Down option.

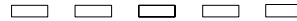
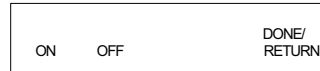

8. Press <DONE/RETURN> repeatedly until you return to the main processor menu.

## SELECTING PROCESSOR CYCLE K/RA

If chemistry has to be changed from RP to RA, or vice versa, carry out the following steps:

1. Press <GO TO SETUP> in screen 2 of the main processor menu.

PROCESSOR READY		STD	
127.4 F = DRYER TEMP		95.0 F = DEV TEMP	
DISPLAY FIX TEMP	TIME/ DATE	GOTO SETUP	DONE/ RETURN



2. Enter the 4-digit access code.

1	2	3	4	CANCEL REQUEST
---	---	---	---	-------------------



3. Press <CYCLE>.

∧	∨	CYCLE	MORE	DONE/ RETURN
---	---	-------	------	-----------------



4. Select the required cycle.

RAPID CYCLE	STD CYCLE	EXTD CYCLE	K/RA CYCLE	DONE/ RETURN
----------------	--------------	---------------	---------------	-----------------



5. Repeatedly press the < DONE/RETURN > key to store the entry and to return to the main processor menu (also refer to chapter "CYCLE INFORMATION FOR THE PROCESSOR" in this Operator Guide).

## SELECTING THE K/RA CYCLE SETPOINT DEFAULTS

The integrated KODAK X-OMAT 3000 RA Processor has 3 possible default cycle options:

- \* US (default setting)
- \* Europe
- \* Japan

### Procedure:

1. Press <GO TO SETUP> in screen 2 of the main processor menu.

PROCESSOR READY		STD	
127.4 F = DRYER TEMP		95.0 F = DEV TEMP	
DISPLAY FIX TEMP	TIME/ DATE	GOTO SETUP	DONE/ RETURN



2. Enter the 4-digit access code.

1	2	3	4	CANCEL REQUEST
---	---	---	---	-------------------



3. Press <MORE>.

∧	∨	CYCLE	MORE	DONE/ RETURN
---	---	-------	------	-----------------



4. Press <OPTIONS>.

SETUP	OPTIONS			DONE/ RETURN
-------	---------	--	--	-----------------



5. Press <MORE>.

REPLEN MODE	DAILY STARTUP	DISPLAY UNITS	MORE	DONE/ RETURN
----------------	------------------	------------------	------	-----------------



6. Press <MORE>.

STANDBY MODE	ROLLER JOG	COOL DOWN	MORE	DONE/ RETURN
-----------------	---------------	--------------	------	-----------------



7. Press <CYCLE DEFAULT>.

CYCLE DEFAULT				DONE/ RETURN
------------------	--	--	--	-----------------

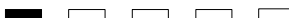

8. Press the appropriate key. Then repeatedly press <DONE/RETURN> to store the entry and to return to the main processor menu.

U.S.	EUROPE	JAPAN			DONE/ RETURN
------	--------	-------	--	--	-----------------

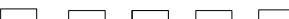

## SETTING UP THE INTEGRATED KODAK X-OMAT 3000 RA PROCESSOR

### A. DEVELOPER AND FIXER SETPOINT TEMPERATURES

Developer and Fixer temperature setpoints can be modified and stored for future use. Setpoints that were preset at the factory always can be restored by pressing the <DEFAULT SETTING> key in step 9.

#### Procedure:

1. Press <GO TO SETUP> in screen 2 of the main processor menu.

PROCESSOR READY		STD	
127.4 F = DRYER TEMP		95.0 F = DEV TEMP	
DISPLAY FIX TEMP	TIME/ DATE	GOTO SETUP	DONE/ RETURN



2. Enter the 4-digit access code.

1	2	3	4	CANCEL REQUEST
---	---	---	---	-------------------



3. Press <MORE>.

∧	∨	CYCLE	MORE	DONE/ RETURN
---	---	-------	------	-----------------



4. Press <SETUP>.

SETUP	OPTIONS			DONE/ RETURN
-------	---------	--	--	-----------------

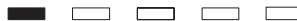

5. Press <PROCESS>.

PROCESS CLOCK	AUTO STARTUP	PUMP CALIB	DONE/ RETURN
---------------	-----------------	---------------	-----------------



6. Press the key for the current film processing cycle.

RAPID CYCLE	STD CYCLE	EXTD CYCLE	K/RA CYCLE	DONE/ RETURN
----------------	--------------	---------------	---------------	-----------------

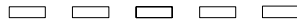

7. Press <TEMP>.

TEMP	REPLEN VOLUME	SPEED	DONE RETURN	
------	------------------	-------	----------------	--



8. Press either <DEV TEMP> to change the developer setpoint temperature, or <FIX TEMP> to change the fixer setpoint temperature.



9. To change the temperature set-point press the
- " Δ " key to increase it
  - " ∇ " key to decrease it
  - <DEFAULT SETTING> key to return to the factory set-point
  - <CANCEL REQUEST> key to return to the last value set.
10. Carry out steps 8 and 9 for the other solution.
11. Repeatedly press <DONE/RETURN> to store the entry, and to return to the main processor menu.

**NOTE:**

**The temperature set-point for the fixer is a minimum only,  
the temperature may rise above this set-point.**



## B. REPLENISHMENT VOLUME

Changes of the replenishment volume will be stored for the cycle until new changes are made. Replenishment volume is dependent on the replenishment mode: Automatic or Flooded.

In the **Automatic Replenishment** mode, replenishment solutions are added when an area of film equivalent to approximately 1500 cm<sup>2</sup> (240 in.<sup>2</sup>) has been processed, for example, one 35 x 43cm (14 x 17 in.) sheet of film.

As film usage for the integrated KODAK X-OMAT 3000 RA Processor lessens, the volumes of developer and fixer necessary for correct replenishment increase.

Film Usage	Films/ 1/2 hour	(Auto) Replenishment Volume	
		Developer (ml/sheet)	Fixer (ml/sheet)
Low	1 - 2	92	113
Medium	3 - 4	73	95
High	5 (or more)	55*	80*

\*default value

The key operator enters the volume for developer ( $V_{dev}$ ) and fixer ( $V_{fix}$ ) replenishment on the key-pad for high film usage.

The microprocessor automatically calculates the replenishment volumes for low and medium film usage.

Film Usage	New (Auto) Replenishment Volume	
	Developer (ml/sheet)	Fixer (ml/sheet)
Low	$1,67 \times (V_{dev})$	$1,41 \times (V_{fix})$
Medium	$1,33 \times (V_{dev})$	$1,18 \times (V_{fix})$
High	$(V_{dev})$	$(V_{fix})$

In the **Flooded Replenishment** mode, default developer and fixer replenishment volumes are

- 65 ml every 5 minutes and
- 65 ml for each 1500cm<sup>2</sup> (240in.<sup>2</sup>) of film.

**IMPORTANT:**

Before changing the replenishment rates, carry out a replenishment calibration.

If it is necessary to change the replenishment volumes from the factory default settings, follow the procedure outlined below.

1. Press <GO TO SETUP> in screen 2 of the main processor menu.

PROCESSOR READY		STD	
127.4 F = DRYER TEMP		95.0 F = DEV TEMP	
DISPLAY	TIME/	GOTO	DONE/
FIX TEMP	DATE	SETUP	RETURN



2. Enter the 4-digit access code.

1	2	3	4	CANCEL
				REQUEST



3. Press <MORE>.

∧	∨	CYCLE	MORE	DONE/
				RETURN



4. Press <SETUP>.

SETUP	OPTIONS			DONE/
				RETURN

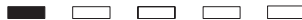

5. Press <PROCESS>.

PROCESS CLOCK	AUTO	PUMP	DONE/
	STARTUP	CALIB	RETURN



6. Select the **current** operating cycle.

RAPID	STD	EXTD	K/RA	DONE/
CYCLE	CYCLE	CYCLE	CYCLE	RETURN

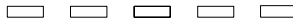

7. Press <REPLEN VOLUME>.

TEMP	REPLEN	SPEED	DONE/
	VOLUME		RETURN

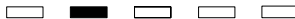

8. Press < DEV REP VOLUME> to change the developer replenishment volume, or < FIX REP VOLUME> to change the fixer replenishment volume.

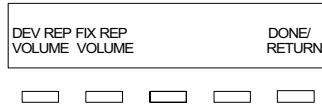

9. To change the replenishment volume press -
- " Δ " key to increase the replenishment volume
  - " ∇ " key to decrease the replenishment volume
  - <DEFAULT SETTING> key to return to the factory values
  - <CANCEL REQUEST> key to return to the last value set.

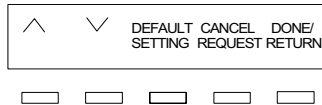

10. Repeatedly press the <DONE/RETURN> key to store the entry, and to return to the main processor menu.
11. Carry out steps 8 through 10 for the other solution.

### Verifying the Replenishment Rates:

- Separate the integrated KODAK X-OMAT 3000 RA Processor from the unit as described on page 1-42, and remove the wet section cover.
- Insert the end of the developer (or fixer) replenishment hose into a graduated cylinder (see illustration on page 2-51).
- Hold the graduated cylinder over the wash section of the processor so that spills will not contaminate the processing solutions.
- Press and hold for 5 seconds the replenishment calibration switch located on the side wall of the processor tank (see illustration on page 2-51).
- Allow the replenishment pumps to turn on and deliver the preset volume of replenishment solution.
- Compare the volume of replenishment solution delivered into the graduated cylinder to the replenishment volume you set in the previous procedure.
- Re-insert the wet section cover and **carefully** slide in the integrated KODAK X-OMAT 3000 RA Processor as described on page 1-45.  
If the 2 volumes are not within 10% of each other, do the "Calibrating the Replenishment System" procedure described on page 2-49.

## C. PROCESSOR SPEED

The transport speed can be changed for each cycle. The new speed value will be stored for that cycle.

To change the transport speed, carry out the following steps:

1. Press <GO TO SETUP> in screen 2 of the main processor menu.

PROCESSOR READY		STD	
127.4 F = DRYER TEMP		95.0 F = DEV TEMP	
DISPLAY FIX TEMP	TIME/ DATE	GOTO SETUP	DONE/ RETURN
<input type="checkbox"/>	<input type="checkbox"/>	<input checked="" type="checkbox"/>	<input type="checkbox"/>

2. Enter the 4-digit access code.

1	2	3	4	CANCEL REQUEST
<input checked="" type="checkbox"/>	<input checked="" type="checkbox"/>	<input checked="" type="checkbox"/>	<input checked="" type="checkbox"/>	<input type="checkbox"/>

3. Press <MORE>.

∧	∨	CYCLE	MORE	DONE/ RETURN
<input type="checkbox"/>	<input type="checkbox"/>	<input type="checkbox"/>	<input checked="" type="checkbox"/>	<input type="checkbox"/>

4. Press <SETUP>.

SETUP	OPTIONS	DONE/ RETURN	
<input checked="" type="checkbox"/>	<input type="checkbox"/>	<input type="checkbox"/>	<input type="checkbox"/>

5. Press <PROCESS>.

PROCESS CLOCK	AUTO STARTUP	PUMP CALIB	DONE/ RETURN
<input checked="" type="checkbox"/>	<input type="checkbox"/>	<input type="checkbox"/>	<input type="checkbox"/>

6. Select the **current operating cycle**.

RAPID CYCLE	STD CYCLE	EXTD CYCLE	K/RA CYCLE	DONE/ RETURN
<input type="checkbox"/>	<input type="checkbox"/>	<input type="checkbox"/>	<input type="checkbox"/>	<input type="checkbox"/>

7. Press <SPEED>.

TEMP	REPLEN VOLUME	SPEED	DONE/ RETURN
<input type="checkbox"/>	<input type="checkbox"/>	<input checked="" type="checkbox"/>	<input type="checkbox"/>

8. To change the transport speed press -
- a) "Δ" key to increase the transport speed.
  - b) "∇" key to decrease the transport speed.
  - c) <DEFAULT SETTING> key to return to the factory set-point speed.
  - d) <CANCEL REQUEST> key to return to the last value set.

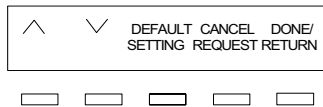

9. Repeatedly press the <DONE/RETURN> key to store the entry, and to return to the main processor menu.

## D. TIME AND DATE

By setting the clock of the integrated KODAK X-OMAT 3000 RA Processor, you can take advantage of several of the features that the processor offers:

- Auto Start-Up and Shutdown
- Time and Date Stamping of Error Messages

When setting the time and date, you may choose from several different formats:

Time Formats:

- 12 Hour
- 24 Hour

Date Formats (where M=Month, D=Day, and Y=Year):

- M-D-Y
- D-M-Y
- Y-M-D

### Procedure:

1. Press <GO TO SETUP> in screen 2 of the main processor menu.

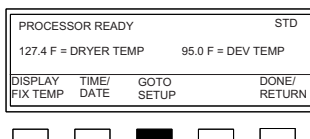

2. Enter the 4-digit access code.



3. Press <MORE>.

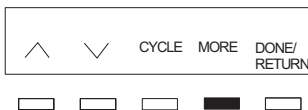

4. Press <SETUP>.

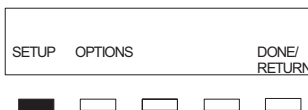

5. Press <CLOCK>.

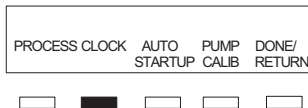

6. Press <TIME FORMAT>.

SET TIME	SET DATE	TIME FORMAT	DATE FORMAT	DONE/ RETURN
<input type="checkbox"/>	<input type="checkbox"/>	<input checked="" type="checkbox"/>	<input type="checkbox"/>	<input type="checkbox"/>

7. Select the <FORMAT> key of your choice.

12 HOUR FORMAT	24 HOUR FORMAT		DONE/ RETURN
<input type="checkbox"/>	<input type="checkbox"/>	<input type="checkbox"/>	<input type="checkbox"/>

8. Press <DONE/RETURN> **once** to return to the format options.

9. Press <DATE FORMAT>.

SET TIME	SET DATE	TIME FORMAT	DATE FORMAT	DONE/ RETURN
<input type="checkbox"/>	<input type="checkbox"/>	<input type="checkbox"/>	<input checked="" type="checkbox"/>	<input type="checkbox"/>

10. Select the <FORMAT> key of your choice.

M-D-Y FORMAT	D-M-Y FORMAT	Y-M-D FORMAT	DONE/ RETURN
<input type="checkbox"/>	<input type="checkbox"/>	<input type="checkbox"/>	<input type="checkbox"/>

11. Press <DONE/RETURN> **once** to return to the set time and set date options.

12. Press <SET TIME>.

SET TIME	SET DATE	TIME FORMAT	DATE FORMAT	DONE RETURN
<input checked="" type="checkbox"/>	<input type="checkbox"/>	<input type="checkbox"/>	<input type="checkbox"/>	<input type="checkbox"/>

13. Use the up and down arrow keys to set the time in hours and minutes.

^ HOUR	v HOUR	^ MINUTE	v MINUTE	DONE/ RETURN
<input type="checkbox"/>	<input type="checkbox"/>	<input type="checkbox"/>	<input type="checkbox"/>	<input type="checkbox"/>

14. Press <DONE/RETURN> **once** to return to the set date option.

15. Press <SET DATE>.

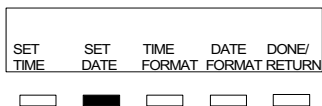

16. Press <SET DATE>.



17. Use the up and down arrow keys to set the date.

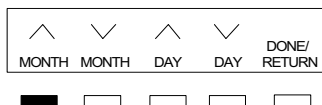

18. Press <DONE/RETURN> **once** to return to the set year option.

19. Press <SET YEAR>.

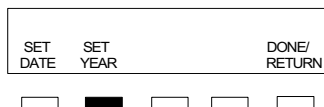

20. Use the up and down arrow keys to set the year.

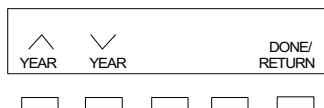

21. Repeatedly press <DONE/RETURN> until you return to the main processor menu.



## E. AUTOMATIC ON AND OFF TIMERS

The processor software provides you programmable timers so that you may program 2 distinct on and off times for the processor each day. The Automatic Timers allow you to specify a start time for the processor to energize automatically so that the processing solutions and the dryer will have reached their setpoint temperatures before you arrive at the work site. The processor can store up to 2 „start times“ and 2 „off times“ for each day of the week to coincide with changing shifts or with weekend schedules.

### Example of use:

For instance, if you would like the processor to be warmed up and ready to accept films by the time you arrive at work in the morning, you may set Timer1 to turn on the processor at 6:00 a.m. If you operate during 2 distinct shifts and there is a large lapse in time between the 2 shifts, you might want to set Timer1 to turn off the processor at the end of the first shift. You might then want to set Timer2 to turn on the processor again an hour before the second shift starts for the afternoon. And finally, you might want to set Timer2 to turn off the processor for the night at the end of the second shift.

### NOTE:

**Do not set the On and Off Timers within 15 minutes of each other. To ensure the correct operation of the processor, the processor must remain on for at least 15 minutes before the Automatic Off Timer turns it off. Likewise, the processor must remain off for at least 15 minutes before the Automatic On Timer turns it on.**

### Procedure for Setting Timer1 Initially:

Before proceeding with the steps described on the next page, be sure that you have completed the procedure for setting the time and date starting on page 2-39.

1. Press <GO TO SETUP> in screen 2 of the main processor menu.

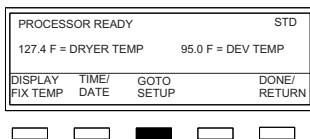

2. Enter the 4-digit access code.

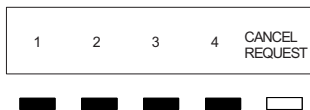

3. Press <MORE>.

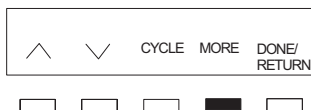

4. Press <SETUP>.

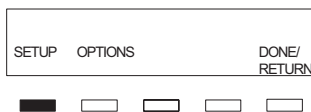

5. Press <AUTO STARTUP>.

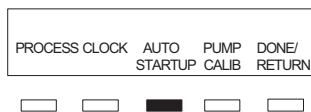

6. Press <ON>.

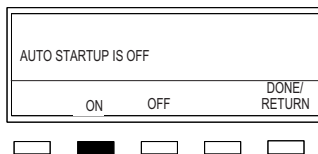

7. Press <SET TIMERS>.

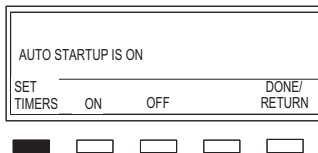

### - Setting the On Time:

8. Press <TIMER1 CONTROL>.

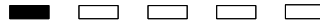
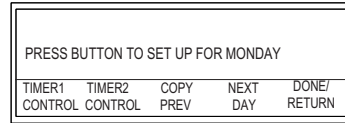

9. Press <ON TIME>.

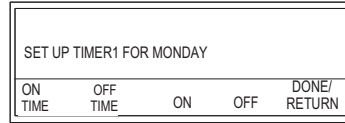

10. Use the up and down arrow keys to select the hour and minute when you want the integrated KODAK X-OMAT 3000 RA Processor to turn on.

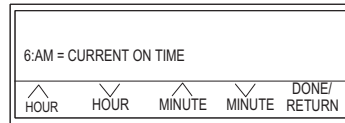

11. Press the <DONE/RETURN> to return to the menu options shown beside.

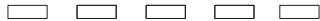
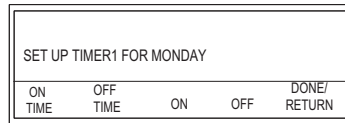

### - Setting the Off Time:

#### NOTE:

Any time the screen shown below appears on the Display Panel, you can press <OFF> to erase the last programmed on and off times for Timer1 and Timer2.

12. Press <OFF TIME>.

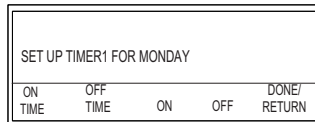

13. Use the up and down arrow keys to select the hour and minute when you want the integrated KODAK X-OMAT 3000 RA Processor to turn off.

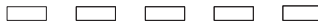
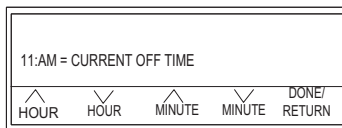

14. Press <DONE/RETURN> repeatedly until you return to the menu shown beside.

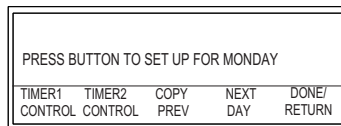

### Procedure for Setting Timer2 Initially:

1. Press <TIMER2 CONTROL>.

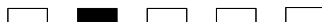
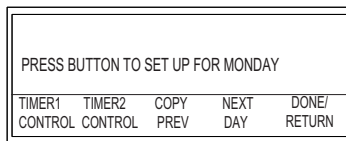

2. Repeat steps 9 through 14 starting on page 2-45 to set the on and off times for Timer2. Then set the on and off times for the remaining days of the week by completing the steps of the following description.

## Procedure for Setting the On and Off Timers for the Remaining Days of the Week

If the hours that you would like to operate the integrated KODAK X-OMAT 3000 RA Processor on the other days of the week are the same hours as those you set for Monday, follow steps 1 through 3 below. If you do not want to repeat Monday's on and off times for the other days of the week, follow steps 4 through 13.

### - Copying On and Off Timer Settings

1. Press <NEXT DAY>.

PRESS BUTTON TO SET UP FOR MONDAY				
TIMER1	TIMER2	COPY	NEXT	DONE/
CONTROL	CONTROL	PREV	DAY	RETURN

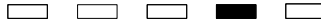

2. Press <COPY PREV>.  
After pressing this key, you will hear a beep. To ensure that Monday's on and off times will be repeated for the next day, carry out the steps below.

PRESS BUTTON TO SET UP FOR TUESDAY				
TIMER1	TIMER2	COPY	NEXT	DONE/
CONTROL	CONTROL	PREV	DAY	RETURN



3. Repeat the entire process to set the Automatic Timers for the remaining days of the week.

### - Setting Different On and Off Times for the Remaining Days

If you want to select different on and off times for Timer1 and Timer2 than those you set for Monday, carry out the steps below.

4. Press <NEXT DAY> to advance the display to show Tuesday.

PRESS BUTTON TO SET UP FOR MONDAY				
TIMER1	TIMER2	COPY	NEXT	DONE/
CONTROL	CONTROL	PREV	DAY	RETURN



5. Press <TIMER1 CONTROL>.

PRESS BUTTON TO SET UP FOR TUESDAY				
TIMER1	TIMER2	COPY	NEXT	DONE/
CONTROL	CONTROL	PREV	DAY	RETURN



6. Press <ON> to enable Timer1.

SET UP TIMER1 FOR MONDAY				
ON TIME	OFF TIME	ON	OFF	DONE/ RETURN



7. Press <ON TIME>.

SET UP TIMER1 FOR TUESDAY				
ON TIME	OFF TIME	ON	OFF	DONE/ RETURN



8. Use the up and down arrow keys to select the hour and minute when you want the processor to turn on.

2:00 PM = CURRENT ON TIME				
^ HOUR	v HOUR	^ MINUTE	v MINUTE	DONE/ RETURN



9. Press <DONE/RETURN> until you return to the menu options displayed beside. Then press <OFF TIME>.

SET UP TIMER1 FOR TUESDAY				
ON TIME	OFF TIME	ON	OFF	DONE/ RETURN



10. Use the up and down arrow keys to select the hour and minute when you want the processor to turn off.

11:00 PM = CURRENT OFF TIME				
^ HOUR	v HOUR	^ MINUTE	v MINUTE	DONE/ RETURN



11. Press <DONE/RETURN> twice to return to the menu options displayed beside. Then press <TIMER2 CONTROL>.

PRESS BUTTON TO SET UP FOR TUESDAY				
TIMER1 CONTROL	TIMER2 CONTROL	COPY PREV	NEXT DAY	DONE/ RETURN



12. Repeat Steps 7 through 11 to set the on and off time settings for Timer2.
13. Repeat the entire process to set the Automatic Timers for the remaining days of the week.

## F. CALIBRATING THE REPLENISHMENT SYSTEM

**Calibrate the replenishment system every 3 months, or whenever you add new chemicals to the processor.**

The key operator calibrates the replenishment system for all process cycles in one operation that determines the actual rate of solution flow through the replenisher pumps. The operator will measure the volume of solution pumped during a set period of time, then use the display panel to enter the measurement into the microprocessor. The microprocessor computes the rate of solution flow through the pump, then adjusts the period of time that the pump must operate to match the replenishment volume set by the operator.

### NOTE

The volume actually measured during this procedure is not the volume delivered for a 35 x 43 cm sheet of film.

1. Press <GO TO SETUP> in screen 2 of the main processor menu.

PROCESSOR READY		STD	
127.4 F = DRYER TEMP		95.0 F = DEV TEMP	
DISPLAY FIX TEMP	TIME/ DATE	GOTO SETUP	DONE/ RETURN



2. Enter the 4-digit access code.

1	2	3	4	CANCEL REQUEST
---	---	---	---	-------------------



3. Press <MORE>.

∧	∨	CYCLE	MORE	DONE/ RETURN
---	---	-------	------	-----------------



4. Press <SETUP>.

SETUP	OPTIONS	DONE/ RETURN
-------	---------	-----------------



5. Press <PUMP CALIB>.

PROCESS CLOCK	AUTO STARTUP	PUMP CALIB	DONE/ RETURN
---------------	-----------------	---------------	-----------------



**Procedure:**

- Press <DEV CAL> to calibrate the developer pump, or <FIX CAL> to calibrate the fixer pump.

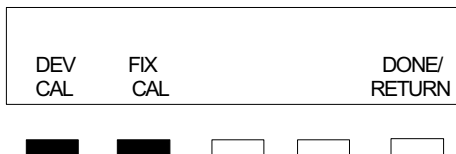
**WARNING:**

**Wear protective eye-wear when executing the following procedure.  
Replenishment solutions are pumped quickly and may splash.**

- Carefully pull out the integrated KODAK X-OMAT 3000 RA Processor.

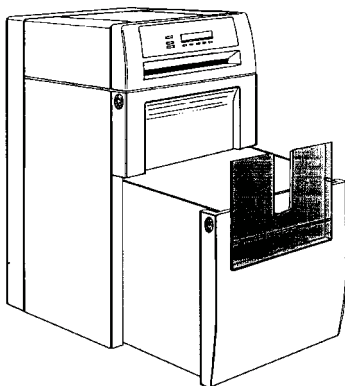

- Remove the fixer replenishment (or developer replenishment hose) and place it into the graduated cylinder (see illustration on the next page).
- Hold the graduated cylinder over the wash section of the integrated KODAK X-OMAT 3000 RA Processor so that spills will not contaminate the processing solutions.
- Press the replenishment calibration switch on the side wall of the processor tank.
- Measure and record the volume of replenishment delivered by the system.
- Dispose of the solution in the graduated cylinder.
- Carry out steps 8 through 11 at least two more times.



- 1 REPLENISHMENT CALIBRATION SWITCH
- 2 DEVELOPER REPLENISHMENT HOSE
- 3 GRADUATED CYLINDER
- 4 FIXER REPLENISHMENT HOSE
- 5 FILTER MANDREL

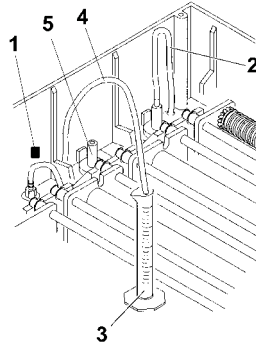

14. Determine the average volume of replenishment delivered.
15. Install the replenishment hose into the fixer (or developer) filter mandrel.
16. Carefully push the processor back into the KODAK X-OMAT Multiloader 300 Plus (see description at the end of chapter "CLEAN-UP AND PREVENTATIVE MAINTENANCE - INTEGRATED KODAK X-OMAT 3000 RA PROCESSOR").

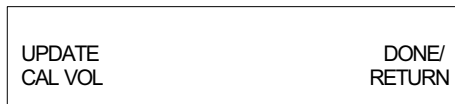

- 
17. Press the <UPDATE CAL VOL> key.
  18. Press "  $\Delta$  " or "  $\nabla$  " keys until the volume of replenishment displayed equals the average volume determined in step 14.



- 
19. Repeatedly press <DONE/RETURN> until you return to the menu shown below:
  20. Repeat steps 6 to 18 for the developer (or fixer) replenishment.
  21. Repeatedly press <DONE/RETURN> until you return to the main processor menu.

## PROBLEM SOLVING

### WARNING:

Like all other steps described in the chapter KEY OPERATOR INSTRUCTIONS the following measures may only be carried out by KEY OPERATORS who have been especially trained for that purpose by KODAK.

Transport Failure					
	Surface Artifacts				
		Abnormal Film Densities			
			Wet Films		
				Low Solution Levels	
				Overlapping of Films	
•	•	•	•		Feed only compatible films.
•					• Check that all Racks and Crossovers are seated correctly.
•	•				Check that the surfaces of all the Rollers are clean and smooth.
•	•		•		Check that all Dryer Air Tubes are installed.
	•		•		Remove any dirt from the Dryer Rollers and Air Tubes, especially the Air Tube slot and Air Diffuser. Use a Bottle Brush and rinse with water.
	•	•	•	•	Check the settings for correct replenishment. Check the <u>external</u> tubing of the replenishment system (i. e. tubing outside of the processor) for kinks.
	•				Adjust the Dryer temperature control setting to the lowest possible temperature consistent with good film drying quality.

•	•	•	•	•	Change any chemicals that were not mixed correctly, are exhausted, or are contaminated. Check that replenishment rates are correctly set. Fill the Replenishment Tanks if necessary. <b>Mix the developer replenisher in quantities not to exceed a 2-week supply. Always use a Splash Guard and Rack Drip Tray when lifting the Racks to prevent contamination. Mix chemicals as directed.</b>
•				•	Check that the Drain Valves are completely closed. Check that the Tanks are full.
•	•			•	Check that all Rollers, Gears, Sprockets, and Idlers are engaged and rotate freely.
•	•			•	Replace defective Rollers.
•	•				If incoming wash water is dirty, clean the Wash Rack, Wash Tank, and Water Reservoir thoroughly. Have the incoming water Filter changed. Be sure that the correct water Filter is used.
	•	•	•		Check incoming water temperature. Temperature must be between 4_C (40_F) and 29_C (85_F).
•					If 10 x 10 cm films fail to transport reliably, feed the sheets of films diagonally.
				•	Check that solution Level Probes are clean and free from buildup. Check that all <u>external</u> replenishment lines (i. e. those who are outside of the processor) are without kinks or air bubbles.

## PROCESSOR SET-UP AND OPTIONS

Flow Chart 1

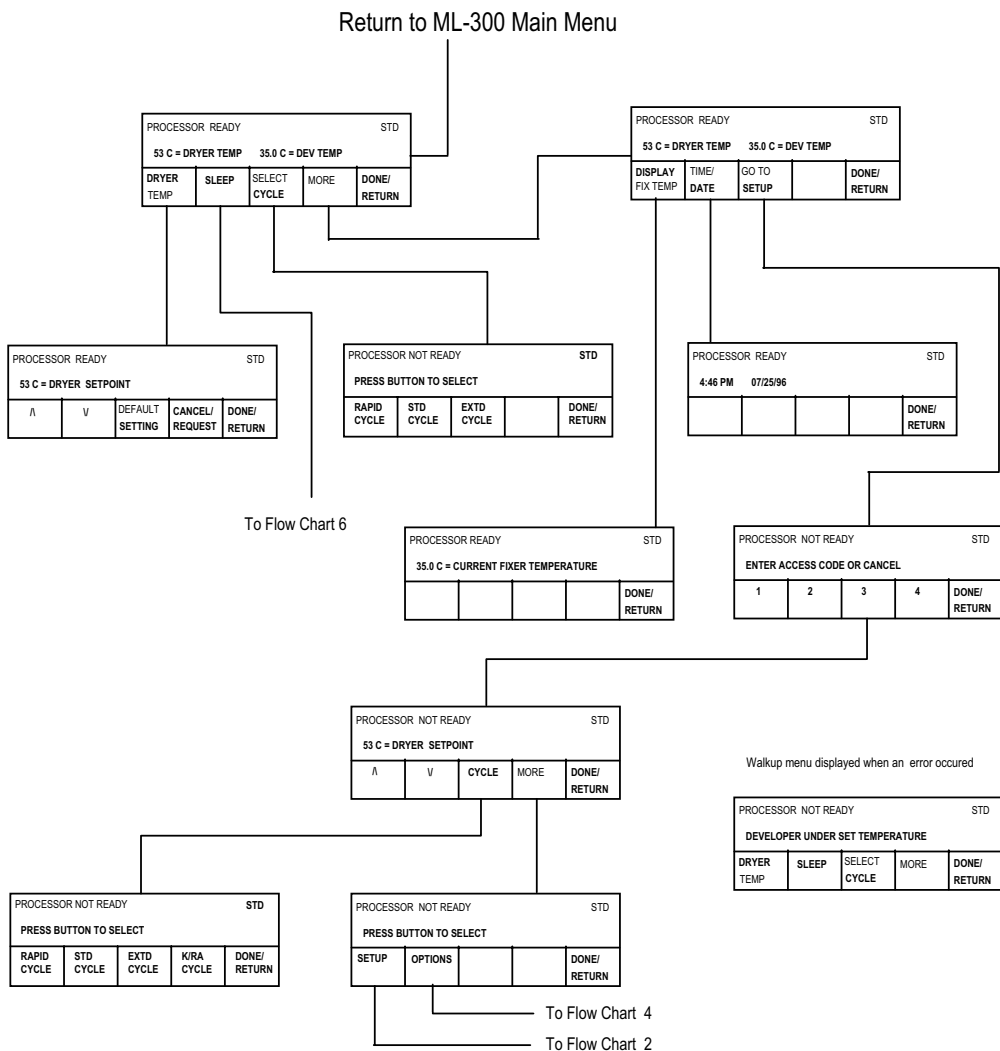

Flow Chart 2

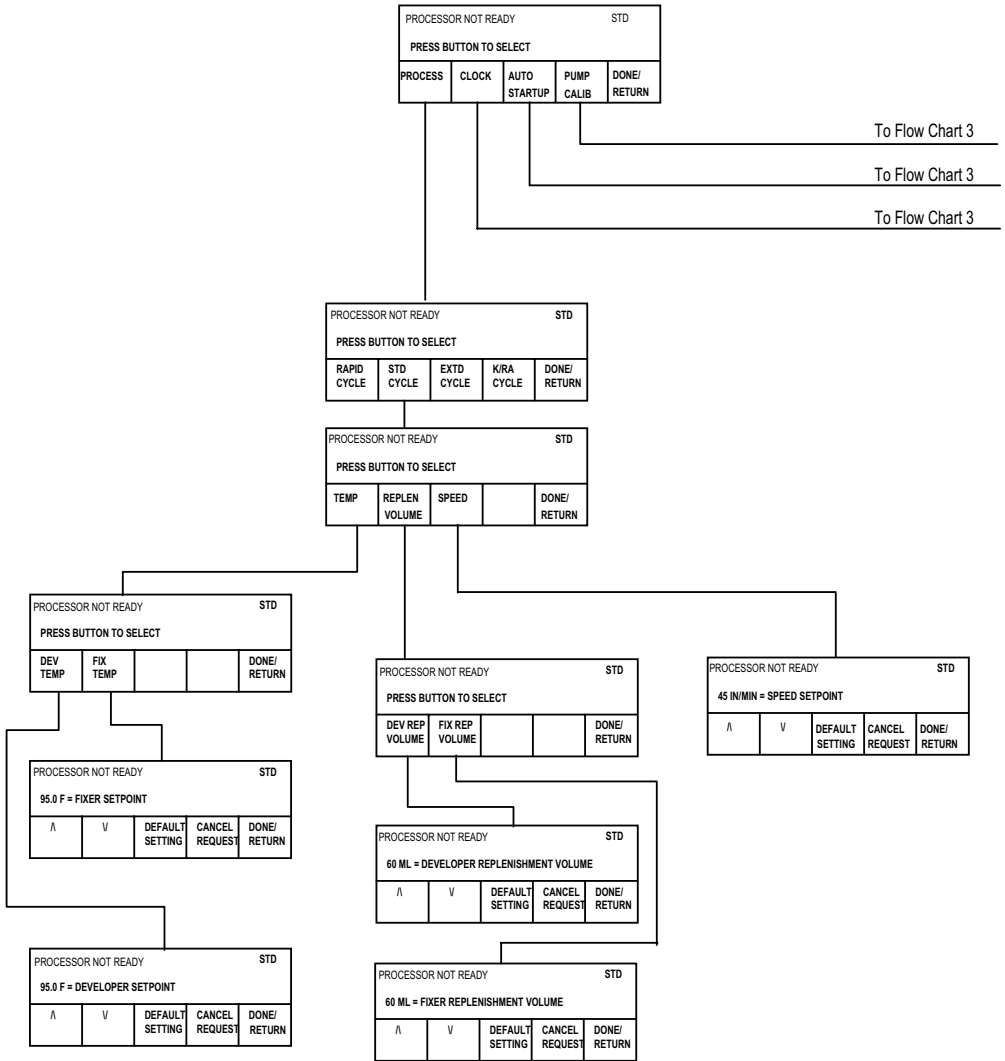

### Flow Chart 3

To Flow Chart 2

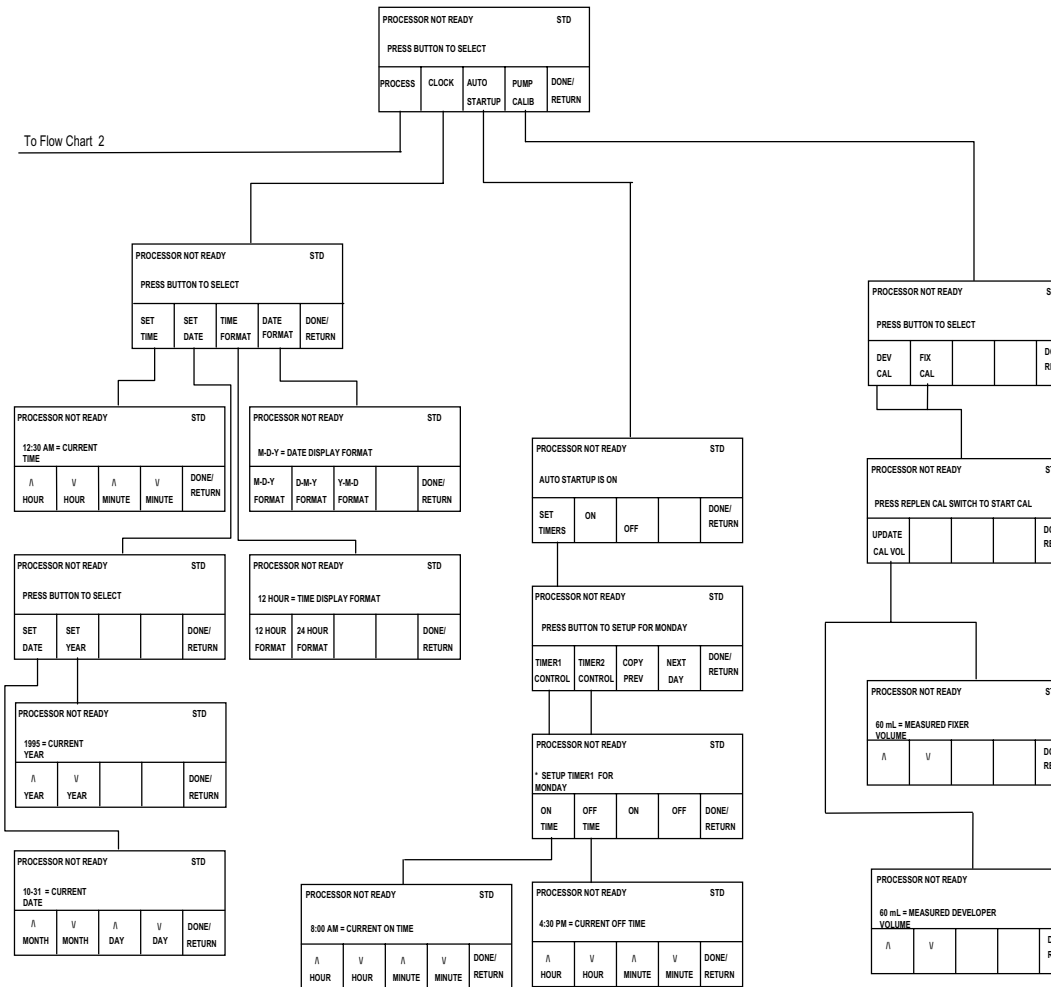

\* If timer1 or timer2 are off, the "ON TIME" and "OFF TIME" buttons will be off.

# Flow Chart 4

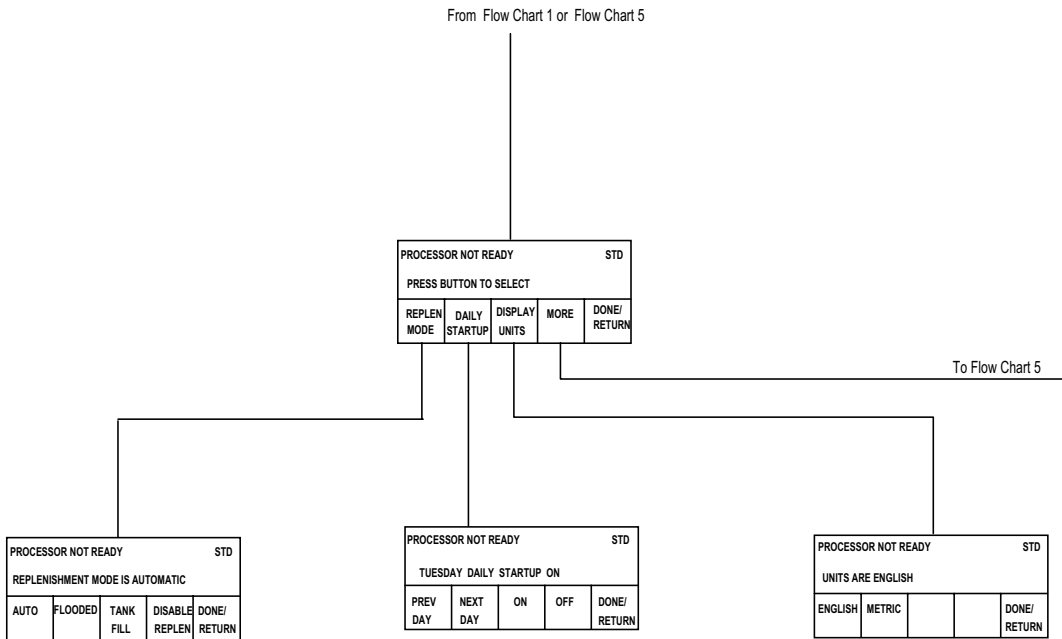

Flow Chart 5

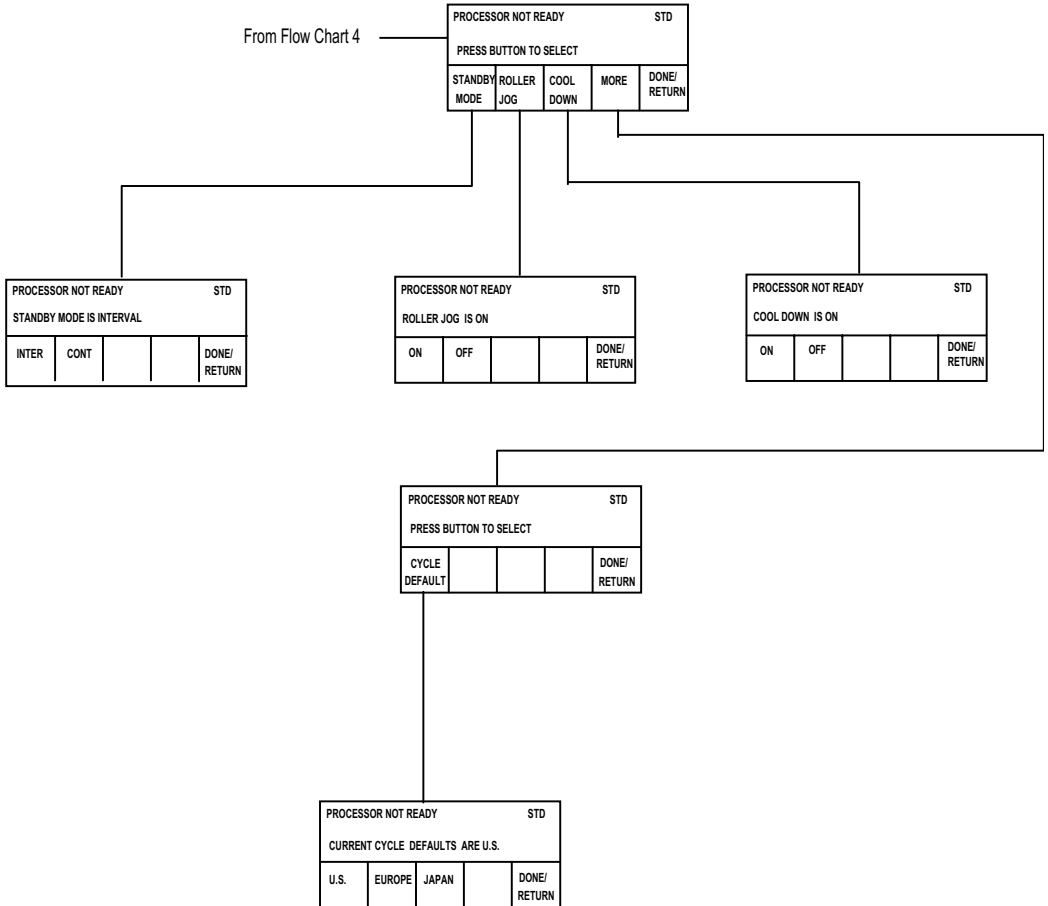



Flow Chart 6

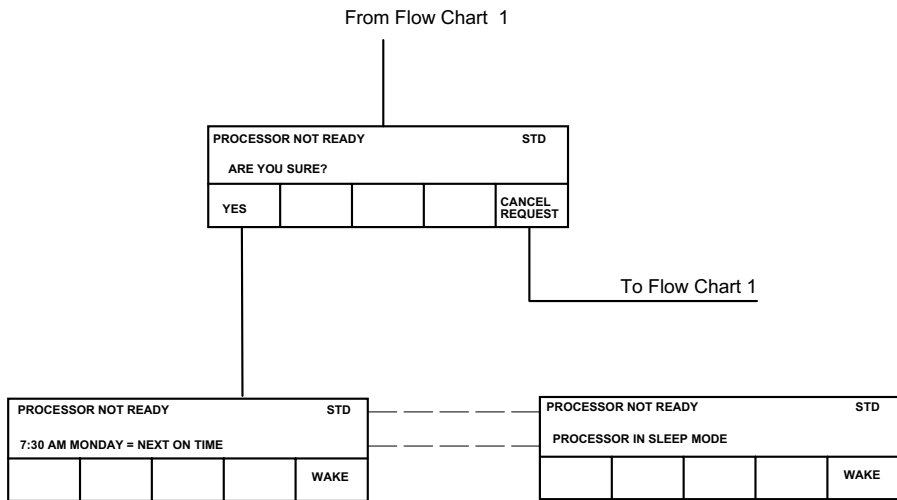

This screen will be displayed when the processor is in sleep mode and AUTO STARTUP is enabled.

This screen will be displayed when the processor is in sleep mode and AUTO STARTUP is disabled.

**Kodak AG**  
Hedelfinger Straße  
70327 Stuttgart  
Germany  
Publication No. OI 3511-5/98  
Printed in Germany

KODAK, MIN-R, X-OMAT, X-OMATIC and T-MAT are trademarks.

